

DESIGN A
(WHITE)

Use for delineation on tangents and on curves with $R > 1500'$.

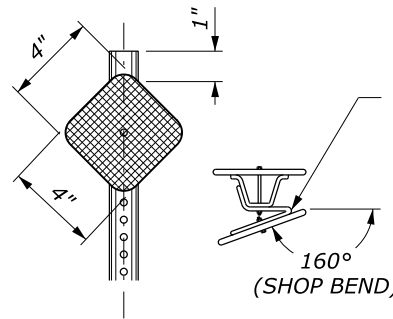

DESIGN C
(WHITE)

Use on curves with $R \leq 575'$

1" x 1/16" x 5 3/8" aluminum strap

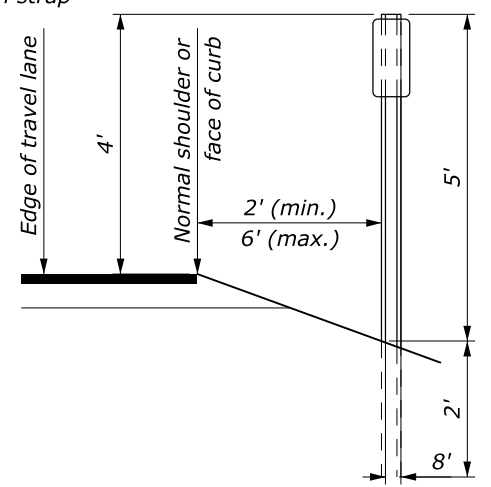
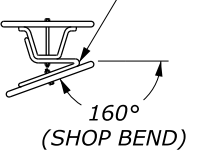

TYPICAL INSTALLATION

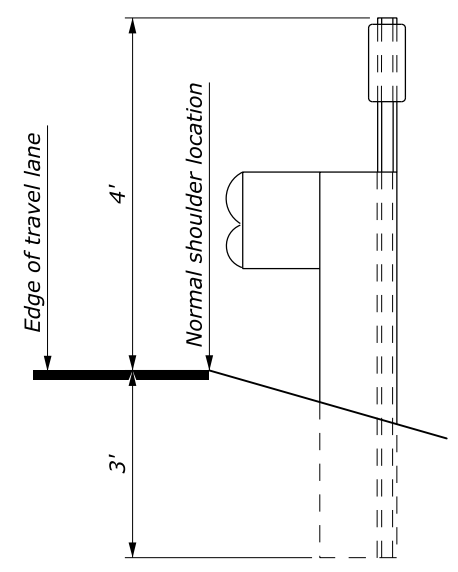

TYPICAL INSTALLATION WITH BEAM TYPE GUARD RAIL

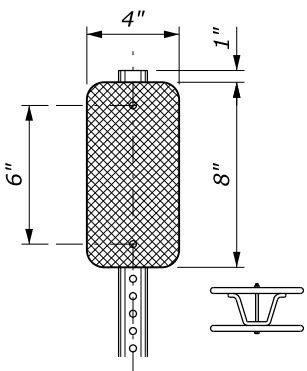

DESIGN D
(YELLOW)

Use at approaches with Stop or Yield signs.

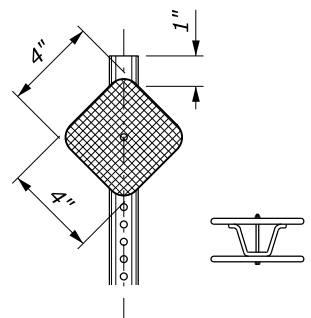

DESIGN F
(WHITE)

Use for curves with $R > 575'$ and $R \leq 1500'$.

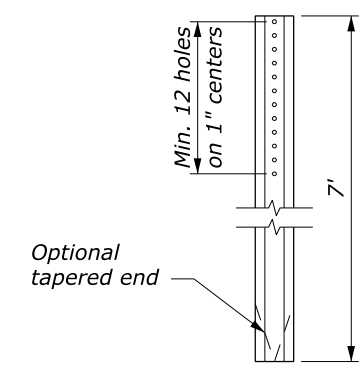

DELINEATOR POST DETAILS

Rigid Steel or Aluminum

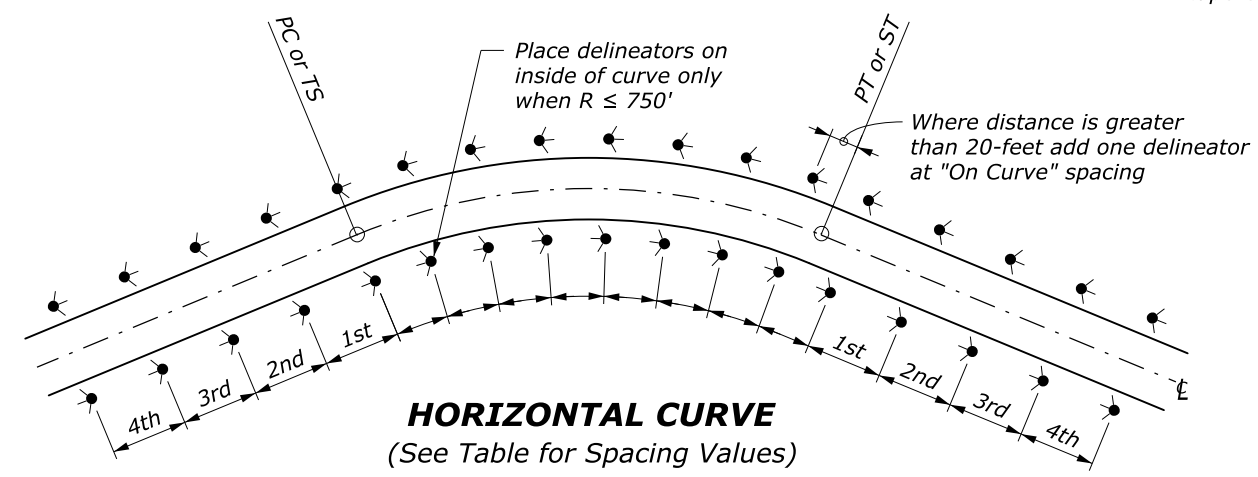
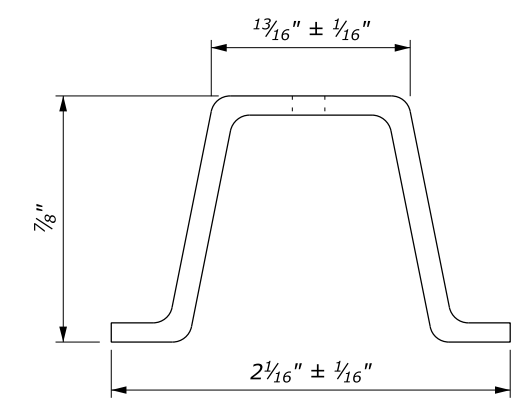

HORIZONTAL CURVE
(See Table for Spacing Values)

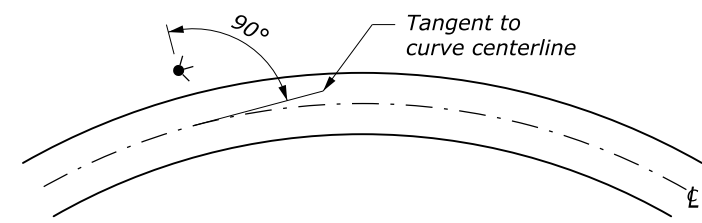

SIGN INSTALLATION ANGLE

RADIUS (ft)	SPACING ON CURVE (ft)	SPACING IN ADVANCE OF & BEYOND CURVE (ft)			
		SPACING IN ADVANCE OF & BEYOND CURVE (ft)			
		1st SPACE	2nd SPACE	3rd SPACE	4th SPACE
≥ 5700	300	400	400	400	400
3000 to < 5700	225	400	400	400	400
2000 to < 3000	160	320	400	400	400
1500 to < 2000	130	260	400	400	400
1000 to < 1500	110	220	330	400	400
700 to < 1000	90	185	275	400	400
500 to < 700	75	150	230	300	400
300 to < 500	60	125	185	300	400
< 300	45	90	140	275	400

NOTE:

- When the contract does not include the final surfacing, allow for the thickness of the final pavement structure when establishing the elevation of the traffic delineators.
- Place delineators at a constant clearance distance from the edge of pavement except where guardrail or other obstructions interfere. Align delineators with the inside edge of obstruction. Install delineators located behind beam guardrail so that the delineator post is adjacent to the trailing edge of the nearest guardrail post. (See typical installation with beam type guardrail).
- When a delineator falls within a cross road or approach, the delineator may be moved in either direction a distance not to exceed one quarter of the normal spacing. Eliminate the post if this allowance is exceeded.
- Mount delineators on metal posts with 3/16" cadmium plated bolt(s). Drill or punch a minimum of twelve 3/8" diameter holes on 1-inch centers from the top of the post. 3/8" square holes may be used with large-headed bolt or an appropriate washer. Jam threads after tightening the nut to prevent removal.
- All delineator reflectors have 3/4" corner radii.
- Manufacture posts from flanged U-channel sections of steel meeting the requirements of ASTM A 36 and weighing not less than 1.25 pounds per foot or aluminum meeting the requirements of ASTM B 221, Alloy 6061-T6, with a minimum thickness of 0.125 inches. After fabrication galvanize steel posts in accordance with ASTM A 123.
- When a route has a current ADT of 900 or greater, continuously delineate the roadway along the shoulder by means of post mounted reflectors. Spacing on tangent sections is 400 feet.

NO SCALE

U.S. DEPARTMENT OF TRANSPORTATION
FEDERAL HIGHWAY ADMINISTRATION
WESTERN FEDERAL LANDS HIGHWAY DIVISION

U.S. CUSTOMARY DETAIL

**MONTANA
DELINEATORS**

DETAIL APPROVED FOR USE 11/2006
REVISED: 1/2008

DETAIL
W633-60