

**REFLECTOR DETAILS**

DELINEATION MARKER REFLECTOR		
TYPE	COLOR OF REFLECTOR	REFLECTORIZED
A	White	Front & Rear
B	White	Front
C	Yellow	Front
D	Yellow	Front & Rear

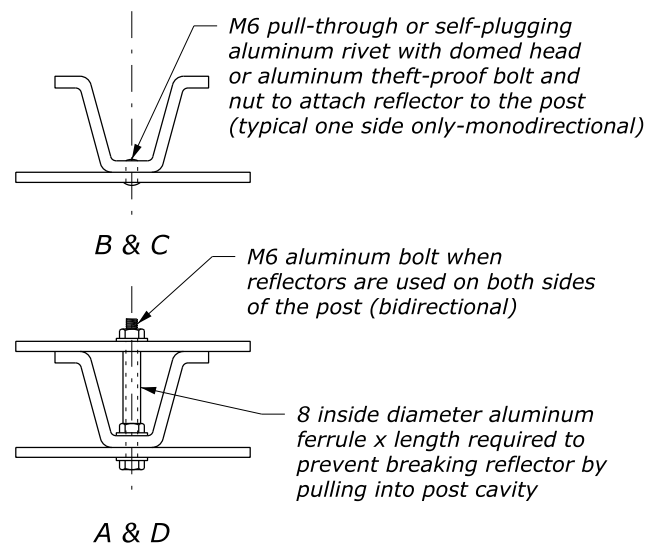

**ATTACHMENT DETAIL**

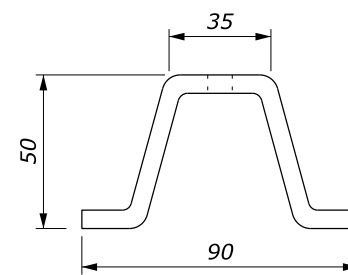

STEEL POST  
3.95 kg/m

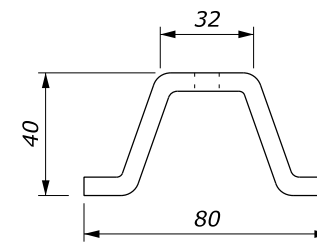

STEEL POST  
2.97 kg/m

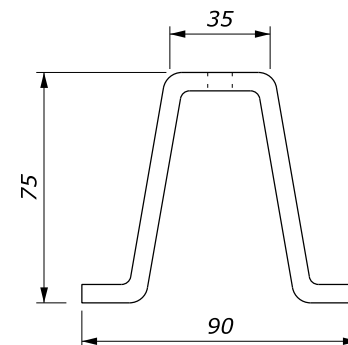

ALUMINUM POST  
2.68 kg/m

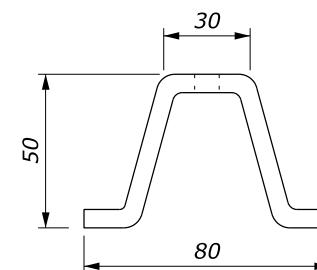

ALUMINUM POST  
1.33 kg/m

**HEAVY CHANNEL POSTS**

**LIGHT CHANNEL POSTS**

**NOTE:**

1. Vary the post spacing up to 1/8 of the spacing shown to clear driveways, cross roads, intersections or ramps. Eliminate the post in cases where the variation is exceeded.
2. Dimensions of channel posts shown indicate general design only and may vary slightly among manufacturers.
3. When specified rectangular 75 x 150 mm reflectors may be used in lieu of double disk reflector.
4. Offset delineators 600 mm unless otherwise shown.
5. See plans for delineator reflector colors.
6. Use tangent spacing of 150 m ± (160 m maximum).
7. When the contract does not include the final pavement, allow for the ultimate base and pavement thickness when establishing the traffic delineator elevation.
8. On two way roads, stagger markers on opposite sides of the road.
9. Furnish hardware in the metric sizes shown. Equivalent US Customary sizes may be used when metric sizes are unavailable.
10. Dimensions without units are millimeters.

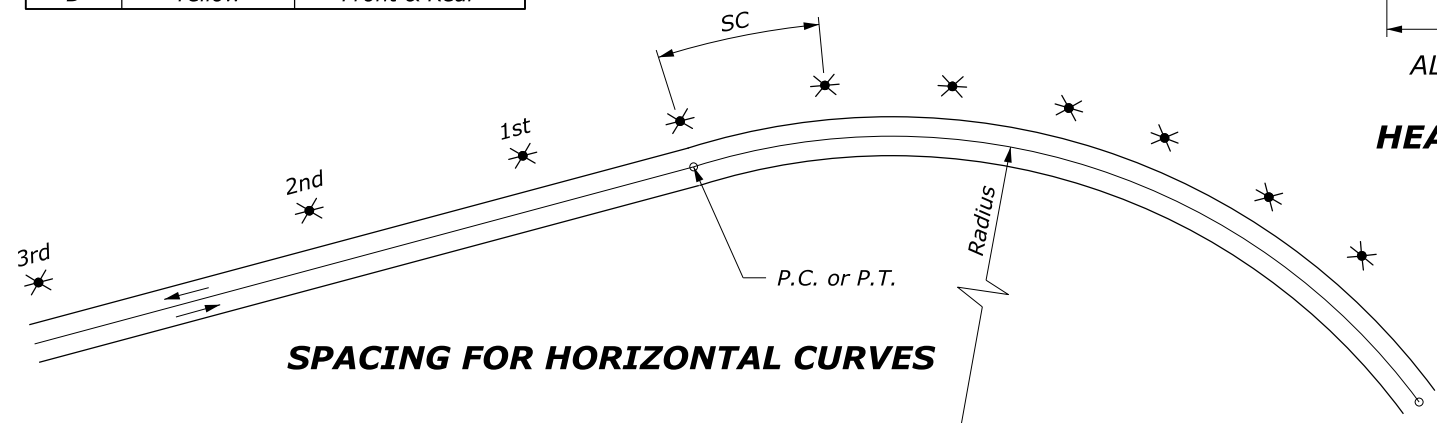

**SPACING FOR HORIZONTAL CURVES**

CURVE RADIUS (METERS)	HORIZONTAL CURVES			
	SPACING ON EACH SIDE OF ROADWAY (METERS)			
	ON CURVE *	IN ADVANCE OF & BEYOND CURVE		
		1st SPACE	2nd SPACE	3rd SPACE
3000	90	90	90	90
1500	64	90	90	90
1200	57	90	90	90
900	49	90	90	90
600	40	80	90	90
300	28	56	84	90
270	26	52	78	90
240	25	50	75	90
210	23	46	69	90
180	22	44	66	90
150	19	38	57	90
120	17	34	51	90
90	14	28	42	84
75	13	26	39	78
60	11	22	33	66
45	9	18	27	54
30	6	12	18	36
25	6	12	18	36

\* Spacing for specific radii not shown may be interpolated from the formula:  $Spacing = 1.65 \sqrt{R-15}$   
(Minimum spacing: 6 m; Maximum spacing: 90 m)

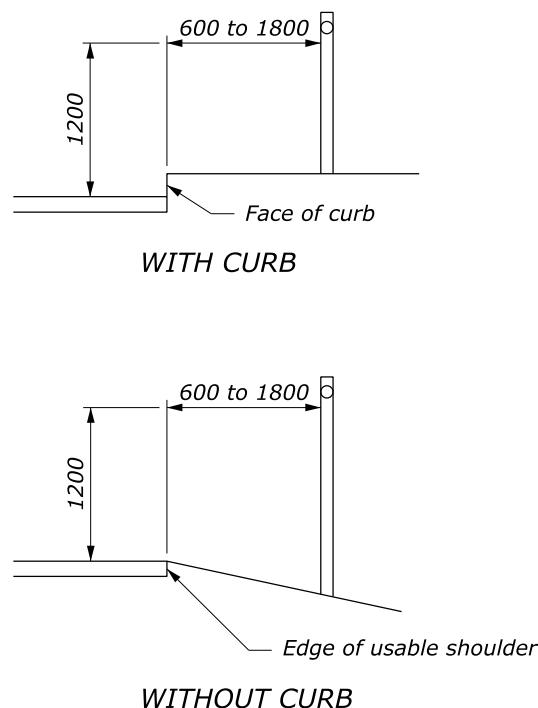

**TYPICAL INSTALLATION**

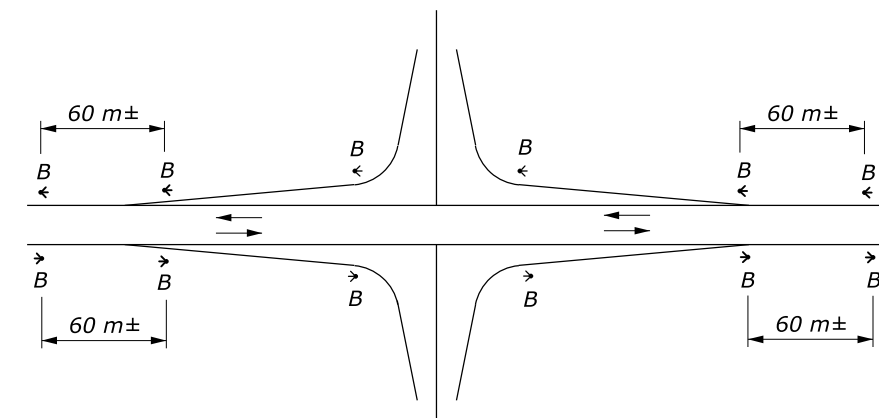
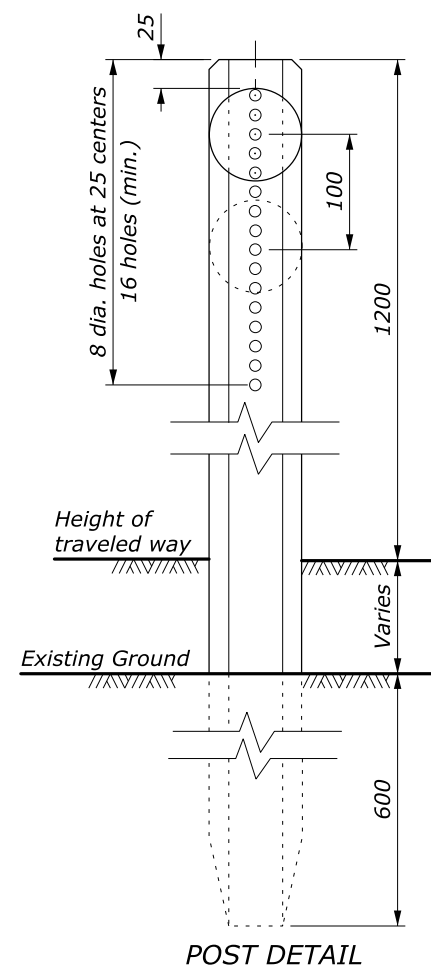

**Two Way Road ROAD INTERSECTIONS**

U.S. DEPARTMENT OF TRANSPORTATION FEDERAL HIGHWAY ADMINISTRATION WESTERN FEDERAL LANDS HIGHWAY DIVISION	
METRIC DETAIL	
<b>ALASKA DELINEATORS</b>	
DETAIL APPROVED FOR USE 3/1996	DETAIL
REVISED: 7/2016	MW633-40

NO SCALE