

**DETAIL A
ANCHOR TRENCH
AT TOP OF SLOPE**

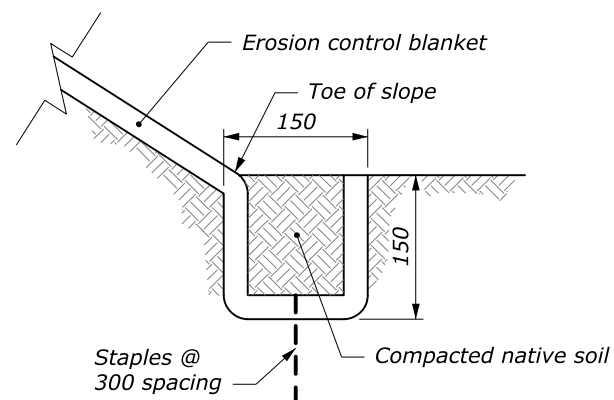

**DETAIL B
ANCHOR TRENCH
AT TOE OF SLOPE**

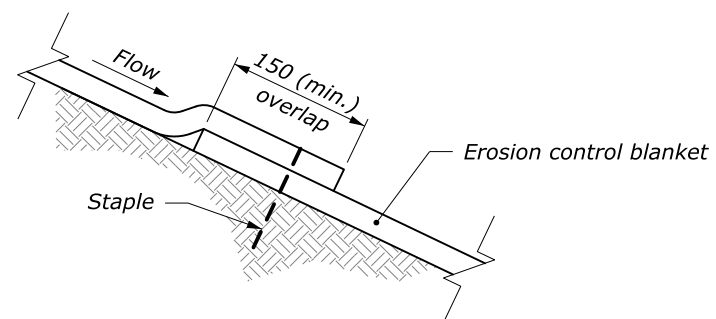

**DETAIL C
SHINGLE SPLICE**

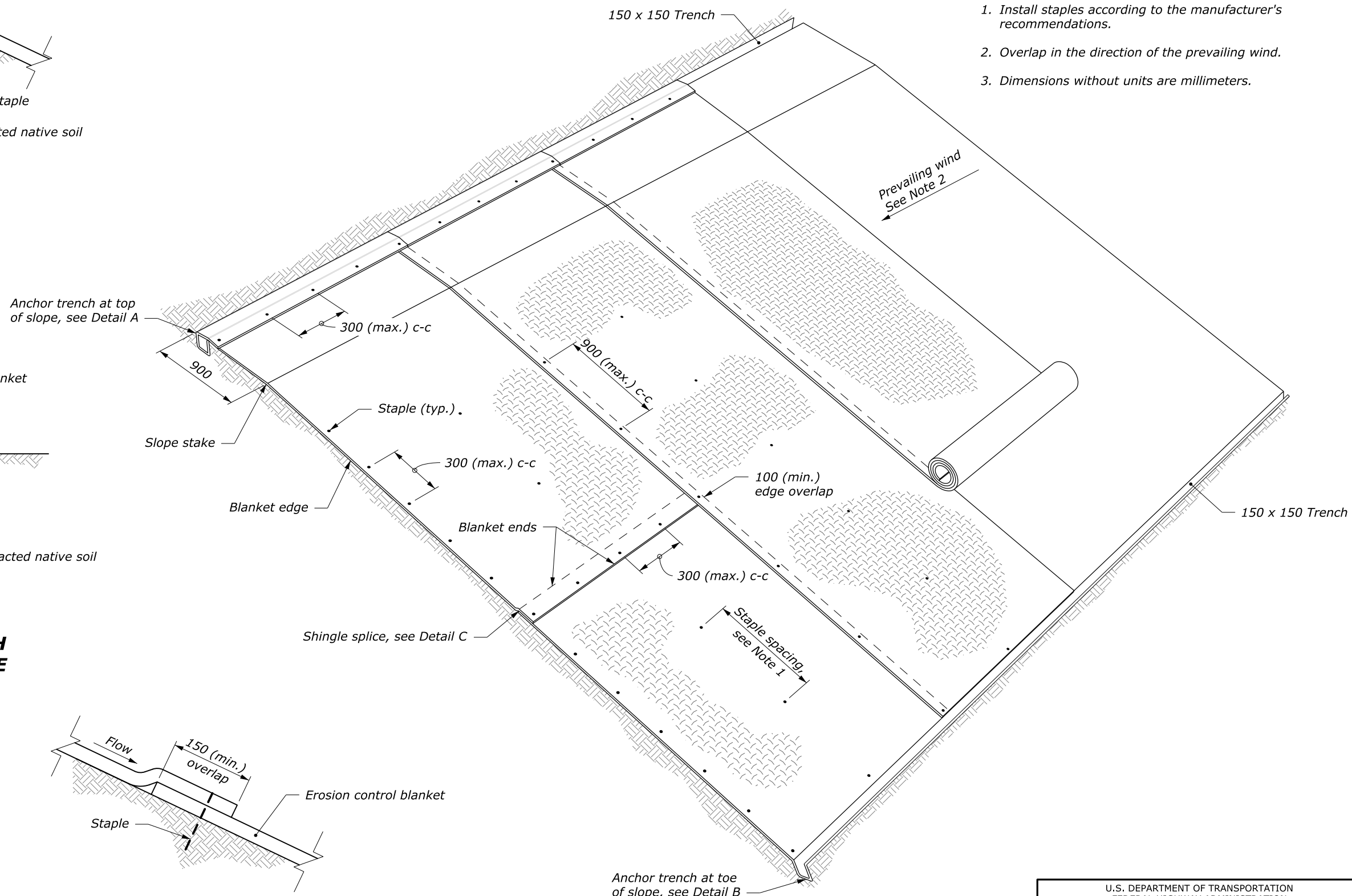

PERSPECTIVE VIEW

NOTE:

1. Install staples according to the manufacturer's recommendations.
2. Overlap in the direction of the prevailing wind. See Note 2.
3. Dimensions without units are millimeters.

U.S. DEPARTMENT OF TRANSPORTATION FEDERAL HIGHWAY ADMINISTRATION WESTERN FEDERAL LANDS HIGHWAY DIVISION	
METRIC DETAIL	
ROLLED EROSION CONTROL PRODUCT ON SLOPES	
DETAIL APPROVED FOR USE --/----	DETAIL
REVISED: 10/2016	MW629-1

NO SCALE