

INTERLOCKING WIRE FASTENER

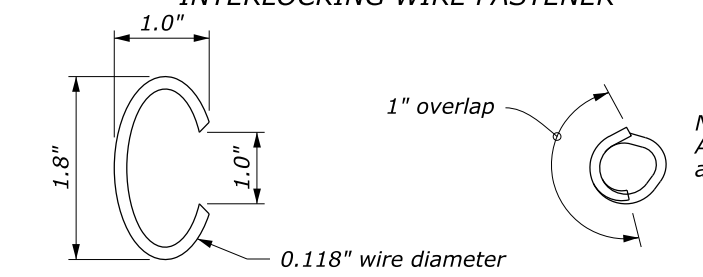

OVERLAPPING RING WIRE FASTENER

ALTERNATE TYING FASTENERS
(Not allowed for basket to basket connection)

NOTE:
All dimensions
are nominal

NOTE:
All dimensions
are nominal

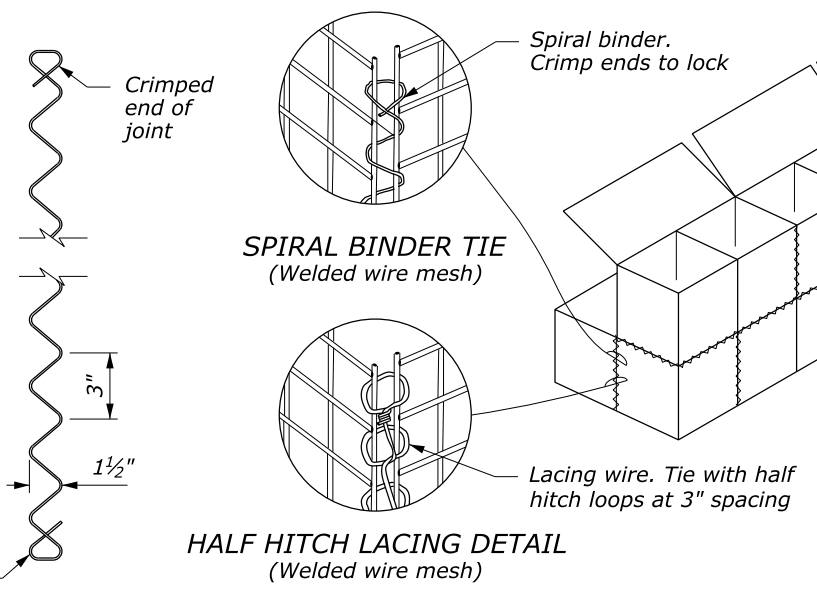

SPIRAL BINDER TIE
(Welded wire mesh)

HALF HITCH LACING DETAIL
(Welded wire mesh)

HALF HITCH LACING DETAIL
(Twisted wire mesh)

TYPICAL INSTALLATION GABION BASKETS

0.150" DIAMETER SPIRAL BINDER

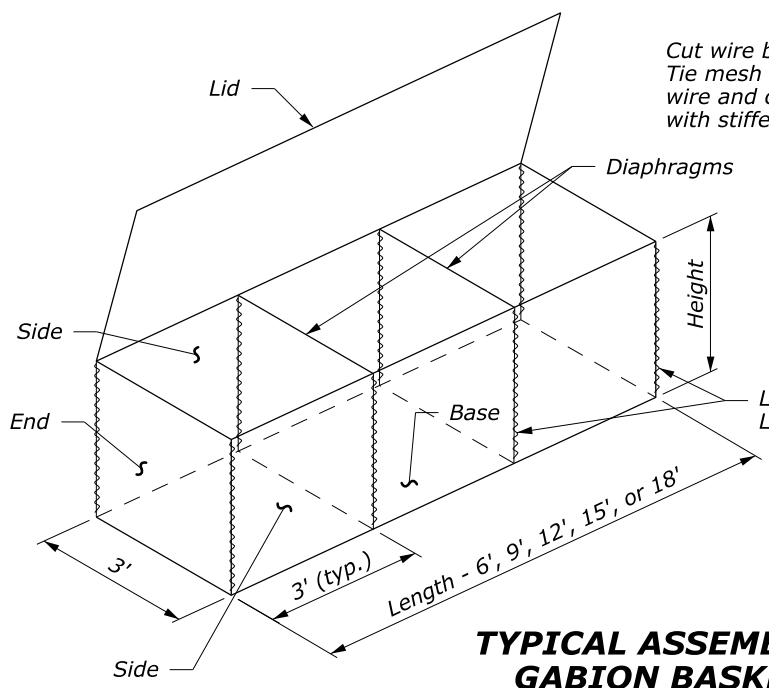

TYPICAL ASSEMBLED GABION BASKET

Cut wire basket mesh front and back. Tie mesh with 0.150" diameter selvage wire and connect front and back mesh with stiffeners to prevent wall bulging.

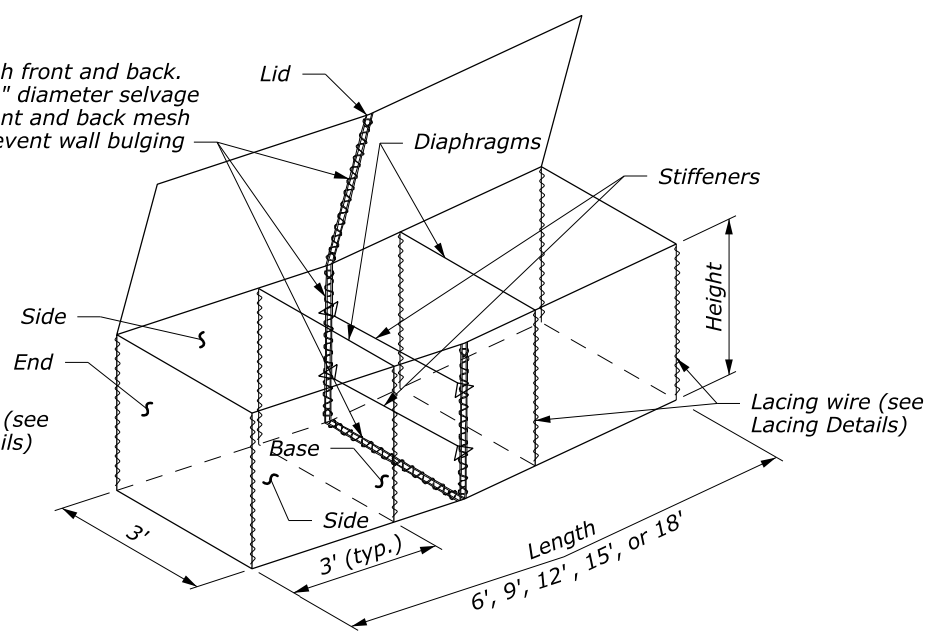

ASSEMBLED GABION BASKET IN WALL GRADE TRANSITION AREAS

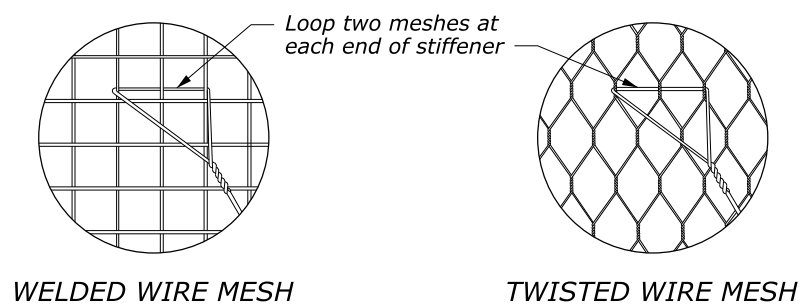

WELDED WIRE MESH

TWISTED WIRE MESH

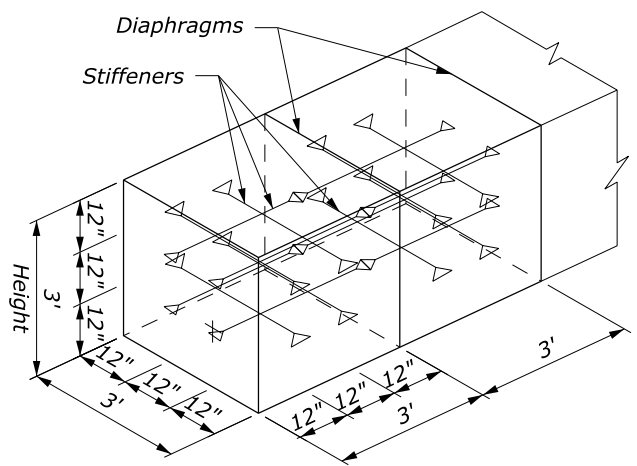

ALL END GABION CELLS

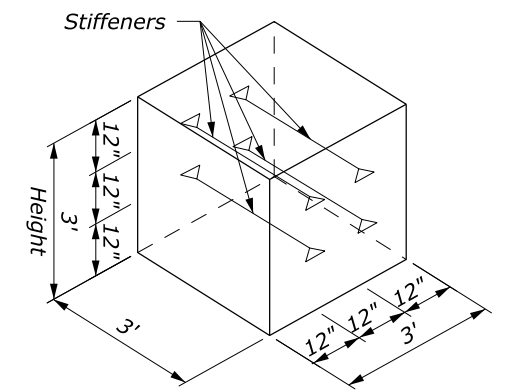

ALL INTERIOR GABION CELLS

TYPICAL STIFFENERS

GABION BASKET NOMINAL SIZES AND CAPACITY				
Size Code Letter	Size in feet		Diaphragm Partitions	Capacity (CUYD)
	Length	Height		
A	6	3.0	1	2.00
B	9	3.0	2	3.00
C	12	3.0	3	4.00
X	15	3.0	4	5.00
Y	18	3.0	5	6.00
D	6	1.5	1	1.00
E	9	1.5	2	1.50
F	12	1.5	3	2.00
G	6	1.0	1	0.67
H	9	1.0	2	1.00
I	12	1.0	3	1.33

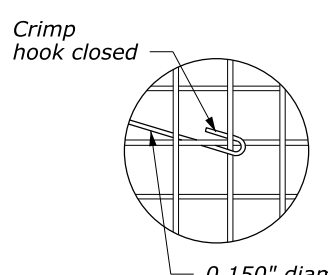

0.150" diameter stiffener hooked at intersection of wires

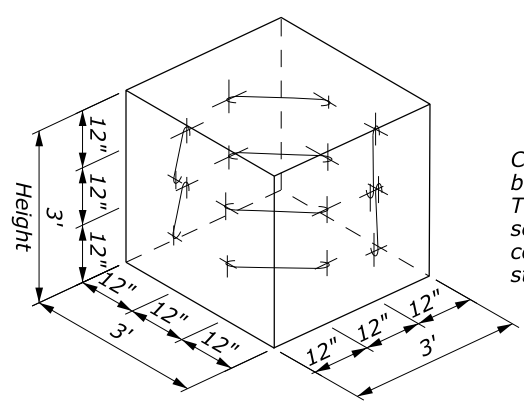

ALL GABION CELLS

OPTIONAL STIFFENERS WELDED WIRE GABION BASKET

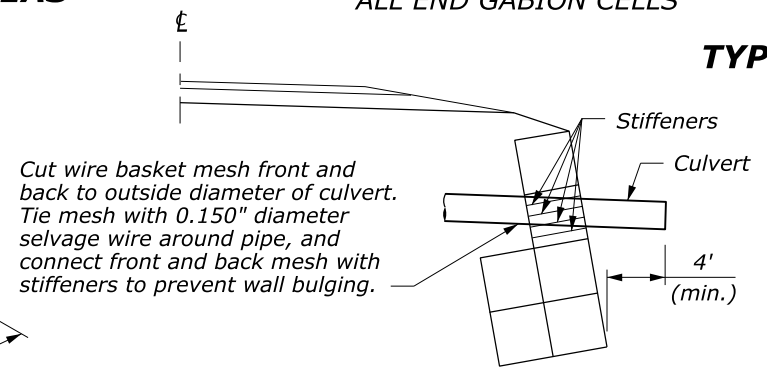

TYPICAL CULVERT INSTALLATION THROUGH GABION WALL

NO SCALE

U.S. DEPARTMENT OF TRANSPORTATION
FEDERAL HIGHWAY ADMINISTRATION
WESTERN FEDERAL LANDS HIGHWAY DIVISION

U.S. CUSTOMARY DETAIL

GABION BASKET

DETAIL APPROVED FOR USE --/---
REVISED: 9/2011
DRAFT: 9/2011

DETAIL
W253-1

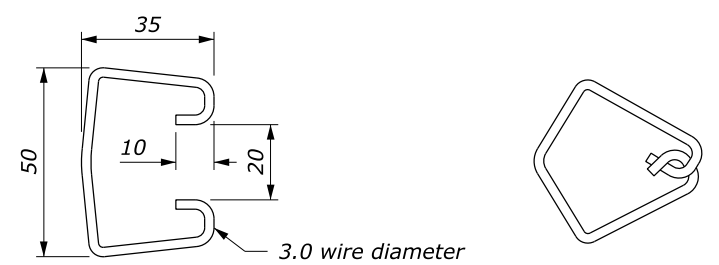

NOTE:
All dimensions are nominal

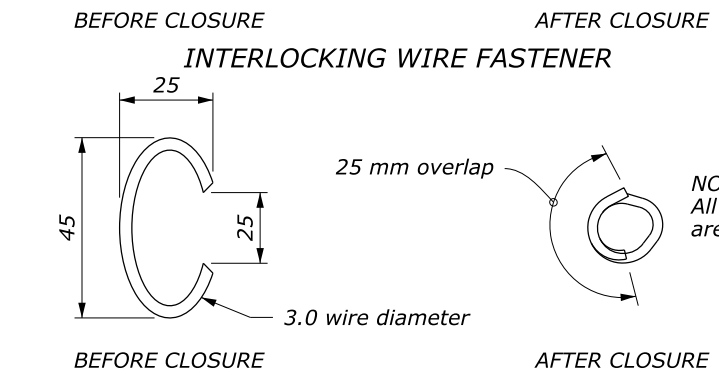

NOTE:
All dimensions are nominal

INTERLOCKING WIRE FASTENER
ALTERNATE TYING FASTENERS

3.8 mm DIAMETER SPIRAL BINDER

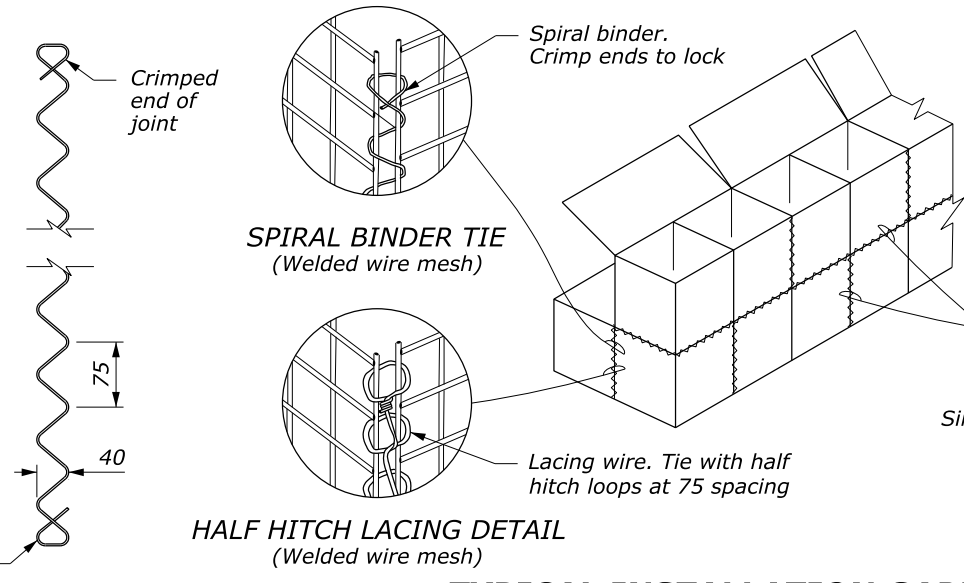

NOTE:
1. Dimensions not labeled are in millimeters.

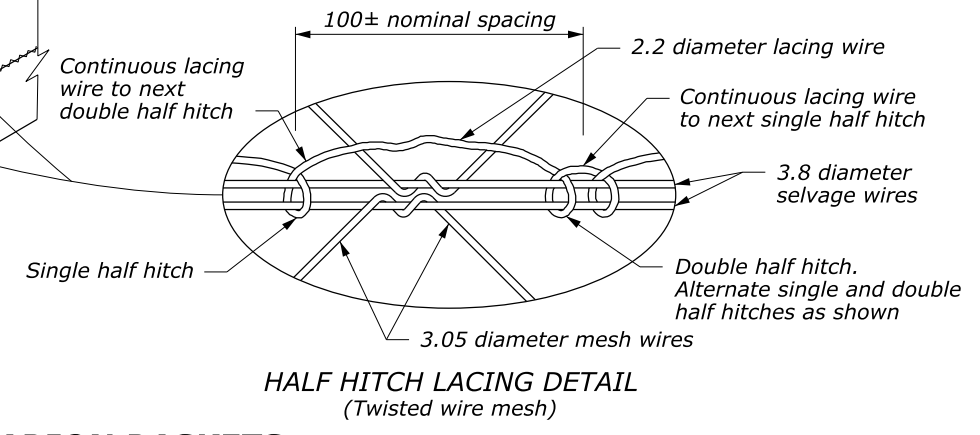

TYPICAL INSTALLATION GABION BASKETS

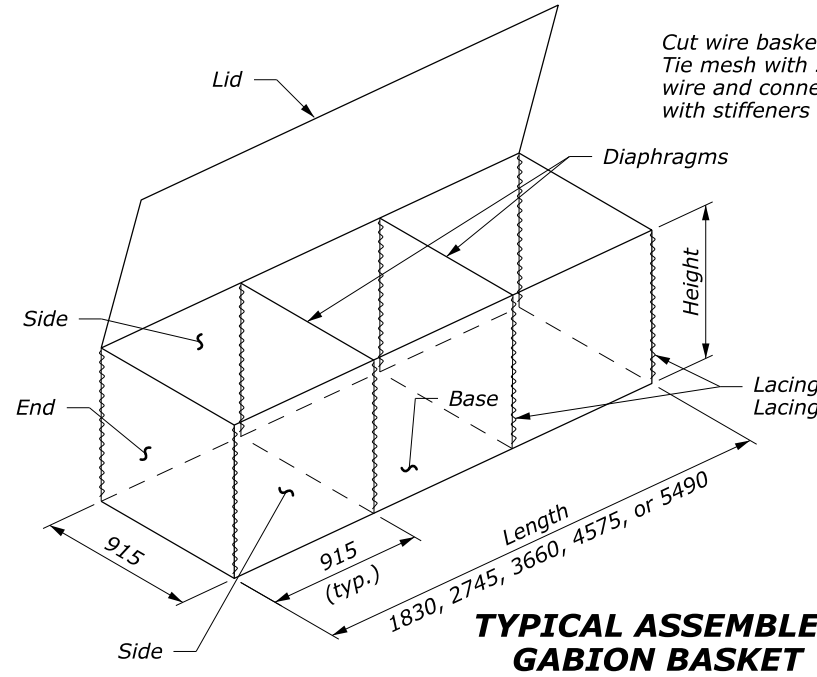

TYPICAL ASSEMBLED GABION BASKET

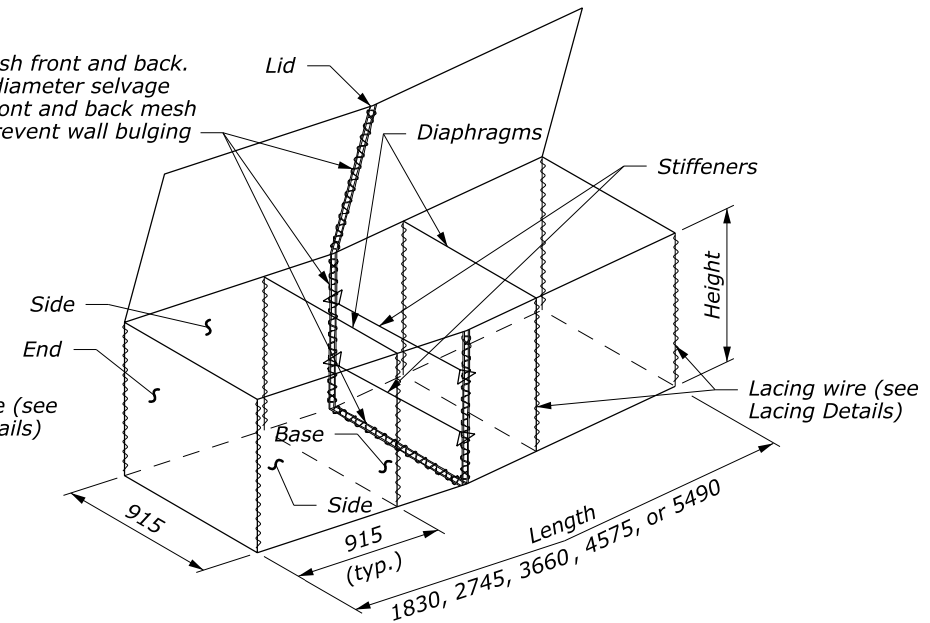

ASSEMBLED GABION BASKET IN WALL GRADE TRANSITION AREAS

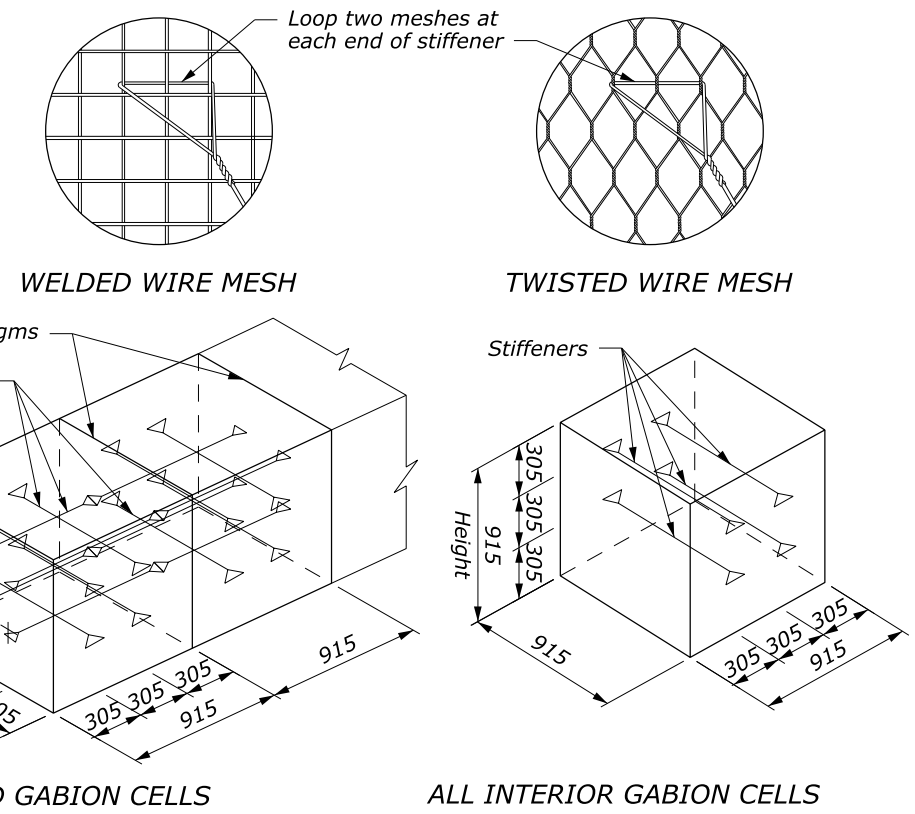

TYPICAL STIFFENERS

GABION BASKET NOMINAL SIZES AND CAPACITY				
Size Code Letter	Size in meters		Diaphragm Partitions	Capacity (m ³)
	Length	Height		
A	1.83	0.915	1	1.5
B	2.75	0.915	2	2.3
C	3.66	0.915	3	3.1
X	4.58	0.915	4	3.8
Y	5.49	0.915	5	4.6
D	1.83	0.45	1	0.8
E	2.75	0.45	2	1.1
F	3.66	0.45	3	1.5
G	1.83	0.30	1	0.5
H	2.75	0.30	2	0.8
I	3.66	0.30	3	1.0

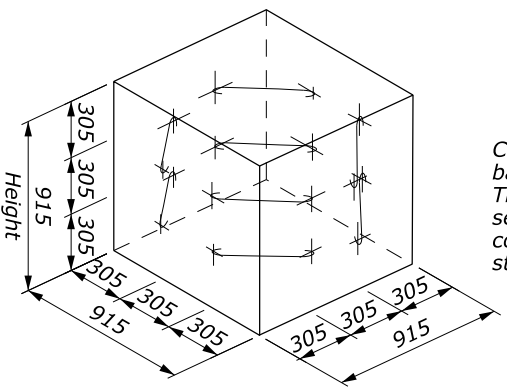
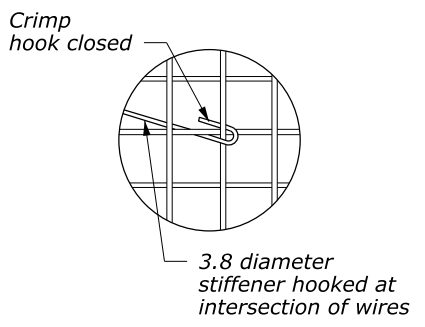

ALL GABION CELLS
OPTIONAL STIFFENERS WELDED WIRE GABION BASKET

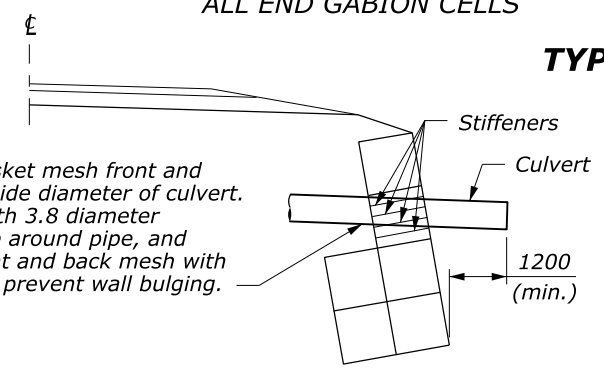

TYPICAL CULVERT INSTALLATION THROUGH GABION WALL

NO SCALE

U.S. DEPARTMENT OF TRANSPORTATION
FEDERAL HIGHWAY ADMINISTRATION
WESTERN FEDERAL LANDS HIGHWAY DIVISION

METRIC DETAIL

GABION BASKET

DETAIL APPROVED FOR USE --/----

REVIS: 9/2011

DETAIL WM253-1

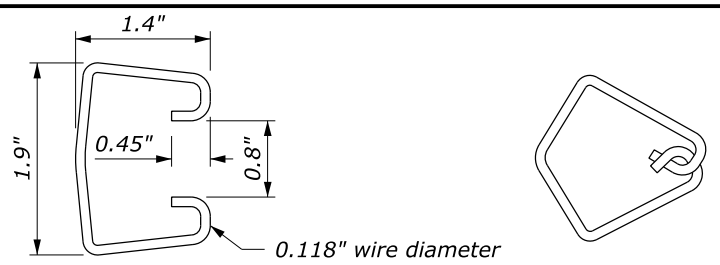

BEFORE CLOSURE AFTER CLOSURE
INTERLOCKING WIRE FASTENER

NOTE:
All dimensions
are nominal

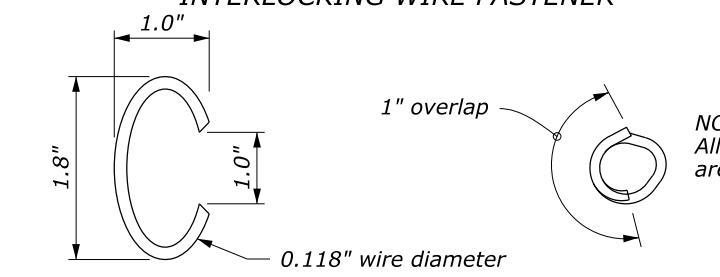

BEFORE CLOSURE AFTER CLOSURE
OVERLAPPING RING WIRE FASTENER

ALTERNATE TYING FASTENERS

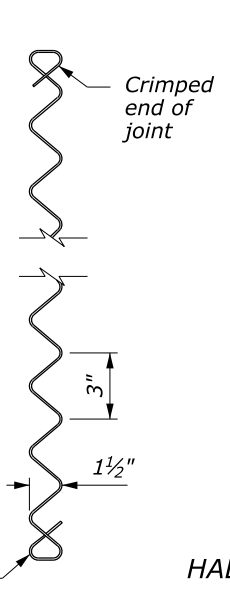

0.150" DIAMETER SPIRAL BINDER

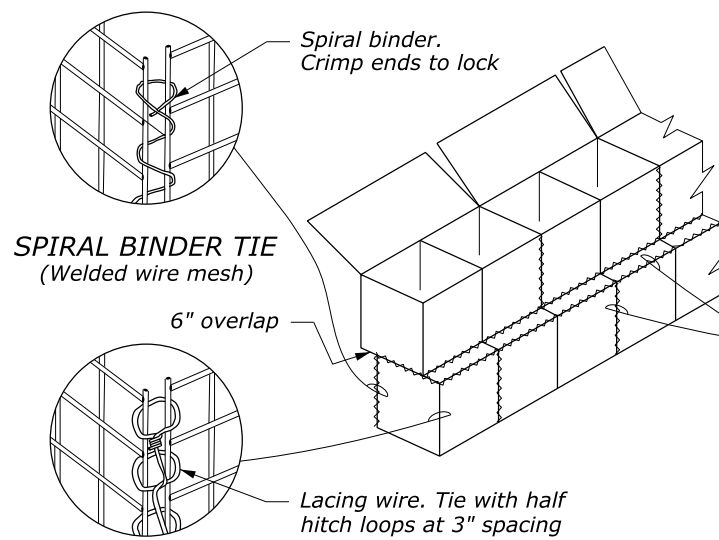

HALF HITCH LACING DETAIL (Welded wire mesh)

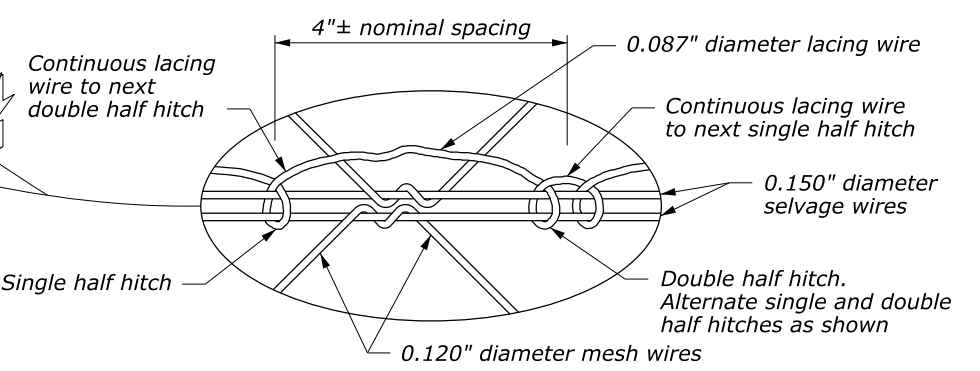

HALF HITCH LACING DETAIL (Twisted wire mesh)

TYPICAL INSTALLATION GABION BASKETS

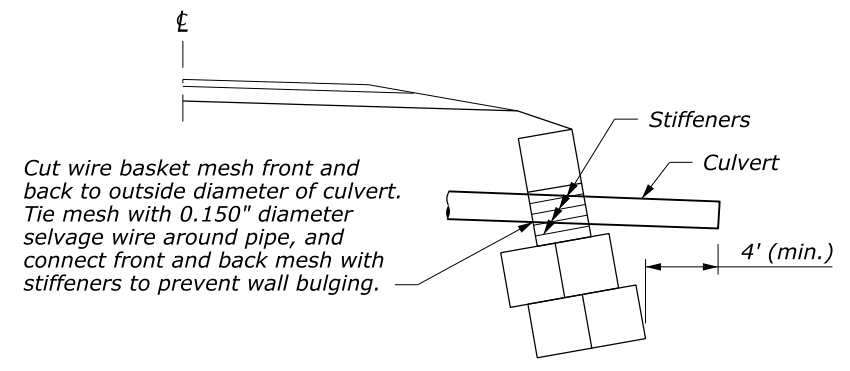

TYPICAL CULVERT INSTALLATION THROUGH GABION WALL

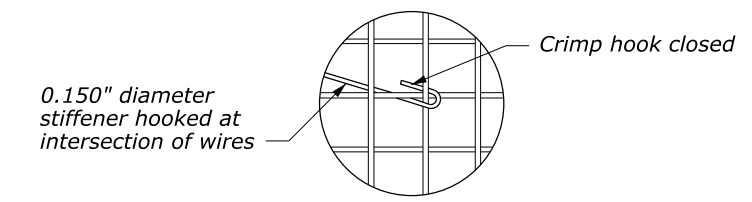

OPTIONAL STIFFENERS WELDED WIRE GABION BASKET

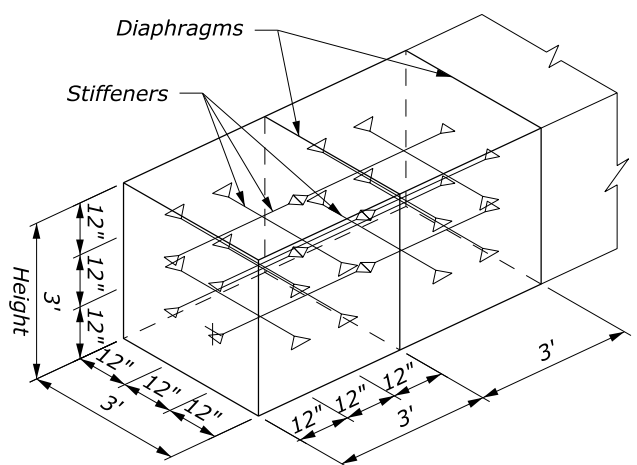
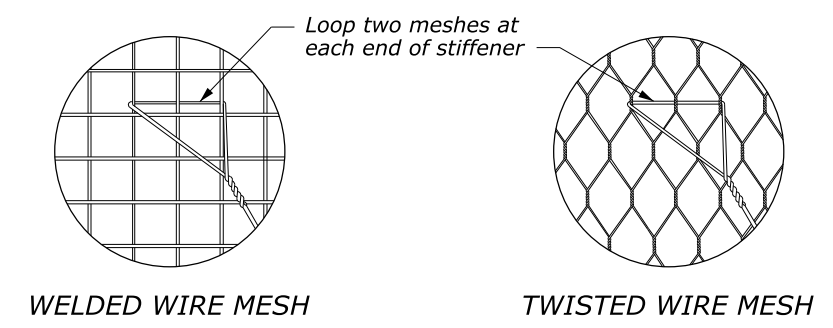

ALL END GABION CELLS

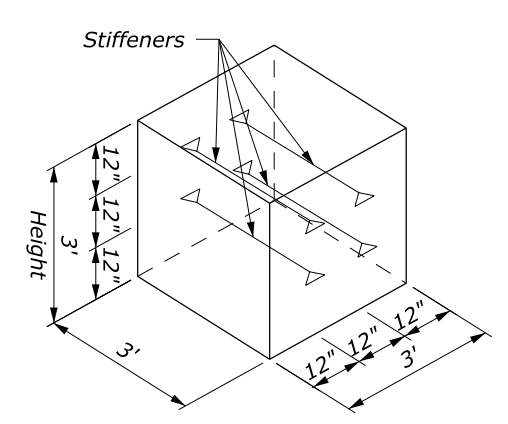

ALL INTERIOR GABION CELLS

TYPICAL STIFFENERS

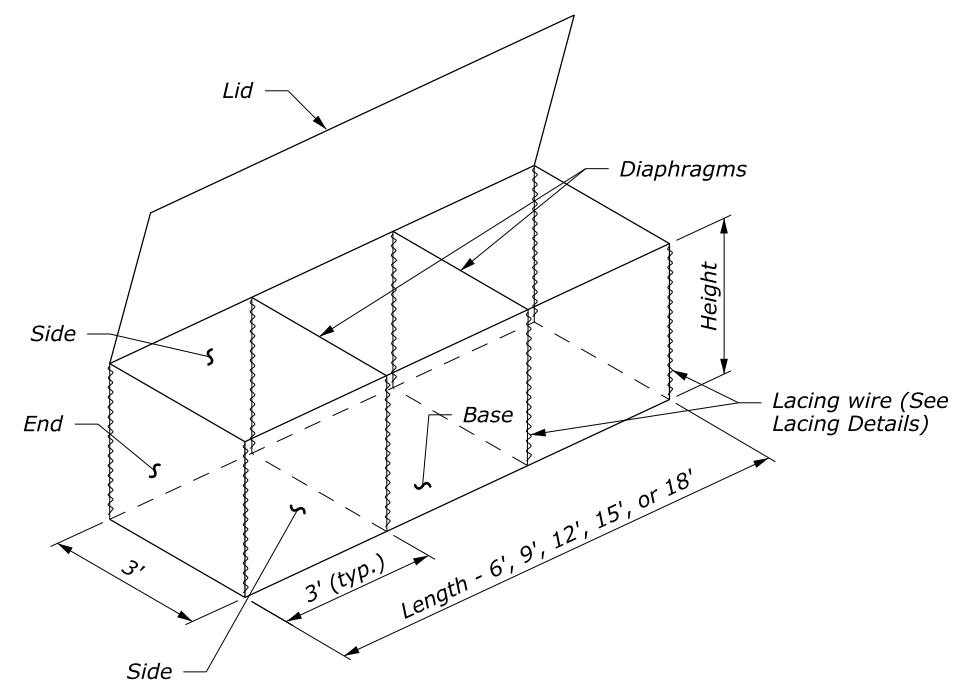

TYPICAL ASSEMBLED GABION BASKET

GABION BASKET NOMINAL SIZES AND CAPACITY				
Size Code Letter	Size in feet		Diaphragm Partitions	Capacity (CUYD)
	Length	Height		
A	6	3	1	2
B	9	3	2	3
C	12	3	3	4
X	15	3	4	5
Y	18	3	5	6

NO SCALE

U.S. DEPARTMENT OF TRANSPORTATION FEDERAL HIGHWAY ADMINISTRATION WESTERN FEDERAL LANDS HIGHWAY DIVISION	
U.S. CUSTOMARY DETAIL	
GABION FACED WALL	
DETAIL APPROVED FOR USE --/---	DETAIL W253-2
REVISED: 9/2011	DRAFT: 9/2011

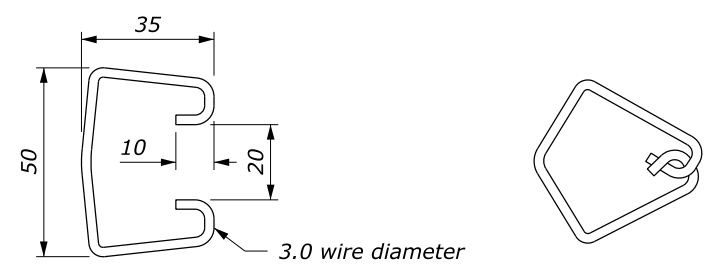

BEFORE CLOSURE AFTER CLOSURE
INTERLOCKING WIRE FASTENER

NOTE:
All dimensions are nominal

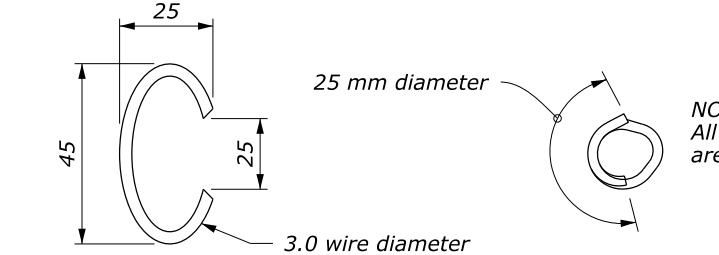

BEFORE CLOSURE AFTER CLOSURE
**OVERLAPPING RING WIRE FASTENER
ALTERNATE TYING FASTENERS**

NOTE:
All dimensions are nominal

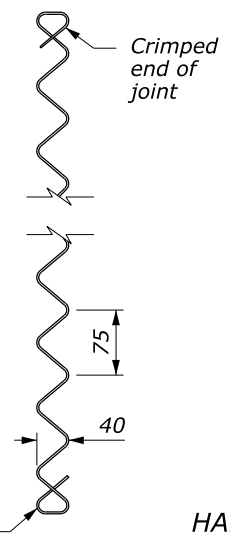

**3.8 mm DIAMETER
SPIRAL BINDER**

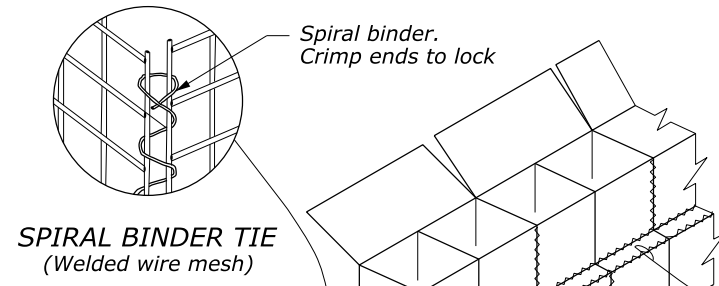

**SPIRAL BINDER TIE
(Welded wire mesh)**

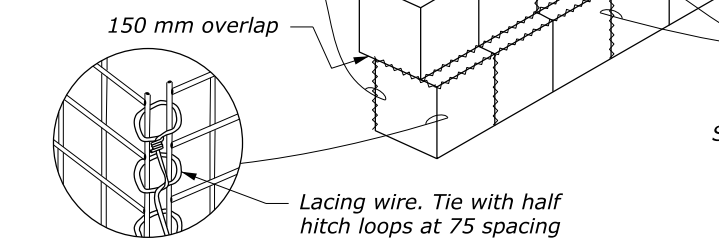

**HALF HITCH LACING DETAIL
(Welded wire mesh)**

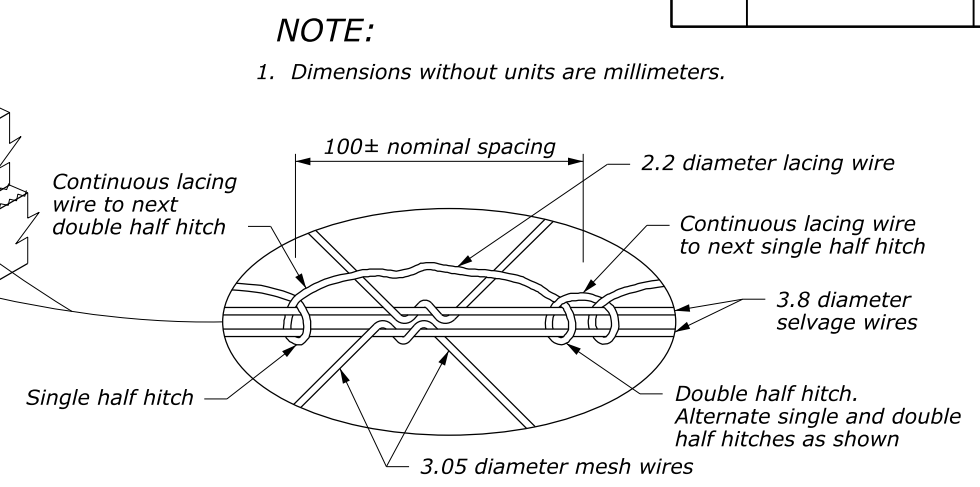

NOTE:

1. Dimensions without units are millimeters.

**HALF HITCH LACING DETAIL
(Twisted wire mesh)**

TYPICAL INSTALLATION GABION BASKETS

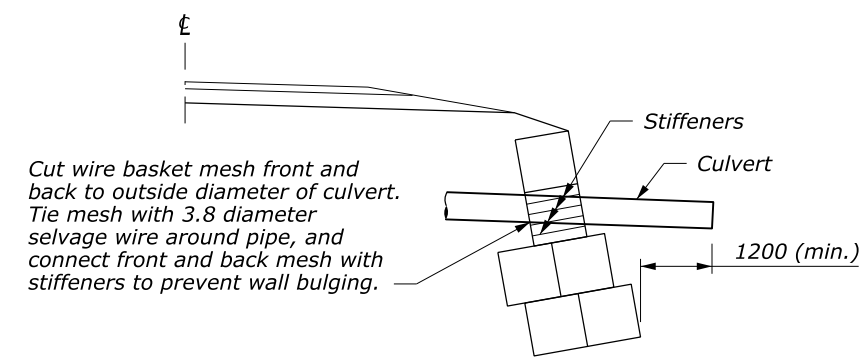

**TYPICAL CULVERT INSTALLATION
THROUGH GABION WALL**

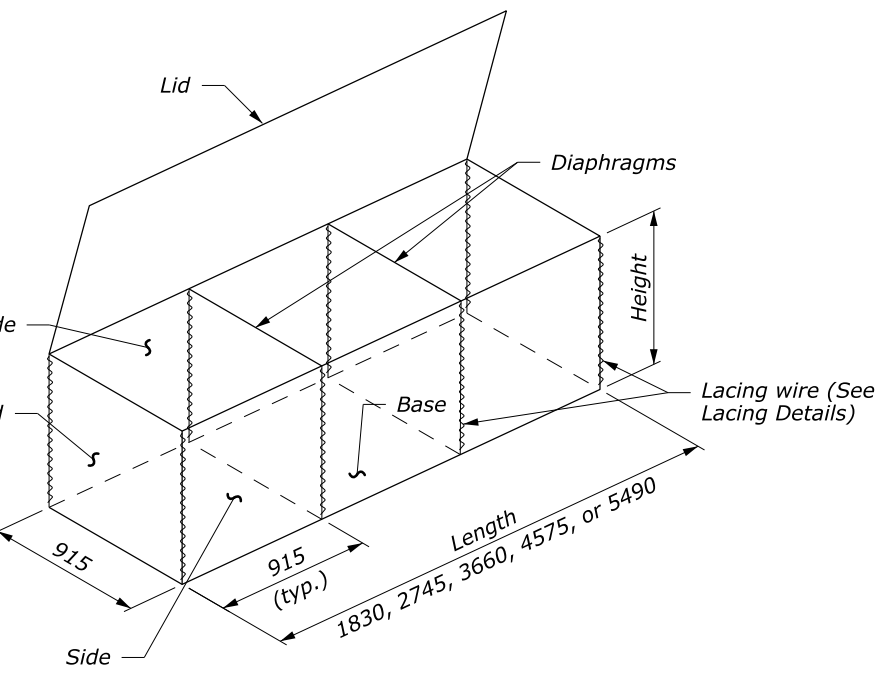

TYPICAL ASSEMBLED GABION BASKET

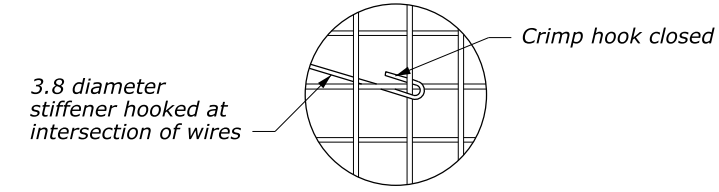

3.8 diameter stiffener hooked at intersection of wires

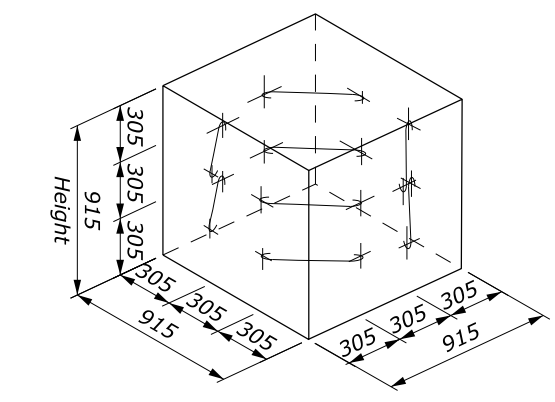

**ALL GABION CELLS
OPTIONAL STIFFENERS
WELDED WIRE GABION BASKET**

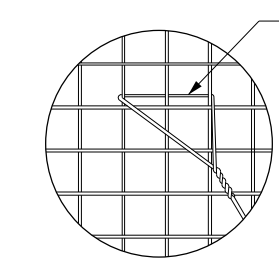

WELDED WIRE MESH

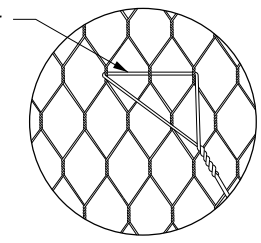

TWISTED WIRE MESH

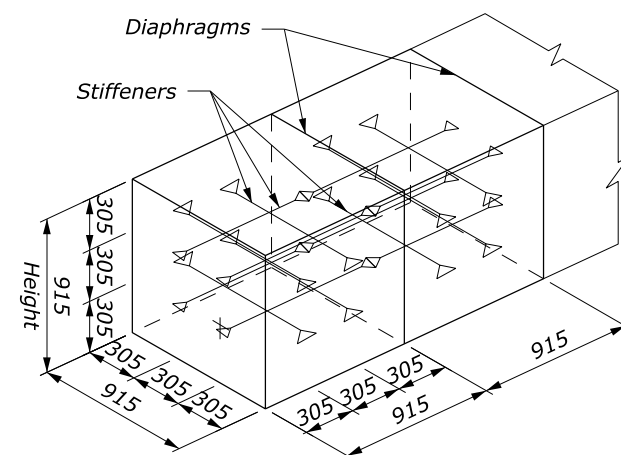

ALL END GABION CELLS

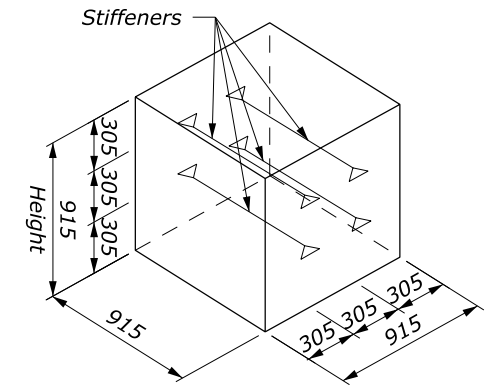

ALL INTERIOR GABION CELLS

TYPICAL STIFFENERS

Size Code Letter	Size in meters		Diaphragm Partitions	Capacity m3
	Length	Height		
A	1.83	0.915	1	1.5
B	2.75	0.915	2	2.3
C	3.66	0.915	3	3.1
X	4.58	0.915	4	3.8
Y	5.49	0.915	5	4.6

NO SCALE

U.S. DEPARTMENT OF TRANSPORTATION
FEDERAL HIGHWAY ADMINISTRATION
WESTERN FEDERAL LANDS HIGHWAY DIVISION

METRIC DETAIL

GABION FACED WALL

DETAIL APPROVED FOR USE --/----

REVISID: 9/2011
DRAFT: 9/2011

DETAIL WM253-2

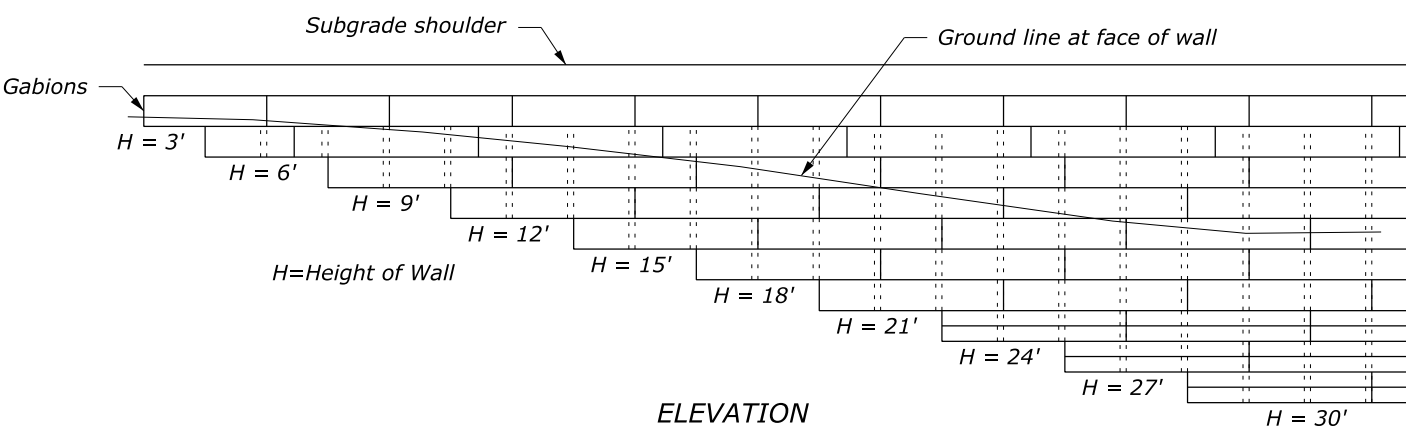
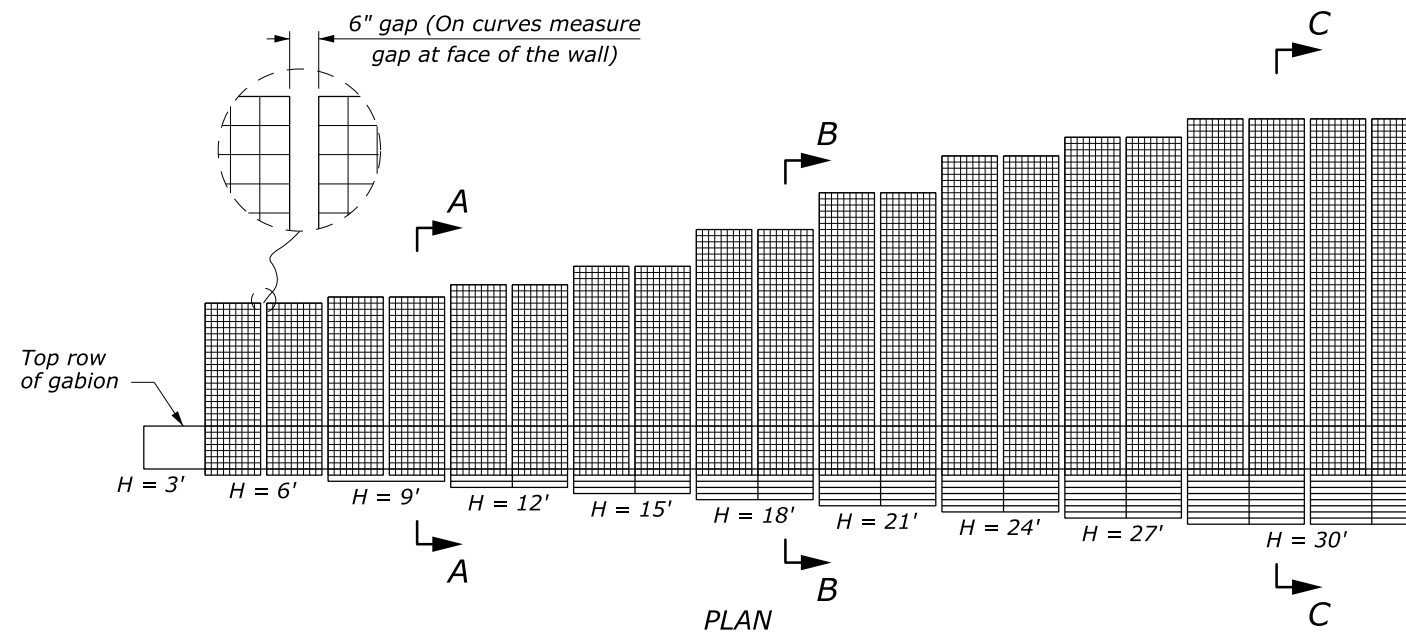

TYPICAL GABION WALL

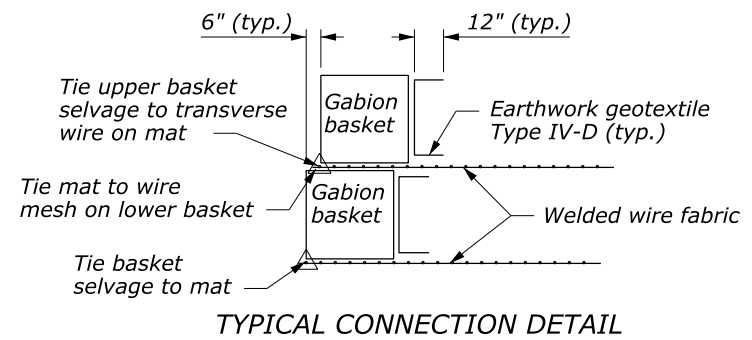

NOTE:

1. The welded wire fabric sheets vary in length within each wall. The height (H) of the vertical face of the wall determines the length of the welded wire fabric for the entire section. See other plan sheets for fabric lengths, wire sizes and spacing and number of mats. Where the wall construction requires the width of the welded wire fabric sheets to be less than 5.5 feet, the fabric wire may be field cut to fit. Cut fabric at center of mesh of welded wire fabric sheets.
2. Place layers of welded wire fabric sheets with 6" gaps between sheets. The 6" gaps are measured at the face of the wall. Connect the welded wire fabric sheets with spiral binders or tie wire to the front edge of each gabion basket.
3. The heights and quantities are subject to field adjustment. Any increase in wall heights over those shown on the plans require investigation to determine that the safe bearing pressure is not exceeded.
4. Average design assumption values. See the Geotechnical Report, if available, for site specific values.
 Unit weight of backfill material 125 pcf
 Unit weight of filled gabions is 105 pcf
 ϕ angle = 35° for backfill material

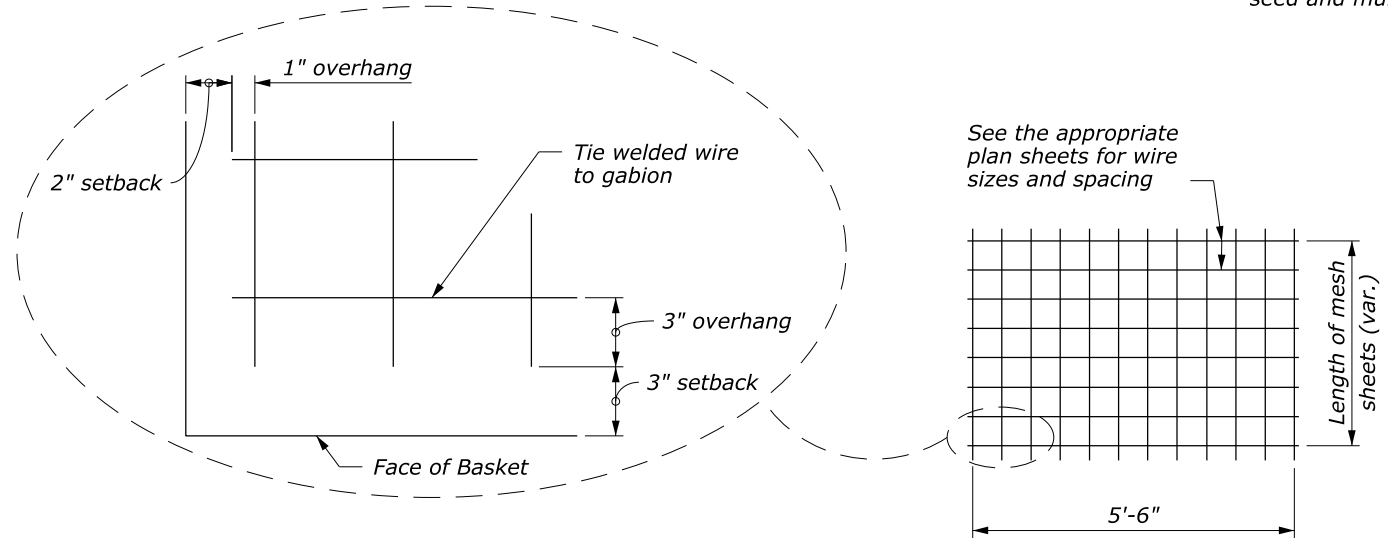
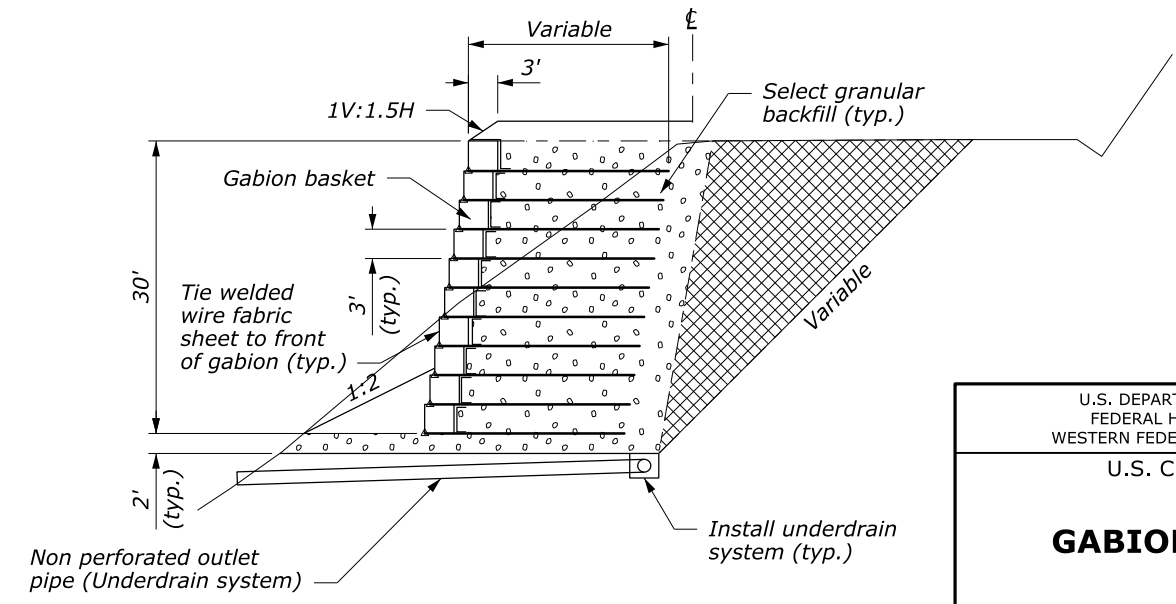
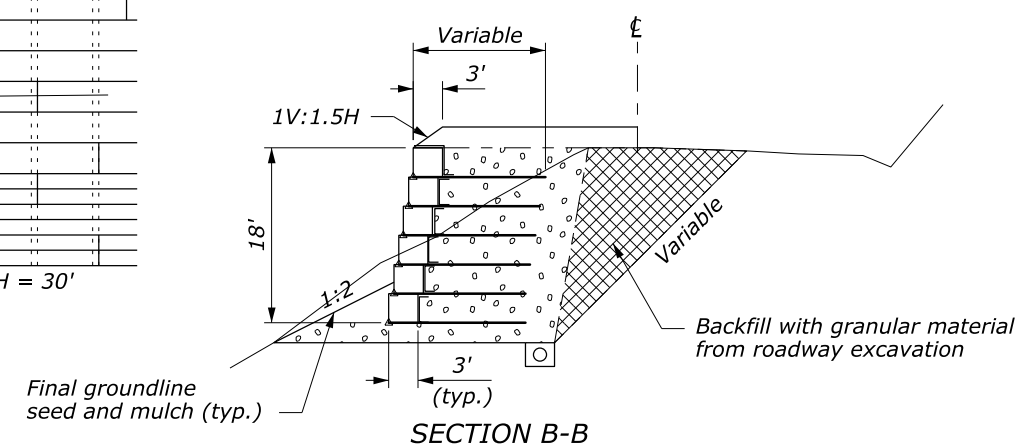
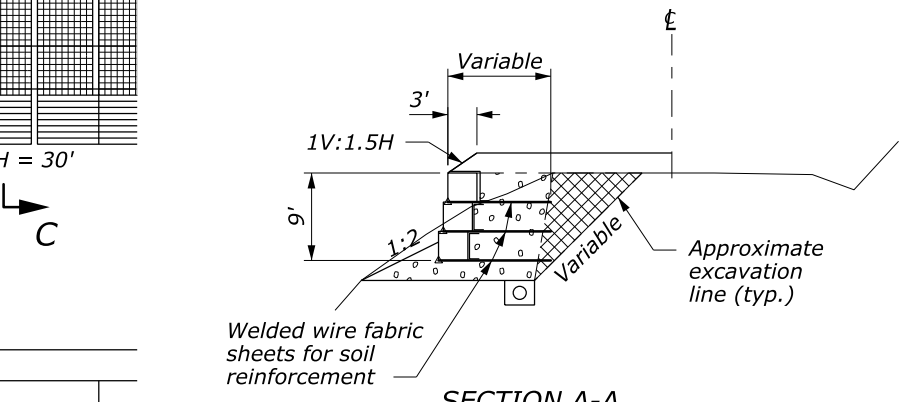

U.S. DEPARTMENT OF TRANSPORTATION
 FEDERAL HIGHWAY ADMINISTRATION
 WESTERN FEDERAL LANDS HIGHWAY DIVISION

U.S. CUSTOMARY DETAIL

GABION FACED WALL

DETAIL APPROVED FOR USE --/---

REVISOR: 9/2011

DETAIL W253-3

c:\myfiles\pw_production\dmms18765\FLH.dgnlib [Detail_US]
 24 August 2011 8:06 AM

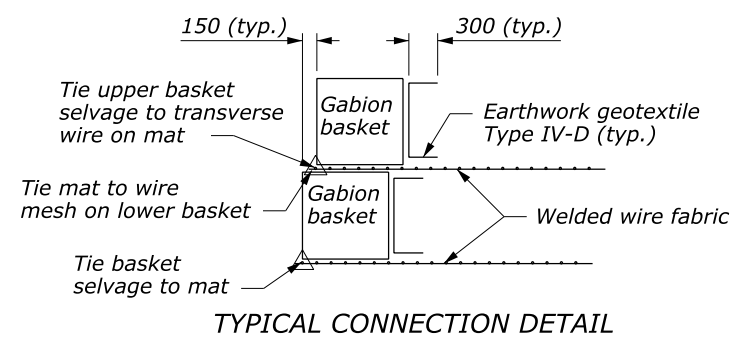
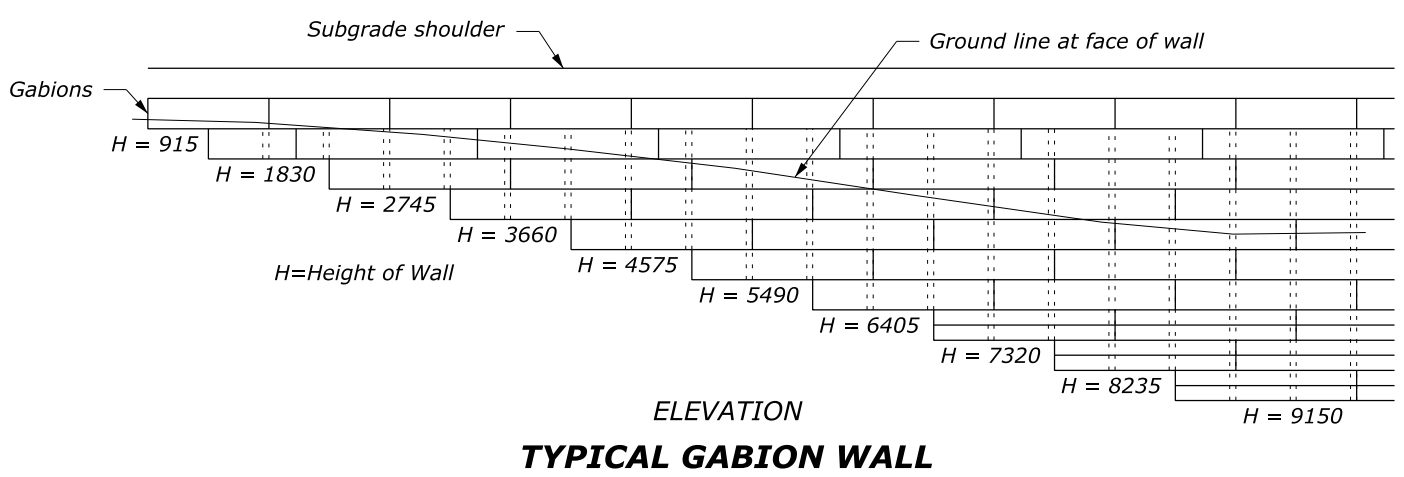
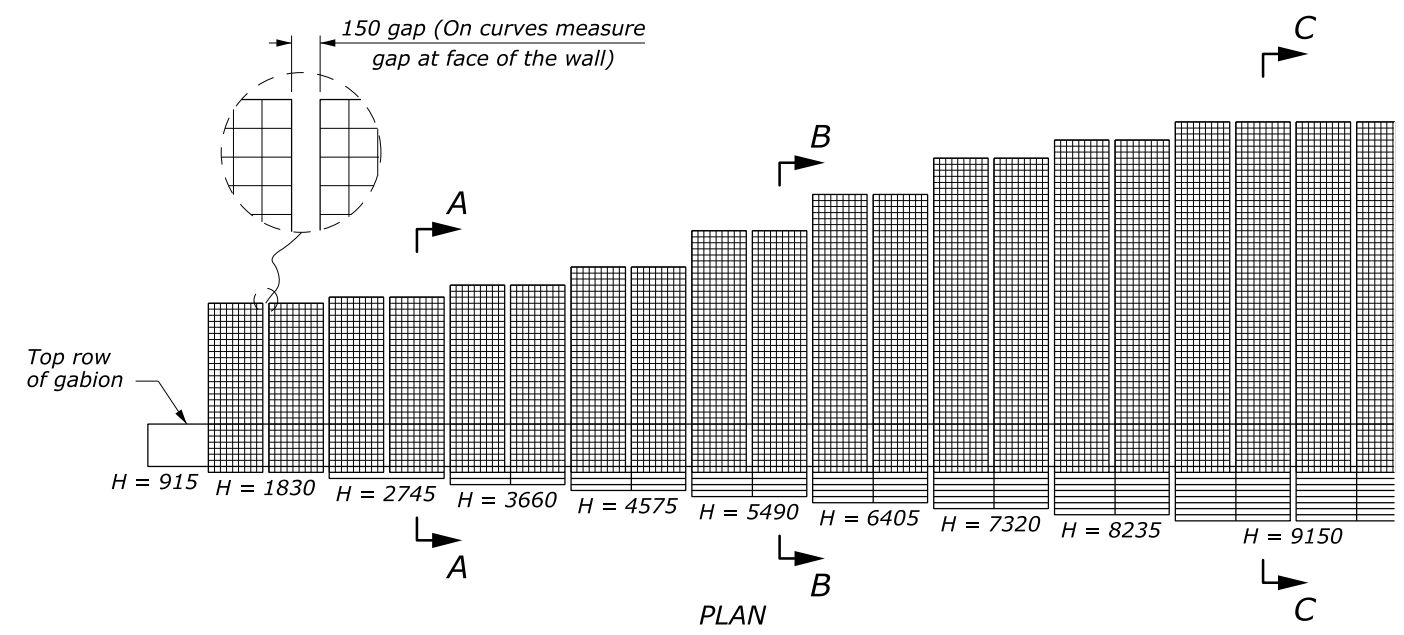

NOTE:

1. The welded wire fabric sheets vary in length within each wall. The height (H) of the vertical face of the wall determines the length of the welded wire fabric for the entire section. See other plan sheets for fabric lengths, wire sizes and spacing and number of mats. Where the wall construction requires the width of the welded wire fabric sheets to be less than 1650 mm, the fabric wire may be field cut to fit. Cut fabric at center of mesh of welded wire fabric sheets.
2. Place layers of welded wire fabric sheets with 150 mm gaps between sheets. The 150 mm gaps are measured at the face of the wall. Connect the welded wire fabric sheets with spiral binders or tie wire to the front edge of each gabion basket.
3. The heights and quantities are subject to field adjustment. Any increase in wall heights over those shown on the plans require investigation to determine that the safe bearing pressure is not exceeded.
4. Average design assumption values. See the Geotechnical Report, if available, for site specific values.
Unit weight of backfill material 20.8 kN/m³
Unit weight of filled gabions is 17.6 kN/m³
Ø angle = 35° for backfill material
5. Dimensions without units are millimeters.

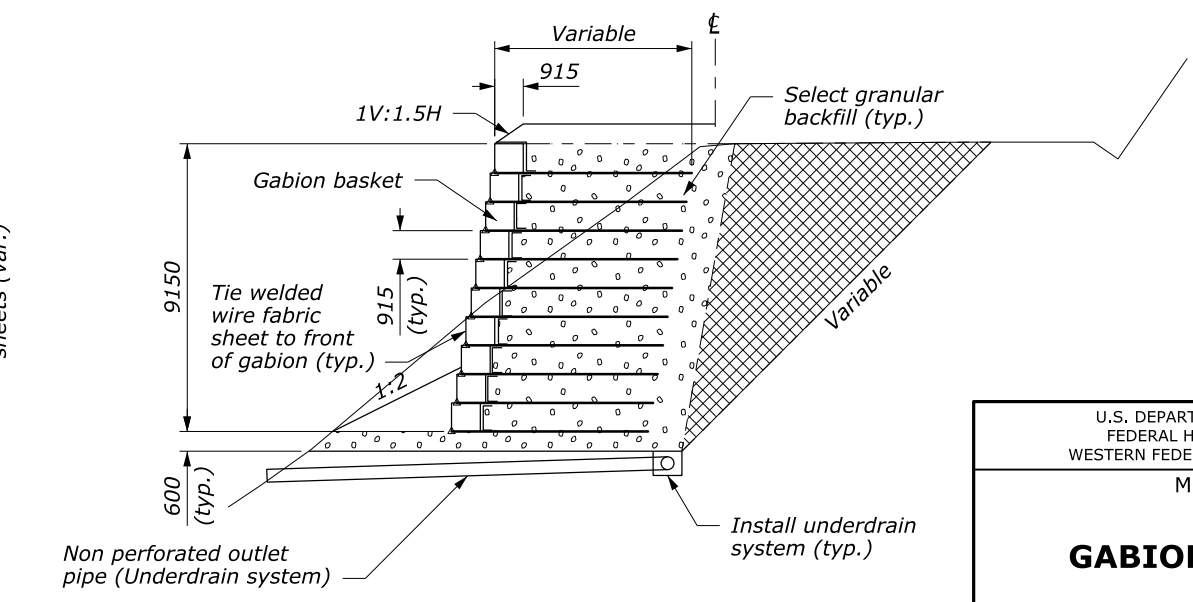
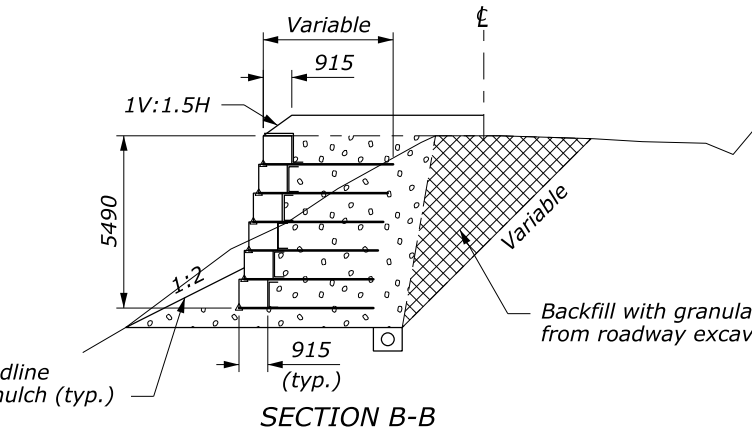
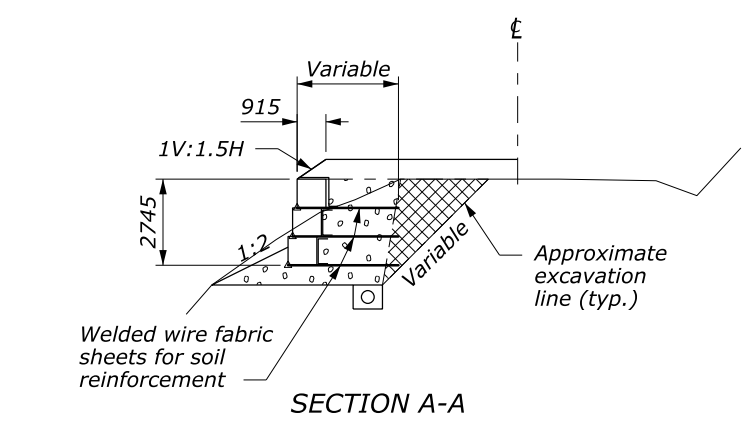

NO SCALE

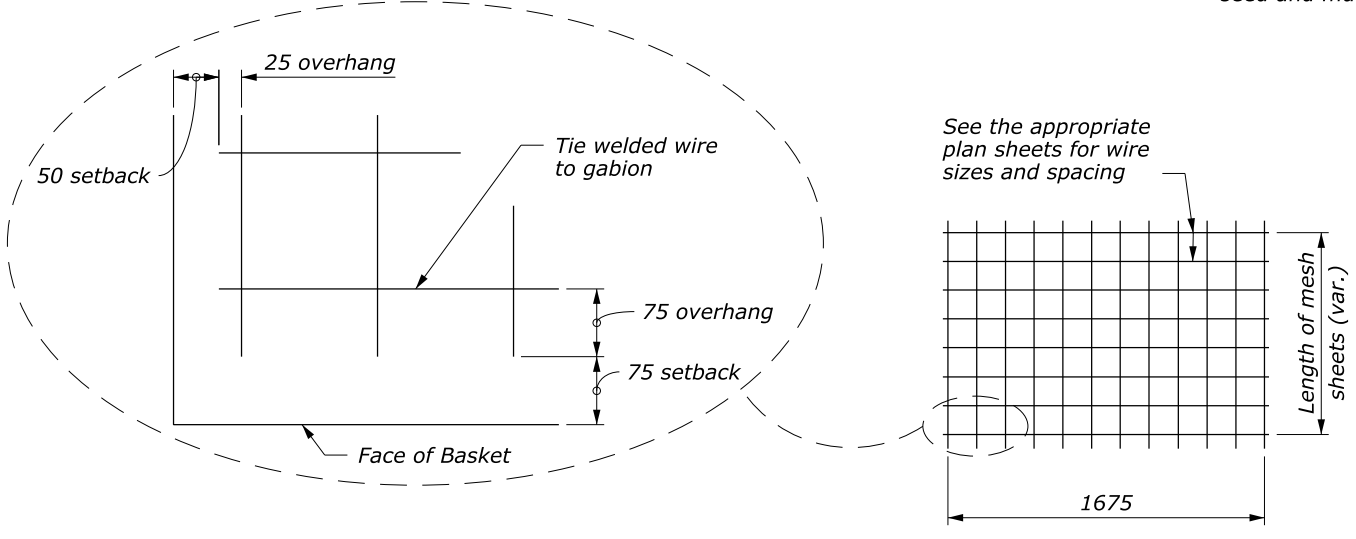

U.S. DEPARTMENT OF TRANSPORTATION FEDERAL HIGHWAY ADMINISTRATION WESTERN FEDERAL LANDS HIGHWAY DIVISION	
METRIC DETAIL	
GABION FACED WALL	
DETAIL APPROVED FOR USE --/----	DETAIL
REVISED: DRAFT: 9/2011	WM253-3