

NOTE:

1. Select the inlet protection device to fit field conditions as approved by the CO.
2. Install fiber rolls with stakes spaced no more than 600 mm on center. Drive stakes 300 mm (min.) in undisturbed soil.
3. Approximate finished dimension of gravel bags is 300 mm x 450 mm.
4. Maximum top of gravel bag spillway elevation = Top of curb minus 25 mm.
5. Pack gravel filled bags tightly together end to end to ensure no sediment flows between or underneath the bags. Where tight fit is unachievable, install geotextile filter, class 2, type C along the upstream face of the bags. Place fabric over the top of the bags to the spillway elevation. Anchor the fabric by placing the next layer of bags on top of it. Extend the geotextile fabric a minimum of 450 mm upstream of the bags. Cover geotextile fabric to the top of the fabric with clean, silt-free coarse aggregate between 50 mm and 75 mm in diameter.
6. Size the prefabricated filter insert (Type C) to fit the drop inlet and allow collected material removal without spillage. Include a high-flow bypass in the insert.
7. Dimensions without units are millimeters.

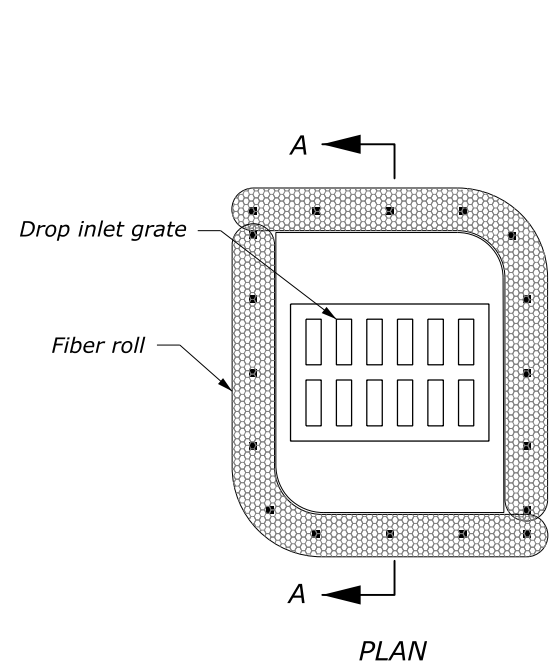

PLAN

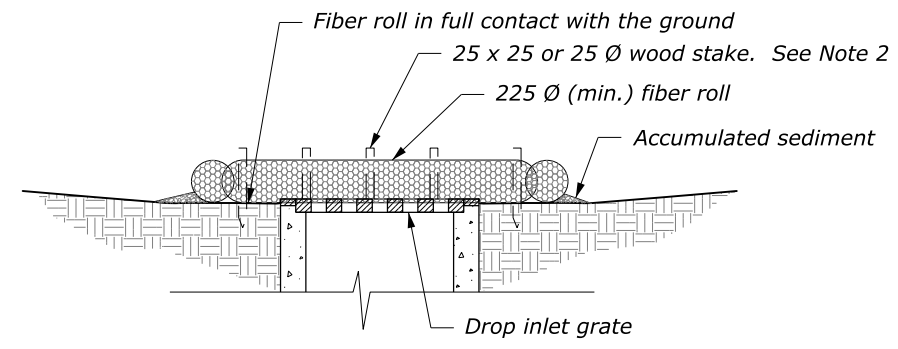

SECTION A-A

**FIBER ROLL
DROP INLET PROTECTION (TYPE A)**

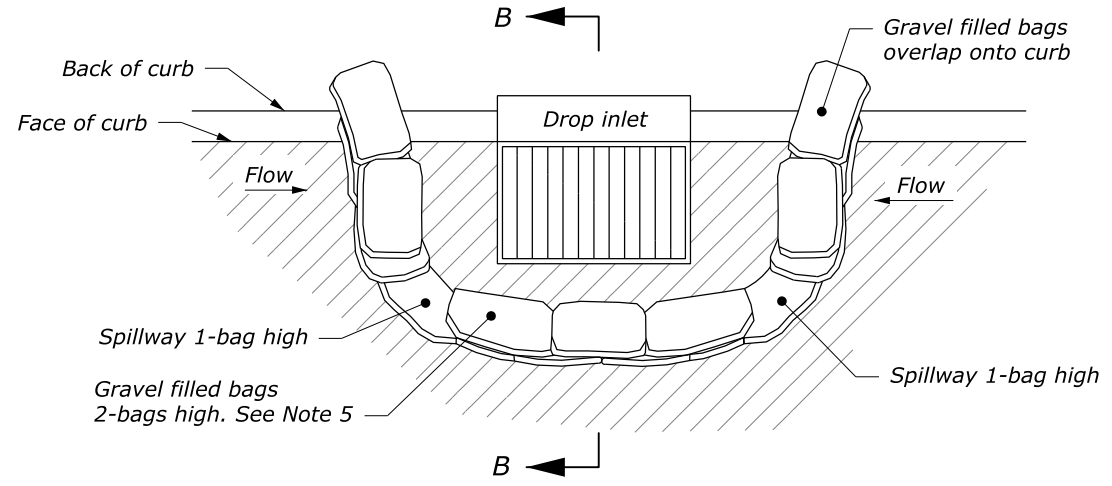

PLAN VIEW - INLET AT SAG

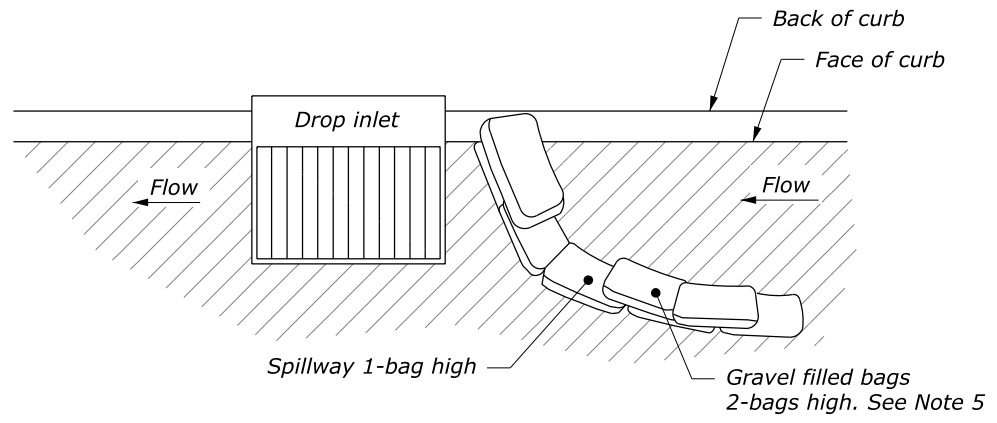

PLAN VIEW - INLET ON GRADE

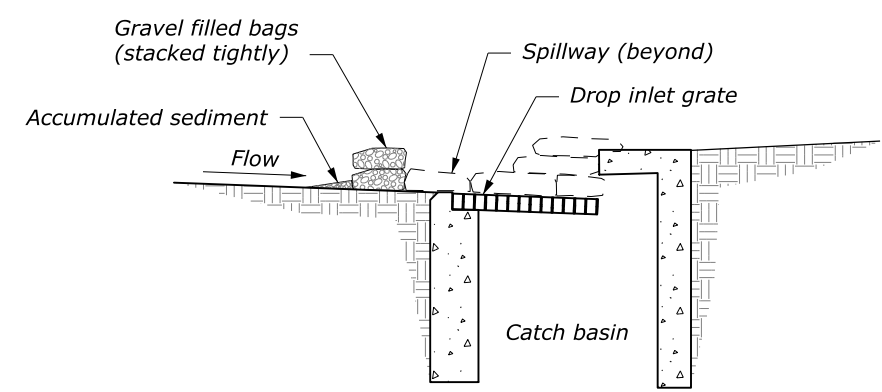

SECTION B-B

**GRAVEL BAG BERM
DROP INLET PROTECTION (TYPE B)**

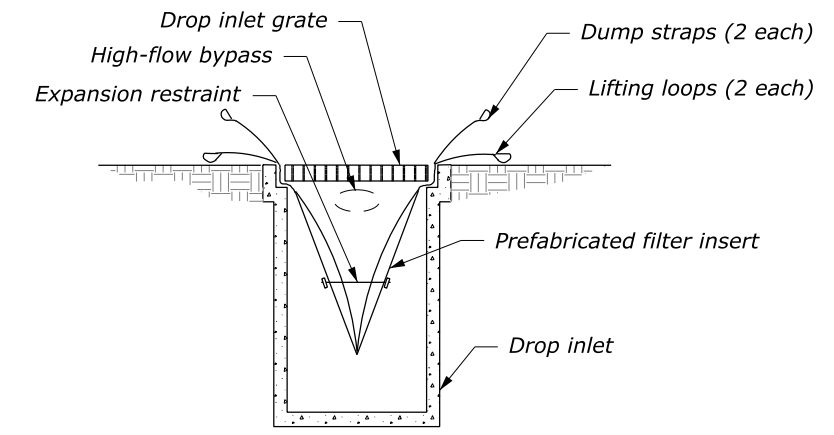

**PREFABRICATED FILTER INSERT
DROP INLET PROTECTION (TYPE C)**

See Note 6

NO SCALE

U.S. DEPARTMENT OF TRANSPORTATION FEDERAL HIGHWAY ADMINISTRATION WESTERN FEDERAL LANDS HIGHWAY DIVISION	
METRIC DETAIL	
TEMPORARY INLET PROTECTION	
Sheet 1 of 2	
DETAIL APPROVED FOR USE --/----	DETAIL
REVISED: 7/2016	MW157-2

NOTE:

1. Inlet protection device (type E) may consist of continuous filter tubing filled with gravel or other prefabricated filter material. Install device according to manufacturer's recommendations.
2. Vary dimensions to fit field conditions.
3. Dimensions without units are millimeters.

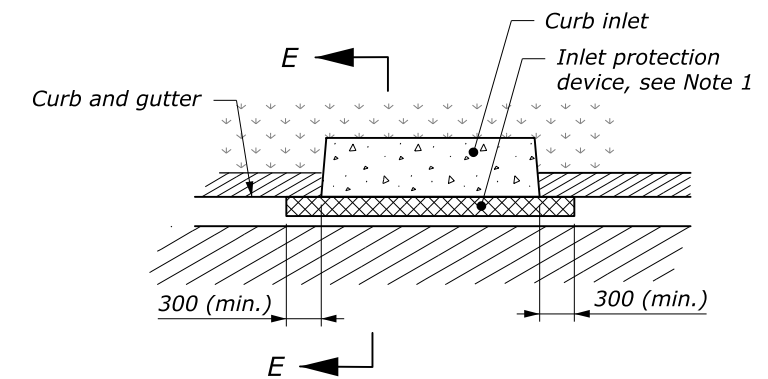
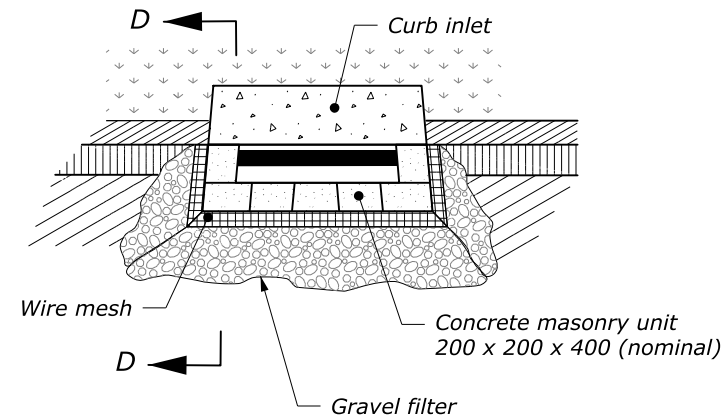
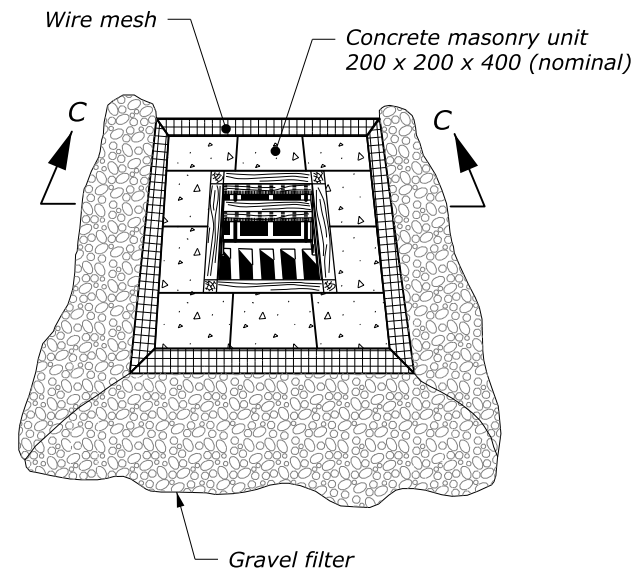

PLAN

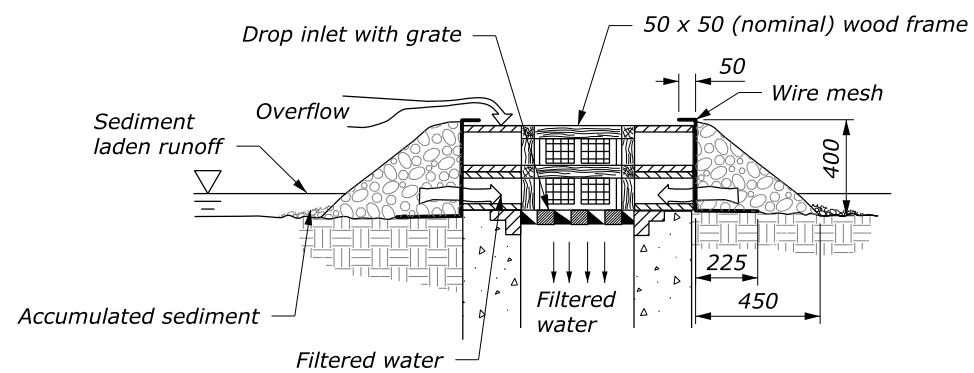

SECTION C-C

**BLOCK AND GRAVEL
DROP INLET PROTECTION (TYPE D1)**

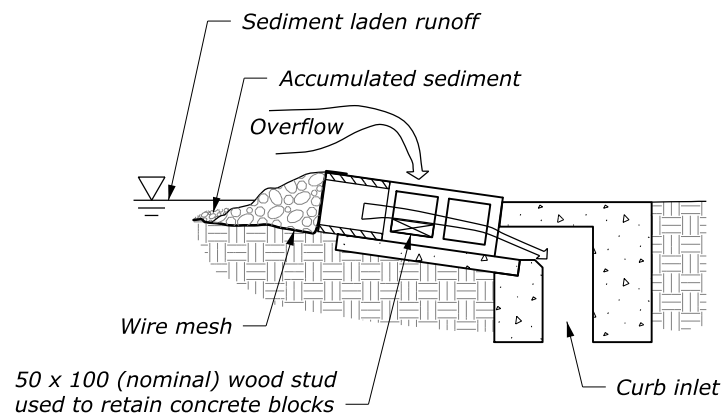

SECTION D-D

**BLOCK AND GRAVEL
CURB INLET PROTECTION (TYPE D2)**

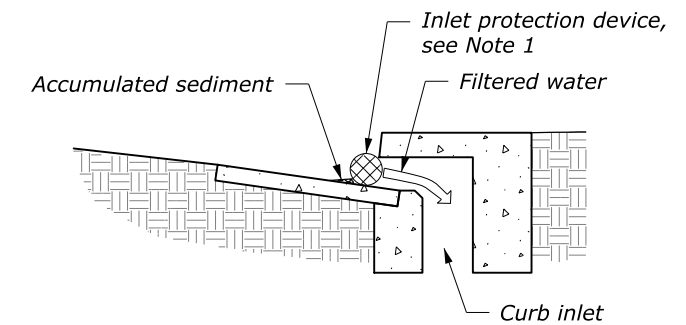

SECTION E-E

**INLET PROTECTION DEVICE
CURB INLET PROTECTION (TYPE E)**

NO SCALE

U.S. DEPARTMENT OF TRANSPORTATION FEDERAL HIGHWAY ADMINISTRATION WESTERN FEDERAL LANDS HIGHWAY DIVISION	
METRIC DETAIL	
TEMPORARY INLET PROTECTION	
Sheet 2 of 2	
DETAIL APPROVED FOR USE --/----	DETAIL
REVISED: 7/2016	MW157-2