

NOTE:

1. Locate bags in level areas (less than 5% grade). When level areas are not available, place geotextile and coarse aggregate to level the bags.
2. Locate bags in approved areas. Discharge onto stable, erosion resistant areas.
3. Locate bags in areas accessible by equipment for maintenance and removal.
4. Insert a maximum of one hose in each bag at any given time.
5. Replace bags when 50% of the sediment capacity has been reached and/or when there is a failure. Have spare bags on site for replacement.
6. Do not cut or empty filter bag onsite.
7. Do not permit discharge from the bags to drain back into work or access areas of the project.

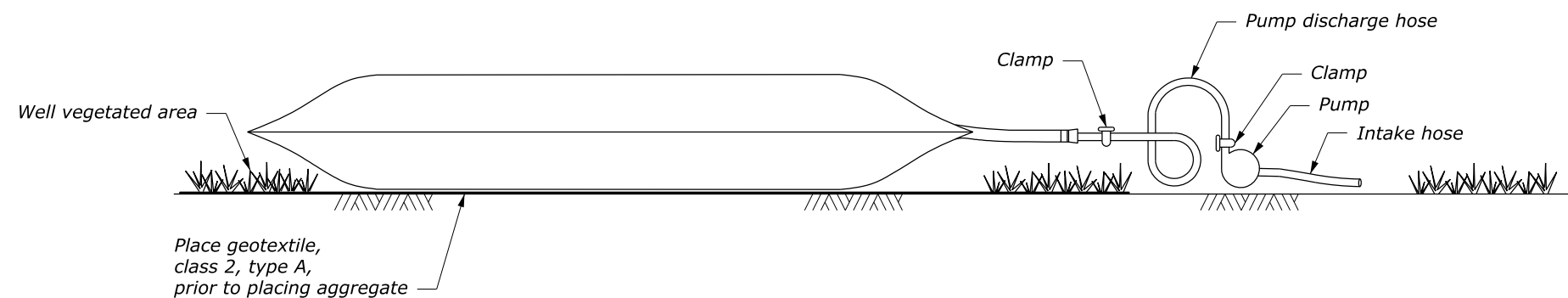

NO SCALE

U.S. DEPARTMENT OF TRANSPORTATION FEDERAL HIGHWAY ADMINISTRATION WESTERN FEDERAL LANDS HIGHWAY DIVISION	
METRIC DETAIL	
SEDIMENT FILTER BAG	
DETAIL APPROVED FOR USE --/----	DETAIL
REVISED: 10/2016	MW157-18