

NOTE:

1. Repair all rills or gullies and properly compact prior to installation.
2. Install check dams in ditches perpendicular to the flowline.
3. Adjust check dam spacing based on site-specific conditions.

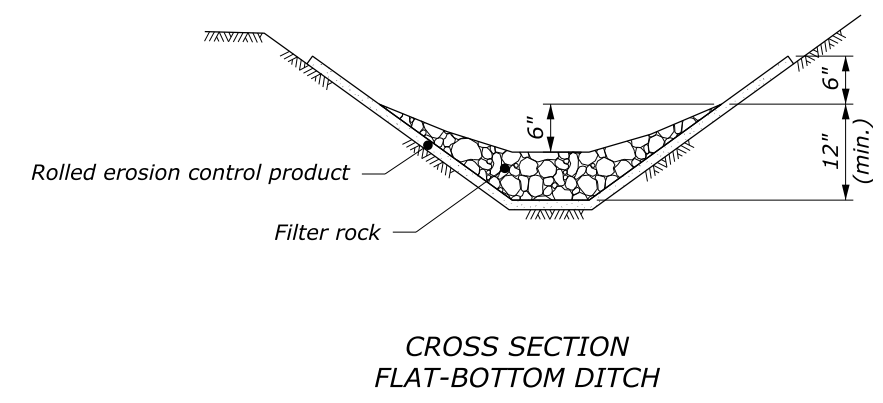
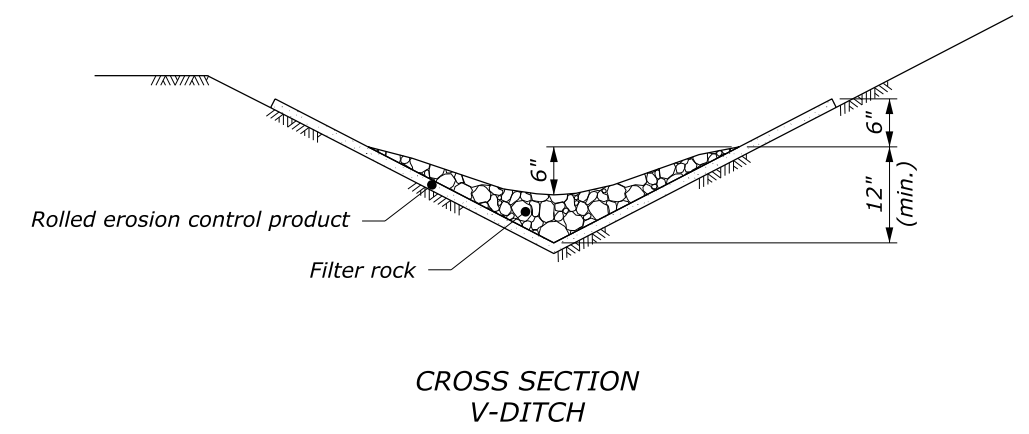
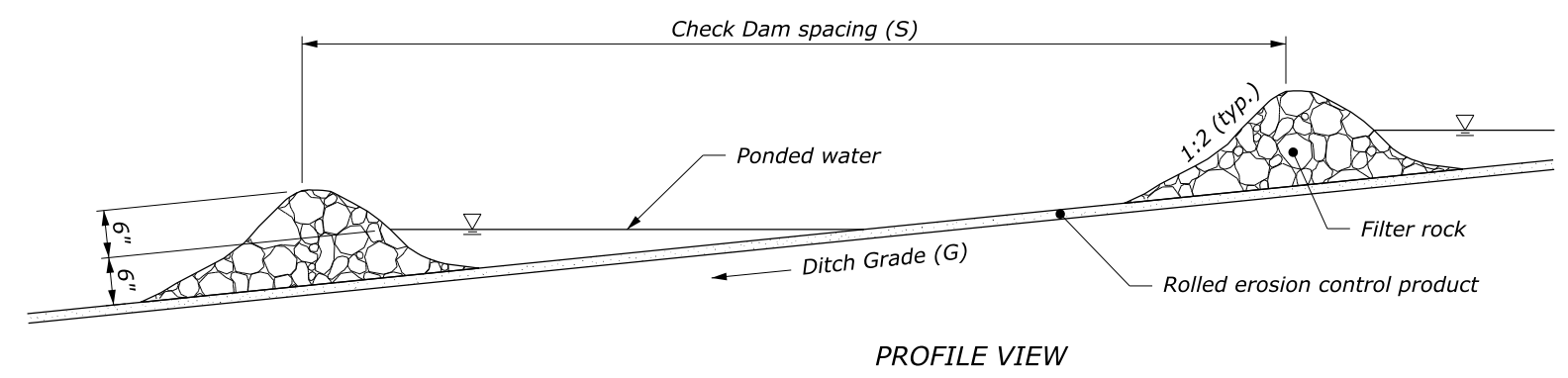

FILTER ROCK CHECK DAM SPACING (See Note 3)	
DITCH GRADE (G)	MAX. CHECK DAM SPACING (S) (FT)
7%	40
8% and 9%	30
≥10%	20

FILTER ROCK CHECK DAM WITH ROLLED EROSION CONTROL PRODUCT

NO SCALE

U.S. DEPARTMENT OF TRANSPORTATION FEDERAL HIGHWAY ADMINISTRATION WESTERN FEDERAL LANDS HIGHWAY DIVISION	
U.S. CUSTOMARY DETAIL	
CHECK DAM WITH ROLLED EROSION CONTROL PRODUCT	
DETAIL APPROVED FOR USE --/----	DETAIL
REVISED: 7/2016	W157-16