

SPILLWAY ASSEMBLY WITH SURFACE DOWN DRAIN

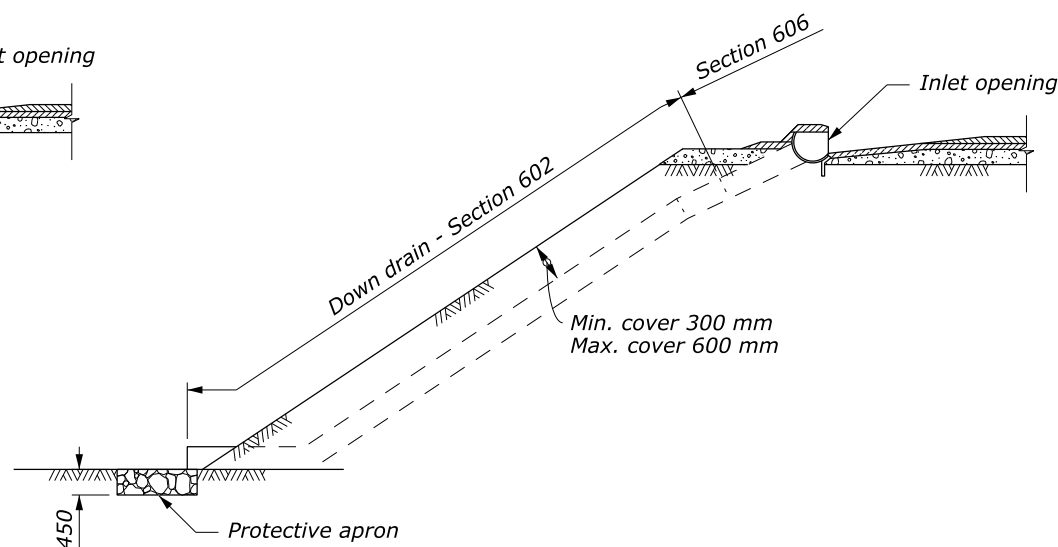

SPILLWAY ASSEMBLY WITH BURIED DOWN DRAIN

NOTE:

1. Fabricate half-round pipe, outlet pipe, and curtain wall for spillway assembly from 1.6 mm galvanized steel or 1.5 mm aluminum. Fabricate top plate and end plate from 4.6 mm flat steel or 5.0 mm aluminum plate.
2. Make all coupling band connections watertight by placing a 5 mm bead of approved caulking under each half of the band before tightening.
3. Install pipe anchor assemblies at 3,000 mm ± spacing on down drain installed above ground.
4. Use type 2 spillway assembly inlets where profile grades are greater than 2%. Use type 1 on grades 2% or flatter.
5. Place class 2 riprap conforming to Section 251 for protective apron.
6. Approved alternate designs may be used.
7. See Detail WM606-14 for Pipe Anchor Assembly Detail.
8. Furnish hardware in the metric sizes shown. Equivalent US Customary sizes may be used when metric sizes are not available.
9. Dimensions without units are millimeters.

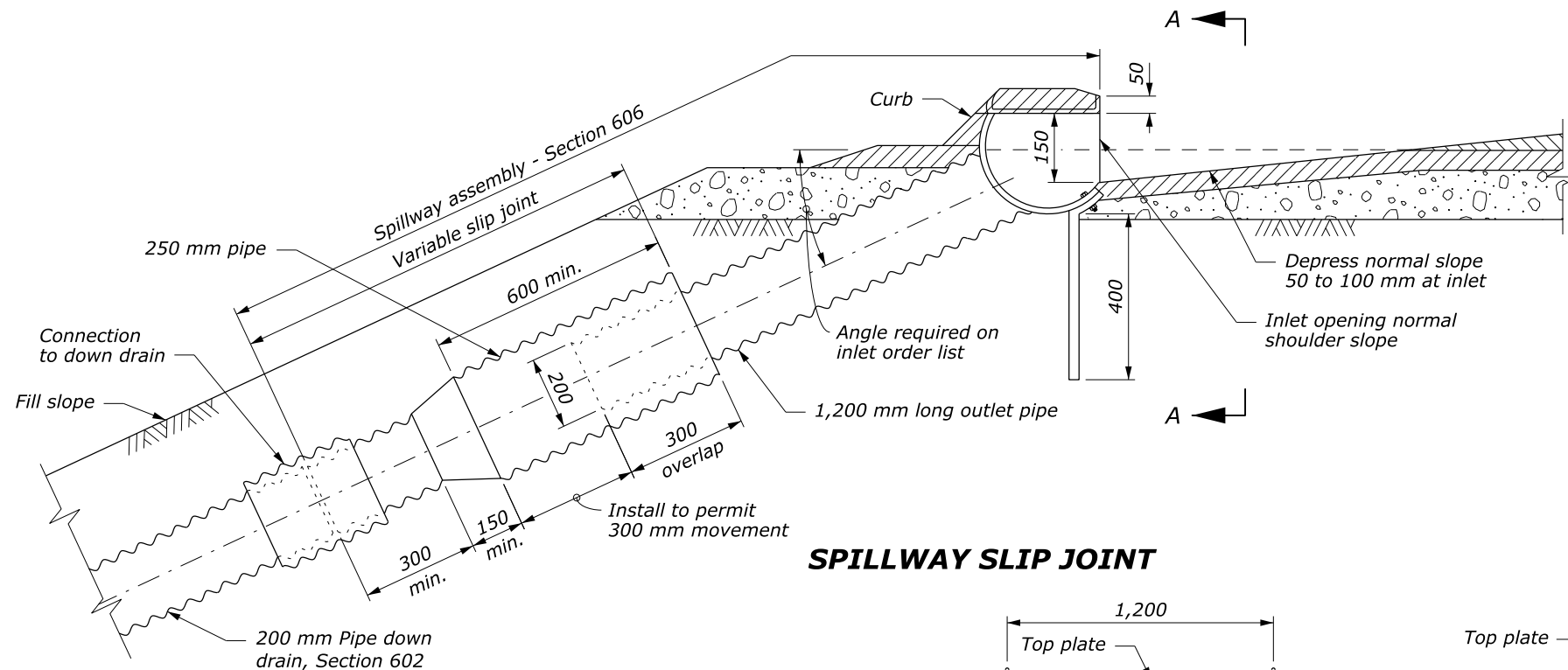

SPILLWAY SLIP JOINT

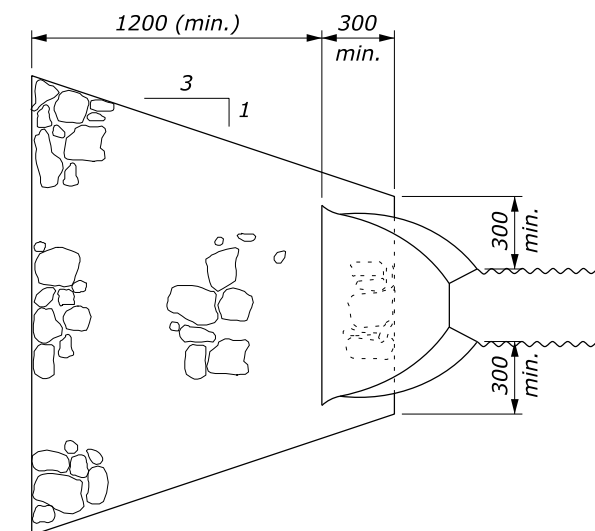

PLAN

PROTECTIVE APRON

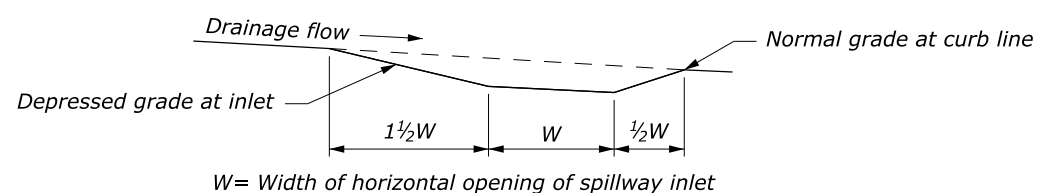

SCHEMATIC PROFILE OF INLET BASIN

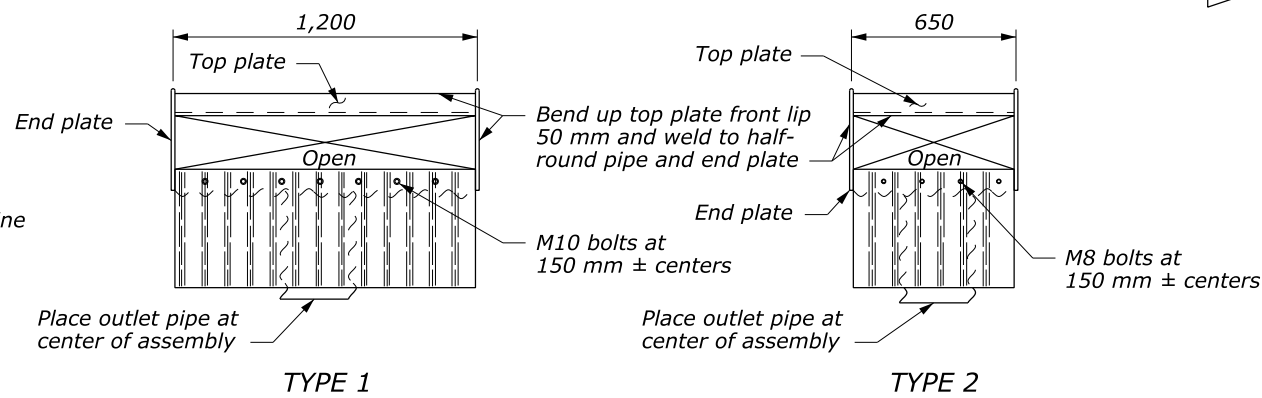

**SECTION A-A
SPILLWAY ASSEMBLY INLETS**

NO SCALE

U.S. DEPARTMENT OF TRANSPORTATION FEDERAL HIGHWAY ADMINISTRATION WESTERN FEDERAL LANDS HIGHWAY DIVISION	
METRIC DETAIL	
CORRUGATED METAL SPILLWAYS AND INLETS	
DETAIL APPROVED FOR USE 10/2009	DETAIL
REVISED:	WM606-13