

**W BEAM RAIL**

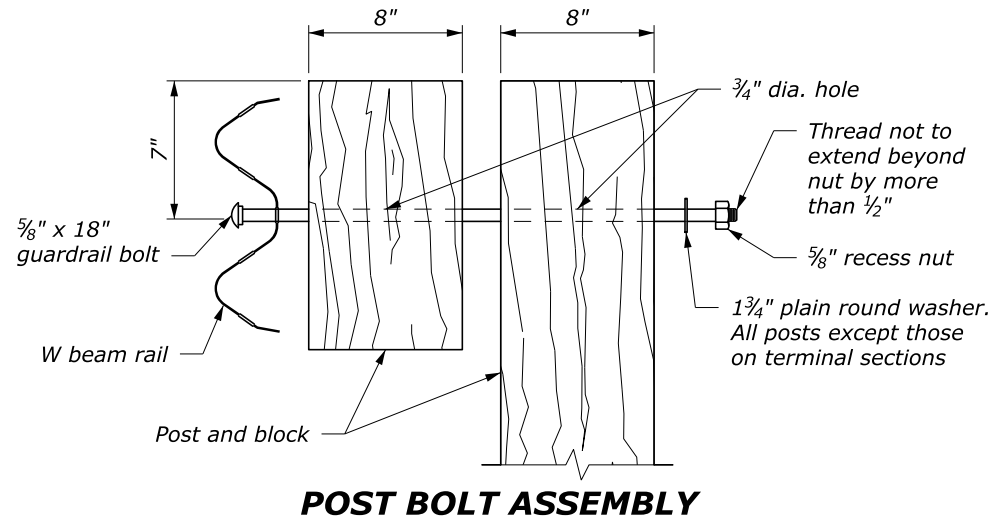

- NOTE:**
1. When encountering impenetrable material, see ET Details 617-13 or 617-24.
  2. See Special Contract Requirements when 7 foot or longer posts are specified.
  3. See Special Contract Requirements when the alternative hole arrangement is specified.
  4. Install reflector tab between post bolt and rail, every fourth post. Alternate reflector tab shapes are acceptable.
  5. Dimensional tolerances not shown or implied are intended to be those consistent with the proper functioning of the part, including its appearance, and accepted manufacturing practices.

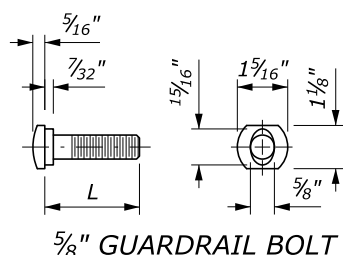
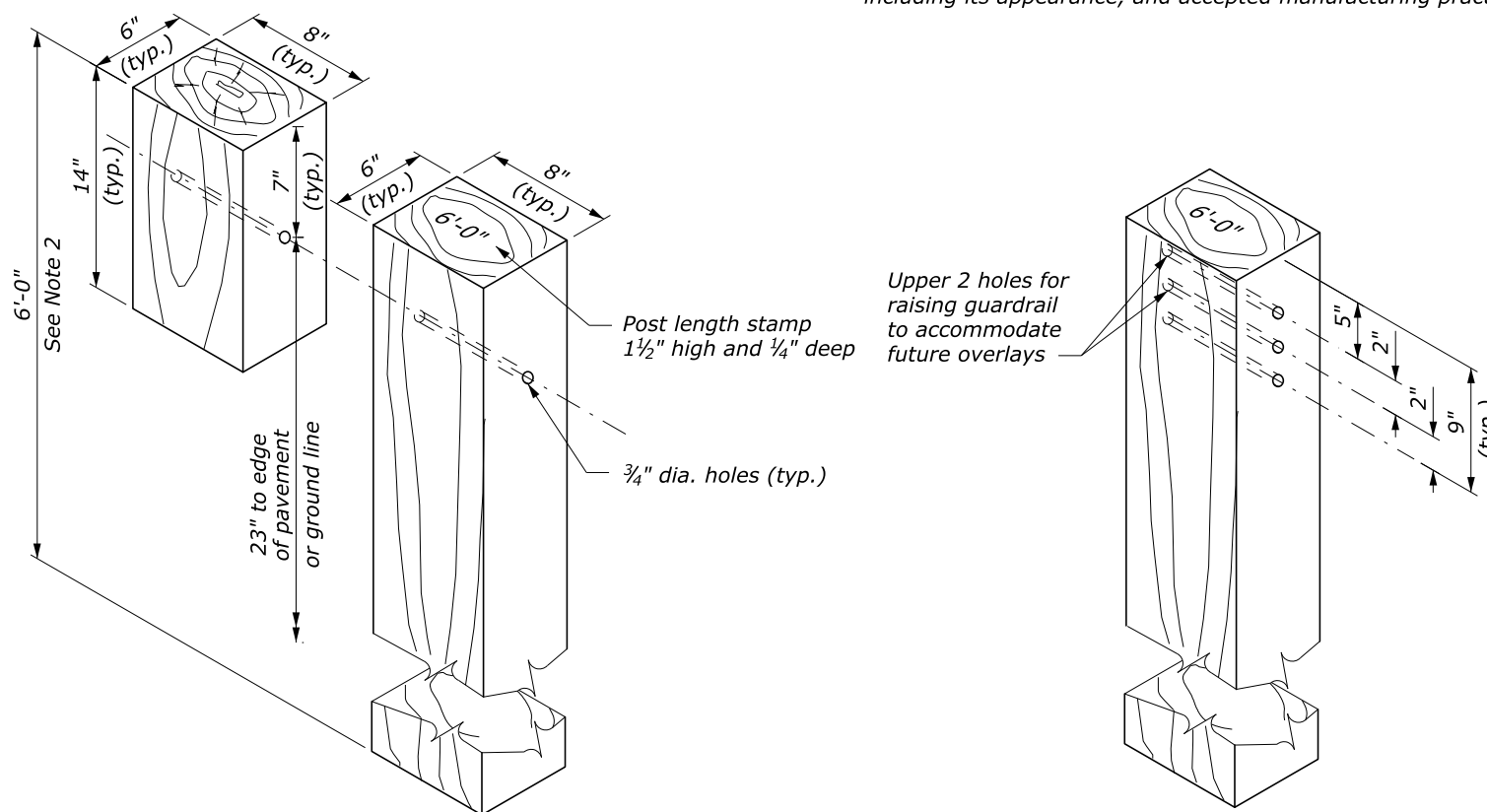

L	Thread Length
1 1/4"	1 1/8" minimum
2"	1 3/4" minimum
10"	4" minimum
18"	4" minimum
25"	4" minimum

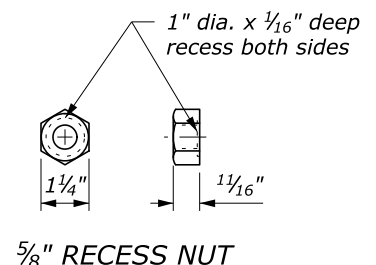

**GUARDRAIL BOLT AND RECESS NUT**

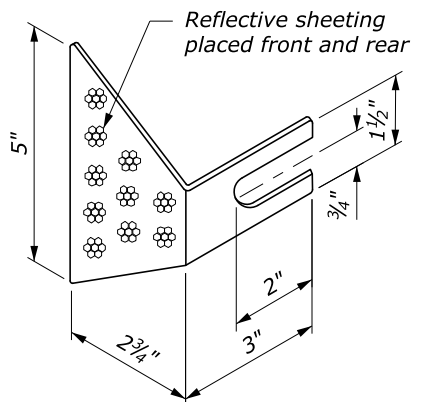
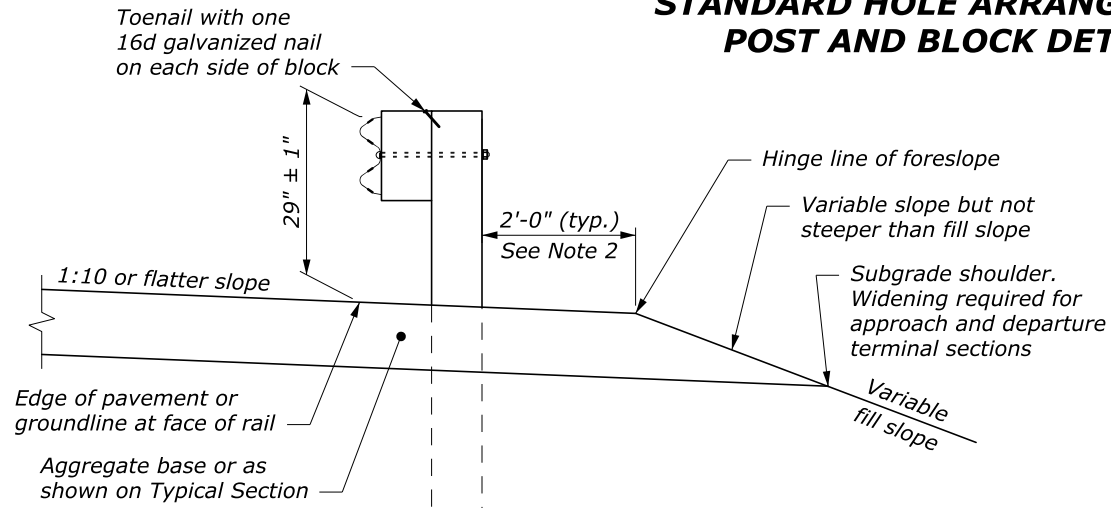
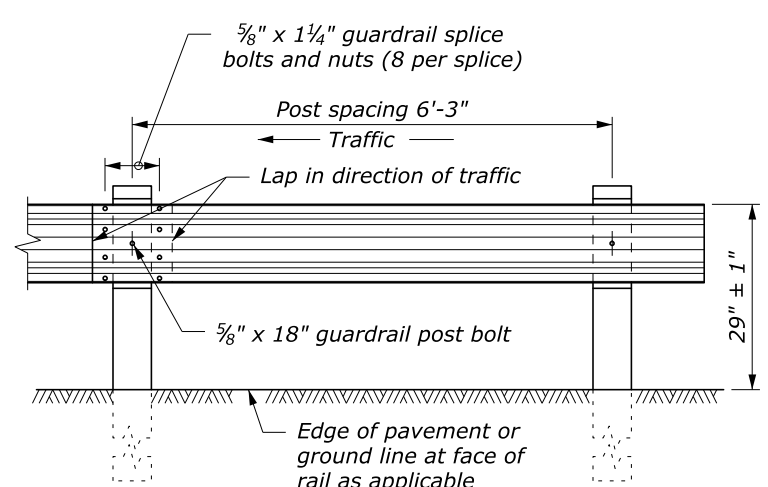

NO SCALE

U.S. DEPARTMENT OF TRANSPORTATION  
 FEDERAL HIGHWAY ADMINISTRATION  
 EASTERN FEDERAL LANDS HIGHWAY DIVISION

U.S. CUSTOMARY DETAIL

**G4 W-BEAM GUARDRAIL WOOD POSTS**

STANDARD APPROVED FOR USE 1/1994  
 REVISIONS: 4/1994 6/2005 10/2013 4/2016

DETAIL  
 ET 617-10

29-Apr-2016 10:29 AM M:\Standards\_and\_Details\EF\HLD\_Detail\Drawings\FP-4\Updates ET Details 4-2016\Std617-10.dgn