

POLYETHYLENE (PE) PLASTIC ROUND PIPE CULVERT

FILL HEIGHT TABLE AND MINIMUM CELL CLASSIFICATION NUMBER PER ASTM D 3350

SMOOTH WALL (SOLID WALL)								CORRUGATED			RIBBED			
PIPE SIZE DIAMETER INCHES	MINIMUM COVER INCHES	CELL CLASSIFICATION NUMBER 335434C						PIPE SIZE DIAMETER INCHES	MINIMUM COVER INCHES	CELL CLASS. NO. 435400C	PIPE SIZE DIAMETER INCHES	MINIMUM COVER INCHES	CELL CLASS. NO. 334433C	CELL CLASS. NO. 335434C
		MINIMUM WALL THICKNESS (INCHES)												
		0.607	0.857	0.923	1.154	1.385	1.292						1.477	MAXIMUM FILL HEIGHT (FEET)
12	12	57						12	12	10	18	12	18	24
18	12		52					15	12	10	24	12	22	28
24	12			38				18	12	10	30	12	22	28
30	12				38			24	12	10	36	12	25	31
36	12					38		30	12	10	42	12	21	27
42	12						27	36	12	10	48	12	21	26
48	12						27							

NOTE:

- When directed, camber pipe culverts upward from a chord through the inlet and outlet inverts an ordinate amount equal to 1% of the pipe length. Develop camber on a parabolic curve. If the midpoint elevation on the parabolic curve as designed exceeds the elevation of the inlet invert, reduce the amount of camber or increase the pipe culvert gradient.
- Measure minimum cover from the top of the pipe culvert to the subgrade for flexible pavements, and to the top of the pavement for rigid pavements. Measure maximum fill height from the top of the pipe to the top of the pavement for both flexible and rigid pavement.

POLYVINYL CHLORIDE (PVC) PLASTIC ROUND PIPE CULVERT

FILL HEIGHT TABLE AND MINIMUM CELL CLASSIFICATION NUMBER PER ASTM D 1784

SMOOTH WALL (SOLID WALL)						RIBBED			
PIPE SIZE DIAMETER INCHES	MINIMUM COVER INCHES	CELL CLASS. NO. 12454		CELL CLASS. NO. 12364		PIPE SIZE DIAMETER INCHES	MINIMUM COVER INCHES	CELL CLASS. NO. 12454C	CELL CLASS. NO. 12364C
		MINIMUM WALL THICKNESS (INCHES)							
		0.358	0.438	0.358	0.438			MAXIMUM FILL HEIGHT (FEET)	
12	12	65		69		12	12	37	26
15	12		62		66	15	12	32	22
						18	12	33	23
						24	12	29	21
						30	12	28	20
						36	12	27	19
						42	12	26	18
						48	12	24	17

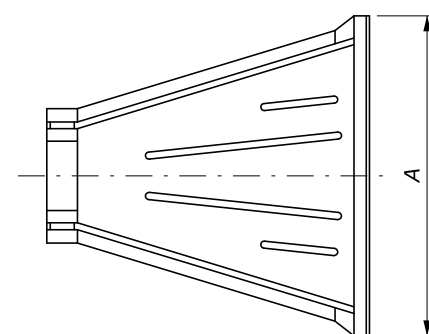

TOP

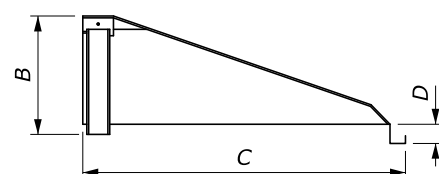

SIDE

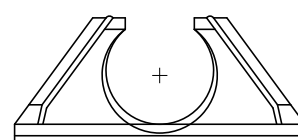

FRONT

PLASTIC PIPE END SECTION

END SECTION DIMENSIONS

PIPE SIZE DIAMETER INCHES	DIMENSIONS INCHES			
	A	B	C	D
12	42	14.5	33	6
15	46	24.5	45.5	6
18	54	29	55	6
24	64	37	65	6
30	88	36	63.5	6
36	88	43	66.5	6

NO SCALE

U.S. DEPARTMENT OF TRANSPORTATION FEDERAL HIGHWAY ADMINISTRATION EASTERN FEDERAL LANDS HIGHWAY DIVISION	
U.S. CUSTOMARY DETAIL	
PLASTIC PIPE CULVERT	
STANDARD APPROVED FOR USE 12/1993 REVISED: 4/1994 6/2005 2/2009 3/2016	DETAIL ET 602-5