

PLAN

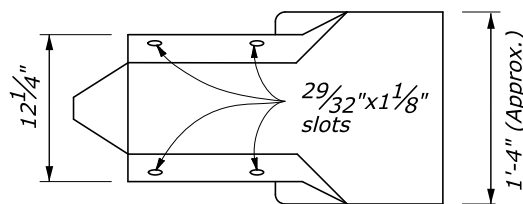

ELEVATION

*This dimension is 7 1/2" in RE-7-79. If the same dimension is used in this part, it will give an acceptable overall length (**) of approximately 2'-1 1/2" .

**ROUND END SECTION
ARTBA RE-6-79**

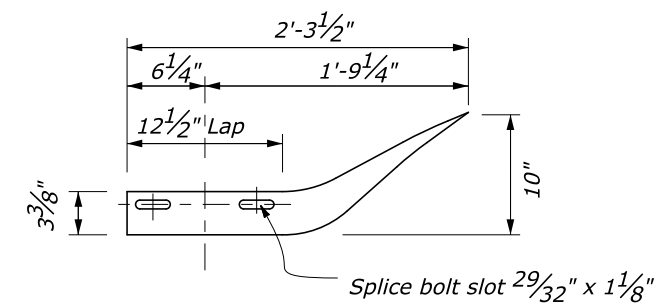

PLAN

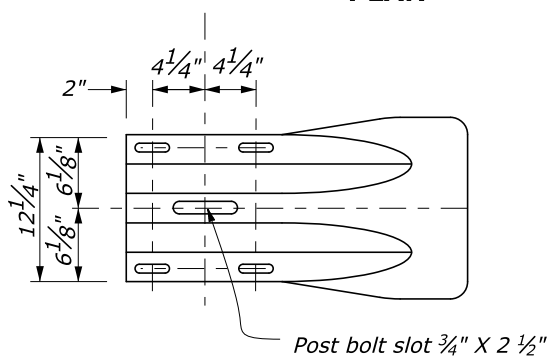

ELEVATION

**FLARED END SECTION
ARTBA RE-5-76**

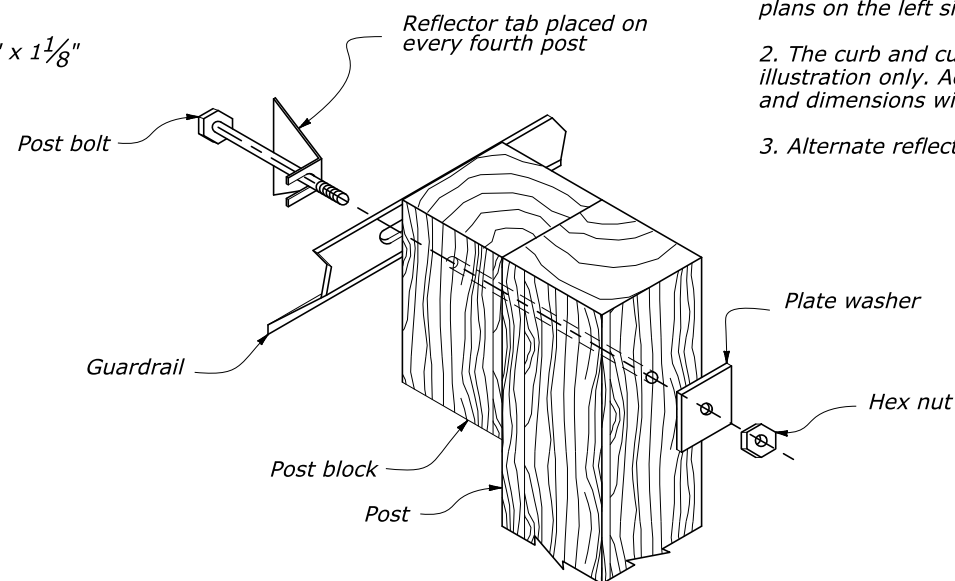

ASSEMBLY DETAIL

NOTES:

1. Rounded or flared end sections are acceptable alternates to buffered end sections and type 1 end sections on terminal sections at the trailing ends of guardrail runs on the right side of multilane roadways and where shown on the plans on the left side of multilane roadways.
2. The curb and curb and gutter shape are shown for illustration only. Actual curb and curb and gutter shapes and dimensions will show on the plans.
3. Alternate reflector tab shapes are acceptable.

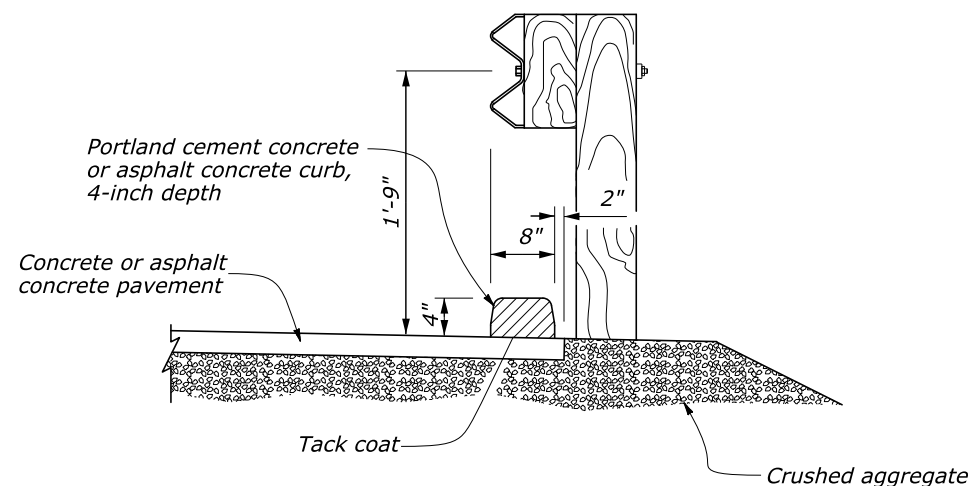

**PLACEMENT OF GUARDRAIL
AT CURB LOCATIONS**

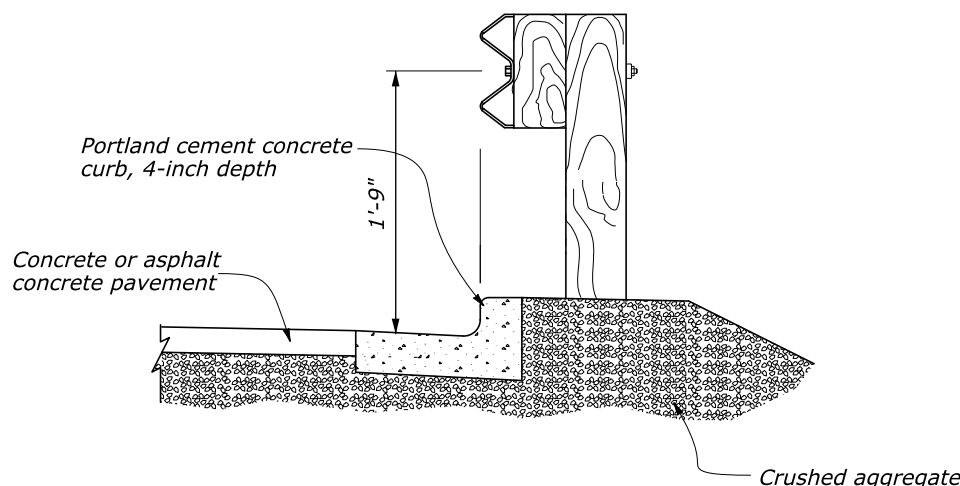

**PLACEMENT OF GUARDRAIL
AT CURB AND GUTTER LOCATIONS**

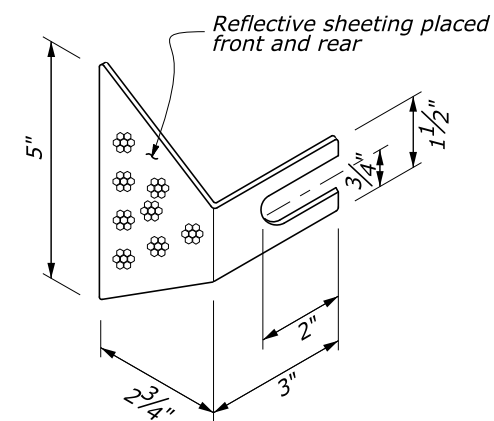

NO SCALE

U.S. DEPARTMENT OF TRANSPORTATION FEDERAL HIGHWAY ADMINISTRATION EASTERN FEDERAL LANDS HIGHWAY DIVISION U.S. CUSTOMARY DETAIL	
G4 W BEAM GUARDRAIL SUPPLEMENT INSTALLATION DETAILS	
DETAIL APPROVED FOR USE	DETAIL
APPROVED : MAY 2011 REVISED : SEPTEMBER 2014	E617-23