

16-INCH DEPTH
(MOUNTABLE)

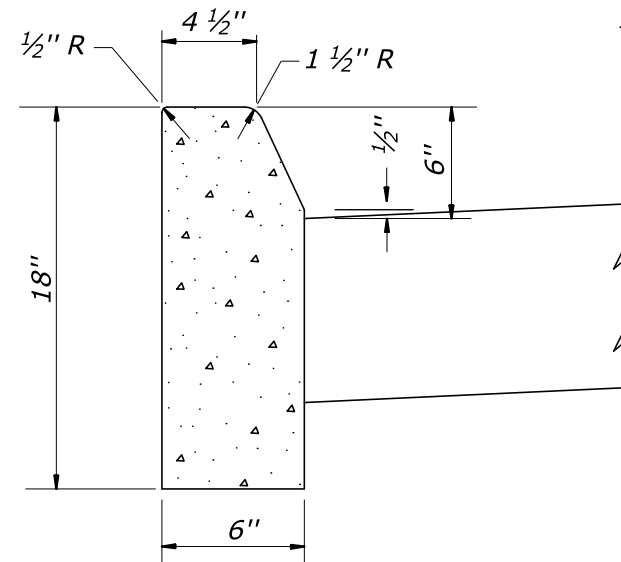

18-INCH DEPTH
(NON-MOUNTABLE)

Note:

1. Place 3 inches, minimum aggregate bed course under all curb and gutter.

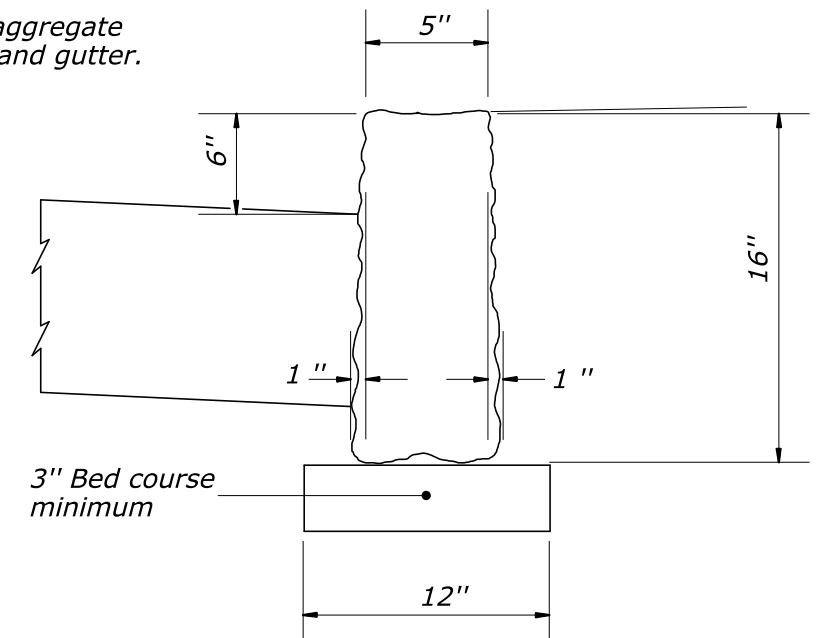

STONE CURB

16-INCH DEPTH
(NON-MOUNTABLE)

PORTLAND CEMENT CONCRETE CURB

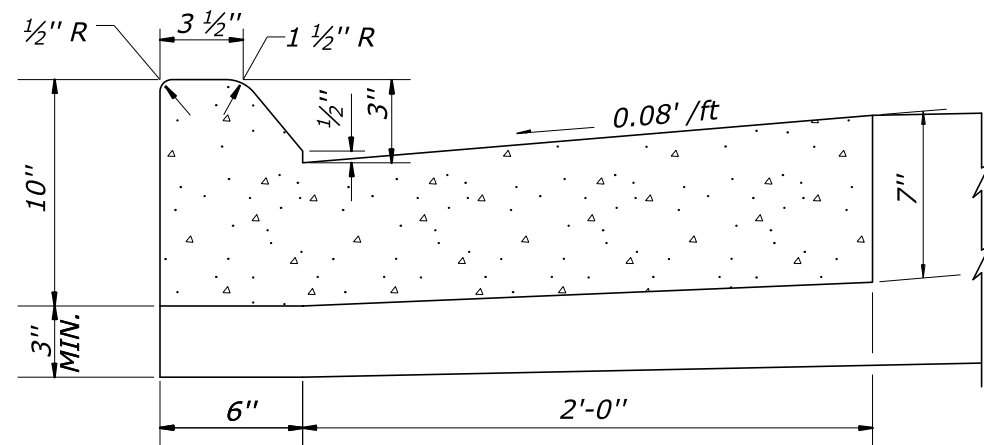

10-INCH DEPTH
(MOUNTABLE)

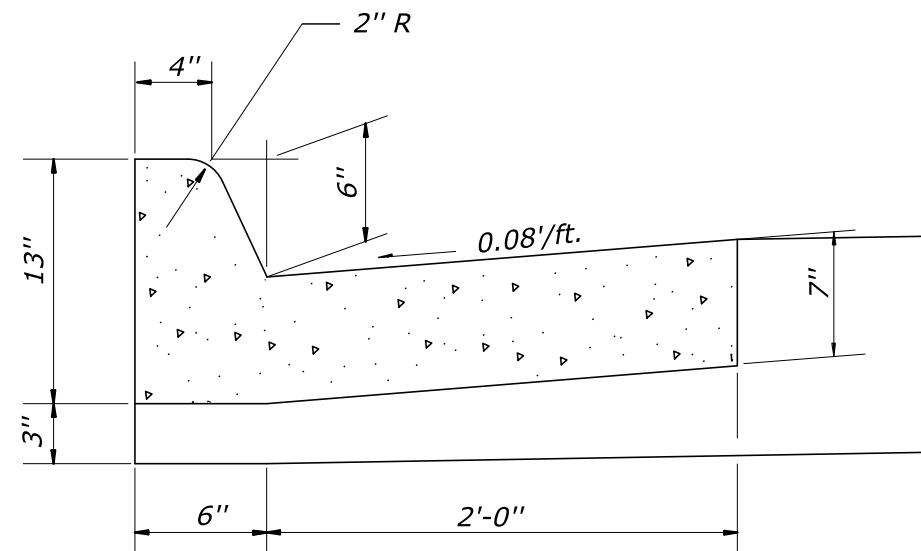

13-INCH DEPTH
(NON-MOUNTABLE)

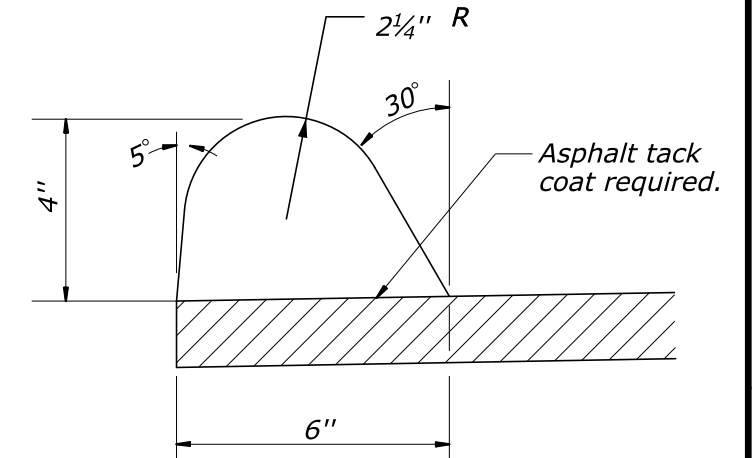

ASPHALT CONCRETE CURB

4-INCH DEPTH
(NON-MOUNTABLE)

Asphalt tack coat may be rapid curing liquid asphalt or emulsified asphalt.

PORTLAND CEMENT CONCRETE CURB AND GUTTER

NO SCALE

U.S. DEPARTMENT OF TRANSPORTATION FEDERAL HIGHWAY ADMINISTRATION EASTERN FEDERAL LANDS HIGHWAY DIVISION	
U.S. CUSTOMARY DETAIL	
CURBS	
DETAIL APPROVED FOR USE	DETAIL
APPROVED: MAY 2011	
REVISED: SEPTEMBER 2014	E609-01