

NOTE:  
 1. Location of pipe underdrains may be adjusted by the CO.  
 2. Minimum grade of underdrain is 0.5%.

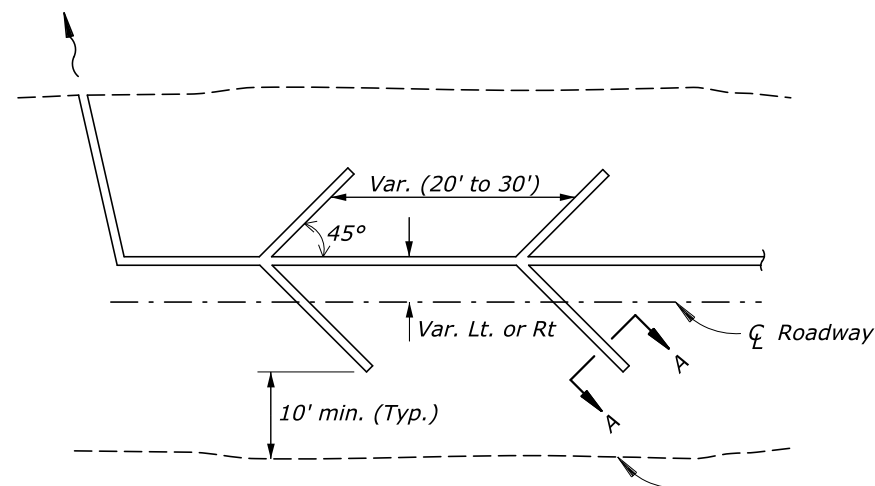

**HERRINGBONE DRAINAGE PATTERN  
(PARALLEL TO  $\zeta$ )**

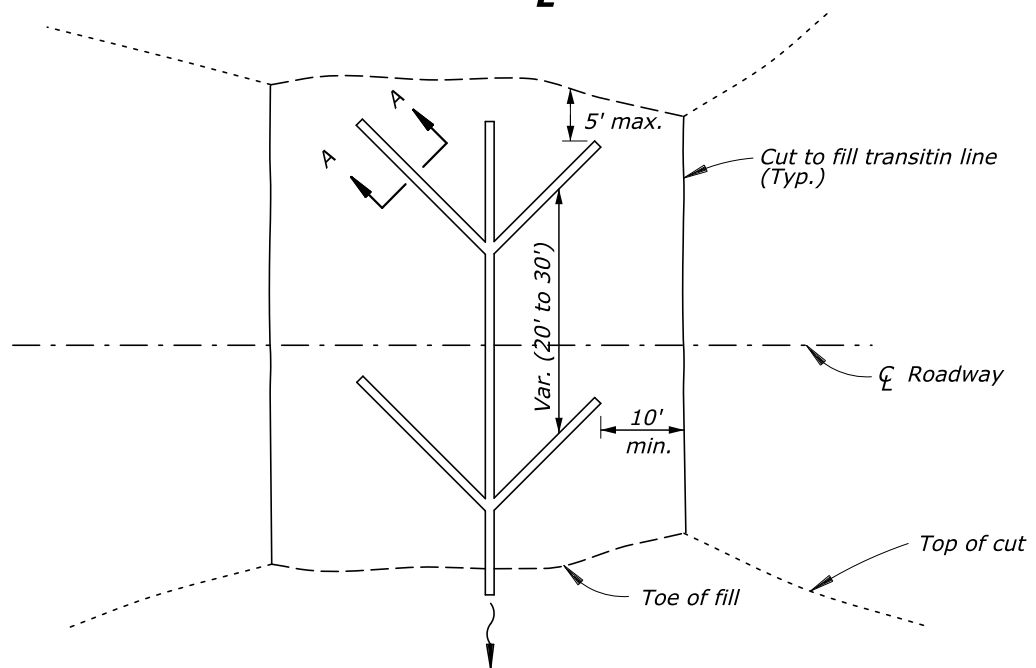

**HERRINGBONE DRAINAGE PATTERN  
(PREPENDICULAR TO  $\zeta$ )**

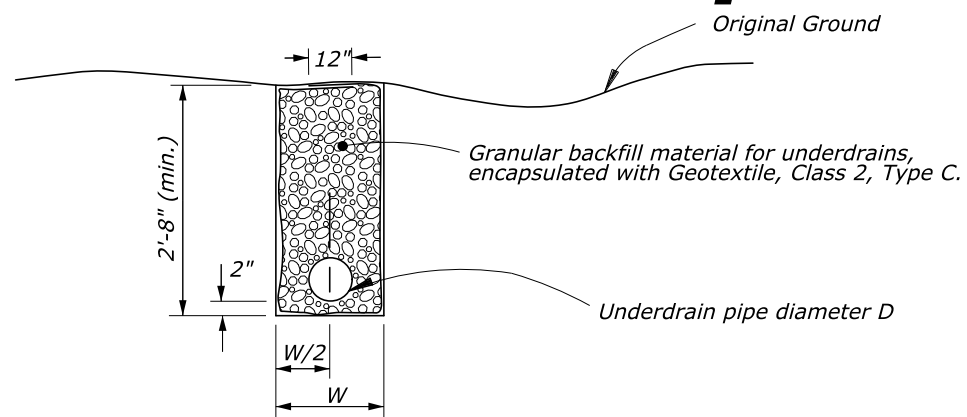

**SECTION A-A**

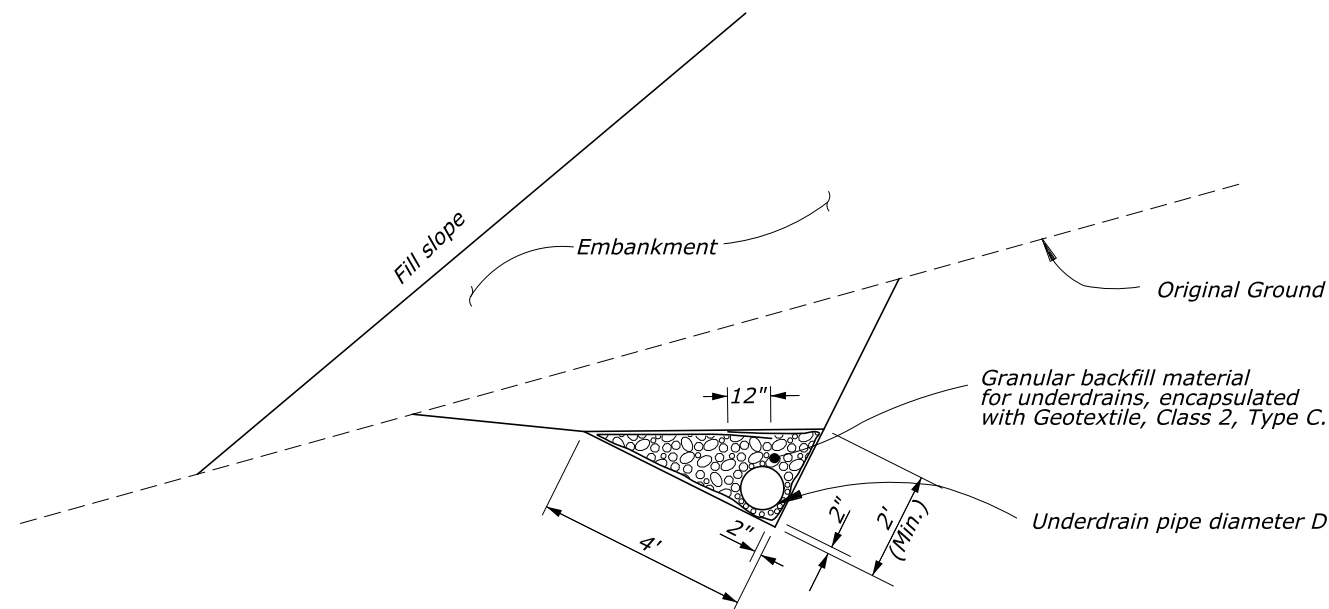
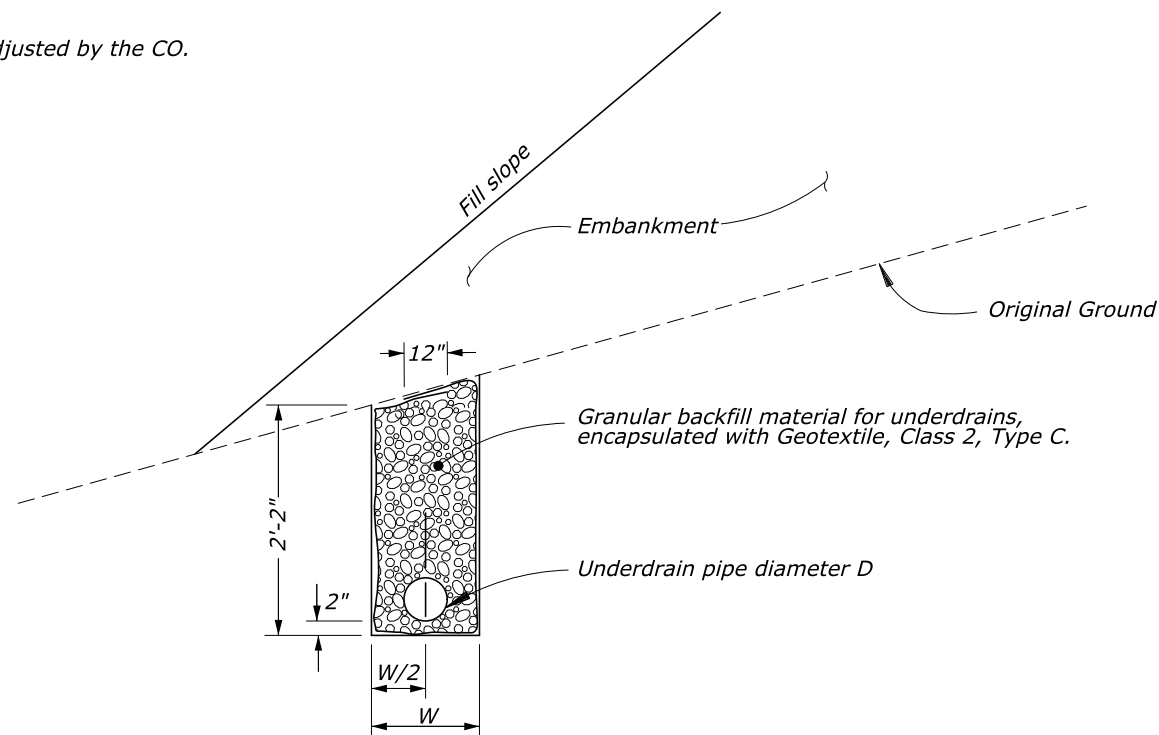

DIAMETER (D)	WIDTH (W)
4"	12"
6"	15"

01-Dec-2014 01:51 PM \$TIME\$ H:\Team\_Folders\VIDU6\FP\_14\_Detail\_Review\ALL\_FPH\_D01\60502\_detail.dgn

U.S. DEPARTMENT OF TRANSPORTATION FEDERAL HIGHWAY ADMINISTRATION EASTERN FEDERAL LANDS HIGHWAY DIVISION	
U.S. CUSTOMARY DETAIL	
<b>UNDERDRAIN, FOR FILL SLOPES</b>	
DETAIL APPROVED FOR USE	DETAIL
APPROVED: MAY 2011 REVISED: SEPTEMBER 2014	E605-02