

9:44:01 AM N:\CFL-DPT\Drawings\FP-14\FP14_Details\C602-50.dgn 9/22/2014

NOTE:

1. Furnish metal pipe culvert, elbows, and coupling bands according to Section 602.
2. Furnish riprap for protective apron according to Section 251 & Detail C251-50.
3. Furnish hardware galvanized according to AASHTO M111M.
4. Place pipe anchor assemblies at approximately 20' intervals along rundown portion of drain pipe.
5. Other suitable pipe anchor assemblies may be used upon approval in writing by the CO.
6. The use of the hugger band is restricted to welded spiral pipe with annular end corrugations or riveted annularly corrugated pipe.
7. Metal pipe shown is typical. Steel, aluminum, and concrete pipes as indicated on the drainage summary sheet, may be used.
8. Join concrete pipe according to Section 602 or other methods approved by the CO.
9. Use alternate A anchor assembly only with annular corrugations. May be placed on annular or preformed end coupling band if securely fastened on downstream side of joint. Alternate B anchor assembly to be fastened to pipe sections and not to band coupler used to join sections.
10. Use gaskets on all joints along the rundown portion of drain pipe.
11. Pipe anchor assemblies will be paid for under Section 606.

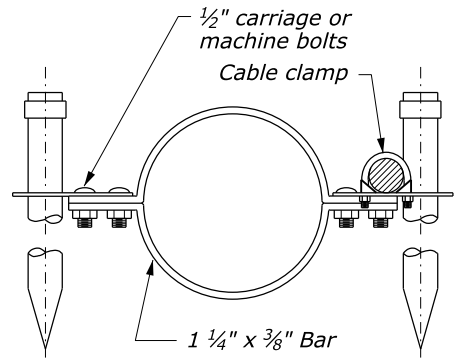
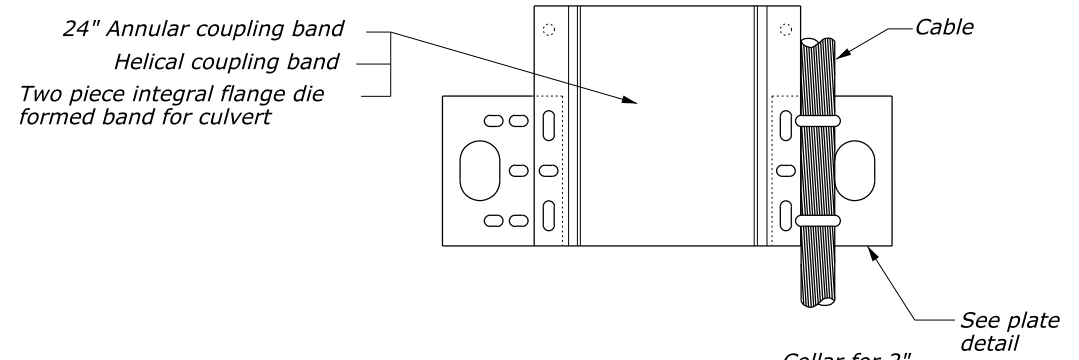
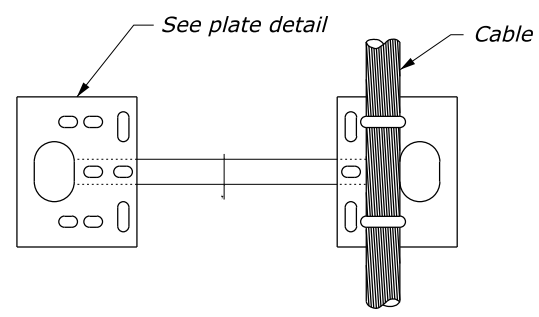
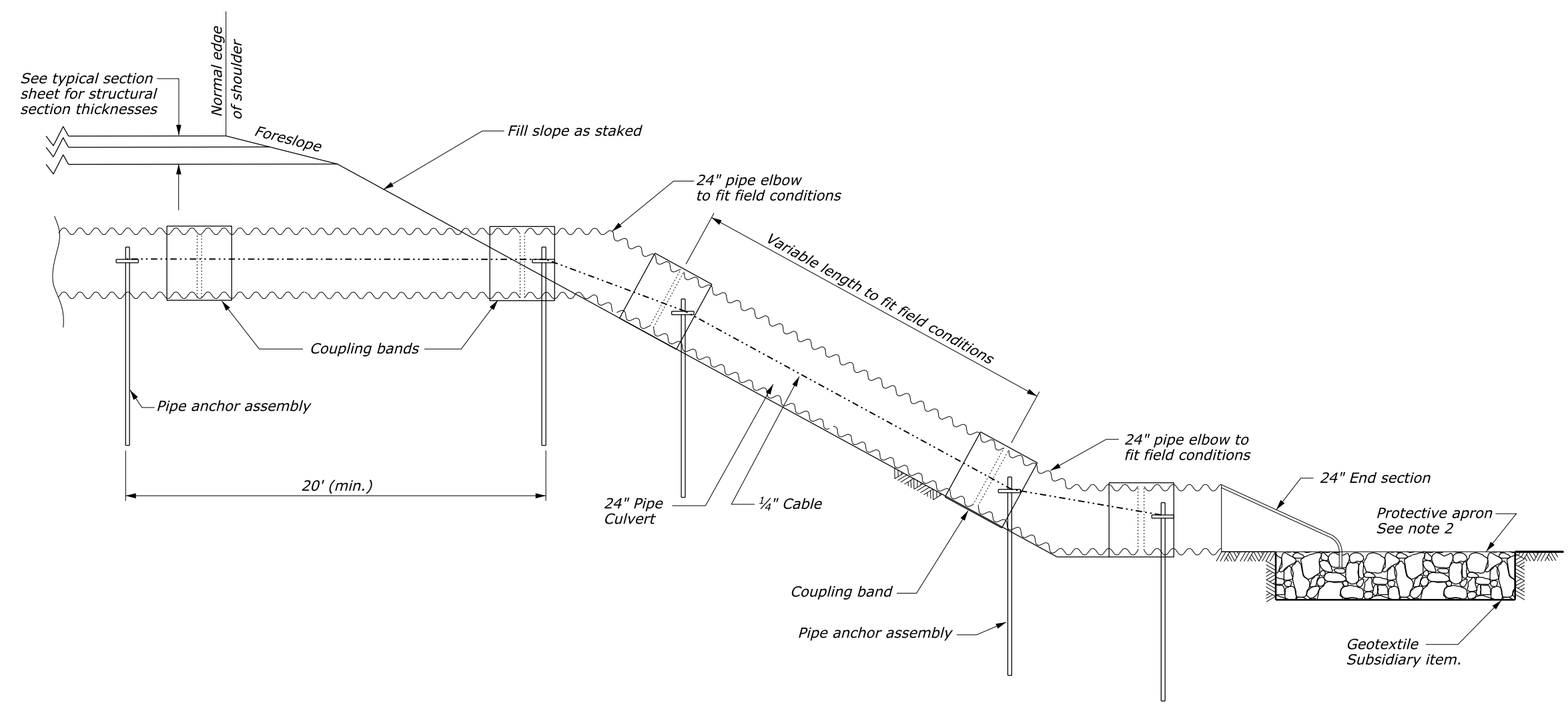

ALTERNATE A

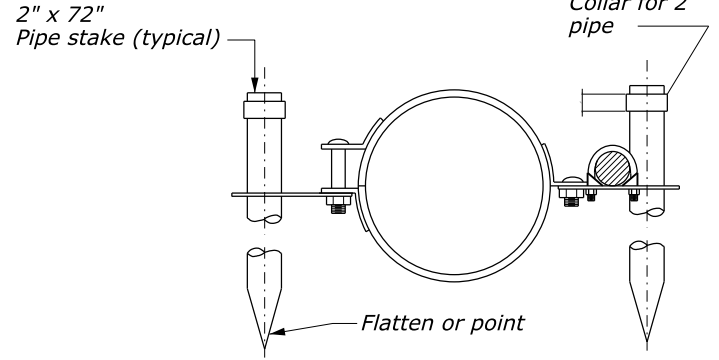

ALTERNATE B

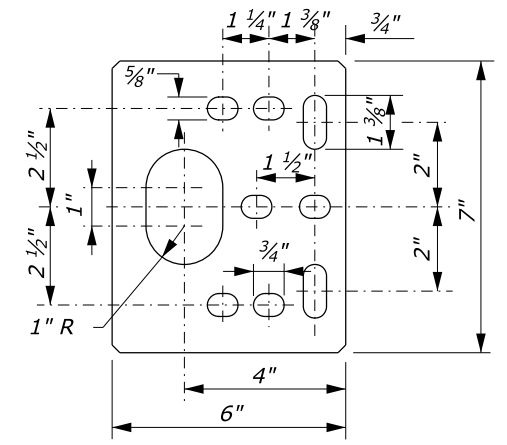

Material to be 1/4" plate galvanized after fabrication

PLATE DETAIL NO SCALE

PIPE ANCHOR ASSEMBLY DETAILS

U.S. DEPARTMENT OF TRANSPORTATION
 FEDERAL HIGHWAY ADMINISTRATION
 CENTRAL FEDERAL LANDS HIGHWAY DIVISION
 U.S. CUSTOMARY DETAIL
24" RUN DOWN AND PIPE ANCHOR ASSEMBLY
 DETAIL APPROVED FOR USE
 REVISIONS: 08/2006 08/2014
 DETAIL C602-50



NOTES TO THE DESIGNER

Last Updated: August 2014

General Information

N/A

Applicable SCRs

1. Section 251:

<http://www.cflhd.gov/resources/design/constructspecs/scr/fp14/documents/S251-14.docx>

Typical Pay Items Used

- 25101-2200 Placed riprap, method B, class 2 and/or
- 25101-2300 Placed riprap, method B, class 3 and/or
- 25101-2400 Placed riprap, method B, class 4

- 60201-0800 24-inch pipe culvert
- 60210-0800 End section for 24-inch pipe culvert
- 60212-0800 Elbow, 24-inch
- 60602-0700 Pipe anchor assembly, 24-inch

- Geotextile quantity is shown for information only

Updates

October 16, 2000

- Updated border to FLH Standard

February 28, 2005

- Updated to MicroStation V8

March 2009

- Revised Note 2 to refer to 251 detail for riprap apron
- Minor drafting edits

August 2014

- Updated for FP-14
- Updated border