

User: \_\_\_\_\_  
 9:54:05 AM N:\CFL-DPIT\Drawings\FP-14\FP14\_Details\C157-53.dgn  
 9/22/2014

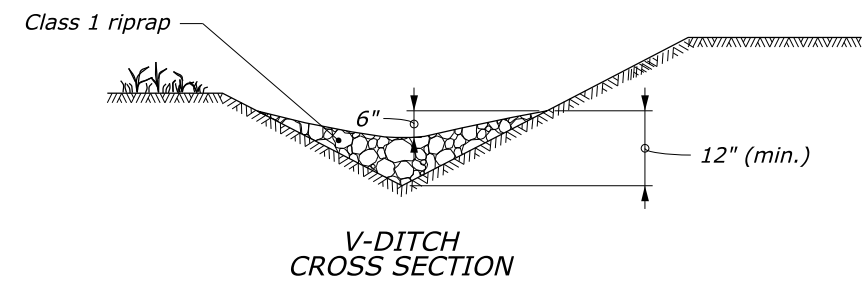

**NOTE:**

1. Check dams of fiber rolls, riprap, or gravel bags may be used as approved by the CO, to meet the functional requirements of the check dam device.
2. Repair all rills or gullies and properly compact prior to installation.
3. Install check dams in ditches perpendicular to the flowline.
4. Stake fiber rolls in place with 1 1/8" x 1 1/8" wood stakes. Drive stakes at each end of the fiber roll and at 2' (max) spacing.
5. Drive stakes into undisturbed soil of trench bottom 16" (min). Expose stakes 2" (min.) above top of fiber roll.
6. Provide sufficient length to prevent water from flowing around the ends of the fiber roll.
7. Adjust check dam spacing based on site-specific conditions.

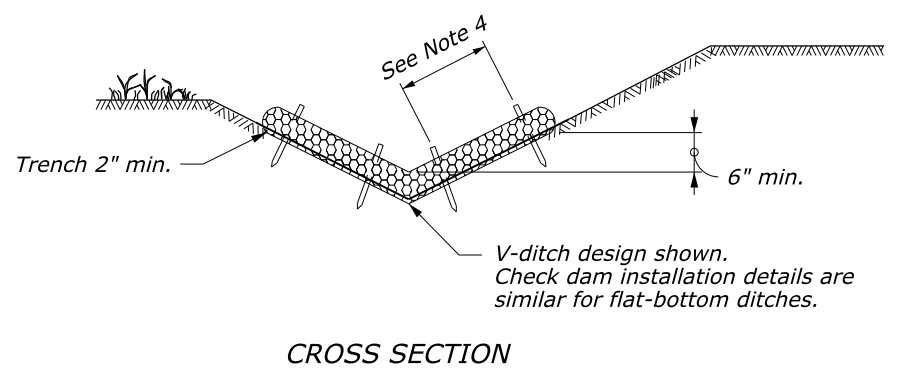
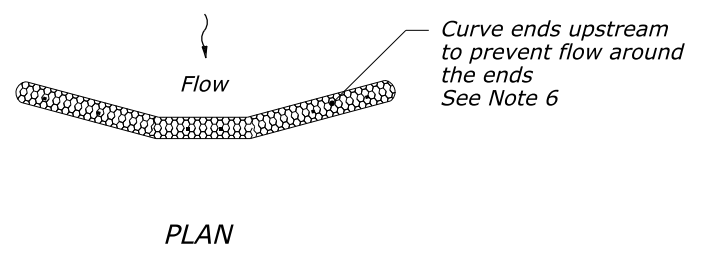
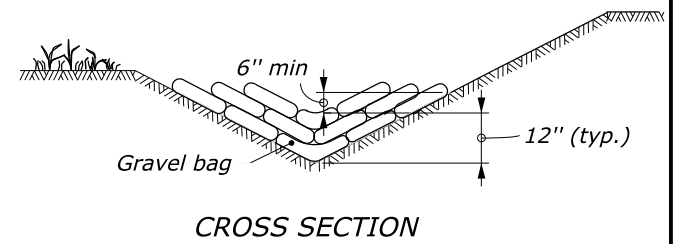
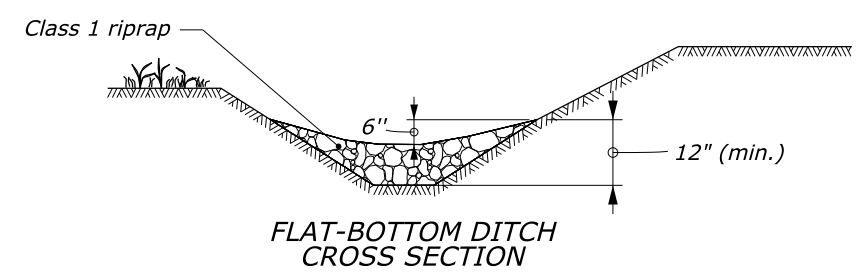
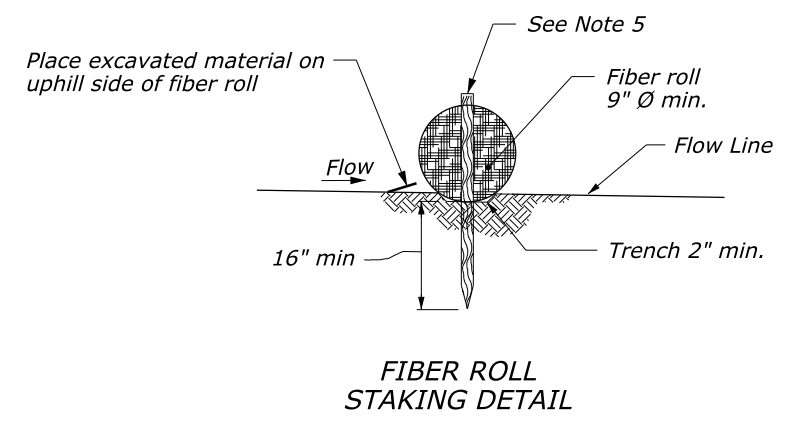

RIPRAP CHECK DAM SPACING (See Note 7)	
DITCH GRADE	CHECK DAM SPACING (max.) (ft)
2%	150
3%	100
4%	80
5%	60
6%	50

GRAVEL BAG CHECK DAM SPACING* (See Note 7)	
DITCH GRADE	CHECK DAM SPACING (max.) (ft)
2%	150
3%	100
4%	80
5%	60
6%	50

\* Do not use gravel bag check dams on ditch grades steeper than 6%

FIBER ROLL CHECK DAM SPACING* (See Note 7)	
DITCH GRADE	CHECK DAM SPACING (max.) (ft)
2%	150
3%	100
4%	80
5%	60

\* Spacing calculated based on 9" Ø min sediment log. Do not use sediment log check dams on ditch grades steeper than 5%.

**RIPRAP CHECK DAM**

**GRAVEL BAG CHECK DAM**

**FIBER ROLL CHECK DAM**

U.S. DEPARTMENT OF TRANSPORTATION FEDERAL HIGHWAY ADMINISTRATION CENTRAL FEDERAL LANDS HIGHWAY DIVISION	
U.S. CUSTOMARY DETAIL	
<b>CHECK DAM</b>	
DETAIL APPROVED FOR USE 01/2011 REVISED: 08/2014	DETAIL <b>C157-53</b>

NO SCALE

## NOTES TO THE DESIGNER

Last Updated: August 2014

---

### General Information

1. **Appropriate Applications.** Check dams reduce scour in a channel or ditch and provide runoff treatment by reducing flow velocity and encouraging sediment deposition. Appropriate applications include:
  - Fiber rolls are appropriate for lower flow conditions, gravel bags and riprap check dams in higher flow conditions
  - Steep channels where storm water runoff velocities exceed 3 ft/s
  - During the establishment of grass linings in ditches
  - Use in conjunction with RECP lining in ditches steeper than 5% or 6% (See CFL Detail C157-54)
2. **Limitations.**
  - Not used in live streams
  - Drainage areas 10 acres or less
3. **Layout Guidance.**
  - Install the first check dam about 15 ft from the outfall and at regular intervals based on slope gradient and soil type (steeper slopes and more erosive soils (e.g. loose sand or silt) will require shorter spacing between check dams).
  - When installing a series of check dams in a channel, install outlet stabilization measures below the final dam, such as riprap or geotextile, to minimize erosion potential.

---

### Applicable SCRs

None

---

### Typical Pay Item Used

- We will leave it up to the Contractor to select the specific type of drop inlet protection to use on the project. Include both plan sheets and a generic pay item in the PS&E.
- 15706-0200 Soil erosion control, check dam [EA]
- If you would like to specify a type of check dam to use, show the type in parenthesis in the pay item description. For example Soil erosion control, check dam (riprap)

---

### Updates

January 2011

- Updated FLH Standard drawing by: Adding sediment log and gravel bag check dams

August 2014

- Changed spacing tables, size of fiber roll
- Updated for FP-14
- Updated border