

LENGTH AND SPACING TABLE							
APPROACH SPEED*		BUFFER SPACE LENGTH	CHANNELIZING DEVICE			CONCRETE BARRIER FLARE RATE	WORK ZONE CLEAR ZONE WIDTH METER
			TAPER AREA	BUFFER SPACE	WORK SPACE		
MPH	km/h	SPACING IN METERS					
20	30	35	6	12	12	1:8	3.0
25	40	45	6	15	15	1:8	3.0
30	50	60	6	18	18	1:8	3.0
35	55	75	6	21	21	1:9	3.0
40	65	95	6	24	24	1:10	4.6
45	70	110	6	27	27	1:12	6.1
50	80	130	6	30	30	1:14	6.1
55	90	150	6	34	34	1:16	6.1
60	95	175	6	37	37	1:16	9.0
65	105	195	6	40	40	1:16	9.0
70	115	225	6	43	43	1:16	9.0

* Approach speed based on the regulatory posted speed, not the advisory speed.

NOTE:

1. Install signs and other devices for single lane closure according to Standard M635-6, 7, 8, or 9. Final location and spacing of signs and devices may be changed to fit field conditions as approved by the CO.
2. Place barrier according to the AASHTO Roadside Design Guide. Terminate barrier ends outside the work zone clear zone or protect the barrier ends with a crash cushion. Include reflectors on barrier at 7.6 m intervals.
3. For project specific minimum width, refer to Special Contract Requirements, Section 156.
4. Place channelizing devices at downstream taper during non-work hours or when access is not needed.
5. Do not allow equipment, materials, or vehicles to be parked or stored in the buffer space.
6. Reduce or eliminate drums and barrier in downstream taper if necessary to provide access to work space.

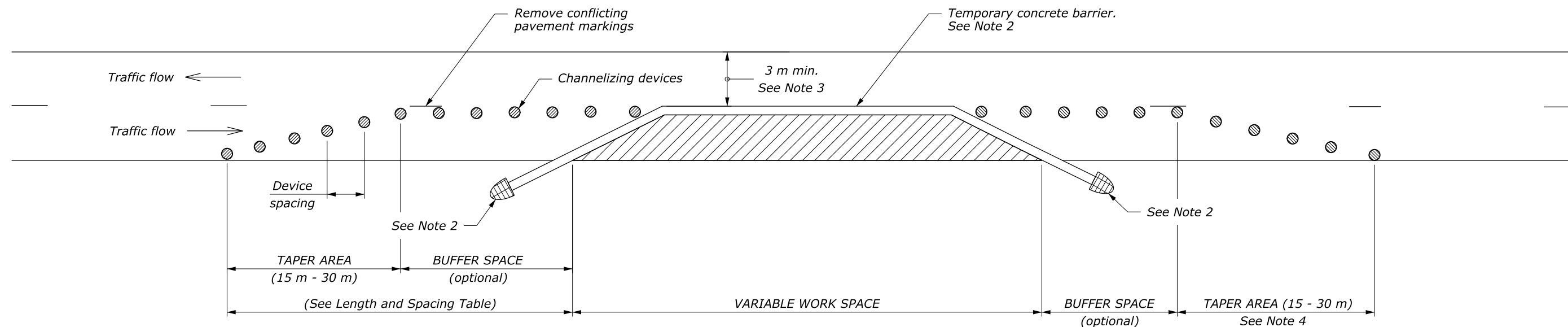

NO SCALE

U.S. DEPARTMENT OF TRANSPORTATION FEDERAL HIGHWAY ADMINISTRATION FEDERAL LANDS HIGHWAY	
METRIC STANDARD	
TEMPORARY TRAFFIC CONTROL SINGLE LANE CLOSURE LAYOUT (WITH TEMPORARY BARRIER)	
STANDARD APPROVED FOR USE 6/2005	STANDARD
REVISED: DRAFT: 6/2015	M635-13