

**SECTION VIEW**

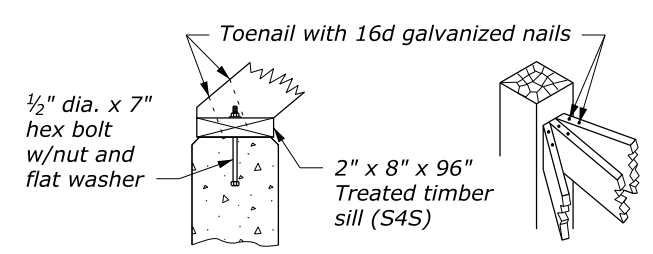

**DETAIL A**

**DETAIL B**

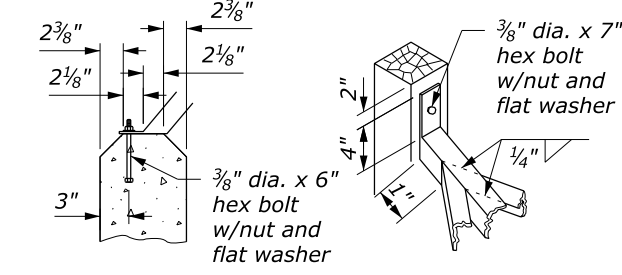

**DETAIL C**

**DETAIL D**

**NOTE:**

- LOADING: AASHTO HS20.
- CONCRETE: Chamfer exposed edges 3/4" unless otherwise shown. Give all concrete surfaces a Class 1 finish.
- STRUCTURAL STEEL: Provide rails conforming to the requirements for ASCE 40 crane rail. Provide structural steel for alternate sections conforming to ASTM A 500, Grade B, Copper Steel or ASTM A 618, Grade 2. If the steel does not contain a minimum of 0.2 percent copper, galvanize the alternate sections. All other structural steel conforms to AASHTO ASTM A36 and is painted.
- Provide 2" minimum concrete cover to the face of any bar unless otherwise shown. All bars are #4.
- All welds are continuous 1/4" fillet shop welds. Weld rail or alternate sections on both sides to the W 8 x 18 beams at each intersection. Weld according to Section 555.
- Use aluminum alloy 6061-T6 or 6063-T6 for aluminum tubing.
- Provide timber conforming to AASHTO M 168. Treat timber with chromated copper arsenate according to AASHTO M 133.
- Galvanize all hardware according to AASHTO M 111.
- Construct the cattle guard to conform with the finished roadway grade and template.
- Place one object marker at each corner of the cattle guard as shown. Mount object markers on 4" x 4" x 6'-0" posts with the reflector located 42" above the elevation of the lateral support concrete.
- Install drain pipe as shown where required. Include drain pipe with cattle guard unless otherwise shown.
- Unless otherwise shown in the Special Contract Requirements, shop apply paint system 2 according to Section 555 and color the top coat according to Federal Standard 595B, Gray, 36231. Repair any damage to the paint system during installation.
- Install channels and wood blocking on cattle guards wider than 16 feet to maintain grate spacing as shown on Standard 619-2.
- See Standard 619-3 for optional precast foundation details.

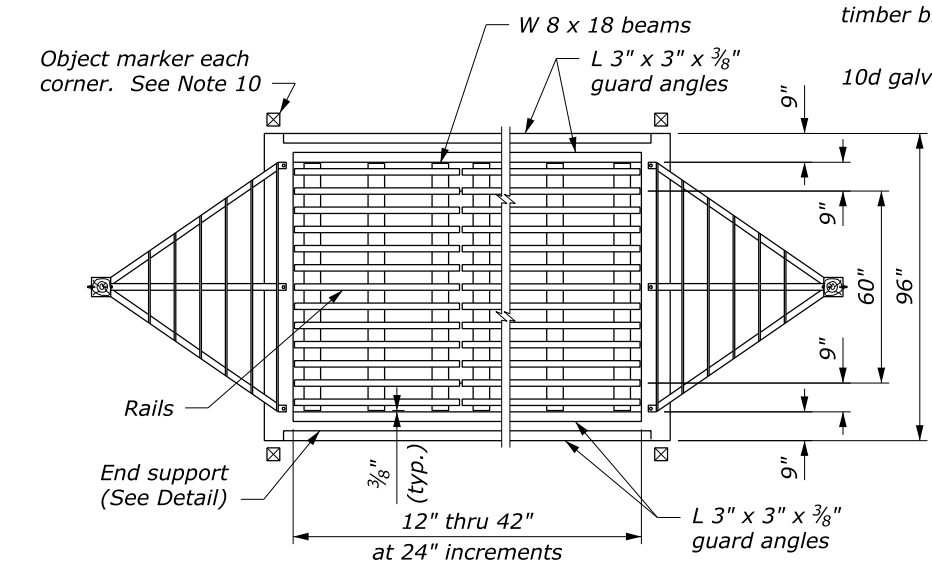

**PLAN**

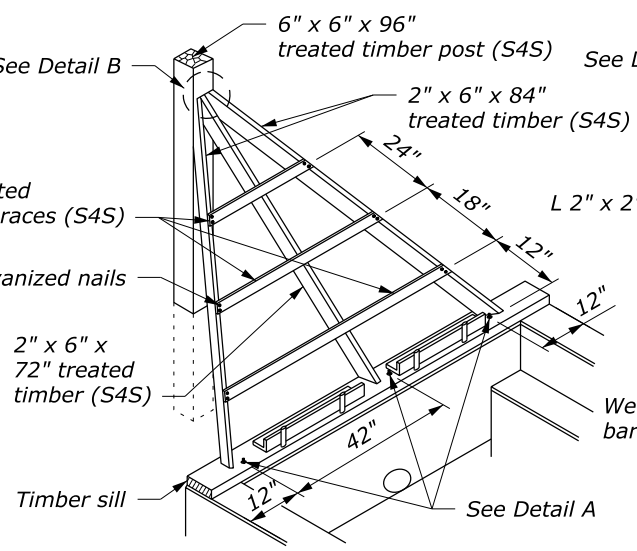

**WOOD WING GUARD**

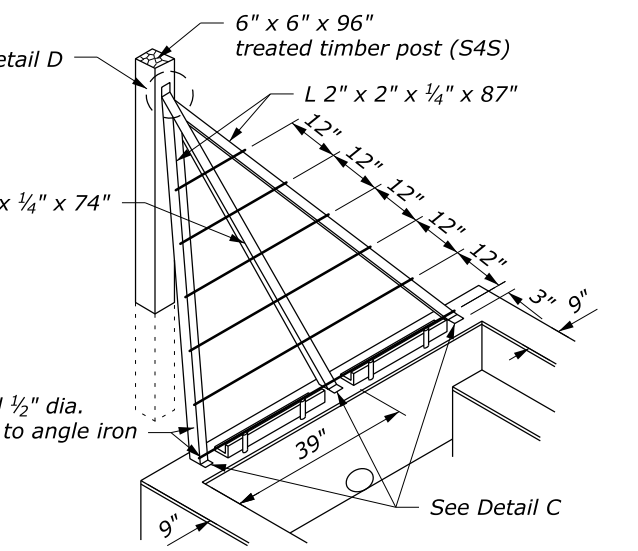

**ANGLE IRON WING GUARD**

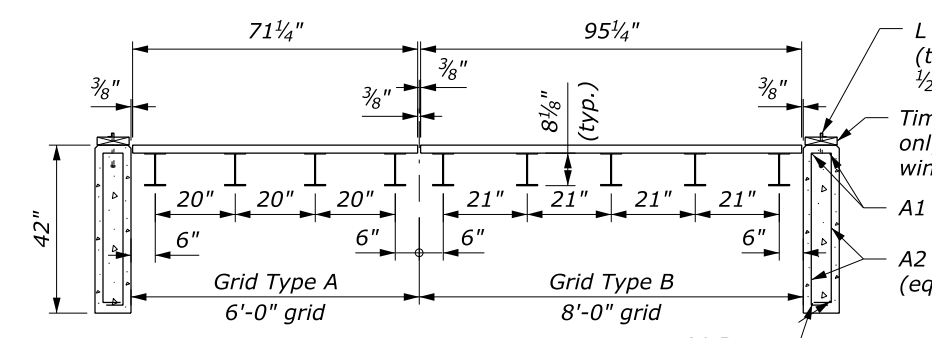

**STANDARD GRID UNIT TYPES**

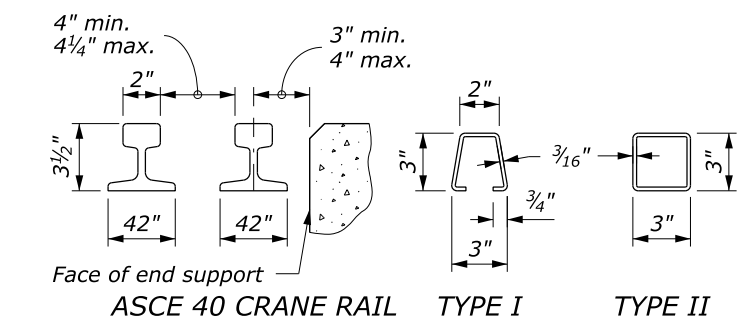

**ACCEPTABLE ALTERNATE RAIL**

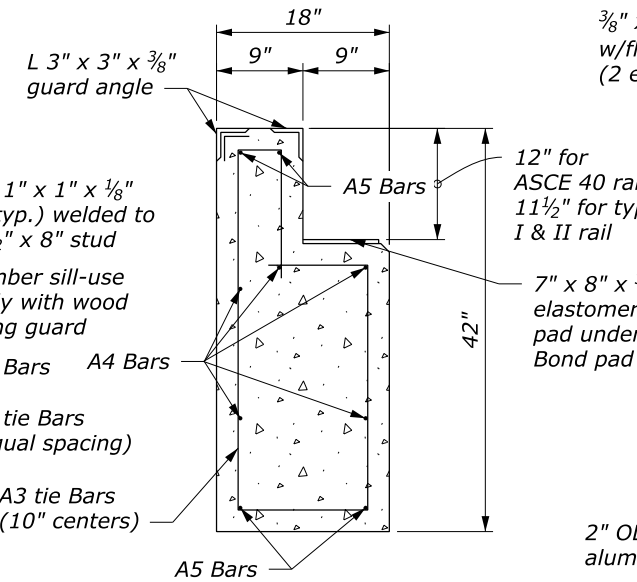

**END SUPPORT DETAIL**

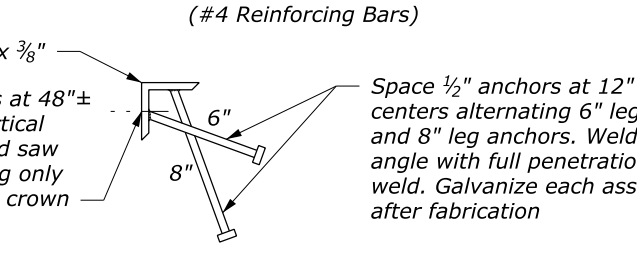

**GUARD ANGLE DETAIL**

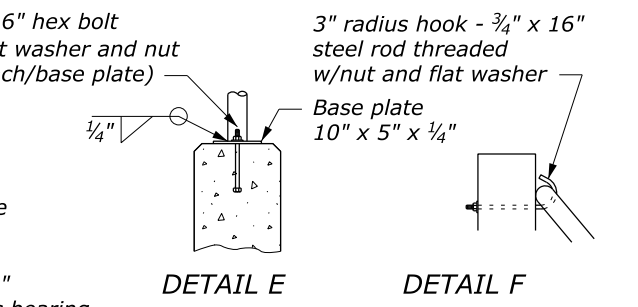

**DETAIL E**

**DETAIL F**

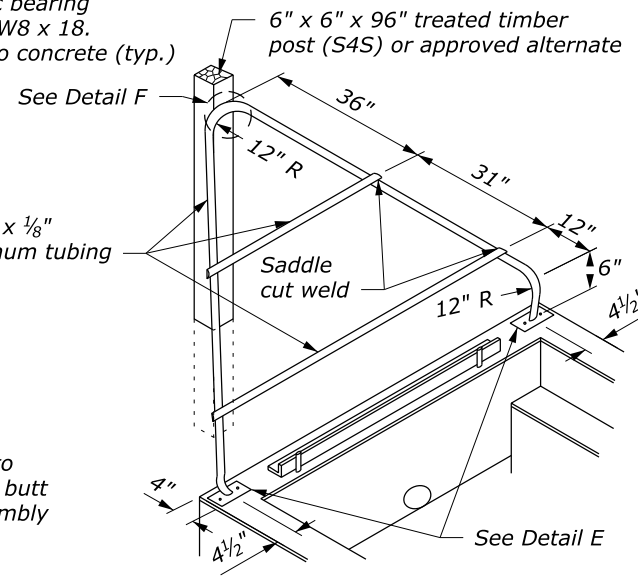

**ALUMINUM TUBING WING GUARD**

NO SCALE

U.S. DEPARTMENT OF TRANSPORTATION FEDERAL HIGHWAY ADMINISTRATION FEDERAL LANDS HIGHWAY	
U.S. CUSTOMARY STANDARD	
<b>CATTLE GUARD</b>	
STANDARD APPROVED FOR USE 6/2005	STANDARD
REVISED: DRAFT: 10/2016	619-1

C:\MyFiles\pw\_production\dfs67488\Std619-1.dgn [USC] 5 October 2016 4:21 PM