





CONCRETE ROUND PIPE CULVERT

PIPE SIZE DIAMETER INCHES	FILL HEIGHT AND PIPE CLASS TABLE								
	EMBANKMENT				TRENCH				
	MINIMUM COVER INCHES	CLASS II	CLASS III	CLASS IV	CLASS V	CLASS II	CLASS III	CLASS IV	CLASS V
12	12	10	10	15	23	18	18	26	13
18	12	10	10	25	39	13	13	31	45
24	12	10	10	15	30	15	15	22	40
30	12	9	13	15	35	13	16	20	46
36	12	9	9	20	41	10	13	26	56
48	12	12	13	26	44	15	16	30	49
60	12	15	17	28	44	15	20	32	49
72	12	13	17	30	41	15	20	35	49
84	12	13	19	30		15	23	37	
96	12	13	20			15	24		
108	14	15	20			18	26		

LEGEND:

-  Bedding material (uncompacted).
-  Embankment material placed in layers not exceeding 6" compacted depth.
-  Compacted backfill material placed in layers not exceeding 6" compacted depth, or lean concrete backfill in accordance with Section 614
-  Impermeable backfill material.

NOTE:

- When directed, camber pipe culverts upwards from a chord through the inlet and outlet inverts an ordinate amount equal to 1% of the pipe length. Develop camber on a parabolic curve. If the midpoint elevation on the parabolic curve as designed exceeds the elevation of the inlet invert, reduce the amount of camber or increase the pipe culvert gradient.
- Measure minimum cover from the top of the pipe culvert to the subgrade for flexible pavements, and to the top of the pavement for rigid pavements. Measure maximum fill height from the top of the pipe to the top of the pavement for both flexible and rigid pavements.
- Pipe compaction limits shown are for pipe installation in an embankment. For pipe installation in a trench, the compaction limits shall be the walls of the trench.
- Where unyielding or unstable material is encountered, install the pipe culvert according to the limits of pipe compaction shown on Standard 602-3.
- Maximum fill heights for pipe culvert installations may be increased on approval of site-specific structural pipe designs meeting the criteria of AASHTO Standard Specifications for Highway Bridges.
- Use Supplemental Concrete Pipe Tie when specified in the contract documents.

BEDDING DEPTH	
PIPE SIZE (H)	DEPTH
12" TO 54"	4"
> 54"	6"

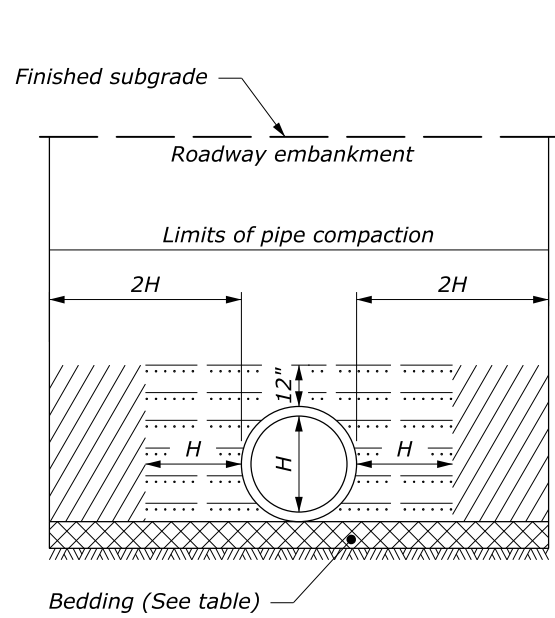

EMBANKMENT INSTALLATION

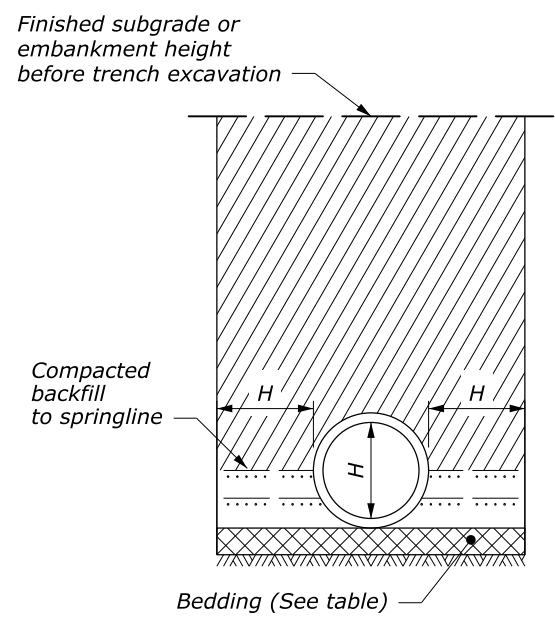

TRENCH INSTALLATION

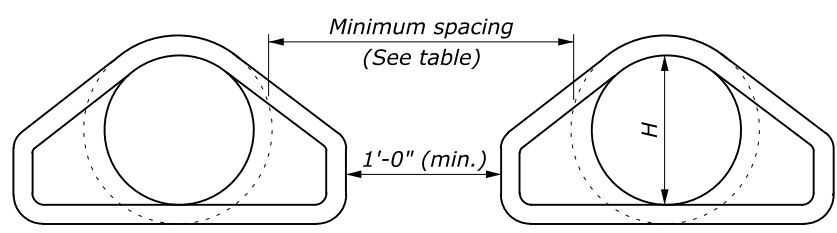

MULTIPLE ROUND PIPE INSTALLATION

DIAMETER	MINIMUM SPACING	
	EMBANKMENT	TRENCH
12"-36"	15"	2H
36"-96"	0.5H	72"
OVER 96"	48"	72"

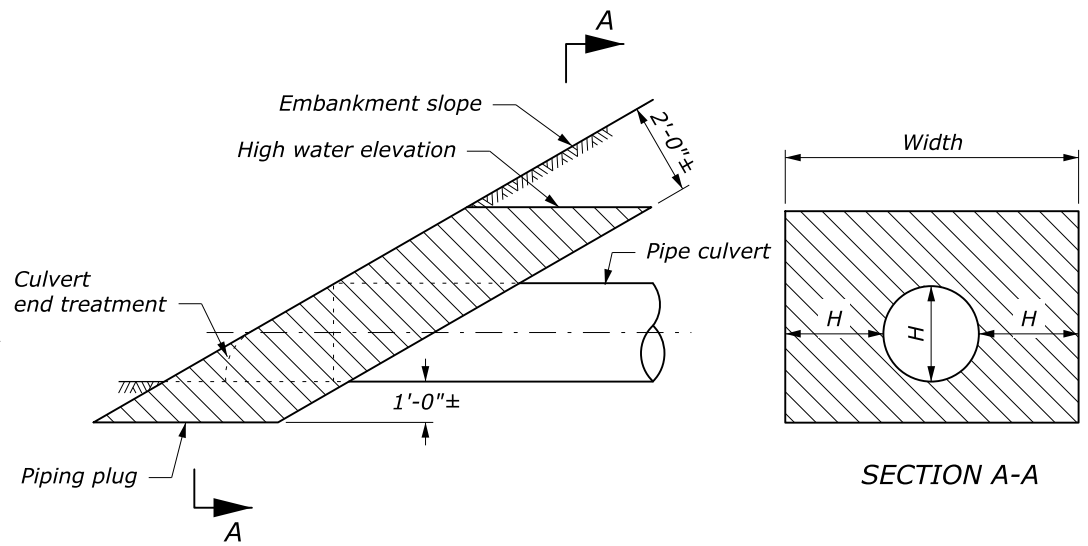

Construct a piping plug of impermeable backfill material at the pipe inlet where granular material is used for backfill. Width may be adjusted to tie into impervious material.

PIPING PLUG

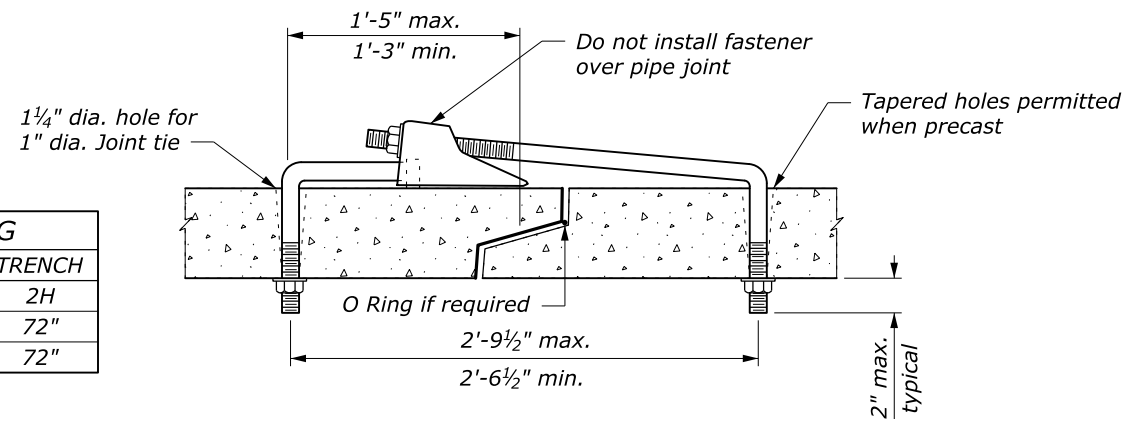
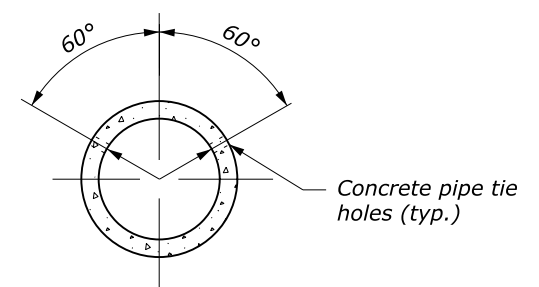

SUPPLEMENTAL CONCRETE PIPE TIE

NO SCALE

U.S. DEPARTMENT OF TRANSPORTATION
FEDERAL HIGHWAY ADMINISTRATION
FEDERAL LANDS HIGHWAY

U.S. CUSTOMARY STANDARD

**CONCRETE PIPE
CULVERT INSTALLATION**

STANDARD APPROVED FOR USE 12/1993
REVISED: 4/1994 6/2005
DRAFT: 6/2008

STANDARD
602-7