

**NOTE:**

1. Use straw bales in drainage ditches only for low flow conditions and when specified on the Erosion Control Plans.

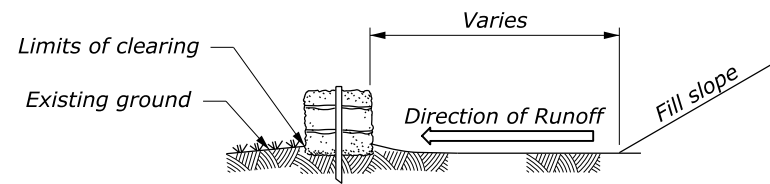

**ELEVATION**

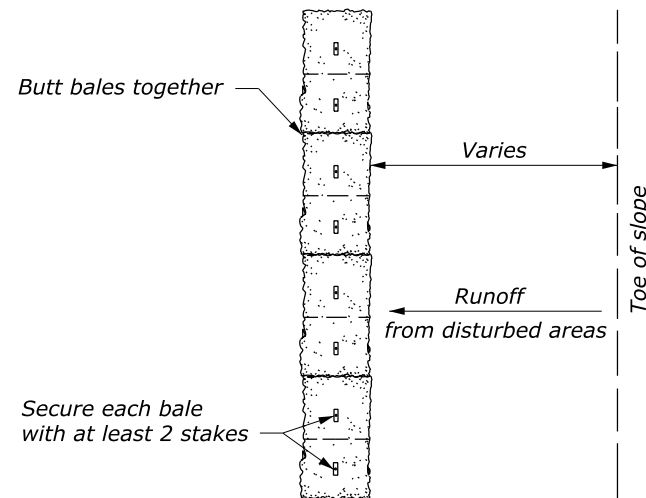

**PLAN**

**INSTALLATION OF A STRAW BALE BARRIER AT TOE OF FILL**

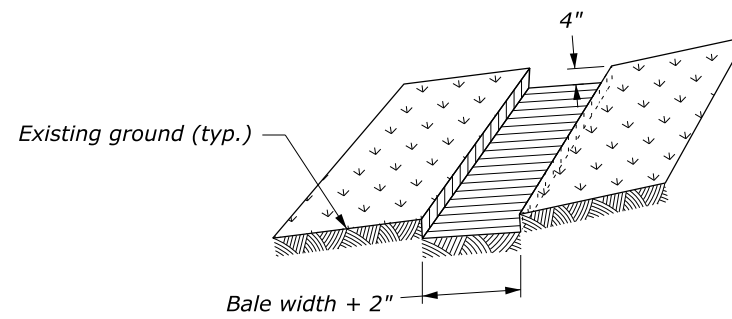

**Step 1: Excavate trench**

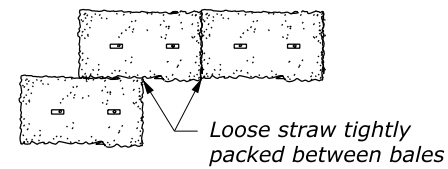

**Step 3: Tightly pack straw between bales (plan view of bales)**

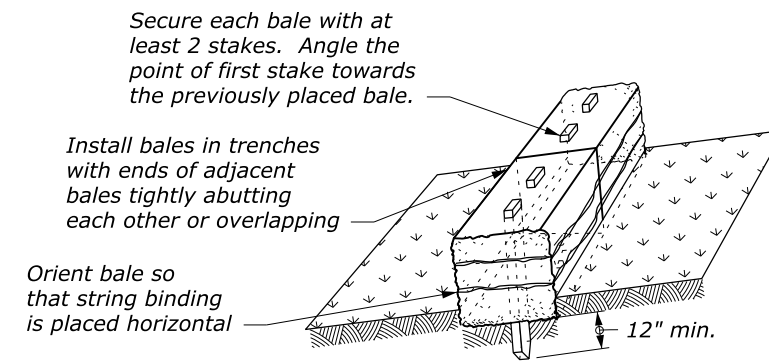

**Step 2: Install bales**

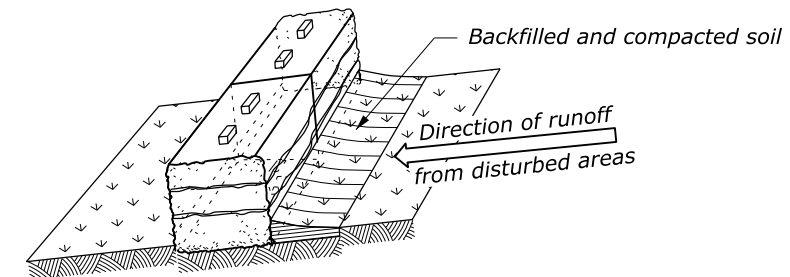

**Step 4: Backfill soil against bales**

**PROPERLY STAKED AND ENTRENCHED STRAW BALES**

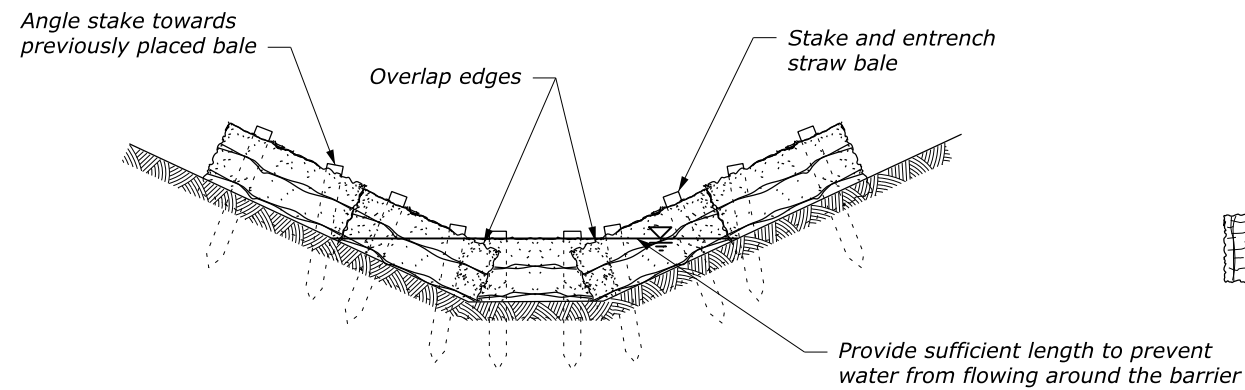

**ELEVATION**

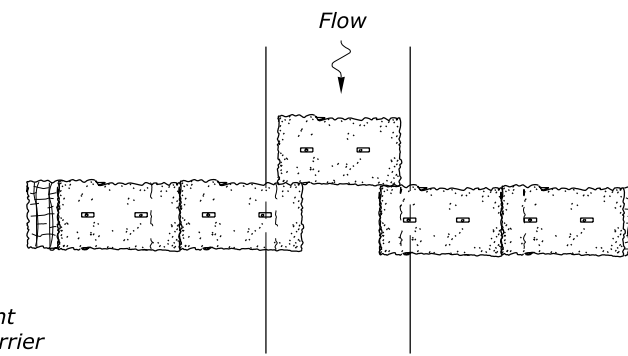

**PLAN**

**INSTALLATION OF A STRAW BALE BARRIER IN DITCH**

See Note 1

NO SCALE

U.S. DEPARTMENT OF TRANSPORTATION FEDERAL HIGHWAY ADMINISTRATION FEDERAL LANDS HIGHWAY	
U.S. CUSTOMARY STANDARD	
<b>STRAW BALES</b>	
STANDARD APPROVED FOR USE 6/2005 REVISED: 6/2007	STANDARD 157-3