

NOTE:

1. Install logs for rails butt to butt and tip to tip. A 2" maximum taper between the butt and tip ends of individual logs is permitted.
2. 20 foot logs are acceptable for rails provided the 2" maximum taper requirement is met and roadway curvature permits.
3. Make splices in rail elements at posts only.
4. Field cut log ends and dress as necessary to obtain tight fitting butt joints in full contact with each other at the log ends. Trim traffic exposed faces of log ends at the joints and elsewhere and dress as necessary to obtain a smooth surface with no protrusions.
5. Dress back face of log rail members to provide a flat surface wide enough to accommodate a 6" steel rail.
6. Apply an approved tinted brown color stain to all exposed surfaces of logs. Apply stain either as a part of or subsequent to preservative treatment.
7. Treat all field cuts and drill holes with two applications of the same preservative and stain as the rails and posts.
8. The nominal bolt length is 16". Bolt lengths will vary according to log size. Extra long threaded bolts may be used, provided they are field cut so that none of the shank protrudes beyond the back of the post.

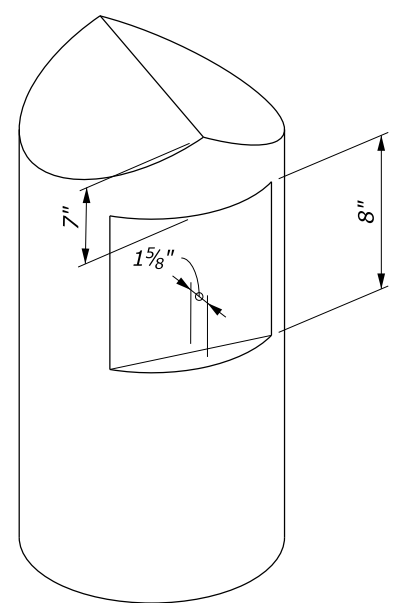

POST NOTCH FOR WOOD BLOCK-OUT

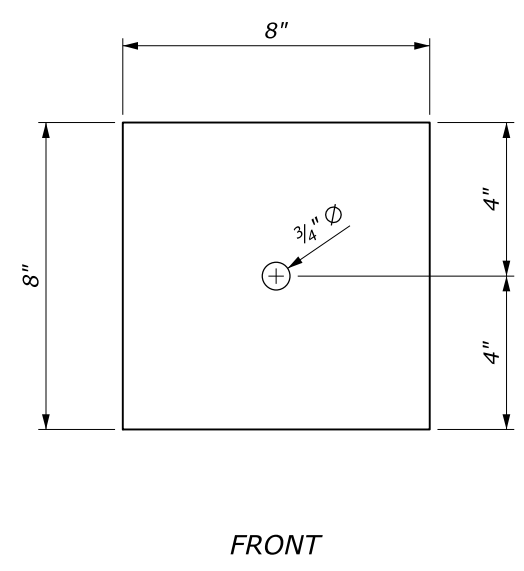
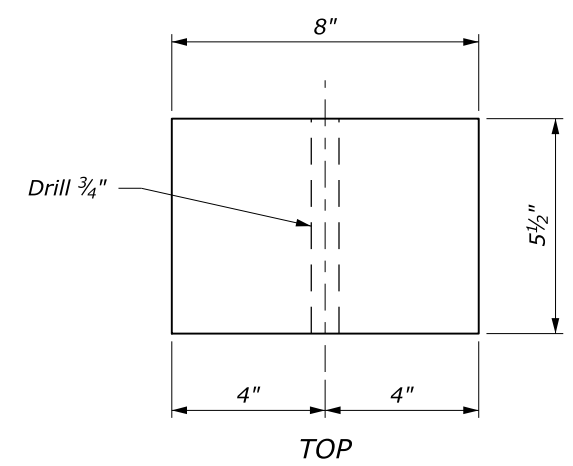

WOOD BLOCK-OUT
8" x 5 1/2" x 8"

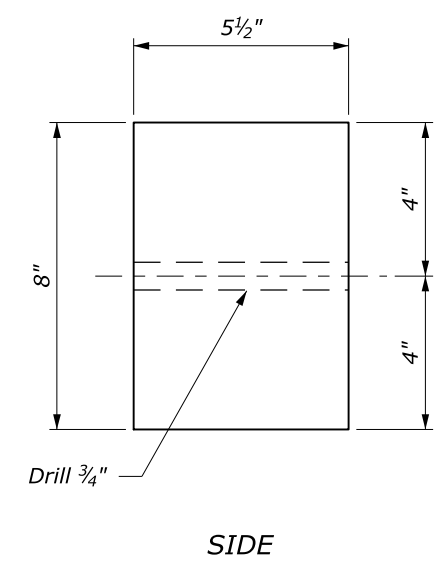

U.S. DEPARTMENT OF TRANSPORTATION FEDERAL HIGHWAY ADMINISTRATION FEDERAL LANDS HIGHWAY	
U.S. CUSTOMARY STANDARD	
STEEL-BACKED LOG RAIL BLOCKOUT	
STANDARD APPROVED FOR USE 6/2005	STANDARD
REVISED: DRAFT: 11/2013	617-81

NO SCALE