

PLAN

NOTE:

1. Pay limits for terminal section type LST include the in-line anchorage assembly and posts 1-5.
2. Use offset from face of rail to slope break as shown unless otherwise shown on plan.
3. Posts 1, 2 and 5 are standard guardrail posts. See Standard 617-10 for details.
4. See Standard 617-15 for other details.
5. Do not use LST terminal where speeds are in excess of 45 MPH.

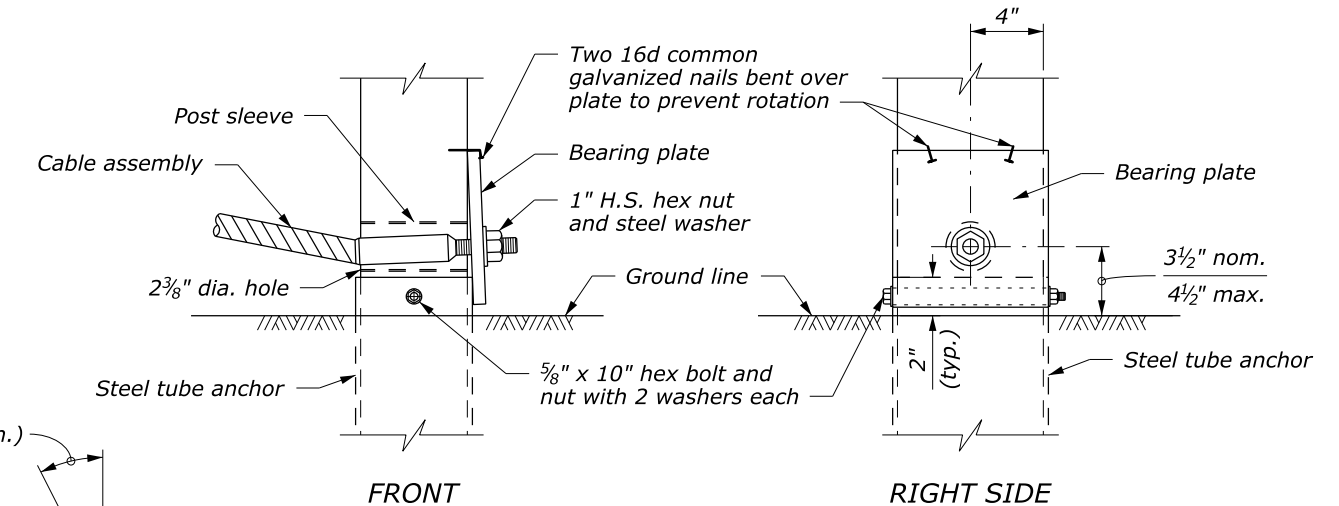

**DETAIL A
POST #3 ASSEMBLY**

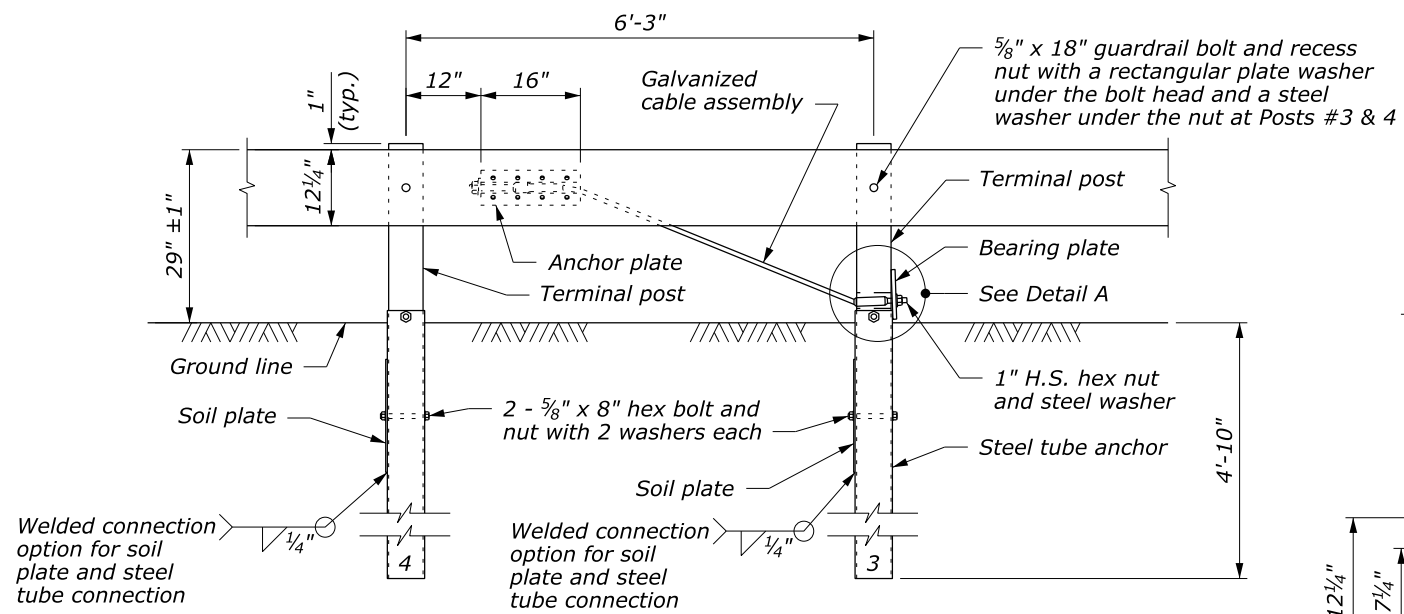

**ELEVATION
IN-LINE ANCHORAGE ASSEMBLY**

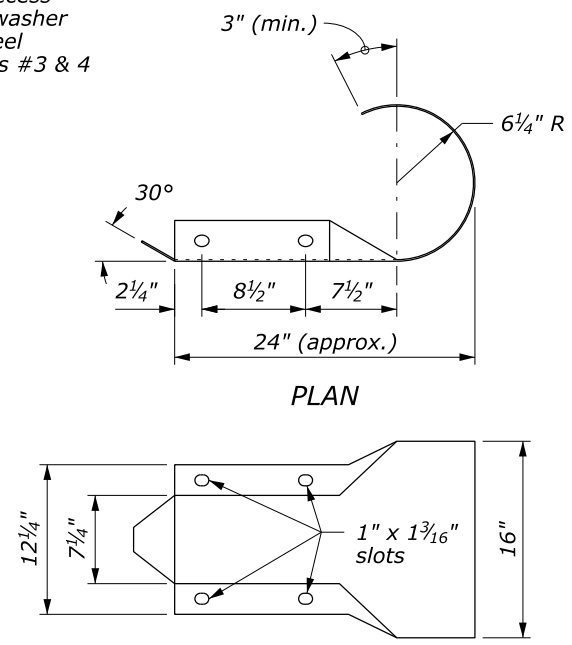

**ELEVATION
ROUNDED END SECTION**

U.S. DEPARTMENT OF TRANSPORTATION FEDERAL HIGHWAY ADMINISTRATION FEDERAL LANDS HIGHWAY	
U.S. CUSTOMARY STANDARD G4 W-BEAM GUARDRAIL LOW SPEED TERMINAL TYPE LST, WOOD POSTS	
STANDARD APPROVED FOR USE 6/2005	STANDARD
REVISED: DRAFT: 12/2014	617-14

c:\myfiles\pw_production\dms67487\Std.617-14.DRAFT.dgn [USC] 15 December 2014 1:25 PM