

PLAN

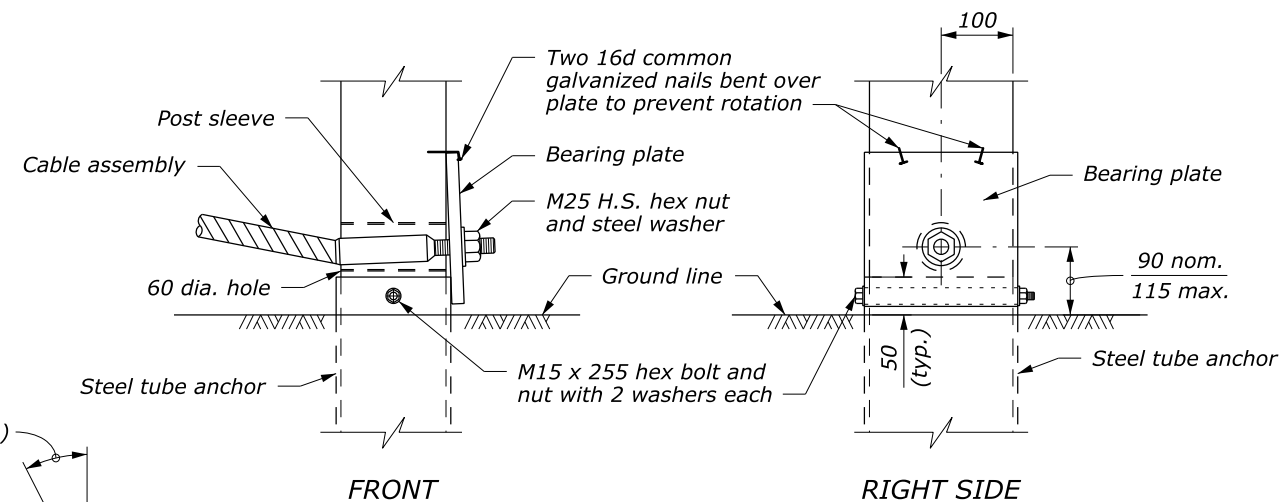

DETAIL A
POST #3 ASSEMBLY

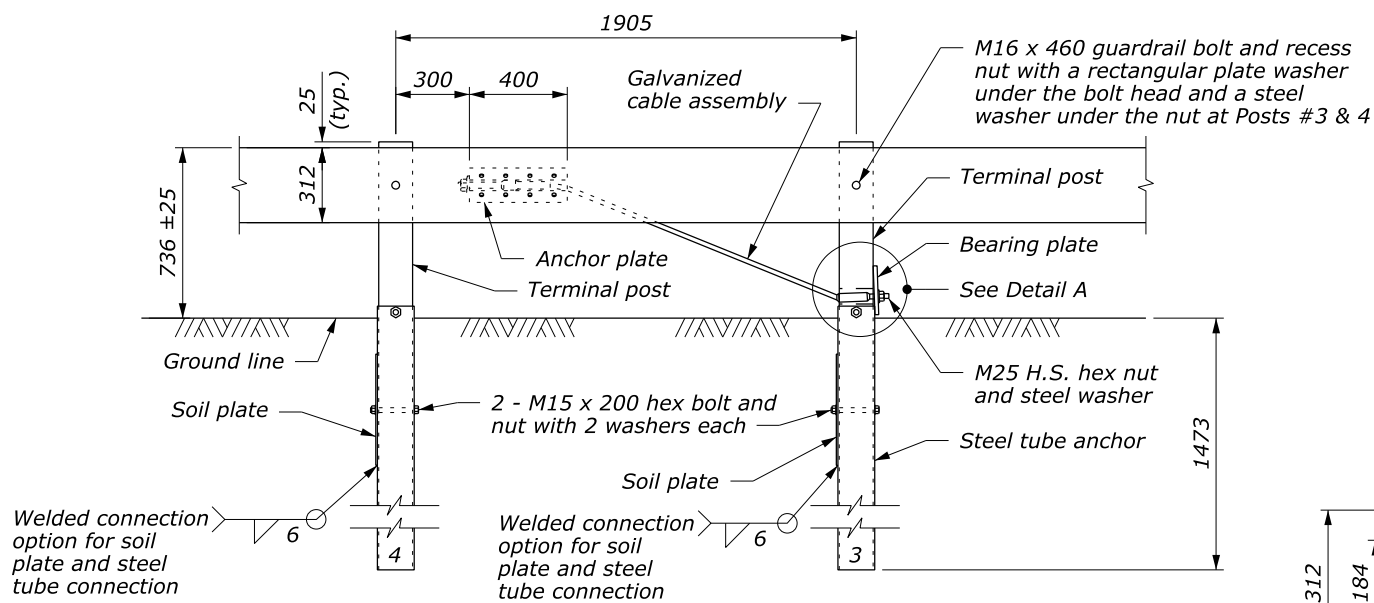

ELEVATION
IN-LINE ANCHORAGE ASSEMBLY

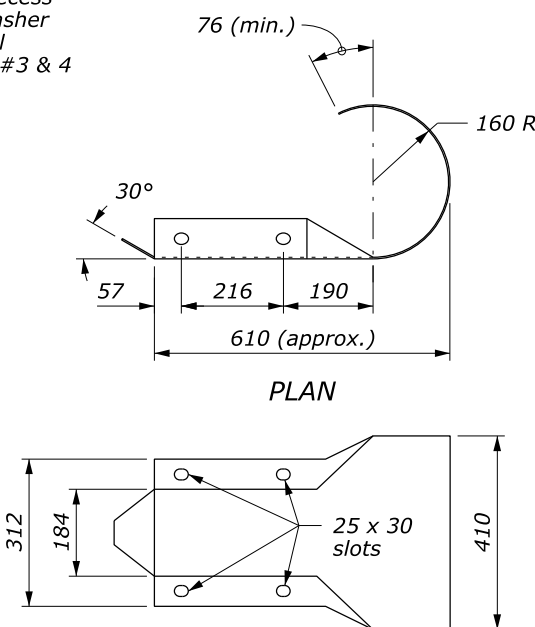

ELEVATION
ROUNDED END SECTION

NOTE:

1. Pay limits for terminal section type LST include the in-line anchorage assembly and posts 1-5.
2. Use offset from face of rail to slope break as shown unless otherwise shown on plan.
3. Posts 1, 2 and 5 are standard guardrail posts. See Standard M617-10 for details.
4. See Standard M617-15 for other details.
5. Do not use LST terminal where speeds are in excess of 70 km/h [45 MPH].
6. Dimensions without units are millimeters.

NO SCALE

U.S. DEPARTMENT OF TRANSPORTATION FEDERAL HIGHWAY ADMINISTRATION FEDERAL LANDS HIGHWAY	
METRIC STANDARD	
G4 W-BEAM GUARDRAIL LOW SPEED TERMINAL TYPE LST, WOOD POSTS	
STANDARD APPROVED FOR USE 6/2005	STANDARD
REVISED: DRAFT: 12/2014	M617-14