

**WFLHD SUPPLEMENTS TO NATIONALLY DEVELOPED
STANDARD TEST PROCEDURES
TABLE OF CONTENTS**

Test Procedure	Subject	Page
T 2-94	Sampling Aggregates	T2-1W
T 11-94	Amount of Material Finer Than 75 μm (200) Sieve in Aggregate	T11-1W
T 23-94	Making and Curing Concrete Test Specimens in the Field in Finishing and Handling Equipment	T23-1W
T 24-94	Obtaining and Testing Drilled Cores and Sawed Beams of Concrete or Asphalt Pavements	T24-1W
T 27-94	Sieve Analysis of Fine and Coarse Aggregates	T27-1W
T 30-94	Mechanical Analysis of Extracted Aggregate	T30-1W
T 40-94	Sampling Asphalt Materials	T40-1W
T 87-94	Dry Preparation of Disturbed Soil and Soil Aggregate Samples for Test	T87-1W
T 89-94	Determining the Liquid Limit of Soils	T89-1W
T 90-94	Determining the Plastic Limit and Plasticity Index of Soils	T90-1W
T 99-94	The Moisture-Density Relations of Soils Using a 2.495 kg (5.5 lb.) Rammer and a 304.8 mm (12 in.) Drop	T99-1W
T 110-94	Moisture in Asphalt Paving Mixture	T110-1W
T 119-94	Slump of Portland Cement Concrete	T119-1W
T 121-94	Weight Per Cubic Meter (Foot), Yield and Air Content	T121-1W
T 141-94	Sampling Fresh Concrete	T141-1W

**WFLHD SUPPLEMENTS TO NATIONALLY DEVELOPED
STANDARD TEST PROCEDURES
TABLE OF CONTENTS**

Test Procedure	Subject	Page
T 152-94	Air Content of Freshly Mixed Concrete by the Pressure Method	T152-1W
T 164-94	Quantitative Extraction of Asphalt From Asphalt Paving Mixtures	T164-1W
T 166-94	Bulk Specific Gravity of Compacted Asphalt Mixtures Using Saturated Surface-Dry Specimens	T166-1W
T 168-94	Sampling Asphalt Paving Mixtures	T168-1W
T 176-94	Plastic Fines in Graded Aggregates and Soils by Use of the Sand Equivalent Test	T176-1W
T 180-94	Moisture-Density Relations of Soils Using a 4.535 kg (10 lb.) Rammer and a 457.2 mm (18 in.) Drop	T180-1W
T 218-94	Sampling Hydrated Lime or Mineral Filler	T218-1W
T 224-94	Correction For Coarse Particles in the Soil Compaction Test	T224-1W
T 238-94	Density of Soil and Soil-Aggregate in Place by Nuclear Methods (Shallow Depth)	T238-1W
T 239-94	Moisture Content of Soil and Soil-Aggregate in Place by Nuclear Methods (Shallow Depth)	T239-1W
T 248-94	Reducing Field Samples of Aggregate to Testing Size	T248-1W
T 255-94	Total Moisture Content of Aggregate by Drying	T255-1W
T 265-94	Laboratory Determination of Moisture Content of Soils	T265-1W

Standard Method of

Sampling Aggregates

WFLHD Designation: T 2-94 (Modified AASHTO T 2)

1. SCOPE

1.1 This method covers sampling of coarse and fine aggregates for the following purposes:

1.1.1 Preliminary investigation of the potential source of supply,

1.1.2 Control of the product at the source of supply,

1.1.3 Control of the operations at the site of use, and

1.1.4 Acceptance or rejection of the materials.

2. APPLICABLE DOCUMENTS

2.1 AASHTO Standards: T 248 Reducing Field Samples of Aggregate to Testing Size.

3. SIGNIFICANCE AND USE

3.1 Sampling is equally as important as the testing, and the sampler shall use every precaution to obtain samples that will show the nature and condition of the materials which they represent.

3.2 Samples of materials for control of the production at the source or control of the work at the site of use are obtained by the manufacturer, contractor, or other parties responsible for accomplishing the work. Samples for tests to be used in acceptance or rejection decisions by the purchaser are obtained by the purchaser or his authorized representative.

Note 1 - The preliminary investigation and sampling of potential aggregate sources and types occupies a very important place in determining the availability and suitability of a major constituent entering into the construction. It influences the type of construction from the standpoint of economics and governs the necessary material control to ensure durability of the resulting structure, from the aggregate standpoint. This investigation should be done only by a responsible, trained and experienced person. For more comprehensive guidance, see Appendix.

4. SECURING SAMPLES

4.1 General - Where practicable, samples to be tested for quality shall be obtained from the finished product.

4.2 Inspection - The contractor shall provide for inspection of his operation and the sampling of the product. If the inspector or inspectors note that the aggregate is nonuniform, immediate corrective action shall be taken. Samples should be taken at specified intervals to show that the process is under control.

4.3 Procedure:

4.3.1 Sampling from a Flowing Aggregate Stream (Bins or Belt Discharge) -

Select units to be sampled by a random method. Obtain a field sample whose mass equals or exceeds the minimum recommended in Section 4.4.2. Take each sample from the entire cross section of the material as it is being discharged. It is usually necessary to have a special device constructed for use at each particular plant. This device consists of a pan of sufficient size to intercept the entire cross section of the discharge stream and hold the required quantity of material without overflowing. A set of rails may be necessary to support the pan as it is passed under the discharge stream. Insofar as is possible, keep bins continuously full or nearly full to reduce segregation.

Note 2 - Sampling the initial discharge or the final few tons from a bin or conveyor belt increases the chances of obtaining segregated material and should be avoided.

4.3.2 Sampling from the Conveyor Belt - Select units to be sampled by a random method. Obtain a field sample whose mass equals or exceeds the minimum recommended in Section 4.4.2. Stop the conveyor belt while the sample is being obtained. Insert two templates, the shape of which conforms to the shape of the belt and the aggregate stream on the belt, or mark two transverse lines across the belt and space them such that the material contained between them will yield a sample of the required weight. Carefully remove all material between the templates or transverse marks and place into a suitable container. Collect the fines on the belt with a brush and dust pan and add to the container. See Figure 1.

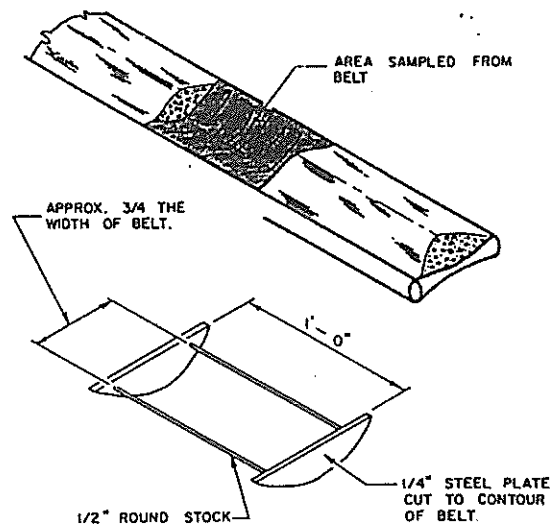

TYPICAL TEMPLATE TO DRAG
SAMPLE OFF BELT.

TYPICAL TEMPLATE

FIGURE 1

4.3.3 Sampling from Stockpiles or Transportation Units - Avoid sampling coarse aggregate or mixed coarse and fine aggregate from stockpiles or transportation units whenever possible, particularly when the sampling is done for the purpose of determining aggregate properties that may be dependent upon the grading of the sample. If circumstances make it necessary to obtain samples from a stockpile of coarse aggregate or a stockpile of combined coarse and fine aggregate, design a sampling plan for the specific case under consideration. This approach will allow the sampling agency to use a sampling plan that will give a confidence in results obtained therefrom that is agreed upon by all parties concerned to be acceptable for the particular situation. The sampling plan shall define the number of samples necessary to represent lots and/or sublots of specific sizes. General principles for sampling from stockpiles are applicable to sampling from trucks, rail cars, barges, or other transportation units. For general guidance in sampling from stockpiles, see Appendix X1.2.

4.3.4 Sampling from roadway (Bases and Subbases) - Select units to be sampled by a random method. Obtain a field sample whose mass equals or exceeds the minimum recommended in Section 4.4.2. Take all samples from the roadway for the full depth of the material, taking care to exclude any underlying material.

4.3.5 Sampling from processed windrow - Select units to be sampled by a random method. Obtain a field sample whose mass equals or exceeds the minimum recommended in Section 4.4.2. Obtain the sample by one of the methods depicted in Figure 2 or 3.

4.4 Number and Masses of Field Samples:

4.4.1 The number of field samples (obtained by one of the methods described in Section 4.3) required depends on the criticality of, and variation in, the properties to be measured. Designate each unit from which a field sample is to be obtained prior to sampling. The number of field samples from the production should be sufficient to give the desired confidence in test results.

4.4.2 The field sample masses cited are tentative. The masses must be predicated on the type and number of tests to which the material is to be subjected and sufficient material obtained to provide for the proper execution of these tests. Standard acceptance and control tests are covered by AASHTO standards and specify the portion of the field sample required for each specific test. Generally speaking, the amounts specified in Table 1 will provide adequate material for routine grading. Extract test portions from the field sample according to T 248 or as required by other applicable test methods.

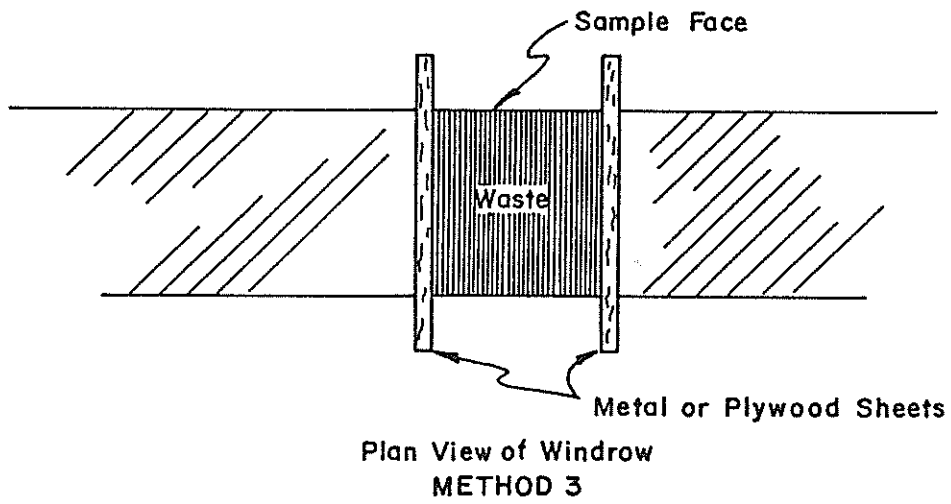
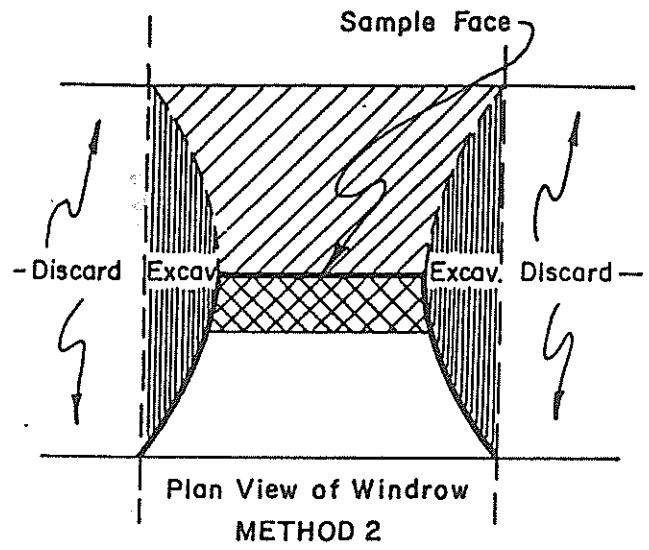
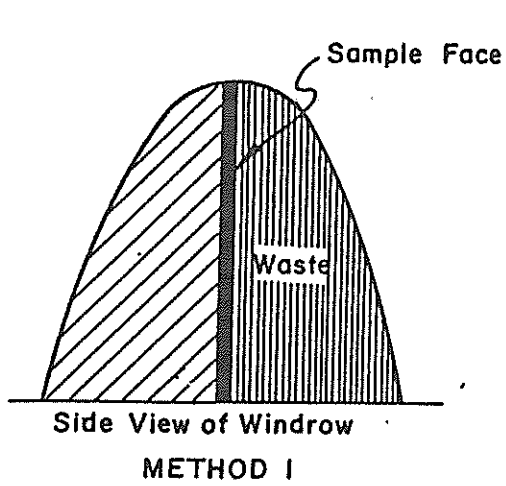

**WINDROW SAMPLING
PROCEDURES**

FIGURE 2

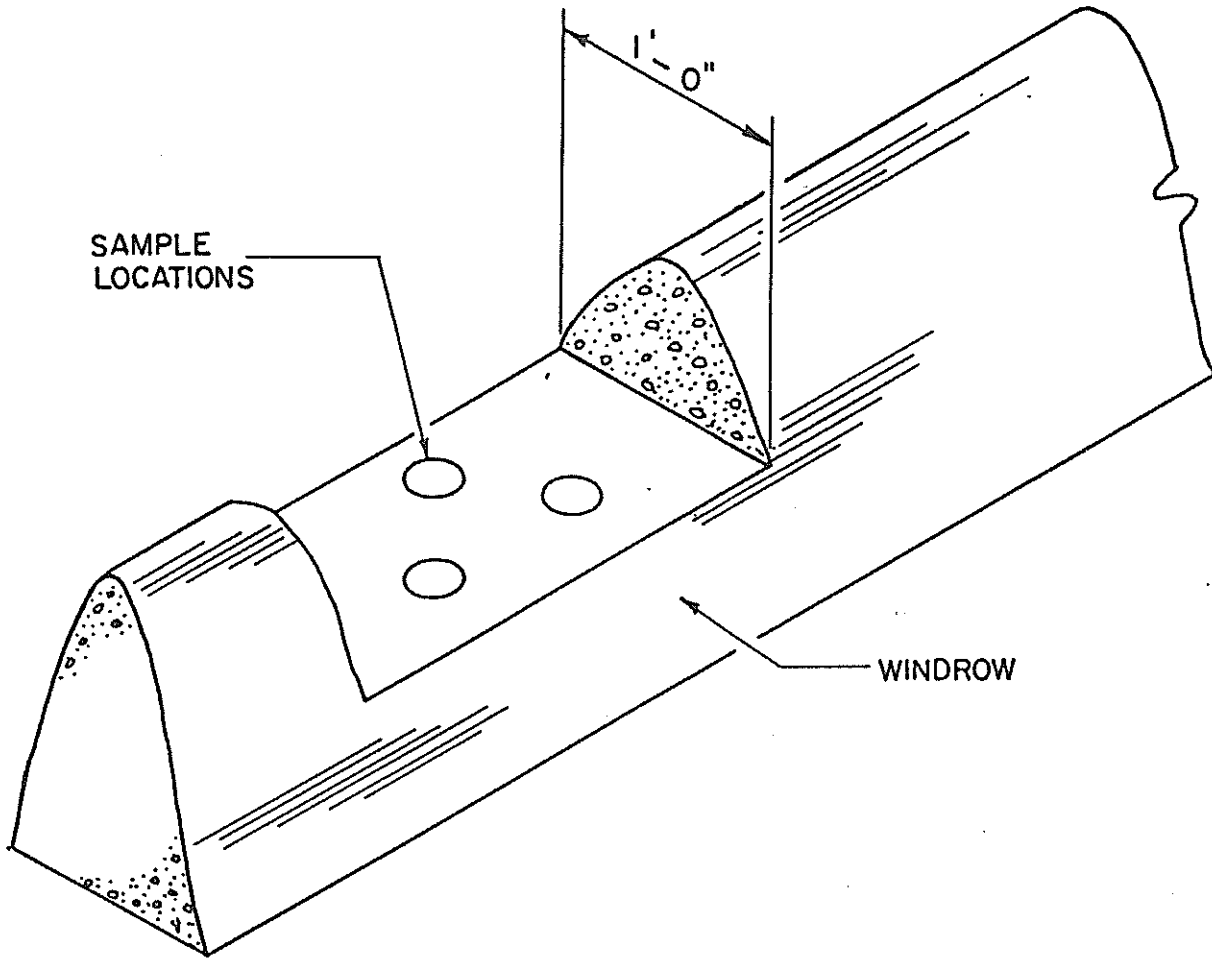

FLATTEN WINDROW TO ABOUT ONE FOOT IN WIDTH. DIG MATERIAL FROM AT LEAST THREE RANDOM LOCATIONS AS SHOWN. MIX INTO ONE SAMPLE, THEN SPLIT DOWN TO REQUIRED SIZE FOR TEST.

METHOD 4

WINDROW SAMPLING PROCEDURES

FIGURE 3

5. SHIPPING SAMPLES

5.1 Transport aggregates in bags or other containers so constructed as to preclude loss or contamination of any part of the sample, or damage to the contents from mishandling during shipment.

5.2 Shipping containers for aggregate samples shall have suitable individual identification attached and enclosed so that field reporting, laboratory logging, and test reporting may be facilitated.

TABLE 1 Size of Samples

Maximum Nominal Size of Aggregates ^A		Approximate Minimum Mass of Field Samples, kg ^B (lb)
Fine Aggregate		
2.36mm	(No. 8)	5(10)
4.75mm	(No. 4)	5(10)
Coarse Aggregate		
9.5 mm	(3/8 in.)	5(10)
12.5 mm	(1/2 in.)	10(20)
19.0 mm	(3/4 in.)	15(30)
25.0 mm	(1 in.)	25(50)
37.5 mm	(1-1/2 in.)	30(70)
50 mm	(2 in.)	40(90)
63 mm	(2-1/2 in.)	45(100)
75 mm	(3 in.)	60(125)
90 mm	(3-1/2 in.)	65(150)

^AFor processed aggregate the maximum nominal size of particles is the largest sieve size listed in the applicable specification, upon which any material is permitted to be retained.

^BFor combined coarse and fine aggregates (for example, base or subbase) minimum weight shall be coarse aggregate minimums plus 10 kg (25 lb.).

APPENDIX X
NONMANDATORY INFORMATION

X1. SAMPLING AGGREGATE FROM STOCKPILES OR TRANSPORTATION UNITS

X1.1 Scope

X1.1.1 In some situations it is mandatory to sample aggregates that have been stored in stockpiles or loaded into rail cars, barges, or trucks. In such cases the procedure should ensure that segregation does not introduce a serious bias in the results.

X1.2 Sampling From Stockpiles

X1.2.1 In sampling material from stockpiles it is very difficult to ensure unbiased samples, due to the segregation which often occurs when material is stockpiled, with coarser particles rolling to the outside base of the pile. For coarse or mixed coarse and fine aggregate, every effort should be made to enlist the services of power equipment to develop a separate, small sampling pile composed of materials drawn from various levels and locations in the main pile after which several increments may be combined to compose the field sample. If necessary to indicate the degree of variability existing within the main pile, separate samples should be drawn from separate areas of the pile.

X1.2.2 Where power equipment is not available, samples from stockpiles should be made up of at least three increments taken from the top third, at the midpoint, and at the bottom third of the volume of the pile. A board shoved vertically into the pile just above the sampling point aids in preventing further segregation (see Figure 3). In sampling stockpiles of fine aggregate, the outer layer, which may have become segregated, should be removed and the sample taken from the material beneath. Sampling tubes approximately 30 mm (1-1/4 in.) min by 2 m (6 ft.) min in length may be inserted into the pile in the top third, at the midpoint, and in the bottom third locations to extract a minimum of three increments of material to form the sample (see Figure 4).

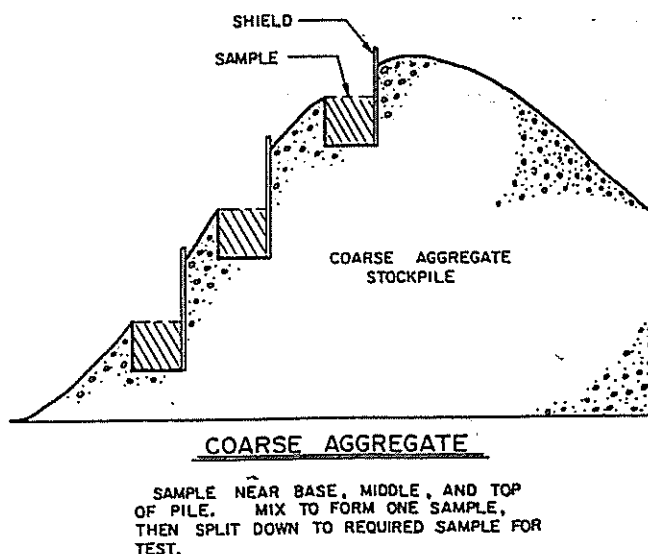
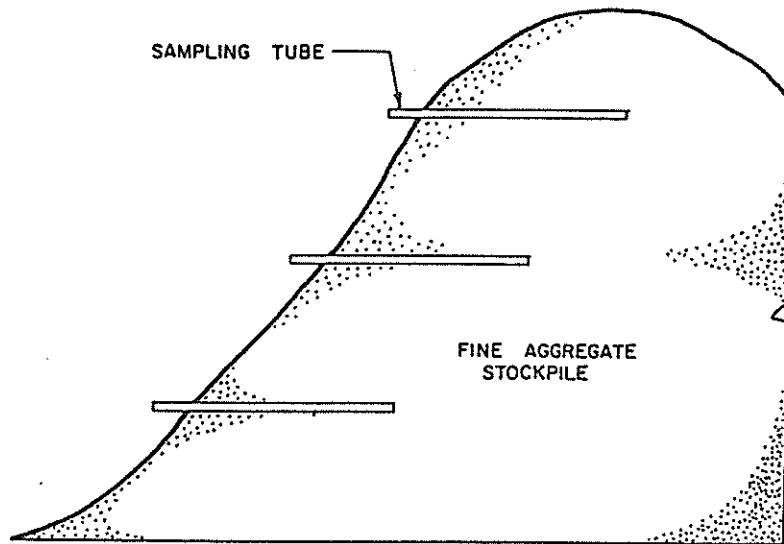

FIGURE 4



FINE AGGREGATE

INSERT TUBE HORIZONTALLY NEAR BASE, MIDDLE, AND TOP OF PILE. MIX THE THREE SAMPLES, THEN SPLIT TO REQUIRED SAMPLE FOR TESTING.

FIGURE 5

X1.3 Sampling From Transportation Units

X1.3.1 In sampling coarse aggregates from railroad cars or barges, effort should be made to enlist the services of power equipment capable of exposing the material at various levels and random locations. Where power equipment is not available, a common procedure requires excavation of an area of approximately 1 m² (9 sq. ft.) The excavated area should be approximately level, at least 1.0 m (3 ft.) in width and at least 0.3 m (1 ft.) in depth below the surface. A minimum of three increments from the excavated area should be taken by pushing a shovel or scoop downward into the material. Coarse aggregate in trucks should be sampled in essentially the same manner as for rail cars or barges. For fine aggregate in transportation units, sampling tubes as described in Section X1.2 may be used to extract a minimum of three increments to form the sample.

X2. EXPLORATION OF POTENTIAL AGGREGATE SOURCES

X2.1 Scope

X2.1.1 Sampling for evaluation of potential aggregate sources should be performed by a responsible, trained and experienced person. Because of the wide variety of conditions under which sampling may have to be done, it is not possible to describe detailed procedures applicable to all circumstances. This appendix is intended to provide general guidance and list more comprehensive references.

X2.2 Sampling Stone From Quarries or Ledges

X2.2.1 Inspection - The ledge or quarry face should be inspected to determine discernible variations or strata. Differences in color and structure should be recorded.

X2.2.2 Sampling and Size of Sample - Separate samples having a mass of at least 25 kg. (approximately 50 lbs) should be obtained from each discernible stratum. The sample should not include material weathered to such an extent that it is no longer suitable for the purpose intended. One or more pieces in each sample should be at least 150 by 150 by 100 mm (6 by 6 by 4 in.) in size with the bedding plane plainly marked, and this piece should be free of seams or fractures.

X2.2.3 Record - In addition to the general information accompanying all samples, the following information should accompany samples taken from ledges or quarry faces:

X2.2.3.1 Approximate quantity available. (If quantity is very large this may be recorded as practically unlimited.)

X2.2.3.2 Quantity and character of overburden.

X2.2.3.3 A detailed record showing boundaries and location of material represented by each sample.

Note X2.1 - A sketch, plan, and elevation, showing the thickness and location of the different layers, is recommended for this purpose.

X2.3 Sampling Roadside or Bank Run Sand and Gravel Deposits

X2.3.1 Inspection - Potential sources of bank run sand and gravel may include previously worked pits from which there is an exposed face or potential deposits discovered through air-photo interpretation, geophysical exploration, or other types of terrain investigation.

X2.3.2 Sampling - Samples should be so chosen from each different stratum in the deposit discernible to the sampler. An estimate of the quantity of the different materials should be made. If the deposit is worked as an open-face bank or pit, samples should be taken by channeling the face vertically, bottom to top, so as to represent the materials proposed for use. Overburden or disturbed material should not be included in the sample. Test holes should be excavated or drilled at numerous locations in the deposit to determine the quality of the material and the extent of the deposit beyond the exposed face, if any. The number and depth of test holes will depend upon the quantity of the material needed, topography of the area, nature of the deposit, character of the material, and potential value of the material in the deposit. If visual inspection indicates that there is considerable variation in the material, individual samples should be selected from the material in each well defined stratum. Each sample should be thoroughly mixed and quartered if necessary so that the field sample thus obtained will be at least 12 kg (25 lbs.) for sand and 35 kg (75 lbs.) if the deposit contains an appreciable amount of coarse aggregate.

X2.3.3 Record - In addition to the general information accompanying all samples, the following information should accompany samples of bank run sand and gravel:

X2.3.3.1 Location of supply,

X2.3.3.2 Estimate of approximate quantity available,

X2.3.3.3 Quantity and character of overburden,

X2.3.3.4 Length of haul to proposed site of work,

X2.3.3.5 Character of haul (kind of road, maximum grades, etc.), and

X2.3.3.6 Details as to extent and location of material represented by each sample.

Note X2.2 - A sketch of plans and elevations, showing the thickness and location of different layers, is recommended for this purpose.

Standard Method of Test for

Amount of Material Finer Than 75 μm (No. 200) Sieve in Aggregate WFLHD Designation: T 11-94 (Modified AASHTO T 11)

1. SCOPE

1.1 This method covers determination of the amount of material finer than a 75 μm (No. 200) sieve in aggregate by washing. Clay particles and other aggregate particles that are dispersed by the wash water, as well as water-soluble materials, will be removed from the aggregate during the test.

2. APPLICABLE DOCUMENTS

2.1 AASHTO Standards:

M 92 Wire Cloth Sieves for Testing Purposes

T 2 Sampling Aggregates

T 27 Sieve Analysis of Fine and Coarse Aggregates

T 248 Reducing Field Samples of Aggregate to Testing Size

3. SUMMARY OF METHOD

3.1 A sample of the aggregate is washed in a prescribed manner and the decanted wash water containing suspended and dissolved material is passed through a 75 μm (No. 200) sieve. The loss in weight resulting from the wash treatment is calculated as weight percent of the original sample and is reported as the percentage of material finer than a 75 μm (No. 200) sieve by washing.

4. SIGNIFICANCE AND USE

4.1 Material finer than the 75 μm (No. 200) sieve can be separated from larger particles much more efficiently and completely by wet sieving than through the use of dry sieving. Therefore, when accurate determinations of material finer than 75 μm in fine or coarse aggregate are desired, this method is used on the sample prior to dry sieving in accordance with AASHTO T 27. The results of this test are included in the calculation in AASHTO T 27, and the total amount of material finer than 75 μm by washing plus that obtained by dry sieving the same sample, is reported with the results of AASHTO T 27. Usually the additional amount of material finer than 75 μm obtained in the dry sieving process is a small amount. If it is large, the efficiency of the washing operation should be checked. It could also be an indication of degradation of the aggregate.

5. APPARATUS

5.1 Balance - The balance shall conform to the requirements of AASHTO M 231 for the class of general purpose balance required for the principal sample weight of the sample being tested.

5.2 Sieves - A nest of two sieves, the lower being a 75 μ m (No. 200) sieve and the upper being in the range of 2.36 mm (No. 8) to 1.18 mm (No. 16), both conforming to the requirements of M 92.

5.3 Container - A pan or vessel of a size sufficient to contain the sample covered with water and to permit vigorous agitation without loss of any part of the sample or water.

5.4 Oven - An oven of sufficient size, capable of maintaining a uniform temperature of 110 \pm 5 C (230 \pm 9 F).

Note 1 - The use of a mechanical apparatus to perform the washing operation is not precluded, provided the results are consistent with those obtained using manual operations. The use of some mechanical washing equipment with some samples may cause degradation of the sample.

6. SAMPLING

6.1 Sample the aggregate in accordance with AASHTO T 2. If the same test sample is to be tested for sieve analysis according to AASHTO T 27, comply with the applicable requirements of that method.

6.2 Thoroughly mix the sample of aggregate to be tested and reduce the quantity to an amount suitable for testing using the applicable methods described in AASHTO T 248. If the same test sample is to be tested according to AASHTO T 27, the minimum weight shall be as described in the applicable sections of that method. Otherwise, the weight of the test sample, after drying, shall conform with the following:

<u>Nominal Maximum Size</u>	<u>Minimum Weight, g</u>
2.36 mm (No. 8)	100
4.75 mm (No. 4)	500
9.5 mm (3/8 in.)	1000
19.0 mm (3/4 in.)	2500
37.5 mm (1-1/2 in.) or larger	5000

The test sample shall be the end result of the reduction. Reduction to an exact predetermined weight shall not be permitted.

7. PROCEDURE

7.1 Dry the test sample to constant weight at a temperature of 110 \pm 5 C (230 \pm 9 F) and weigh to the nearest 0.1 percent of the weight of the sample. AASHTO T 255 provides a method by which elevated drying temperatures may be used.

7.2 If the applicable specification requires that the amount passing the 75 μ m (No. 200) sieve shall be determined on a portion of the sample passing a sieve smaller than the nominal maximum size of the aggregate, separate the sample on the designated sieve and weigh the material passing the designated sieve to 0.1 percent of the weight of this portion of the test sample. Use this weight as the original dry weight of the test sample in 8.1.

Note 2 - Some specifications for aggregates with a nominal maximum size of 50 mm or greater, for example, provide a limit for material passing the 75 μ m (No. 200) sieve determined on that portion of the sample passing the 25.0 mm sieve. Such procedures are necessary since it is impractical to wash

samples of the size required when the same test sample is to be used for sieve analysis by AASHTO T 27.

7.3 After drying and weighing, place the test sample in the container and add sufficient water to cover it. A detergent, dispersing agent, or other similar substance may be added to the water. Agitate the sample with sufficient vigor to result in complete separation of all particles finer than the 75 μ m (No. 200) sieve from the coarser particles, and to bring the fine material into suspension. Immediately pour the wash water containing the suspended and dissolved solids over the nested sieves, arranged with the coarser sieve on top. Take care to avoid, as much as feasible, the decantation of coarser particles of the sample.

7.4 Add a second charge of water to the sample in the container, agitate, and decant as before. Repeat this operation until the wash water is clear.

Note 3 - If mechanical washing equipment is used, the charging of water, agitating, and decanting may be a continuous operation.

7.5 Return all material retained on the nested sieves by flushing to the washed sample. Dry the washed aggregate to constant weight at a temperature of 110 \pm 5 C (230 \pm 9 F) and weigh to the nearest 0.1 percent of the original weight of the sample. AASHTO T 255 provides a method by which elevated drying temperatures may be used.

8. CALCULATION

8.1 Calculate the amount of material passing a 75 μ m (No. 200) sieve by washing as follows:

$$A = [(B - C)/B] \times 100$$

Where:

A = percentage of material finer than a 75 μ m (No.200) sieve by washing.

B = original dry weight of sample, g, and

C = dry weight of sample after washing, g.

9. REPORT

9.1 Report the percentage of material finer than the 75 μ m (No.200) sieve by washing to the nearest 0.1 percent.

10. PRECISION

10.1 The multilaboratory standard deviation has been found to be 0.22 percent for nominal 19.0 mm (3/4 in.) maximum size coarse aggregate with less than 1.5 percent passing the 75 μ m (No.200) sieve. Therefore, results of two

properly conducted tests from different laboratories on samples of the same coarse aggregate should not differ by more than 0.62 percent. The corresponding single-operator standard deviation has been found to be 0.10 percent. Therefore, results of two properly conducted tests by the same operator on the same coarse aggregate should not differ by more than 0.28 percent.

Note 4 - These numbers represent, respectively, the (1S) and (D2S) limits as described in ASTM Recommended Practice C 670.

Standard Method of Test for

Making and Curing Concrete Test Specimens in the Field In Concrete Finishing and Handling Equipment WFLHD Designation: T 23-94 (Modified AASHTO T 23)

1. SCOPE

1.1 This method covers procedures for making and curing cylindrical and prismatic specimens using job concrete that can be consolidated by rodding or vibration as described herein.

Note 1 - For making and curing test specimens in the laboratory, see AASHTO T 126.

1.2 The molded specimens shall have the same levels of slump, air content, and percentage of coarse aggregate as the concrete being placed in the work.

2. APPLICABLE DOCUMENTS

2.1 AASHTO Standards:

T 119 Slump of Portland Cement Concrete

T 126 Making and Curing Concrete Test Specimens in the Laboratory

T 141 Sampling Freshly Mixed Concrete

T 159 Air Content of Freshly Mixed Concrete by the Pressure Method

T 196 Air Content of Freshly Mixed Concrete by the Volumetric Method

T 231 Capping Cylindrical Concrete Specimens

M 201 Moist Cabinets, Moist Rooms, and Water Storage Tanks Used in the Testing of Hydraulic Cements and Concretes

M 205 Molds for Forming Concrete Test Cylinders Vertically

3. APPARATUS

3.1 **Molds, General** - Molds for specimens or fastenings thereto in contact with the concrete shall be made of steel, cast iron, or other nonabsorbent material, nonreactive with concrete containing portland or other hydraulic cements. Molds shall hold their dimensions and shape under conditions of severe use. Molds shall be watertight during use as judged by their ability to hold water poured into them. Provisions for tests of watertightness are given in Section 6 of AASHTO M 205. A suitable sealant, such as heavy grease, modeling clay, or microcrystalline wax shall be used where necessary to prevent leakage through the joints. Positive means shall be provided to hold base plates firmly to the molds. Molds shall be lightly coated with mineral oil or a suitable nonreactive form release material before use.

3.2 Cylinder Molds:

3.2.1 Molds for Casting Specimens Vertically - Molds for casting concrete test specimens shall conform to the requirements of AASHTO M 205.

3.3 Beam Molds - Beam molds shall be rectangular in shape and of the dimensions required to produce the specimens stipulated in Section 5.2. The inside surfaces of the molds shall be smooth. The sides, bottom, and ends shall be at right angles to each other and shall be straight and true and free of warpage. Maximum variation from the nominal cross-section shall not exceed 3.175 mm (1/8 in.) for molds with depth or breadth of 152.4 mm (6 in.) or more. Molds shall produce specimens not more than 1.5875 mm (1/16 in.) shorter than the required length in accordance with Section 5.2, but may exceed it by more than that amount.

3.4 Tamping Rods - Two sizes are specified. Each shall be a round, straight, steel rod with at least the tamping end rounded to a hemispherical tip of the same diameter as the rod. Both ends may be rounded if preferred.

3.4.1 Large Rod - 15.875 mm (5/8 in.) in diameter and approximately 609.6 mm (24 in.) long.

3.4.2 Small Rod - 9.525 mm (3/8 in.) in diameter and approximately 304.8 mm (12 in.) long.

3.5 Vibrators - Internal vibrators may have rigid or flexible shafts, preferably powered by electric motors. The frequency of vibration shall be 7,000 vibrations per minute or greater while in use. The outside diameter or side dimension of the vibrating element shall be at least 19.05 mm (0.75 in.) and not greater than 38.1 mm (1.50 in.). The combined length of the shaft and vibrating element shall exceed the maximum depth of the section being vibrated by at least 76.2 mm (3 in.). When external vibrators are used, they should be the table or plank type. The frequency of external vibrators shall be at least 3,600 vibrations per minute. For both table and plank vibrators, provision shall be made for clamping the mold securely to the apparatus. A vibrating-reed tachometer should be used to check the frequency of vibration.

3.6 Mallet - A mallet with a rubber or rawhide head weighing 0.568 ± 0.227 kg (1.25 ± 0.50 lb.) shall be used.

3.7 Small Tools - Tools and items which may be required are shovels, pails, trowels, wood float, metal float, blunted trowels, straightedge, feeler gage, scoops, and rules.

3.8 Slump Apparatus - The apparatus for measurement of slump shall conform to the requirements of AASHTO T 119.

3.9 Sampling and Mixing Receptacle - The receptacle shall be a suitable heavy gage metal pan, wheelbarrow, or flat, clean nonabsorbent mixing board of sufficient capacity to allow easy remixing of the entire sample with a shovel or trowel.

3.10 Air Content Apparatus - The apparatus for measuring air content shall conform to the requirements of AASHTO T 196 or AASHTO T 152.

4. SAMPLING CONCRETE

4.1 The samples used to fabricate test specimens under this standard shall be obtained in accordance with AASHTO T 141 unless an alternative procedure has been approved.

4.2 Record the identity of the sample with respect to the location of the concrete represented and the time of casting.

5. TEST SPECIMENS

5.1 **Compressive Strength Specimens** - Compressive strength specimens shall be cylinders of concrete cast and hardened in an upright position, with a length equal to twice the diameter. The standard specimen shall be the 152.4 by 304.8 mm (6 by 12 in.) cylinder when the maximum size of the coarse aggregate does not exceed 50 mm (2 in.). When the maximum size of the coarse aggregate does exceed 50 mm (2 in.), either the concrete sample shall be treated by wet sieving as described in AASHTO T 141 or the diameter of the cylinder shall be at least three times the nominal maximum size of coarse aggregate in the concrete. When the nominal maximum size of the coarse aggregate does not exceed 25.4 mm (1 in.), the specimens may be 101.6 by 203.2 mm (4 by 8 in.) cylinders.

Note 2 - The maximum size is the smallest sieve opening through which the entire amount of aggregate is required to pass.

5.2 **Flexural Strength Specimens** - Flexural strength specimens shall be rectangular beams of concrete cast and hardened with long axes horizontal. The length shall be at least 50.8 mm (2 in.) greater than three times the depth as tested. The ratio of width to depth as molded shall not exceed 1.5. The standard beam shall be 152.4 by 152.4 mm (6 by 6 in.) in cross section, and shall be used for concrete with maximum size coarse aggregate up to 50.8 mm (2 in.). When the nominal maximum size of the coarse aggregate exceeds 50.8 mm (2 in.), the smaller cross sectional dimension of the beam shall be at least three times the nominal maximum size of the coarse aggregate. Unless required by project specifications, beams made in the field shall not have a width or depth of less than 152.4 mm (6 in.).

6. MOLDING SPECIMENS

6.1 **Placing of Molds** - Mold specimens promptly on a level, rigid, horizontal surface, free from vibration and other disturbances, at a place as near as practicable to the location where they are to be stored. Immediately after being struck off, the specimens shall be moved to the storage place where they will remain undisturbed for the initial curing period. If specimens made in single use mold are moved, lift and support the specimens from the bottom of the molds with a trowel or other device.

6.2 **Placing the Concrete** - Place the concrete in the molds using a scoop, blunted trowel, or shovel. Select each scoopful, trowelful, or shovelful of concrete from the mixing pan to ensure that it is representative of the batch. Remix the concrete in the mixing pan with a shovel or trowel to prevent segregation during the molding of specimens. Move the scoop, trowel, or shovel around the perimeter of the mold opening when adding concrete to ensure an even distribution of the concrete and minimize segregation. Further distribute the

concrete by use of a tamping rod prior to the start of consolidation. In placing the final layer, the operator shall attempt to add an amount of concrete that will exactly fill the mold after compaction. Do not add nonrepresentative concrete to an underfilled mold.

6.2.1 Number of Layers - Make specimens in layers as indicated in Table 1.

6.3 Consolidation:

6.3.1 Methods of Consolidation - Preparation of satisfactory specimens requires different methods of consolidation. The methods of consolidation are rodding, and internal or external vibration. Base the selection of the method of consolidation on the slump, unless the method is stated in the specifications under which the work is being performed. Rod concretes with a slump greater than 76.2 mm (3 in.). Rod or vibrate concretes with slump of 25.4 to 76.2 mm (1 to 3 in.). Vibrate concretes with slump of less than 25.4 mm (1 in.). Concretes of such low water content that they cannot be properly consolidated by the methods described herein, or requiring other sizes and shapes of specimens to represent the product or structure, are not covered by this method. Specimens for such concretes shall be made in accordance with the requirements of AASHTO T 126 with regard to specimen size and shape; and method of consolidation.

6.3.2 Rodding - Place the concrete in the mold, in the required number of layers of approximately equal volume. For cylinders, rod each layer with the rounded end of the rod using the number of strokes specified in Table 2. The number of roddings per layer required for beams is one for each $1,290.32 \text{ mm}^2$ (2 in.^2) top surface area of the specimen. Rod the bottom layer throughout its depth. Distribute the strokes uniformly over the cross section of the mold and for each upper layer allow the rod to penetrate about 13 mm (1/2 in.) into the underlying layer when the depth of the layer is less than 101.6 mm (4 in.) and about 25 mm (1 in.) when the depth is 101.6 mm (4 in.) or more. If voids are left by the tamping rod, tap the sides of the mold lightly with the mallet or open hand when using light-gage single-use molds to close the voids. After each layer is rodded, spade the concrete along the sides and ends of beam molds with a trowel or other suitable tool.

6.3.3 Vibration - Maintain a uniform time period for duration of vibration for the particular kind of concrete, vibrator, and specimen mold involved. The duration of vibration required will depend upon the workability of the concrete and the effectiveness of the vibrator. Usually, sufficient vibration has been applied as soon as the surface of the concrete has become relatively smooth. Continue vibration only long enough to achieve proper consolidation of the concrete. Overvibration may cause segregation. Fill the molds and vibrate in the required number of approximately equal layers. Place all the concrete for each layer in the mold before starting vibration of that layer. When placing the final layer, avoid overfilling by more than 6.35 mm (1/4 in.).

Finish the surface either during or after vibration where external vibration is used. Finish the surface after vibration when internal vibration is used. When the finish is applied after vibration, add only enough concrete with a trowel to overfill the mold about 3 mm (1/8 in.). Work it into the surface and then strike it off.

**Table 1
Number of Layers Required for Specimens**

Specimen Type and Size, as Depth, mm (in.)	Mode of Compaction	Number of Layers	Approximate Depth of Layer, mm (in.)
Cylinders:			
Up to 304.8 (12)	Rodding	3 equal	---
Over 304.8 (12)	Rodding	as required	101.6 (4)
304.8 (12) to 457.2 (18)	Vibration	2 equal	Half depth of specimen
Over 457.2 (18)	Vibration	3 or more	203.2 (8) as near as practicable
Beam:			
6 (150) to 8 (200)	Rodding	2 equal	Half depth of specimen
Over 8 (200)	Rodding	3 or more	101.6 (4)
6 (150) to 8 (200)	Vibration	1	Depth of specimen
Over 8 (200)	Vibration	2 or more	203.2 (8) as near as practicable

**Table 2
Diameter of Rod and Number of Roddings to be
Used in Molding Cylinder Test Specimens**

Diameter of Cylinder, mm (in.)	Diameter of Rod, mm (in.)	Number of Strokes/Layer
101.6 (4)	9.525 (3/8)	25
152.4 (6)	15.875 (5/8)	25
203.2 (8)	15.875 (5/8)	50
254.0 (10)	15.875 (5/8)	75

6.3.3.1 Internal Vibration - The diameter of the vibrating element, or thickness of a square vibrating element, shall be in accordance with the requirements of Section 3.5. For beams, the vibrating element shall not exceed 1/3 of the width of the mold. For cylinders, the ratio of the diameter of the cylinder to the diameter of the vibrating element shall be 4.0 or higher. In compacting the specimen, the vibrator shall not be allowed to rest on the bottom or sides of the mold. Carefully withdraw the vibrator in such a manner that no air pockets are left in the specimen. After vibration of each layer, tap the sides of the mold with the mallet to ensure removal of large entrapped air bubbles.

6.3.3.2 Cylinders - Use three insertions of the vibrator at different points for each layer. Allow the vibrator to penetrate through the layer being vibrated, and into the layer below, approximately 25 mm (1 in.).

6.3.3.3 Beam - Insert the vibrator at intervals not exceeding 152.4 mm (6 in.) along the centerline of the long dimension of the specimen. For specimens wider than 152.4 mm (6 in.), use alternating insertions along two lines. Allow the shaft of the vibrator to penetrate into the bottom layer approximately 25 mm (1 in.).

6.3.4 External Vibration - When external vibration is used, take care to ensure that the mold is rigidly attached to or securely held against the vibrating element or vibrating surface.

6.4 Finishing - After consolidation, unless the finishing has been performed during the vibration (Section 6.3.3), strike off the surface of the concrete and float or trowel it as required. Perform all finishing with the minimum manipulation necessary to produce a flat even surface that is level with the rim or edge of the mold and that has no depressions or projections larger than 3.175 mm (1/8 in.).

6.4.1 Cylinders - After consolidation, finish the top surfaces by striking them off with the tamping rod where the consistency of the concrete permits or with a wood float or trowel. If desired, cap the top surface of freshly made cylinders with a thin layer of stiff portland cement paste which is permitted to harden and cure with the specimen. See section on Capping Materials in AASHTO T 231.

6.4.2 Beams - Beams shall be finished with a wood or metal float.

7. SLUMP AND AIR CONTENT

7.1 Slump - Measure the slump of each batch of concrete, from which specimens are made, immediately after remixing in the receptacle, as required in AASHTO T 119.

7.2 Air Content - Determine the air content in accordance with either AASHTO T 152 or AASHTO T 196. The concrete used in performing the air content test shall not be used in fabricating test specimens.

8. CURING

8.1 Covering After Finishing - To prevent evaporation of water from the unhardened concrete, cover the specimens immediately after finishing, preferably with a nonabsorptive, nonreactive plate or a sheet of tough, durable, impervious plastic. Wet burlap may be used for covering, but care must be exercised to keep the burlap wet until the specimens are removed from the molds. Placing a sheet of plastic over the burlap will facilitate keeping it wet. Protect the outside surfaces of cardboard molds from all contact with wet burlap or other sources of water for the first 24 h after cylinders have been molded in them. Water may cause the molds to expand and damage specimens at this early age.

8.2 Initial Curing - During the first 24 h after molding, store all test specimens under conditions that maintain the temperature immediately adjacent to the specimens in the range of 15.6 to 26.7 C (60 to 80 F) and prevent loss of moisture from the specimens. Storage temperatures may be regulated by means of ventilation or by evaporation of water from sand or burlap, or by using heating devices such as stoves, electric light bulbs, or thermostatically controlled

heating cables. A temperature record of the specimens may be established by means of maximum-minimum thermometers. Store specimens in tightly constructed, firmly braced wooden boxes, damp sand pits, temporary buildings at construction sites, under wet burlap in favorable weather, or in heavyweight closed plastic bags, or use other suitable methods, provided the foregoing requirements limiting specimen temperature and moisture loss are met. Specimens formed in cardboard molds (Section 3.2.1) shall not be stored for the first 24 h in contact with wet sand or wet burlap or under any other condition that will allow the outside surfaces of the mold to absorb water.

Note 3 - The temperature within damp sand and under wet burlap or similar materials will always be lower than the temperature in the surrounding atmosphere if evaporation takes place.

8.3 Curing Cylinders for Checking the Adequacy of Laboratory Mixture Proportions for Strength or as the Basis for Acceptance or for Quality Control - Remove test specimens made for checking the adequacy of the laboratory mixture proportions for strength, or as the basis for acceptance, from the molds at the end of 20 ± 4 h and store in a moist condition at 15.6 to 26.7 C (60 to 80 F) until the moment of test, except test specimens that must be shipped to a laboratory may, at the option of the engineer, be shipped in the mold in a manner meeting the requirements of Section 9. As applied to the treatment of demolded specimens, moist curing means that the test specimens shall have free water maintained on the entire surface area at all times. This condition is met by immersion in saturated lime water and may be met by storage in a moist room or cabinet meeting the requirements of AASHTO M 201. Specimens shall not be exposed to dripping or running water.

8.4 Curing Cylinders for Determining Form Removal Time or When a Structure May be Put into Service - Store test specimens made for determining when forms may be removed or when a structure may be put in service in or on the structure as near to the point of use as possible. Specimens shall receive, insofar as practicable, the same protection from the elements on all surfaces as is given to the portions of the structure which they represent. Test the specimens in the moisture condition resulting from the specified curing treatment. To meet these conditions, specimens made for the purpose of determining when a structure may be put in service shall be removed from the molds at the time of removal of form work. Follow the provisions of Section 8.6, where applicable, for removal of specimens from molds.

8.5 Curing Beams for Checking the Adequacy of Laboratory Mixture Proportions for Strength or as the Basis for Acceptance or for Quality Control - Remove test specimens made for checking the adequacy of the laboratory mixture proportions for flexural strength, or as the basis for acceptance, or for quality control, from the mold between 20 and 48 h after molding and cure according to the provisions of Section 8.3 except that storage for a minimum period of 20 h immediately prior to testing shall be in saturated lime water at 16 to 27 C (60 to 80 F). At the end of the curing period, between the time the specimen is removed from curing until testing is completed, prevent drying of the surfaces of the specimen.

Note 4 - Relatively small amounts of drying of the surface of flexural specimens induce tensile stresses in the extreme fibers that will markedly reduce the indicated flexural strength.

8.6 Curing Beams for Determining When a Structure May be Put into Service - Cure test specimens for determining when a structure may be put into service, as nearly as practicable, in the same manner as the concrete in the structure. At the end of 48 ± 4 h after molding, take the specimens in the molds to a location preferably near a field laboratory and remove from the molds. Store specimens representing pavements or slabs on grade by placing them on the ground as molded, with their top surfaces up. Bank the sides and ends of the specimens with earth or sand that shall be kept damp, leaving the top surfaces exposed to the specified curing treatment. Store specimens representing structure concrete as near the point in the structure they represent as possible and afford them the same temperature protection and moisture environment as the structure. At the end of the curing period, leave the specimens in place exposed to the weather in the same manner as the structure. Remove all beam specimens from field storage and store in lime water at 15.6 to 26.7 C (60 to 80 F) for 24 ± 4 h immediately before time of testing to ensure uniform moisture condition from specimen to specimen. Observe the precautions given in Section 8.5 to guard against drying between time of removal from curing to testing.

9. TRANSPORTATION OF SPECIMENS TO LABORATORY

9.1 Specimens shall not be transported from the field to the laboratory before completion of the initial curing. Specimens to be transported prior to an age of 48 h shall not be demolded prior to completion of transportation. Prior to transporting, specimens must be protected as required in Section 8. During transportation, the specimens shall be cured and protected with suitable cushioning material to prevent damage from jarring and from damage by freezing temperatures, or moisture loss. Moisture loss may be prevented by wrapping the specimens in plastic or surrounding them with wet sand or wet sawdust. When specimens are received by the laboratory, they shall be removed from molds if applicable, and shall be placed immediately in a condition so as to continue curing required by Section 8.3 for demolded specimens.

Standard Method of

Obtaining and Testing Drilled Cores and Sawed Beams of Concrete or Asphaltic Pavements WFLHD Designation: T 24-94 (Modified AASHTO T 24)

1. SCOPE

1.1 This method covers the procedures for obtaining, preparing, and testing (a) cores drilled from concrete for length or compressive or splitting tensile strength determinations and (b) beams sawed from concrete for flexural strength determinations. This method also covers the procedures for obtaining (a) cores drilled from asphaltic pavements, and (b) slabs obtained from asphaltic pavements.

2. APPARATUS

2.1 Core Drill - For obtaining cylindrical core specimens. For all specimens to be removed by drilling a diamond drill shall be used.

2.2 Saw - For cutting beam specimens to size or for obtaining asphaltic pavement slabs. The saw shall have a diamond or silicon-carbide cutting edge and shall be capable of cutting specimens which conform to the prescribed dimensions, without excessive heating or shock.

2.3 Jackhammer - When obtaining asphaltic pavement slabs a jackhammer equipped with a 75 to 150 mm (3 to 6 in.) spade or chisel head may be used in lieu of a saw. When using a jackhammer, the required sample size dimensions shall be increased by at least 50 mm (2 in.).

3. SAMPLING

3.1 General - Samples of hardened concrete for use in the preparation of strength test specimens shall not be taken until the concrete has become hard enough to permit sample removal without disturbing the bond between the mortar and the coarse aggregate. In general, the concrete shall be 14 days old before the specimens are removed. When preparing strength test specimens from samples of hardened concrete, samples that show abnormal defects or samples that have been damaged in the process of removal shall not be used. Core and slab samples taken from asphaltic pavements shall be taken after the mix has cooled sufficiently to allow coring, sawing, or jackhammering without altering or distorting the sample.

3.1.1 Specimens containing embedded reinforcement shall not be used for determining splitting tensile strength and specimens for determining flexural strength shall not be used if reinforcement is embedded in the tensile portion of the specimen.

Note 1 - Cores for determining compressive strength that contain embedded reinforcement can yield either higher or lower values than cores without embedded steel and should be avoided if possible or trimmed to eliminate the reinforcement provided an L/D of 1.00 or greater can be attained.

3.2 Core Drilling - A core specimen taken perpendicular to a horizontal surface shall be located, when possible, so that its axis is perpendicular to the bed of the concrete or asphaltic pavement as originally placed and not near formed joints or obvious edges of a unit of deposit. A specimen taken perpendicular to a vertical surface, or perpendicular to a surface with a batter, shall be taken from near the middle of a unit of deposit when possible and not near formed joints or obvious edges of a unit of deposit.

3.3 Slab Removal - Remove a slab sufficiently large to secure the desired test specimens without the inclusion of any concrete or asphaltic pavement which has been cracked, spalled, undercut, or otherwise damaged.

DRILLED CORES

4. LENGTH OF DRILLED CORE SPECIMENS

4.1 Length of Specimens - A core specimen for the determination of length shall have a diameter of at least 100 mm (4 in.).

4.2 Procedure for Length Determination - Measure the length of concrete pavement cores in accordance with the provisions of AASHTO T 148, Measuring Length of Drilled Concrete Cores. Measure the length of asphaltic pavement cores in accordance with FLH T 501, Determining The Thickness or Height of Compacted Asphalt Paving Mixture Specimens.

5. COMPRESSIVE STRENGTH

5.1 Test Specimens - The diameters of concrete core specimens for the determination of compressive strength should be at least 3 times the maximum nominal size of the coarse aggregate used in the concrete and must be at least twice the maximum nominal size of the coarse aggregate. The length of the specimen, when capped, shall be as nearly as practicable twice its diameter. A core having a maximum height of less than 95 percent of its diameter before capping or a height less than its diameter after capping shall not be tested.

5.2 End Preparation - The ends of concrete core specimens to be tested in compression shall be essentially smooth, perpendicular to the longitudinal axis, and of the same diameter as the body of the specimen. If necessary, saw or tool the ends of the specimens until the following requirements are met:

5.2.1 Projections, if any, shall not extend more than 5 mm (0.2 in.) above the end surfaces,

5.2.2 The end surfaces shall not depart from perpendicularity to the longitudinal axis by more than 5 deg., and

5.2.3 The diameter of the ends shall not depart more than 2.5 mm (0.1 in.) (2.5 mm) from the mean diameter of the specimen.

5.3 Moisture Conditioning - Submerge the concrete test specimens in lime-saturated water at 23 ± 1.7 C (73.4 ± 3.0 F) for at least 40 hours immediately prior to making the compression test. Test the specimens promptly after removal from water storage. During the period between removal from water storage and

testing, keep the specimens moist by covering with a wet blanket or burlap or other suitable absorbent fabric.

Note 2 - When the agency for which the testing is being done so directs, cores may be tested in a moisture condition other than that achieved by soaking for at least 40 hours. Length-diameter correction factors shown in 5.7 are applicable to both dry and soaked concrete. Direction for consideration of testing in moisture conditions other than that achieved by soaking at least 40 hours may be found in ACI 301, Chapter 17 and ACI 318, Chapter 4.

5.4 Capping - Before making the compression test, cap the ends of the specimens in conformance with the procedure prescribed in the applicable section of AASHTO T 231, Capping Cylindrical Concrete Specimens. The capped surfaces of the specimens shall conform to the planeness requirements of T 231.

5.4.1 Neoprene Caps - The use of neoprene caps or pads may be used in lieu of high strength gypsum plaster or sulfur mortar, for capping the ends of the specimens. The neoprene caps should not be attached to the specimen but should be inserted between the ends of the specimen and the bearing surfaces of the test apparatus. See AASHTO T 22.

5.5 Measurement - Prior to testing, measure the length of the capped specimen (or uncapped specimen when using neoprene caps) to the nearest 2.5 mm (0.1 in.) and use this length to compute the length-diameter ratio. Determine the average diameter by averaging two measurements taken at right angles to each other about the mid-height of the specimen. Measure core diameters to the nearest 0.25 mm (0.01 in.) whenever possible, but at least to the nearest 2.5 mm (0.1 in.).

5.6 Testing - Test the specimens in accordance with the applicable provision of AASHTO T 22, Test for Compressive Strength of Molded Concrete Cylinders.

5.7 Calculations - Calculate the compressive strength of each specimen using the computed cross-sectional area based on the average diameter of the specimen. If the ratio of length to diameter of the specimen is appreciably less than two, make allowance for the ratio of length to diameter by multiplying the compressive strength by the applicable correction factor as follows:

Ratio of Length of Cylinder to Diameter L/D	Strength Correction Factor*
1.75	0.98
1.50	0.96
1.25	0.93
1.00	0.87

* These correction factors apply to lightweight concrete weighing between 1600 and 1920 kg/m³ (100 and 120 lb/ft³) and to normal weight concrete. They are applicable to concrete dry or soaked at the time of loading. Values not given in the table shall be determined by interpolation. The correction factors are applicable for nominal concrete strengths from 13.8 to 41.4 MPa (2000 to 6000 psi). (Correction factors depend on various conditions such as strength and elastic moduli. Average values are given in the table.)

5.8 Report - Report the results as required by AASHTO T 22 with the addition of the following information:

5.8.1 Length of test specimen before and after capping,

5.8.2 Compressive strength to the nearest 69 kPa (10 psi) when the diameter is measured to the nearest 0.25 mm (0.01 in.), and to the nearest 345 kPa (50 psi) when the diameter is measured to the nearest 2.5 mm (0.1 in.), after correction for length-diameter ratio when required,

5.8.3 Direction of application of the load on the specimen with respect to the horizontal plane of the concrete as placed,

5.8.4 The moisture condition at the time of testing, and

5.8.5 Nominal maximum size of concrete aggregate.

6. SPLITTING TENSILE STRENGTH

6.1 Test Specimens - The specimens shall conform to the dimensional requirements in 5.1, 5.2.1, and 5.2.2. Ends are not to be capped.

6.2 Moisture Conditioning - Prior to testing the specimens shall be conditioned as described in 5.3.

6.3 Bearing Surfaces - The line of contact between the specimen and each bearing strip shall be straight and free of any projections or depressions higher or deeper than 0.25 mm (0.01 in.). When the line of contact is not straight or contains projections or depressions having heights or depths greater than 0.25 mm (0.01 in.), the specimen shall be ground or capped so as to produce bearing lines meeting these requirements, except that specimens with projections or depressions greater than 2.5 mm (0.1 in.) shall not be used. When capping is employed, the caps shall be as thin as practicable and shall be formed of high-strength gypsum plaster.

Note 4 - Figure 1 illustrates a device that has been found convenient for applying caps to 150 mm (6 in.) diameter specimens.

6.4 Testing - Test specimens in accordance with the applicable provisions of AASHTO T 198, Test for Splitting Tensile Strength of Concrete Cylinders.

6.5 Calculation and Report - Calculate the splitting tensile strength and report the results as required in T 198. When grinding or capping of the bearing surfaces is required, the diameter shall be measured between the finished surfaces. Indicate that the specimen was a core and state its moisture condition at the time of testing.

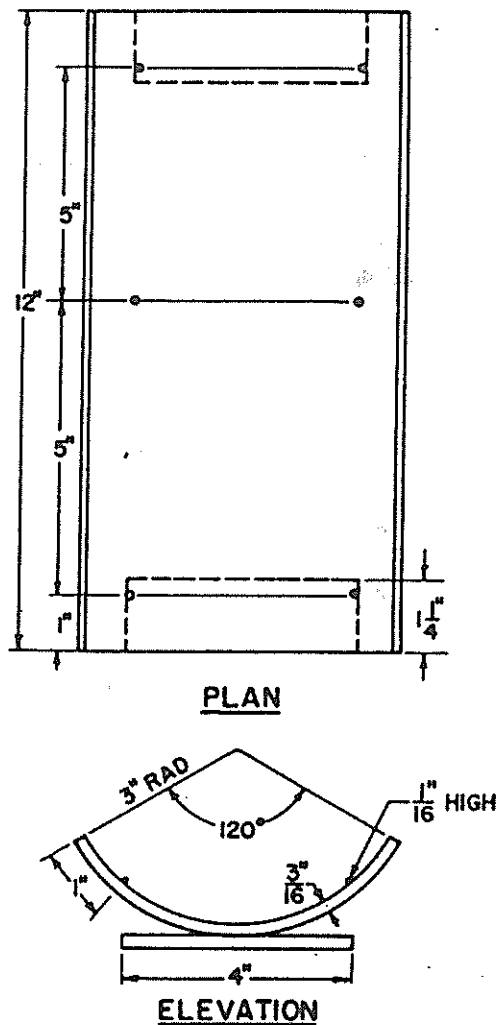

Metric Equivalents

in.	1/16	3/16	1	1-1/4	3	4	5	12
mm	1.6	4.8	25	32	76	102	127	305

FIG. 1 Suitable Capping Device for Splitting Tensile Strength Test.

SAWED BEAMS

7. FLEXURAL STRENGTH

7.1 Test Specimens - A beam specimen for the determination of flexural strength shall in general have a cross-section of 150 x 150 mm (6 by 6 in.). The specimen shall be at least 533 mm (21 in.) in length, but when two tests for flexural strength are to be made on one beam specimen, it shall be at least 838 mm (33 in.) (838 mm) in length. Perform the sawing operation so that the concrete will not be weakened by shock or by heating. The sawed surfaces shall be smooth, plane, parallel, and free from steps, ridges, and grooves. Take care in handling sawed beam specimens to avoid chipping or cracking.

Note 5 - In many cases, particularly with prisms cut from pavement slabs, the width will be governed by the size of the coarse aggregate and the depth by the thickness of the slab.

7.2 Moisture Conditioning - Submerge the test specimens in lime-saturated water at 23 ± 1.7 C (73.4 ± 3.0 F) for at least 40 hours immediately prior to the flexure test. Test the specimens promptly after removal from water storage. During the period between removal from water storage and testing, keep the specimens moist by covering with a wet blanket of burlap or other suitable absorbent fabric. Relatively small amounts of drying of the surface of flexural specimens induce tensile stresses in the extreme fibers that will markedly reduce the indicated flexural strength.

Note 6 - When the agency for which the testing is being done so directs, beams may be tested in a moisture condition other than that achieved by soaking for at least 40 hours.

7.3 Testing - Test the specimens in accordance with the applicable provisions of AASHTO T 97, Test for Flexural Strength of Concrete (Using Simple Beam with Third-Point Loading).

Note 7 - The compressive strengths of portions of beams broken in flexure may be determined by testing such portions as modified cubes in accordance with AASHTO T 140, Test for Compressive Strength of Concrete Using Portions of Beams Broken in Flexure (Modified Cube Method).

Note 8 - Sawing may greatly reduce the indicated flexural strength. Beams shall, therefore, be tested with a molded surface in tension whenever possible. The location of the tension face with respect to the position of the concrete as placed and the position of the sawed surfaces should be reported.

7.4 Report - Report the results in accordance with the applicable provisions of AASHTO T 97 and the requirements of this method, including the moisture condition at the time of testing.

Standard Method of Test for
Sieve Analysis of Fine and Coarse Aggregates
WFLHD Designation: T 27-94 (Modified AASHTO T 27)

1. SCOPE

1.1 This method covers the determination of the particle size distribution of fine and coarse aggregates by sieving.

1.2 Some specifications for aggregates which reference this method contain grading requirements including both coarse and fine fractions. Instructions are included for sieve analysis of such aggregates.

1.3 The values stated in acceptable units (SI units and units specifically approve RI for use with SI units) are regarded as the standard. The values in parentheses as provided for information purposes only.

1.4 This standard may involve hazardous materials, operations, and equipment. This standard does not purport to address all of the safety problems associated with its use. It is the responsibility of whoever uses this standard to consult established appropriate safety and health practices and determine the applicability of regulatory regulations prior to use.

2. APPLICABLE DOCUMENTS

2.1 AASHTO Standards:

M 92 Wire Cloth Sieves for Testing Purposes

RI Metric Practice

T 2 Sampling Aggregates

T 11 Amount of Material Finer than .075 mm Sieve in Aggregate

T 248 Reducing Field Samples of Aggregate to Testing Size

2.2 ASTM Standards:

C 670 Practice for Preparing Statements for Test Methods for Construction Materials.

3. SUMMARY OF METHOD

3.1 A weighed sample of dry aggregate is separated through a series of sieves of progressively smaller openings for determination of particle size distribution.

4. SIGNIFICANCE AND USE

4.1 This method is used primarily to determine the grading of materials proposed for use as aggregates or being used as aggregates. The results are used to determine compliance of the particle size distribution with applicable

specification requirements and to provide necessary data for control of the production of various aggregate products and mixtures containing aggregates. The data may also be useful in developing relationships concerning porosity and packing.

4.2 Accurate determination of material finer than the 75 μ m (No. 200) sieve cannot be achieved by use of this method alone. Test Method T 11 for material finer than 75 μ m sieve by washing should be employed.

5. APPARATUS

5.1 Balance - The balance shall conform to the requirements of AASHTO M 231 for the class of general purpose balance required for the principal sample weight of the sample being tested.

5.2 Sieves - The sieves shall be mounted on substantial frames constructed in a manner that will prevent loss of material during sieving. Suitable sieve sizes shall be selected to furnish the information required by the specifications covering the material to be tested. The sieves shall conform to M 92. Sieves with openings larger than 125 mm (5 in.) shall have a permissible variation in average opening of \pm 2 percent and shall have a nominal wire diameter of 8.0 mm (5/16 in.) or larger.

Note 1 - It is recommended that sieves mounted in frames larger than standard 203 mm (8 in.) diameter frames be used for testing coarse aggregate.

5.3 Mechanical Sieve Shaker - A mechanical sieve shaker, if used, shall impart a vertical, or lateral and vertical, motion to the sieve, causing the particles thereon to bounce and turn so as to present different orientations to the sieving surface. The sieving action shall be such that the criterion for adequacy of sieving described in Section 7.4 is met in a reasonable time period.

Note 2 - Use of a mechanical sieve shaker is recommended when the size of the sample is 20 kg or greater, and may be used for smaller samples, including fine aggregate. Excessive time (more than approximately 10 min) to achieve adequate sieving may result in degradation of the sample. The same mechanical sieve shaker may not be practical for all sizes of samples, since the large sieving area needed for practical sieving of a large nominal size coarse aggregate very likely could result in loss of a portion of the sample if used for a smaller sample of coarse aggregate or fine aggregate.

5.4 Oven - An oven of appropriate size capable of maintaining a uniform temperature of 110 \pm 5 $^{\circ}$ C (230 \pm 9 $^{\circ}$ F).

6. SAMPLING

6.1 Sample the aggregate in accordance with T 2. The weight of the field sample shall be the weight shown in T 2 or four times the weight required in 6.4 and 6.5 (except as modified in 6.6), whichever is greater.

6.2 Thoroughly mix the sample and reduce it to an amount suitable for testing using the applicable procedures described in T 248. The sample for test shall be approximately of the weight desired when dry and shall be the end result of the reduction. Reduction to an exact predetermined weight shall not be permitted.

Note 3 - Where sieve analysis, including determination of material finer than the 75µm sieve, is the only testing proposed, the size of the sample may be reduced in the field to avoid shipping excessive quantities of extra material to the laboratory.

6.3 **Fine Aggregate** - The test sample of the aggregate shall weigh, after drying, approximately the following amount:

- Aggregate with at least 95 percent passing a 2.36 mm (No. 8) sieve 100 g
- Aggregate with at least 85 percent passing a 4.75 mm (No. 4) sieve and more than 5 percent retained on a 2.36 mm (No. 8) sieve 500g

6.4 **Coarse Aggregate** - The weight of the test sample of coarse aggregate shall conform with the following:

Nominal Maximum Size Square Openings, mm (in.)	Minimum Weight of Test Sample, kg (lb.)
9.5 (3/8)	1 (2)
12.5 (1/2)	2 (4)
19.0 (3/4)	5 (11)
25.0 (1)	10 (22)
37.5 (1-1/2)	15 (33)
50 (2)	20 (44)
63 (2-1/2)	35 (77)
75 (3)	60 (130)
90 (3-1/2)	100 (220)
100 (4)	150 (330)
112 (4-1/2)	200 (440)
125 (5)	300 (660)
150 (6)	500 (1100)

6.5 **Coarse and Fine Aggregate Mixtures** - The weight of the test sample of coarse and fine aggregate mixtures shall be the same as for coarse aggregate in Section 6.4.

6.6 The size of sample required for aggregates with large nominal maximum size is such as to preclude testing except with the large mechanical sieve shakers. However, the intent of this method will be satisfied for samples of

aggregate larger than 50 mm nominal maximum size if a smaller weight of sample is used, provided that the criterion for acceptance or rejection of the material is based on the average of results of several samples, such that the sample size used times the number of samples averaged equals the minimum weight of sample shown in Section 6.4.

6.7 In the event that the amount of material finer than the 75 μ m (No. 200) sieve is to be determined by T 11, proceed as follows:

6.7.1 For aggregates with a nominal maximum size of 12.5 mm (1/2 in.) or less, use the same test sample for testing T 11 and this method. First test the sample in accordance with T 11 through the final drying operation, then dry sieve the sample as stipulated in 7.2 through 7.7 of this method.

6.7.2 For aggregates with a nominal maximum size greater than 12.5 mm (1/2 in.), a single test sample may be used as described in 6.7.1 or separate test samples may be used for T 11 and this method.

6.7.3 Where the specifications require determination of the total amount of material finer than 75 μ m (No. 200) sieve by washing and dry sieving, use the procedure described in 6.7.1.

7. PROCEDURE

7.1 Dry the sample to constant weight at a temperature of 110 \pm 5° C (230 \pm 9° F).

Note 4 - For control purposes, particularly where rapid results are desired, it is generally not necessary to dry coarse aggregate for the sieve analysis test. The results are little affected by the moisture content unless (1) the nominal maximum size is smaller than about 12.5 mm (1/2 in.); (2) the coarse aggregate contains appreciable material finer than 4.75 mm (No. 4) or (3) the coarse aggregate is highly absorptive (a lightweight aggregate for example). Also, samples may be dried at the higher temperature associated with the use of hot plates without affecting results, provided steam escapes without generating pressures sufficient to fracture the particles and temperatures are not so great as to cause chemical breakdown of the aggregate.

7.2 Suitable sieve sizes shall be selected which furnish the information required by the specifications covering the material to be tested. The use of additional sieves may be desirable to provide other information such as fineness modulus, or to regulate the amount of material on a sieve. Nest the sieves in order of decreasing size of opening from top to bottom and place the sample on the top sieve. Agitate the sieves by hand or by mechanical apparatus for a sufficient period, established by trial or checked by measurement on the actual test sample, to meet the criterion for adequacy or sieving described in Section 7.4.

7.3 Limit the quantity of material on a given sieve so that all particles have opportunity to reach sieve openings a number of times during the sieving operation. For sieves with openings smaller than the 4.75 mm (No. 4), the weight retained on any sieve at the completion of the sieving operation shall not exceed 6 kg/m² (4 g/in.²) of sieving surface. For sieves with openings 4.75 mm

(No. 4) and larger, the weight in kg/m² of sieving surface shall not exceed the product of 2.5 x (sieve opening in mm). In no case shall the weight be so great as to cause permanent deformation of the sieve cloth. (See Table 2 on page T27-22W).

Note 5 - The 6 kg/m² amounts to 195 g for the usual 203 mm (8 in.) diameter sieve. The amount of material retained on a sieve may be regulated by (1) the introduction of a sieve with larger openings immediately above the given sieve or (2) using the sample in a number of increments.

7.4 Continue sieving for a sufficient period and in such manner that, after completion, not more than 0.5 percent by weight of the total sample passes any sieve during 1 minute of continuous hand sieving performed as follows: Hold the individual sieve, provided with a snug-fitting pan and cover, in a slightly inclined position in one hand. Strike the side of the sieve sharply and with an upward motion against the heel of the other hand at the rate of about 150 times per minute, turn the sieve about one sixth of a revolution at intervals of about 25 strokes. In determining sufficiency of sieving for sizes larger than the 4.75 mm (No. 4) sieve, limit the material on the sieve to a single layer of particles. If the size of the mounted testing sieves makes the described sieving motion impractical, use 203 mm (8 in.) diameter sieves to verify the sufficiency of sieving.

7.5 In the case of coarse and fine aggregate mixtures, the portion of the sample finer than the 4.75 mm (No. 4) sieve may be distributed among two or more sets of sieves to prevent overloading of individual sieves.

7.5.1 Alternatively, the portion finer than the 4.75 mm (No. 4) sieve may be reduced in size using a mechanical splitter according to T 248. If this procedure is followed, compute the weight of each size increment of the original sample as follows:

$$A = \frac{W_1}{W_2} X B$$

Where:

A = weight of size increment on total sample basis.

W₁ = weight of fraction finer than a 4.75 mm (No. 4) sieve in total sample,

W₂ = weight of reduced portion of material finer than 4.75 mm (No. 4) sieve actually sieved, and

B = weight of size increment in reduced portion sieved.

7.6 Unless a mechanical sieve shaker is used, hand sieve particles larger than 75 mm (3 in.) by determining the smallest sieve opening through which each particle will pass. Start the test on the smallest sieve to be used. Rotate the particles, if necessary, in order to determine whether they will pass through a particular opening; however, do not force particles to pass through an opening.

7.7 Determine the weight of each size increment by weighing on a scale or balance conforming to the requirements specified in Section 5.1 to the nearest 0.1 percent of the total original dry sample weight. The total weight of the material after sieving should check closely with original weight of sample placed on the sieves. If the amounts differ by more than 0.3 percent based on the original dry sample weight, the results should not be used for acceptance purposes.

7.8 If the sample has previously been tested by T 11, add the weight finer than the 75 μ m (No. 200) sieve determined by that method to the weight passing the 75 μ m (No. 200) sieve by dry sieving of the same sample in this method.

8. CALCULATION

8.1 Calculate percentages passing, total percentages retained, or percentages in various size fractions to the nearest 0.1 percent on the basis of the total weight of the initial dry sample. If the same test sample was first tested by T 11, include the weight of material finer than the 75 μ m (No. 200) sieve by washing in the sieve analysis calculation; and use the total dry sample weight prior to washing in T 11 the basis for calculating all the percentages.

8.2 Calculate the fineness modulus, when required, by adding the total percentages of material in the sample that is coarser than each of the following sieves (cumulative percentages retained), and dividing the sum by 100: 150 μ m (No.100), 300 μ m (No.50), 600 μ m (No. 30), 1.18 mm (No.16), 2.36 mm (No. 8), 4.75 mm (No. 4), 9.5 mm (3/8 in.), 19.0 mm (3/4 in.), 37.5 mm (1-1/2 in.), and larger, increasing the ratio of 2 to 1.

9. REPORT

9.1 Depending upon the form of the specifications for use of the material under test, the report shall include the following:

- 9.1.1 Total percentage of material passing each sieve, or
 - 9.1.2 Total percentage of material retained on each sieve, or
 - 9.1.3 Percentage of material retained between consecutive sieves.
- 9.2 Report percentages to the nearest 0.1 percent.
- 9.3 Report the fineness modulus, when required, to the nearest 0.01.

10. PRECISION

10.1 The estimates of precision of this method listed in Table 1 are based on results from the AASHTO Materials Reference Laboratory Reference Sample Program with testing conducted by this method. While there are differences in the minimum weight of the test sample required for other nominal maximum sizes of aggregate, no differences entered into the testing to affect the determination of these precision indices. The data are based on the analyses of more than 100 paired test results from 40 to 100 laboratories. The values in the table are given for different ranges of percentage of aggregate passing one sieve and retained on the next finer sieve.

Table 1 Precision

	: % of Size Fraction : Between Consecutive : Sieves	: Coefficient of : Variation : (1S %), % ^B	: of : Standard : Deviation : (1S), % ^A	: Acceptable Range : of Test Results : (D2S %) ^B : % of Avg.: (D2S), % ^A
Coarse Aggregates:^C				
Single-Operator Precision	: 0 to 3 : 3 to 10 : 10 to 20 : 20 to 50	: 30 ^D	: : 1.4 ^D : 0.95 : 1.38	: 85 ^D : : 4.0 ^D : 2.7 : 3.9
Multi-Laboratory Precision	: 0 to 3 : 3 to 10 : 10 to 20 : 20 to 30 : 30 to 40 : 40 to 50	: 35 ^D	: : 1.06 : 1.66 : 2.01 : 2.44 : 3.18	: 99 ^D : : 3.0 : 4.7 : 5.7 : 6.9 : 9.0
Fine Aggregates:				
Single-Operator Precision	: 0 to 3 : 3 to 10 : 10 to 20 : 20 to 30 : 30 to 40 : 40 to 50		: 0.14 : 0.43 : 0.60 : 0.64 : 0.71 :	: 0.4 : 1.2 : 1.7 : 1.8 : 2.0 :
Multi-Laboratory Precision	: 0 to 3 : 3 to 10 : 10 to 20 : 20 to 30 : 30 to 40 : 40 to 50		: 0.21 : 0.57 : 0.95 : 1.24 : 1.41 :	: 0.6 : 1.6 : 2.7 : 3.5 : 4.0 :

^A These numbers represent, respectively, the (1S) and (D2S) as described in ASTM C 670.
^B These numbers represent, respectively, the (1S %) and (D2S %) limits as described in ASTM C 670.
^C The precision estimates are based on coarse aggregates with nominal maximum size of 19.0 mm (3/4 in.).
^D These values are from precision indices first included in T 27. Other indices were developed in 1982 from more recent AASHTO Materials Reference Laboratory sample data, which did not provide sufficient information to revise the values as noted.

**Instructions for Sieve Analysis -
AASHTO T 27, SUPPLEMENTAL INSTRUCTIONS**

1. SCOPE

These instructions cover the normally required sieve analysis and an abbreviated sieve analysis. Only the normal sieve analysis fulfills the testing requirements for statistical acceptance of aggregate. Both methods provide for drying and/or washing only a portion of the original field sample, and will provide test results with a minimum of testing time.

The abbreviated sieve analysis may be used for nonstatistical acceptance of aggregates. However, enough washed samples, normal sieve analysis, must be run to determine what effect fines clinging to other particles will have on the total sieve analysis. The type and degree of testing can be determined by the specifications, engineering needs, and judgment. Even when the 75 μ m (No. 200) sieve is not a specification, the 75 μ m (No. 200) minus material (clinging to coarse or fine aggregate) may influence proper acceptance or rejection of borderline aggregates.

2. GENERAL

The specifications require that samples be taken by the contractor in the presence of the engineer, and that the contractor provide and maintain sampling facilities. Contractor furnished FIELD SAMPLE sizes are set forth in T 2, TESTING SAMPLE sizes for sieve analysis in T 27, and for washing in T 11.

The following sample sizes (weight of dried aggregate) are taken from the above referenced Sections, represent the base aggregate gradings normally specified, and meet the requirements for sample size under T 2, T 11, and T 27 as approved for use in this Region.

Reference	Maximum Particle Size	
	50 mm (2")	25 mm (1")
Minimum FIELD SAMPLE size, AASHTO T 2 (Modified for gradation only)	41,000 g (90 lbs.)	23,000 g (50 lbs.)
Minimum TEST SAMPLE size, AASHTO T 27	20,000 g (44 Lbs.)	10,000 g (22 Lbs.)
Minimum size for washing coarse, AASHTO T 11	5,000 g (11 Lbs.)	3,600 g (8 Lbs.)
Minimum size for washing fine, AASHTO T 11	500 g (1.1 Lbs.)	500 g (1.1 Lbs.)

Note a: Samples of aggregate for bituminous mixtures shall be of a size meeting the above references when tested for gradation prior to the addition of bitumen. Sample size for gradation of extracted aggregate is approximately 2,500 grams as set forth in AASHTO T 164 of this Manual.

Basically two types of samples are run in the field laboratory, samples for information and samples for acceptance. Both will normally require splitting before testing which is covered in T 248.

INFORMATION samples are normally taken at the crusher, contain only natural moisture, and are ready for splitting and testing.

ACCEPTANCE samples usually will contain optimum moisture for compaction and may require partial drying before splitting and testing. The sample may contain 6 to 7 percent moisture and should be carefully dried to around 4 percent or less. This partial drying should be controlled to prevent overdrying (or at least overdrying on part of the sample) which may cause fines to be "cooked" onto the coarse particles.

If heat in excess of 60°C (140°F) degrees F will be used for partial drying, a portion of the field sample should be quartered-out for S.E., L.L., and P.I. testing before partial drying is started. Excess moisture will not affect this quartering, and the portion can then be dried at low temperature to a moisture content around 4 percent or less before test specimens are prepared.

3. NORMAL SIEVE ANALYSIS

It is assumed at this point in these instructions that a 40 kg (90 lb.) plus sample of aggregate has been obtained, that it is at a suitable moisture content for sieving, and that temperatures in excess of 60°C (140°F) were not used to get the sample in this condition.

Step #1. The large square sieves furnished will not accommodate a 40 kg (90 lb.) sample, therefore, separate the total sample into at least two random portions. The nested sieves should contain all those listed in the specification plus whatever intermediate sizes may be necessary to eliminate the overloading of any sieve.

Shake the first portion through the nested sieves. Separate the sieves and place the material retained from each sieve in a separate container. Then shake the second portion through the nested sieves. Weigh the material retained on each specification sieve size, combining material from both sieving operations, and record the individual weights in Column 1 "WT. WET." The material from the pan, both sieving operations, should be set aside, and will be discussed in Step #3. The material retained on the 4.75 mm (No. 4) and larger sieves may be combined, and will be discussed in Step #2.

Note b: Coarse sieves [4.75 mm (No. 4) and larger] are overloaded when the particles are more than one deep, and fine sieves can handle about 4 grams per square inch or about 200 grams for an eight inch sieve.

Note c: Intermediate sieves are not necessarily reported by themselves, but combined with and reported as being retained on the next smaller specification sieve.

Note d: Shake the material in the nested sieves for a few minutes, stop the shaker and observe the fines clinging to the coarse particles. Shake again for a few minutes and then observe. Five to six minutes total shaking time should be sufficient to separate the particles such that clinging fines will not change the weight on any sieve by more than 1%. Normally, hand brushing of coarse particles will not be necessary. However, oversieving to remove clinging fines should be prevented. This is a matter of judgment.

Step #2. Recombine the coarse aggregate (CA) material developed in Step #1 and retained on the 4.75 mm (No. 4) sieve, and split-out two portions weighing approximately (but not less than) 5 kg (11 lbs.) Excess material may be set aside. Weigh one of the 5 kg (11-lb.) portions, record the weight as "Wt. Wet Aggre." in Column 2, and place it under the infrared oven for drying. The remaining 5 kg (11-lb.) portion will be discussed under Step #5.

Note e: Samples for "MOISTURE TEST" should be dried to constant weight at a temperature not exceeding 230°C (450°F).

Step #3. Take the fine aggregate (FA) material passing the 4.75 mm (No. 4) sieve developed in Step #1 and split-out two portions weighing approximately (but not less than) 500 grams. Weigh one of the 500 gram portions, record the weight as "Wt. Wet Aggr." in Column 3, and place it under the infrared oven for drying. The remaining portion will be discussed in Step #4.

Note f: If portions have not been set aside for S.E., L.L., and P.I. previously, they may now be taken since the total sample has not been exposed to temperatures in excess of 60°C (140°F).

Step #4. Take the remaining 500 gram portion of FA from Step #3, weigh, and record the weight as "Wt. Wet Aggr." in Column 4. Then proceed to wash the portion in accordance with AASHTO T 11. Washing in a coffee pot or similar vessel resting on nested sieves has been found a quick and efficient method for small samples. Do not be concerned about the P-75 μm (P-200) minus material that is lost with the washing water. Combine the FA from the vessel and nested sieves and place them under the dryer.

Step #5. Take the 5 kg (11-lb.) portion of CA set aside in Step #2, weigh, and record the weight as "Wt. Wet Aggr." in Column 5. Then proceed to wash in accordance with AASHTO T 11. Combine the CA from the vessel and nested sieves and place it under the dryer.

Step #6. At this point there should be four samples or portions under the infrared dryer. As they dry, treat them as follows:

From Step #2 - weigh the CA and record as "Wt. Dry Aggr." in Column 2.

From Step #3 - weigh the FA and record as "Wt. Dry Aggr." in Column 3.

From Step #4 - weigh the FA and record as "Wt. Washed Dry Aggr." in Column 4. Then shake the material through nested fine sieves (specification and intermediate as outlined in Step #1). Record the individual weights of the "DRY NO. 4.75mm (No.4) MINUS" in Column 6.

From Step #5 - weigh the CA and record as "Wt. Washed Dry Aggr." in Column 5. Then shake the material through a large 4.75 mm (No. 4) sieve (because of the quantity that will be retained thereon) and then through nested fine sieves. Record the individual weights of "WASHED FROM COARSE" in Column 7.

At this point the physical testing is complete and the remainder of Form WDFD-247 can be completed by computations.

4. COMPUTATIONS, NORMAL SIEVE ANALYSIS

Step #7. In the block "MOISTURE," the "Wt. of Water" equals the "Wt. Wet Aggre." less the "Wt. Dry Aggr.," and the "Percent of Moisture" (percent of the dry aggregate) equals the "Wt. of Water" divided by the "Wt. Dry Aggr."

Step #8. In the block P-75 μ m "(P-200) WASH," the "Wt. Dry Aggr." equals the "Wt. Wet Aggr." divided by the "Percent of Moisture" expressed as a decimal plus one (e.g. 740.0 divided by 1.057 = 700.09 or 700.1); and the "Wt. P-75 μ m (P-200)" equals the "Wt. Dry Aggr." less the "Wt. Washed Dry Aggr." At this point, the "Wt. P-75 μ m (P-200)" should also be entered in Columns 7 & 6 as the "Wt. P-75 μ m (P-200)." Now add the "Pan" and "Wt. P-75 μ m (P-200)" to find the "Total P-75 μ m (P-200)."

Step #9. Complete the coarse aggregate analysis as follows: The "Wt. Wet" values in Column 1 are converted to "Wt. Dry" by dividing them by 1.0 plus the "Percent of Moisture" expressed as a decimal (e.g. $3.12 \div 1.031 = 3.026$ or 3.03).

The "%" retained in all blocks equals the "Wt. Dry" divided by the "Total Sample Wt."

Step #10. The "PERCENT PASSING" in all blocks is found by subtracting the "%" retained on the largest sieve from 100%. Subsequent values are found by subtracting each "%" retained from the previous "PERCENT PASSING."

Step #11. Under "DRY 4.75 mm (NO. 4) MINUS" the "PASSING," the 4.75 mm ("No. 4") sieve is the "RETAINED %" from above, and subsequent values are a percentage of this value (e.g. $45.2 \times 65.7 = 29.7$).

Step #12. Under "WASHED FROM COARSE," the "PASSING" is equal to 1.0 less the "RETAINED %" from above expressed as a decimal (e.g. $1.0 \text{ less } .452 = .548 \times 9.2 = 5.04$ or 5.0), and so forth.

Step #13. The "TOTAL % PASSING" for the coarse fraction was found in Step #10. For the fine fraction, it is the sum of the "PASSING" columns.

5. ABRIDGED SIEVE ANALYSIS

Step #1A. Shake the sample through nested sieves as in Step #1, and record the results in Column 1.

Step #2A. Recombine the CA as in Step #2, split-out one 5 kg (11-lb.) \pm portion, weigh it, record the weight in Column 2, and place it in the infrared oven to dry.

Step #3A. Take the FA from Step #1A and split-out one 500-gram \pm portion, weigh it, record the weight in Column 3, and place it under the dryer.

Step #4A. When the CA dries, weigh the portion and record as "Wt. Dry Aggr." in Column 2.

Step #5A. When the FA dries, weigh and record the weight as "Orig. Dry Wt." in Column 6. Next, shake the sample through fine nested sieves and record the results in Column 6. This completes the physical testing.

6. COMPUTATIONS, ABRIDGED SIEVE ANALYSIS

Make computations as set forth in Steps #7, #9, #10, and #11.



****NORMAL SIEVE ANALYSIS****

**WORKSHEET FOR SIEVE ANALYSIS OF FINE AND COARSE AGGREGATE
AASHTO T 11 AND AASHTO T 27**

Project _____ Source _____ Sample No. _____

Sample of _____ Quantity represented _____ Lot No. _____

Sampled by _____ Date _____ Tested by _____ Date _____

MOISTURE DETERMINATION			PERCENT PASSING NO. 200 SIEVE (P-200) WASH		
Moisture content	Coarse ②	Fine ③	P-200 content	Coarse ⑤	Fine ④
Weight of wet aggregate	14.18	680.7	Weight of wet aggregate	13.40	740.0
Weight of dry aggregate	13.75	644.0	Weight of dry aggregate	13.00	700.1
Weight of water	0.43	36.7	Weight of washed dry aggregate	12.88	635.1
Moisture (%)	3.1	5.7	Weight of P-200	0.12	65.0

REMARKS:	Coarse Aggregate Sieve size	① Retained			Total Passing (%)	Spec's
		Wt Wet	Wt Dry	%		
	inch					
	2 inch	0	0	0	100	
	1 1/2 inch	3.12	3.03	3.3	96.7	
	1 inch	8.98	8.71	9.4	87.3	
	1/2 inch	19.31	18.73	20.2	67.1	
	inch					
	No. 4	20.89	20.26	21.9		
	No. 4 minus	44.20	41.82	45.2		
	Total sample Wt	96.50	92.55			

Fine Aggregate Sieve size	WASHED FROM COARSE				DRY NO. 4 MINUS				Total Passing (%)	Spec's
	⑦ Retained		Percent Passing	Adjusted (%) Passing	⑥ Retained		Percent Passing	Adjusted (%) Passing		
	Wt. Dry	%				Wt Dry			%	
No. 4	11.80	90.8	9.2	5.0	0	0	100	45.2	50.2	
No. 10	0.34	2.6	6.6	3.6	240.4	34.3	65.7	29.7	33.3	
No. 40	0.50	3.8	2.8	1.5	214.6	30.7	35.0	15.8	17.3	
No. 100	0.06	0.5	2.3	1.2	85.5	12.2	22.8	10.3	11.5	
No. 200	0.10	0.8	1.5	0.8	89.5	12.8	10.0	4.5	5.3	
Pan	0.08				4.3					
Wt. P-200	0.12				65.0					
Total P-200	0.20	1.5			69.3	10.0				
Orig. Dry Wt.	13.00				699.3					



**WORKSHEET FOR SIEVE ANALYSIS OF FINE AND COARSE AGGREGATE
AASHTO T 11 AND AASHTO T 27**

Project _____ Source _____ Sample No. _____

Sample of _____ Quantity represented _____ Lot No. _____

Sampled by _____ Date _____ Tested by _____ Date _____

MOISTURE DETERMINATION			PERCENT PASSING NO. 200 SIEVE (P-200) WASH		
Moisture content	Coarse (2)	Fine (3)	P-200 content	Coarse	Fine
Weight of wet aggregate	14.18	680.7	Weight of wet aggregate		
Weight of dry aggregate	13.75	644.0	Weight of dry aggregate		
Weight of water	0.43	36.7	Weight of washed dry aggregate		
Moisture (%)	3.1	5.7	Weight of P-200		

REMARKS:	Coarse Aggregate Sieve size	(1) Retained			Total Passing (%)	Spec's
		Wt Wet	Wt Dry	%		
	inch					
	2 inch	0	0	0		
	1 1/2 inch	3.12	3.03	3.3		
	1 inch	8.88	8.61	9.3		
	1/2 inch	18.80	18.23	19.7		
	inch					
	No. 4	17.08	16.57	17.9		
	No. 4 minus	48.62	46.00	49.8		
	Total sample Wt	96.50	92.44			

Fine Aggregate Sieve size	WASHED FROM COARSE				(6) DRY NO. 4 MINUS				Total Passing (%)	Spec's
	Retained		Percent Passing	Adjusted (%) Passing	Retained		Percent Passing	Adjusted (%) Passing		
	Wt. Dry	%				Wt Dry			%	
No. 4				0	0	100			49.8	
No. 10				218.3	33.9	66.1			32.9	
No. 40				206.1	32.0	34.1			17.0	
No. 100				76.0	11.8	22.3			11.1	
No. 200				94.7	14.7	7.6			3.8	
Pan				48.9	7.6					
Wt. P-200										
Total P-200										
Orig. Dry Wt.				644.0						

SIEVE ANALYSIS OF COARSE & FINE AGGREGATE

Instructions

TOTAL SIZE OF SAMPLE TO BE TESTED:

Split or quarter out the size of sample to test using the following table.

Maximum size of Rock	Weight of sample to test
9.5 mm (3/8")	1 kg
12.5 mm (1/2")	2 kg
19.0 mm (3/4")	5 kg
25.0 mm (1")	10 kg
*37.5 mm (1 1/2")	15 kg
50 mm (2")	20 kg
63 mm (2 1/2")	35 kg
75 mm (3")	60 kg
90 mm (3 1/2")	100 kg

For this example we will use *37.5 mm (1-1/2) minus size rock. This means you will need a 15 kg (33) pound sample to test.

Step (1) Get total weight of the sample, record this on sieve form.

Step (2) Check the project specifications for the sieve sizes to use, record these on sieve form under Step (2) - NOTE see Step (26).

Sieve the total sample over a set of screens, using the ones shown in Step (2) on the form (you will be using screens and a shaker like we used in the barn).

Step (3) Weigh each of the sizes you sieved and record them on the sieve form, Step (3). This should check the total weight shown on the form under Step (1).

Next combine all of the 4.75 mm (No. 4) plus material and split out two samples (approximately 5,000 grams) of this material.

Step (4) Mark one of these samples moisture content weight and record it as wt. of wet aggregate next to Step (4) on the form. Weigh this sample in grams.

Step (5) Mark the other coarse sample P-75 μ m (P-200) content. Weigh and record it as wt. of wet aggregate next to Step (5) on the form. Weigh this sample in grams.

Next take all of the 4.75 mm (No. 4) minus and split out two 500 to 600 gram samples.

Step (6) Mark one of these samples moisture content, weigh and record it as wt. of wet aggregate under Step (6), weigh this sample in grams.

Step (7) Mark the other fine sample P-75 μm (P-200) content, weigh and record it as wt. wet aggregate under Step (7) on the form. Weigh this sample in grams.

Next place the samples from Step (4) and Step (6) under the dryer. These are your moisture samples. Next wash the coarse material next to Step (5). This is done by placing a sieve in the range of 2.36 mm (No. 8) to 1.18 mm (No. 16) sieve over the 75 μm (No. 200) sieve, then pouring the coarse material over the nested sieves and wash till clean. Then remove all of the clean material from the nested sieves and put it in a pan and place it under the dryer to dry.

Next wash the fine material recorded under Step (7). This is done by pouring the sample over the 75 μm (No. 200) sieve and washing till clean. Then remove all clean material from the 75 μm (No. 200) sieve and put it in a pan and place it under the dryer to dry.

When samples recorded next to Step (4) and Step (5) and under Step (6) and Step (7) are dry, do the following.

Step (8) Weigh up the sample of coarse material recorded next to Step (4) and record this weight under Step (8).

Step (9) Subtract Step (8) from Step (4) and record the results under Step (9).

Step (10) Divide Step (8) into Step (9) and record results under Step (10).

$$\frac{70.1 \times 100}{3649.3} = 1.92$$

Step (11) Weigh up the sample of fine material recorded under Step (6) and record this weight under Step (11).

Step (12) Subtract Step (11) from Step (6) and record results under Step (12).

Step (13) Divide Step (11) into Step (12) and record results under Step (13).

$$\frac{15.0}{510.0} \times 100 = 2.94$$

Step (14) Add moisture content under Step (10) plus 100.0 (1.92 + 100.0 = 101.92) then divide the results by 100.

$$\frac{101.92}{100} = 1.0192$$

Next divide the results into the value next to Step (5).

$$\frac{3764.8}{1.0192} = 3693.9$$

Record this result next to Step (14).

Step (15) Weigh up the material recorded next to Step (5) and record this weight next to Step (15).

Step (16) Subtract Step (15) from Step (14) and record results next to Step (16).

$$\begin{array}{r} 3693.9 \\ -3662.0 \\ \hline 31.9 \end{array}$$

Step (17) Add moisture content under Step (13) plus 100.0 (2.94 + 100 = 102.94) then divide the result by 100.

$$\frac{102.94}{100} = 1.0294$$

Next divide the result into the value next to Step (7).

$$\frac{530.5}{1.0294} = 515.3$$

Record this result under Step (17).

Step (18) Weigh up the material recorded under Step (17) and record this weight under Step (18).

Step (19) Subtract Step (18) from Step (17) and record results under Step (19).

$$\begin{array}{r} 515.3 \\ -489.1 \\ \hline 26.2 \end{array}$$

Step (20) Add moisture content under Step (10) plus 100.0 (1.92 + 100.0 = 101.92). Then divide the result by 100.

$$\frac{101.92}{100} = 1.0192$$

Next divide this result into each of the weights under Step (3) down through the 4.75 mm (No. 4) size. Example:

$$\frac{2.55}{1.0192} = 2.50 \quad \frac{3.45}{1.0192} = 3.39 \quad \frac{2.00}{1.0192} = 1.96 \quad \frac{4.00}{1.0192} = 3.92$$

$$\frac{4.50}{1.0192} = 4.42$$

Step (21) Add moisture content under Step (13) plus 100.0 (2.94 + 100.0 = 102.94). Then divide the result by 100.

$$\frac{102.94}{100} = 1.0294$$

Next divide this result into the wet wt. next to the 4.75 mm (No. 4) minus size.

$$\frac{16.50}{1.0294} = 16.03$$

Record this under Step (21).

Step (22) Add all weights under Step (20) plus Step (21) and record total under Step (22).

Step (23) Take result under Step (22) and Divide this by 100

$$\frac{32.22}{100} = .3222$$

Example

$$\frac{2.50}{.3222} = 7.8, \quad \frac{3.39}{.3222} = 10.5, \quad \frac{1.96}{.3222} = 6.1$$

$$\frac{3.92}{.3222} = 12.2, \quad \frac{4.42}{.3222} = 13.7, \quad \frac{16.03}{.3222} = 49.8$$

Step (24) Add all results under Step (23) and record total under Step (24), Step (24) result should equal between 99.9 to 100.1.

Step (25) Subtract each of the results under Step (23) starting with 100.0 and record these results under Step (25).

Example

$$\begin{array}{r} 100.0 \\ - 7.8 \\ \hline 92.2 \end{array} \quad \begin{array}{r} 92.2 \\ - 10.5 \\ \hline 81.7 \end{array} \quad \begin{array}{r} 81.7 \\ - 6.1 \\ \hline 75.6 \end{array} \quad \begin{array}{r} 75.6 \\ - 12.2 \\ \hline 63.4 \end{array} \quad \begin{array}{r} 63.4 \\ - 13.7 \\ \hline 49.7 * \end{array}$$

* This value should check with the last result under Step (23).

Step (26) Again check the specifications for the sieve sizes to use and record them under Step (26).

Step (27) Take the sample weighed up next to Step (15) and hand sieve it over a 4.75 mm (No. 4) sieve, then record the weight of the material retained on the 4.75 mm (No. 4) sieve next to the 4.75 mm (No. 4) sieve. All of the rest of the sample that went through the 4.75 mm (No. 4) sieve shall be placed on a stack of sieves that are recorded under Step (26) starting with the 2.00 mm (No. 10) size through the pan, this stack of sieves plus the 4.75 mm (No. 4) minus material is then placed on a sieve shaker and sieve for approximately 5 minutes.

Next weigh the material retained on each sieve and the pan under Step (27).

Step (28) Bring the result next to Step (16) and record it next to Step (28).

Step (29) Add pan weight plus result next to Step (28) record next to Step (29)

$$2.0 + 31.9 = 33.9$$

Then mark out weights recorded next to pan also result next to Step (28).

Step (30) Add the following results under Step (27).

4.75 mm	(No. 4)	=	3591.0
2.00 mm	(No. 10)	=	40.0
425 μ m	(No. 40)	=	10.0
150 μ m	(No. 100)	=	10.0
75 μ m	(No. 200)	=	9.0
Total P-75 μ m (P-200)	Step (29)	=	<u>33.9</u>

$$\text{Total} = 3693.9$$

Record this weight under Step (30). NOTE: The total of Step (30) should check Step (14).

Step (31) Take result under Step (30) and divide this by 100.

$$\frac{3693.9}{100} = 36.939$$

Then use this result and divide it into each of the results under Step (26) down through the 75 μ m (No. 200), also divide into result next to Step (29).

Record all results opposite their sieve sizes under Step (31).

Example:

$$4.75 \text{ mm (No. 4): } \frac{3591.0}{36.939} = 97.2 \quad 2.00 \text{ mm (No. 10): } \frac{40.0}{36.939} = 1.1$$

$$425 \mu\text{m (No. 40): } \frac{10.0}{36.939} = 0.3 \quad 150 \mu\text{m (No. 100): } \frac{10.0}{36.939} = 0.3$$

$$75 \mu\text{m (No. 200): } \frac{9.0}{36.939} = 0.2 \quad (\text{Total } 75 \mu\text{m (P-200) Step(29)}):$$

$$\frac{33.9}{36.939} = 0.9$$

Step (32) Add all results under Step (31), they should equal between 99.9 to 100.1.

Step (33) Subtract each of the results under Step (31) starting with 100.0 and record these results under Step (33).

Example:

$$\begin{array}{r}
 100.0 \\
 - \underline{97.2} \\
 2.8
 \end{array}
 \quad
 \begin{array}{r}
 2.8 \\
 - \underline{1.1} \\
 1.7
 \end{array}
 \quad
 \begin{array}{r}
 1.7 \\
 - \underline{0.3} \\
 1.4
 \end{array}
 \quad
 \begin{array}{r}
 1.4 \\
 - \underline{0.3} \\
 1.1
 \end{array}
 \quad
 \begin{array}{r}
 1.1 \\
 - \underline{0.2} \\
 0.9
 \end{array}$$

Step (34) Take the last value under Step (25) and subtract it from 100.0.

$$\begin{array}{r}
 100.0 \\
 - \underline{49.7} \\
 50.3
 \end{array}$$

Then divide 100 into this result divide $\frac{50.3}{100.0} = .503$

Take this result times each of the results under Step (33).

Example:

$$\begin{array}{l}
 2.8 \times .503 = 1.4 \\
 1.7 \times .503 = 0.9 \\
 1.4 \times .503 = 0.7 \\
 1.1 \times .503 = 0.6 \\
 0.9 \times .503 = 0.5
 \end{array}$$

Step (35) Take the sample weighed up under Step (18) and place it on a stack of sieves recorded under Step (26), starting with the 2.00 mm (No. 10) size through the pan. Sieve these for approximately 5 minutes.

Next weigh the material retained on each sieve and the pan and record these weights under Step (35) opposite the size they represent.

Step (36) Bring the result under Step (19) and record it under Step (36).

Step (37) Add pan weight plus result under Step (36) record this under Step (37).

$$4.1 + 26.2 = 30.3$$

Then mark out weights recorded next to pan also result under Step (36).

Step (38) Add the following results under Step (35).

2.00 mm	(No. 10)	= 150.0
425 μ m	(No. 40)	= 200.0
150 μ m	(No. 100)	= 100.0
75 μ m	(No. 200)	= 35.0
Total P- 75 μ m (P-200) Step (37)		= <u>30.3</u>
		Total = 525.3

Step (39) Take result under Step (38) and divide this by 100, $515.3 = \frac{5.153}{100}$

Then use this result and divide it into each of the results under Step (35) down through the 75 μm (No. 200) also divide into result under Step (38).

Record all results opposite their sieve sizes under Step (39).

Example: 2.00 mm (No. 10): $\frac{150.0}{5.153} = 29.1$ 4.25 mm (No.40): $\frac{200.0}{5.153} = 38.8$
150 μm (No. 100): $\frac{100.0}{5.153} = 19.4$ 75 μm (No. 200): $\frac{35.0}{5.153} = 6.8$
Total 75 μm (P-200) Step (37): $\frac{30.3}{5.153} = 5.9$

Step (40) Add all results under Step (39) they should equal between 99.0 to 100.1.

Step (41) Subtract each of the results under Step (39). Starting with 100.0 and record these results under Step (41).

Example: $100.0 - 70.9 = 29.1$ $70.9 - 32.1 = 38.8$ $32.1 - 12.7 = 19.4$ $12.7 - 5.9 = 7.8$
 $70.9 - 32.1 = 38.8$ $32.1 - 12.7 = 19.4$ $12.7 - 5.9 = 7.8$ $5.9 - 0 = 5.9$

Step (42) Take the last value under Step (25) and divide 100 into this result

$\frac{49.7}{100.0} = .497$

Take this result times each of the results under Step (41).

Example: $100.0 \times .497 = 49.7$
 $70.9 \times .497 = 35.2$
 $32.1 \times .497 = 16.0$
 $12.7 \times .497 = 6.3$
 $5.9 \times .497 = 2.9$

Step (43) Add the results under Step (34) and Step (42), record results under Step (43).

Example: Sieve Size

4.75 mm (No. 4)	$1.4 + 49.7 = 51.1$
2.00 mm (No. 10)	$0.9 + 35.2 = 36.1$
425 μm (No. 40)	$0.7 + 16.0 = 16.7$
150 μm (No. 100)	$0.6 + 6.3 = 6.9$
75 μm (No. 200)	$0.5 + 2.9 = 3.4$

Step (44) Cross out last result under Step (25) this result is changed as shown in the first value under Step (43).

Note: The last result under Step (25) is not crossed out on this example, but it should be when running the gradation test for control results.

Table 2
MAXIMUM LOADING FOR TYPICAL SIEVES

Sieve Size (mm)	Sieve Size	Maximum Wt. in (kg/m ²)	Maximum Wt. in (g/in ²)	Round Sieve 203 mm (8 in) Max wt. (g)	Round Sieve 305 mm (12 in) Max wt. (g)	Square Sieve 356 mm (14 in) Max wt. (g)
75.0	3"	188	121	6,079	13,678	23,704
63.0	2 1/2 "	158	102	5,106	11,489	19,911
50.0	2"	125	81	4,053	9,119	15,803
37.5	1 1/2"	94	60	3,040	6,839	11,852
31.5	1 1/4"	79	51	2,553	5,745	9,956
25.0	1"	63	40	2,026	4,559	7,901
19.0	3/4"	48	31	1,540	3,465	6,005
12.5	1/2"	31	20	1,013	2,280	3,951
9.5	3/8"	24	15	770	1,733	3,002
6.3	1/4"	16	10	511	1,149	1,991
4.75	#4	12	8	385	866	1,501
2.36	#8	6	4	195	438	759
2.00	#10	6	4	195	438	759
1.70	#12	6	4	195	438	759
1.18	#16	6	4	195	438	759
0.600	#30	6	4	195	438	759
0.425	#40	6	4	195	438	759
0.300	#50	6	4	195	438	759
0.180	#80	6	4	195	438	759
0.150	#100	6	4	195	438	759
0.075	#200	6	4	195	438	759

Note: The above data is based on the 1993 AASHTO Methods of Sampling and Testing, T-27 and T-30 requirements for sieve loading. This requirement states that the maximum load for sieves with openings of 4.75 mm (#4) and larger shall not exceed the product of 2.5 x (the sieve opening in millimeters), and 6kg/square meter for sieves with openings smaller than the 4.75 mm (#4).



**WORKSHEET FOR SIEVE ANALYSIS OF FINE AND COARSE AGGREGATE
AASHTO T 11 AND AASHTO T 27**

Project EXAMPLE Source _____ Sample No. _____

Sample of 1 1/2" MINUS Quantity represented _____ Lot No. _____

Sampled by _____ Date _____ Tested by _____ Date _____

MOISTURE DETERMINATION			PERCENT PASSING NO. 200 SIEVE (P-200) WASH		
Moisture content	Coarse	Fine	P-200 content	Coarse	Fine
Weight of wet aggregate	3719.4 (4)	525.0 (6)	Weight of wet aggregate	3764.8 (5)	530.5 (7)
Weight of dry aggregate	3649.3 (8)	510.0 (11)	Weight of dry aggregate	3693.9 (14)	515.3 (17)
Weight of water	70.1 (9)	15.0 (12)	Weight of washed dry aggregate	3662.0 (15)	489.1 (18)
Moisture (%)	1.92 (10)	2.94 (13)	Weight of P-200	31.9 (16)	26.2 (19)

REMARKS:
○ = STEP NO.

INITIAL SAMPLE
WT. = 33 LBS. (1)

SHOULD CHECK

Coarse Aggregate Sieve size	Retained			Total Passing (%)	Spec's
	Wt Wet	Wt Dry	%		
(2) inch	(5)	(20)	(23)	(25)	
1 1/2 inch	0	0	0	100.0	
1 inch	2.55	2.50	7.0	92.2	
3/4 inch	3.45	3.39	10.5	81.7	
1/2 inch	2.00	1.96	6.1	75.6	
3/8 inch	4.00	3.92	12.2	63.4	
No. 4	4.50	4.42	13.7	49.7	
No. 4 minus	16.50	16.03	49.7	CHECK	
Total sample Wt	33.00	32.22	100.0		

Fine Aggregate Sieve size	WASHED FROM COARSE				DRY NO. 4 MINUS				Total Passing (%)	Spec's
	Retained		Percent Passing (33)	Adjusted (%) Passing (34)	Retained		Percent Passing (41)	Adjusted (%) Passing (42)		
	Wt. Dry (27)	% (31)			Wt Dry (35)	% (39)				
(26) No. 4	3591.0	97.2	2.8	1.4	0	0	100.0	49.7	51.1 (49)	
No.	40.0	1.1	1.7	0.9	150.0	29.1	70.9	35.2	36.1	
No.	10.0	0.3	1.4	0.7	200.0	38.8	32.1	16.0	16.7	
No.	10.0	0.3	1.1	0.6	100.0	19.4	12.7	6.3	6.9	
No.	9.0	0.2	0.9	0.5	35.0	6.8	5.9	2.9	3.4	
Pan	2.0				4.1					
Wt. P-200 (28)	31.9				26.2 (36)					
Total P-200 (29)	33.9	0.9			30.3 (37)	5.9				
Orig. Dry Wt (30)	3693.9	100.0			515.3 (38)	100.0 (40)				

(INTENTIONALLY LEFT BLANK)

Standard Method of Test for

Mechanical Analysis of Extracted Aggregate WFLHD Designation: T 30-94 (Modified AASHTO T 30)

1. SCOPE

1.1 This method of test covers a procedure for the determination of the particle size distribution of fine and coarse aggregates extracted from asphaltic mixtures using sieves with square openings.

2. APPARATUS

2.1 The apparatus shall consist of the following:

2.1.1 Balance - A balance shall conform to AASHTO M 231, Class D for samples less than 5000 g, Class E for samples of 5000 g or more.

2.1.2 Sieves - The sieves with square openings shall be mounted on substantial frames constructed in a manner that will prevent loss of material during sieving. Suitable sieve sizes shall be selected to furnish the information required by the specifications covering the material to be tested. The woven wire cloth sieves shall conform to the requirements of AASHTO M 92 for Sieves for Testing Purposes.

3. SAMPLE

3.1 The sample shall consist of the entire lot or sample of aggregate determined according to Section 8 of AASHTO T 164, Test for Quantitative Extraction of Bitumen from Bituminous Paving Mixtures, from which the bituminous material has been extracted.

4. PROCEDURE

4.1 The sample shall be dried until further drying at 110 ± 5 C (230 ± 9 F) does not alter the weight 0.1 percent, the precision of weighing. AASHTO T 255 provides a method to determine if elevated drying temperatures may be used. The total weight of aggregate in the asphaltic mixture being tested is the sum of the weights of the dried aggregates and the minus 75 μ m (No. 200) material contained on the filter blanket assembly.

Note 1 - When using nested sieves in AASHTO T 164, Method E and washing the mixture with solvent as part of the extraction procedure, then Section 4.2 through Section 4.4 may be omitted and the dried filter blanket assembly shall be treated in accordance with Section 4.5.

4.2 The test sample after being dried and weighed shall be placed in a container and covered with water. Add a sufficient amount of wetting agent to assure a thorough separation of the material finer than the 75 μ m (No. 200) sieve from the coarser particles. The contents of the container shall be agitated vigorously and the wash water immediately poured over a nest of two sieves consisting of a 2.36 mm (No. 8) or 1.18 mm (No. 16) sieve superimposed on a 75 μ m (No. 200) sieve. The use of a large spoon to stir and agitate the aggregate in the wash water has been found satisfactory.

Note 2 - Wetting agents may include any dispersing agent such as Calgon, Joy, or other detergent, or a soap, which will promote the separation of fine material.

4.3 The agitation shall be sufficiently vigorous to result in the complete separation from the coarse particles of all particles finer than the 75 μm (No. 200) sieve and bring them into suspension in order that they may be removed by decantation of the wash water. Care shall be taken to avoid, as much as possible, the decantation of the coarse particles of the sample. The operation shall be repeated until the wash water is clear.

4.4 All material retained on the nested sieves shall be returned to the container. The washed aggregate in the container shall be dried to constant weight at a temperature of 110 ± 5 C (230 ± 9 F) and weighed to the nearest 0.1 percent.

4.5 The aggregate shall then be sieved over sieves of the various sizes required by the specification covering the mixture, including the 75 μm (No. 200) sieve. For sieves with openings smaller than 4.75 mm (No. 4), the weight retained on any sieve at the completion of the sieving operation shall not exceed 6 kg/m² of sieving surface. For sieves with openings 4.75 mm (No. 4) and larger, the weight in kg shall not exceed the product of 2.5 X (sieve opening in mm) X (the sieving surface area in m²). See Table 2. The weight of material passing each sieve and retained on the next and the amount passing the 75 μm (No. 200) sieve shall be recorded. The summation of these various weights must check the dried weight after washing within 0.2 percent of the total weight. The weight of dry material passing the 75 μm (No. 200) sieve by dry sieving (see Note 1) shall be added to the weight of minus 75 μm (No. 200) material on the filter blanket or the weight removed by washing in Section 4.4 as applicable, in order to obtain the total passing the 75 μm (No. 200) sieve. The weights of fractions retained on the various sieves and the total passing the 75 μm (No. 200) sieve shall be converted to percentages by dividing each by the total weight of aggregate in the bituminous mixture from 4.1.

5. REPORT

5.1 The results of the sieve analysis shall be reported as follows: (a) Total percentages passing each sieve, or (b) total percentages retained on each sieve, or (c) percentages retained between consecutive sieves, depending upon the form of the specifications for the use of the material under test. Percentages shall be reported to the nearest 0.1 percent.

6. PRECISION

6.1 For a well graded aggregate with a nominal maximum size of 19.0 mm (3/4 in.), the precision indexes are given in Table 1; the values are given for each of the commonly used sieves.

Table 1
Precision

Sieve	Maximum Difference Expected for One Sample Run by Two Laboratories
19.0 mm (3/4 in.)	2.0
9.5 mm - 12.5 mm (3/8 - 1/2 in.)	5.0
4.75 mm (No. 4)	6.0
2.00 mm - 2.36 mm (No. 10 - No. 8)	5.0
180 μ m - 425 μ m (No. 80 - No. 40)	2.5
75 μ m (No. 200)	1.5

Table 2
MAXIMUM LOADING FOR TYPICAL SIEVES

Sieve Size (mm)	Sieve Size	Maximum Wt. in (kg/m ²)	Maximum Wt. in (g/in ²)	Round Sieve 203 mm (8 in) Max wt. (g)	Round Sieve 305 mm (12 in) Max wt. (g)	Square Sieve 356 mm (14 in) Max wt. (g)
75.0	3"	188	121	6,079	13,678	23,704
63.0	2 1/2 "	158	102	5,106	11,489	19,911
50.0	2"	125	81	4,053	9,119	15,803
37.5	1 1/2"	94	60	3,040	6,839	11,852
31.5	1 1/4"	79	51	2,553	5,745	9,956
25.0	1"	63	40	2,026	4,559	7,901
19.0	3/4"	48	31	1,540	3,465	6,005
12.5	1/2"	31	20	1,013	2,280	3,951
9.5	3/8"	24	15	770	1,733	3,002
6.3	1/4"	16	10	511	1,149	1,991
4.75	#4	12	8	385	866	1,501
2.36	#8	6	4	195	438	759
2.00	#10	6	4	195	438	759
1.70	#12	6	4	195	438	759
1.18	#16	6	4	195	438	759
0.600	#30	6	4	195	438	759
0.425	#40	6	4	195	438	759
0.300	#50	6	4	195	438	759
0.180	#80	6	4	195	438	759
0.150	#100	6	4	195	438	759
0.075	#200	6	4	195	438	759

Note: The above data is based on the 1993 AASHTO Methods of Sampling and Testing, T-27 and T-30 requirements for sieve loading. This requirement states that the maximum load for sieves with openings of 4.75 mm (#4) and larger shall not exceed the product of 2.5 x (the sieve opening in millimeters), and 6kg/square meter for sieves with openings smaller than the 4.75 mm (#4).

(INTENTIONALLY LEFT BLANK)

Standard Method of
Sampling Asphalt Materials
WFLHD Designation: T 40-94 (Modified AASHTO T 40)

1. SCOPE

1.1 This method applies to the sampling of liquid, semi-solid, or solid asphaltic materials at the point of manufacture, supply terminal, or at the point of shipment delivery.

1.2 Samples may be taken from tanks, stockpiles, vehicles, or containers used for the storage or shipping of asphalt materials.

2. PURPOSE

2.1 Sampling is as important as testing, and every precaution shall be taken to obtain samples that will show the true nature and condition of the materials.

2.2 Samples may be taken by methods to be described hereinafter for either of the following three purposes:

2.2.1 To represent as nearly as possible an average of the bulk of the material sampled or

2.2.2 To ascertain the maximum variation in characteristics which the material possesses or

2.2.3 To determine compliance with the specifications.

3. SIZE OF SAMPLES

3.1 The sample size of liquid materials shall be as follows:

3.1.1 For routine laboratory examination not less than 1 liter (1 qt.) (emulsions, 4 liters, 1 gal. or).

3.1.2 From bulk storage, 1 liter (1 qt.) for each sampling valve,

3.1.3 From barrels or drums, 1 liter (1 qt.).

3.2 The sample size of semi-solid or solid materials shall be as follows:

3.2.1 From barrels, drums, or cakes, 1 kg (2 to 3 lbs.),

3.2.2 From crushed or powdered material in bulk or bags, 1 kg (2 to 3 lbs.).

4. CONTAINERS

4.1 Types of Containers.

4.1.1 Containers for liquid asphaltic material samples, except emulsions, shall be double friction-top cans, square cans with screw tops, or small-mouth cans with screw caps.

4.1.2 Containers for anionic emulsified asphalt samples shall be widemouth jars or bottles made of glass or plastic.

4.1.3 Containers for cationic emulsified asphalt samples shall be widemouth jars or bottles made of plastic.

Note 1 - Widemouth jars or bottles made of glass may be permitted if previous experience has shown them to be satisfactory.

4.2 Size of Containers.

4.2.1 The size of the container shall correspond to the required amount of sample.

5. PROTECTION AND PRESERVATION OF SAMPLES

5.1 Sample containers shall be new. They shall not be washed or rinsed, or wiped with oily cloth. If they contain evidence of solder flux, or if they are not clean and dry, they shall not be used. Top and container shall fit together tightly.

5.2 Care shall be taken to prevent the sample from becoming contaminated. Immediately after filling, the containers shall be tightly and positively sealed.

5.3 The filled sample container shall not be submerged in solvent, nor shall it be wiped with a solvent saturated cloth. If cleaning is necessary use a clean dry cloth.

5.4 Samples of emulsion shall be protected from freezing by correct packaging.

5.5 Transferring samples from one container to another shall be avoided if possible, as characteristics of materials could be altered during transfer, and there is a possibility of contamination.

5.6 Immediately after filling, sealing, and cleaning (paragraph 5.3), the sampling containers shall be properly marked for identification with a suitable marking pencil on the container itself or on self-adhering labels, not on the lid. Linen tags also may be used for identification if they can be securely fastened to the containers in such a manner as to insure that they will not be lost in transit. Linen tags shall not be attached to containers by using the lids to secure them.

6. SAMPLING AT PLACE OF MANUFACTURE

Section 6 is not normally applicable to FLH field testing and has been
deliberately omitted.

7. SAMPLING FROM TANK CARS, TANK TRUCKS, DISTRIBUTOR TRUCKS, OR RECIRCULATING STORAGE TANKS

7.1 Each delivery vehicle or distributor shall be equipped with a sampling valve similar in design to those shown in Fig. 1. It shall be installed at least 0.3 m (1 foot) from the shell and shall be clearly labeled as a "Sampling Valve." Before the sample is taken from the sample valve a minimum of 4 liters (1 gal.) shall be drawn from the sample valve and discarded.

8. SAMPLING FROM TANKERS AND BARGES

Section 8 is not normally applicable to FLH field testing and has been
deliberately omitted.

9. SAMPLING FROM PIPE LINES DURING LOADING OR UNLOADING

Section 9 is not normally applicable to FLH field testing and has been
deliberately omitted.

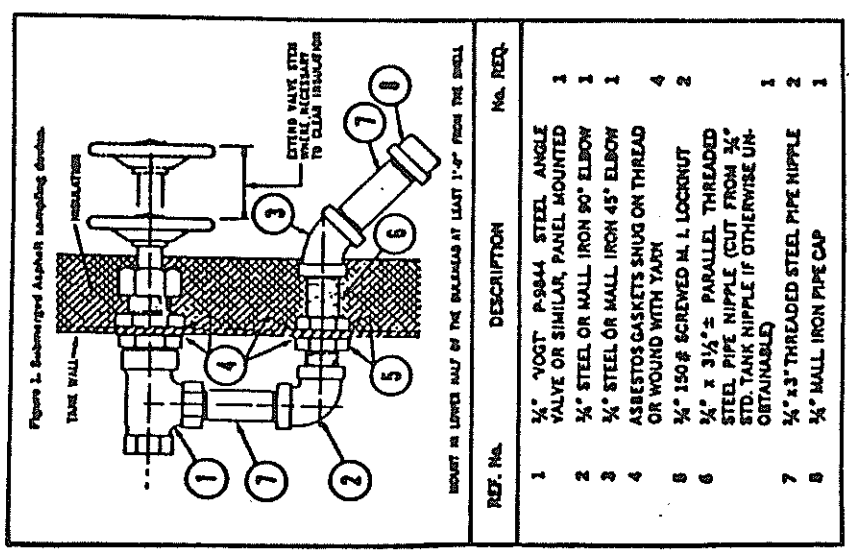
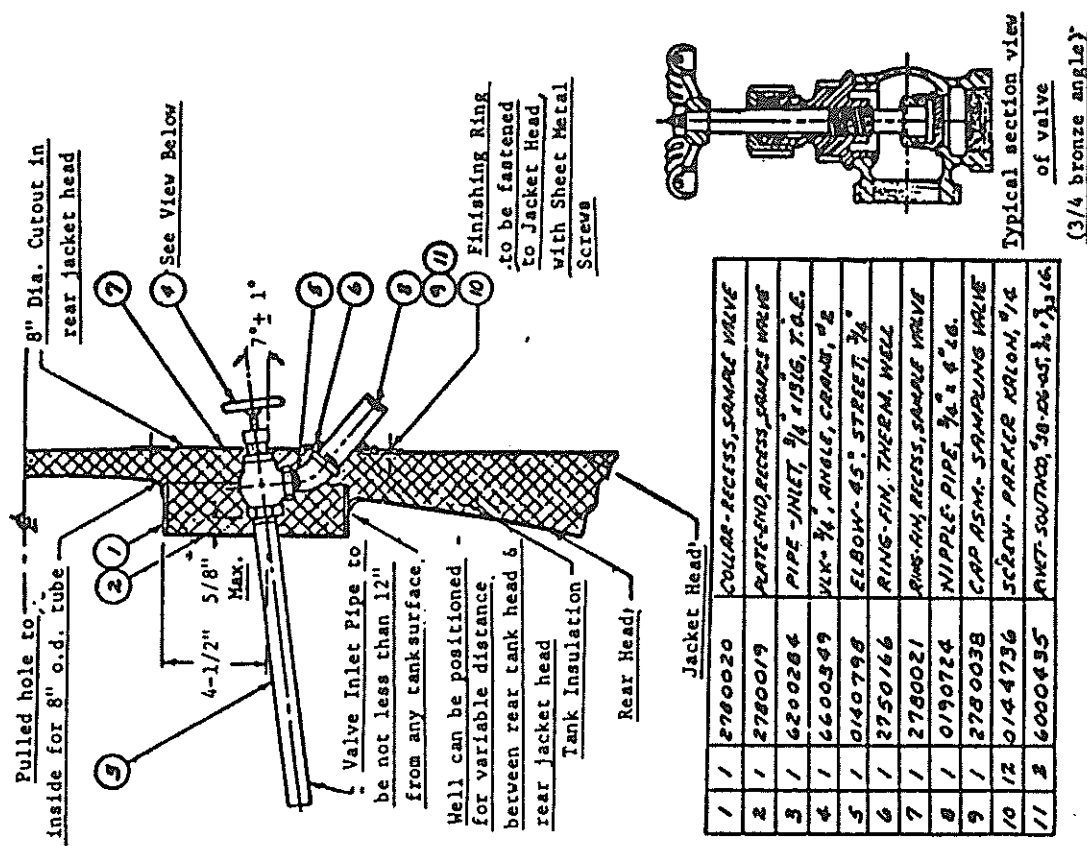

Fig. 1 - Typical Asphalt Sampling Devices

10. SAMPLING FROM DRUMS OR BARRELS

10.1 After thorough mixing, samples of liquid asphaltic material from barrels or drums shall be secured by Tube or Thief Sampling by taking 1 liter (1 qt.) of material from packages selected at random according to Section 11, Sampling Semi-solid or Uncrushed Solid Materials.

11. SAMPLING SEMI-SOLID OR UNCRUSHED SOLID MATERIALS

11.1 Drums, Barrels, Cartons, and Bags - Where the lot of material to be sampled is obviously from a single run or batch of the producer, one package shall be selected at random and sampled as described below. Where the lot of material to be sampled is not obviously from a single run or batch of the producer, or where the single sample selected as described above fails on test to conform to the requirements of the specifications, a number of packages (equivalent to the cube root of the total number of packages in the lot) shall be selected at random. The following table is given showing the number of samples to be selected for shipments of various sizes.

Packages in Shipment	Packages Selected
2 to 8	2
9 to 27	3
28 to 64	4
65 to 125	5
126 to 216	6
217 to 343	7
344 to 512	8
513 to 729	9
730 to 1000	10
1001 to 1331	11

Samples shall be taken from at least 76 mm (3 in.) below the surface and at least 76 mm (3 in.) from the side of the container. A clean hatchet may be used if the material is hard enough to shatter and a broad, stiff putty knife if the material is soft. When more than one package in a lot is sampled, each individual sample shall be not less than 115 g (1/4 lb.) in weight. When the lot of material is obviously from a single run or batch of the producer, all samples from the lot shall be melted and thoroughly mixed, and an average 4 liter (1 gal.) sample taken from the combined material for examination. In case more than a single run or batch of the producer is present and the batches can be clearly differentiated, a composite 4 liter (1 gal.) sample shall be prepared for examination from each batch. Where it is not possible to differentiate between the various batches, each sample shall be examined separately.

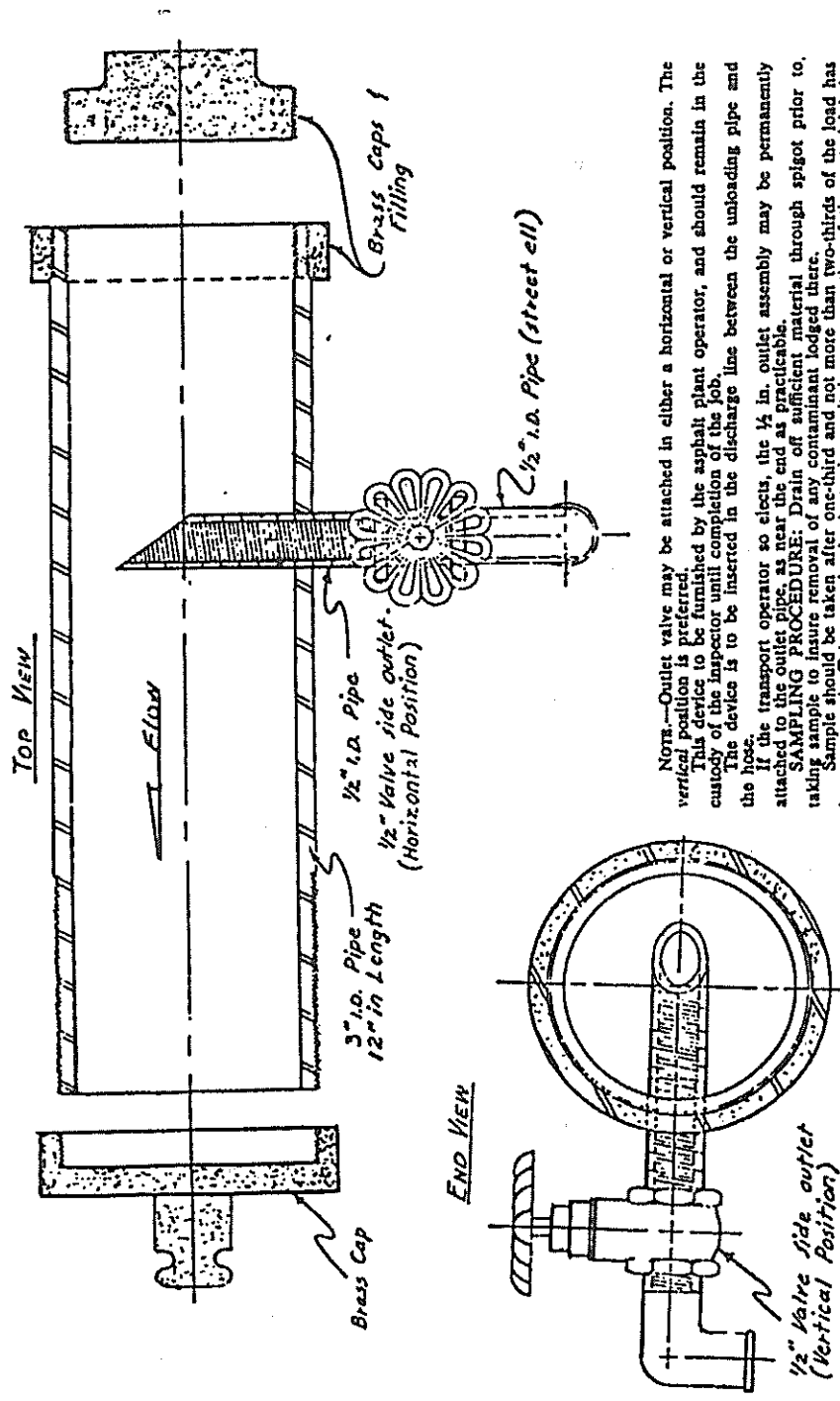

NOTE:—Outlet valve may be attached in either a horizontal or vertical position. The vertical position is preferred. This device to be furnished by the asphalt plant operator, and should remain in the custody of the inspector until completion of the job. The device is to be inserted in the discharge line between the unloading pipe and the hose. If the transport operator so elects, the 1/2 in. outlet assembly may be permanently attached to the outlet pipe, as near the end as practicable.

SAMPLING PROCEDURE: Drain off sufficient material through spigot prior to taking sample to insure removal of any contaminant lodged there. Sample should be taken after one-third and not more than two-thirds of the load has been removed. Take sample slowly to insure it is representative of the material being unloaded.

Fig. - Typical Device for Sampling of Liquid Asphalt

12. SAMPLING CRUSHED OR POWDERED MATERIALS

12.1 Bulk Storage - Solid asphaltic materials in crushed fragments or powder shall be sampled in accordance with the ASTM D 346, Sampling Coke for Analysis. The gross sample shall be not less than 25 kg (50 lbs.) from which shall be selected the 1 kg (2 to 3 lb.) sample for test.

12.2 Drums, Barrels, Bags, Cartons - Where the crushed or powdered material is in barrels, drums, or bags, a number of packages shall be selected at random as described in 11.1, Sampling Semi-solid or Uncrushed Solid Materials. A sample at least 0.7 kg (1-1/2 lbs.) in weight shall be selected from near the center of each container to yield a gross sample weighing not less than 25 kg (50 lbs.) from which the 1 kg (2 to 3 lb.) sample for test shall be selected as prescribed in the ASTM D 346.

13. SAMPLING AT POINT OF SHIPMENT DELIVERY

13.1 Sampling of asphaltic materials shall be done as soon as practicable after the asphaltic material has arrived at plant site, storage site, or job destination or at the time of unloading.

13.2 The required number of samples shall be taken from each delivery of asphaltic material. In the case of small delivery units such as distributors, the samples shall be taken to represent a maximum of 37,800 liters (10,000 gal.).

13.3 Sampling shall be done by one of the following methods:

13.3.1 By bleeding through a sample valve or tap in the storage tank. Samples taken in this manner should not be taken until sufficient mixing of the materials has occurred. Draw and discard a minimum of 4 liters (1 gal.) of the material before obtaining the sample.

13.3.2 By bleeding through a contractor provided sampling outlet in the asphaltic material feed lines connecting the plant storage tanks to the asphaltic material weighing system or spray bar. The outlet (Fig. 2) shall consist of a valve installed in such a manner that samples may be withdrawn from the line slowly at any time during plant operation. The sampling outlet shall be installed between the pump and the return line discharge in a location that is readily accessible and free from obstruction. A drainage receptacle shall be provided for flushing the outlet prior to sampling.

13.3.3 By bleeding through a sample valve between the storage tank and the mixing device. Samples should not be taken until after the new shipment is thoroughly mixed with the asphaltic material in storage.

13.4 Tests for material acceptability shall be made on the samples taken.

14. PRECAUTIONS

14.1 Because of the numerous types and grades of asphaltic materials that are alternately shipped and stored in the same or similar containers, the opportunity for contaminating these containers with residues, precipitates, or cleaning solvents, is ever present. Numerous opportunities also exist for obtaining samples which are not strictly representative of the material or are contaminated after removal. Therefore, it is incumbent upon the producer, transporter, user, and sampler to exercise continuous precaution in the sampling and handling of these materials.

Standard Method for the

Dry Preparation of Disturbed Soil
and Soil Aggregate Samples for Test
WFLHD Designation: T 87-94 (Modified AASHTO T 87)

1. SCOPE

1.1 This method describes the dry preparation of soil and soil-aggregate samples, as received from the field, for mechanical analysis, physical tests, moisture-density relations test, and other tests as may be desired.

2. APPARATUS

2.1 Balance - A balance sensitive to 0.1 g for samples weighing approximately 110 g or less; for larger samples, the balance shall be sensitive to within 0.1 percent of the sample to be weighed.

2.2 Drying Apparatus - Any suitable device capable of drying samples at a temperature not exceeding 60 C (140 F).

2.3 Sieves - A series of sieves of the following sizes: 19.0 mm, (3/4 in.) (19.0 mm), 4.75 mm (No. 4), 2.00 mm (No. 10), 425 μ m (No. 40), and others as required for preparing the sample for a specific test. The sieves shall conform to AASHTO M 92, Sieves for Testing Purposes.

Note 1 - A 50 mm (2 in.) sieve is required if the sample includes particles retained on the 19.0 mm, (3/4 in.) sieve and it is desired that the sample for moisture-density relations (AASHTO T 99 or T 180) contain material between 19.0 mm, (3/4 in.) and 4.75 mm (No. 4) sieve size to represent the fraction between 50 mm and 19.0 mm (2 in.) and (3/4 in.)

2.4 Pulverizing Apparatus - Either a mortar and rubber-covered pestle or a mechanical device consisting of a power-driven rubber-covered muller suitable for breaking up the aggregations of soil particles without reducing the size of the individual grains.

Note 2 - Other types of apparatus, such as a revolving drum into which the soil sample and rubber-covered rollers are placed and tumbled until soil aggregations are pulverized, are satisfactory if the aggregations of soil particles are broken up without reducing the size of the individual grains.

2.5 Sample Splitter - A suitable riffle sampler or sample splitter for proportional splitting of the sample and capable of obtaining representative portions of the sample without appreciable loss of fines. The width of the container used to feed the riffle sample splitter should be equal to the total combined width of the riffle chutes. Proportional splitting of the sample on a canvas cloth is also permitted.

Note 3 - The procedure for proportional splitting is described in AASHTO T 248, Reducing Field Samples of Aggregate to Testing Size.

3. SAMPLE SIZE

3.1 The amounts of soil material required to perform the individual tests are as follows:

3.1.1 Particle Size Analysis of Soils (AASHTO T 88) - For the particle size analysis material passing a 2.00 mm (No. 10) sieve is required in amounts equal to approximately 110 g for sandy soils and approximately 60 g of silty or clayey soils. A sufficient amount of material retained on either the 4.75 mm (No. 4) sieve or 2.00 mm (No. 10) sieve is required to obtain a representative gradation, and depending on the maximum particle size, shall not be less than the amount shown in the following table:

Diameter of Largest Particle, mm (in.)	Approximate Minimum Mass of Portion, g
9.5 (3/8)	500
25.0 (1)	2000
50 (2)	4000
75 (3)	5000

Note 4 - The material for coarse sieve analysis may be separated by either of two alternate methods, 4.2.1 (2.00 mm sieve) or 4.2.2 (4.75 mm sieve). When only a small percentage of the material will be retained on the 4.75 mm or 2.00 mm sieve, a considerable total weight of sample will be required to provide the minimum quantity shown in the above table; consequently, if the material represented by the sample is not to be used in a base or subbase course, select borrow, or other item having a requirement for coarse aggregate adherence to the minimum weight requirements in the above table may not be necessary.

3.1.2 Specific Gravity (AASHTO T 100) - For the specific gravity test performed in conjunction with AASHTO T 88, Particle Size Analysis of Soils, material passing the 2.00 mm (No. 10) sieve is required in the amounts (oven-dry) of at least 25 g when the volumetric flask is used and at least 10 g when the stoppered bottle is used.

3.1.3 Physical Tests - For the physical tests, material passing the No. 425 μm (40) sieve is required in the total amount of at least 300 g, allocated approximately as follows:

Test (and AASHTO Designation)	Approx. Mass, g
Liquid Limit (T 89)	100
Plastic Limit (T 90)	20
Shrinkage Factors (T 92)	30
Field Moisture Equivalent (T 93)	50
Check and Referee Tests	100

3.1.4 Other Tests - For quantity of material required for testing, refer to the specific method of test.

4. INITIAL PREPARATION OF TEST SAMPLES

4.1 The soil sample, as received from the field, shall be dried thoroughly in air or the drying apparatus at a temperature not exceeding 60 C (140 F). A representative test sample of the amount required to perform the desired tests (Section 3) shall then be obtained with the sampler, or by splitting or quartering. The aggregations of soil particles shall then be broken up in the pulverizing apparatus in such a way as to avoid reducing the natural size of individual particles.

Note 5 - Samples dried in an oven or other drying apparatus at a temperature not exceeding 60 C (140 F) are considered to be air dried.

Note 6 - Samples containing large amounts of organics may require lower drying temperatures.

4.2 The portion of the dried sample selected for particle size analysis and physical tests (including specific gravity) shall be weighed and that weight recorded as the weight of total sample uncorrected for hygroscopic moisture. This portion shall then be separated into fractions by one of the following methods:

4.2.1 **Alternate Methods Using 2.00 mm (No. 10) Sieve** - The dried sample shall be separated into two fractions using a 2.00 mm sieve. The fraction retained on the sieve shall be ground with the pulverizing apparatus until the aggregations of soil particles are broken into separate grains. The ground soil shall then be separated into two fractions using the 2.00 mm sieve.

4.2.2 **Alternate method Using 4.75 mm and 2.00 mm (No. 4 and No. 10) Sieves** - The dried sample shall first be separated into two fractions using a 4.75 mm sieve. The fraction retained on this sieve shall be ground with the pulverizing apparatus until the aggregations of soil particles are broken into separate grains, and again separated on the 4.75 mm sieve. The fraction passing the 4.75 mm sieve shall be mixed thoroughly and, by the use of the sampler or by splitting and quartering, a representative portion adequate for the desired tests shall be obtained and weighed. This split-off portion shall then be separated on the 2.00 mm sieve, and processed as in 4.2.1. The material from the split-off fraction that is retained on the 2.00 mm sieve shall be weighed for later use in coarse sieve analysis computations.

5. TEST SAMPLE FOR PARTICLE SIZE ANALYSIS AND SPECIFIC GRAVITY

5.1 The fraction retained on the 2.00 mm (No. 10) sieve in 4.2.1 or that retained on the 4.75 mm (No. 4) sieve in 4.2.2, after the second sieving, shall be set aside for use in sieve analysis of the coarse material.

5.2 The fraction passing the 2.00 mm (No. 10) sieve in both sieving operations in 4.2.1 or 4.2.2 shall be thoroughly mixed together and, by the use of the sampler or by splitting or quartering, representative portions having approximate weights as follows shall be obtained: (1) for the hydrometer analysis and sieve analysis of the fraction passing the 2.00 mm sieve, 110 g for sandy soil and 60 g for silty or clayey soils; and (2) for specific gravity, 25 g when the volumetric flask is to be used and 10 g when the stoppered bottle is to be used.

6. TEST SAMPLE FOR PHYSICAL TESTS

6.1 The remaining portion of the material passing the 2.00 mm (No. 10) sieve shall then be separated into two parts by means of a 425 μm (No. 40) sieve. The fraction retained on the 425 μm (No. 40) sieve shall be ground with the pulverizing apparatus in such a manner as to break up the aggregations without fracturing the individual grains. If the sample contains brittle particles, such as flakes of mica, fragments of sea shells, etc., the pulverizing operation shall be done carefully and with just enough pressure to free the finer material that adheres to the coarser particles. The ground soil shall then be separated into two fractions by means of the 425 μm (No. 40) sieve and the material shall be reground as before. When repeated grinding produces only a small quantity of soil passing the 425 μm (No. 40) sieve, the material retained on the 425 μm (No. 40) sieve shall be discarded. The several fractions passing the 425 μm (No. 40) sieve obtained from the grinding and sieving operations just described shall be thoroughly mixed together and set aside for use in performing the physical tests.

7. TEST SAMPLE FOR THE MOISTURE DENSITY RELATIONS

7.1 The portion of dried soil selected for the moisture-density relations test shall be separated by means of the required sieve as specified in Section 3.1.4. If necessary, the pulverizing apparatus shall be used to break up the soil aggregations retained on this sieve into separate grains. The ground soil shall then be separated into two fractions using the required sieve.

7.2 The fraction retained on the sieve after the second sieving shall be saved, if required. The fractions passing the required sieve in both sieve operations shall be thoroughly mixed and used for the moisture-density test.

Standard Method of Test for

Determining the Liquid Limit of Soils WFLHD Designation: T 89-94 (Modified AASHTO T 89)

1. DEFINITION

1.1 The Liquid Limit of a soil is the water content, as determined in accordance with the following procedure, at which the soil passes from a plastic to a liquid state.

2. APPARATUS

2.1 Dish - A porcelain dish, preferably unglazed, or similar mixing dish, about 115 mm (4-1/2 in.) in diameter.

2.2 Spatula - A spatula or pill knife having a blade about 75mm (3in.) in length and about 20 mm (3/4 in.) in width.

2.3 Liquid Limit Device:

2.3.1 Manually Operated - A device consisting of a brass dish and carriage, constructed according to the plan and dimensions shown in Fig. 1.

2.3.2 Mechanically Operated - A motorized device equipped to produce the rise and rate of stocks to a brass cup as described in Sections 4.2 and 5.3 of this procedure, respectively. The cup and the critical dimensions of the device shall conform to those shown in Fig. 1 of this procedure. The device shall give the same liquid limit values as obtained with the manually operated device.

2.4 Grooving Tool - A grooving tool conforming to the critical dimensions shown in Fig. 1. The gage need not be part of the tool.

2.5 Gage - A gage, whether attached to the grooving tool or separate, conforming to the critical dimension "e" shown in Fig. 1 and may be, if separate, a metal bar 10.00 ± 0.02 mm (0.394 ± 0.001 in.) thick and approximately 50 mm (2 in.) long.

2.6 Containers - Suitable containers, such as metal cans with lids, which will prevent loss of moisture prior to and during weighing.

2.7 Balance - A balance sensitive to 0.01 g.

2.8 Oven - A thermostatically controlled drying oven capable of maintaining temperatures of 110 ± 5 C (230 ± 9 F) for drying moisture samples.

METHOD A

3. SAMPLE

3.1 A sample weighing about 100 g shall be taken from the thoroughly mixed portion of the material passing the 425 μm (No. 40) sieve which has been obtained in accordance with AASHTO T 87, Standard Method of Preparing Disturbed Soil Samples, or T 146, Standard Method of Wet Preparation of Disturbed Soil Samples for Test; for structural analysis use AASHTO T 146, Method B.

4. ADJUSTMENT OF LIQUID LIMIT DEVICE

4.1 The Liquid Limit Device shall be inspected to determine that the device is in good working order; that the pin connecting the cup is not worn sufficiently to permit side play; that the screws connecting the cup to the hanger arm are tight; the points of contact on the cup and base are not excessively worn; that the lip of the cup is not excessively worn; and that a groove has not been worn in the cup through long usage. The grooving tool shall be inspected to determine that the critical dimensions are as shown in Fig. 1.

Note 1 - Wear is considered excessive when the point of contact on the cup or base exceeds approximately 13 mm (0.5 in.) in diameter, or when any point on the rim of the cup is worn to approximately 1/2 the original thickness. Although a slight groove in the center of the cup is noticeable, it is not objectionable. If the groove becomes pronounced before other signs of wear appear, the cup should be considered excessively worn. Excessively worn cups shall be replaced. A base which is excessively worn may be refinished as long as the thickness does not exceed the tolerance shown in Fig. 1 by more than -2.5 mm -0.1 in. and the distance between the cup at the cam follower and the base is maintained within the tolerances specified in Fig. 1.

4.2 By means of the gage, and the adjustment plate H, Fig. 1, the height to which the cup C is lifted shall be adjusted so that the point on the cup which comes in contact with the base is 10 ± 0.2 mm (0.394 ± 0.0008 in.) above the base. The adjustment plate H shall then be secured by tightening the screws I. With the gage still in place, the adjustment shall be checked by revolving the crank rapidly several times. If the adjustment is correct a slight ringing sound will be heard when the cam strikes the cam follower. If the cup is raised off the gage or no sound is heard, further adjustment shall be made.

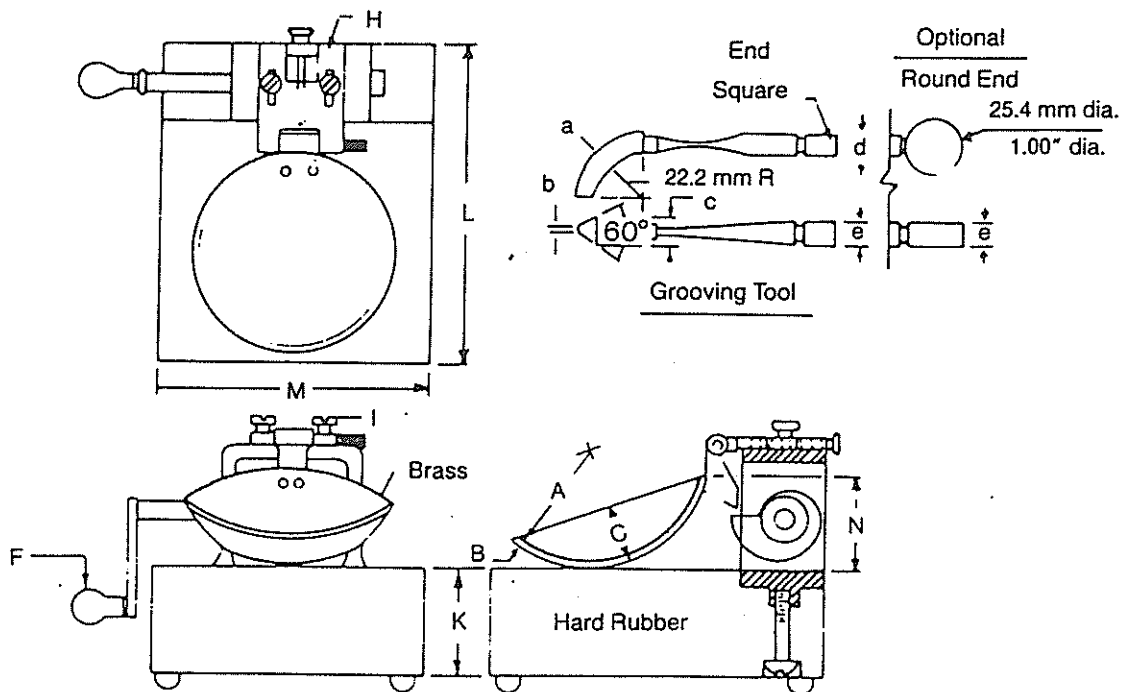

Table of Measurements

Dimension	Liquid Limit Device							Grooving Tool				
	Cup Assembly				Base			Curved End			Gage	
	A	B	C	N	K	L	M	a	b	c	d	e
Description	Radius of Cup	Thick-ness of Cup	Depth of Cup	Cup at Cam Follow-er to Base	Thick-ness	Length	Width	Thick-ness	Cutting Edge	Width	Depth	Width
Metric, mm	54	2.0	27	47	50	150	125	10.0	2.0	13.5	10.0	10.0
Tolerance, mm	2	0.1	1	1.5	5	5	5	0.1	0.1	0.1	0.2	0.02
English, in.	2.13	.079	1.063	1.850	1.97	5.90	4.92	.394	.079	.531	.3937	.3937
Tolerance, in.	.08	.004	.04	.06	.2	.2	.2	.004	.004	.004	.001	.001

NOTE Plate "H" may be designed for using 1 securing screw (I)
 An additional wear tolerance of +0.1 mm shall be allowed for dimension "b" for used grooving tools
 Feet for base shall be of resilient material.
 The metric units are the required dimension. The English Units are approximate conversions.

Fig. 1. Manual Liquid Limit Device

5. PROCEDURE

5.1 The soil sample shall be placed in the mixing dish and thoroughly mixed with 15 to 20 ml of distilled or demineralized water by alternately and repeatedly stirring, kneading, and chopping with a spatula. Further additions of water shall be made in increments of 1 to 3 ml. Each increment of water shall be thoroughly mixed with the soil as previously described before another increment of water is added. Once testing has begun, no additional dry soil should be added to the moistened soil. The cup of the Liquid Limit Device shall not be used for mixing soil and water.

Note 2 - Some soils are slow to absorb water, therefore, it is possible to add the increments of water so fast that a false liquid limit value is obtained. This can be avoided if more mixing and/or time is allowed. Tap water may be used for routine testing if comparative tests indicate no differences in results between using tap water and distilled or demineralized water. However, referee or disputed tests shall be performed using distilled or demineralized water.

5.2 When sufficient water has been thoroughly mixed with the soil to form a uniform mass of stiff consistency, a sufficient quantity of this mixture shall be placed in the cup above the spot where the cup rests on the base and shall be squeezed and spread with the spatula to level and at the same time trimmed to a depth of 10 mm at the point of maximum thickness. As few strokes of the spatula as possible shall be used, care being taken to prevent the entrapment of air bubbles within the mass. With the spatula the soil shall be leveled and at the same time trimmed to a depth of 10 mm at the point of maximum thickness. The excess soil shall be returned to the mixing dish. The soil in the cup of the device shall be divided by a firm stroke of the grooving tool along the diameter through the centerline of the cam follower so that a clean sharp groove of the proper dimensions will be formed as shown in Fig. 2. To avoid tearing of the sides of the groove or slipping of the soil cake on the cup, up to six strokes from front to back or from back to front counting as one stroke, shall be permitted. The depth of the groove should be increased with each stroke and only the last stroke should scrape the bottom of the cup.

5.3 The cup containing the sample prepared as described in 5.2 shall be lifted and dropped by turning the crank F at the rate of approximately two revolutions per second until the two sides of the sample come in contact at the bottom of the groove along a distance of about 13 mm (0.5 in.). The number of shocks required to close the groove this distance shall be recorded. The base of the machine shall not be held with the free hand while the crank F is turned.

Note 3 - Some soils tend to slide on the surface of the cup instead of flowing. If this occurs, more water should be added to the sample and remixed, then the soil-water mixture placed in the cup, a groove cut with the grooving tool and 5.2 repeated. If the soil continues to slide on the cup at a lesser number of blows than 25, the test is not applicable and a note should be made that the liquid limit could not be determined.

5.4 A slice of soil approximately the width of the spatula, extending from edge to edge of the soil cake at right angles to the groove and including that portion of the groove in which the soil flowed together, shall be removed and placed in a suitable container. The container and soil shall then be weighed promptly and the weight recorded. The soil in the container shall be oven-dried to a constant weight at 110 ± 5 C (230 ± 9 F) and weighed. This weight shall be recorded and the loss in weight due to drying shall be recorded as the weight of water.

5.5 The soil remaining in the cup shall be transferred to the mixing dish. The cup and grooving tool shall then be washed and dried in preparation for the next trial.

5.6 The foregoing operations shall be repeated for at least two additional portions of the sample to which sufficient water has been added to bring the soil to a more fluid condition. The object of this procedure is to obtain samples of such consistency that at least one determination will be made in each of the following ranges of shocks; 25-35, 20-30, 15-25, so the range in the three determinations is at least 10 shocks.

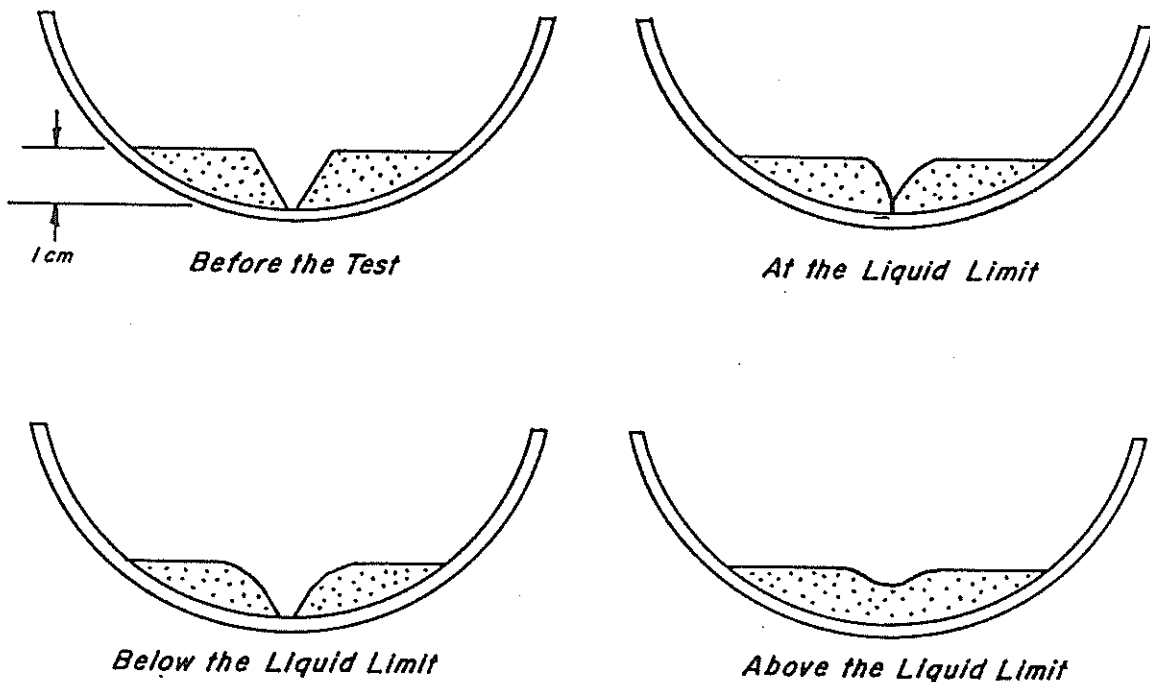

Figure 2 The Liquid Limit Test

6. CALCULATION

6.1 The water content of the soil shall be expressed as the moisture content in percentage of the weight of the oven-dried soil and shall be calculated as follows:

$$\text{Percentage moisture} = \frac{\text{mass of water}}{\text{mass of oven dried soil}} \times 100$$

7. PREPARATION OF FLOW CURVE

7.1 A "Flow Curve" representing the relation between moisture content and corresponding number of shocks shall be plotted in a semi-logarithmic graph with the moisture contents as abscissae on the arithmetical scale, and the number of shocks as ordinates on the logarithmic scale. The flow curve shall be a straight line drawn as nearly as possible through the three or more plotted points.

8. LIQUID LIMIT

8.1 The moisture content corresponding to the intersection of the flow curve with the 25 shock ordinate shall be taken as the liquid limit of the soil. Report this value to the nearest whole number.

METHOD B

9. SAMPLE

9.1 A sample weighing about 50 g shall be taken as described in 3.1.

10. PROCEDURE

10.1 The procedure shall be the same as prescribed in 5.1 through 5.5 except that the initial amount of water to be added in accordance with 5.1 shall be approximately 8 to 10 ml and the moisture sample taken in accordance with 5.4 shall be taken only for the accepted trial.

10.2 At least two groove closures shall be observed before one is accepted for the record, so as to insure the accepted number of blows is truly characteristic of the soil under test.

10.3 For accuracy equal to that obtained by the standard three-point method, the accepted number of blows for groove closure shall be restricted between 22 and 28 blows.

10.4 Groove closures between 15 and 40 blows may be accepted if variations of ± 5 percent of the true liquid limit are tolerable.

11. CALCULATION

11.1 The water content of the soil at the time of the accepted closure shall be calculated in accordance with Section 6.1.

12. LIQUID LIMIT

12.1 The liquid limit shall be determined by one of the following methods: The nomograph, Fig. 3; the straight line graph, Fig. 4; or by any other method of calculation that produces equally accurate liquid limit values. The standard three-point method shall be used as a referee test to settle all controversies.

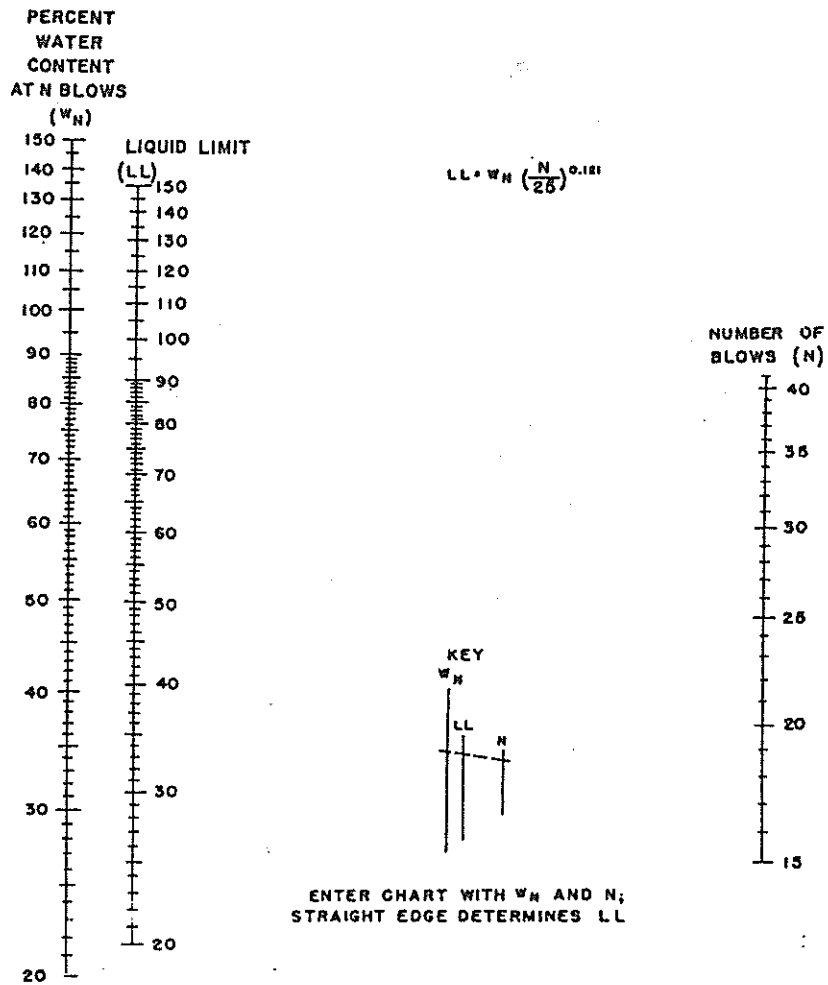

Fig. 3 Nomograph

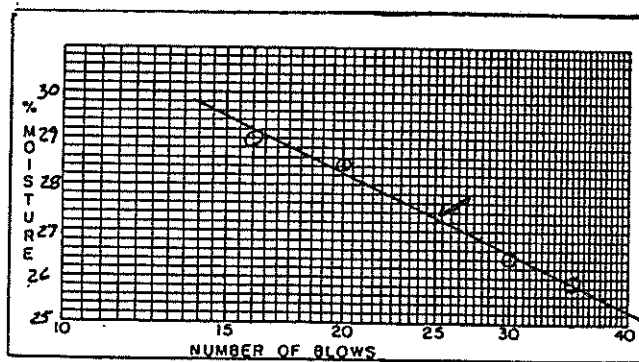

Fig. 4 Straight Line Graph

CHECK OR REFEREE TESTS

13. METHOD TO BE USED

13.1 In making check or referee tests, Method A shall be used. The results of liquid limit tests are influenced by:

- 13.1.1 The time required to make the test.
- 13.1.2 the moisture content at which the test is begun.
- 13.1.3 The addition of dry soil to the seasoned sample.

14. PROCEDURE

14.1 Therefore, in making the liquid limit test for check or referee purposes, the following time schedule shall be used:

14.1.1 Mixing of soil with water - 5 to 10 minutes, the longer period being used for the more plastic soils.

14.1.2 Seasoning in the humidifier - 30 minutes.

14.1.3 Remixing before placing in the brass cup - add 1 ml of water and mix for 1 minute.

14.1.4 Placing in the brass cup and testing - 3 minutes.

14.1.5 Adding water and remixing - 3 minutes.

14.2 No trial requiring more than 35 blows or less than 15 blows shall be recorded. In no case shall dried soil be added to the seasoned soil being tested.

15. PRECISION STATEMENT

15.1 Repeatability - (single operator) - Two results obtained by the same operator on the same sample in the same laboratory using the same apparatus, and on different days should be considered suspect if they differ by more than 7 percent of their mean.

15.2 Reproducibility - (multi-laboratory) - Two results obtained by different operators in different laboratories if they differ by more than 13 percent of their mean.

Standard Method for
Determining the Plastic Limit and
Plasticity Index of Soils
WFLHD Designation: T 90-94 (Modified AASHTO T 90)

1. DEFINITIONS

1.1 The plastic limit of a soil is the lowest water content determined in accordance with the following procedure at which the soil remains plastic. The plasticity index of a soil is the range in water content, expressed as a percentage of the mass of the oven-dried soil, within which the material is in a plastic state. It is the numerical difference between the liquid limit and plastic limit of the soil.

2. APPARATUS

2.1 The apparatus shall consist of the following:

2.1.1 Dish - A porcelain evaporating dish, or similar mixing dish about 115 mm (4-1/2 in.) in diameter.

2.1.2 Spatula - A spatula or pill knife having a blade about 76 mm (3 in.) (76 mm) in length and about 19 mm (3/4 in.) in width.

2.1.3 Surface for Rolling - A ground glass plate or piece of smooth, unglazed paper on which to roll the sample.

2.1.4 Containers - Suitable containers, such as matched watch glasses, which will prevent loss of moisture during weighing.

2.1.5 Balance - A balance sensitive to 0.01 g.

2.1.6 Oven - A thermostatically controlled drying oven capable of maintaining temperatures of 110 ± 5 C (230 ± 9 F) for drying samples.

3. SAMPLE

3.1 If the plastic limit only is required, take a quantity of soil weighing about 20 g from the thoroughly mixed portion of the material passing the 425 μ m (No. 40) sieve, obtained in accordance with the Standard Method of Dry Preparation of Disturbed Soil Samples for Test (AASHTO T 87) or the Standard Method of Wet Preparation of Disturbed Soil Samples for Test (AASHTO T 146). Place the air-dried soil in a mixing dish and thoroughly mix with distilled or demineralized water until the mass becomes plastic enough to be easily shaped into a ball. Take a portion of this ball weighing about 8 g for the test sample.

Note 1 - Tap water may be used for routine testing if comparative tests indicate no differences in results between using tap water and distilled or demineralized water. However, referee or disputed tests shall be performed using distilled or demineralized water.

3.2 If both the liquid and plastic limits are required, take a test sample weighing about 8 g from the thoroughly wet and mixed portion of the soil prepared in accordance with the Standard Method of Test for Liquid Limit for Soils (AASHTO T 89). Take the sample at any stage of the mixing process at which the mass becomes plastic enough to be easily shaped into a ball without sticking to the fingers excessively when squeezed. If the sample is taken before completion of the liquid limit test, set it aside and allow to season in air until the liquid limit test has been completed. If the sample taken during the liquid limit test is too dry to permit rolling to a 3.2 mm (1/8 in.) thread, add more water and remix.

4. PROCEDURE

4.1 Squeeze and form the 8 g test sample taken in accordance with 3.1 or 3.2 into an ellipsoidal-shape mass. Roll this mass between the fingers and the ground-glass plate or a piece of paper laying on a smooth horizontal surface with just sufficient pressure to roll the mass into a thread of uniform diameter throughout its length. The rate of rolling shall be between 80 and 90 stokes per min., counting a stroke as one complete motion of the hand forward and back to the starting position again.

4.2 When the diameter of the thread becomes 3.2 mm (1/8 in.), break the thread into six or eight pieces. Squeeze the pieces together between the thumbs and fingers of both hands into a uniform mass roughly ellipsoidal in shape and reroll. Continue this alternate rolling to a thread 3.2 mm (1/8 in.) in diameter, gathering together, kneading and rerolling, until the thread crumbles under the pressure required for rolling and the soil can no longer be rolled into a thread. The crumbling may occur when the thread has a diameter greater than 3.2 mm (1/8 in.). This shall be considered a satisfactory end point, provided the soil has been previously rolled into a thread 3.2 mm (1/8 in.) in diameter. The crumbling will manifest itself differently with the various types of soil. Some soils fall apart in numerous small aggregations of particles; others may form an outside tubular layer that starts splitting at both ends. The splitting progresses toward the middle, and finally, the thread falls apart in many small platy particles. Heavy clay soils require much pressure to deform the thread, particularly as they approach the plastic limit, and finally, the thread breaks into a series of barrel-shaped segments each about 6.4 to 9.5 mm (1/4 to 3/8 in.) in length. At no time shall the operator attempt to produce failure at exactly 3.2 mm (1/8 in.) diameter by allowing the thread to reach 3.2 mm (1/8 in.) then reducing the rate of rolling or the hand pressure, or both, and continuing the rolling without further deformation until the thread falls apart. It is permissible, however, to reduce the total amount of deformation for feebly plastic soils by making the initial diameter of the ellipsoidal-shaped mass nearer to the required 3.2 mm (1/8 in.) final diameter.

4.3 Gather the portions of the crumbled soil together and place in a suitable tared container. Weigh the container and soil to the nearest 0.01 g and record the mass. Oven-dry the soil in the container to constant mass at 110 ± 5 C (230 ± 9 F) and weigh to the nearest 0.01 g. Record the loss in mass as the mass of water.

5. CALCULATIONS

5.1 Calculate the plastic limit, expressed as the water content in percentage of the mass of the oven-dry soil, as follows:

$$\text{Plastic limit} = \frac{\text{mass of water}}{\text{mass of oven-dry soil}} \times 100$$

Report the plastic limit to the nearest whole number.

5.2 Calculate the plasticity index of a soil as the difference between its liquid limit and its plastic limit, as follows:

$$\text{Plasticity index} = \text{liquid limit} - \text{plastic limit}$$

5.3 Report the difference calculated as indicated in 5.2 as the plasticity index, except under the following conditions:

5.3.1 When the liquid limit or plastic limit cannot be determined, report the plasticity index as NP (non-plastic).

5.3.2 When the plastic limit is equal to, or greater than, the liquid limit, report the plasticity index as NP.

6. PRECISION STATEMENT

6.1 Repeatability - (single operator) - Two results obtained by the same operator on the same sample in the same laboratory using the same apparatus, and on different days should be considered suspect if they differ by more than 10 percent of their mean.

6.2 Reproducibility - (multi-laboratory) - Two results obtained by different operators in different laboratories if they differ by more than 18 percent of their mean.

(INTENTIONALLY LEFT BLANK)

Standard Method of Test for

The Moisture-Density Relations of Soils Using a 2.495 kg (5.5 lb.) Rammer and a 304.8 mm (12 in.) Drop WFLHD Designation: T 99-94 (Modified AASHTO T 99)

1. SCOPE

1.1 These methods of test are intended for determining the relation between the moisture content and density of soils compacted in a mold of a given size with a 2.495 kg (5.5 lb.) rammer dropped from a height of 305 mm (12. in.). Four alternate procedures are provided as follows:

Method A - A 101.6 mm (4 in.) mold; soil material passing a 4.75 mm (No. 4) sieve (Sections 3 and 4).

Method B - A 152.4 mm (6 in.) mold; soil material passing a 4.75 mm (No. 4) sieve (Sections 5 and 6).

Method C - A 101.6 mm (4 in.) mold; soil material passing a 19.0 mm (3/4 in.) sieve (Sections 7 and 8).

Method D - A 152.4 mm (6 in.) mold; soil material passing a 19.0 mm (3/4 in.) sieve (Sections 9 and 10).

1.2 The method to be used should be indicated in the specifications for the material being tested. If no method is specified, the provisions of Method C shall govern.

2. Apparatus

2.1 **Molds** - The molds shall be solid-wall, metal cylinders manufactured with dimensions and capacities shown in 2.1.1 and 2.1.2 below. They shall have a detachable collar assembly approximately 60 mm (2-3/8 in.) in height, to permit preparation of compacted specimens of soil-water mixtures of the desired height and volume. The mold and collar assembly shall be so constructed that it can be fastened firmly to a detachable base plate made of the same material.

Note 1 - Alternate types of molds with capacities as stipulated herein may be used, provided the test results are correlated with those of the solid-wall mold on several soil types and the same moisture-density results are obtained. Records of such correlation shall be maintained and readily available for inspection when alternate types of molds are used.

2.1.1 A 101.6 mm (4 in.) mold having a capacity of, 0.000943 ± 0.000008 m³, $1/30$ (0.0333) ± 0.0003 cu. ft. with an internal diameter of 101.6 ± 0.406 mm (4.000 ± 0.016 in.) and a height of 116.43 ± 0.1270 mm (4.584 ± 0.005 in.) Fig. 1.

2.1.2 A 152.4 mm (6 in.) mold having a capacity of 0.002124 ± 0.000021 m³ $1/13.33$ (0.07500 ± 0.00075 cu. ft.) with an internal diameter of 152.4 ± 0.6604 mm (6.000 ± 0.026 in.) and a height of (4.584 ± 0.005 in.) 116.43 ± 0.1270 mm.

2.1.3 Molds Out of Tolerance Due to Use - A mold that fails to meet manufacturing tolerances after continued service may remain in use provided those tolerances are not exceeded by more than 50 percent; and the volume of the mold, calibrated in accordance with Par. 4 (Calibration of Measure) of AASHTO T 19, for Unit Weight of Aggregate, is used in the calculations.

2.2 Rammer:

2.2.1 Manually Operated - Metal rammer having a flat circular face of 50.8 ± 0.127 mm (2.000 ± 0.005 in.) diameter, a wear tolerance of 0.13 mm (0.005 in.) and weighing 2.495 ± 0.009 kg (5.50 ± 0.02 lb.). The rammer shall be equipped with a suitable guide-sleeve to control the height of drop to a free fall of 304.8 ± 1.524 (12.00 ± 0.06 (or 1/16) in.) above the elevation of the soil. The guide-sleeve shall have at least 4 vent holes, no smaller than 9.5 mm (3/8 in.) diameter spaced approximately 90 deg. (1.57 rad) apart and approximately 19 mm (3/4 in.) from each end; and shall provide sufficient clearance so the free fall of the rammer shaft and head is unrestricted.

2.2.2 Mechanically Operated - A metal rammer which is equipped with a device to control the height of drop to a free fall of 304.8 ± 1.524 mm (12.00 ± 0.06 (or 1/16) in.) above the elevation of the soil and uniformly distributes such drops to the soil surface. The rammer shall have a flat circular face 50.8 ± 0.127 mm (2.000 ± 0.005 in.) diameter, a wear tolerance of 0.13 mm (0.005 in.) and a manufactured mass of 2.495 ± 0.009 kg (5.50 ± 0.02 lb.).

Note 2 - The mechanical rammer apparatus shall be calibrated with several soil types and the mass of the rammer adjusted, if necessary, to give the same moisture-density results as with the manually operated rammer.

It may be impractical to adjust the mechanical apparatus so the free fall is 304.8 mm (12 in.) each time the rammer is dropped, as with the manually operated rammer. To make the adjustment of free fall, the portion of loose soil to receive the initial blow should be slightly compressed with the rammer to establish the point of impact from which the 304.8 mm (12 in.) drop is determined. Subsequent blows on the layer of soil being compacted may all be applied by dropping the rammer from a height of 304.8 mm (12 in.) above the initial-setting elevation; or, when the mechanical apparatus is designed with a height adjustment for each blow, all subsequent blows should have a rammer free fall of 304.8 mm (12 in.) measured from the elevation of the soil as compacted by the previous blow.

2.2.3 Rammer Face - The circular face rammer shall be used but a sector face may be used as an alternative provided the report shall indicate type of face used other than the 50.8 mm (2 in.) circular face and it shall have an area equal to that of the circular face rammer.

2.3 Sample Extruder - A jack, lever, frame, or other device adopted for the purpose of extruding compacted specimens from the mold.

2.4 Balances and Scales - A balance or scale conforming to the requirements of AASHTO M 231, Class G 20. Also, a balance conforming to the requirements of AASHTO M 231, Class G 2.

Note 3 - The capacity of the metric balance or scale should be approximately 11.5 kg when used to weigh the 152.4 mm (6 in.) mold and compacted, moist soil; however, when the 101.6 (4 in.) mold is used, a balance or scale of lesser capacity than the 11.5 kg may be used, if the sensitivity and readability is 5 g.

2.5 Drying Oven - A thermostatically controlled drying oven capable of maintaining a temperature of 110 ± 5 C (230 ± 9 F) for drying moisture samples.

2.6 Straightedge - A hardened-steel straightedge at least 254 mm (10 in.) in length. It shall have one beveled edge, and at least one longitudinal surface (used for final trimming) shall be plane within 0.1 percent of length within the portion used for trimming the soil.

Note 4 - The beveled edge may be used for final trimming if the edge is true within a tolerance of 0.1 percent of length; however, with continued use, the cutting edge may become excessively worn and not suitable for trimming the soil to the level of the mold. The straightedge should not be so flexible that trimming the soil with the cutting edge will cause a concave soil surface.

2.7 Sieves - 50, 19.0 and 4.75 mm sieves conforming to the requirements of AASHTO M 92. Sieves for Testing Purposes.

2.8 Mixing Tools - Miscellaneous tools such as mixing pan, spoon trowel, spatula, etc., or a suitable mechanical device for thoroughly mixing the sample of soil with increments of water.

2.9 Containers - Containers for moisture content samples, made of metal or other suitable material, with close-fitting lids to prevent loss of moisture prior to or during weighing.

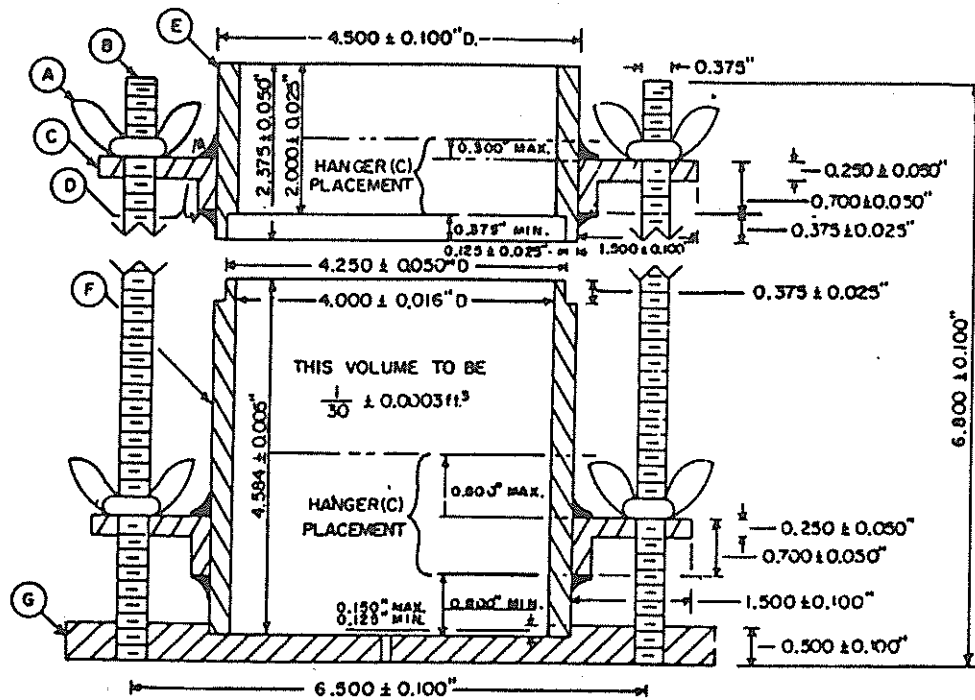

- (A) WING NUT (4)
- (B) STUD (2)
- (C) HANGER (4)
- (D) WELD (Top and bottom of each hanger)
- (E) COLLAR (1)
- (F) MOLD (1)
- (G) BASE PLATE (1)

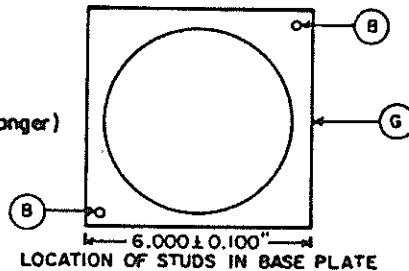

Fig. 1—Cylindrical Mold and Base Plate
(4" Mold)

 Methods A, B, and D are not normally applicable to FLH Contracts and have been deliberately omitted from this test standard.

METHOD C

7. SAMPLE

7.1 If the soil sample is damp when received from the field, dry it until it becomes friable under a trowel. Drying may be in air or by use of drying apparatus such that the temperature does not exceed 60 C (140 F). Then thoroughly break up the aggregations in such a manner as to avoid reducing the natural size of individual particles.

7.2 Sieve an adequate quantity of the representative pulverized soil over the 19.0 mm sieve, discard the coarse material, if any, retained on the 19.0 mm sieve.

Note 7 - If it is advisable to maintain the same percentage of coarse material (passing a 50 mm sieve and retained on a 4.75 mm sieve) in the moisture-density sample as in the original field sample, the material retained on the 19.0 mm sieve shall be replaced as follows: Sieve an adequate quantity of the representative pulverized soil over the 50 mm and 19.0 mm sieve. Weigh the material passing the 50 mm sieve and retained on the 19.0 mm sieve and replace it with an equal mass of material passing the 19.0 mm sieve and retained on the 4.75 mm sieve. Take the material for replacement from the remaining portion of the sample.

Note 8 - For one point proctors, the correction, if required, for different percents of plus 4.75 mm (No. 4) shall be determined in accordance with AASHTO T 224.

7.3 Select a representative sample, having a mass of approximately 5 kg (12 lb.) or more, of the soil prepared as described in 7.1 and 7.2.

8. PROCEDURE

8.1 Thoroughly mix the selected representative sample with sufficient water to dampen it to approximately 4 percentage points below optimum moisture content.

8.2 Form a specimen by compacting the prepared soil in the 101.6 mm (4 in.) mold (with collar attached) in three approximately equal layers to give a total compacted depth of about 127 mm (5 in.). Compact each layer by 25 uniformly distributed blows from the rammer dropping free from a height of 304.8mm (12 in.) above the elevation of the soil when a sleeve-type rammer is used, or from 304.8mm (12 in.) above the approximate elevation of each finally compacted layer when a stationary mounted type rammer is used. During compaction, the mold shall rest firmly on a dense, uniform, rigid and stable foundation. Each of the following has been found to be a satisfactory base on which to rest the mold during compaction of the soil: A block of concrete, weighing not less than 91 kg (200 lbs.) supported by a relatively stable foundation; a sound concrete floor; and for field application, such surfaces as found in concrete box culverts, bridges, and pavements.

8.2.1 Following compaction, remove the extension collar, carefully trim the compacted soil even with the top of the mold by means of the straightedge. Holes developed in the surface by removal of coarse material shall be patched with smaller size material. Weigh the mold and moist soil in kilograms to the nearest 5 grams or pounds to the nearest 0.01 lb. For molds conforming to tolerances given in 2.1.1 and masses recorded in kilograms, multiply the mass of the compacted specimen and mold, minus the mass of the mold, by 1059.43, and record the result as wet density, W_1 , in kg/m^3 , of compacted soil. For molds conforming to tolerances given in 2.1.1, and masses recorded in pounds, multiply the mass of the compacted specimen and the mold, minus the mass of the mold, by 30, and record the result as the wet density, W_1 , in lb/ft^3 , of compacted soil.

For used molds out of tolerance by not more than 50 percent (2.1.3), use the factor for the mold as determined in accordance with Par. 4 (Calibration of Measure), AASHTO T 19.

8.3 Remove the material from the mold and slice vertically through the center. Take a representative sample of the material from one of the cut faces, weigh immediately, and dry in an oven at 110 ± 5 C (230 ± 9 F) for at least 12 h, or to constant mass, to determine the moisture content. The moisture content sample shall weigh not less than 500 g.

8.4 Thoroughly break up the remainder of the material until it will pass a 19.0 mm sieve and 90 percent of the soil aggregations will pass a 4.75 mm sieve as judged by eye, and add to the remaining portion of the sample being tested. Add water in sufficient amount to increase the moisture content of the soil sample by one or two percentage points, and repeat the above procedure for each increment of water added. Continue this series of determinations until there is either a decrease or no change in the wet mass, W_1 , per cubic foot or cubic meter of compacted soil. This procedure has been found satisfactory in most cases. However, in instances where the soil material is fragile in character and will reduce significantly in grain size due to repeated compaction, and in cases where the soil is a heavy-textured clayey material into which it is difficult to incorporate water, a separate and new sample shall be used in each compaction test. In these cases, separate samples shall be thoroughly mixed with amounts of water sufficient to cause the moisture contents of the samples to vary by approximately two percentage points. The moisture points selected shall bracket the optimum moisture content (at least two points above and at least two points below optimum), thus providing samples which when compacted, will increase in mass to the maximum density and then decrease in mass. Oven dried samples of soil-water mixtures shall be placed in covered containers and allowed to stand for not less than 12 h before making the moisture-density test.

CALCULATIONS AND REPORT

11. CALCULATIONS

11.1 Calculate the moisture content and the dry unit mass of the soil as compacted for each trial, as follows:

$$w = \frac{A-B}{B-C} \times 100$$

and

$$W = \frac{W_1}{w+100} \times 100$$

Where:

w = percentage of moisture in the specimen, based on oven dry mass of soil,
A = mass of container and wet soil,
B = mass of container and dry soil,
C = mass of container,
W = dry mass in kg/m^3 (lbs. per cu. ft.) of compacted soil, and
 W_1 = wet mass in kg/m^3 (lbs. per cu. ft.) of compacted soil.

12. MOISTURE-DENSITY RELATIONSHIP

12.1 The calculations in 11.1 shall be made to determine the moisture content and corresponding oven-dry unit mass (density) in kilograms per cubic meter or pounds per cubic foot of the compacted samples. The oven-dry densities (unit weight) of the soil shall be plotted as ordinates and the corresponding moisture content as abscissas.

12.2 **Optimum Moisture Content** - When the densities and corresponding moisture contents for the soil have been determined and plotted as indicated in 12.1, it will be found that by connecting the plotted points with a smooth line, a curve is produced. The moisture content corresponding to the peak of the curve shall be termed the "optimum moisture-content" of the soil under the above compaction.

12.3 **Maximum Density** - The oven-dry density in kilograms per cubic meter or pounds per cubic foot of the soil at optimum moisture content shall be termed "maximum density" under the above compaction.

13. REPORT

13.1 The report shall include the following:

13.1.1 The method used (Method A, B, C, or D).

13.1.2 The optimum moisture content.

13.1.3 The maximum density in kilograms per cubic meter (lbs. per cu. ft.).

13.1.4 In Methods C and D indicate if the material retained on the 19.0 mm sieve was removed or replaced.

13.1.5 Type of face if other than 50.8 mm (2 in.) circular.

14. PRECISION STATEMENT

14.1 **Repeatability - (Single operator)** - Two results obtained by the same operation on the same sample in the same laboratory using the same apparatus, and on different days should be considered suspect if they differ by more than 10 percent of their mean for optimum moisture content and 35.24 kg per meter³ (2.2 lbs. per cu. ft.) for maximum density.

14.2 **Reproducibility - (multi-laboratory)** - Two results obtained by different operators in different laboratories if they differ by more than 15 percent of their mean for optimum moisture content and 72.08 kg per meter³ (4.5 lbs. per cu. ft.) for maximum density.

(INTENTIONALLY LEFT BLANK)

Standard Method of Test for
Moisture in Asphalt Paving Mixtures
WFLHD Designation: T 110-94 (Modified AASHTO T 110)

1. SCOPE

1.1 This method is intended for the determination, by direct measurement, of moisture in asphaltic paving mixtures.

2. APPARATUS

2.1 **Metal Still** - A vertical cylindrical still, similar to that used in AASHTO T 59, Testing Emulsified Asphalts, having a faced flange at the top to which the head is tightly attached by means of a clamp. The head shall be of metal, preferably of copper or brass, and shall be provided with a tubulation 25.4 mm (1 in.) in inside diameter.

2.2 **Condenser**, of the water-cooled reflux glass tube type, having a condenser jacket not less than 15-3/4 in. (400 mm) long with an inner tube 9.5 to 12.7 mm (3/8 to 1/2 in.) in outside diameter. The end of the condenser inserted in the trap shall be ground off at an angle of 30 deg. from the vertical axis of the condenser. For mixtures with very volatile solvents, it may be necessary to supplement this water-cooled condenser with a second water-cooled condenser of approximately the same dimensions.

2.3 Trap of well annealed glass:

2.3.1 For determination of water in asphaltic paving mixtures, a glass trap of 10 or 25 ml capacity as shown in Fig. 1 shall be used. The trap shall be graduated in 0.1 ml divisions with a ± 0.05 ml maximum error below 1 ml, and in 0.2 ml divisions with a ± 0.1 ml maximum error above 1 ml.

2.4 **Solvent** - For general use, an aromatic solvent is preferred, since it has high solvency and dispersing power for most asphaltic materials. Xylene, or a blend of 20 percent benzol and 80 percent xylene, is recommended.

2.5 **Heating Device** - Any satisfactory source of heat that will be capable of maintaining a rate of distillation of 85 to 95 drops per min.

2.6 **Microwave Oven** - A microwave oven having a defrost mode.

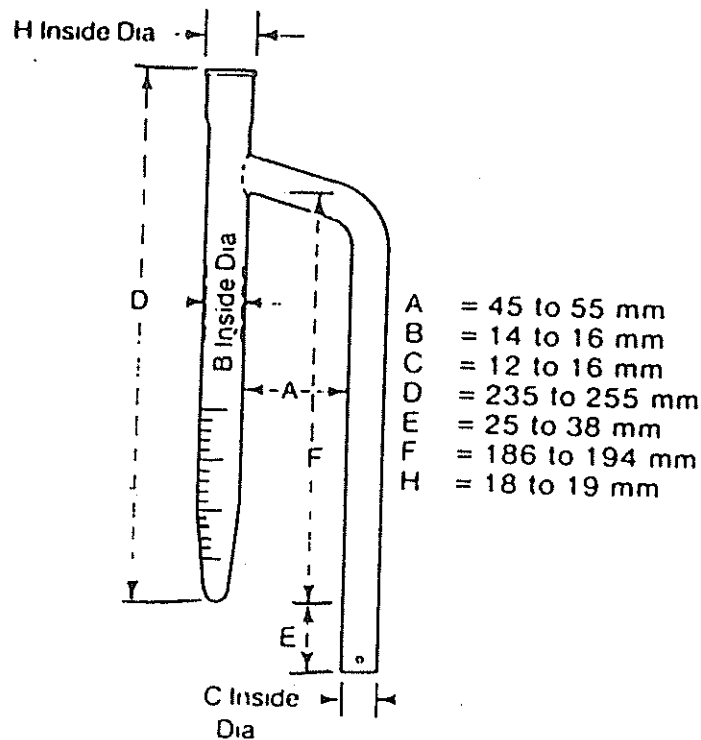

Figure 1 Typical Trap for Moisture Determination

3. SAMPLE

3.1 Sampling shall be carried out in accordance with the procedures set forth in Method T 168.

3.2 The sample shall be representative of the material and shall be of such size as to practically fill the container in which it is transported to the laboratory. For duplicate tests a 2 liter (1/2 gal.) friction-top tin pail full of the material, would be satisfactory.

4. PREPARATION OF SAMPLE

4.1 Thoroughly mix the sample and weigh out an amount estimated to show a percentage of moisture or diluent within the capacity of the trap calibration. Keep the remainder of the sample in its tightly covered container. The weighed sample should be, preferably, not less than 500 g for normal mixtures. Thoroughly break up this sample to avoid large lumps, and place it in the still.

5. PROCEDURE FOR DETERMINATION OF MOISTURE

5.1 After the sample has been placed in the still, add 200 ml of the solvent and quickly stir it into the sample. Firmly attach the still cover and assemble the trap and condenser as shown in Fig. 2. Choose a trap having a capacity adequate for the expected water content of the sample. Make all connections vapor and liquid tight. The condenser tube and trap must be chemically clean to assure free drainage of water into the bottom of the trap. Circulate cold water through the jacket of the condenser. Apply heat at such a rate that refluxing will start within 5 to 10 min. after the heat has been applied and the condensed solvent will drip into the trap at a rate of 85 to 90 drops per min. Continue the distillation until three successive readings of the trap at 15 min. intervals show no increase in the amount of water being condensed, except that in no case shall distillation continue for more than 1-1/2 h.

Note 1 - Moisture which condenses and adheres to the inside of the condenser can be removed by inserting a fine wire into the top of the condenser and running it up and down the side of the condenser tube.

5.2 Record the volume of water in the trap, and calculate and report in percentage by mass of sample taken as described in Section 7.1.

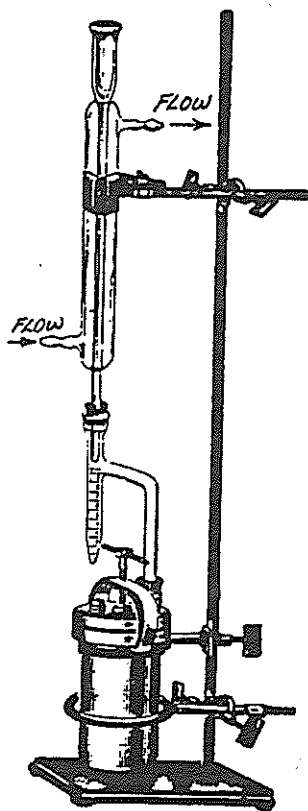

Figure 2 Assembled Apparatus for Moisture Determination

6. PROCEDURE FOR DETERMINATION OF VOLATILE DISTILLATES

Section 6 is not normally applicable to FLH field testing and has been
deliberately omitted.

7. CALCULATIONS

7.1 Calculate the moisture content as follows:

$$\text{Water \%} = \frac{\text{Volume of Water in Trap} \times 100}{\text{Weight of Sample}}$$

7.2 Calculate the moisture content as follows:

$$\text{Water \%} = \frac{\text{Original Weight of Sample} - \text{Final Weight of Sample} \times 100}{\text{Original Weight of Sample}}$$

Note 4 - Report all percentages to the nearest 0.01 percent.

Standard Method of Test for

Slump of Portland Cement Concrete WFLHD Designation: T 119-94 (Modified AASHTO T 119)

1. SCOPE

1.1 This method covers determination of slump of concrete, both in the laboratory and in the field.

Note 1 - This method is considered applicable to plastic concrete having coarse aggregate up to 37.5 mm (1-1/2 in.) in size. If the coarse aggregate is larger than 37.5 mm (1-1/2 in.) in size, the method is applicable when it is made on the fraction of concrete passing a 37.5 mm (1-1/2 in.) sieve with the larger aggregate being removed in accordance with Section 4 of T 141, Sampling Fresh Concrete. This method is not considered applicable to nonplastic and noncohesive concrete.

2. APPARATUS

2.1 **Mold** - The test specimen shall be formed in a mold made of metal not readily attacked by the cement paste. The metal shall not be thinner than No. 16 gage (BWG) and if formed by the spinning process, there shall be no point on the mold at which the thickness is less than 1.14 mm (0.045 in.). The mold shall be in the form of the lateral surface of the frustum of a cone with the base 203.2 mm (8 in.) in diameter, the top 101.6 mm (4 in.) in diameter, and the height 304.8 (12 in.). Individual diameters and heights shall be within ± 3.2 mm (1/8 in.) of the prescribed dimensions. The base and the top shall be open and parallel to each other and at right angles to the axis of the cone. The mold shall be provided with foot pieces and handles similar to those shown in Fig. 1. The mold may be constructed either with or without a seam. When a seam is required, it should be essentially as shown in Fig. 1. The interior of the mold shall be relatively smooth and free from projections such as protruding rivets. The mold shall be free from dents. A mold which clamps to a nonabsorbent base plate is acceptable instead of the one illustrated provided the clamping arrangement is such that it can be fully released without movement of the mold.

2.2 **Tamping Rod** - The tamping rod shall be a round, straight steel rod 15.875 mm (5/8 in.) in diameter and approximately 609.6 mm (24 in.) in length, having the tamping end rounded to a hemispherical tip the diameter of which is 15.875 mm (5/8 in.).

3. SAMPLE

3.1 The sample of concrete from which test specimens are made shall be representative of the entire batch. It shall be obtained in accordance with T 141.

4. PROCEDURE

4.1 Dampen the mold and place it on a flat, moist, nonabsorbent (rigid) surface. It shall be held firmly in place during filling by the operator standing on the two foot pieces. From the sample of concrete obtained in accordance with Section 3, immediately fill the mold in three layers, each approximately one third the volume of the mold.

Note 3 - One third of the volume of the slump mold fills it to a depth of 66.675 mm (2-5/8 in.); two-thirds of the volume fills it to a depth of 155.575 mm (6-1/8 in.).

4.2 Rod each layer with 25 strokes of the tamping rod. Uniformly distribute the strokes over the cross section of each layer. For the bottom layer this will necessitate inclining the rod slightly and making approximately half of the strokes near the perimeter, and then progressing with vertical strokes spirally toward the center. Rod the bottom layer throughout its depth. Rod the second layer and the top layer each throughout its depth, so that the strokes just penetrate into the underlying layer.

4.3 In filling and rodding the top layer, heap the concrete above the mold before rodding is started. If the rodding operation results in subsidence of the concrete below the top edge of the mold, add additional concrete to keep an excess of concrete above the top of the mold at all times. After the top layer has been rodded, strike-off the surface of the concrete by means of a screeding and rolling motion of the tamping rod. Remove the mold immediately from the concrete by raising it carefully in a vertical direction. Raise the mold a distance of 304.8 mm (12 in.) in 5 ± 2 s by a steady upward lift with no lateral or torsional motion. Complete the entire test from the start of the filling through removal of the mold without interruption and complete it within an elapsed time of 2-1/2 min.

4.4 Immediately measure the slump by determining the vertical difference between the top of the mold and the displaced original center of the top surface of the specimen as shown in Fig. 2. If a decided falling away or shearing off of concrete from one side or portion of the mass occurs, disregard the test and make a new test on another portion of the sample.

Note 4 - If two consecutive tests on a sample of concrete show a falling away or shearing off of a portion of the concrete from the mass of the specimen, the concrete probably lacks necessary plasticity and cohesiveness for the slump test to be applicable.

5. REPORT

5.1 Record the slump in terms of millimeters (inches) to the nearest 5 mm (1/4 in.) of subsidence of the specimen during the test as follows:

Slump = 305 - mm of height after subsidence, or
Slump = 12 - inches of height after subsidence.

6. PRECISION

6.1 Data are being compiled and developed that will be suitable for use in developing precision statements for this method.

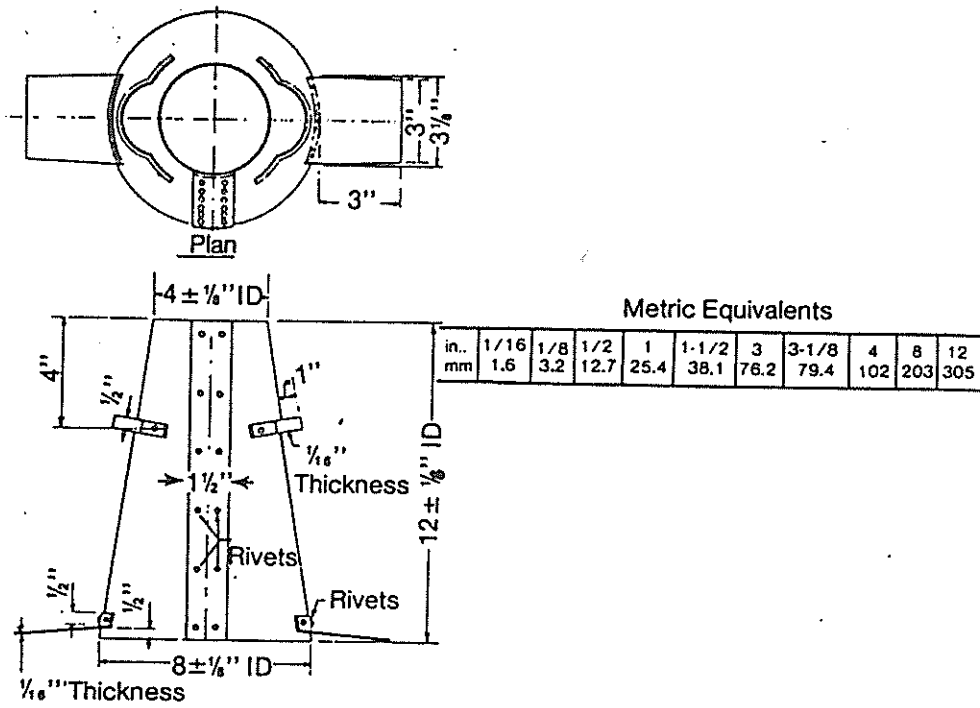

Fig. 1. Mold for Slump test

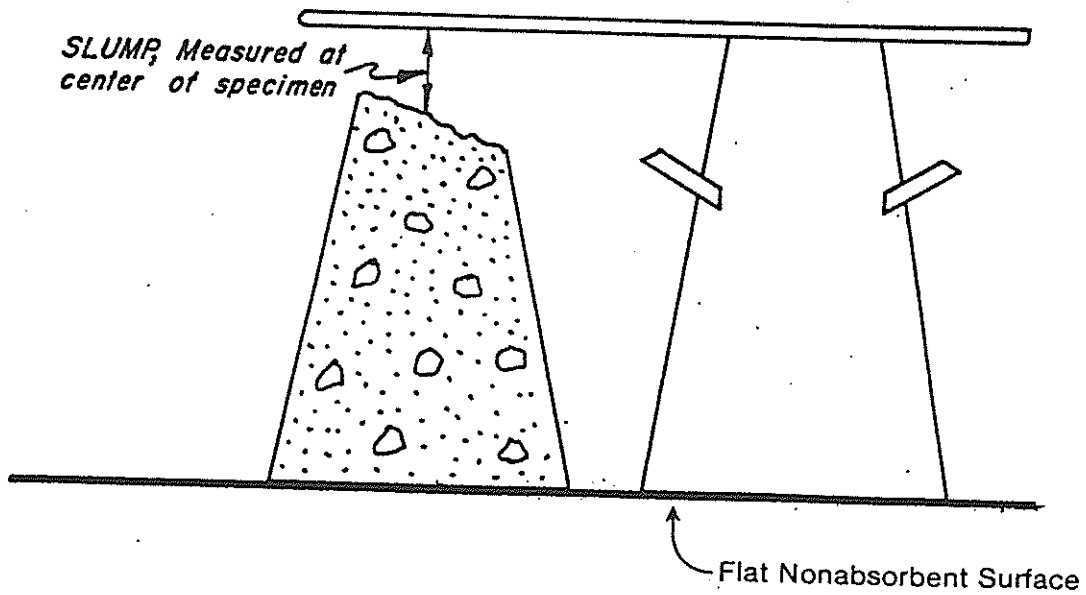

Fig. 2. Mold for Slump Test

(INTENTIONALLY LEFT BLANK)

Standard Method of Test for
Weight Per Cubic Meter (Foot), Yield, and Air Content
(Gravimetric) of Concrete
WFLHD Designation: T 121-94 (Modified AASHTO T 121)

1. SCOPE

1.1 This method covers determination of the weight per cubic meter (or cubic foot) of freshly mixed concrete and gives formulas for calculating the yield, cement content, and the air content of the concrete. Yield is defined as the volume of concrete produced from a mixture of known quantities of the component materials.

2. APPLICABLE DOCUMENTS

2.1 AASHTO Standards:

T 19	Unit Weight of Aggregate
T 141	Sampling Fresh Concrete
T 152	Air Content of Freshly Mixed Concrete by Pressure Method
M 85	Portland Cement
T 133	Specific Gravity of Hydraulic Cement

3. APPARATUS

3.1 **Balance** - A balance or scale accurate to within 0.3% of the test load at any point within the range of use. The range of use shall be considered to extend from the weight of the measure empty to the weight of the measure plus its contents at 2600 kg/m³ (160 lb/ft³).

3.2 **Tamping Rod** - A round, straight steel rod, 15.875 mm (5/8 in.) in diameter and approximately 609.6 mm (24 in.) in length, having the tamping end rounded to a hemispherical tip the diameter of which is 15.875 mm (5/8 in.)

3.3 **Internal Vibrator** - Internal vibrators may have rigid or flexible shafts, preferably powered by electric motors. The frequency of vibrations shall be 7000 vibrations per minute or greater while in use. The outside diameter or the side dimension of the vibrating element shall be at least 19.1 mm (0.75 in.) (19 mm) and not greater than 38.1 mm (1.50 in.). The length of the shaft shall be at least 609.6 mm (24 in.).

3.4 **Measure** - A cylindrical container made from metal that is not readily attacked by cement paste. It shall be watertight and sufficiently rigid to retain its form and calibrated volume under rough usage. Measures that are machined to accurate dimensions on the inside and provided with handles are preferred. The minimum capacity of the measure shall conform to the requirements of Table 1. All measures, except for measuring bowls of air meters which are also used for T 121 tests, shall conform to the requirements of T 19. When measuring bowls of air meters are used, they shall conform to the requirements of T 152. The top rim of the air meter bowls shall be smooth and plane within 0.254 mm (0.01 in.).

Note 1 - The top rim is satisfactorily plane if a 0.254 mm (0.01 in.) feeler gage cannot be inserted between the rim and a piece of 6.35 mm (1/4 in.) or thicker plate glass laid over the top of the measure.

3.5 Strike-Off Plate - A flat rectangular metal plate at least 6.35 mm (1/4 in.) thick or a glass or acrylic plate at least 12.7 mm (1/2 in.) thick with a length and width at least 50.8 mm (2 in.) greater than the diameter of the measure with which it is to be used. The edges of the plate shall be straight and smooth within a tolerance of 1.59 mm (1/16 in.).

3.6 Calibration Equipment - A piece of plate glass, preferably at least 6.35 mm (1/4 in.) thick and at least 25.4 mm (1 in.) larger than the diameter of the measure to be calibrated. A supply of water pump or chassis grease that can be placed on the rim of the container to prevent leakage.

3.7 Mallet - A mallet (with a rubber or rawhide head) weighing approximately 0.57 ± 0.23 kg (1.25 ± 0.50 lb.) for use with measures of $0.0142 m_3$ ($0.5 ft^3$) or smaller, and a mallet weighing approximately 1.02 ± 0.23 kg (2.25 ± 0.50 lb.) for use with measures larger than $0.0142 m_3$ ($0.5 ft^3$).

Table 1 Minimum Capacity of Measures

Maximum Nominal Size of Coarse Aggregate ^a		Capacity of Measure, min ^b	
mm	(in.)	m ³	(ft ³)
25.0	(1)	0.0057	(0.2)
37.5	(1-1/2)	0.0113	(0.4)
50	(2)	0.0142	(0.5)
75	(3)	0.0283	(1.0)
114	(4-1/2)	0.0708	(2.5)
152	(6)	0.0991	(3.5)

^a Aggregate of a given maximum nominal size may contain up to 10% of particles retained on the sieve referred to.

^b To provide for wear, measures may be up to 5% smaller than indicated in this table.

4. CALIBRATION OF MEASURE

4.1 Calibrate the measure and determine the factor used to convert the mass in kilograms or pounds contained in the measure to mass in kilograms per cubic meter or pounds per cubic foot. Follow the procedure outlined in T 19. Measures shall be recalibrated at least once a year or whenever there is reason to question the accuracy of the calibration.

5. SAMPLE

5.1 Obtain the sample of freshly mixed concrete in accordance with T 141.

6. PROCEDURE

6.1 The methods of consolidation are rodding and internal vibration. Rod concretes with a slump greater than 75 mm (3 in.). Rod or vibrate concrete with a slump of 25 to 75 mm (1 to 3 in.). Consolidate concretes with a slump less than 25 mm (1 in.) by vibration.

Note 2 - The nonplastic concrete, such as is commonly used in the manufacture of pipe and on masonry, is not covered by this method.

6.2 **Rodding** - Place the concrete in the measure in three layers or approximately equal volume. Rod each layer with 25 strokes of the tamping rod when the 0.0142m³ (0.5 ft³) or smaller measures are used and 50 strokes when a 0.0283m³ (1 ft³) or larger measure is used. Rod the bottom layer throughout its depth but the rod shall not forcibly strike the bottom of the measure. Distribute the strokes uniformly over the cross section of the measure and for the top two layers, penetrate about 25 mm (1 in.) into the underlying layer. After each layer is rodded, tap the sides of the measure smartly 10 to 15 times with the appropriate mallet (Sec. 3.7) to close any voids left by the tamping rod and to release any large bubbles of air that may have been trapped. Add the final layer so as to avoid overfilling.

6.3 **Internal Vibration** - Fill and vibrate the measure in two approximately equal layers. Place all of the concrete for each layer in the measure before starting vibration of that layer. Insert the vibrator at three different points for each layer. In compacting the bottom layer, do not allow the vibrator to rest on or touch the bottom or sides of the measure. In compacting the final layer, the vibrator shall penetrate into the underlying layer approximately 25 mm (1 in.). Take care that the vibrator is withdrawn in such a manner that no air pockets are left in the specimen. The duration of vibration required will depend upon the workability of the concrete and the effectiveness of the vibrator. Continue vibration only long enough to achieve proper consolidation of the concrete. Observe a constant duration of vibration for the particular kind of concrete, vibrator, and measure involved.

Note 3 - Usually, sufficient vibration has been applied as soon as the surface of the concrete becomes relatively smooth.

Note 4 - Overvibration may cause segregation and loss of appreciable quantities of intentionally entrained air.

6.4 On completion of consolidation the measure must not contain a substantial excess or deficiency of concrete. An excess of concrete protruding approximately 3 mm (1/8 in.) above the top of the mold is optimum. A small quantity of concrete may be added to correct a deficiency. If the measure contains a great excess of concrete at completion of consolidation, remove a representative portion of the excess concrete with a trowel or scoop immediately following completion of consolidation and before the measure is struck-off.

6.5 **Strike-Off** - After consolidation, strike-off the top surface of the concrete and finish it smoothly with the flat strike-off plate using great care to leave the measure just level full. The strike-off is best accomplished by pressing the strike-off plate on the top surface of the measure to cover about two-thirds of the surface and withdrawing the plate with a sawing motion to

finish only the area originally covered. Then place the plate on the top of the measure to cover the original two-thirds of the surface and advance it with a vertical pressure and a sawing motion to cover the whole surface of the measure. Several final strokes with the inclined edge of the plate will produce a smooth finished surface.

6.6 Cleaning and Weighing - After strike-off, clean all excess concrete from the exterior of the measure and determine the net mass of the concrete in the measure to an accuracy consistent with the requirements of 3.1.

7. CALCULATIONS

7.1 Unit Weight - Calculate the net mass of the concrete in kilograms (or pounds) by subtracting the mass of the measure from the gross mass. Calculate the mass per cubic meter (or cubic foot) by multiplying the net mass by the calibration factor for the measure used, determined according to T 19.

7.2 Yields - Calculate the yield, Y , (volume of concrete produced per batch) by dividing the total mass of all materials batched, W_t , by the density, W , determined in 7.1. The total mass of all materials batched is the sum of the mass of the cement, the fine aggregate in the condition used, the coarse aggregate in the condition used, the mixing water added to the batch and any other solid or liquid materials used.

7.3 Relative Yield - Relative yield is the ratio of the actual volume of concrete obtained to the volume as designed for the batch calculated as follows:

$$R_y = Y/Y_d$$

Where:

R_y = relative yield, and

Y_d = volume of concrete which the batch was designed to produce, m^3 ($yd.^3$).

Y = Volume of batch in m^3 ($yd.^3$).

Note 5 - A value for R_y greater than 1.00 indicates an excess of concrete being produced whereas a value less than this indicates the batch to be "short" of its designed volume.

7.4 Cement Content - Calculate the actual cement content as follows:

$$N = N_t/Y$$

Where:

N = actual cement content, kg/m^3 and (lb/yd^3)

N_t = mass of cement in the batch, kg . (lb).

Y = Volume of batch in m^3 ($yd.^3$).

7.5 Air Content - Calculate the air content as follows:

$$A = [(T-W)/T] \times 100$$

or

$$A = [(Y-V)/Y] \times 100$$

Where:

- A = air content (percentage of voids) in the concrete,
T = theoretical weight of the concrete computed on an airfree basis,
kg/m³ (lb/ft³),
W = unit weight of concrete, kg/m³ and (lb/ft³),
V = total absolute volume of the component ingredients in the batch,
m³ (ft³) .
Y = Volume of batch in m³ (yd³) .

Note 6 - The theoretical density per cubic meter (or cubic foot) is, customarily, a laboratory determination, the value for which is assumed to remain constant for all batches made using identical component ingredients and proportions. It is calculated from the equation:

$$T = W_1/V$$

The absolute volume of each ingredient in cubic meters is equal to the mass of the ingredient in kilograms divided by 1000 times its specific gravity. The absolute volume of each ingredient in cubic feet is equal to the quotient of the mass of that ingredient divided by the product of its specific gravity times 62.4. For the aggregate components, the bulk specific gravity and mass should be based on the saturated, surface-dry condition. For cement, the actual specific gravity should be determined by AASHTO T 133. A value of 3.15 may be used for cements manufactured to meet the requirements of AASHTO M 85.

8. PRECISION

8.1 Data are being compiled and developed that will be suitable for use in developing precision statements for this method.

(INTENTIONALLY LEFT BLANK)

Standard Method of

Sampling Fresh Concrete

WFLHD Designation: T 141-94 (Modified AASHTO T 141)

1. SCOPE

1.1 This method describes the procedures for obtaining representative samples of fresh concrete as delivered to the project site and on which tests are to be performed to determine compliance with quality requirements of the specifications under which the concrete is furnished. The method includes sampling from stationary, paving, and truck mixers, and from agitating and nonagitating equipment used to transport central mixed concrete.

Note 1 - Composite samples are permitted by this method, unless specifically exempted by procedures governing the tests to be performed such as tests to determine uniformity of consistency and mixer efficiency. Procedures used to select the specific test batches are not described in this method, but it is recommended that random sampling be used to determine overall specification compliance.

1.2 This method also covers the procedures to be used for preparing a sample of concrete for further testing where it is desirable or necessary to remove the aggregate larger than a designated size. This removal of larger aggregate particles is preferably accomplished by wet-sieving.

2. SAMPLING

2.1 The elapsed time between obtaining the first and final portions of composite samples shall be as short as possible, but in no instance shall it exceed 15 min.

2.1.1 Transport the individual samples to the place where fresh concrete tests are to be performed or where test specimens are to be molded. They shall then be combined and remixed with a shovel the minimum amount necessary to ensure uniformity.

2.1.2 Start tests for slump or air content, or both, within 5 min. after the sampling is completed. Complete these tests as expeditiously as possible. Start molding specimens for strength tests within 15 min. after fabricating the composite sample. Keep the elapsed time between obtaining and using the sample as short as possible and protect the sample from the sun, wind, and other sources of rapid evaporation, and from contamination.

3. PROCEDURE

3.1 **Size of Sample** - Make the samples to be used for strength tests a minimum of 28 liters (1 ft.³). Smaller samples may be permitted for routine air content and slump tests and the size shall be dictated by the maximum aggregate size.

3.2 The procedures used in sampling shall include the use of every precaution that will assist in obtaining samples that are truly representative of the nature and condition of concrete sampled as follows:

Note 2 - Sampling should normally be performed as the concrete is delivered from the mixer to the conveying vehicle used to transport the concrete to the forms; however, specifications may require other points of sampling, such as at the discharge of a concrete pump.

Note 3 - As routine air content and slump tests are not readily adaptable to sampling the concrete at two or more regularly spaced intervals during discharge of the middle portion of the batch as specified in this method, the sample for air content, slump, and temperature may be taken after at least two cubic feet of concrete has been discharged. The material obtained and used for determining air content and/or slump shall not be remixed and incorporated into the molded specimens.

3.2.1 Sampling from Stationary Mixers, Except Paving Mixers - Sample the concrete at one or more regularly spaced intervals during discharge of the middle portion of the batch. Take the material, so obtained, within the time limit specified in Section 2, and if appropriate, composite them into one sample for test purposes. Do not obtain samples from the very first or last portions of the batch discharge. Perform sampling by passing a receptacle completely through the discharge stream, or by completely diverting the discharge into a sample container. If discharge of the concrete is too rapid to divert the complete discharge stream, discharge the concrete into a container or transportation unit sufficiently large to accommodate the entire batch and then accomplish the sampling in the same manner as given above. Take care not to restrict the flow of concrete from the mixer, container, or transportation unit so as to cause segregation. These requirements apply to both tilting and nontilting mixers.

3.2.2 Sampling from Paving Mixers - Sample the concrete after the contents of the paving mixer have been discharged. Obtain samples from at least three different portions of the pile within the time limit specified in Section 2, and then composite into one sample for test purposes. Avoid contamination with subgrade material or prolonged contact with an absorptive subgrade. To preclude contamination or absorption by the subgrade, the concrete may be sampled by placing three shallow containers on the subgrade and discharging the concrete across the containers. Composite the samples so obtained into one sample for test purposes. The containers shall be of a size sufficient to provide a composite sample size that is in agreement with the maximum aggregate size.

Note 4 - In some instances, the containers may have to be supported above the subgrade to prevent displacement during discharge.

3.2.3 Sampling from Revolving Drum Truck Mixers or Agitators - Sample the concrete at one or more regularly spaced intervals during discharge of the middle portion of the batch. Take the samples so obtained within the time limit specified in Section 2 and if applicable composite them into one sample for test purposes. In any case do not obtain samples until after all of the water has been added to the mixer; also do not obtain samples from the very first or last portions of the batch discharge. Sample by repeatedly passing a receptacle through the entire discharge stream or by completely diverting the discharge into a sample container. Regulate the rate of discharge of the batch by the rate of revolution of the drum and not by the size of the gate opening.

3.2.4 Sampling from Open-Top Truck Mixers, Agitators, Nonagitating Equipment, or Other Types of Open-Top Containers - Take samples by whichever of the procedures described in 3.2.1, 3.2.2, or 3.2.3 is most applicable under the given conditions.

4. -ADDITIONAL PROCEDURE FOR LARGE MAXIMUM SIZE AGGREGATE CONCRETE

4.1 When the concrete contains aggregate larger than that appropriate for the size of the molds or equipment to be used, wet-sieve the sample as described below except make unit-weight tests for use in yield computations on the full mix.

Note 5 - The effect of wet-sieving on the test results should be considered. For example, wet-sieving concrete causes the loss of a small amount of air due to additional handling. The air content of the wet-sieved fraction of concrete is greater than that of the total concrete because the larger size aggregate which is removed does not contain air. The apparent strength of wet-sieved concrete in smaller specimens is usually greater than that of the total concrete in larger appropriate size specimens. The effect of these differences may need to be considered or determined by supplementary testing for quality control or test result evaluation purposes.

4.2 Definition:

4.2.1 **Wet-Sieving Concrete** - The process of removing aggregate larger than a designated size from the fresh concrete by sieving it on a sieve of the designated size.

4.3 Apparatus:

4.3.1 Sieves, as designated, conforming to AASHTO M 92 for Wire-Cloth Sieves for Testing Purposes.

4.3.2 **Wet-Sieving Equipment** - Equipment for wet-sieving concrete shall be a sieve as noted in 4.3.1 of suitable size and conveniently arranged and supported so that one can shake it rapidly by either hand or mechanical means. Generally, a horizontal back and forth motion is preferred. The equipment shall be capable of rapidly and effectively removing the designated size of aggregate.

4.3.3 **Hand Tools** - Shovels, hand scoops, plastering trowels, and rubber gloves as required.

Note 6 - The ASTM Manual of Concrete Testing gives descriptions and pictures of several pieces of equipment which have proven satisfactory for the purpose.

4.4 Procedure:

4.4.1 **Wet Sieving** - After sampling the concrete, pass the concrete over the designated sieve and remove and discard the aggregate retained. This shall be done before remixing. Shake or vibrate the sieve by hand or mechanical means until no undersize material remains on the sieve. Mortar adhering to the aggregate retained on the sieve shall not be wiped from it before it is discarded. Place only enough concrete on the sieve at any one time so that after

sieving, the thickness of the layer of retained aggregate is not more than one particle thick. The concrete which passes the sieve shall fall into a batch pan of suitable size which has been dampened before use or onto a clean, moist, nonabsorbent surface. Scrape any mortar adhering to the sides of the wet-sieving equipment into the batch. After removing the larger aggregate particles by wet-sieving remix the batch with a shovel the minimum amount necessary to ensure uniformity and proceed testing immediately.

Standard Method of Test for
Air Content of Freshly Mixed Concrete
by the Pressure Method
WFLHD Designation: T 152-94 (Modified AASHTO T 152)

1. SCOPE

1.1 This method covers determination of the air content of freshly mixed concrete from observation of the change in volume of concrete with a change in pressure.

1.2 This method is intended for use with concretes and mortars made with relatively dense aggregates for which the aggregate correction factor can be satisfactorily determined by the technique described in Section 5. It is not applicable to concretes made with light-weight aggregates, air-cooled blast-furnace slag, or aggregates of high porosity. In these cases, AASHTO T 196, should be used.

2. APPLICABLE DOCUMENTS

2.1 AASHTO Standards:

- T 119 Slump of Portland Cement Concrete
- T 121 Weight Per Cubic Foot, Yield, and Air Content
(Gravimetric) of Concrete
- T 126 Making and Curing Concrete Test Specimens in the Laboratory
- T 141 Sampling Freshly Mixed Concrete
- T 196 Air Content of Freshly Mixed Concrete by the Volumetric Method
- M 231 Weights and Balances Used in the Testing of Highway Materials

3. APPARATUS

3.1 Air Meters - There are available satisfactory apparatus of two basic operational designs employing the principle of Boyle's law. For purposes of reference herein these are designated Meter Type A and Meter Type B.

3.1.1 Meter Type A - An air meter consisting of a measuring bowl and cover assembly (see Fig. 1) conforming to the requirements of 3.2 and 3.3. The operational principle of this meter consists of introducing water to a predetermined height above a sample of concrete of known volume, and the application of a predetermined air pressure over the water. The determination consists of the reduction in volume of the air in the concrete sample by observing the amount the water level is lowered under the applied pressure, the latter amount being calibrated in terms of percent of air in the concrete sample.

3.1.2 Meter Type B - An air meter consisting of a measuring bowl and cover assembly (see Fig. 2) conforming to the requirements of 3.2 and 3.3. The operational principle of this meter consists of equalizing a known volume of air at a known pressure in a sealed air chamber with the unknown volume of air in the concrete sample, the dial on the pressure gage being calibrated in terms of percent air for the observed pressure at which equalization takes place. Working pressures of 51 to 207 kPa (7.5 to 30.0 psi) have been used satisfactorily.

3.2 Measuring Bowl - The measuring bowl shall be essentially cylindrical in shape, made of steel or other hard metal not readily attacked by the cement paste, having a minimum diameter equal to 0.75 to 1.25 times the height, and a capacity of at least 0.0057m^3 (0.20ft^3). It shall be flanged or otherwise constructed to provide for a pressure tight fit between bowl and cover assembly. The interior surfaces of the bowl and surfaces of rims, flanges, and other component fitted parts shall be machined smooth. The measuring bowl and cover assembly shall be sufficiently rigid to limit the expansion factor, D, of the apparatus assembly (Appendix X5) to not more than 0.1% of air content on the indicator scale when under normal operating pressure.

3.3 Cover Assembly:

3.3.1 The cover assembly shall be made of steel or other hard metal not readily attacked by the cement paste. It shall be flanged or otherwise constructed to provide for a pressure-tight fit between bowl and cover assembly and shall have machined smooth interior surfaces contoured to provide an air space above the level of the top of the measuring bowl. The cover shall be sufficiently rigid to limit the expansion factor of the apparatus assembly as prescribed in 3.2.

3.3.2 The cover assembly shall be fitted with a means of direct reading of the air content. The cover for the Type A meter shall be fitted with a standpipe, which may be a transparent graduated tube or may be a metal tube of uniform bore with a glass water gage attached. In the Type B meter, the dial of the pressure gage shall be calibrated to indicate the percent of air. Graduations shall be provided for a range in air content of at least 8% easily readable to 0.1% as determined by the proper air pressure calibration test.

3.3.3 The cover assembly shall be fitted with air valves, air bleeder valves, and petcocks for bleeding off or through which water may be introduced as necessary for the particular meter design. Suitable means for clamping the cover to the bowl shall be provided to make a pressure-tight seal without entrapping air at the joint between the flanges of the cover and bowl. A suitable hand pump shall be provided with the cover either as an attachment or as an accessory.

3.4 Calibration Vessel - A measure having an internal volume equal to a percent of the volume of the measuring bowl corresponding to the approximate percent of air in the concrete to be tested, or, if smaller, it shall be possible to check calibration of the meter indicator at the approximate percent of air in the concrete to be tested by repeated filling of the measure. When the design of the meter requires placing the calibration vessel within the measuring bowl to check calibration, the measure shall be cylindrical in shape and of an inside depth 12.7mm (1/2 in.) less than that of the bowl. A satisfactory measure of this type may be machined from No. 16 gage brass tubing, of a diameter to

provide the volume desired, to which a brass disk 12.7 mm (1/2 in.) in thickness is soldered to form an end. When design of the meter requires withdrawing of water from the water-filled bowl and cover assembly to check calibration, the measure may be an integral part of the cover assembly or may be a separate cylindrical measure similar to the above described cylinder.

3.5 The designs of various available types of air meters are such that they differ in operating techniques and therefore, all of the items described in 3.6 through 3.14 may not be required. The items required shall be those necessary for use with the particular design of apparatus used to satisfactorily determine air content in accordance with the procedures prescribed herein.

3.6 Coil Spring or Other Device for Holding Calibration Cylinder in Place.

3.7 Spray Tube - A brass tube of appropriate diameter, which may be an integral part of the cover assembly or which may be provided separately. It shall be so constructed that when water is added to the container, it is sprayed to the walls of the cover in such a manner as to flow down the sides causing a minimum of disturbance to the concrete.

3.8 Trowel - A standard brick mason's trowel.

3.9 Tamping Rod - As described in AASHTO T 119.

3.10 Mallet - A mallet (with a rubber or rawhide head) weighing approximately 0.57 ± 0.23 kg (1.25 ± 0.50 lb.) for use with measures of 0.0142m^3 (0.5 ft^3) or smaller, and a mallet weighing approximately 1.02 ± 0.23 kg (2.25 ± 0.50 lb.) for use with measures larger than 0.0142m^3 (0.5 ft^3).

3.11 Strike-Off Bar - A flat straight bar of steel or other suitable metal.

3.12 Funnel - Funnel with the spout fitting into stray tube.

3.13 Measure for Water - Measure for Water having the necessary capacity to fill the indicator with water from the top of the concrete to the zero mark.

3.14 Vibrator - As described in AASHTO T 126.

3.15 Sieves - Sieves, 37.5 mm (1-1/2 in.) with not less than 0.186 m^2 (2 ft^2) of sieving area.

4. CALIBRATION OF APPARATUS

4.1 Make calibration tests in accordance with procedures prescribed in the appendix. Rough handling will affect the calibration of both Types A and B meters. Changes in barometric pressure will affect the calibration of Type A meter but not Type B meter. The steps described in X1.2 to X1.6, as applicable to the meter type under consideration, are prerequisites for the final calibration test to determine the operating pressure, P, on the pressure gage of the Type A meter as described in X1.7, or to determine the accuracy of the graduations indicating air content on the dial face of the pressure gage of the Type B meter. Normally the steps in X1.2 to X1.6 need be made only once (at the time of initial calibration), or only occasionally to check volume constancy of

the calibration cylinder and measuring bowl. On the other hand, the calibration test described in X1.7 and X1.9, as applicable to the meter type being checked, must be made as frequently as necessary to ensure that the proper gage pressure, P, is being used for the Type A meter or that the correct air contents are being indicated on the pressure gage air content scale for the Type B meter. A change in elevation of more than 183 m (600 ft.) from the location at which a Type A meter was last calibrated will require recalibration in accordance with X1.7.

5. DETERMINATION OF AGGREGATE CORRECTION FACTOR

5.1 Procedure - Determine the aggregate correction factor on a combined sample of fine and coarse aggregate as directed in 5.2 to 5.4. It is determined independently by applying the calibrated pressure to a sample of inundated fine and coarse aggregate in approximately the same moisture condition, amount, and proportions occurring in the concrete sample under test.

5.2 Aggregate Sample Size - Calculate the weights of fine and coarse aggregate present in the sample of fresh concrete whose air content is to be determined, as follows:

$$F_s = (S/B) \times F_b \quad (1)$$

$$C_s = (S/B) \times C_b \quad (2)$$

Where:

F_s = weight of fine aggregate in concrete sample under test, kg (lb.)
 S = volume of concrete sample (same as volume of measuring bowl), m^3 (ft^3),
 B = volume of concrete produced per batch (Note 3), m^3 (ft^3),
 F_b = total weight of fine aggregate in the moisture condition used in batch, kg (lb.),
 C_s = weight of coarse aggregate in concrete sample under test, kg (lb.), and
 C_b = total weight of coarse aggregate in the moisture condition used in batch, kg (lb.).

Note 1 - The volume of concrete produced per batch can be determined in accordance with applicable provisions of AASHTO T 121.

Note 2 - The term "weight" is temporarily used in this standard because of established trade usage. The work is used to mean both "force" and "mass," and care must be taken to determine which is meant in each case (SI unit for force = newton and for mass = kilogram).

5.3 Placement of Aggregate in Measuring Bowl - Mix representative samples of fine aggregate F_s , and coarse aggregate C_s , and place in the measuring bowl filled one-third full with water. Place the mixed aggregate, a small amount at a time, into the measuring bowl; if necessary, add additional water so as to inundate all of the aggregate. Add each scoopful in a manner that will entrap as little air as possible and remove accumulations of foam promptly. Tap the sides of the bowl and lightly rod the upper 25 mm (1 in.) of the aggregate about ten times. Stir after each addition of aggregate to eliminate entrapped air.

5.4 Aggregate Correction Factor Determination:

5.4.1 Initial Procedure for Types A and B Meters - When all of the aggregate has been placed in the measuring bowl, remove excess foam and keep the aggregate inundated for a period of time approximately equal to the time between introduction of the water into the mixer and the time of performing the test for air content before proceeding with the determination as directed in 5.4.2 or 5.4.3.

5.4.2 Type A Meter - Complete the test as described in 7.2.1 and 7.2.2. The aggregate correction factor, G , is equal to $h_1 - h_2$ (see Fig. 1).

5.4.3 Type B Meter - Perform the procedures as described in 7.3.1. Remove a volume of water from the assembled and filled apparatus approximately equivalent to the volume of air that would be contained in a typical concrete sample of a size equal to the volume of the bowl. Remove the water in the manner described in X1.9 of the appendix for the calibration tests. Complete the test as described in 7.3.2. The aggregate correction factor, G , is equal to the reading on the air-content scale minus the volume of water removed from the bowl expressed as a percent of the volume of the bowl (see Fig. 1).

Note 3 - The aggregate correction factor will vary with different aggregates. It can be determined only by test, since apparently it is not directly related to absorption of the particles. The test can be easily made and must not be ignored. Ordinarily the factor will remain reasonably constant for given aggregates, but an occasional check test is recommended.

6. PREPARATION OF CONCRETE TEST SAMPLE

6.1 Obtain the sample of freshly mixed concrete in accordance with applicable procedures of AASHTO T 141. If the concrete contains coarse aggregate particles that would be retained on a 50 mm (2 in.) sieve, wet sieve a sufficient amount of the representative sample over a 37.5 mm (1-1/2 in.) sieve, as described in AASHTO T 141 to yield somewhat more than enough material to fill the measuring bowl of the size selected for use. Carry out the wet sieving operation with the minimum practicable disturbance of the mortar. Make no attempt to wipe adhering mortar from coarse aggregate particles retained on the sieve.

7. PROCEDURE FOR DETERMINING AIR CONTENT OF CONCRETE

7.1 Placement and Consolidation of Sample:

7.1.1 Place a representative sample of the concrete, prepared as described in Section 6, in the measuring bowl in equal layers. Consolidate each layer by the rodding procedure (7.1.2) or by vibration (7.1.3). Strike-off the finally consolidated layer (7.1.4). Vibration shall not be employed to consolidate concrete having a slump greater than 76 mm (3 in.).

7.1.2 Rodding - Place the concrete in the measuring bowl in three layers of approximately equal volume. Consolidate each layer of concrete by 25 strokes of tamping rod evenly distributed over the cross section. After each layer is rodded, tap the sides of the measure smartly 10 to 15 times with the mallet to close any voids left by the tamping rod and to release any large bubbles of air that may have been trapped. Rod the bottom layer throughout its depth, but the

rod shall not forcibly strike the bottom of the measure. In rodding the second and final layers, use only enough force to cause the rod to penetrate the surface of the previous layer about 25 mm (1 in.). Add the final layer of concrete in a manner to avoid excessive overfilling (7.1.4).

7.1.3 Vibration - Place the concrete in the measuring bowl in two layers of approximately equal volume. Place all of the concrete for each layer before starting vibration of that layer. Consolidate each layer by three insertions of the vibrator evenly distributed over the cross section. Add the final layer in a manner to avoid excessive overfilling (7.1.4). In consolidating the bottom layer, do not allow the vibrator to rest on or touch the bottom or sides of the measuring bowl. Take care in withdrawing the vibrator to ensure that no air pockets are left in the specimen. Observe a standard duration of vibration for the particular kind of concrete, vibrator, and measuring bowl involved. The duration of vibration required will depend upon the workability of the concrete and the effectiveness of the vibrator. Continue vibration only long enough to achieve proper consolidation of the concrete. Overvibration may cause segregation and loss of intentionally entrained air. Usually, sufficient vibration has been applied as soon as the surface of the concrete becomes relatively smooth and has a glazed appearance. Never continue vibration long enough to cause escape of froth from the sample.

7.1.4 Strike-Off - After consolidation of the concrete, strike-off the top surface by sliding the strike-off bar across the top flange or rim of the measuring bowl with a sawing motion until the bowl is just level full. On completion of consolidation, the bowl must not contain a great excess or deficiency of concrete. Removal of approximately 3 mm (1/8 in.) during strike-off is optimum. A small quantity of representative concrete may be added to correct a deficiency. If the measure contains a great excess, remove a representative portion of concrete with a trowel or scoop before the measure is struck-off.

7.1.5 Application of Test Method - Any portion of the test method not specifically designated as pertaining to Type A or Type B meter shall apply to both types.

7.2 Procedure - Type A Meter:

7.2.1 Preparation for Test - Thoroughly clean the flanges or rims of the bowl and of the cover assembly so that when the cover is clamped in place a pressure-tight seal will be obtained. Assemble the apparatus and add water over the concrete by means of the tube until it rises to about the halfway mark in the standpipe. Incline the apparatus assembly about 30° from vertical and, using the bottom of the bowl as a pivot, describe several complete circles with the upper end of the column, simultaneously tapping the cover lightly to remove any entrapped air bubbles above the concrete sample. Return the apparatus assembly to a vertical position and fill the water column slightly above the zero mark, while lightly tapping the sides of the bowl. Remove foam on the surface of the water column with a syringe or with a spray of alcohol to provide a clear meniscus. Bring the water level to the zero mark of the graduated tube before closing the vent at the top of the water column (see Fig. 1 A).

Note 4 - The internal surface of the cover assembly should be kept clean and free from oil or grease; the surface should be wet to prevent adherence of air bubbles that might be difficult to dislodge after assembly of the apparatus.

7.2.2 Test Procedure - Apply slightly more than the desired test pressure, P , [about 1380 Pa (0.2 psi) more] to the concrete by means of the small hand pump. To relieve local restraints, tap the sides of the measure sharply and, when the pressure gage indicates the exact test pressure, P , as determined in accordance with X1.7, read the water level, h_1 , and record to the nearest division or half-division on the graduated precision-bore tube or gage glass of the standpipe (see Fig. 1 B). For extremely harsh mixes, it may be necessary to tap the bowl vigorously until further tapping produces no change in the indicated air content. Gradually release the air pressure through the vent at the top of the water column and tap the sides of the bowl lightly for about 1 min. Record the water level, h_2 , to the nearest division or half-division (see Fig. 1 C). The apparent air content, A_1 , is equal to $h_1 - h_2$.

7.2.3 Check Test - Repeat the steps described in 7.2.2 without adding water to reestablish the water level at the zero mark. The two consecutive determinations of apparent air content should check within 0.2% of air and shall be averaged to give the value A_1 to be used in calculating the air content, A_s , in accordance with Section 8.

7.2.4 In the event the air content exceeds the range of the meter when it is operated at the normal test pressure, P , reduce the test pressure to the alternative test pressure P_1 and repeat the steps outlined in 7.2.2 and 7.2.3.

Note 5 - See X1.7 for exact calibration procedures. An approximate value of the alternative pressure, P_1 , such that the apparent air content will equal twice the meter reading can be computed from the following relationship:

$$P_1 = P_a P / (2P_a + P)$$

Where:

P_1 = alternative test pressure, kPa (psi),
 P_a = atmospheric pressure, kPa (psi) [approximately 101 kPa (14.7 psi) but will vary with altitude and weather conditions], and
 P = normal test or operating gage pressure, kPa (psi).

7.3 Procedure - Type B Meter.

7.3.1 Preparation for Test - Thoroughly clean the flanges or rims, of the bowl and the cover assembly so that when the cover is clamped in place a pressure-tight seal will be obtained. Assemble the apparatus. Close the air valve between the air chamber and the measuring bowl and open both petcocks on the holes through the cover. Using a rubber syringe, inject water through one petcock until water emerges from the opposite petcock. Jar the meter gently until all air is expelled from this same petcock.

7.3.2 Test Procedure - Close the air bleeder valve on the air chamber and pump air into the air chamber until the gage hand is on the initial pressure line. Allow a few seconds for the compressed air to cool to normal temperature. Stabilize the gage hand at the initial pressure line by pumping or bleeding-off

air as necessary, tapping the gage lightly. Close both petcocks on the holes through the cover. Open the air valve between the air chamber and the measuring bowl. Tap the sides of the measuring bowl sharply to relieve local restraints. Lightly tap the pressure gage to stabilize the gage hand and read the percentage of air on the dial of the pressure gage. Release the pressure by opening both petcocks (Fig. 2, A and B) before removing the cover.

Note 6 - Failure to close the main air valve before releasing the pressure from either the container or the air chamber will result in water being drawn into the air chamber thus introducing error in subsequent measurements. In the event water enters the air chamber it must be bled from the air chamber through the bleeder valve followed by several strokes of the pump to blow out the last traces of water.

8. CALCULATION

8.1 Air Content of Sample Tested - Calculate the air content of the concrete in the measuring bowl as follows:

$$A_s = A_1 - G \quad (3)$$

Where:

A_s = air content of sample tested, percent,
 A_1 = apparent air content of the sample tested, % (see 7.2.2 and 8.3.2), and
 G = aggregate correction factor, % (Section 5).

8.2 Air Content of Full Mixture - When the sample tested represents that portion of the mixture that is obtained by wet sieving to remove aggregate particles larger than a 37.5 mm (1-1/2 in.) sieve, the air content of the full mixture may be calculated as follows:

$$A_t = 100 A_s V_c / (100 V_t - A_s V_a) \quad (4)$$

Where: (Note 7)

A_t = air content of the full mixture, percent,
 V_c = absolute volume of the ingredients of the mixture passing a 37.5 mm (1-1/2 in.) sieve, airfree, as determined from the original batch weights, m^3 (ft^3),
 V_t = absolute volume of all ingredients of the mixture, airfree, m^3 (ft^3), and
 V_a = absolute volume of the aggregate in the mixture coarser than a 37.5 mm (1-1/2 in.) sieve, as determined from original batch weights, m^3 (ft^3).

8.3 Air Content of the Mortar Fraction - When it is desired to know the air content of the mortar fraction of the mixture, calculate it as follows:

$$A_m = 100 A_s V_c / [100 V_m + A_s (V_c - V_m)] \quad (5)$$

Where:

A_m = air content of the mortar fraction, %, and
 V_m = absolute volume of the ingredients of the mortar fraction of the mixture, airfree, m^3 (ft^3).

Note 7 - The values for use in Eqs. 4 and 5 are most conveniently obtained from data on the concrete mixture tabulated as follows for a batch of any size:

Cement
 Water
 Fine aggregate
 Coarse aggregate [4.75 mm (No. 4) to 37.5 mm (1-1/2 in.)]
 Coarse aggregate 37.5 mm (1-1/2 in.)
 Total

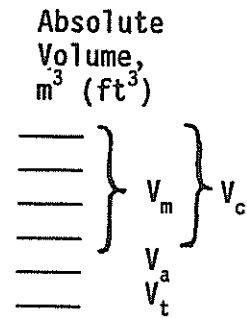

9. PRECISION

9.1 Data is being compiled and developed that will be suitable for use in developing precision statements for this method.

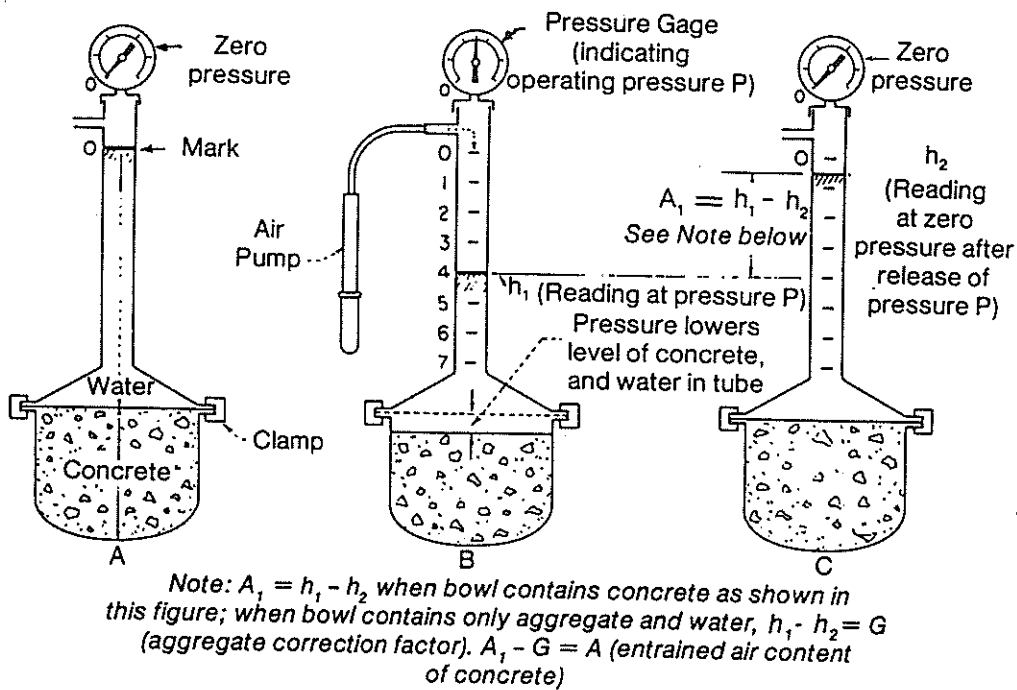

Fig. 1. Illustration of the Pressure Method for Air Content—Type-A Meter

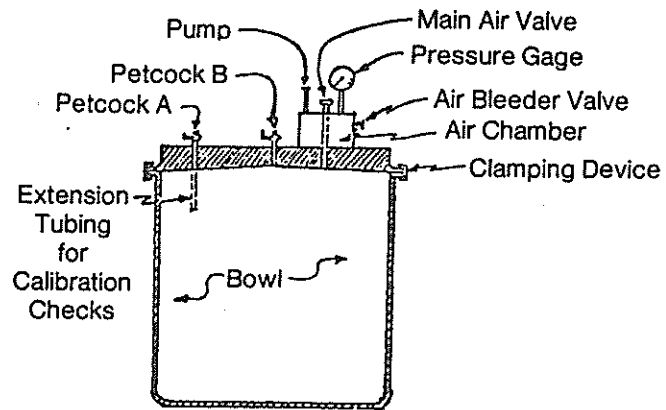

Fig. 2. Schematic Diagram—Type-B Meter

APPENDIX

X1. CALIBRATION OF APPARATUS

X1.1 Calibration tests shall be performed in accordance with the following procedures as applicable to the meter type being employed.

X1.2 Calibration of the Calibration Vessel - Determine accurately the weight of water, w , required to fill the calibration vessel, using a scale which meets Class G 20 of M 231. This step shall be performed for Type A and B meters.

X1.3 Calibration of the Measuring Bowl - Determine the weight of water, W , required to fill the measuring bowl, using the scale which meets Class G 20 of M 231. Slide a glass plate carefully over the flange of the bowl in a manner to ensure that the bowl is completely filled with water. A thin film of cup grease smeared on the flange of the bowl will make a watertight joint between the glass plate and the top of the bowl. This step shall be performed for Type A and B meters.

X1.4 Effective Volume of the Calibration Vessel R - The constant R represents the effective volume of the calibration vessel expressed as a percentage of the volume of the measuring bowl.

X1.4.1 For meter Types A, calculate R as follows:

$$R = 0.98 w/W \quad (X1)$$

Where:

w = weight of water required to fill the calibration vessel, and
 W = weight of water required to fill the measuring bowl.

X1.4.2 For meter Types B calculate R as follows:

$$R = w/W \quad (X2)$$

Note X1 - The factor 0.98 is used to correct for the reduction in the volume of air in the calibration vessel when it is compressed by a depth of water equal to the depth of the measuring bowl. This factor is approximately 0.98 for a 203 mm (8 in.) deep measuring bowl at sea level. Its value decreases to approximately 0.975 at 1524 m (5000 ft.) above sea level and 0.970 at 3962 m (13,000 ft.) above sea level. The value of this constant will decrease by about 0.01 for each 101.6 mm (4 in.) increase in bowl depth. The depth of the measuring bowl and atmospheric pressure do not affect the effective volume of the calibration vessel for meter types B.

X1.5 Determination of, or Check of, Allowance for Expansion Factor D:

X1.5.1 For meter assemblies of Type A determine the expansion factor, D, by filling the apparatus with water only (making certain that all entrapped air has been removed and the water level is exactly on the zero mark and applying an air pressure approximately equal to the operating pressure, P, determined by the calibration test described in X1.7. The amount the water column lowers will be the equivalent expansion factor, D, for that particular apparatus and pressure.

Note X2 - Although the bowl, cover, and clamping mechanism of the apparatus must of necessity be sturdily constructed so that it will be pressure-tight, the application of internal pressure will result in a small increase in volume. This expansion will not affect the test results because, with the procedure described in Sections 5 and 7, the amount of expansion is the same for the test for air in concrete as for the test for aggregate correction factor on combined fine and coarse aggregates, and is thereby automatically cancelled. However, it does enter into the calibration test to determine the air pressure to be used in testing fresh concrete.

Note X3 - The water columns on some meters of Type A design are marked with an initial water level and a zero mark, the difference between the two marks being the allowance for the expansion factor. This allowance should be checked in the same manner as for meters not so marked and in such a case, the expansion factor should be omitted in computing the calibration readings in X1.7.

Note X4 - It will be sufficiently accurate for this purpose to use an approximate value for P determined by making a preliminary calibration test as described in X1.7 except that an approximate value for the calibration factor, K, should be used. For this test $K = 0.98R$ which is the same as Eq. X2 except that the expansion reading, D, as yet unknown, is assumed to be zero.

X1.5.2 For meters of Type B design, the allowance for the expansion factor, D, is included in the difference between the initial pressure indicated on the pressure gage and the zero percent mark on the air-content scale on the pressure gage. This allowance shall be checked by filling the apparatus with water (making certain that all entrapped air has been removed), pumping air into the air chamber until the gage hand is stabilized at the indicated initial pressure line, and then releasing the air to the measuring bowl. If the initial pressure line is correctly positioned, the gage should read zero percent. The initial pressure line shall be adjusted if two or more determinations show the same variation from zero percent and the test repeated to check the adjusted initial pressure line.

Note X5 - This procedure may be accomplished in conjunction with the calibration test described in X1.9.

X1.6 Calibration Reading, K - The calibration reading, K, is the final meter reading to be obtained when the meter is operated at the correct calibration pressure.

X1.6.1 For meter Types A, the calibration reading, K, is as follows:

$$K = R + D \quad (X3)$$

Where:

R = effective volume of the calibration vessel (X4.1), and
D = expansion factor (X5.1).

X1.6.2 For meter Types B the calibration reading, K, equals the effective volume of the calibration vessel (X4.2) as follows:

$$K = R \quad (X4)$$

Note X6 - If the water column indicator is graduated to include an initial water level and a zero mark, the difference between the two marks being equivalent to the expansion factor, the term D shall be omitted from Eq. X3.

X1.7 Calibration Test to Determine Operating Pressure, P, on Pressure Gage, Type A Meter - If the rim of the calibration cylinder contains no recesses or projections, fit it with three or more spacers equally spaced around the circumference. Invert the cylinder and place it at the center of the dry bottom of the measuring bowl. The spacers will provide an opening for flow of water into the calibration cylinder when pressure is applied. Secure the inverted cylinder against displacement and carefully lower the cover assembly. After the cover is clamped in place, carefully adjust the apparatus assembly to a vertical position and add water at air temperature, by means of the tube and funnel, until it rises above the zero mark on the standpipe. Close the vent and pump air into the apparatus to the approximate operating pressure. Incline the assembly about 30° from vertical and, using the bottom of the bowl as a pivot, describe several complete circles with the upper end of the standpipe, simultaneously tapping the cover and sides of the bowl lightly to remove any entrapped air adhering to the inner surfaces of the apparatus. Return the apparatus to a vertical position, gradually release the pressure (to avoid loss of air from the calibration vessel) and open the vent. Bring the water level exactly to the zero mark by bleeding water through the petcock in the top of the conical cover. After closing the vent, apply pressure until the water level has dropped an amount equivalent to about 0.1 to 0.2% of air more than the value of the calibration reading, K, determined as described in X1.6. To relieve local restraints, lightly tap the sides of the bowl and when the water level is exactly at the value of the calibration reading, K, read the pressure, P, indicated by the gage and record to the nearest 690 Pa (0.1 psi). Gradually release the pressure and open the vent to determine whether the water level returns to the zero mark when the sides of the bowl are tapped lightly (failure to do so indicates loss of air from the calibration vessel or loss of water due to a leak in the assembly). If the water level fails to return to within 0.05% air of the zero mark and no leakage beyond a few drops of water is found, some air probably was lost from the calibration cylinder. In this case, repeat the calibration procedure step by step from the beginning of this paragraph. If the leakage is more than a few drops of water, tighten the leaking joint before repeating the calibration procedure. Check the indicated pressure reading promptly by bringing the water level exactly to the zero mark, closing the vent, and applying pressure, P, just determined. Tap the gage lightly with a finger. When the gage indicates the exact pressure, P, the water column should read the value of the calibration factor, K, used in the first pressure application within about 0.05% of air. Caution - The apparatus assembly must not be moved from the vertical position until pressure has been applied which will force water about one-third of the way up into the calibration cylinder. Any loss of air from this cylinder will nullify the calibration.

X1.8 Calibration Test to Determine Alternative Operating Pressure P1, Meter Type A - The range of air contents which can be measured with a given meter can be doubled by determining an alternative operating pressure P1 such that the meter reads half of the calibration reading, K, (Eq. X3). Exact calibration will require determination of the expansion factor at the reduced pressure in X1.5. For most purposes the change in expansion factor can be disregarded and the alternative operating pressure determined during the determination of the regular operating pressure in X1.7.

X1.9 Calibration Test to Check the Air Content Graduations on the Pressure Gage, Type B Meter - Fill the measuring bowl with water as described in X1.3. Screw the short piece of tubing or pipe furnished with the apparatus into the threaded petcock hole on the underside of the cover assembly. Assemble the apparatus. Close the air valve between the air chamber and the measuring bowl and open the two petcocks on holes through the cover assembly. Add water through the petcock on the cover assembly having the extension below until all air is expelled from the second petcock. Pump air into the air chamber until the pressure reaches the indicated initial pressure line. Allow a few seconds for the compressed air to cool to normal temperature. Stabilize the gage hand at the initial pressure line by pumping or bleeding off air as necessary, tapping the gage lightly. Close the petcock not provided with the tube or pipe extension on the under side of the cover. Remove water from the assembly to the calibrating vessel controlling the flow, depending on the particular meter design, by opening the petcock provided with the tube or pipe extension and cracking the air valve between the air chamber and the measuring bowl, or by opening the air valve and using the petcock to control flow. Perform the calibration at an air content which is within the normal range of use. If the calibration vessel (X1.2) has a capacity within the normal range of use, remove exactly that amount of water. With some meters the calibrating vessel is quite small and it will be necessary to remove several times that volume to obtain an air content within the normal range of use. In this instance, carefully collect the water in an auxiliary container and determine the amount removed by weighing to the nearest 0.1%. Calculate the correct air content, R , by using Eq. X2. Release the air from the apparatus at the petcock not used for filling the calibration vessel and if the apparatus employs an auxiliary tube for filling the calibration container, open the petcock to which the tube is connected to drain the tube back into the measuring bowl. At this point of procedure the measuring bowl contains the percentage of air determined by the calibration test of the calibrating vessel. Pump air into the air chamber until the pressure reaches the initial pressure line marked on the pressure gage, close both petcocks in the cover assembly, and then open the valve between the air chamber and the measuring bowl. The indicated air content on the pressure gage dial should correspond to the percentage of air determined to be in the measuring bowl. If two or more determinations show the same variation from the correct air content, the dial hand shall be reset to the correct air content and the test repeated until the gage reading corresponds to the calibrated air content within 0.1%. If the dial hand was reset to obtain the correct air content, recheck the initial pressure mark as in X1.5.2. If a new initial pressure reading is required, repeat the calibration to check the accuracy of the graduation on the pressure gage described earlier in this section. If difficulty is encountered in obtaining consistent readings, check for leaks, for the presence of water inside the air chamber (see Fig. 2), or the presence of air bubbles clinging to the inside surfaces of the meter from the use of cool aerated water. In this latter instance use deaerated water which can be obtained by cooling hot water to room temperature.

Note X7 - If the calibrating vessel is an integral part of the cover assembly, the petcock used in filling the vessel should be closed immediately after filling the calibration vessel and not opened until the test is complete.

Standard Method of Test for
Quantitative Extraction of Asphalt From
Asphalt Paving Mixtures
WFLHD Designation: T 164-94 (Modified AASHTO T 164)

1. SCOPE

1.1 These methods cover the quantitative determination of asphalt in hot-mixed paving mixtures and pavement samples. Aggregate obtained by these methods may be used for sieve analysis using T 30.

Note 1 - The results obtained by these methods may be affected by the age of the material tested, with older samples tending to yield slightly lower asphalt content. Best quantitative results are obtained when the test is made on mixtures and pavements shortly after their preparation.

2. APPLICABLE DOCUMENTS

2.1 AASHTO Standards:

- T 30 Mechanical Analysis of Extracted Aggregate
- T 44 Solubility of Bituminous Materials in Trichloroethylene
- T 84 Specific Gravity and Absorption of Fine Aggregate
- T 110 Moisture or Volatile Distillates in Bituminous Paving Mixtures
- T 168 Sampling Bituminous Paving Mixtures
- T 170 Recovery of Asphalt from Solution by Abson Method
- T 228 Specific Gravity of Semi-Solid Bituminous Materials
- T 248 Reducing Field Samples of Aggregates to Testing Size

3. SUMMARY OF METHODS

3.1 The paving mixture is extracted with trichloroethylene, 1-1-1-trichloroethane, or methylene chloride, using the extraction equipment applicable to the particular method. The asphalt content is calculated by difference from the mass of the extracted aggregate, moisture content, and mineral matter, in the extract. The asphalt content is expressed as mass percent of moisture-free mixtures.

4. SIGNIFICANCE AND USE

4.1 All of the methods can be used for quantitative determinations of asphalt in hot-mixed paving mixtures and pavement samples for specification acceptance, service evaluation, control, and research. Each method prescribes the solvent or solvents and any other reagents that can be used in the method. AASHTO T 170 requires that Method A or E and reagent grade trichloroethylene be used when asphalt is recovered from solution.

Note 2 - The vacuum extractor, Section 25.1.1 can be modified by a vacuum trap attached to the top of the "end-point" site tube to collect the extract to allow its use for recoveries.

5. APPARATUS

5.1 Oven, capable of maintaining the temperature at 110 ± 5 C (230 ± 9 F).

5.2 Pan, flat, of appropriate size to warm test specimens.

5.3 Balances or scales and weights meeting the requirements of M 231 shall be provided as appropriate for the sample mass.

5.4 Hot plate, electric, with adjustable heating rate (optional).

5.5 Cylinders, graduated, 1000 or 2000 mL capacity. Optional cylinder, 100 mL capacity.

5.6 Ignition dish, 125 mL capacity.

5.7 Desiccator.

6. REAGENT

6.1 The reagent shall be Trichloroethylene, 1-1-1 Trichloroethane, or Methylene Chloride.

7. PRECAUTIONS

7.1 The solvents listed in Section 6 should be used only under a hood or with an effective surface exhaust system in a well ventilated area, since they are all toxic to some degree as indicated below:

Solvent	Time-Weighted Average Concentration for 8 h Exposure for 5 Day Week, ppm
Methylene chloride	200 ^A
Trichloroethylene	100 ^A
1-1-1-Trichloroethane	350 ^A

^A Threshold Limit Concentration Committee of the American Conference of Governmental Hygienists, 1977 Values.

7.2 Trichloroethylene and 1-1-1-Trichloroethane in the presence of heat and moisture may form acids that are extremely corrosive to certain metals, particularly when subject to contact over lengthy periods of time. Proper precautions should be taken to not allow these two solvents to remain in small quantities in the effluent tanks of aluminum vacuum extractors.

7.3 Trichloroethylene when stored in a steel container and in continuous contact with moisture may decompose by dehydrohalogenation to form unsaturated hydrocarbon liquids and hydrogen chloride. Steel drums containing trichloroethylene should be stored in a cool, dry location, kept tightly sealed and opened as infrequently as possible. Trichloroethylene should be transferred from the drums to clean, dry, brown glass bottles for laboratory use. The hydrogen chloride in decomposed trichloroethylene may harden an asphalt during the extraction and Abson recovery test (AASHTO T 170).

7.4 The boiling point of methylene chloride is approximately 104 F. It is therefore recommended that the methylene chloride drums be stored in the shade.

7.5 Consult the OSHA Safety Data Sheet for the reagent being used.

8. SAMPLING

8.1 Obtain samples in accordance with AASHTO T 168.

8.2 Preparation of Test Specimens:

8.2.1 If the mixture is not sufficiently soft to separate with a spatula or trowel, place it in a large, flat pan and warm to 110 ± 5 C (230 ± 9 F) only until it can be handled or mixed. Split or quarter the material until the mass of material in accordance with AASHTO T 248 required for test is obtained.

8.2.2 The size of the test sample shall be governed by the nominal maximum aggregate size in the mixture and conform to the mass requirement shown in Table 1.

Table 1
Size of Sample

Nominal Maximum Aggregate Size		Minimum Mass of Sample
mm	(U.S. Standard)	g
4.75	(No. 4)	500
9.5	(3/8 in.)	1000
12.5	(1/2 in.)	1500
19.0	(3/4 in.)	2500
25.0	(1 in.)	3000
37.5	(1-1/2 in.)	4000

Note 4 - When the mass of the test specimen exceeds the capacity of the equipment used (for a particular method), the test specimen may be divided into suitable increments, tested, and the results appropriately combined for calculation of asphalt content.

8.2.3 In addition, a test specimen is required for the determination of moisture in Section 9. Take this test specimen from the remaining sample of the mixture immediately after obtaining the extraction test specimen.

Note 5 - If recovery of asphalt from the solution obtained from the extraction test is not required, the entire test specimen may be dried to constant mass in a mechanical convection oven (ASTM E 145) at a temperature of 149-163 C (300-325 F) for 2 to 2-1/2 hours prior to extraction instead of determining the moisture content as required in Section 9.

9. MOISTURE CONTENT

9.1 Determine the moisture content of the mixture in accordance with the procedure described in AASHTO T 110.

9.2 Calculate the mass of water in the extraction test portion by multiplying mass percent water by the mass of the extraction test portion.

METHODS A, B, C, & D

Methods A, B, C, & D are not applicable to FLH field testing and have been deliberately omitted.

METHOD E

25. APPARATUS

25.1 In addition to the apparatus listed in Section 5, the following apparatus is required for Method E.

25.1.1 Vacuum Extractor, complete with the vacuum pump, gasket, rubber tubing, filter paper, support plate, and funnel ring, similar to either of those shown in Figure 1 and Figure 2.

25.1.2 Filter Paper, medium-grade, fast-filtering, 330 mm in diameter.

25.1.3 Stainless Steel Beaker, having a capacity of 8.5 L (9 qt.).

25.1.4 Erlenmeyer Flasks, glass two, having a capacity of 4000 mL each.

25.1.5 Graduate, glass, having a capacity of 500 mL.

25.1.6 Wash Bottle, plastic having a capacity of 500 mL.

- 25.1.7 Dial Thermometer, having a range from 10 - 82 C (50 - 180 F).
- 25.1.8 Mixing Spoon, 305 mm (12 in.) long.
- 25.1.9 Spatula, 229 mm (9 in.) long.
- 25.1.10 Stiff Bristled Brush, 25 mm (1 in.) wide.
- 25.1.11 Erlenmeyer Flask, glass, having a capacity of 1000 mL.
- 25.1.12 Watch Glass, having a 102 mm (4 in.) diameter (optional).
- 25.1.13 Metal Tongs, 152 - 203 mm (6 - 8 in.) long.
- 25.1.14 304.8 mm (12 in.) diameter 2.00 mm (No. 10) and 75 μ m (No. 200) sieves.
- 25.1.15 Ultrasonic cleaner with insert tray of approximately 4 Liter (1 gallon) capacity, 150 - 200 watts (optional).

26. REAGENTS AND MATERIALS

- 26.1 Diatomaceous Silica Filtering Aid conforming to Type B of ASTM D 604.⁴
- 26.2 Ethyl Alcohol, denatured (optional).
- 26.3 The solvent shall be as specified in Section 6.

27. PREPARATION OF TEST PORTIONS

- 27.1 Prepare test portions for moisture determination and extraction in accordance with the procedure described in Section 8.

⁴Celite 110, manufactured by Johns-Manville, has been found satisfactory for this purpose; however, all filtering aids should be pre-sieved through a 75 μ m (No. 200) sieve when the gradation test on the aggregate is to be performed.

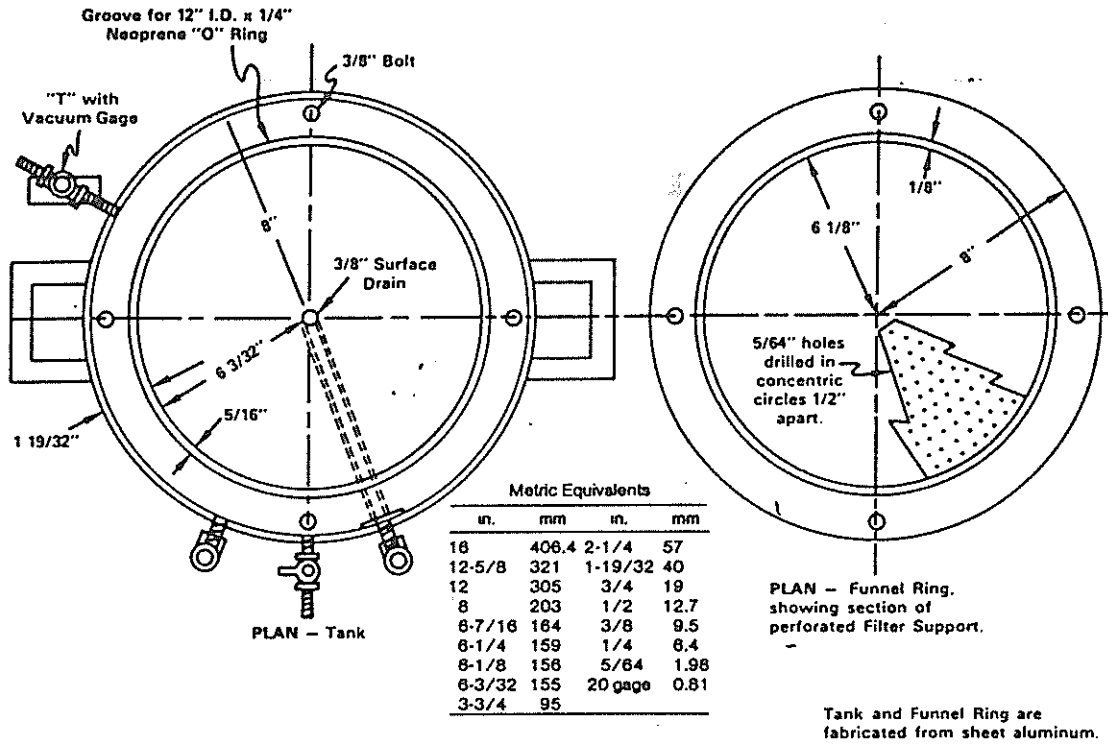
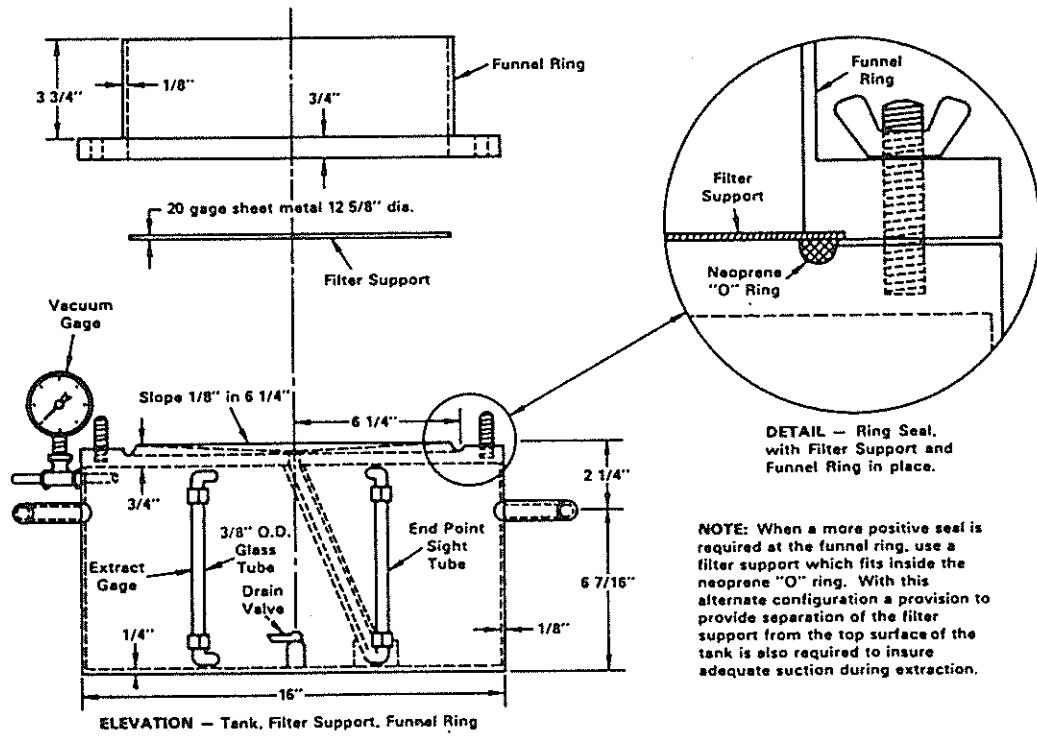
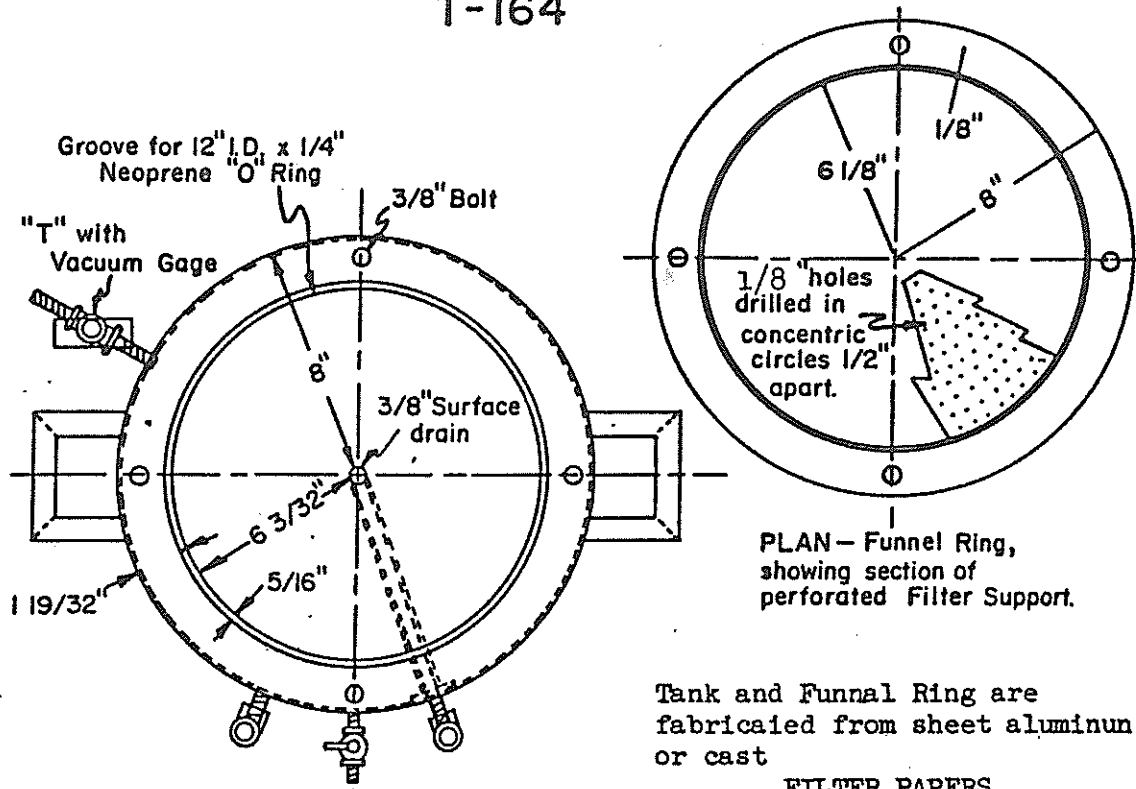

Fig. 6(a). Vacuum Extractor



T-164



Tank and Funnel Ring are fabricated from sheet aluminum or cast

FILTER PAPERS

Eaton Dirkeman	33cm	Grade 615
Whatman	33cm	#4
S & S	33cm	595

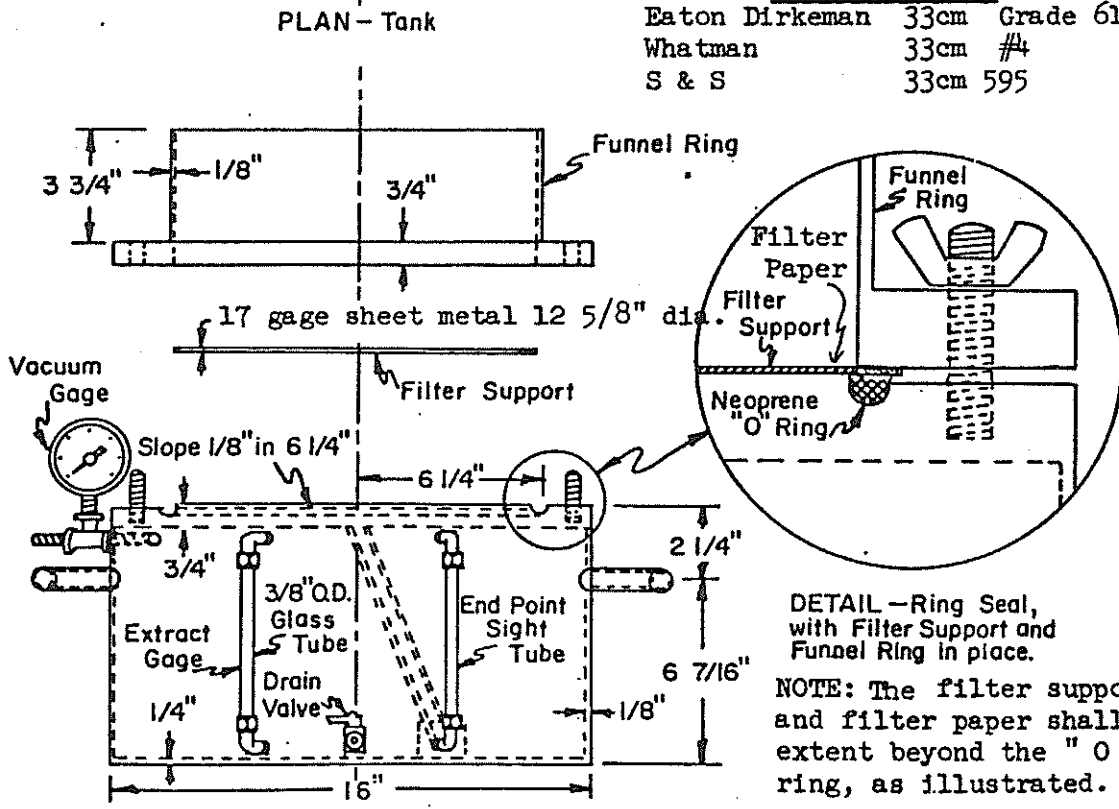

FIGURE - 2, TYPICAL VACUUM EXTRACTOR

28. METHOD E

28.1 If the sample temperature is above 93 C (200 F), cool to a temperature less than 93 C (200 F). The ideal temperature for testing is considered to be approximately 60 C (104 F). When sufficiently cool, carefully pour approximately 200 ml of alcohol over the sample in small amounts to minimize boiling. Add approximately 700 ml of solvent and stir until the asphalt is visually in solution.

Note 13 - The use of alcohol is optional.

28.2 Place a dry, tared filter paper on the vacuum extractor, taking care to center the filter on the funnel ring, and tighten the wing nuts finger tight.

Note 14 - Oven dry filter paper before placing in vacuum extractor.

28.3 Weigh out approximately 200 grams (record exact mass) of oven-dried diatomaceous silica filtering aid [which passes a 75 μm (No. 200) sieve] into a 1000 ml flask. Add approximately 500 ml of solvent and swirl until the filtering aid is completely in suspension. Immediately pour the filtering aid solution onto the filter. Start the vacuum pump and let it run until the pad formed by the filtering aid is surface dry and begins to crack slightly.

28.4 Before decanting the washing solution, place a second piece of filter paper on the filter and start the vacuum pump. Then gently pour the solution from the sample container over a 2.00 mm (No. 10) and 75 μm (No. 200) sieve and onto the second piece of filter paper. Stop the vacuum when all solution has been removed.

28.5 Add approximately another 700 ml of solvent to the sample container and stir. Start the vacuum pump and gently pour the solution over a 2.00 mm (No. 10) and 75 μm (No. 200) sieve and onto the filter into the extractor. Stop the vacuum when all solution has been removed.

28.6 Repeat Section 28.4 until the solution is a light straw color and the aggregate is visually clean. After the last wash, gently pour the entire sample over the 2.00 mm (No. 10) and 75 μm (No. 200) sieves into the extractor and thoroughly rinse all aggregate particles from the sample container and spoon into the extractor.

28.7 Start the vacuum pump and let it run for a few minutes to expedite drying of the aggregate. After stopping the vacuum, scrape the filtering aid away from the side of the funnel ring toward the center of the filter to prevent loss when the ring is removed.

28.8 Remove the funnel ring and brush any clinging filtering aid into the tared drying pan. Carefully pick up the filter blanket and transfer to the drying pan. Carefully transfer the aggregate to a tared drying pan.

28.9 Dry the extracted aggregate and filter to a constant mass at a temperature of 110 ± 5 C (230 ± 9 F) (see AASHTO T 255). When drying, stir the sample occasionally, taking care not to lose any material.

29. CALCULATIONS

29.1 Calculate the percent of asphalt by weight of the total mixture, K, using the work sheet, Form FHWA 1623. Report the asphalt content to the nearest 0.01 percent.

Note 14 - Retention Factor: It must be realized that with some aggregates, asphalt will be absorbed into the aggregate. Rapid extraction of this absorbed asphalt is impractical. Therefore, a retention factor should be determined to correct the asphalt percent obtained. A retention factor can be obtained by extracting a mix where the exact quantities of asphalt and aggregate are known. Asphaltic mixture batches of approximately 2500 grams should be combined and extracted on the project prior to operation of the hot plant. Each operator shall establish a retention factor in accordance with FLH T 519:

30. PRECISION

30.1 The single-laboratory standard deviation has been found to be 0.18 percent. Therefore, results of two properly conducted tests by the same operator on the same batch should not differ by more than 0.52 percent.

30.2 The multi-laboratory standard deviation has been found to be 0.29 percent. Therefore, the results of two properly conducted tests from two different laboratories on samples from the same batch should not differ by more than 0.81 percent.

Note 20 - These numbers represent, respectively, the (1S) and (D2S) limits as described in Recommended Practice ASTM C 670.

Note 21 - These precision statements are based on one pair of reference samples with 59 laboratories participating and 3 laboratory results deleted as outlying observations. The reference samples contained aggregate with 98 percent passing the 9.5 mm (3/8 in.) screen. All methods were used in the inter-laboratory test program.



WORKSHEET FOR DETERMINING GRADATION AND ASPHALT CONTENT OF ASPHALT CONCRETE AASHTO T 30, T 110 AND T 164

Project BANKS-LOWMAN Source 10-08-0003
 Sample of 40101 Lot No. 1 Sample No. 7
 Where sampled 3' LT @ STA 129+08 Time sample was taken 2:35 PM
 Sampled by J.P. HORN Date 7-11-93 Tested by J.P. HORN Date 7-11-93

VACUM EXTRACTION (AASHTO T-164)

A. Wt of extracted aggregate + filter blanket ¹ <u>2227.5 + 349.0 = 2576.5</u>	G. Wt of bitumen [E-F] <u>147.94</u>
B. Wt of filter paper + diatomaceous silica aid <u>26.2 + 199.1 = 225.3</u>	H. % Bitumen by wt of aggregate [100(G + C)] <u>6.29</u>
C. Wt of extracted aggregate [A-B] <u>2351.2</u>	I. Retention factor ² <u>0.31</u>
D. Wt of sample before extraction <u>2504.4</u>	J. Adjusted % bitumen by wt of aggregate [H + I] <u>6.60</u>
E. Wt of bitumen and moisture [D-C] <u>153.20</u>	K. % Bitumen by wt of mix 100[J + (100 + J)] <u>6.19</u>
F. Wt of moisture [(D)(O) + 100] <u>5.26</u>	

SIEVE ANALYSIS (AASHTO T-30)

Sieve Size	Wt. ¹ Retained	% Retained	% Passing	Target Values	Allowable Deviations
3/4"	0	0	100	100.0	
1/2"	67.7	2.9	97.1	95.5	±5
3/8"	274.1	11.6	85.5	84.0	±6
#4	629.0	26.8	58.7	56.3	±7
#8	465.8	19.8	38.9	37.2	±5
#40	509.2	21.7	17.2	17.0	±3
#200	256.5	10.9	6.3	6.0	±2
Pan	26.1				
Fines in Filter	123.7				
Total ³	2352.1				
Extracted Wt. (C)	2351.2				

MOISTURE CONTENT (AASHTO T 110)

L. Weight of sample 513.0
 M. Volume of solvent (mL) 200
 N. Volume of water (mL) 1.1
 O. Moisture content (%) [100N + L] 0.21

¹ All weights are in grams.

² Individual tester retention factor.

³ Total weight should be within 0.2% of the weight of extracted aggregate (C).

REMARKS: _____

Standard Method of Test for

Bulk Specific Gravity of Compacted Asphalt Mixtures Using Saturated Surface-Dry Specimens WFLHD Designation: T 166-94 (Modified AASHTO T 166)

1. SCOPE

1.1 This method of test covers the determination of bulk specific gravity of specimens of compacted asphalt mixtures as defined in AASHTO M 132, Terms Relating to Density and Specific Gravity of Solids, Liquids, and Gases.

1.2 This method should not be used with samples that contain open or interconnecting voids and absorb more than 6 percent of water by volume, as determined by this procedure.

1.3 The bulk specific gravity of the compacted asphalt mixtures may be used in calculating the unit weight of the mixture.

2. TEST SPECIMENS

2.1 Text specimens may be either laboratory-molded asphalt mixtures or from asphaltic pavements. The mixtures may be surface or wearing course, binder or leveling course, or hot-mix base.

2.2 Size of Specimens - It is recommended, (1) that the diameter of cylindrically molded or cored specimens, or the length of the sides of sawed specimens, be at least equal to four times the maximum size of the aggregate; and (2) that the thickness of specimens be at least one and one half times the maximum size of the aggregate.

2.3 Pavement specimens shall be taken from pavements with core drill, diamond or carborundum saw, or by other suitable means.

2.4 Care shall be taken to avoid distortion, bending, or cracking of specimens during and after the removal from pavement or mold. Specimens shall be stored in a safe, cool place.

2.5 Specimens shall be free from foreign materials such as seal coat, tack coat, foundation material, soil, paper, or foil.

2.6 If desired, specimens may be separated from other pavement layers by sawing or other suitable means.

METHOD A

3. APPARATUS

3.1 Balance - Conforming to the requirements of M 231, for the class of balance required for the principal sample weight of the sample being tested. The balance shall be equipped with suitable suspension apparatus and holder to permit weighing the specimen while suspended from the center of scale pan of balance, see Figure 1.

Note 1 - The holder should be immersed to a depth sufficient to cover it and the test sample during weighing. Wire suspending the holder should be the smallest practical size to minimize any possible effects of a variable immersed length.

3.2 Water Bath - For immersing the specimen in water while suspended under the balance, equipped with an overflow outlet for maintaining a constant water level.

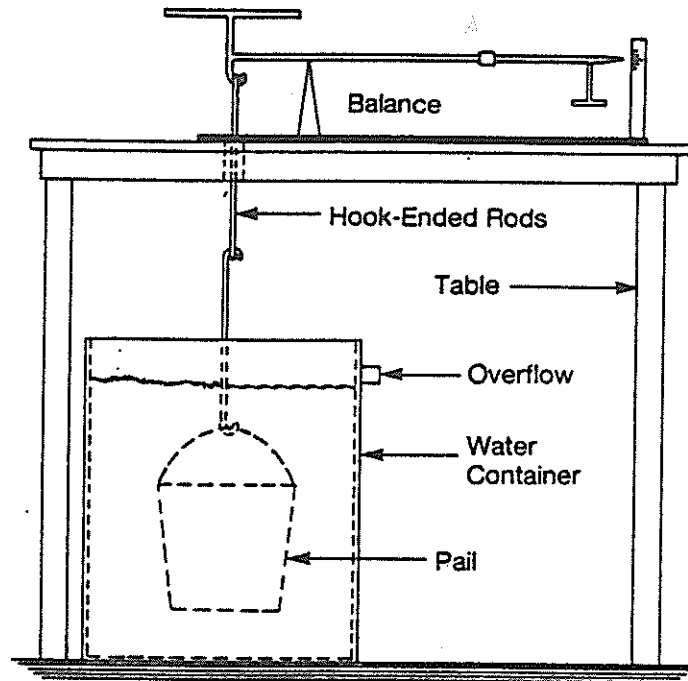

Typical Set Up
Figure 1

4. PROCEDURE

4.1 Dry the specimen to a constant mass. Cool the specimen to room temperature at 25 ± 1 C (77 ± 2 F), and record the dry mass (A). Immerse each specimen in water at 25 ± 1 C (77 ± 2 F) for 3 to 5 minutes and record the immersed mass (C). Remove the specimen from the water, quickly surface dry by blotting with a damp towel, and determine the surface-dry mass (B). The elapsed time from when the specimen is removed from the water until it is placed on the balance shall be 3 ± 1 second. Any water that seeps from the specimen during the weighing operation is considered part of the saturated specimen.

Note 2 - Constant mass shall be defined as the mass at which further drying at 52 ± 3 C (125 ± 5 F) does not alter the mass 0.05 percent. Samples shall initially be dried overnight (minimum of 12 hours) at 52 ± 3 C (125 ± 5 F) and then weighed at two hour drying intervals. Recently molded laboratory samples which have not been exposed to moisture do not require drying.

Note 3 - The sequence of testing operations may not be changed.

5. CALCULATION

5.1 Calculate the bulk specific gravity of the specimen as follows (report the value to three decimal places):

$$\text{Bulk Specific Gravity} = \frac{A}{B - C}$$

Where: A = mass in grams of dried sample in air,
B = mass in grams of surface-dry specimen in air,
C = mass in grams of sample in water.

5.2 Calculate the percent water absorbed by the specimen (on volume basis) as follows:

$$\text{Percent Water Absorbed by Volume} = \frac{B - A}{B - C} \times 100$$

5.3 If the percent water absorbed by the specimen in Section 5.2 exceeds 6 percent, use AASHTO T 275 (Bulk Specific Gravity of Compacted Bituminous Mixtures Using Paraffin-Coated Specimens).

METHOD B, C & D

Methods B, C & D are not applicable to FLH field testing and have been deliberately omitted.

(INTENTIONALLY LEFT BLANK)

Standard Methods of
Sampling Asphalt Paving Mixtures
WFLHD Designation: T 168-94 (Modified AASHTO T 168)

1. SCOPE

1.1 These methods cover the procedures for sampling mixtures of asphalt materials with mineral aggregate as prepared for use in paving. The samples may be used for any of the following purposes:

1.1.1 To represent an average of the asphalt mixture,

1.1.2 To ascertain the periodic variation in characteristics of the mixture for the purpose of controlling uniformity, or

1.1.3 To determine compliance with the specifications.

2. SELECTION OF SAMPLES

2.1 Sampling is equally as important as the testing, and the sampler shall use every precaution to obtain samples that are truly representative of the asphalt mixture.

2.2 Care shall be taken in sampling to avoid segregation of coarse aggregate and asphalt mortar. Care shall be taken also to prevent contamination by dust or other foreign matter.

2.3 Samples of asphalt mixtures upon which acceptance or rejection of the lot is to be based shall be selected by the purchaser or his authorized representative in accordance with the applicable procedure outlined herein. Samples for preliminary approval may be submitted by the contractor when required.

3. SIZE OF SAMPLE

3.1 The size of sample shall be governed by the maximum size of particle of mineral aggregate in the mixture. The minimum size of sample shall conform to the requirements shown in Table 1.

TABLE 1
SIZE OF SAMPLE

Nominal Maximum Size of Particles Passing Sieve	Minimum Mass of Uncompacted Mixture		Minimum Area of Compacted Mixture	
	kg	(lb)	m ²	(sq in)
2.36 (No. 8)	1.8	(4)	0.023	36
4.75 (No. 4)	1.8	(4)	0.023	36
9.5 (3/8 in)	3.6	(8)	0.023	36
12.5 (1/2 in)	5.4	(12)	0.041	64
19.0 (3/4 in)	7.3	(16)	0.065	100
25.0 (1 in)	9.1	(20)	0.093	144
37.5 (1-1/2 in)	11.3	(25)	0.093	144
50 (2 in)	15.9	(35)	0.145	225

4. SAMPLING PLANT-MIXED ASPHALT MIXTURES AT PLACE OF MANUFACTURE

4.1 A batch freshly discharged from the mixing plant shall be sampled from the pile by means of a scoop or shovel. A sample of the mix should be obtained from the center of the pile after it has been struck-off and leveled to provide a flat area of approximately 1 m² (9 sq. ft.) or more. Equal portions should be obtained at three or more points within the leveled area by pushing a scoop or shovel downward into the material. The entire sample shall be reduced to the required size by mixing and quartering on a clean, smooth surface. If necessary, the mixture may be warmed to facilitate remixing, but care shall be taken to avoid overheating any part of the sample and only sufficient heat shall be used to permit satisfactory mixing. If samples are taken for the purpose of determining uniformity or compliance with the specifications of the product of the plant, they shall not be mixed but shall be handled separately.

4.2 Samples from a stockpile shall be obtained by compositing equal quantities of the mixture taken from holes dug into points near the top, middle, and bottom of the stockpile. Reduction of the sample to the required size shall be as described in 4.1.

4.3 Samples from a hauling vehicle shall be as described in 4.1.

4.4 Samples from a Conveyor Belt - Stop the conveyor belt while the increments are being obtained. Insert two templates, the shape of which conforms to the shape of the belt, across the asphalt mixture or mark two transverse lines on the belt. Space the templates or transverse lines so that the material contained between them will yield an increment of the required weight. Carefully remove all material between the templates or transverse lines and place in a suitable container.

Note 1 - A convenient sampling device for asphalt mixtures may be made by bending the sides of a round-point shovel to form a tubular scoop approximately 90 mm (3-1/2 in.) in diameter.

5. SAMPLING PLANT-MIXED ASPHALT MIXTURES FROM ROADWAY

5.1 Samples of asphalt paving mixtures taken from the finished pavement for determination of characteristics of the mix shall not be less than the area of pavement surface shown in Table 1 and shall extend the full depth of the course of asphalt mixture being placed. The sample shall be cut in such a manner as to cause a minimum disturbance of the density of the sample and shall be transported firmly wrapped and supported to preserve its shape for the density determination if it is to be made.

5.2 Samples of asphalt paving mixtures taken from the roadway prior to compaction by rollers shall not be less than the mass of uncompacted mix shown in Table 1 and shall extend the full depth of the course of asphalt mixture being placed. The samples shall be obtained by either of the following methods:

5.2.1 A flat sheet of metal of appropriate size shall be placed on the roadway ahead of the paver and its position carefully noted. After the paver passes, the edges of the metal sheet shall be located, and the asphaltic mixture retained thereon shall be carefully removed using a scoop or shovel. After obtaining the sample, the metal sheet shall be removed and the resulting void in the mat filled with fresh mix and raked prior to rolling. The entire sample shall be reduced to the required size by mixing and quartering on a clean, smooth surface.

Note 2 - When the paver passes over the metal sheet it may cause the sheet to slide forward making it difficult to locate. This problem can be eliminated by driving a nail through the corner of the metal sheet and into the roadway. The metal sheet should be oriented so the nailed corner is closest to the paver as it approaches the metal sheet.

5.2.2 Using a scoop or shovel obtain a sample of mix immediately behind the paver, taking care to obtain only asphaltic mix and avoiding contamination by picking up aggregate base material. Care shall also be taken to avoid loss of fines. After obtaining the sample the void in the mat shall be filled with fresh mix and raked prior to rolling. The entire sample shall be reduced to the required size by mixing and quartering on a clean, smooth surface. This method should not be used when the nominal mat thickness is less than 1 inch, when a loss of fines is apparent, or when the sample is being contaminated by the underlying material.

6. SAMPLING ROAD-MIXED ASPHALTIC MIXTURES

6.1 Samples shall be taken from mixed-in-place asphaltic mixtures for the purpose of determining the physical properties of the mixture and the asphalt content of the mass as well as the uniformity of asphalt content, after the asphalt has been thoroughly incorporated.

6.2 If the mixture is in windrows, a representative sample of the windrow at intervals as specified in the Special Contract Requirements shall be secured and tested separately. Samples of the windrow shall be secured by flattening it at one point into a layer approximately 0.3 m (1 ft.) thick and coring the layer or by pushing a scoop or shovel downward into the layer at three or more equally distributed points to obtain the required size of sample as shown in Table 1.

6.3 If the mix has been bladed into a relatively uniform layer, samples shall be secured at intervals as specified in the Special Contract Requirements and if any further indication of the uniformity of the mixture is required, additional samples shall be obtained. Care shall be exercised to avoid including material from the subgrade or base on which the pavement is being constructed.

6.4 Samples from the completed pavement shall be taken in the same manner and at the same frequency as directed for plant-mixed pavement in Section 5.

7. IDENTIFICATION AND SHIPPING OF SAMPLES

7.1 Transport samples in containers so constructed as to preclude loss or contamination of any part of the sample, or damage to the contents from mishandling during shipment.

7.2 Samples shall have individual identification attached giving the information required by the sample user. Typical information that may be useful could include, but not necessarily be limited to the following:

7.2.1 Job for which the material is to be used, giving project number, highway route number, county, and other pertinent geographical information.

7.2.2 Source of sample, including for plant-mixed samples the name of owner or operator of plant, location of plant, type of plant, size of batch, and identification of asphalt and mineral aggregates used in the mixture.

7.2.3 Point at which sampled, for samples taken from roadway, both by station number and location transversely in pavement; also whether sampled from completed pavement, windrow, etc,

7.2.4 Quantity represented,

7.2.5 By whom sampled and title,

7.2.6 Date of most recent mixing, if road mixed,

7.2.7 Date sampled,

7.2.8 By whom submitted and address,

7.2.9 Purpose for which sample was taken, and

7.2.10 To whom report is to be made.

Standard Method of Test for

Plastic Fines in Graded Aggregates and Soils by Use of the Sand Equivalent Test WFLHD Designation: T 176-94 (Modified AASHTO T 176)

1. SCOPE

1.1 This test is intended to serve as a rapid field test to show the relative proportions of fine dust or claylike material in soils or graded aggregates.

2. APPARATUS

2.1 A graduated plastic cylinder, rubber stopper, irrigator tube, weighted foot assembly, and siphon assembly, all conforming to their respective specifications and dimensions shown in Fig. 1. Fit the siphon assembly to a 4 liter (1 gallon) bottle of working calcium chloride solution (see 2.8) placed on a shelf 915 ± 25 mm (36 ± 1 in.) above the work surface. In lieu of the specified 4 liter (1 gallon) bottle, a glass or plastic vat having a larger capacity may be used providing the liquid level of the working solution is maintained between 915 to 1170 mm (36 and 46 inches) above the work surface. (See Fig. 2.)

Note 1 - An older model of weighted foot assembly has a guide cap that fits over the upper end of the graduated cylinder and centers the rod in the cylinder, and the foot of the assembly has a conical upper surface and three centering screws to center it loosely in the cylinder. The older model does not have the sand reading indicator affixed to the rod (Fig. 1), but a slot in the centering screws of the weighted foot is used to indicate the sand reading. Apparatus with the sand reading indicator (Fig. 1) is preferred for testing clayey materials.

2.2 A 85 ml (3 oz.) tinned box approximately 57 mm (2-1/4 in.) in diameter, with Gill style cover and having a capacity of 85 ± 5 ml.

2.3 A wide-mouth funnel approximately 100 mm (4 in.) in diameter at the mouth.

2.4 A clock or watch reading in minutes and seconds.

2.5 A mechanical shaker as shown in Fig. 3, having a throw of 203.2 ± 1.02 mm (8 ± 0.04 in.), and operating at 2.92 ± 0.03 Hz (175 ± 2 cycles per minute). Prior to use, fasten the mechanical sand equivalent shaker securely to a firm and level mount.

2.6 A manually operated shaker as shown in Fig. 4, capable of producing an oscillating motion at the rate of 100 complete cycles in 45 ± 5 s, with a hand-assisted half stroke length of 127.00 ± 5.08 mm (5.0 ± 0.2 in.). The shaker shall be fastened securely to a firm and level mount by bolts or clamps if a large number of determinations are to be made.

Note 2 - The mechanical shaker shall be used when performing referee sand equivalent determinations. Either the mechanical or manually operated shaker should be used in lieu of the hand method whenever possible.

2.7 Stock calcium chloride solution: Prepare the stock calcium chloride solution with the following:

454 g (1 lb.) technical grade anhydrous calcium chloride
2,050 g (1,640 ml) USP glycerine
47 g (45 ml) formaldehyde
(40 percent by volume solution)

2.7.1 Dissolve the calcium chloride in 1.89 liters (1/2 gal.) of distilled or demineralized water. Cool the solution, then filter it through Whatman No. 12 or equivalent filter paper. Add the glycerine and formaldehyde to the filtered solution, mix well, and dilute to 3.79 liters (1 gal.) with distilled or demineralized water.

2.8 Working calcium chloride solution: Prepare the working calcium chloride by diluting one measuring tin full (85 ± 5 ml) of the stock calcium chloride solution to 3.79 liters (1 gal.) with water. Use distilled or demineralized water for the normal preparation of the working solution. However, if it is determined that the local tap water is of such purity that it does not affect the test results, it is permissible to use in lieu of distilled or demineralized water except in the event of dispute.

2.9 A straightedge or spatula, suitable for striking off the excess soil from the tin measure.

2.10 A thermostatically controlled drying oven capable of maintaining a temperature of 110 ± 5 C (230 ± 9 F).

3. CONTROL

3.1 The temperature of the working solution should be maintained at (22 ± 3 C) (72 ± 5 F) during the performance of this test. If field conditions preclude the maintenance of the temperature range, frequent referee samples should be submitted to a laboratory where proper temperature control is possible. It is also possible to establish temperature correction curves for each material being tested where proper temperature control is not possible. However, no general correction curve should be utilized for several materials even within a narrow range of sand equivalent values. Samples which meet the minimums and equivalent requirement at a working solution temperature below the recommended range need not be subject to referee testing.

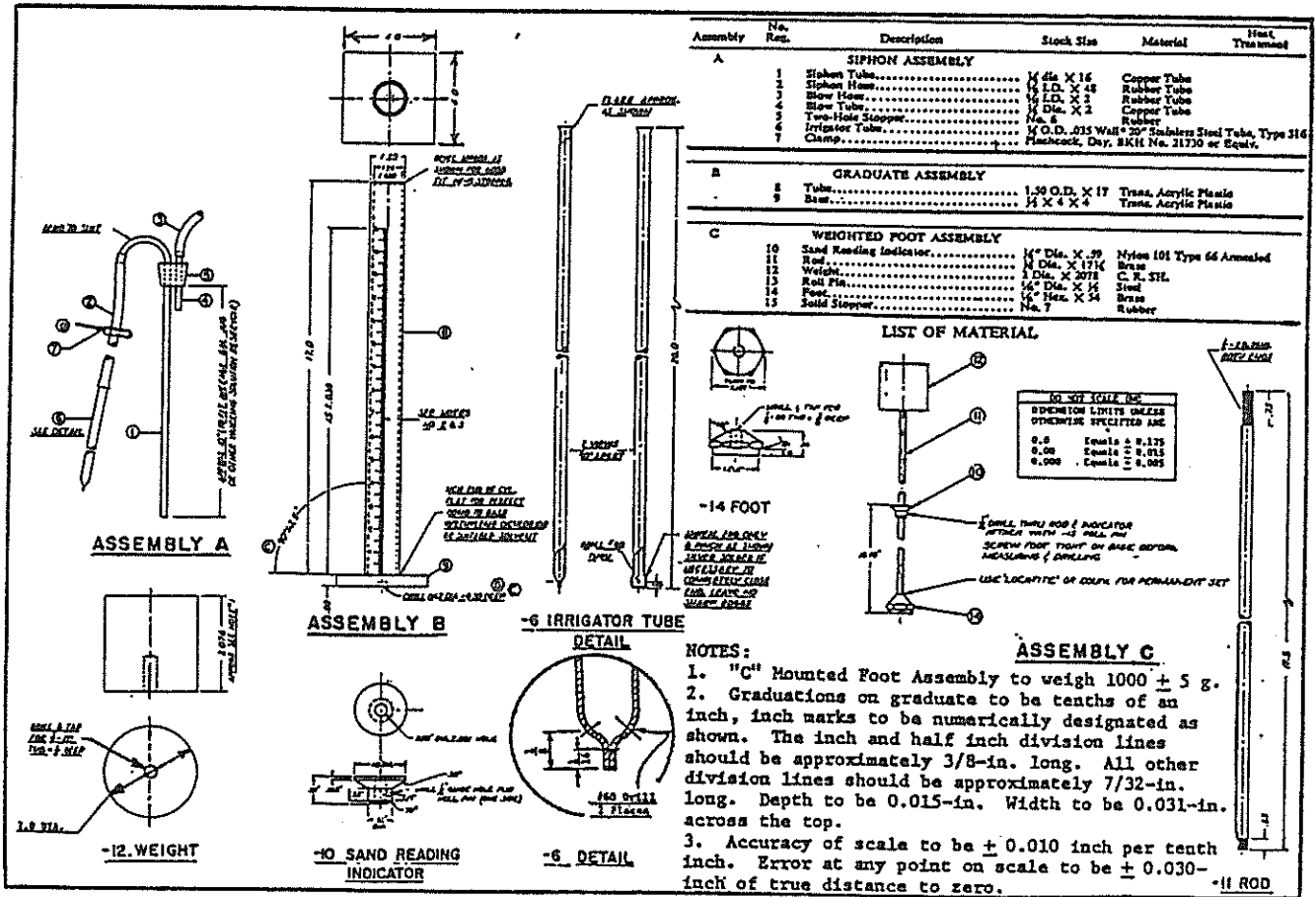

Fig. 1. Sand Equivalent Test Apparatus

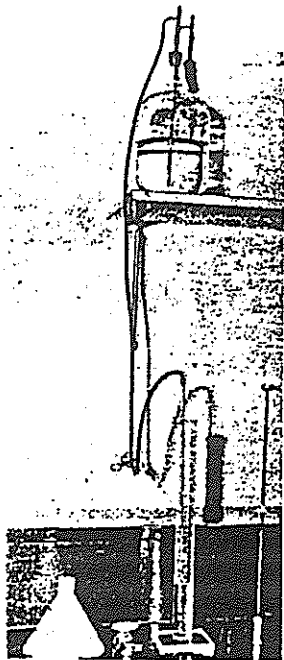

FIG. 2.—*Graduated Cylinder, Irrigator Tube, Weighted Foot Assembly and Siphon.*

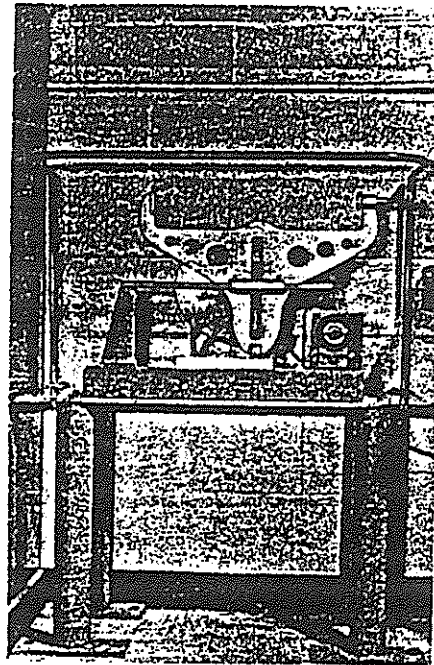

FIG. 3.—*Mechanized Shaker.*

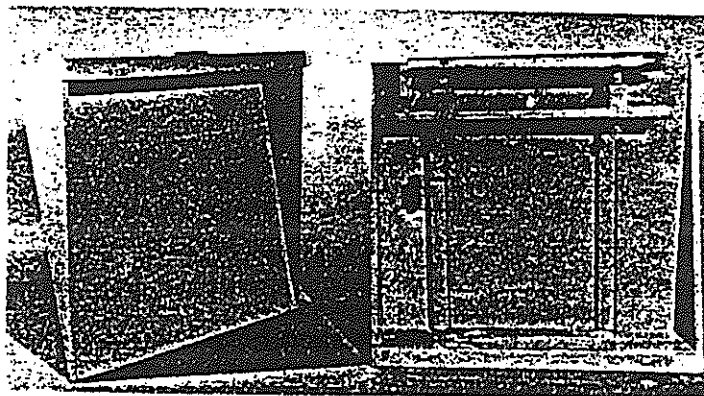

FIG. 4.—*Manually Operated Shaker.*

4. SAMPLE PREPARATION

4.1 The sand equivalent test shall be performed on soils or graded aggregate materials passing the 4.75 mm (No. 4) sieve. All aggregations of fine-grained soil material shall be pulverized to pass the 4.75 mm sieve, and all fines shall be cleaned from the particles retained on the 4.75 mm sieve and included with the material passing the 4.75 mm sieve.

4.2 Split or quarter enough of the original sample to yield slightly more than four 85 ml (3 oz.) tin measures of material passing the 4.75 mm sieve. Use extreme care to obtain a truly representative portion of the original sample.

Note 3 - Experiments show that as the amount of material being reduced by splitting or quartering is decreased, the accuracy of providing representative portions is reduced. It is imperative that the sample be split or quartered carefully. When it appears necessary, dampen the material before splitting or quartering, to avoid segregation or loss of fines.

4.3 Prepare the desired number of test samples by one of the following methods:

4.3.1 Alternate Method No. 1 - Air Dry.

4.3.1.1 Split or quarter enough material from the passing 4.75 mm sieve to fill the 85 ml (3 oz.) tin measure so it is slightly rounded above the brim. While filling the measure, tap the bottom edge of the tin on the work table or other hard surface to cause consolidation of the material and allow the maximum amount to be placed in the tin. Strike off the tin measure level full with a spatula or straightedge.

4.3.2 Alternate Method No. 2 - Pre-Wet.

4.3.2.1 The sample must be in the proper moisture condition to achieve reliable results. This condition is determined by tightly squeezing a small portion of the thoroughly mixed sample in the palm of the hand. If the cast that is formed permits careful handling without breaking, the correct moisture range has been obtained. If the material is too dry, the cast will crumble and it will be necessary to add water and remix and retest until the material forms a cast. If the material shows any free water it is too wet to test and must be drained and air dried, mixing it frequently to insure uniformity. This overly wet material will form a good cast when checked initially, so the drying process should continue until a squeeze check on the drying material gives a cast which is more fragile and delicate to handle than the original. If the moisture content of the original sample prepared in 4.2 is within the limits described above, the test sample may be obtained immediately. If the moisture content is altered to meet these limits, the altered sample should be placed in a pan, covered with a lid or with a damp cloth which does not touch the material, and allowed to stand for a minimum of 15 minutes.

4.3.2.2 After the minimum 15 minute tempering period, place the sample on the splitting cloth and mix by alternately lifting each corner of the cloth and pulling it over the sample toward the diagonally opposite corner, causing the material to be rolled. When the material appears homogeneous, finish the mixing with the sample in a pile near the center of the cloth.

4.3.2.3 Fill three 85 ml (3 oz.) tin measures by pushing each tin through the base of the pile while exerting pressure with the hand against the pile on the side opposite the measure. As each tin is moved through the pile, hold enough pressure with the hand to cause the material to fill the tin to overflowing. Press firmly with the palm of the hand, compacting the material and allowing the maximum amount to be placed in the tin. Strike off the tin measure level full with a spatula or straightedge.

4.3.3 Referee Method (Mechanical Shaker) - Obtain three 85 ml (3 oz.) tin measures of material by one of the alternate methods, 4.3.1 or 4.3.2, above, then dry each test sample to constant mass at 110 ± 5 C (230 ± 9 F), and cool to room temperature before testing.

Note 4 - Moist test specimens produce lower sand equivalent values than the corresponding oven-dry specimens with almost no exceptions, therefore, if a dual specification encompassing both the wet and dry methods of sample preparation is utilized or when the referee method is used, it will be necessary to determine the appropriate correction for each material since a standard correction does not appear possible. Either method can be employed with equal confidence, however.

Note 5 - Three tests shall be performed on a given sample and the single test values averaged in accordance with 6.3 and 6.3.1.

5. PROCEDURE

5.1 Siphon 101.6 ± 2.5 ml (4 ± 0.1 in.) of working calcium chloride solution into the plastic cylinder. Pour the prepared test sample from the measuring tin into the plastic cylinder using the funnel to avoid spillage. (See Fig. 5.) Tap the bottom of the cylinder sharply on the heel of the hand several times to release air bubbles and to promote thorough wetting of the sample.

5.2 Allow the wetted sample to stand undisturbed for 10 ± 1 minutes. At the end of the 10 minute soaking period, stopper the cylinder, then loosen the material from the bottom by partially inverting the cylinder and shaking it simultaneously.

5.3 After loosening the material from the bottom of the cylinder, shake the cylinder and contents by any one of the following methods:

5.3.1 Mechanical Shaker Method (Referee Method) - Place the stoppered cylinder in the mechanical sand equivalent shaker, set the time, and allow the machine to shake the cylinder and contents for 45 ± 1 seconds.

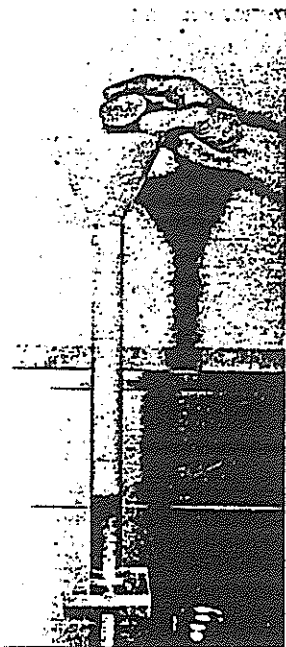

FIG. 5.—Transfer of Sample from Measuring Tin to Cylinder.

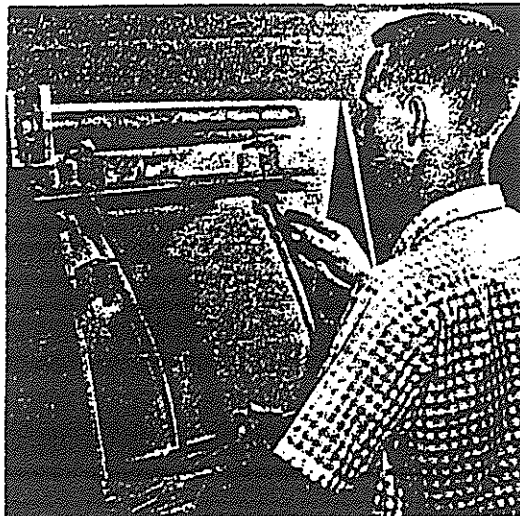

FIG. 6.—Use of Manual Shaker.

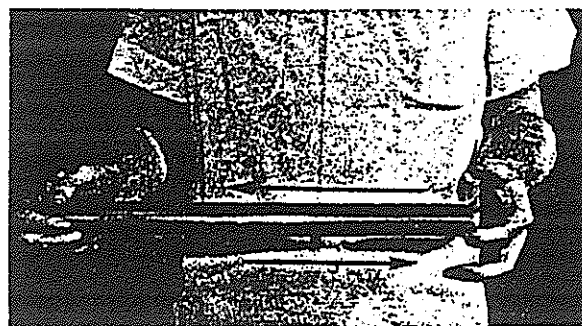

FIG. 7.—Using Hand Method of Shaking.

5.3.2 Manual Shaker Method - Secure the stoppered cylinder in the three spring clamps on the carriage of the hand operated sand equivalent shaker and reset the stroke counter to zero. Stand directly in front of the shaker and force the pointer to the stroke limit marker painted on the backboard by applying an abrupt horizontal thrust to the upper portion of the right hand spring steel strap. Then remove the hand from the strap and allow the spring action of the straps to move the carriage and cylinder in the opposite direction without assistance or hindrance. Apply enough force to the right hand spring steel strap during the thrust portion of each stroke to move the pointer to the stroke limit marker by pushing against the strap with the ends of the fingers to maintain a smooth oscillating motion. (See Fig. 6.) The center of the stroke limit marker is positioned to provide the proper stroke length and its width provides the maximum allowable limits of variation. The proper shaking action is accomplished only when the tip of the pointer reverses direction within the marker limits. Proper shaking action can best be maintained by using only the forearm and wrist action to propel the shaker. Continue the shaking action for 100 strokes.

5.3.3 Hand Method - Hold the cylinder in a horizontal position as illustrated in Fig. 7 and shake it vigorously in a horizontal linear motion from end to end. Shake the cylinder 90 cycles in approximately 30 seconds using a throw of 229 ± 25 mm (9 ± 1 in.). A cycle is defined as a complete back and forth motion. To properly shake the cylinder at this speed, it will be necessary for the operator to shake with the forearms only, relaxing the body and shoulders.

5.4 Following the shaking operation, set the cylinder upright on the work table and remove the stopper.

5.5 Irrigation Procedure - Insert the irrigator tube in the cylinder and rinse material from the cylinder walls as the irrigator is lowered. Force the irrigator through the material to the bottom of the cylinder by applying a gentle stabbing and twisting action while the working solution flows from the irrigator tip. This flushes the fine material into suspension above the coarser sand particles. (See Fig. 8.) Continue to apply the stabbing and twisting action while flushing the fines upward until the cylinder is filled to the 381 mm (15 in.) mark. Then raise the irrigator slowly without shutting off the flow so that the liquid level is maintained at about 381 mm (15 in.) while the irrigator is being withdrawn. Regulate the flow just before the irrigator is entirely withdrawn and adjust the final level to 381 mm (15 in.).

5.6 Allow the cylinder and contents to stand undisturbed for 20 minutes ± 15 seconds. Start the timing immediately after withdrawing the irrigator tube.

5.7 At the end of the 20 minute sedimentation period, read and record the level of the top of the clay suspension. This is referred to as the "clay reading." If no clear line of demarcation has formed at the end of the specified 20 minute sedimentation period, allow the sample to stand undisturbed until a clay reading can be obtained, then immediately read and record the level of the top of the clay suspension and the total sedimentation time. If the total sedimentation time exceeds 30 minutes, rerun the test using three individual samples of the same material. Read and record the clay column height of that sample requiring the shortest sedimentation period only.

5.8 After the clay reading has been taken, the "sand reading" shall be obtained by one of the following methods:

5.8.1 When using the weighted foot assembly having the sand indicator on the rod of the assembly, place the assembly over the cylinder and gently lower the assembly toward the sand. Do not allow the indicator to hit the mouth of the cylinder as the assembly is being lowered. As the weighted foot comes to rest on the sand, tip the assembly toward the graduations on the cylinder until the indicator touches the inside of the cylinder. Subtract 254 mm (10 inches) from the level indicated by the extreme top edge of the indicator and record this value as the "sand reading." (See Fig. 9.)

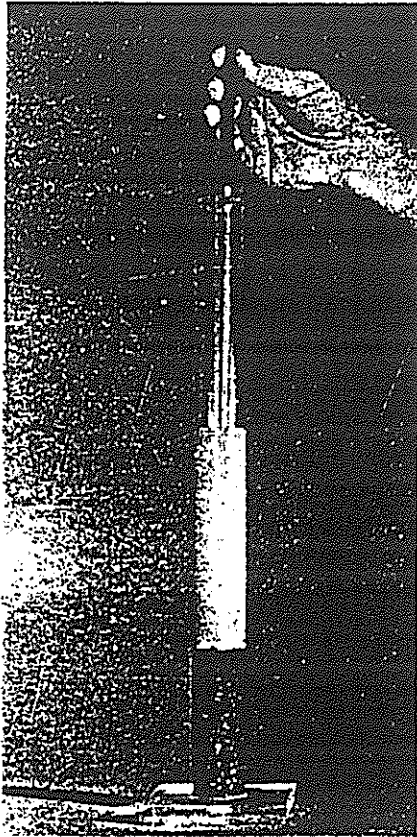

FIG. 8.—Irrigation.

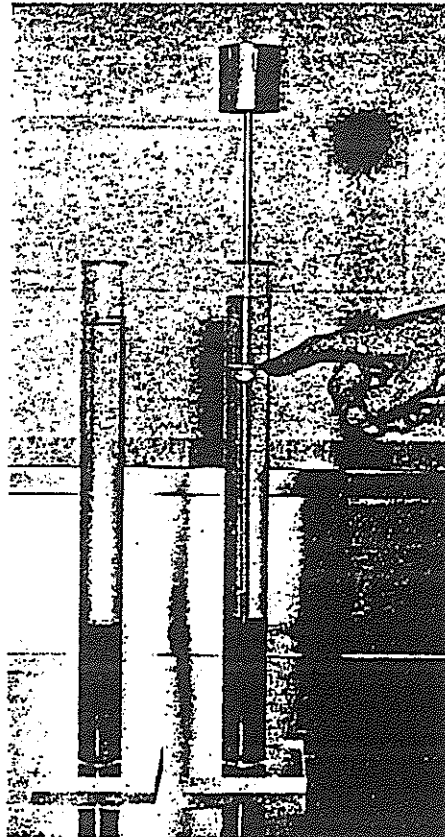

FIG. 9.—Sand Reading.

5.8.2 If an older model weighted foot assembly having centering screws is used, keep one of the centering screws in contact with the cylinder wall near the graduations so that it can be seen at all times while the assembly is being lowered. When the weighted foot has come to rest on the sand, read the level of the centering screw and record this value as the "sand reading."

5.9 If clay or sand readings fall between 2.5 mm (0.1 in.) graduations, record the level of the higher graduation as the reading. For example, a clay reading of 7.95 would be recorded as 8.0, and a sand reading of 3.22 would be recorded as 3.3.

6. CALCULATIONS

6.1 Calculate the sand equivalent (SE) to the nearest 0.1 using the following formula:

$$SE = \frac{\text{Sand Reading} \times 100}{\text{Clay Reading}}$$

6.2 If the calculated sand equivalent is not a whole number, report it as the next higher whole number, as in the following example:

$$SE = \frac{3.3}{8} \times 100 = 41.25, \text{ which is reported as } 42$$

6.3 If it is desired to average a series of sand equivalent values, average the whole number values determined as described above. If the average of these values is not a whole number, raise it to the next higher whole number, as shown in the following example:

Calculated SE values: 41.2, 43.8, 40.9

After raising each to the next higher whole number they become: 42, 44, 41

The average of these values is then determined:

$$\frac{42 + 44 + 41}{3} = 42.3$$

6.3.1 Since the average value is not a whole number, it is raised to the next higher whole number and the reported averages and equivalent value is reported as "43."

7. PRECAUTIONS

7.1 Perform the test in a location free of vibrations; vibrations may cause the suspended material to settle at a rate greater than normal.

7.2 Do not expose the plastic cylinders to direct sunlight any more than is necessary.

7.3 **Removal of Organic Growth:** Occasionally it may be necessary to remove an organic growth from the working calcium chloride solution container and from the inside of the flexible tubing and irrigator tube. This organic material can easily be seen as a slimy substance in the solution. To remove this growth, prepare a cleaning solvent by diluting sodium hypochlorite¹ with an equal quantity of water. Fill the solution container with the prepared cleaning solvent, allow about a liter of the cleaning solvent to flow through the siphon assembly and irrigator tube, then place the pinch clamp on the end of the tubing to cut off the flow of solvent and to hold the solvent in the tube. Refill the container and allow to stand overnight. After soaking, allow the cleaning solvent to flow out through the siphon assembly and irrigator tube. Remove the siphon assembly from the solution container and rinse both with clear water. The irrigator tube and siphon assembly can be rinsed easily by attaching a hose between the tip of the irrigator tube and water faucet and backwashing fresh water through the tube.

¹Chlorox, or its equivalent has been found satisfactory for this purpose.

7.4 Occasionally the holes in the tip of the irrigator tube may become clogged by a particle of sand. If the obstruction cannot be freed by any other method use a pin or other sharp object to force it out, using extreme care not to enlarge the size of the opening.

8. OPERATOR QUALIFICATIONS

8.1 Before an operator is allowed to perform the sand equivalent test by either the manual method or the hand method, the operator must meet certain qualification requirements for that method. Although the qualification requirements are identical for both methods, an operator shall be permitted to use only that method for which he has qualified.

8.1.1 The operator must be capable of obtaining consistent sand equivalent test results on representative samples of any given material when the test is performed in accordance with the prescribed procedure for that particular method. An operator's test results are considered to be consistent if the individual results of three tests performed on representative samples of any given material do not vary by more than ± 4 points from the average of these tests.

8.1.2 The average of three tests by an operator on any given material must correspond within ± 4 points with the average of three tests on the same material when tested using the mechanical shaker method (Referee Method).

8.2 If an operator is not capable of obtaining consistent results with the manual shaker method, or if results do not agree with results obtained by the mechanical shaker method, the operator is not to perform the sand equivalent test using the manual shaker until the operator has perfected the technique sufficiently to bring test results into the specified limits without adjusting the required number of cycles.

8.3 If an operator is capable of obtaining consistent results when qualifying for the hand method, but the average of results does not agree within the prescribed limits of the average of three results by the mechanical shaker method, the operator shall adjust the number of shaking cycles sufficiently to cause results to agree with those by the mechanical shaker method. Determine the required adjustment in the shaking cycles by the following method:

8.3.1 Estimate the adjusted number of shaking cycles required. Increase the number of cycles to obtain a lower sand equivalent test result or decrease the number of cycles to obtain a higher sand equivalent test result. Perform three tests at the adjusted number of cycles. Strive to maintain the prescribed shaking rate of 180 cycles per minute. Compare the average of the three test results using the adjusted number of strokes with the average obtained by the mechanical shaker method. If necessary, readjust the number of shaking cycles until the average result of three tests at the adjusted number of cycles is within ± 4 points of the average obtained by the mechanical shaker method.

8.4 The \pm points is a minimum qualification and should not be considered perfection. Each operator should strive to perfect his technique to obtain results equivalent to those of the mechanical shaker method.

8.5 Operators should be required to perform qualification tests whenever their results tend to vary appreciably from those obtained using the mechanical shaker method. Qualification tests should be made at regular intervals to assure a reasonable degree of accuracy and standardization of test results.

Standard Method of Test for

Moisture-Density Relations of Soils Using a 4.535 kg (10 lb.) Rammer and a 457.2 mm (18 in.) Drop WFLHD Designation: T 180-94 (Modified AASHTO T 180)

1. SCOPE

1.1 This method of test is intended for determining the relationship between the moisture content and density of soils when compacted in a given mold of a given size with a 4.535 kg (10 lb.) rammer dropped from a height of 457.2 mm (18 in.). Four alternate procedures are provided as follows:

Method A - A 101.6 mm (4 in.) mold; soil material passing a 4.75 mm (No. 4) sieve (Sections 3 and 4).

Method B - A 152.4 mm (6 in.) mold; soil material passing a 4.75 mm (No. 4) sieve (Sections 5 and 6).

Method C - A 101.6 mm (4 in.) mold; soil material passing a 19.0 mm (3/4 in.) sieve (Sections 7 and 8).

Method D - A 152.4 mm (6 in.) mold; soil material passing a 19.0 mm (3/4 in.) sieve (Sections 9 and 10).

1.2 The method to be used should be indicated in the specifications for the material being tested. If no method is specified, the provisions of Method D shall govern.

2. Apparatus

2.1 **Molds** - The molds shall be solid-wall, metal cylinders manufactured with dimensions and capacities shown in 2.1.1 and 2.1.2 below. They shall have a detachable collar assembly approximately 60 mm (2-3/8 in.) in height, to permit preparation of compacted specimens of soil-water mixtures of the desired height and volume. The mold and collar assembly shall be so constructed that it can be fastened firmly to a detachable base plate made of the same material.

Note 1 - Alternate types of molds with capacities as stipulated herein may be used, provided the test results are correlated with those of the solid-wall mold on several soil types and the same moisture-density results are obtained. Records of such correlation shall be maintained and readily available for inspection when alternate types of molds are used.

2.1.1 A 101.6 mm (4 in.) mold having a capacity of $0.000943 \pm 0.000008 \text{ m}^3$ [$1/30 (0.0333) \pm 0.0003 \text{ cu. ft.}$] with an internal diameter of $101.6 \pm 0.406 \text{ mm}$ ($4.00 \pm 0.016 \text{ in.}$) and a height of $116.43 \pm 0.127 \text{ mm}$ ($4.584 \pm 0.005 \text{ in.}$).

2.1.2 A 152.4 mm (6 in.) mold having a capacity of $0.002124 \pm 0.000021 \text{ m}^3$ [$1/13.33 (0.07500) \pm 0.00075 \text{ cu. ft.}$] with an internal diameter of $152.4 \pm 0.6604 \text{ mm}$ ($6.000 \pm 0.026 \text{ in.}$) and a height of $116.43 \pm 0.127 \text{ mm}$ ($4.584 \pm 0.005 \text{ in.}$) as shown in Fig. 1.

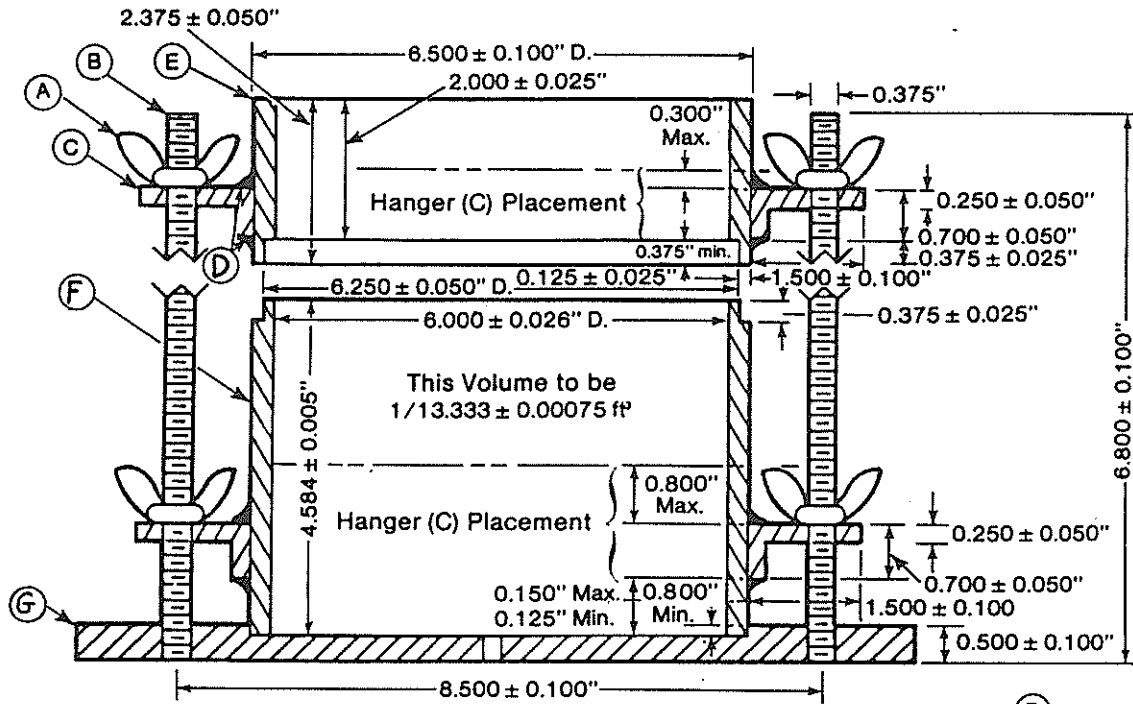

- (A) Wing nut (4)
- (B) Stud (2)
- (C) Hanger (4)
- (D) Weld (Top and Bottom of Each Hanger)
- (E) Collar (1)
- (F) Mold (1)
- (G) Base plate (1)

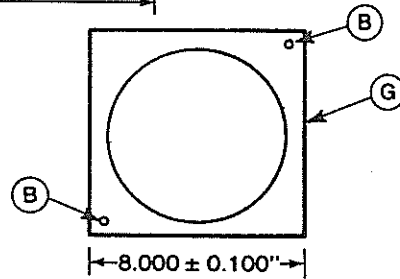

Location of Studs in Base Plate

Metric Equivalents					
in.	mm.	in.	mm.	in.	mm.
0.125 ± 0.025	3.18 ± 0.64	0.700 ± 0.050	17.78 ± 1.27	6.000 ± 0.026	152.40 ± 0.66
0.150	3.81	0.800	20.32	6.250 ± 0.050	158.75 ± 1.27
0.250 ± 0.050	6.35 ± 1.27	1.500 ± 0.100	38.10 ± 2.54	6.500 ± 0.100	165.10 ± 2.54
0.300	7.62	2.00 ± 0.025	50.80 ± 0.64	6.800 ± 0.100	172.72 ± 2.54
0.375 ± 0.025	9.53 ± 0.64	2.375 ± 0.050	60.33 ± 1.27	8.000 ± 0.100	203.20 ± 2.54
0.500 ± 0.100	12.70 ± 2.54	4.584 ± 0.005	116.43 ± 0.13	8.500 ± 0.100	215.90 ± 2.54

$$1/13.333 \pm 0.00075 \text{ ft}^3 = 0.002123 \pm 0.000021 \text{ m}^3$$

Fig. 1. Cylindrical Mold and Base Plate (6" Mold)

2.1.3 Molds Out of Tolerance Due to Use - A mold that fails to meet manufacturing tolerances after continued service may remain in use provided those tolerances are not exceeded by more than 50 percent; and the volume of the mold, calibrated in accordance with Par. 4 (Calibration of Measure) of AASHTO T 19, Test for Unit Weight of Aggregate, is used in the calculations.

2.2 Rammer:

2.2.1 Manually Operated - Metal rammer having a flat circular face of 50.8 ± 0.127 mm (2.000 ± 0.005 in.) diameter, a wear tolerance of 0.13 mm (0.005 in.) and weighing 4.5359 ± 0.0091 kg (10.00 ± 0.02 lb.). The rammer shall be equipped with a suitable guide sleeve to control the height of drop to a free fall of 457.2 ± 1.524 mm (18.00 ± 0.06 (or 1/16) in.) above the elevation of the soil. The guide sleeve shall have at least 4 vent holes, no smaller than 9.5 mm (3/8 in.) diameter, spaced approximately 90 deg. (1.57 rad) apart and approximately 19 mm (3/4 in.) from each end; and shall provide sufficient clearance so the free fall of the rammer shaft and head is unrestricted.

Note 2 - The term weight is temporarily used in this standard because of established trade usage. The word is used to mean both force and mass and care must be taken to determine which is meant in each case (SI unit for force = newton and for mass = kilogram).

2.2.2 Mechanically Operated - A metal rammer which is equipped with a device to control the height of drop to a free fall of 457.2 ± 1.524 mm (18.00 ± 0.06 (or 1/16) in.) above the elevation of the soil and uniformly distributes such drops to the soil surface. The rammer shall have a flat circular face 50.8 ± 0.127 mm (2.000 ± 0.005 in.) diameter, a wear tolerance of 0.13 mm (0.005 in.) and a manufactured weight of 4.5359 ± 0.0091 kg (10.00 ± 0.02 lb.).

Note 3 - The mechanical rammer apparatus shall be calibrated with several soil types and the weight of the rammer adjusted, if necessary, to give the same moisture-density results as with the manually operated rammer.

It may be impractical to adjust the mechanical apparatus so the free fall is 457.2 mm (18 in.) each time the rammer is dropped, as with the manually operated rammer. To make the adjustment of free fall, the portion of loose soil to receive the initial blow should be slightly compressed with the rammer to establish the point of impact from which the 457.2 mm (18 in.) drop is determined, subsequent blows on the layer of soil being compacted may all be applied by dropping the rammer from a height of 457.2 mm (18 in.) above the initial-setting elevation; or, when the mechanical apparatus is designed with a height adjustment for each blow, all subsequent blows should have a rammer free fall of 457.2 mm (18 in.) measured from the elevation of the soil as compacted by the previous blow.

2.2.3 Rammer Face - The circular face rammer shall be used but a sector face rammer may be used as an alternative provided the report shall indicate type of face used other than the 50.8 mm (2 in.) circular face and it shall have an area equal to that of the circular face rammer.

2.3 Sample Extruder - A jack, lever, frame, or other device adapted for the purpose of extruding compacted specimen from the mold.

2.4 Balances and Scales - A balance or scale having a capacity of approximately 11.5 kg and a sensitivity and readability to 5 g, or a balance or scale of at least 25 lb. capacity having a sensitivity and readability to 0.01 lb. Also a balance of at least 1 kg capacity with a sensitivity and readability to 0.1 g.

Note 4 - The capacity of the metric balance or scale should be approximately 11.5 kg when used to weigh the 152.4 mm (6 in.) mold and compacted, moist soil; however, when the 101.6 mm (4 in.) mold is used, a balance or scale of lesser capacity than 11.5 kg may be used, if the sensitivity and readability is 5 g.

2.5 Drying Oven - A thermostatically controlled drying oven capable of maintaining a temperature of 110 ± 5 C (230 ± 9 F) for drying moisture samples.

2.6 Straightedge - A hardened-steel straightedge at least 254 mm (10 in.) in length. It shall have one beveled edge, and at least one longitudinal surface (used for final trimming) shall be plane within 0.01 percent of length within the portion used for trimming the soil.

Note 5 - The beveled edge may be used for final trimming if the edge is true within a tolerance of 0.1 percent of length; however, with continued use, the cutting edge may become excessively worn and not suitable for trimming the soil to the level of the mold. The straightedge should not be so flexible that trimming the soil surface with the cutting edge will cause a concave soil surface.

2.7 Sieves - 50, 19.0, and 4.75 mm sieves conforming to the requirements of AASHTO M 92 for Sieves for Testing Purposes.

2.8 Mixing Tools - Miscellaneous tools such as mixing pan, spoon, trowel, spatula, etc., or a suitable mechanical device for thoroughly mixing the sample of soil with increments of water.

2.9 Containers - Containers for moisture content samples, made of metal or other suitable material, and with close-fitting lids to prevent loss of moisture prior to or during weighing.

Methods A, B, and C are not normally applicable to FLH Contracts and have been deliberately omitted from this test standard.

METHOD D

9. SAMPLE

9.1 If the soil sample is damp when received from the field, dry it until it becomes friable under a trowel. Drying may be in air or by use of drying apparatus such that the temperature of the samples does not exceed 60 C (140 F). Then, thoroughly break up the aggregations in such a manner as to avoid reducing the natural size of individual particles.

9.2 Sieve an adequate quantity of the representative pulverized soil over the 19.0 mm sieve. Discard the coarse material, if any, retained on the 19.0 mm sieve.

Note 8 - If it is advisable to maintain the same percentage of coarse material (passing a 50 mm sieve and retained on a 4.75 mm sieve) in the moisture-density sample as in the original field sample, the material retained on the 19.0 mm sieve shall be replaced as follows: Sieve an adequate quantity of the representative pulverized soil over the 50 mm and 19.0 mm sieves. Discard the coarse material retained on the 50 mm sieve. Remove the material passing the 50 mm sieve and retained on the 19.0 mm sieve and replace it with an equal mass of material passing the 19.0 mm sieve and retained on the 4.75 mm sieve. Take the material for replacement from the remaining portion of the sample.

Note 9 - For one point proctors, the correction, if required, for different percents of plus 4.75 mm (No. 4) shall be determined in accordance with AASHTO T 224.

9.3 Select a representative sample, weighing approximately 11 kg (25 lbs.) or more, of the soil prepared as described in 9.1 and 9.2.

10. PROCEDURE

10.1 Thoroughly mix the selected representative sample with sufficient water to dampen it to approximately four percentage points below optimum moisture content.

10.2 Form a specimen by compacting the prepared soil in the 152.4 mm (6 in.) mold (with collar attached) in five approximately equal layers to give a total compacted depth of about 127 mm (5 in.). Compact each layer by 56 uniformly distributed blows from the rammer dropping free from a height of 457.2 mm (18 in.) above the elevation of the soil when a sleeve-type rammer is used, or from 457.2 mm (18 in.) above the approximate elevation of each finally compacted layer when a stationary mounted type of rammer is used. During compaction, the mold shall rest firmly on a dense, uniform, rigid and stable foundation. Each of the following has been found to be a satisfactory base on which to rest the mold during compaction of the soil: A block of concrete, weighing not less than 91 kg (200 lbs.) supported by a relatively stable foundation; a sound concrete floor; and for field application, such surfaces as found in concrete box culverts, bridges, and pavements.

10.2.1 Following compaction, remove the extension collar, carefully trim the compacted soil even with the top of the mold by means of the straightedge, and weigh the mold and moist soil in kilograms to the nearest 5 grams or in pounds to the nearest 0.01 lb. For molds conforming to tolerances given in 2.1.2 and masses recorded in kilograms, multiply the mass of the compacted specimen and the mold, minus the weight of the mold, by 470.74, and record the result as wet density, W_1 , in kilograms per cubic meter, of compacted soil. For molds conforming to the tolerances given in 2.1.2, and masses recorded in pounds, multiply the mass of the compacted specimen and the mold, minus the mass of the mold, by 13.33, and record the result as the wet density, W_1 , in pounds per cubic foot, of compacted soil. For used molds out of tolerance by not more than 50 percent (2.1.3), use the factor for the mold as determined in accordance with Par. 4 (Calibration of Measure), AASHTO T 19.

10.3 Remove the material from the mold and slice vertically through the center. Take a representative sample of the material from one of the cut faces, weigh immediately, and dry in an oven at 110 ± 5 C (230 ± 9 F) for at least 12 h, or to constant mass, to determine the moisture content. The moisture content sample shall weigh not less than 500 g.

10.4 Thoroughly break up the remainder of the material until it will pass a 19.0 mm sieve and 90 percent of the soil aggregations will pass a 4.75 mm sieve, as judged by eye, and add to the remaining portion of the sample being tested. Add water in sufficient amounts to increase the moisture content of the soil sample by one or two percentage points, and repeat the above procedure for each increment of water added. Continue this series of determinations until there is either a decrease or no change in the wet unit mass, W_1 , per cubic meter (cubic foot) of compacted soil.

Note 10 - This procedure has been found satisfactory in most cases. However, in instances where the soil material is fragile in character and will reduce significantly in grain size due to repeated compaction, and in cases where the soil is heavy-textured clayey material into which it is difficult to incorporate water, a separate and new sample shall be used in each compaction test. In these cases, separate samples shall be thoroughly mixed with amounts of water sufficient to cause the moisture contents of the samples to vary by approximately two percentage points. The moisture contents selected shall bracket the optimum moisture content (at least two points above and at least two points below optimum), thus providing samples which, when compacted, will increase in mass to the maximum density and then decrease in mass. Oven dried samples of soil-water mixtures shall be placed in covered containers and allowed to stand for not less than 12 h before making the moisture-density test.

CALCULATIONS AND REPORT

11. CALCULATIONS

11.1 Calculate the moisture content and the dry mass of the soil as compacted for each trial as follows:

$$w = \frac{A-B}{B-C} \times 100$$

and

$$W = \frac{W_1}{w+100} \times 100$$

Where:

- w = percentage of moisture in the specimen,
- A = mass of the container and wet soil,
- B = mass of the container and dry soil,
- C = mass of the container,
- W = dry density in kg/m^3 (lbs. per cu. ft.) of compacted soil, and
- W_1 = wet density in kg/m^3 (lbs. per cu. ft.) of compacted soil.

12. MOISTURE-DENSITY RELATIONSHIP

12.1 The calculations in 11.1 shall be made to determine the moisture content and corresponding oven-dry density (unit mass) in kilograms per cubic meter (pounds per cubic foot) for each of the compacted samples. The oven-dry densities of the soil shall be plotted as ordinates and corresponding moisture content as abscissas.

12.2 **Optimum Moisture Content** - When the densities and corresponding moisture contents for the soil have been determined and plotted as indicated in 12.1, it will be found that by connecting the plotted points with a smooth line, a curve is produced. The moisture content corresponding to the peak of the curve shall be termed the "optimum moisture-content" of the soil under the above compaction.

12.3 **Maximum Density** - The oven-dry density in kilograms per cubic meter (pounds per cubic foot) of the soil at optimum moisture content shall be termed "maximum density" under the above compaction.

13. REPORT

13.1 The report shall include the following:

13.1.1 The method used (Method A, B, C, or D).

13.1.2 The optimum moisture content.

13.1.3 The maximum density in kg/m^3 (lb/ft^3).

13.1.4 In Methods C and D, whether the 19.0 mm material was removed or replaced.

13.1.5 Type of face if other than 50.8 mm (2 in.) circular.

(INTENTIONALLY LEFT BLANK)

Standard Method of

Sampling Hydrated Lime or Mineral Filler WFLHD Designation: T 218-94 (Modified AASHTO T 218)

1. SCOPE

1.1 This method covers the procedure for sampling hydrated lime or mineral filler from various conveyors, points of shipment, and while in various states of storage.

2. APPARATUS

2.1 Apparatus shall consist of a 50 mm (2 in.) wide paint brush, 4 liter (1 gal.) buckets (or other container of approximately that capacity) with double seal friction lids (or other sealing method) and suitable lengths of sampling tubes such as 25 mm (1 in.) diameter and 2.5 m (8 ft.) in length, and 19 mm (3/4 in.) in diameter and 1 m (3 ft.) in length, with suitable diagonal cut on one end.

3. SAMPLING PROCEDURE FOR POWDERED LIME OR MINERAL FILLER IN BULK

3.1 Being loaded or recently loaded into tank trucks, railway hopper cars, or box cars - Take a representative 2 liter (1/2 gal.) portion of the powdered lime or mineral filler to be analyzed and place it in a 4 liter (1 gal.) bucket. Fit the bucket with a tight-fitting lid. Clean lime or mineral filler from the groove before placing lid; brushing with a 50 mm (2 in.) paint brush has been found to be satisfactory for this purpose.

Note 1 - These sample buckets shall be only half filled with sample material so that subsequent mixing may take place within the bucket itself. Half filling the container will allow sufficient space to permit proper agitation during subsequent mixing operations. The sample bucket shall be dry and clean so as to prevent sample contamination.

3.1.1 Tank trucks or railroad cars being loaded with material shall be sampled during the loading operation by inserting the bucket into the flowing stream of material if conditions permit. The sampler should exercise due discretion in taking samples during the loading operation so that the total sample obtained is representative of the material. If material is being loaded from one or more bins or silos or from silo and plant production or various combinations, the composite sample contained in the bucket shall be representative of the composite material. Insofar as the possibility of poor mixing may exist, the sampler may at his discretion take separate samples of individual portions of material being loaded. This is particularly advisable where, in order to effect a complete load, material is being loaded from more than one plant source.

Note 2 - If conveyors are being loaded in the rain, make every effort to insure that the material contained in the sample bucket is typical of the material being shipped. In cases of suspected moisture difficulty, it is always advisable to rod the load with the long sampling tubes.

3.1.2 Trucks shall be rodded in three separate places from the top through the openings provided. Rod the center of the load and the two ends; rodding the material vertically or diagonally so as to obtain a composite 2 liter (1/2 gal.) portion of material which will be representative insofar as possible of the material.

3.1.3 If loading has been completed rather recently and weather conditions permit, "scoop" samples may be taken from the top of the loaded material and depending upon the plant source of the material, the sampler may consider this sample to be representative. If the load is composed of one or more portions from more than one plant source, a "scoop" sample may be taken from the top of each portion during the loading operation, and these samples may either be combined or submitted separately for analysis.

3.1.4 Added precautions are necessary in sampling railway hopper cars. The sampler should request assistance from plant personnel in attempting to sample material in hopper cars. From the standpoint of safety it is advisable that two people lift the heavy steel doors on as many openings as the sample requires be opened to allow for proper sampling. Should the level of material in the hopper car be too low to obtain a "scoop" sample with a minimum of hazard, then the material should be rodded in as many places as the sampler feels necessary, or the option of sampling from the loading spout with the assistance of plant personnel may be employed. Rodding the entire load in the prescribed fashion is the preferred method to be employed, but the sampler shall have the option of employing such optional sampling procedures. With the exceptions noted, the details and principles suggested for the sampling of tank trucks while being loaded, or recently loaded, also apply in the case of railway hopper cars under like conditions.

3.2 In storage awaiting shipment - This procedure applies to material loaded and left standing awaiting shipment in what might be considered a modification of bin storage. These loads in so-called "truck-storage" should be sampled by rodding the material with the long 2.5 m (8 ft.) sampling tube. The sampler shall decide if the trucks have been loaded recently enough to permit "scoop" sampling or if sufficient time has elapsed since loading to make it advisable to rod the material so as to obtain a representative "through" sample of the material. The sampler shall base all decisions concerning the optional forms of sampling on what he considers will yield a representative sample of the material being shipped within the practicalities of the situation at hand.

3.3 At job site - A representative 2 liter (1/2 gal.) portion of material should be taken by rodding the material in the rail car or tank truck (before unloading) in at least three positions, the center and on both ends. Use the long 2.5 m (8 ft.) sampling tube.

Note 3 - The material in rail cars should be sampled by rodding the material before unloading, thus preventing the possibility of material contamination after unloading and possibility of obtaining an otherwise unrepresentative composite sample. Due to varying conditions of storage, and the possibility of sample contamination due to moisture, exposure to air, etc., "scoop" samples are not recommended.

3.4 At loading spouts feeding from plant production, from bin storage or at bagger outlet spouts being supplied by either plant production or bin storage - Make sure that a reasonable quantity of material has moved through the feed system so that the possibility of contamination by material of long standing will be minimized. The 2 liter (1/2 gal.) sample should be taken from loaded bags rather than from the bagger outlet spout, since sampling from the latter often tends to be nonrepresentative due to the presence of non-fresh or contaminated material in the outlet itself and the usual spillage which occurs in attempting to sample at the bagger outlet spout does not add to overall plant cleanliness.

Note 4 - Samplers shall keep in mind that no plant equipment shall be operated by sampling personnel. In general, it should be the responsibility of the plant personnel to operate all equipment and to make the sample available to the sampler. Reasonable and safe sampling facilities shall be arranged for by the producer and provided wherever possible, provided such arrangements meet with the principles involved in obtaining a truly representative sample of the material shipped.

3.5 From loaded silos or storage bins - There is usually a considerable lack of mixing in the material contained in bulk hydrate or mineral filler storage bins. Stratification and flow patterns tend to occur. Experience in attempting to correlate silo samples with samples obtained from rodded trucks loaded from such silos indicates poor correlation. Wherever possible, avoid taking silo or bin storage samples and concentrate the sampling on individual loads or shipments rather than taking composite samples of larger reservoirs, which due to poor mixing or other conditions prevalent may contain portions of potentially unsatisfactory material which a composite sample might indicate to be satisfactory.

Note 5 - Screw conveyors being supplied by either plant production or bin storage are dangerous sources for sampling material, and no attempt should be made to obtain material at such locations.

4. SAMPLING PROCEDURE FOR BAGGED HYDRATED LIME OR BAGGED MINERAL FILLER

4.1 From warehouse stock consigned for shipment - If necessary, request that plant personnel make the material available to the sampler. Take care not to sample amongst bagged material which is stacked dangerously high. If necessary, the sampler should ask plant personnel to make available the sacks which he desires to sample. Choice of sacks should be made on the basis of obtaining a representative sample of the lot being shipped. If the entire lot consigned for an individual truck or group of trucks is from several different warehouse lots, the sampler may at his discretion take samples from the separate lots which comprise the whole. The sampler should use the short sampling rod and, through the sack loading spout, take sufficient diagonal roddings to insure a representative portion from each sack but not a sufficient quantity to materially reduce the poundage being supplied in any individual sack. For this reason and for the obvious reason of attempting to obtain a representative sample, it is suggested that at least 4 to 6 sacks from each lot to be inspected be sampled. These sampled lots may be combined to form one sample representing the individual truck or they may be submitted for analysis separately. Generally

speaking, at least 6 sacks should be sampled to represent each truck being shipped from consignments previously produced, and stored warehouse stock to obtain the 2 liter (1/2 gal.) sample.

4.2 From bag loads - If the truck is partially loaded, the sampler may choose sacks at his discretion to effect a representative sample and may also sample floor stock consigned for the partially loaded truck so as to obtain a representative sample. He may combine sampling from a partially loaded truck with material being produced by obtaining a sample at the bagger but, due to the usual spillage and interruption of plant activities, this bagger sampling option is not recommended. Rather than sampling at the bagger, it would be preferable to sample the bags being loaded on the truck or the loaded bags at various stages of the loading operation. This matter of which bags to sample should be at the discretion of the sampler; however, the sacks chosen for sampling should be selected from various points in the load so as to effect a representative sample. In sampling from loaded trucks and rail cars, the short sampling rod should be used to obtain a total of a 2 liter (1/2 gal.) sample from at least 6 sacks of material. Insert the sampling rod through the loading valve and take several "through" samples diagonally from each sack, taking care not to puncture the bottom or sides of the sack with the sharp sampling tube.

4.3 From bags or storage bins at the point of delivery - Sampling at the point of delivery may be as described in 4.1 or 4.2 or in accordance with the following: The sampler may use a scoop to obtain small portions from a bag or storage bin. Several points within the bag or storage bin should be sampled and combined to make up a 2 liter (1/2 gal.) sample.

Standard Method of Test for
Correction for Coarse Particles in the Soil
Compaction Test
WFLHD Designation: T 224-94 (Modified AASHTO T 224)

1. SCOPE

1.1 This method describes a procedure whereby the maximum soil density determined by AASHTO T 99 or T 180 may be adjusted to compensate for differing percentages of coarse particles retained on the 4.75 mm sieve when performing the density of soil and soil-aggregate in-place.

1.2 The following applies to all specified limits in this standard: For the purpose of determining conformance with these specifications, an observed value or a calculated value shall be rounded off to the nearest unit in the last right-hand place of figures used in expressing the limiting value, in accordance with the rounding-off method of AASHTO R 11, Recommended Practice For Indicating Which Places of Figures Are To Be Considered Significant In Specified Limiting Values.

2. OUTLINE OF METHOD

2.1 When Method A or Method B of T 99 or T 180 is employed, the maximum density shall be determined on the soil fraction passing the 4.75 mm sieve.

2.1.1 The correction chart (Figure 1) for Method A or Method B of T 99 or T 180 will determine the corrected maximum density from the percentage of coarse particles retained on the 4.75 mm sieve that may be found when performing the density of soil and soil-aggregate in-place. (see FHWA Form 1636).

2.2 When Method C or Method D of T 99 or T 180 is employed, the maximum density shall be determined on the soil fraction passing the 19.0 mm sieve.

2.2.1 The correction chart (Figure 2) for Method C or Method D will determine the adjusted maximum dry density from the percentage of coarse particles retained on the 4.75 mm sieve that may be found when performing the density of soil and soil-aggregate in-place.

2.2.1.1 Figure 2 shows the maximum dry density may or may not be determined on coarse particles replaced as specified under T 99 or T 180, Note 7 and Note 8. However, the total percentage of coarse particles passing the 19.0 mm and retained on the 4.75 mm sieve will have to be determined along with the percentage of coarse particles (plus 4.75 mm sieve) found when performing the density of soil and soil-aggregate in place. (see FHWA form 1635, case 1).

2.2.2. The correction chart (Figure 3) for Method C or Method D will determine the adjusted maximum dry density from the percentage of coarse particles retained on the 19.0 mm sieve that may be found when performing the density of soil and soil-aggregate in-place (Appendix A1.2 and A1.2.1) (see FHWA form 1635, case 2).

2.3 Significant figures are as follows:

2.3.1 Maximum dry density of the fine material passing the 4.75 mm sieve (D_f) 0.1 pcf.

2.3.2 Bulk specific gravity of the coarse material retained on the 4.75 mm sieve (D_c) 0.01.

2.3.3 Percent by weight of coarse particles of material retained on the 4.75 mm sieve expressed as a decimal (P_c) 0.001.

2.3.4 Adjusted maximum dry density of the total material (D) 0.1 pcf.

Note 1 - Methods A, B, and D of AASHTO T 99 and Methods A, B, and C of AASHTO T 180 are not normally applicable to FLH Contracts.

3. ADJUSTMENT EQUATION

3.1 The empirical equation for adjusting the maximum density obtained in accordance with Method A or B with a known percentage of coarse particles to the maximum density of the same soil containing a different percentage of coarse particles is:

$$D_{cor} = (1.00 - P_{cf})D_{max} + 0.9 P_{cf}D_c$$

Where:

- D_{cor} = adjusted maximum dry density of the total material, pcf;
 P_{cf} = percent by weight of coarse particles retained on the 4.75 mm sieve in the sample, expressed as a decimal;
 D_{max} = maximum laboratory dry density of the fine material passing the 4.75 mm sieve, pcf; and
 D_c = 62.4 X bulk specific gravity (oven-dry basis) of the coarse particles retained on the 4.75 mm sieve, pcf.

Note 2 - In the above equation for computing D, 0.9 is an empirical coefficient that is dependent on the value of P_c . A coefficient of 0.9 is normally considered to be adequate in field control of earthwork or base course construction. If a more exact adjustment of the maximum density is desired, the following equation may be used:

$$D = \frac{62.4}{\frac{P_c}{G_m} + \frac{62.4 P_f}{r(D_f)}}$$

Where:

- G_m = bulk specific gravity of the particles retained on the 4.75 mm sieve;
 P_f = percentage of the fine material passing 4.75 mm sieve, expressed as a decimal; and
 r = a coefficient having a value dependent on P_c as shown in the following table.

r	P_c
1.00	0.20 or less
0.99	0.21 - 0.25
0.98	0.26 - 0.30
0.97	0.31 - 0.35
0.96	0.36 - 0.40
0.95	0.41 - 0.45
0.94	0.46 - 0.50
0.92	0.51 - 0.55
0.89	0.56 - 0.60
0.86	0.61 - 0.65
0.83	0.66 - 0.70

4. SOLUTION

4.1 The solution to this equation by nomograph is shown in Figure 1, wherein the maximum density of material passing the 4.75 mm sieve (2.1) determined in the laboratory test is plotted and a line is drawn from this point to a point on the line representing the bulk specific gravity of the coarse particles. When the percentage of coarse particles contained in a field density of soil and soil-aggregate in-place has been determined and plotted on the above line as the abscissa on the chart (Figure 1), the ordinate will give the maximum laboratory dry density corrected to the new percentage of coarse particles.

4.2 Figures 2 and 3 illustrate a solution when Method C or Method D of T 99 or T 180 is utilized (2.2).

5. PRECISION

5.1 Since this correction for coarse particles involves no testing but instead utilizes the results of other tests and mathematically combines the results, determination of the precision and accuracy is not applicable.

APPENDIX

A1. NOTES

A1.1 These methods, described for coarse particle correction, are applicable to one type of soil and soil aggregate material only. If the characteristic of the material changes, then a moisture density relationship (T 99 or T 180) test is performed to determine a new maximum density.

A1.2 AASHTO T 272-82 describes the methods for determining different maximum densities of soil and soil-aggregate materials which reveal certain similarities and trends characteristic of the material type and source.

A1.2.1 Utilization of a Family of Curves--One Point Method (T 272-82) will eliminate a requirement for determining the percentage of coarse particles passing the 19.0 mm and retained on the 4.75 mm sieve when performing Method C or Method D of T 99 or T 180 and the density of soil and soil aggregate in-place. However, the percentage of coarse particles (plus 19.0 mm sieve) found when performing the density of soil and soil-aggregate in-place will have to be determined in order to adjust the T 99 or T 180 Method C or Method D maximum density to compensate for this percentage (Figure 3).

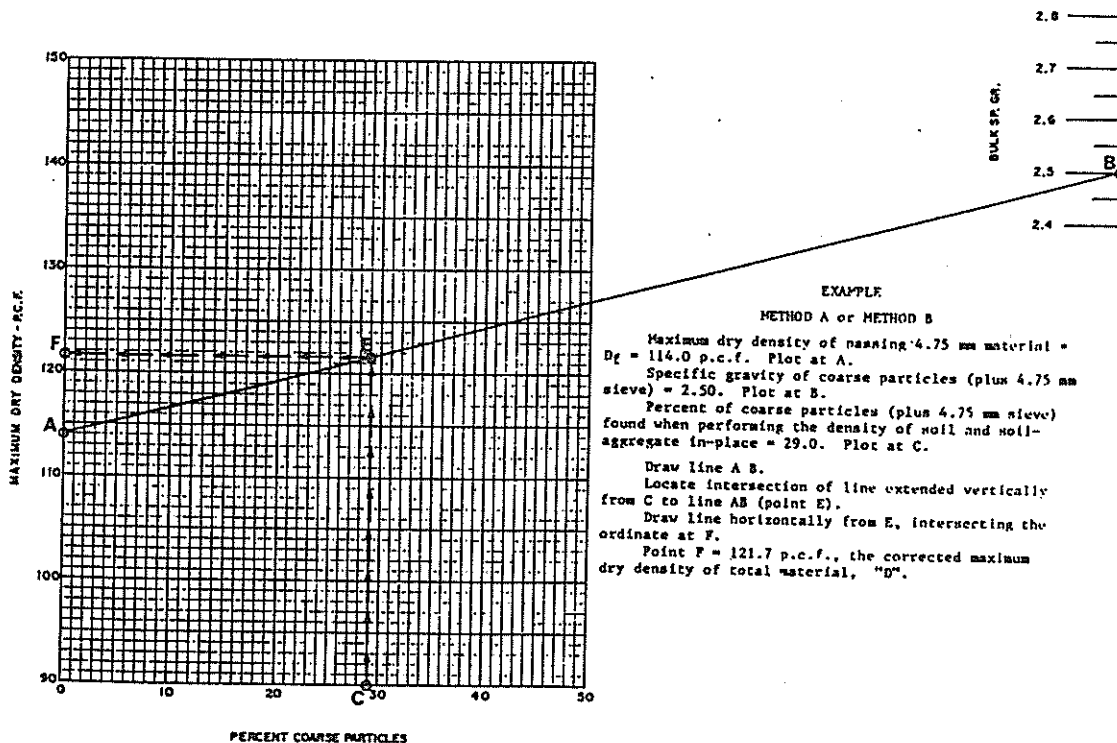

FIGURE 1: Density Correction Chart for Coarse Particles

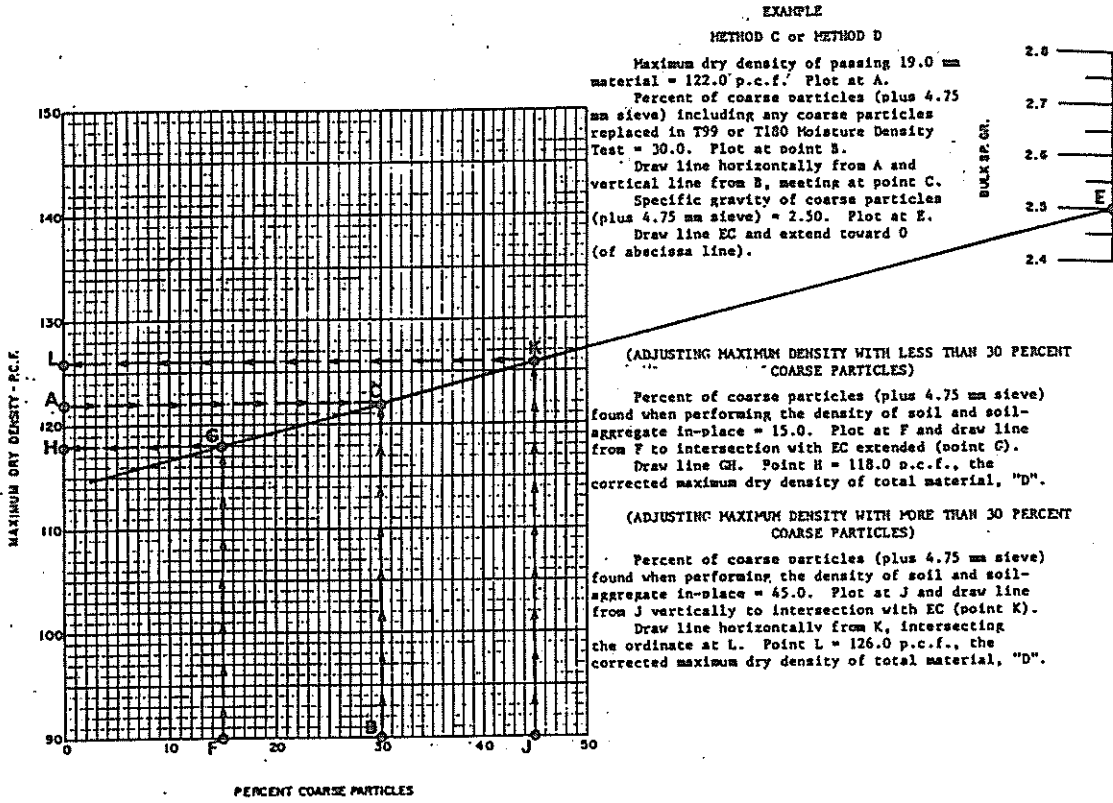

FIGURE 2: Density Correction Chart for Coarse Particles

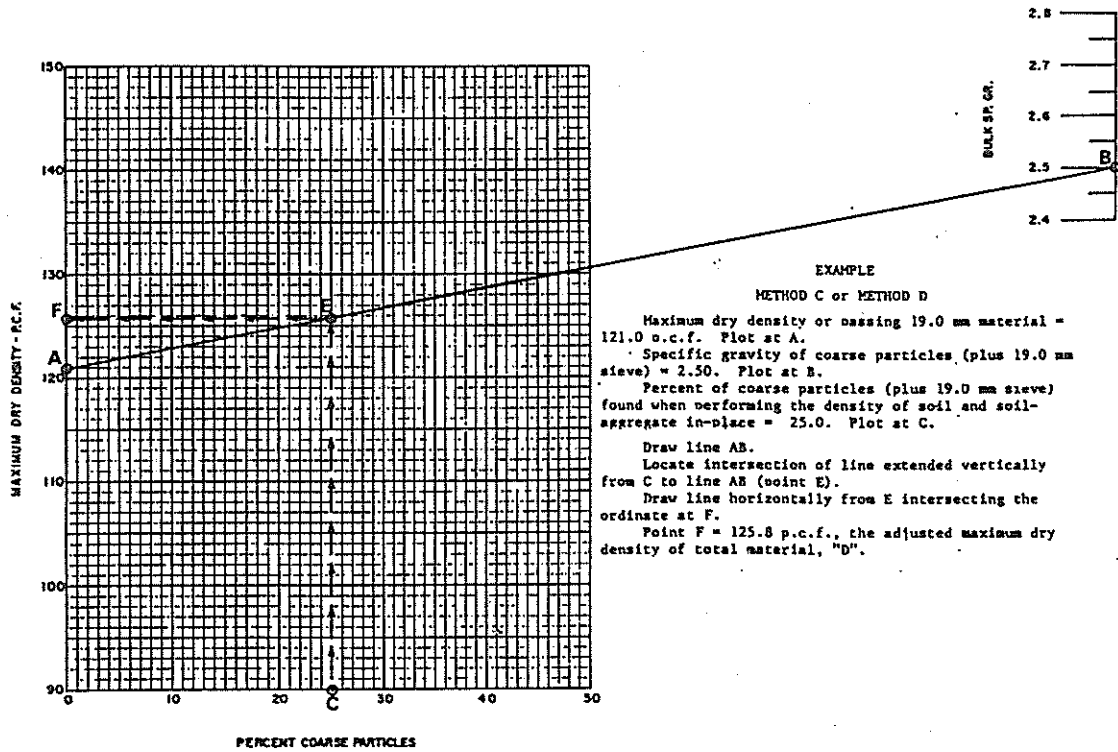

FIGURE 3: Density Correction Chart for Coarse Particles

(INTENTIONALLY LEFT BLANK)

Standard Method of Test for

Density of Soil and Soil-Aggregate in Place by Nuclear Methods (Shallow Depth) WFLHD Designation: T 238-94 (Modified AASHTO T 238)

INTRODUCTION

These methods describe determination of the density of soil and soil-aggregate in place through the use of nuclear equipment. In general, the total or wet density of the material under test is determined by placing a gamma source and a gamma detector either on, into, or adjacent to the material under test. These variations in test geometry are presented as the backscatter, direct transmission, or air gap approaches. The intensity of radiation detected is dependent in part upon the density of the material under test. The radiation intensity reading is converted to measured wet density by a suitable calibration curve. Principles of the nuclear test are discussed in the Appendix, as are some of its advantages and disadvantages. It should be noted that the density determined by these methods is not necessarily the average density within the volume involved in the measurement and that the equipment utilizes radioactive materials which may be hazardous to the health of users unless proper precautions are taken.

Before using any nuclear gages, the user shall first receive training in radiation safety and in the proper care and use of the nuclear equipment.

Due to rapid changes in nuclear gage technology, the methods and procedures described in this test standard are intentionally general in nature and may or may not be totally applicable to a given nuclear gage. Before operating a given model of nuclear gage, the user shall become thoroughly familiar with the manufacturer's operating manual for that gage, shall follow the procedures and recommendations of the manufacturer at all times and shall subscribe to procedures described hereafter as applicable.

1. SCOPE

1.1 This method covers the determination of the total or wet density of soil and soil-aggregate in place by the attenuation of gamma rays where the gamma source or gamma detector, or both, remain at or near the surface. This test method is also applicable to the determination of total density of bituminous or portland cement concrete pavements. The methods described are normally suitable to a test depth of approximately 50 to 300 mm (2 to 12 in.), depending on the test geometry used.

1.2 Three methods are described as follows:

	<u>Sections</u>
Method A - Backscatter	5 to 7
Method B - Direct Transmission	8 to 10
Method C - Air Gap	11 to 14

2. SIGNIFICANCE

2.1 The methods described are useful as rapid, nondestructive techniques for the in place determination of wet density of soil and soil-aggregate. The fundamental assumptions inherent in the methods are that Compton scattering is the dominant interaction and that the material under test is homogeneous.

2.2 The methods are suitable for control and acceptance testing of soils and soil-aggregate for construction, as well as for use in research and development. Test results may be affected by chemical composition, sample heterogeneity, and the surface texture of the material being tested. The techniques also exhibit spatial bias in that the apparatus is more sensitive to certain regions of the material under test.

3. CALIBRATION

4. PRECISION

Sections 3. and 4. deal with the calibration and precision requirements of nuclear gages. These sections are not normally applicable to field testing as the calibration and precision checks on the equipment are usually made at the point of manufacture and/or at the central laboratory. These sections have therefore been deliberately omitted from this test standard.

METHOD A - BACKSCATTER

5. APPARATUS

5.1 Gamma Source - Shall be an encapsulated and sealed radioisotopic source.

5.2 Gamma Detector - May be any suitable type.

5.3 Readout Device - Shall be a suitable scaler. Usually the readout device will contain the high-voltage supply necessary to operate the detector, and a low-voltage power supply to operate the readout and accessory devices.

5.4 Housing - The source, detector, readout device, and power supply shall be in housings of rugged construction that are moisture and dust proof.

Note 4 - The gamma source, detector, readout device, and power supply may be housed separately or combined and integrated with a nuclear moisture measuring system.

5.5 Reference Standard - Reference standard of uniform, unchanging density shall be provided with each gage for the purpose of checking equipment operation and background count, and to establish conditions for determining count rate reproducibility.

5.6 Site Preparation Device - A steel plate, straightedge, or other suitable leveling tools may be used to plane the test site to the required smoothness.

6. STANDARDIZATION

6.1 Standardization of equipment on a reference standard is required at the start of each day's use and when test measurements are suspect.

6.2 Warm up the equipment in accordance with the manufacturer's recommendations.

6.3 Take at least four repetitive readings of at least 1 min. each with the gage on the reference standard. This constitutes one standardization check.

6.4 If the mean of the four repetitive readings is outside the limits set by Eq 2, repeat the standardization check. If the second standardization check satisfies Eq 2, the equipment is considered to be in satisfactory operating condition. If the second standardization check does not satisfy Eq 2, the calibration should be checked (contact the central laboratory for further guidance). If the calibration check shows that there is no significant change in the calibration curve, a new reference standard count, N_o , should be established. If the calibration check shows that there is a significant difference in the calibration curve, repair and recalibrate the instrument.

$$N_s = N_o \pm 1.96 (N_o)^{1/2} \quad (2)$$

Where:

N_s = count currently measured in checking the instrument operation on the reference standard (6.3), and

N_o = count previously established on the reference standard (mean of ten repetitive readings).

7. PROCEDURE

7.1 Select a test location where the gage in test position will be at least 150 mm (6 in.) away from any vertical projection.

7.2 Prepare the test site in the following manner:

7.2.1 Remove all loose and disturbed material and additional material as necessary to expose the top of the material to be tested.

Note 5 - The spatial bias should be considered in determining the depth at which the gage is to be seated.

7.2.2 Prepare a horizontal area sufficient in size to accommodate the gage, by planing the area to a smooth condition so as to obtain maximum contact between the gage and material being tested.

7.2.3 The maximum void beneath the gage shall not exceed 3 mm (1/8 in.). Use native fines or fine sand to fill these voids and smooth the surface with a rigid plate or other suitable tool.

Note 6 - The placement of the gage on the surface of the material to be tested is critical to the successful determination of density. The optimum condition is total contact between the bottom surface of the gage and the surface of the material being tested. This is not possible in all cases and to correct surface irregularities use of sand or similar material as a filler is necessary. The depth of the filler should not exceed 3 mm (1/8 in.) and the total area filled should not exceed 10 percent of the bottom area of the gage. Several trial seatings may be required to achieve these conditions.

7.3 Proceed with the test in the following manner:

7.3.1 Seat the gage firmly.

7.3.2 Keep all other radioactive sources away from the gage to avoid affecting the measurement.

7.3.3 Warm up the equipment in accordance with the manufacturer's recommendation.

7.3.4 Secure and record one or more 1 min. readings.

7.3.5 Determine the in-place wet density by use of the calibration curve previously established.

METHOD B - DIRECT TRANSMISSION

8. APPARATUS

8.1 The direct transmission system shall consist of the following units. The exact details of construction of the apparatus may vary; however, the general requirements of 5.1 through 5.6 shall apply in addition to the following:

8.1.1 Probe - Either the gamma source or the detector shall be housed in a probe for inserting in a preformed hole in the material to be tested. The probe shall be marked in increments of 50 mm (2 in.) for tests with probe depths from 50 to 300 mm (2 to 12 in.). The probe shall be so made mechanically that when moved manually to the marked depth desired it will be held securely in position at that depth.

8.1.2 Housing - The source, detector, readout device, probe, and power supply shall be in housings of rugged construction that are moisture and dust proof.

8.1.3 Guide - For forming a hole normal to the prepared surface.

8.1.4 Hole-Forming Device - A hole-forming device, such as an auger or pin, having a nominal diameter equal to or slightly larger than the probe but not to exceed the diameter of the probe by more than 3 mm (1/8 in.), for forming a hole in the material to be tested to accommodate the probe.

9. STANDARDIZATION

9.1 Standardization of equipment on a reference standard is required at the start of each day's use and when test measurements are suspect.

9.2 Warm up the equipment in accordance with the manufacturer's recommendations.

9.3 With the gage on the reference standard provided by the manufacturer and with the probe in the position prescribed by the manufacturer for measuring standard count, take at least four repetitive readings of at least 1 min. each. This constitutes one standardization check.

9.4 If the mean of the four repetitive readings is outside the limits set by Eq 2, repeat the standardization check. If the second set standardization check satisfies Eq 2, the equipment is considered to be in satisfactory operating condition. If the second standardization check does not satisfy Eq 2, the calibration should be checked (contact the central laboratory for further guidance). If the calibration check shows that there is no significant change in the calibration curve, a new reference standard count, N_o , should be established. If the calibration check shows that there is a significant difference in the calibration curve, the instrument should be repaired and recalibrated.

10. PROCEDURE

10.1 Select a test location where the gage in test position will be at least 6 in. (150 mm) away from any vertical projection.

10.2 Prepare the test site in the following manner:

10.2.1 Remove all loose and disturbed material, and remove additional material as necessary to expose the top of the material to be tested.

10.2.2 Prepare a horizontal area, sufficient in size to accommodate the gage, by planing the area to a smooth condition so as to obtain maximum contact between the gage and material being tested.

10.2.3 The maximum void beneath the gage shall not exceed approximately 3 mm (1/8 in.). Use native fines or fine sand to fill these voids and smooth the surface with a rigid plate or other suitable tool. The depth of the filler should not exceed approximately 3 mm (1/8 in.).

10.2.4 Make a hole perpendicular to the prepared surface using the guide (8.1.3) and the hole-forming device (8.1.4). The hole shall be of such depth and alignment that insertion of the probe will not cause the gage to tilt from the plane of the prepared area.

10.3 Proceed with testing in the following manner:

10.3.1 Tilt the gage and extend the probe in the position required for the desired depth of test.

10.3.2 Insert the probe in the hole.

10.3.3 Seat the gage firmly by rotating it about the probe with a back and forth motion.

10.3.4 Pull gently on the gage in the direction that will bring the side of the probe to face the center of the gage so that the probe is in intimate contact with the side of the hole.

10.3.5 Keep all other radioactive sources away from the gage to avoid affecting the measurement.

10.3.6 Warm up the equipment in accordance with the manufacturer's recommendation.

10.3.7 Secure and record one or more 1 min. readings.

10.3.8 Determine the in-place wet density by use of the calibration curve previously established.

METHOD C - AIR GAP

11. APPARATUS

11.1 All apparatus described in Sections 5 and 8.

11.2 Cradle or Spacers - To support the gage at the optimum air gap above the material being tested. The cradles or spacers shall be so designed as to support the gage at optimum height without shielding the base of the gage. Figure 1 shows a typical air-gap cradle that demonstrates the principle. The cradle shown in Fig. 1 is not the only satisfactory method. Other methods which support the gage at the optimum air gap without shielding the base of the gage are satisfactory.

Note 7 - Air-gap calibration curves and optimum air gap may be furnished for each gage by the manufacturer and can be readily checked by the user.

12. DETERMINATION OF OPTIMUM AIR GAP

Section 12. deals with the determination of the optimum air gap. This is normally done by the manufacturer and is not normally performed as a field procedure. Section 12. has therefore been deliberately omitted from this test standard.

13. STANDARDIZATION

13.1 Standardization of equipment on a reference standard is required at the start of each day's use and when test measurements are suspect.

13.2 Warm up the equipment in accordance with the manufacturer's recommendations.

13.3 Take at least four repetitive readings of at least 1 min. each with the gage on the reference standard. This constitutes one standardization check.

Note 8 - The standard count determined in 13.3 is not used in the determination of density by the air-gap method. The purpose of checking the standard count as required by 13.3 is to check that the equipment is in satisfactory operating condition.

13.4 If the mean of the four repetitious readings is outside the limits set by Eq 2, repeat the standardization check. If the second standardization check satisfies Eq 2, the equipment is considered to be in satisfactory operating condition. If the second standardization check does not satisfy Eq 2, the calibration should be checked (contact the central laboratory for further guidance). If the calibration check shows that there is no significant change in the calibration curve, a new reference standard count, N_0 , should be established. If the calibration check shows that there is a significant difference in the calibration curve, the instrument should be repaired and recalibrated.

14. PROCEDURE

14.1 Select a test location where the gage in test position will be at least 150 mm (6 in.) away from any vertical projection. Plane sufficient area to accommodate the gage and cradle.

14.2 Prepare the test site in the following manner:

14.2.1 Remove all loose and disturbed material, and additional material as necessary to expose the top of the material to be tested.

14.2.2 Prepare a horizontal area, sufficient in size to accommodate the gage and cradle, by planing the area to a smooth condition so as to obtain maximum contact between the gage and the material being tested.

14.2.3 The maximum void beneath the gage shall not exceed approximately 3 mm (1/8 in.). Use native fines or fine sand to fill these voids and smooth the surface with a rigid plate or other suitable tool.

Note 9 - The air-gap method requires taking one or more readings in both the backscatter position and the air-gap position. The placement of the gage on the surface of the material to be tested is critical to the successful determination of density. The optimum condition is total contact between the bottom surface of the gage and the surface of the material being tested. This is not possible in all cases and to correct surface irregularities use of sand or similar material as filler is necessary. The depth of the filler should not exceed 3 mm (1/8 in.) and the total area filled should not exceed 10 percent of the bottom area of the gage. Several trial seatings may be required to achieve these conditions.

14.3 Proceed with the test in the following manner:

14.3.1 Seat the gage firmly.

14.3.2 Keep all other radioactive sources away from the gage to avoid affecting the measurement so as not to affect the readings.

14.3.3 Warm up the equipment in accordance with the manufacturer's recommendation.

14.3.4 Secure and record one or more 1 min. readings in the backscatter position.

14.3.5 Place the cradle, set at optimum air gap, on the test site, and place the gage on the cradle so that the gage is directly over the same site used for backscatter reading. When a direct-transmission type gage is used, set the probe in the retracted or backscatter position for this reading.

14.3.6 Take the same number of 1 min. readings in the air-gap position as in the backscatter position (14.3.4).

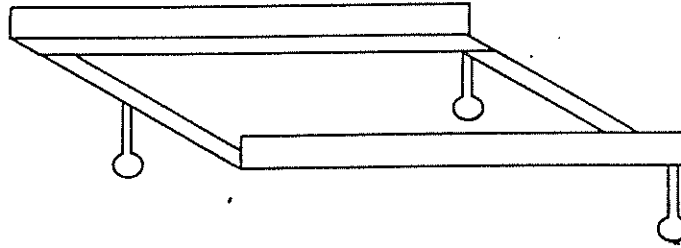

Welded metal approx. 25 by 25 by 3 mm (1 by 1 by 1/8 in.) angle.

Fig. 1 Typical Air-Gap Cradle

14.3.7 Determine the air-gap ratio by dividing counts per minute obtained in the air-gap position (14.3.6) by counts per minute obtained in backscatter position (14.3.4).

14.3.8 Determine the in-place wet density by use of the applicable calibration curve previously established.

Note 10 - The air-gap ratio may be determined by dividing counts per minutes obtained in backscatter position by counts per minute obtained in the air-gap position or vice versa. Whichever ratio is used, a calibration curve using the same ratio must also be used.

APPENDIX

A1. NOTES ON THE NUCLEAR TEST

A1.1 The equipment used in this method is of the surface type as opposed to that designed for use in deep borings. In general, and neglecting the associated electronics, this equipment consists of three principal elements: (1) a nuclear source emitting gamma rays, (2) a detector sensitive to these rays as they are modified by passing through the material being tested, and (3) a counter or scaler with provisions for automatic and precise timing, for determining the rate at which the modified gamma rays arrive at the detector. While rate meters are suitable, in principle, scalers are commonly used. In general any source of gamma rays that are sufficiently numerous and properly energetic can be used in measuring the density of soil and soil-aggregate. Source stability with time, in terms of half-life is an important design consideration and the sources most commonly used are cesium-137 and radium-beryllium with the latter normally being used in dual-purpose instruments that are designed to also determine moisture content. The two detectors most commonly used are gas-filled tubes of the Geiger-Muller type and scintillation crystals, usually of sodium-iodide.

Detectors of the latter type offer the potential of electronically varying the range of engamma rays that are counted. With detectors of the Geiger-Muller type this range is fixed in the design. For most available equipment the source-detector geometry is fixed for backscatter gages and is adjustable to various preselected depths of direct transmission gages.

A1.2 Measurements are made using gamma rays that largely reflect at reduced energy by scattering in, or by, direct transmission through the material under test. In backscatter the rays are emitted into the material from near its surface and some are deflected at reduced energy back to the detector, largely by Compton scattering. In direct transmission the source or detector is inserted in the test materials and, in contrast to the backscatter method, some of the emitted and unshielded rays can presumably follow a straight-line path to the detector. In either source-detector arrangement the number of rays reaching the detector is, over-all, a nonlinear function of the density of the material being tested. For the usual range of soil and soil-aggregate densities the relationship is such that the higher the density of a given material, the lower the count rate.

A1.3 The determination of density by the nuclear means of this method is indirect. To date no theoretical approach has been developed that predicts the count rate for given equipment, geometry, material, and density. As a result the relationship between material density and nuclear-count rate is determined by correlation tests of materials at known average densities. Individual equipment manufacturers supply a calibration curve with each set of their equipment. It has been found that these curves do not necessarily hold for all soils and soil-aggregates because of differences in chemical composition. Apparent variations in calibration curves may also be induced by differences in seating, in background count, and other test variations. Because of these considerations, provisions are included in this method for checking for variations or changes. Different approaches may be used in checking calibration curves and those in more general use are given. For good practice these calibration procedures should be followed with newly purchased equipment and with major component replacements of in-service equipment.

A1.4 The density determined by this method is the wet or total density. It should be noted that the volume of soil or soil-aggregate represented in the measurements is indeterminate and will vary with the source-detector geometry of the equipment used and with the characteristics of the material tested. In general, and with all other conditions constant, the more dense the material, the smaller the volume involved in the measurement. The density so determined is not necessarily the average density within the volume involved in the measurement. Although for the usual surface backscatter test equipment and materials the gages are influenced by 75 to 125 mm (3 to 5 in.) of material, the top 25.4 mm (1 in.) of the material determines about one half of the measured count rate with the result that the observed density is largely determined by the density of the upper layers. For the usual density conditions the total count is largely determined by the upper 75 to 100 mm (3 to 4 in.) of soils and soil-aggregates. Where these materials are of uniform density, this characteristic of this method is of no effect. With the air-gap method the penetration of the backscattered rays is relatively shallow. With direct-transmission gages the effect of vertical density variations may be eliminated. Other problems, however, can be introduced in the mechanics of inserting the source or the detector.

A1.5 The number of gamma rays emitted from a given source over a given time period are statistically random and follow a Gaussian distribution. Because of this the actual number of modified rays that are detected and counted in the density-measuring process should be sufficiently large to minimize the probability that the observed count reflects unacceptable variations. This is reflected in the standard deviation which is the square root of the total count. The over-all system accuracy in determining densities is also statistical in nature and appears to vary with the equipment used, the test conditions of laboratory versus field, as well as with materials and operators. Because of these variables it is not possible to give precise numbers for system accuracy and precision for these methods. It is believed, however, that if the procedures herein are carefully followed, the standard deviation of the nuclear measured values, in terms of accuracy, will not be greater than on the order of some 48 to 80 kg/m³ (3 to 5 lb/ft³) while in terms of precision or repeatability, determined without moving the test equipment, this should not be greater than on the order of 16 kg/m³ (1 lb/ft³).

A1.6 One of the most commonly used sources, cesium-137, is man made and as such its use is regulated by the Federal Government through the Atomic Energy Commission as well as by some state and local governments. Because radium is a naturally occurring material, its use is not now regulated by the Federal Government but is by some state and local governments. Among others, the objectives of these regulations are the use of radioactive materials in a manner safe to the operator and all others. While detailed safety procedures are beyond the scope of this method, the originating committee emphasizes its support of these objectives. It strongly recommends that users of this equipment become completely familiar with possible safety hazards and that they establish effective operator instruction and use procedures together with routine safety procedures such as routine source-leak tests, the routine recording and evaluation of film badge data, the use of survey meters, etc., in connection with the operation of equipment of this type.

A1.7 The in-place nuclear density tests of this method offer several advantages over the older conventional methods (sand-cone, rubber-balloon, etc.), particularly in tests performed for the continuing control of construction. Among these, perhaps the principal advantage is the relative ease with which the test can be performed, thus freeing the operator from the physical tasks of digging holes and collecting and weighing bulky samples. However, it sacrifices the opportunity to examine the soil in depth. If information is sought on in-place densities only, and test determinations of maximum density are not involved, many more tests can be performed per day than by the older methods. In addition, apparently erratic measurements can be immediately detected and checked since the nuclear tests are more nearly nondestructive. These advantages accrue to organizations that are engaged in density measurements on a more or less continuous basis. Organizations that make infrequent or occasional density determinations may find that the advantages of the nuclear method can be offset by maintenance and start-up considerations such as periodically charging batteries, maintaining radiation exposure records, etc.

Standard Method of Test for
Moisture Content of Soil and Soil-Aggregate in
Place by Nuclear Methods (Shallow Depth)
WFLHD Designation: T 239-94 (Modified T 239)

INTRODUCTION

This method covers determination of the moisture content of soil and soil-aggregate in place through the use of nuclear equipment. The equipment is calibrated to determine moisture content, as mass of water per unit volume of material (kilograms per cubic meter or pounds per cubic foot). Moisture content as normally used is defined as the ratio, expressed as a percentage, of the mass of water in a given soil mass to the mass of solid particles. It is determined with this procedure by dividing the moisture content (kilograms per cubic meter or pounds per cubic foot) by the dry density of soil (kilograms per cubic meter or pounds per cubic foot or). Therefore, computation of moisture content using the nuclear equipment also requires the determination of the dry density of the material under test. Most available nuclear equipment has provision for measuring both moisture content (kilograms per cubic meter or pounds per cubic foot) and wet density. The difference between these two measurements gives dry density.

The moisture content determined by this method is not necessarily the average moisture within the volume of sample involved in the measurement for reasons discussed in the Appendix. The principles of this method as well as the advantages and limitations are also discussed in the Appendix.

The equipment utilizes radioactive materials which may be hazardous to the health of the users unless proper precautions are taken.

Before using any nuclear gages, the user shall first receive training in radiation safety and in the proper care and use of the nuclear equipment.

Due to rapid changes in nuclear gage technology, the methods and procedures described in this test standard are intentionally general in nature and may or may not be totally applicable to a given nuclear gage. Before operating a given model of nuclear gage, the user shall become thoroughly familiar with the manufacturer's operating manual for that gage, shall follow the procedures and recommendations of the manufacturer at all times and shall subscribe to procedures described hereafter as applicable.

1. SCOPE

1.1 This method covers determination of the moisture content of soil and soil-aggregate in place by moderation or slowing of fast neutrons where the neutron source and the thermal neutron detector both remain at the surface.

2. APPLICABLE DOCUMENTS

2.1 AASHTO Test Methods:

- T 191 Density of Soil in Place by the Sand-Cone Method
- T 205 Density of Soil in Place by the Rubber-Balloon Method
- T 265 Laboratory Determination of Moisture Content of Soil

3. SUMMARY OF METHOD

3.1 The moisture content of the material under test is determined by placing a fast neutron source and a thermal neutron detector on or adjacent to the material under test. The intensity of slow or moderated neutrons detected is dependent upon the moisture content of the material under test. Moisture is determined by the relationship of nuclear count to mass of water per unit volume of soil.

4. SIGNIFICANCE

4.1 The method described is useful as a rapid, nondestructive technique for the in-place determination of moisture content of soil and soil-aggregate. The fundamental assumptions inherent in the method are that the hydrogen present is in the form of water as defined by AASHTO T 265, and that the material under test is homogeneous.

4.2 The method is suitable for control and acceptance testing of soils and soil-aggregate for construction, research, and development. Test results may be affected by chemical composition, sample heterogeneity, and, to a lesser degree, material density and the surface texture of the material being tested. The technique also exhibits spatial bias in that the apparatus is more sensitive to certain regions of the material under test.

5. APPARATUS

5.1 **Fast Neutron Source** - A sealed isotope material such as americium-beryllium, radium-beryllium, or an electronic device such as a neutron generator.

5.2 **Slow Neutron Detector** - Any type of slow neutron detector such as boron trifluoride, a scintillator crystal, or a fission chamber.

5.3 **Readout Device** - A suitable scaler. Usually the readout device will contain the high-voltage supply necessary to operate the detector, and low-voltage power supply to operate the readout and accessory devices.

5.4 **Housing** - The source, detector, readout device, and power supply shall be in housings of rugged construction which shall be moisture-proof and dust-proof.

Note 1 - The neutron source, detector, readout device, and power supply may be housed separately or may be combined and integrated with a nuclear density measuring system.

5.5 Reference Standard - Reference standard, for checking equipment operation and background count, and to establish conditions for a reproducible count rate.

5.6 Site Preparation Device - A steel plate, straightedge, or other suitable leveling tools may be used to plane the test site to the required smoothness.

6. CALIBRATION

Section 6. deals with the calibration requirements of nuclear gages. This section is not normally applicable to field testing as the calibration checks on the equipment are usually made at the point of manufacture and/or at the central laboratory. This section has therefore been deliberately omitted from this test standard.

7. PROCEDURE

7.1 Standardization - Standardization of equipment on a reference standard is required at the start of each day's use as follows:

7.1.1 Warm up the equipment in accordance with the manufacturer's recommendations.

7.1.2 Take at least four repetitive readings of at least 1 min. each with the gage on the reference standard. This constitutes one standardization check.

7.1.3 If the mean of the four repetitive readings is outside the limits set by Eq 1, below, repeat the standardization check. If either the first or the second attempt satisfies Eq 1, the equipment is considered to be in satisfactory operating condition; continue with the procedure in 7.2. The empirical relationship for the standardization check is as follows:

$$N_s = N_o \pm 1.96 (N_o)^{1/2} \quad (1)$$

Where:

N_s = mean of repetitive readings (see 7.1.2) and
 N_o = previously established count for the reference standard (mean of ten repetitive readings).

7.1.4 If the second attempt in 7.1.3 does not satisfy Eq 1, check the system and repair the instrument if necessary. It is possible to use the instrument in this condition if a satisfactory calibration relationship can be established (contact the central laboratory for further guidance).

7.1.5 Establish a new N_o by computing the mean of ten repetitive readings on the reference standard.

7.1.6 Check the calibration curve in accordance with 6.2 and, if necessary, adjust the calibration curve in accordance with 6.3.

7.2 Test Site Preparation - Select a location for test where the gage in test position will be at least 150 mm (6 in.) away from any vertical projection.

7.2.1 Prepare the test site in the following manner:

7.2.1.1 Remove all loose and disturbed material, and remove additional material as necessary to reach the top of the vertical interval to be tested.

7.2.1.2 Prepare a horizontal area, sufficient in size to accommodate the gage, by planing to a smooth condition so as to obtain maximum contact between the gage and material being tested.

7.2.1.3 The maximum depressions beneath the gage shall not exceed 3 mm (1/8 in.). Use native fines or fine sand to fill voids and level the excess with a rigid plate or other suitable tool.

Note 4 - The spatial bias should be considered in determining the depth at which the gage is to be seated.

Note 5 - The placement of the gage on the surface of the material to be tested is critical to the successful determination of moisture. The optimum condition is total contact between the bottom surface of the gage and the surface of the material being tested. This is not practically possible in all cases and therefore it becomes necessary to use a sand filler or similar material. The depth of sand fill should not exceed 3 mm (1/8 in.) and the total area filled should not exceed 10 percent of the bottom area of the gage. Several trial seatings may be required to achieve these conditions.

7.3 Testing - Proceed with testing in the following manner:

7.3.1 Seat the gage firmly.

7.3.2 Keep all other radioactive sources away from the gage (as recommended by the manufacturer) so as not to affect the readings.

7.3.3 Use sufficient warm-up time as in standardization (7.1.1).

7.3.4 Place the source in the use position and take one or more 1 min. readings.

8. CALCULATIONS

8.1 Average the readings obtained in 7.3.4.

8.2 Determine the moisture content by use of an applicable calibration curve.

8.3 Calculate the moisture content, w , in mass percent of the dry soil as follows:

$$w = (W_m/W_d) \times 100 \quad (2)$$

Where:

W_m = moisture content of soil, kg/m^3 (lb/ft^3), and
 W_d = dry density of soil, kg/m^3 (lb/ft^3).

9. REPORT

9.1 The report shall include the following:

9.1.1 Location,

9.1.2 Elevation of surface,

9.1.3 Visual description of material,

9.1.4 Identification of test equipment (make, model and serial number),

9.1.5 Count rate for each reading,

9.1.6 Moisture content in kg/m^3 (lb/ft^3),

9.1.7 Wet density,

9.1.8 Dry density, and

9.1.9 Moisture content mass percent of dry soil.

10. PRECISION

Section 10. deals with the precision requirements of nuclear gages. This section is not normally applicable to field testing as the precision checks on the equipment are usually made at the point of manufacture and/or at the central laboratory. This section has therefore been deliberately omitted from this test standard.

APPENDIX

A1. NOTES ON THE NUCLEAR TEST

A1.1 The equipment used in this method is of the surface type as opposed to that designed for use in deep borings. In general, and neglecting the associated electronics, this equipment consists of three principal elements: (1) a suitable nuclear source emitting fast neutrons; (2) a detector sensitive to these neutrons after they are modified by passing through the material being tested; and (3) a counter, with provisions for automatic and precise timing, for determining the rate at which the modified neutrons arrive at the detector. While rate meters are suitable, in principle, counters are commonly used. In general any source of sufficiently numerous and properly energetic neutrons can be used in measuring the moisture content of soil and soil-aggregate. The sources most commonly used, however, are americium-beryllium and radium-beryllium with the latter normally being used in dual-purpose instruments that are designed to also determine wet or total density of soil and soil-aggregates. Detectors used are gas-filled tubes of boron trifluoride and scintillation crystals or fission chambers. Detectors of the latter type offer the potential of varying the range of energies of the neutrons that are counted.

A1.2 Measurements are made using fast neutrons that reflect modification by back-scattering through the material under test. When high-energy neutrons are scattered into the soil, a loss in velocity of each neutron occurs as it collides with the nuclei of the atoms of the soil. The rate at which this slowing down process occurs depends upon: (1) the mass of the nucleus in collision with the neutron, and (2) the probability that the two will collide.

A1.2.1 The mass of the hydrogen nucleus is nearly equal to the neutron mass. Collision with hydrogen atoms therefore, reduces the velocity of neutrons more quickly than collision with heavier nuclei. The large difference between the masses of hydrogen atoms and those normally encountered in soils means that the relative effectiveness of hydrogen atoms in slowing down neutrons is very pronounced.

A1.2.2 The probability that a neutron will collide with the nucleus of an atom is dependent on the atom's scattering cross section. For most elements, this value is low, usually increasing with decrease in neutron energy. The scattering cross section of the hydrogen atom for high energy neutrons, however, is larger than for most of the other atoms present in soils.

A1.2.3 These two features in combination make hydrogen the most effective medium for reducing the velocity of fast neutrons. If a detector of thermal (slow) neutrons is placed near a neutron source in a soil containing hydrogen, the activity registered is due almost entirely to neutrons that have been slowed down by hydrogen atoms. Other atoms present in the soil play a negligible part in this process. In natural soils hydrogen may be present in several forms but, with some exceptions, it occurs principally in the water held by the soil particles. Therefore, the "slow neutron" activity registered by a suitable detector can be related to the concentration of water in a soil by calibration.

A1.3 The determination of moisture content by the nuclear means of this method is indirect. To date no theoretical approach has been developed that predicts the count rate for given equipment, geometry, material, density, and

moisture content. As a result the relation between soil moisture and nuclear-count rate is determined by correlation tests of materials at known moisture content. Individual equipment manufacturers supply a calibration curve with each set of their equipment. It has been found that these curves do not necessarily hold for all soils and soil-aggregates because of differences in chemical composition. Apparent variations in calibration curves may also be induced by differences in seating, in background count, and other test variations. Because of these considerations, provisions are included in this method for checking for variations or changes. Different approaches may be used in checking calibration curves and those in more general use are given. For good practice these should be followed with newly purchased equipment and with major component replacement of in-service equipment.

A1.4 The moisture content determined by this method is the amount of moisture that is contained in a given volume of soil. It should be noted that the volume of soil and soil-aggregate represented in the measurement is indeterminate and will vary with the source-detector geometry of the equipment used and with the characteristics of the material tested. In general, and with all other conditions constant, the greater the moisture content of the material, the smaller the volume involved in the measurement. Unlike oven drying tests, the moisture content so determined is not necessarily the average moisture within the volume involved in the measurement. For the usual surface test equipment and materials, for example, about 50 percent of the measured count rate is determined by the upper 75 to 100 mm (3 to 4 in.) of soils and soil-aggregate.

A1.5 The number of fast neutrons emitted from a given source over a given time period are statistically random and follow a Gaussian distribution. Because of this, the actual number of modified neutrons that are detected and counted in the moisture measuring process should be sufficiently large to minimize the probability that the observed count reflects unacceptable variations. This is reflected in the standard deviation which is the square root of the total count. The over-all system accuracy in determining moisture is also statistical in nature and appears to vary with equipment used, test conditions of laboratory versus field, materials, and operators. Because of these variables it is not possible to give precise numbers for system accuracy and precision for these test methods. It is believed, however, that if the procedures herein are carefully followed, the standard deviation of the nuclear measured values, in terms of accuracy, will not be greater than on the order of some 8 to 16 kg/m³ (0.5 to 1.0 lb/ft³). Precision, determined without moving the test equipment, should be better than 5 kg/m³ (0.3 lb/ft³).

A1.6 One of the fast neutron sources used, americium, is man-made and as such its use is regulated by the Federal Government through the Atomic Energy Commission as well as by some state and local governments. Because radium and beryllium are naturally occurring material, their use is not now regulated by the Federal Government but is regulated by some state and local governments. Among others, the objectives of these regulations are the use of radioactive materials in a manner safe to the operator and all others.

A1.7 The in-place nuclear moisture tests of this method offer several advantages over conventional methods, such as oven drying of samples, particularly in tests performed for the continuing control of construction. Its greatest advantage is perhaps the short time required to obtain a moisture content. An answer is available on the spot in a manner of minutes after

completing the test. When conducting both moisture and density tests, many more tests per day can be conducted than by older methods in current use. In addition, apparently erratic measurements can be immediately detected and checked since the nuclear tests are more nearly nondestructive. These advantages accrue to organizations that are engaged in moisture measurements on a more or less continuous basis. Organizations that make infrequent or occasional moisture determinations may find that the advantages of the nuclear methods can be offset by maintenance and start up considerations such as periodically charging batteries, maintaining radiation exposure records, etc.

Standard Methods for

Reducing Field Samples of Aggregate to Testing Size WFLHD Designation: T 248-94 (Modified AASHTO T 248)

1. SCOPE

1.1 These methods cover the reduction of field samples of aggregate to the appropriate size for testing employing techniques that are intended to minimize variations in measured characteristics between the test samples so selected and the field sample.

Note 1 - Under certain circumstances, reduction in size of the field sample prior to testing is not recommended. Substantial differences between the selected test samples sometimes cannot be avoided, as for example, in the case of an aggregate having relatively few large size particles in the field sample. The laws of chance dictate that these few particles may be unequally distributed among the reduced size test samples. Similarly, if the test sample is being examined for certain contaminants occurring as a few discrete fragments in only small percentages, caution should be used in interpreting results from the reduced size test sample. Chance inclusion or exclusion of only one or two particles in the selected sample may importantly influence interpretation of the characteristics of the field sample. In these cases, the entire field sample should be tested.

2. SELECTION OF METHOD

2.1 **Fine Aggregates** - Field samples of fine aggregate that are drier than the saturated-surface-dry condition shall be reduced in size by a mechanical splitter according to Method A. Field samples having free moisture on the particle surfaces may be reduced in size by quartering according to Method B, or the entire field sample may be dried to at least the surface-dry condition, using temperatures that do not exceed those specified for any of the tests contemplated, and then reduced to test sample size using Method A.

2.1.1 Field samples of fine aggregate having free moisture on particle surfaces may be reduced to testing size by treatment as a miniature stockpile as described in Method C.

2.1.2 If a moist field sample is very large, a preliminary split may be made using a mechanical splitter having wide chute openings 37.5 mm (1-1/2 in.) or more to reduce the sample to not less than 5000 g, the portion so obtained is then dried, and reduction to test sample size is completed using Method A.

Note 2 - The method of determining the saturated-surface-dry condition is described in AASHTO T 84. As a quick approximation, if the fine aggregate will retain its shape when molded in the hand, it may be considered to be wetter than saturated-surface-dry.

2.2 **Coarse Aggregate** - Use of a mechanical splitter in accordance with Method A is preferred; otherwise the field sample shall be reduced by quartering in accordance with Method B.

3. FIELD SAMPLE SIZE

3.1 When gradation tests only are contemplated, the size of the field sample shall conform to the requirements of AASHTO T 2. When additional tests are to be conducted, the user shall satisfy himself that the initial size of the field sample is adequate to accomplish all intended tests.

METHOD A - MECHANICAL SPLITTER

4. APPARATUS

4.1 **Sample Splitter** - Sample splitters shall have an even number of equal width chutes, but not less than a total of eight for coarse aggregate, or twelve for fine aggregate, which discharge alternately to each side of the splitter. The minimum width of the individual chutes shall be approximately 50 percent larger than the largest particles in the sample to be split. The splitter shall be equipped with two receptacles to hold the two halves of the sample following splitting. It shall also be equipped with a hopper or straightedged pan which has a width equal to or slightly less than the over-all width of the assembly of chutes, by which the sample may be fed at a controlled rate to the chutes. The splitter and accessory equipment shall be so designed that the sample will flow smoothly without restriction or loss of material (Fig. 1).

Note 3 - Mechanical splitters are commonly available in sizes adequate for coarse aggregate having the largest particle not over 37.5 mm (1-1/2 in.). For fine aggregate, a splitter having chutes 12.5 mm (1/2 in.) wide will be satisfactory when the entire sample will pass a 9.5 mm (3/8 in.) sieve.

Note 4 - Mechanical splitters shall not be used for reducing samples of asphaltic mixtures.

5. PROCEDURE

5.1 Place the field sample in the hopper or pan and uniformly distribute it from edge to edge, so that when it is introduced into the chutes, approximately equal amounts will flow through each chute. The rate at which the sample is introduced shall be such as to allow free flowing through the chutes into the receptacles below. Reintroduce the portion of the sample in one of the receptacles into the splitter as many times as necessary to reduce the sample to the size specified for the intended test. The portion of the material collected in the other receptacle may be reserved for reduction in size for other tests.

METHOD B - QUARTERING

6. APPARATUS

6.1 Apparatus shall consist of a straightedge scoop, shovel, or trowel; a broom or brush; and a blanket made of canvas or other suitable material approximately 2 by 2.5 m (6 by 8 ft).

7. PROCEDURE

7.1 Use either the procedure described in 7.1.1. or 7.1.2 or a combination of both.

7.1.1 Place the field sample on a hard, clean, level surface where there will be neither loss of material nor the accidental addition of foreign material. Mix the material thoroughly by turning the entire sample over three times. With the last turning, shovel the entire sample into a conical pile by depositing each shovelful on top of the preceding one. Carefully flatten the conical pile to a uniform thickness and diameter by pressing down the apex with a shovel so that each quarter sector of the resulting pile will contain the material originally in it. The diameter should be approximately four to eight times the thickness. Divide the flattened mass into four equal quarters with a shovel or trowel and remove two diagonally opposite quarters, including all fine material, and brush the cleared spaces clean. Successively mix and quarter the remaining material until the sample is reduced to the desired size (Fig. 2).

7.1.2 As an alternative to the procedure described in 7.1.1 when the the floor surface is uneven, the field sample may be placed on a canvas blanket and mixed with a shovel as described in 7.1.1, or by alternately lifting each corner of the canvas and pulling it over the sample toward the diagonally opposite corner causing the material to be rolled. Flatten the pile as described in 7.1.1. Divide the sample as described in 7.1.1 or if the surface beneath the blanket is uneven, insert a stick or pipe beneath the blanket and under the center of the pile, then lift both ends of the stick, dividing the sample into two equal parts. Remove the stick leaving a fold of the blanket between the divided portions. Insert the stick under the center of the pile at right angles to the first division and again lift both ends of the stick, dividing the sample into four equal parts. Remove two diagonally opposite quarters, being careful to clean the fines from the blanket. Successively mix and quarter the remaining material until the sample is reduced to the desired size (Fig. 3).

METHOD C - MINIATURE STOCKPILE SAMPLING

8. APPARATUS

8.1 Apparatus shall consist of either a small sampling thief, small scoop or spoon of appropriate size for the size of test sample being obtained.

9. PROCEDURE

9.1 Place the entire field sample (meeting the minimum size requirements for the material being reduced) on a hard, clean, level, non-absorbent surface. Thoroughly mix the sample and spread the material out so as to form a miniature stockpile not exceeding 75 mm (3 in.) in depth and having a diameter to height ratio of approximately 5:1. Obtain sample for each test by selecting a minimum of five increments and a maximum of eight increments of material at random locations from the miniature stockpile, using any of the devices described in 8.1.

METHOD D - PAN SPLITTING

10. APPARATUS

10.1 Apparatus shall consist of a minimum of three square or rectangular pans having a depth of at least 38 mm (1-1/2 in.).

11. PROCEDURE

11.1 Thoroughly mix the sample to be split and place in a pan to a uniform depth. Place two empty pans side by side and dump the contents of the third pan over the two empty pans so that approximately equal portions are obtained in each of the two pans. Repeat this procedure as many times as necessary to obtain a sample of the appropriate size for testing.

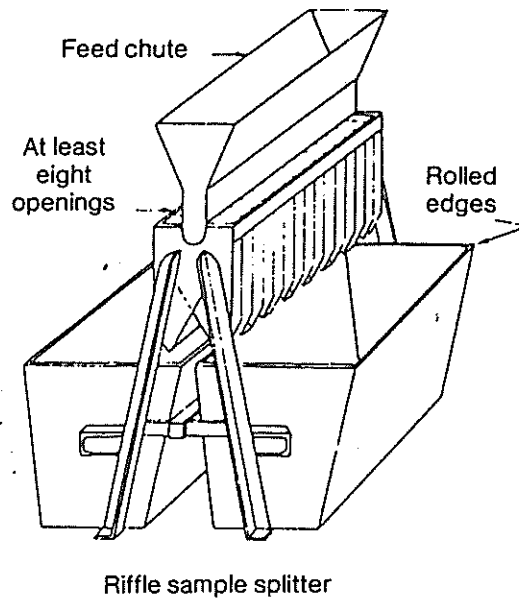

(a) Large riffle samplers for coarse aggregate.

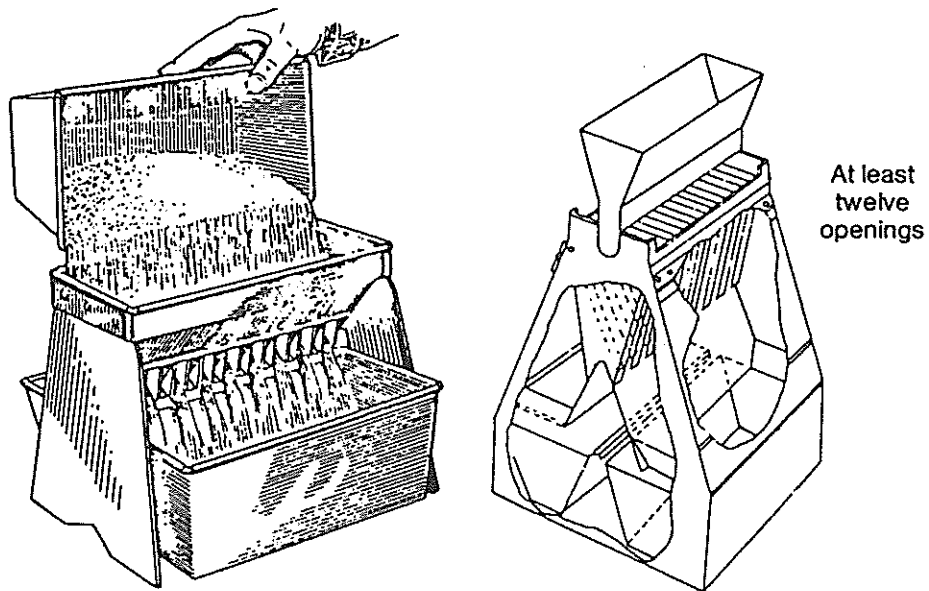

NOTE—May be constructed as either closed or open type. Closed type is preferred.

(b) Small riffle sampler for fine aggregate

Fig. 1. Sample Splitters

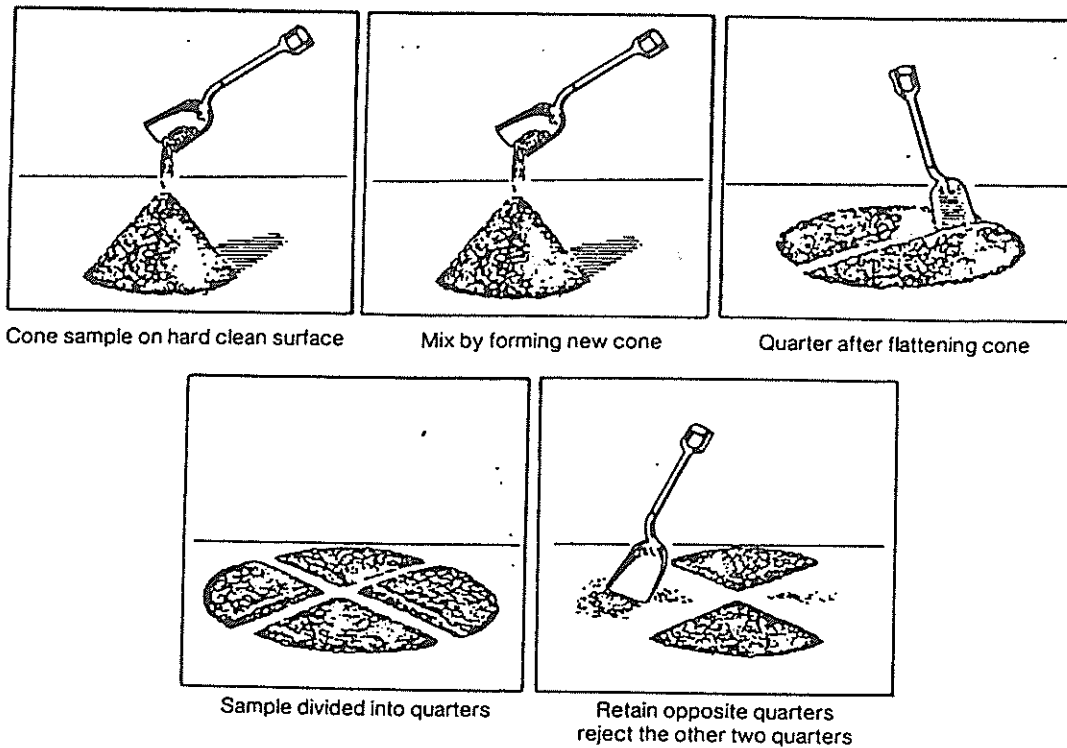

Fig. 2. Quartering on a Hard, Clean, Level Surface

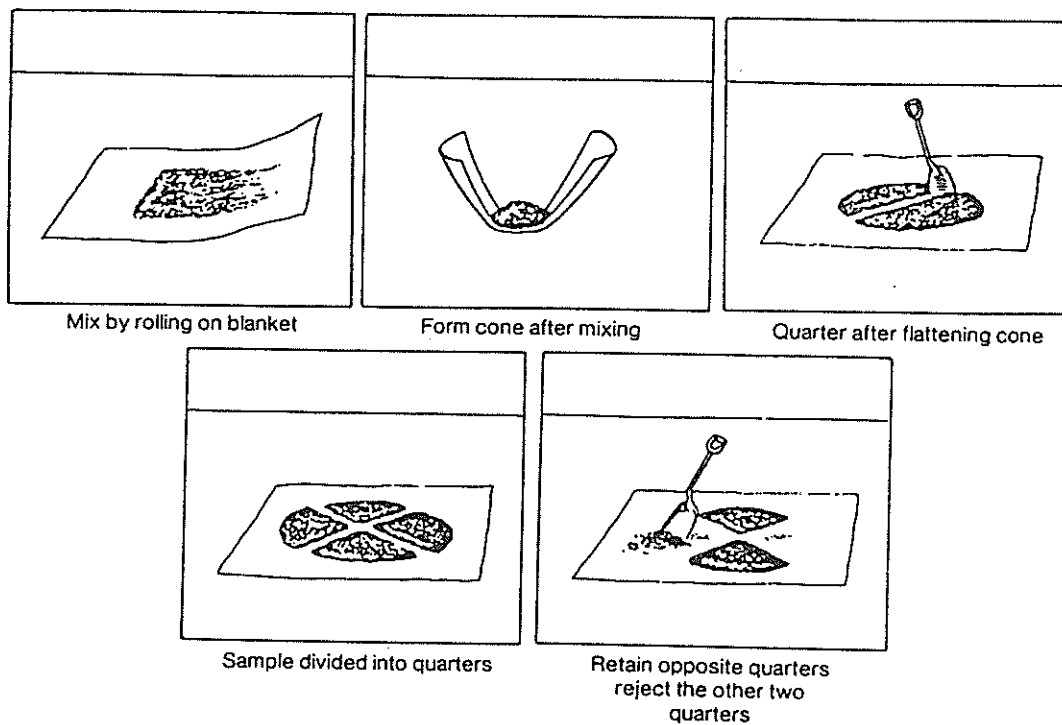

Fig. 3. Quartering on a Canvas Blanket

Standard Method of Test for

Total Moisture Content of Aggregate by Drying WFLHD Designation: T 255-94 (Modified AASHTO T 255)

1. SCOPE

1.1 This method covers the determination of the percentage of evaporable moisture in a sample of aggregate by drying.

1.2 This method may also be used to determine whether high drying temperatures affect sieve analysis. If the operator determines by comparison that high drying temperatures do not cause breakdown of particle size sufficient to affect acceptance of the aggregates, high drying temperatures may be used for sieve analysis.

2. APPLICABLE DOCUMENTS

2.1 AASHTO Standards:

T 2 Sampling Aggregates

T 27 Sieve Analysis of Fine and Coarse Aggregate

T 84 Specific Gravity and Absorption of Fine Aggregate

T 85 Specific Gravity and Absorption of Coarse Aggregate

3. SIGNIFICANCE AND USE

3.1 This method is sufficiently accurate for usual purposes such as adjusting batch weights of concrete. It will generally measure the moisture in the test sample more reliably than the sample can be made to represent the aggregate supply. In rare cases where the aggregate itself is altered by heat, or where more refined measurement is required, the test may not be applicable or will require modification.

4. APPARATUS

4.1 Balance - The balance shall conform to the requirements of AASHTO M 231 for the class of general purpose balance required for the principal sample weight of the sample being tested.

4.2 Source of Heat - A suitable source of heat such as an electric or gas hot plate, electric heat lamps, or a ventilated oven capable of maintaining the temperature surrounding the sample at 110 ± 5 C (230 ± 9 F).

4.3 Sample Container - A metal container not affected by the heat, and of sufficient volume to contain the sample without danger of spilling, and of such shape that the depth of sample will not exceed one fifth of the least lateral dimension.

Note 1 - Except for testing large samples, an ordinary frying pan is suitable for use with a hot plate, or any shallow flat-bottomed metal pan with heat lamps or oven.

4.4 **Stirrer** - A metal spoon or spatula of convenient size.

4.5 **Sieves** - Woven wire cloth sieves conforming to AASHTO M 92.

5. **SAMPLING**

5.1 Sampling shall generally be accomplished in accordance with AASHTO T 2.

6. **SAMPLE**

6.1 Secure a sample of the aggregate representative of the moisture content in the supply being tested and, in the case of normal-weight aggregate, weighing not less than the amount listed in Table 1.

7. **PROCEDURE**

7.1 Weigh the sample to the nearest 0.1 percent, avoiding the loss of moisture to the extent possible.

7.2 Dry the sample thoroughly in the sample container by means of the selected source of heat, exercising care to avoid loss of any particles. If a source of heat other than the controlled temperature oven is used, stir the sample during drying to accelerate the operation and avoid localized overheating. The sample is thoroughly dry when further heating causes, or would cause, less than 0.1 percent additional loss in weight.

7.3 Weigh the dried sample to the nearest 0.1 percent after it has cooled sufficiently not to damage the balance.

7.4 To determine whether high drying temperatures affect sieve analysis results, obtain a sample with a minimum mass of double that indicated in Table 1. Split the moist sample in accordance with AASHTO T 248. Dry one split at a maximum temperature of 110 C (230 F) and dry the other split at a minimum temperature of 205 C (400 F).

7.5 In accordance with AASHTO T 27, sieve the dried sample splits through nested sieves of the appropriate size for the material being tested and compare the results. If there is no appreciable difference in the results, then higher drying temperatures [greater than 110 C (230 F)] may be used for drying samples used for sieve analysis.

Note 2 - Infrared heaters should be set up in an area free of drafts. This will enable the operator to obtain temperatures from 110 C to 315 C (230 F to approximately 600 F) by raising or lowering the heating unit on the adjustable frame. If it is impractical to set the heater in a draft-free area, skirting the heater with tin or other non-flammable material will prove satisfactory.

Note 3 - When drying the aggregate, the use of a large pan or pans is recommended. This will enable the operator to spread the sample in a thin lift; also repeated stirring will speed the drying.

Note 4 - Using an 5 to 7 kg (11 to 15 lb.) sample and drying at 205 C (400 F) plus, the sample will dry in one hour or less in most cases. A 500 to 700 g sample of 4.75 mm minus material dries in approximately 20 minutes.

Note 5 - When using microwave ovens, try various power settings to determine the highest setting which can be used without causing the aggregate to break down. If breakdown occurs at all continuous power settings, try using the pulsed power setting (Defrost/Reheat).

Table 1
Sample Size for Normal Weight Aggregate

Nominal Size mm	Size Max ^a (in.)	Mass of Sample min. kg ^b
6.3	(1/4)(sand)	0.5
9.5	(3/8)	1.5
12.5	(1/2)	2
19.0	(3/4)	3
25.0	(1)	4
37.5	(1-1/2)	6
50	(2)	8
63	(2-1/2)	10
75	(3)	13
90	(3-1/2)	16
100	(4)	25
150	(6)	50

a Size of sieve upon which less than 10 percent will be retained

b To determine the minimum sample weight for lightweight aggregate, multiply the value by the approximate dry loose density (unit weight) of the aggregate in kg/m³ and divide by 1600.

8. CALCULATION

8.1 Calculate total moisture content as follows:

$$p = 100(W - D)/D$$

Where:

p = moisture content of sample, percent,

W = mass of original sample, g, and

D = mass of dried sample, g.

8.2 Surface moisture content is equal to the difference between the total moisture content and the absorption. Absorption may be determined in accordance with AASHTO T 85, Test for Specific Gravity and Absorption of Coarse Aggregate, or AASHTO T 84, Test for Specific Gravity and Absorption of Fine Aggregate.

9. PRECISION AND ACCURACY

9.1 Data are not available to develop a statement of precision and accuracy. Since any size of sample above the minimum quantities given in Table 1 are permitted, it is believed that a meaningful statement is not possible.

9.2 For each particular application of this test method an indication of the precision associated with the actual sample sizes and equipment utilized can be developed by: (1) running tests on duplicate test portions taken from the same sample or (2) taking duplicate samples representing the same lot of aggregate. Data on accuracy of the procedures used might also be developed by adding a known quantity of water to a dry aggregate taking care that no water is lost prior to testing.

Standard Method of Test for

Laboratory Determination of Moisture Content of Soils WFLHD Designation: T 265-94 (Modified AASHTO T 265)

1. SCOPE

1.1 This method covers the laboratory determination of the moisture content of soil.

2. DEFINITION

2.1 **Moisture or Water Content of a Soil** - The ratio, expressed as a percentage, of the weight of water in a given mass of soil to the weight of the solid particles. Practical application is to determine the weight of water removed by drying the moist soil to a constant weight in a drying oven controlled at 110 ± 5 C (230 ± 9 F) and to use this value as the weight of water in the given soil mass. The weight of soil remaining after oven drying is used as the weight of the solid particles.

3. APPARATUS

3.1 **Drying Oven** - Thermostatically controlled, preferably of the forced draft type, capable of being heated continuously at a temperature of 110 ± 5 C (230 ± 9 F).

3.2 **Balance** - The balance shall conform to the requirements of AASHTO M 231, for the class of general purpose balance required for the principal sample weight of the sample being prepared.

3.3 **Containers** - Suitable containers made of material resistant to corrosion and not subject to change in weight or disintegration on repeated heating and cooling. Containers shall have close fitting lids to prevent loss of moisture from samples before initial weighing and to prevent absorption of moisture from the atmosphere following drying and before final weighing. One container is needed for each moisture content determination.

4. TEST SAMPLE

4.1 Select a representative quantity of moist soil in the amount indicated in the method of test. If no amount is indicated, the minimum weight of the sample shall be in accordance with the following table:

<u>Maximum Particle Size</u>	<u>Minimum Weight of Sample, g</u>
425 μ m (No. 40)	10
4.75 mm (No. 4)	100
12.5 mm (1/2 in.)	300
25 mm (1 in.)	500
50 mm (2 in.)	1000

5. PROCEDURE

5.1 Weigh a clean, dry container with its lid, and place the moisture content sample in the container. Replace the lid immediately, and weigh the container, including the lid and the moist sample. Remove the lid and place the container with the moist sample in the drying oven maintained at a temperature of 110 ± 5 C (230 ± 9 F) and dry to a constant weight. Immediately upon removal from the oven, place the lid and allow the sample to cool to room temperature. Weigh the container including the lid and the dried sample.

Note 1 - Checking every moisture content sample to determine that it is dried to a constant weight is impractical. In most cases, drying of a moisture content sample overnight (15 or 16 h) is sufficient. In cases where there is doubt concerning the adequacy of overnight drying or results are required in less time, drying should be continued until the weights after two successive periods (30 min. minimum between weighings) of drying indicate no change in weight. Samples of sand may often be dried to constant weight in a period of several hours. Since dry soil may absorb moisture from wet samples, dried samples should be removed before placing wet samples in the oven.

Note 2 - Oven drying at 110 ± 5 C (230 ± 9 F) does not result in reliable moisture content values for soil containing gypsum or other minerals having loosely bound water of hydration or for soil containing significant amounts of organic material. Reliable moisture content values for these soils can be obtained by drying in an oven at approximately 60 C (140 F), or by vacuum desiccation at a pressure of approximately 10 mm Hg and at a temperature not lower than 23 C (73 F).

Note 3 - A container without a lid may be used provided the moist sample is weighed immediately after being taken and providing the dried sample is weighed immediately after being removed from the oven or after cooling in a desiccator.

Note 4 - Moisture content samples should be discarded and should not be used in any other tests.

6. CALCULATION

6.1 Calculate the moisture content of the soil as follows:

$$w = \frac{\text{[(weight of moisture)]}}{\text{[(weight of oven dry soil)]}} \times 100$$

$$w = \frac{[(W_1 - W_2)]}{[(W_2 - W_c)]} \times 100$$

Where:

w = moisture content, %

W_1 = weight of container and moist soil, g

W_2 = weight of container and oven dried soil, g, and

W_c = weight of container, g