

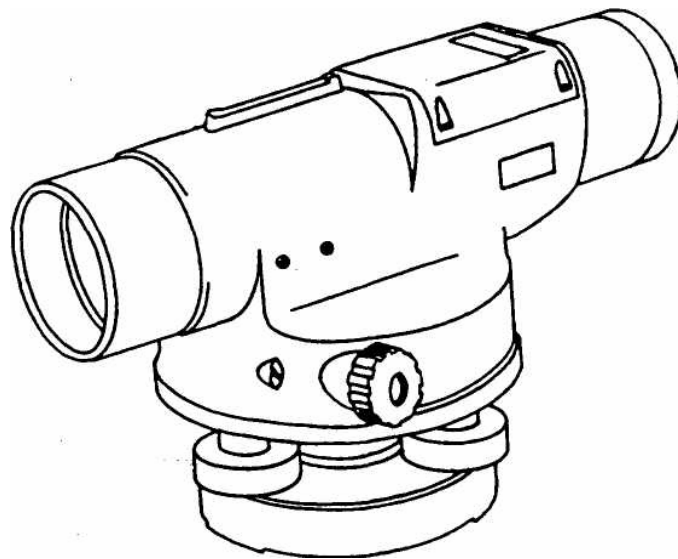

**US Army Corps
of Engineers**
Hydrologic Engineering Center

Accuracy of Computed Water Surface Profiles

Commercial Survey Guidelines for Water Surface Profiles - Supplement



January 1987

REPORT DOCUMENTATION PAGE

Form Approved OMB No. 0704-0188

The public reporting burden for this collection of information is estimated to average 1 hour per response, including the time for reviewing instructions, searching existing data sources, gathering and maintaining the data needed, and completing and reviewing the collection of information. Send comments regarding this burden estimate or any other aspect of this collection of information, including suggestions for reducing this burden, to the Department of Defense, Executive Services and Communications Directorate (0704-0188). Respondents should be aware that notwithstanding any other provision of law, no person shall be subject to any penalty for failing to comply with a collection of information if it does not display a currently valid OMB control number.

PLEASE DO NOT RETURN YOUR FORM TO THE ABOVE ORGANIZATION.

1. REPORT DATE (DD-MM-YYYY) January 1987		2. REPORT TYPE Research Document		3. DATES COVERED (From - To)	
4. TITLE AND SUBTITLE Accuracy of Computed Water Surface Profiles Commercial Survey Guidelines for Water Surface Profiles - Supplement				5a. CONTRACT NUMBER	
				5b. GRANT NUMBER	
				5c. PROGRAM ELEMENT NUMBER	
				5d. PROJECT NUMBER	
				5e. TASK NUMBER	
				5f. WORK UNIT NUMBER	
6. AUTHOR(S) CEIWR-HEC					
7. PERFORMING ORGANIZATION NAME(S) AND ADDRESS(ES) US Army Corps of Engineers Institute for Water Resources Hydrologic Engineering Center (HEC) 609 Second Street Davis, CA 95616-4687				8. PERFORMING ORGANIZATION REPORT NUMBER RD-26A	
9. SPONSORING/MONITORING AGENCY NAME(S) AND ADDRESS(ES)				10. SPONSOR/ MONITOR'S ACRONYM(S)	
				11. SPONSOR/ MONITOR'S REPORT NUMBER(S)	
12. DISTRIBUTION / AVAILABILITY STATEMENT Approved for public release; distribution is unlimited.					
13. SUPPLEMENTARY NOTES					
14. ABSTRACT The Commercial Survey Guidelines for Water Surface Profiles report is a supplement to a report entitled Accuracy of Computed Water Surface Profiles (RD-26). The document describes survey procedures for obtaining floodplain cross-sectional data used for computing water surface profiles. The procedures include: field survey, aerial spot elevation surveys, topographic maps, and hydrographic surveys. The accuracy and costs of the various methods are also presented.					
15. SUBJECT TERMS water surface profiles, cross sections, survey accuracy, field surveys, aerial spot elevation surveys, topographic maps, hydro-graphic surveys, cost estimates					
16. SECURITY CLASSIFICATION OF:			17. LIMITATION OF ABSTRACT	18. NUMBER OF PAGES	19a. NAME OF RESPONSIBLE PERSON
a. REPORT U	b. ABSTRACT U	c. THIS PAGE U			

Accuracy of Computed Water Surface Profiles

Commercial Survey Guidelines for Water
Surface Profiles - Supplement

January 1987

Prepared for:
Federal Highway Administration

Prepared by:
US Army Corps of Engineers
Institute for Water Resources
Hydrologic Engineering Center
609 Second Street
Davis, CA 95616

(530) 756-1104
(530) 756-8250 FAX
www.hec.usace.army.mil

RD-26A

TABLE OF CONTENTS

	<u>PAGE</u>
PREFACE.....	vi
SUMMARY OF FINDINGS	vii
INTRODUCTION	1
Purpose	1
Equipment and Procedures	1
General Overview	2
Report Contents	4
FIELD SURVEYS	7
General	7
Hand Levels	9
Conventional Levels	9
Electronic Distance Meters	9
Stadia and the Plane Table	10
Accuracy of Field Surveys	11
HYDROGRAPHIC SURVEYS	15
General	15
Accuracy	19
AERIAL SURVEYS	20
General	20
Concepts and Techniques	21
Preflight Planning	21
Horizontal and Vertical Ground Control	24
Flights	24
Analytical Bridging	24
Photogrammetric Work	25
Field Survey Checks	25
Final Products	25
Latest Equipment	25
Accuracy	26
EMERGING TECHNOLOGIES	28
Introduction	28
Aerial Surveys	28
Hydrographic Surveys	32
Automated Data Systems Technology	32
Summary Statement	33

TABLE OF CONTENTS
(Continued)

	<u>PAGE</u>
TOPOGRAPHIC AND CROSS-SECTION DATA AND COSTS	34
General	34
Available Data	34
USGS Quadrangle Maps	34
Federal and Local Agency Data	35
Commercial Sources of Data	36
Contracting Considerations	36
Associated Costs	37
Field Surveys	38
Aerial Surveys	42
Cost Curves	44
Example Comparisons	53
Survey Selection Considerations	55
Other Project Field Data Needs	55
Available Data	55
Project Size	56
Location of the Project	56
Time Schedule	56
Available Staff	56
Required Accuracy	57
Terrain and Vegetative Cover	57
Alternative Costs	57
REFERENCES	59

LIST OF TABLES

<u>No.</u>	<u>Title</u>	
1	Survey Equipment Procedure Accuracy, Horizontal Angles	12
2	Survey Equipment Procedure Accuracy, Horizontal Distance	13
3	Survey Equipment Procedure Accuracy, Vertical	14
4	Photogrammetry Map Planning Chart	22
5	Accuracy of Maps	27
6	Factors Affecting Survey Selection	58

TABLE OF CONTENTS
(Continued)

<u>No.</u>	<u>Title</u>	<u>PAGE</u>
1	Schematic of Survey Procedures	3
2	Schematic - Cross-Section Data Requirements	5
3	Sample - Cross-Section Survey - Horizontal and Vertical Control ...	8
4	Hydrographic Surveys - Platform Positioning	18
5	Illustration - Determination of Flying Height	23
6	Schematic - Emerging Technologies	29
7	Schematic - Aerial Distance Measuring Device	31
8	Schematic - Typical Section and Reach	39
9	Field and Aerial Surveys - Cost Information - Flat, Light-Cover Case	45
10	Field and Aerial Surveys - Cost Information - Cross Sections Only Flat, Light-Cover Case	46
11	Field and Aerial Surveys - Cost Per Section - Flat, Light-Cover Case	47
12	Field and Aerial Surveys - Cost Information - Steep, Heavy-Cover Case	48
13	Field and Aerial Surveys - Cost Information - Cross Sections Only Steep, Heavy-Cover Case	49
14	Field and Aerial Surveys - Cost Per Section - Steep, Heavy-Cover Case	50
15	Hydrographic Surveys - Cost Information	51
16	Hydrographic Surveys - Cost Per Section	52

TABLE OF CONTENTS
(Continued)

APPENDICES

A	Glossary of Terms Used in Aerial Photograph	Attached
B	Technical and Specification Requirements	"
C	Quantity and Cost Estimate Tables	"
D	Geographical Labor Differences	"

PREFACE

This document, entitled Commercial Survey Guidelines for Water Surface Profiles, is a supplement to the Accuracy of Computed Water Surface Profile report prepared by the Hydrologic Engineering Center, U.S. Army Corps of Engineers for the Federal Highway Administration, Department of Transportation dated December 1986. The material documented herein was used in the research study as background information on survey methods, accuracy, and costs.

The preparation of this report was done under contract with the Hydrologic Engineering Center (HEC), U.S. Army Corps of Engineers. Borcalli Ensign & Buckley was responsible for preparation of this report and was assisted by American Aerial Surveys, Inc. of Northern California and Yolo Engineers & Surveyors Inc. HEC staff members, Mr. Darryl Davis, Chief, Planning Analysis Branch and Mr. Michael Burnham, Project Manager provided guidance and information throughout the study period. Mr. Bill S. Eichert was Director of the HEC during the conduct of this study. Mr. John Buckley was Program Manager for Borcalli Ensign & Buckley. Mr. Howard Plumm from American Aerial Surveys, Inc. of Northern California and Mr. Bruce Tronoff from Yolo Engineers & Surveyors Inc., provided valuable descriptive and cost information for their respective fields. Mr. Joe Mori, Chief, Office of Geometronics, Photogrammetry Branch, California Department of Transportation, assisted in the review and editing of this report. His comments and suggested changes were very much appreciated.

SUMMARY OF FINDINGS

Based upon the investigations presented herein, the following statements summarize the findings of this report.

1. Commercially available aerial and field surveys utilize up-to-date equipment and procedures to develop topographic and cross-section data.
2. The equipment used to perform aerial and field surveys continues to improve due to emerging technology.
3. There are many potential sources of topographic and cross-section data that should be investigated before setting up a field data collection program.
4. Other project data needs may affect or even dictate the survey method to be used for a specific project.
5. When more than 10 to 15 cross sections are required, it is likely that aerial surveys will be more economical than field surveys.
6. The incremental costs to procure topographic mapping, in addition to cross-section data, can be quite economical considering the value of the mapping provided.

INTRODUCTION

PURPOSE

The purpose of this report is to provide information to highway engineers and others involved in selecting the appropriate method of data collection required for development of water surface profiles. Commercially available field and aerial surveys and procedures intended to provide cross-section data and topographic mapping are described. Accuracies of the survey procedures and generalized cost information to produce topographic mapping and cross sections, by both field and aerial surveys, are also presented. The information in this report is keyed to existing commercially available survey equipment and procedures; however, a brief section on emerging technologies is also included.

EQUIPMENT AND PROCEDURES

Commercially available field and aerial survey equipment and procedures are a result of many years of improvements. Thompson⁽¹⁾ noted the following:

"For its first topographic surveys, begun in 1879, USGS measured distances by counting revolutions of a wheel, ran traverses by chain and compass, and used a barometer to determine elevations. Between 1886 and 1908, inventions including the telescopic alidade led to improved plane-table surveying and mapping to increase speed and accuracy. Beginning in 1934, the mapping of the entire Tennessee River basin using aerial photography led to the gradual replacement of plane-table mapping in the field by photogrammetric mapping in the office."

Electronic Distance Meters (EDM) are commonly used by surveyors. These instruments employ laser light to measure distance with high relative accuracy. Cross-section data can be stored on EDM cassette tapes for transfer to an office plotter. The most up-to-date aerial photography

system ties the stereo equipment to a data storage system, digital plotting equipment, and a printer for data listing.

GENERAL OVERVIEW

In order to provide cross sections and topographic data, the extent of the project and the desired accuracy, map scales, and the form of the final data must be defined. The schematic on Figure 1 provides an overview of the steps required to provide aerial, field, or hydrographic survey information.

There are many references that document the concepts and theoretical basis for the hydraulic calculations performed to develop water surface profiles. The HEC-2 Water Surface Profiles computer program⁽²⁾ was developed based on these basic concepts and hydraulic theories and this program is widely used today. The HEC-2 Users Manual documents the basis for the calculations and outlines the data required to perform the water surface analysis.

When determining the field data required to perform water surface profile calculations there are a few basic questions that should be considered concerning cross-section information. These are:

- How wide do the cross sections have to be?
- How many cross sections are needed?
- How many points are required to define a cross section?
- Are there any existing bridges located within or near the reach being evaluated?

A good starting point to answer some of these questions is to plot a profile along the reach being considered using USGS quadrangle topographic maps or other available topographic maps. Locate known high water marks of rare events or of events of similar magnitude as the event of interest. Plot the high-water mark profiles of these events. If high water marks are not available, then an average section can be used with an estimated roughness coefficient and Mannings equation⁽³⁾ to evaluate approximate flood stages (normal depth estimate) along the study reach. Using the approximate stages

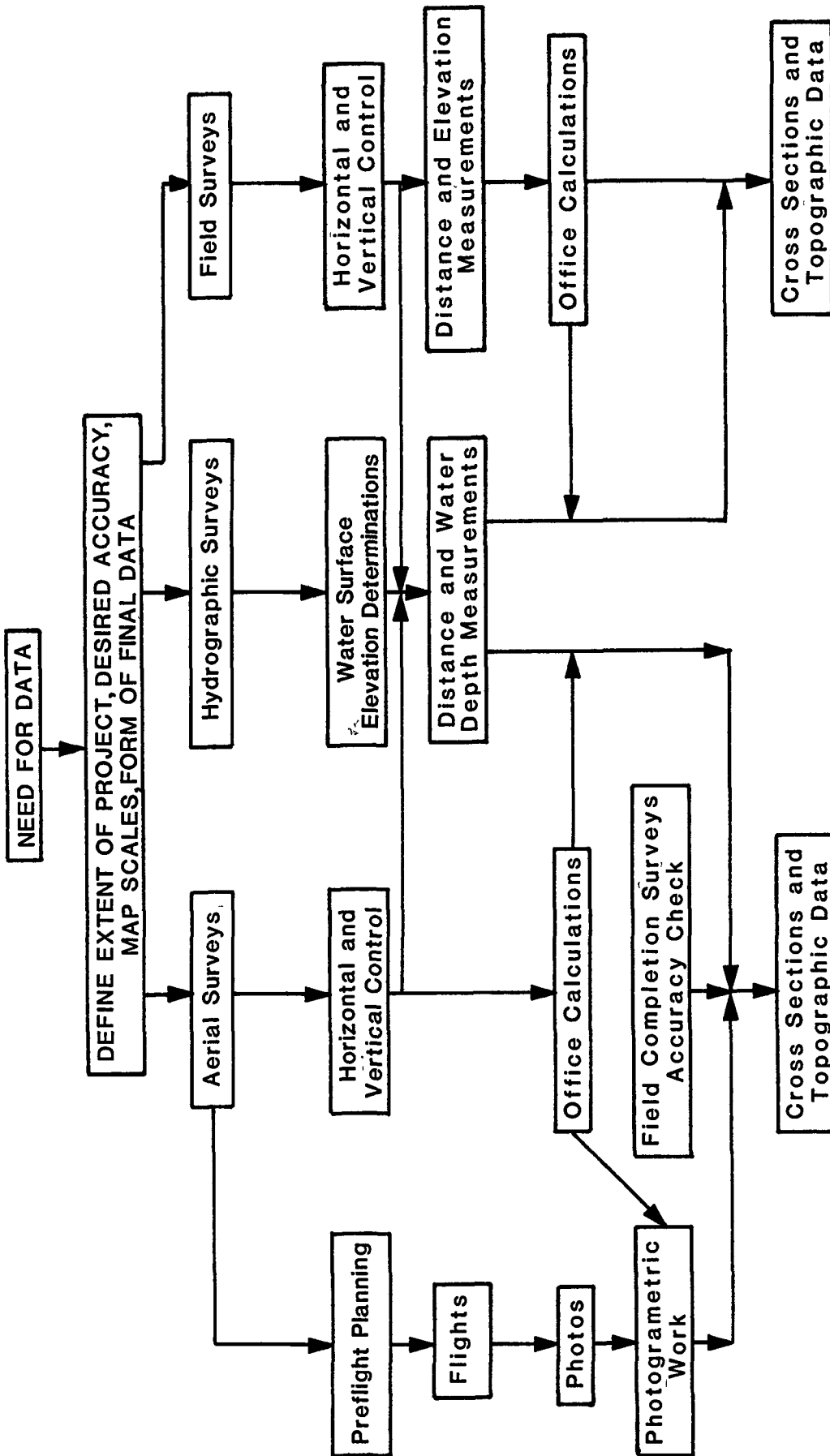

SCHEMATIC OF SURVEY PROCEDURES

and adding an appropriate depth (usually 2 to 10 feet) to ensure that the cross sections are extended high enough to contain the maximum flood discharge being evaluated, the extent and location of required cross sections can be drawn on a topographic map. The primary factor in determining the number of cross sections required is to have enough sections to reasonably represent the geometric changes within the reach. Even an approximate flood profile will indicate the constricted and expanded sections within the reach being considered. Note in Figure 2 that each cross section is located to represent a portion of the reach and each section is extended to a point outside the estimated flood outline.

The number of points required to define a cross section is keyed to representing the topographical changes within the cross section as shown in Figure 2. A section with many significant topographic changes will require more points to reasonably represent the actual section. Note section is representative of reach 1/2 distance between adjacent upstream and downstream sections. Topographic capture should be based on this as well as cross-section location.

The existence of a bridge or bridges within or near the reach being evaluated can have a significant effect on the flood stages. As-built construction drawings of existing bridges can be used to define the available bridge openings and overflow sections. If drawings are not available, a field survey crew is required to determine the key dimensions and elevations at the bridge location.

REPORT CONTENTS

This report is organized into the following six sections:

- Field Surveys
- Hydrographic Surveys
- Aerial Surveys
- Emerging Technologies
- Topographic and Cross-Section Data and Costs
- Appendices

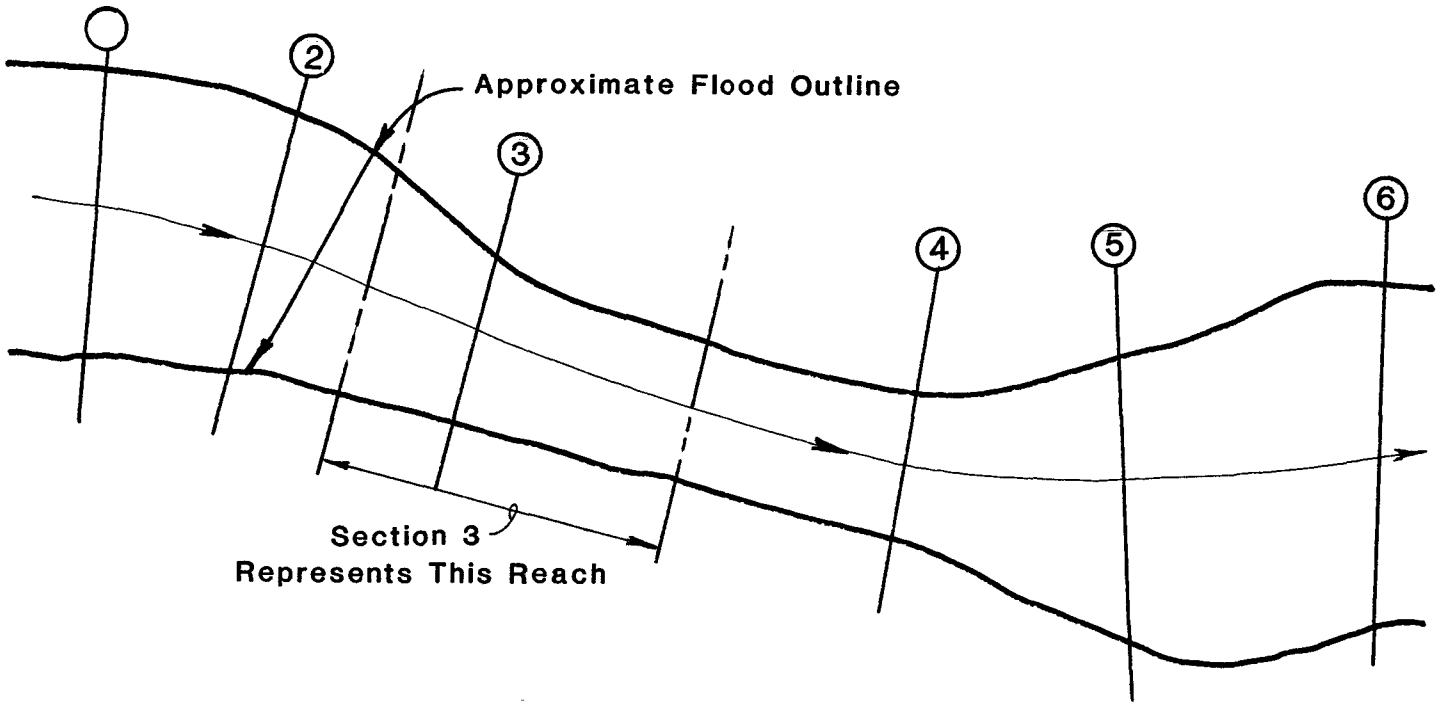

APPROXIMATE FLOOD OUTLINE

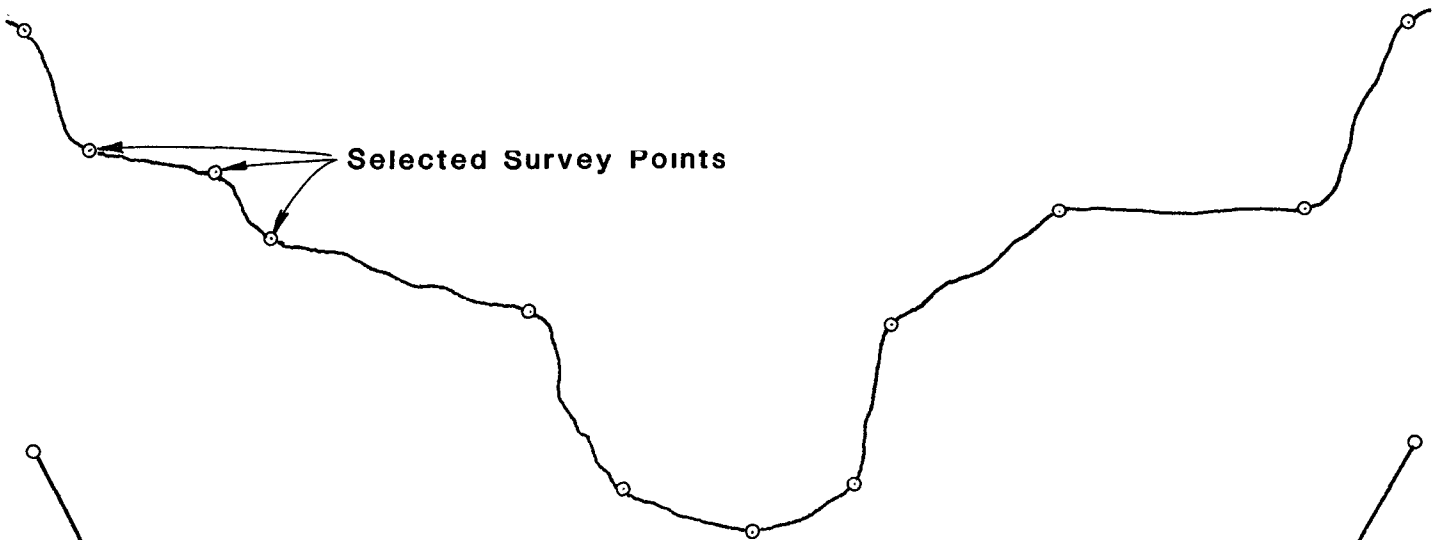

ACTUAL CROSS SECTION

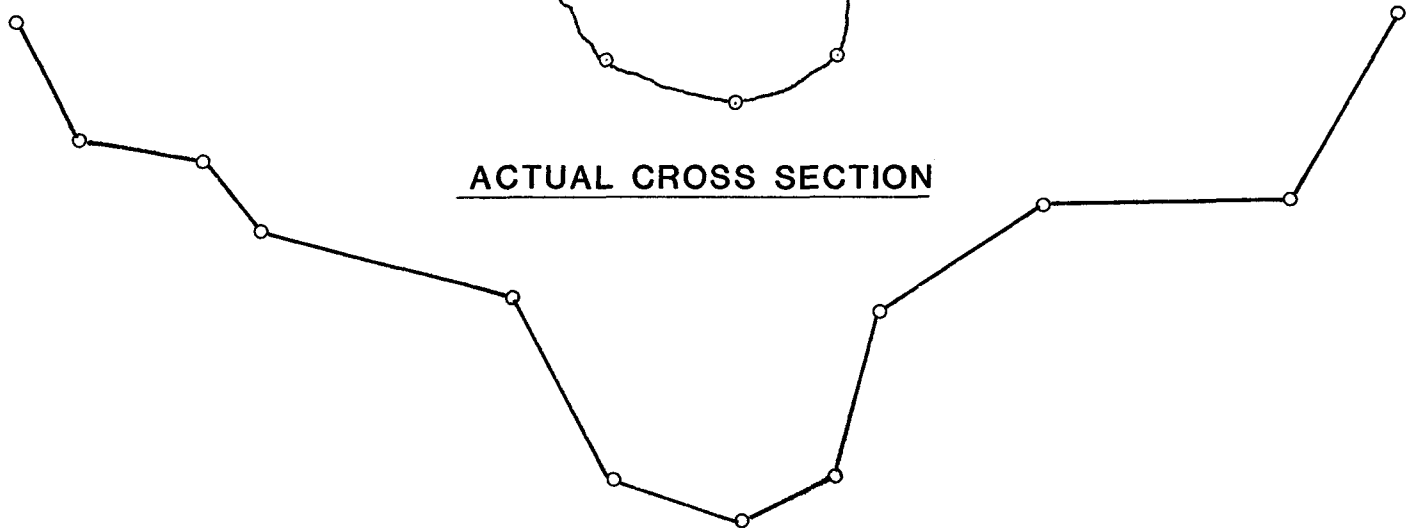

REPRESENTATIVE CROSS SECTION

**SCHEMATIC
CROSS-SECTION
DATA REQUIREMENTS**

The field survey section describes the various field survey techniques and concepts, including horizontal and vertical accuracy for each technique. Shore controlled and open water hydrographic surveys are also described. The aerial survey concepts and techniques pertinent to preparing topographic and/or cross-section data are described. A brief section is included on emerging technologies to indicate those survey equipment and techniques that may eventually replace the present commercially available technology. The final text section covers commercially available data, contracting considerations, associated costs, and survey selection considerations for developing topographic data and cross-section data.

Four appendix sections are included in this report. Appendix A contains a glossary of normally used terms in the field of aerial photography to assist readers not familiar with photogrammetry. Appendix B contains a descriptive section on technical requirements for hydrographic surveys prepared by the U.S. Army Corps of Engineers. Appendix B also contains a sample outline of a standard set of photogrammetric mapping specifications and requirements used by the Environmental Protection Agency (EPA). Discussion of the detailed specification items was beyond the scope of this study; however, it was included so the reader could gain some insight into the many items that are normally considered when performing photogrammetric work. The quantity and cost estimates prepared during this study are located in Appendix C. Labor adjustment index factors to reflect geographical labor differences are included in Appendix D, since all costs are based on Sacramento, California prevailing costs.

FIELD SURVEYS

GENERAL

This section includes a description of the various field survey equipment and the accuracies involved with the survey equipment and the applied procedures. The following items will be described:

- Hand Levels
- Conventional Levels
- Electronic Distance Meters
- Stadia and the Plane Table
- Accuracy of Field Surveys

A cross section is a vertical section of the surface of the ground taken at right angles to the flow line of the channel being studied.⁽⁴⁾ The number of, and spacing between, cross sections will vary and must be developed for each project.

Once the location and spacing between cross sections is determined, a survey control or baseline is established (see Figure 3). This baseline assists in defining the distances between cross sections and the point of beginning of the sections. The elevation of the beginning point is determined using a common elevation datum base for all cross sections. Normally, the nearest USGS or local benchmark would provide the vertical control datum based upon the Sea Level Datum of 1929. If the benchmark is not tied to a state plane coordinate system then a local coordinate system can be used to provide horizontal control.

The cross section will consist of known points of line, distance, and elevation from the cross-section point of beginning. In addition to being located at predetermined intervals, the cross-section data points should also be located at all major vertical and horizontal changes in topographic

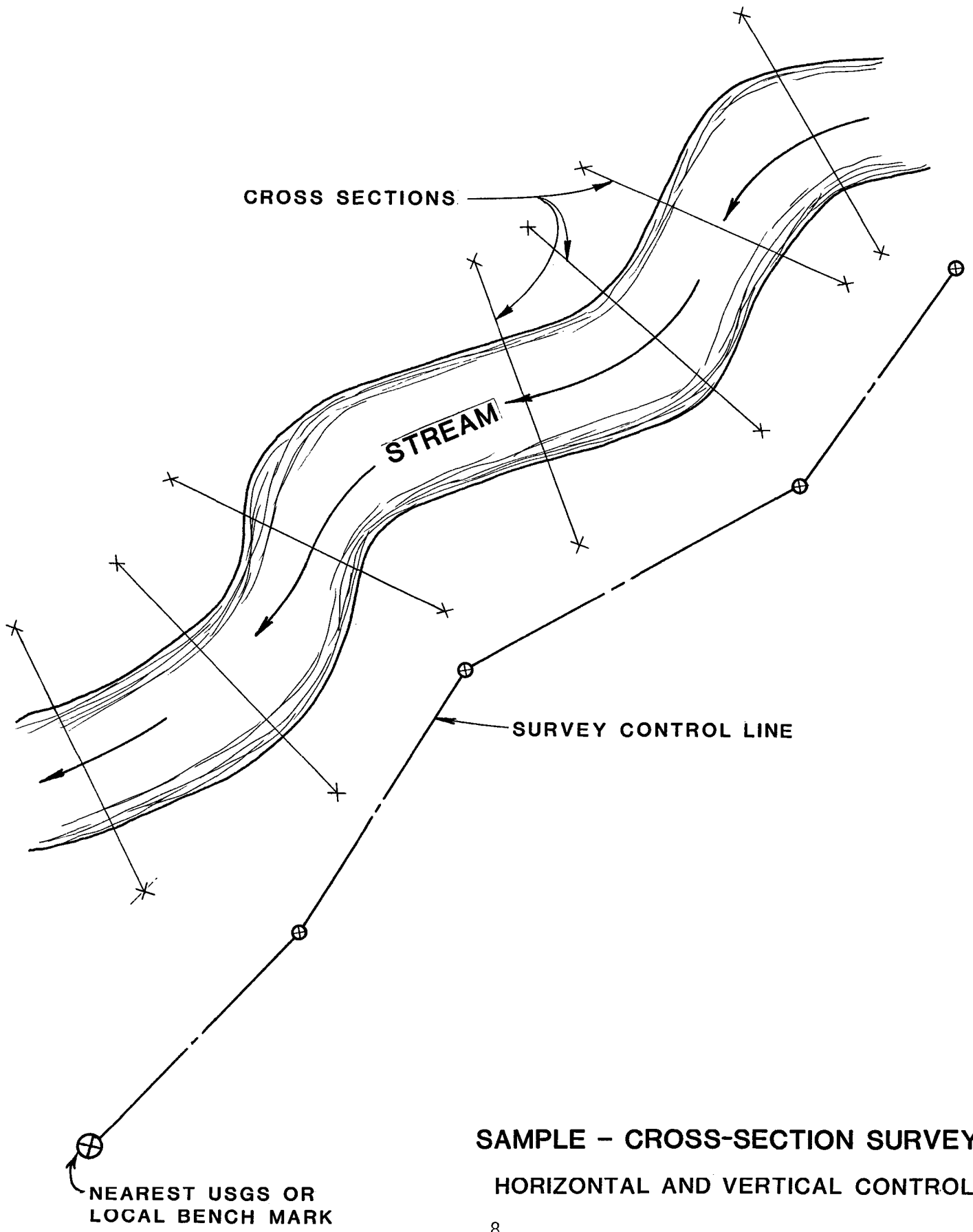

SAMPLE - CROSS-SECTION SURVEY
HORIZONTAL AND VERTICAL CONTROL

features. The specific survey method used to establish a baseline and to determine the cross sections is a function of the desired accuracy, efficiency, available equipment, manpower, and terrain conditions.

HAND LEVELS

When the cross sections are short and the vertical accuracy is not critical, the cross-section data points can be determined using a hand level and metallic tape. This is the least accurate method available to the surveyor, but small surveys can be accomplished by one or two persons. When a speedy accumulation of rough data is required this method can be economical and adequate.

CONVENTIONAL LEVELS

The most common method of determining channel cross sections is by the use of a surveyor's level, rod, and tape. The level most commonly in use is a tripod mounted "automatic" or "self-leveling" instrument. Once the instrument base plate is roughly level, the surveyor observes an image by sighting through a suspended prism hanging vertically within the instrument.

When proper procedures are observed, the use of the conventional "automatic" level still provides the most accurate method of elevation determination available to the surveyor.

Typically, the survey crew for this method of work consists of three persons. Although highly accurate, obtaining cross sections by use of conventional levels is often less time efficient than other methods available for large-scale projects.

ELECTRONIC DISTANCE METERS

Electronic Distance Meters (EDMs) measure distances by either comparing the phase differences between transmitted and returned electromagnetic waves or

by computing the distance from the round-trip transit time of a pulsed signal.⁽⁴⁾ In recent years, EDMs have combined distance measuring capacity with the ability to determine horizontal angle and vertical elevation differences. These instruments are termed "Total Stations."

By use of Total Station EDMs the horizontal position and elevation of cross-section data points can be rapidly determined. Often a two-person survey crew can efficiently survey large project areas.

The accuracy of the elevation difference data provided by a Total Stations instrument varies widely between different EDM products. The elevation difference measured in some EDMs is a product of a low precision vertical angle measurement made to compute a horizontal distance from a measured slope distance. The accuracy of the vertical angle measurement and the ensuing elevation difference computation is not highly critical in the mathematical slope reduction process and can be on the order of plus or minus one foot.

There are, however, other Total Stations instruments currently available that are specifically designed to provide accurate elevation measurements. With reasonably good atmospheric conditions, instrument sighting techniques and moderate elevation data point distances, elevation differences can be obtained on the order of plus or minus 0.1 foot.

Horizontal locations are accurately determined by all major types of EDMs currently available. Some EDMs can store survey cross-section point data on cassette tape for transfer to office plotters. This can increase survey efficiency, especially in large-scale projects.

STADIA AND THE PLANE TABLE

Stadia is a technique of distance measurement involving the observation by the surveyor of the distance subtended on a graduated rod between two marks

on the reticle of the telescope of a survey transit or theodolite.⁽⁴⁾ Mathematical reduction of the subtended rod distance and the horizontal and vertical angles allows the surveyor to determine the horizontal data point location and elevation.

Each cross-section point requires five numerical entries, so stadia surveys generally require a three-person crew comprised of an instrument man, rodman, and notekeeper. Stadia surveying methods are properly applied to small project areas with an expected horizontal accuracy of plus or minus one to five feet and a vertical accuracy of plus or minus 0.5 feet.

Although no longer frequently observed in current surveying practice, the above described stadia techniques can be used in conjunction with a plane table. A plane table is a level drawing board located directly over a known baseline control point in the field. A stadia instrument is mounted directly on the plane table surface. Topographic features can be directly plotted in the field. Expected horizontal accuracies are the same as for standard stadia surveys and a slight decrease in vertical accuracy should be expected. However, for some small project areas the decrease in finish drawing production time may make the use of a plane table a viable consideration.

ACCURACY OF FIELD SURVEYS

Accuracies for horizontal angles, horizontal distance, and vertical distance for various types of equipment are indicated in Tables 1, 2, and 3, respectively.

TABLE 1
 SURVEY EQUIPMENT PROCEDURE ACCURACY
 HORIZONTAL ANGLES

Type of Equipment	Accuracy	Remarks
Compass	$\pm 0^{\circ} 30'$	Careful use of a staff mounted 6-inch compass will give good relative angle measurements. Better results from an Engineers Transit Mounted Compass, results to $\pm 0^{\circ} 15'$.
Builders Transit	$\pm 0^{\circ} 01'$	Of limited value except for local, limited area work. Optics and instrument condition usually less than optimum.
Engineers Transit	$\pm 0^{\circ} 00' 30''$	A standard tool for 100 years. Properly handled by a skilled instrument man can produce results of $\pm 0^{\circ} 00' 10''$.
Total Station or Theodolite	$\pm 0^{\circ} 00' 01''$	Depends upon type of instrument readily capable of angular measurements to $\pm 0^{\circ} 00' 01''$.
Right Angle Prism	$\pm .05'$	A precise tool for measurement in a horizontal plane and for a limited distance.

Source: American Congress on Surveying and Mapping and the American Society of Civil Engineers, "Definitions of Surveying and Associated Terms," reprinted 1981.

TABLE 2
 SURVEY EQUIPMENT PROCEDURE ACCURACY
 HORIZONTAL DISTANCE

Type of Equipment	Accuracy	Remarks
Pacing	$\pm 1.0'/100'$	Depending upon terrain, can be useful for relatively gross positioning.
Cloth Tape	$\pm 0.20'/100'$	Useful for determining postions of a non-critical nature.
Stadia	$\pm 1.0'/500'$ ^{1/}	Accuracy can be improved by approximating horizontal measurements using a rod and adjustable target setting to measure subtended distance.
Steel Tape	$\pm 0.01'/100'$	The standard measurement tool.
Electronic Distance Measurements (E.D.M.)		Depends upon type, capable of measurements to 0.001 foot over distance of 100.00 feet to 20 to 50 miles.
Satellite Positioning		A measurement tool particularly adapted to large area surveys. Future positioning in space of a greater number of satellites (23 anticipated) will result in greater precision in a shorter time interval.

^{1/} Accuracy is not proportional to distance.

Source: American Congress on Surveying and Mapping and the American Society of Civil Engineers, "Definitions of Surveying and Associated Terms," reprinted 1981.

TABLE 3
SURVEY EQUIPMENT PROCEDURE ACCURACY
VERTICAL

Type of Equipment	Accuracy	Remarks
Hand Level	$\pm 0.2'$ @ 50'	With support of level and careful sighting, can obtain $\pm 0.1'$ @ 50'.
Stadia	$\pm 0.4'$ @ 500'	Using double target intercept of rod can expect $\pm 0.2'$ @ 500' slopes less than 30°.
Alidade ^{1/}	$\pm 0.10'$ @ 200'	Useful for topo detail in a limited area, results similar to stadia.
Conventional Level Wye-Dumpy	$\pm 0.50'$ @ 800'	Sights limited to 200' to 300' can produce readings to 0.01'. Depends upon visibility conditions and skill of observer.
Automatic Level	$\pm 0.03'$ @ 800'	Automatic level results similar, but faster in operation than conventional levels.
E.D.M. with Theodolite or Total Station	$\pm 0.05'$ @ 500'	Depends upon type of instrument and skill of operator.
Barometer	+ 2.0' within 1.0 hour time interval of observations	Barometric pressure changes rapidly with storm conditions. For longer time intervals, must use a recording base station in order to determine changes of atmospheric pressure as a comparison.

^{1/} An Alidade is the portion of a surveying instrument which consists of a sighting device (telescope) with index and reading or recording accessories (index plate to record angles).

Source: American Congress on Surveying and Mapping and the American Society of Civil Engineers, "Definitions of Surveying and Associated Terms," reprinted 1981.

HYDROGRAPHIC SURVEYS

GENERAL

Hydrographic surveys may be needed when the stream or river is of such a size and depth that normal field surveys or aerial survey techniques (at low flow conditions) cannot be performed. Hydrographic surveys may be categorized as either shore controlled or open water surveys. The establishment of an elevation datum base is a key factor in the successful performance of both types of surveys. This datum will allow the surveyor to measure the effects of tides and/or storm water run-off.

Water surface elevation fluctuations are typically measured by observation of tide boards referenced to project datum. Tide boards should be placed in sheltered locations to minimize the effects of wave motion on the observed readings. In tidal areas, readings should be taken at maximum intervals of thirty minutes.

In recent years, components have become available to allow the construction of recording tide gauges. When properly baffled against local wave motions, recording tide gauges can greatly enhance survey accuracy and efficiency.

Since the advent of electronic distance meters, the project areas within the category of shore controlled surveys have greatly expanded. Small projects can still be adequately performed by use of a person on shore with a theodolite to position the soundings boat on the cross-section line. Horizontal distance can be measured by use of a tag line and reel. Vertical readings are observed by lead line measurements at specified intervals. The accuracy of this basic method is greatly effected by stream and tidal currents which can bow the tag line and interfere with a proper vertical lead line measurement.

Replacement of the tag line by use of EDMs also greatly increases accuracy, range, and efficiency. Typically, one person at shore control points can position the boat on the cross-section line and at required intervals

communicate distance measurement by two-way radio. Use of EDMs has allowed survey work to be performed at ranges in excess of one mile from onshore survey control points.

Fortunately, shore controlled hydrographic surveys can be upgraded in each of the above described functions to provide increased accuracy, survey area size, and efficiency. The use of recording sonar (Sound Navigation Ranging) equipment is the most basic improvement. The recording sonar equipment measures water depth by noting the time interval required for sound waves to travel from a source of sound near the surface to the bottom and back. The water surface and bottom profile is recorded on a moving chart. Under calm water conditions vertical measurements can be made at moderate boat speeds with a tolerance of plus or minus 0.1 foot. As a minimum requirement, sonar equipment calibration checks ("bar checks") should be made at least three times daily. It should be noted that the recording sonar does not give an indication of bottom composition and readings can be effected by underwater vegetation. Since the recording sonar will pick up the top of loose fluffy material, the results can be misleading. During flooding conditions with high river stream velocities the loose fluffy material will be washed out and the section area will be somewhat larger than the area based on sonar readings taken during calmer conditions.

The elements of a sonar system are shown on the following sketch⁽⁵⁾:

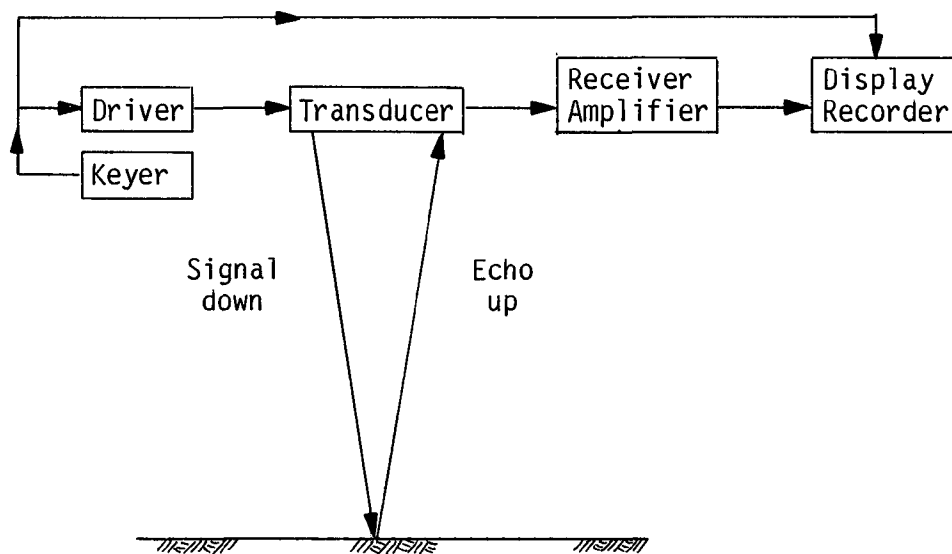

These elements are described in reference⁽⁵⁾ as follows:

Driver -- Provides the electrical power at the right frequency and amount.

Keyer -- Keys the driver at the right time and for the proper duration.

Transducer/Hydrophone -- Converts electrical energy from the driver to acoustic energy and converts the echo received from the bottom into electrical energy.

Receiver Amplifier -- Receives and amplifies the returned signal from the transducer.

Display/Recorder -- Indicates the depth of water to the user.

The accuracy of determining the platform's distance above the river bottom is dependent upon the SONAR's frequency, the water's scattering properties, and the channel bottom's reflectivity or softness. High frequency SONAR gives good resolution, while low frequency SONAR results in poor resolution. Consequently, most of the hydrographic equipment will use a frequency of between 20 and 40 kHz to achieve good resolution. Scattering is caused by fish, plants, and other particulate matter in the water. Soft bottoms will absorb more energy than hard bottoms and less energy is reflected back to the ship.⁽⁵⁾

Open water hydrographic surveys, where the project area cannot be controlled by onshore control points, are not encountered often due to the advent of EDM equipment. Most open water hydrographic surveys are controlled by inertial positioning equipment with onboard computers, plotters, and recording sonar equipment (see Figure 4).

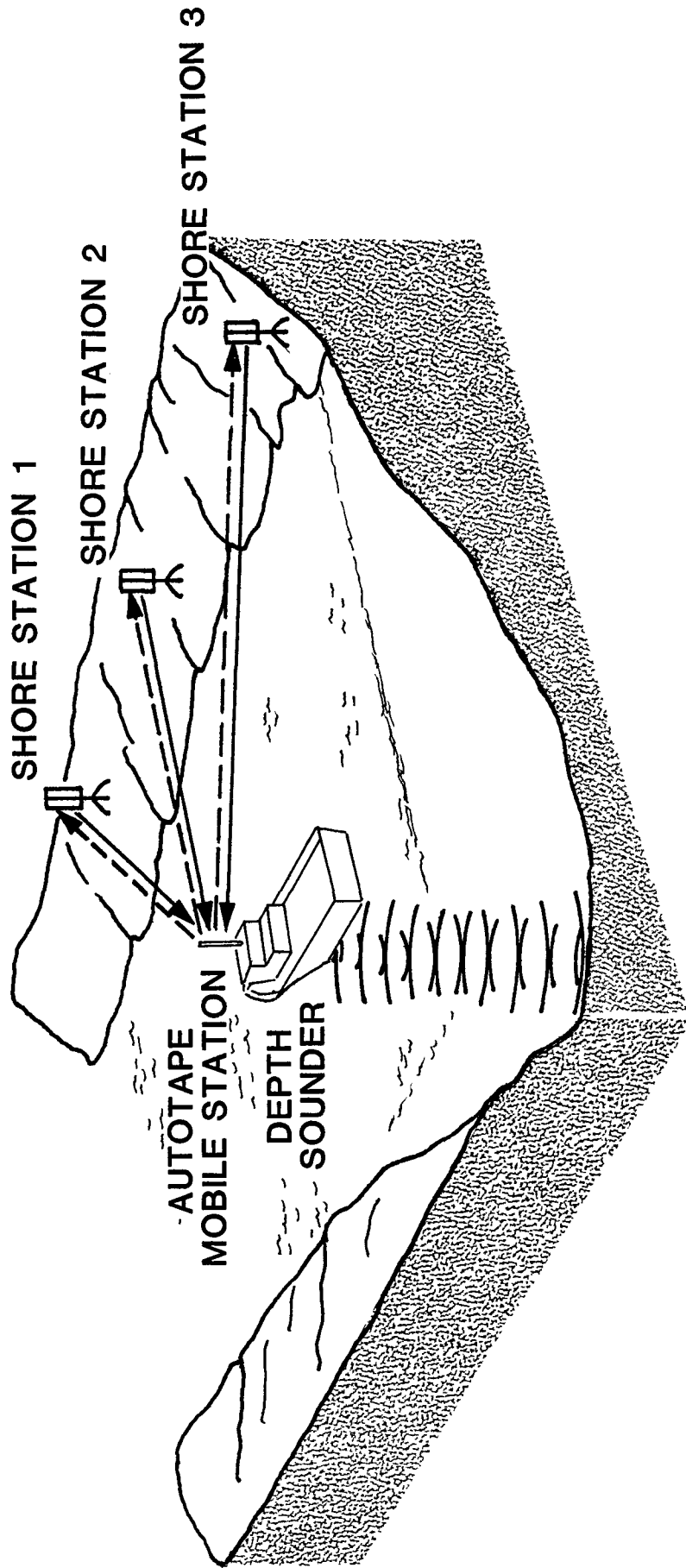

SOURCE: "Fully Automated Electronics Used To Monitor Contractor Dredging Operations", Jacksonville District Corps Of Engineers, World Dredging And Marine Construction. September 1981

HYDROGRAPHIC SURVEYS
PLATFORM POSITIONING

ACCURACY

All hydrographic survey techniques discussed have a vertical accuracy that is directly effected by the water conditions. Under calm conditions, vertical accuracy can be within the range of plus or minus 0.1 foot. With proper care, horizontal accuracy can be within plus or minus one to five feet using various methods discussed within this report.

An additional description of the technical requirements of hydrographic surveys is included in Appendix B.

AERIAL SURVEYS

GENERAL

This section provides an elementary understanding of the aerial photography process for development of topographic mapping and cross-section data. The discussion is limited to the steps necessary to develop data for use in analyzing water surface profiles.

Moffitt and Mikhail⁽⁶⁾ in their book provide the following definition of photogrammetry:

"In its restricted sense, the term photogrammetry means the process of measuring images on a photograph. In a more comprehensive sense, photogrammetry includes: (a) photographing an object; (b) measuring the image of the object on the processed photographs; and (c) reducing the measurements to some useful form such as a topographic map."

Prior to performing a water surface profile analysis on a reach of river, a typical request for topographic and cross-section data would require providing the following:

- Aerial Photos
- Horizontal and Vertical Ground Control
- Topographic Mapping at Specified Scales and Accuracy
- Spot Elevations Along Specific Cross Sections

The basic concepts and techniques to provide these services and pertinent accuracy information are briefly described below.

CONCEPTS AND TECHNIQUES

The concepts and techniques are keyed to the following steps in the process of providing aerial survey services:

- Preflight Planning
- Horizontal and Vertical Ground Control
- Flights
- Analytical Bridging
- Photogrammetric Work
- Field Survey Checks
- Final Products

Preflight Planning

The preflight planning involves determining the flight elevation and pattern to be used to cover the project area and to coordinate with a surveyor the approximate locations and number of horizontal and vertical control points required. Table 4 is a sample photogrammetry map planning chart. See the illustration on Figure 5 to determine flying height. Since the stereoscopic viewing devices utilize overlapping pairs of photographs to perform the photogrammetric work, the flight plan must include the amount of both forward and side overlap required. Typically, a USGS quadrangle map is sufficient to lay out the flight plan. Either all or a portion of the horizontal and vertical control can be provided by field surveys. Depending upon a number of factors affecting costs including types of terrain, ground cover, access and size of project, the number of control points to be set might be limited to minimize field work. Then photogrammetric computational procedures (analytical bridging) could be used to mathematically link the zones between control points.

TABLE 4

PHOTOGRAMMETRY MAP PLANNING CHART

Map Scale 1"= (feet)	Photo Scale 1: (feet)	Contour Interval (feet)	Accuracy ^{1/} Contour (feet)	Accuracy ^{1/} Spot Elev. (feet)	Horizontal (feet)	C ^{2/} Factor	Flight Alt. Above Ground	Ground Control Cross Size ^{3/}	Model Overlap	Gain ^{4/} Side	Acres ^{5/} Full Model
40	2,400	1	.6	.3	1.3	1,200	1,200	4' x 4"	720	1,260	21
50	3,000	2	.8	.4	1.7	750	1,500	4' x 4"	900	1,575	33
60	3,600	2	.9	.5	2.0	900	1,800		1,080	1,890	47
80	4,800	2	1.2	.6	2.6	1,200	2,400	8' x 6"	1,440	2,520	83
100	6,000	5	2.0	1.0	3.3	600	3,000		1,800	3,150	130
150	9,000	5	2.3	1.2	5.0	900	4,500		2,700	4,725	293
160	9,600	5	2.4	1.2	5.3	960	4,800	12' x 12"	2,800	5,040	333
200	12,000	5	3.0	1.5	6.6	1,200	6,000		3,600	6,300	520
300	18,000	10	4.5	2.3	9.9	900	9,000		5,400	9,450	1,171
400	24,000	10	6.0	3.0	13.2	1,200	12,000	Photo Indent.	7,200	12,600	2,083
500	30,000	15	7.5	3.8	16.5	1,000	15,000		9,000	15,750	3,254
600	36,000	20	9.0	4.5	19.8	900	18,000		10,800	18,900	4,686

^{1/} The accuracy that can be projected to any given photogrammetric project is influenced by the following factors:

1. Type of aerial camera. A distortion-free camera should always be used.
2. Type of terrain and haze. Use of special light filters and chemistry enhances negative quality.
3. Stereo Plotter.

^{2/} C-Factor = flight height/contour interval.

^{3/} Refers to overall dimensions of cross and thickness of arms.

^{4/} Gain = the amount of new coverage on a photograph in a line of connected photography (distance between photo centers).

^{5/} Model = the area covered by a pair of photos in stereo plotting.

Source: Brochure from Cartwright Aerial Surveys Inc., Sacramento California.

$$S_h = \frac{f}{H-h}$$

Where S_h = Scale At Elevation h , in./ft.

f = Focal Length, Inches

H = Flying Height Above Datum, Feet

h = Average Elevation On Ground

ILLUSTRATION

Given: Focal Length, $f = 6''$

Average $h \approx 980'$

Determine: Flying Height For Photo Scale Of $1'' = 400'$ ($1'' = 4800'$)

$$S_{980} = \frac{6''}{H-980'} = \frac{1''}{400'}$$

$$H = \frac{(400)(6'') + 980}{(1'')}$$

$$H = 2400 + 980$$

$$H = 3380' \text{ Above Datum}$$

$$\text{Altitude Above The Ground} = 2400 \text{ Feet}$$

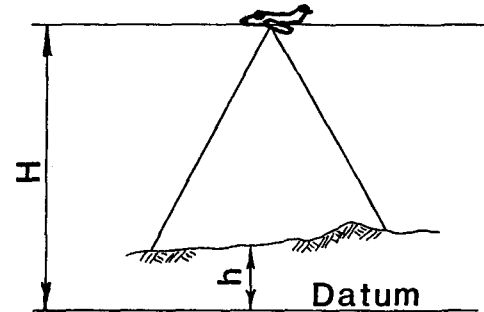

Ref: Moffitt, Francis and Mikhail, Edward;
Photogrammetry, Harper and Row,
Third Edition, 1980

ILLUSTRATION
DETERMINATION OF FLYING HEIGHT

Horizontal and Vertical Ground Control

Control points are established by field surveys to serve as the basis for horizontal and vertical control of the area being photographed. If there is a requirement to tie into a national or local datum then some research is required to locate the closest benchmark monument. The horizontal and vertical control would start at that monument and the control would be brought to the project area to set the required numbers of control points. The control points must be marked in a cross pattern such that they will be sufficiently visible in the photographs. See Table 4 for suggested dimensions of the ground control cross size.

Flights

The flights are normally timed to take photographs when there is a high sun angle to eliminate as many shadows as possible. However, there are a few exceptions to the high sun angle approach. When the flight is to cover steep canyon slopes, the early morning or late afternoon may give maximum lighting to the slopes. Also, low sun angle photography for flat areas with very low and sparse vegetation may provide a better stereo model.

When the area to be photographed has heavy vegetative cover it is best to plan to take the flights during the winter season.

Analytical Bridging

Analytical bridging is a mathematical solution to extend field control points and is normally done photogrammetrically with the aid of computers. When access to the project area is difficult and/or the terrain is rugged it is often economical to minimize the field work by mathematically bridging together fewer field control points.

Photogrammetric Work

Plates are made from the flight negatives and are used in the plotter to perform the photogrammetric work of plotting contour lines and determining spot elevations.

Field Survey Checks

Often there are areas with ground cover that the camera cannot pick up and field surveys are required to complete the mapping or cross-section work. If extensive analytical bridging was done it might be prudent to field check a few locations.

Final Products

In addition to providing the aerial photos, topographic mapping, ortho-photos, and cross-section spot elevations, equipment is readily available to digitize the location and elevation of all points on the map. Cross-section input data for the HEC-2 Water Surface Profile program (GR Cards) can be produced directly using existing photogrammetric systems.

Latest Equipment

The analytical stereoplotter is the latest state-of-the-art instrument in photogrammetry available for use today. This system ties together the stereo equipment to a process computer, data storage system, digital plotting table, and a printer for hard copy output of data. An advantage of this type of equipment is the improvement of numerical data acquisition and processing. Data for cross sections are easily developed, stored, and/or plotted. Users have reported that performing analytical bridging is about three times more efficient and developing cross sections is at least two times more efficient using the analytical stereoplotter.⁽⁷⁾

ACCURACY

Accuracy, as defined in reference⁽⁸⁾, "is the degree of conformity with a standard or a measure of closeness to a true value." Table 5 indicates the criteria that is used to define standard map accuracy. Note that Table 4 indicated accuracies for contours, spot elevations, and horizontal locations at different map scales. Generally, the contour accuracy is slightly better than half of the contour interval while the accuracy of spot elevations is approximately 20-30 percent of the contour interval of the map being prepared. Therefore, it is noted that cross sections developed using contours from topographic maps will not be as accurate as cross sections prepared from spot elevations developed with stereoscopic plotters. Errors are random and, therefore, each cross section will tend to balance those errors.

TABLE 5
ACCURACY OF MAPS^{1/}

Map accuracy may be determined by comparing plotted planimetric and topographic features to their true or calculated positions on the earth's surface. Standard Map Accuracy is defined by the following criteria:

1. The plotted position of all coordinate grid ticks and monuments, except benchmarks, will be within 0.01 inch from their calculated positions.
2. At least 90 percent of all well-defined planimetric features shall be within 0.033 inch of their true positions, and all shall be within 0.066 inch of their true positions.
3. At least 90 percent of all contours shall be within one-half contour of true elevations, and all contours shall be within one contour interval of true elevation, except as follows:

For mapping at scales of 1" = 100' or larger in areas where the ground is completely obscured by dense brush or timber, 90 percent of all contours shall be within one contour interval or one-half the average height of the ground cover, whichever is the greater, of true elevation. All contours shall be within two contour intervals or the average height of the ground cover, whichever is the greater, of true elevation. Contours in such areas shall be indicated by dashed lines.

Any contour which can be brought within the specified vertical tolerance by shifting its plotter position .033 inch shall be accepted as correctly plotted.

At least 90 percent of all spot elevations shall be within one-fourth the specified contour interval of their true elevation, and all spot elevations shall be within one-half the contour interval of their true elevation, except that for 5-foot contours 90 percent shall be within 1.0 foot and all shall be within 2.0 feet.

^{1/} Source: Brochure from Cartwright Aerial Surveys Inc., Sacramento, California.

EMERGING TECHNOLOGIES

INTRODUCTION

The future of topographic surveying appears to be in the use of remote sensing, inertial surveying, positioning from satellites, and advanced electronics. Someday desired topography or cross sections, if not obtainable from a national digitized data base, could be obtained routinely from aircraft using laser or radar beams which are positioned by inertial, laser, or satellite systems (see Figure 6). The data gathered would be fed automatically into a computer for determination of the needed topographic data. Surprisingly, the technology for implementing most of these predicted developments already exists. And it is only a matter of time before these and other developments find their way into practice in the aerial surveying, hydrographic surveying, and data manipulation areas of topographic mapping and development of cross sections.

AERIAL SURVEYS

Aerial topographic mapping can or may someday be accomplished by either advanced photogrammetric techniques or by recently developed electromagnetic ranging systems (Light Distance and Ranging (LIDAR) and radar).

Future advances in photogrammetric surveying may include the use of artificial intelligence (AI) technology for performing aerial photo interpretation. Scientists at the U.S. Army Corps of Engineers' Engineering Topographic Laboratory (ETL) are investigating the application of AI technology to such problems as feature extraction from aerial imagery.⁽⁹⁾

Aerial distance measuring devices, using electromagnetic waves, are relatively new. The velocity of propagation of electromagnetic waves in the atmosphere is known. Therefore, the time the pulse takes to bounce off the terrain or object and return to the emitting device is measured and the distances can be calculated. These devices work on the principle of measur-

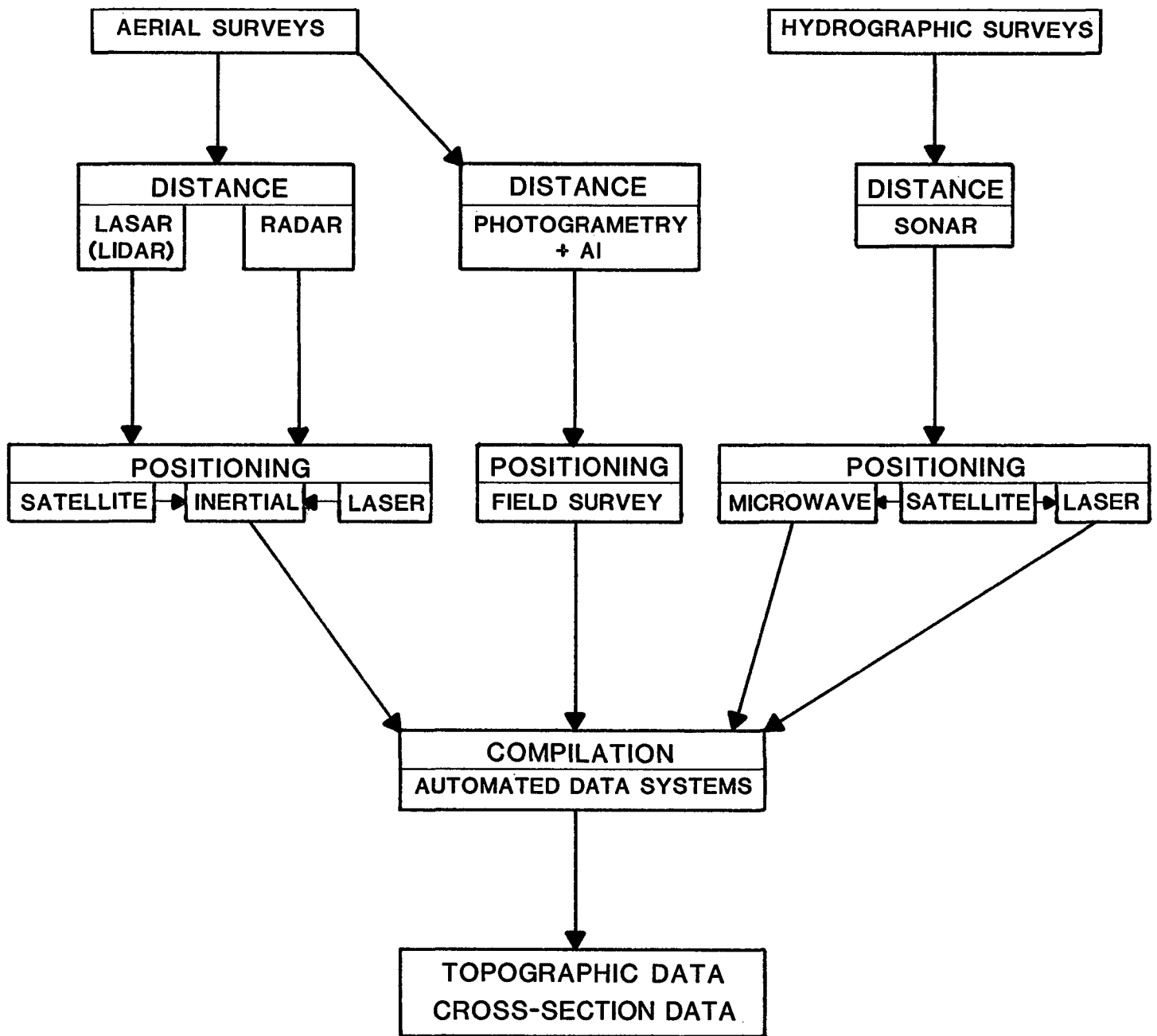

SCHEMATIC
EMERGING TECHNOLOGIES

ing distances to the topography from a platform accurately located in a three-dimensional reference frame as shown in Figure 7. The distance measurements are made using a "tight" beam (laser or radar wave) that has a small "footprint" on the ground and thus there will be less variation in elevation within it.⁽¹⁰⁾

Long wave radar devices have been developed and tested which are capable of determining the topography of terrain covered with a dense canopy. These types of devices are not yet commercially available and presently only have a vertical accuracy of about ± 5 feet.⁽¹¹⁾

LIDAR systems are commercially available and achieve a higher degree of accuracy. The USGS, in a series of performance evaluation flights in 1984, indicated vertical accuracies of ± 0.5 feet could be achieved for 90 percent of the points along a profile.⁽¹²⁾

The platforms (flying vehicles) used for aerial distance measuring must be capable of accurately maintaining their X, Y, and Z positional information in order to produce topography and cross sections. An Inertial Measuring Unit (IMU) provides this capability. The IMU must, however, periodically update its position. This can either be done by landing at control points or using laser trackers which measure its position from reflectors at surveyed locations on the ground. The reflectors' positions may be established by either conventional survey techniques or by using the Global Positioning System (GPS) satellites developed for the U.S. Navy. This system has several satellites which circle the earth along known paths every 107 minutes, and at least one satellite will pass within sight of all points on the earth every 35 to 100 minutes. Reflector positioning using the GPS satellites is determined based upon measuring the Doppler shift in the satellite signals and knowing the satellite's position at any specific time.⁽¹³⁾

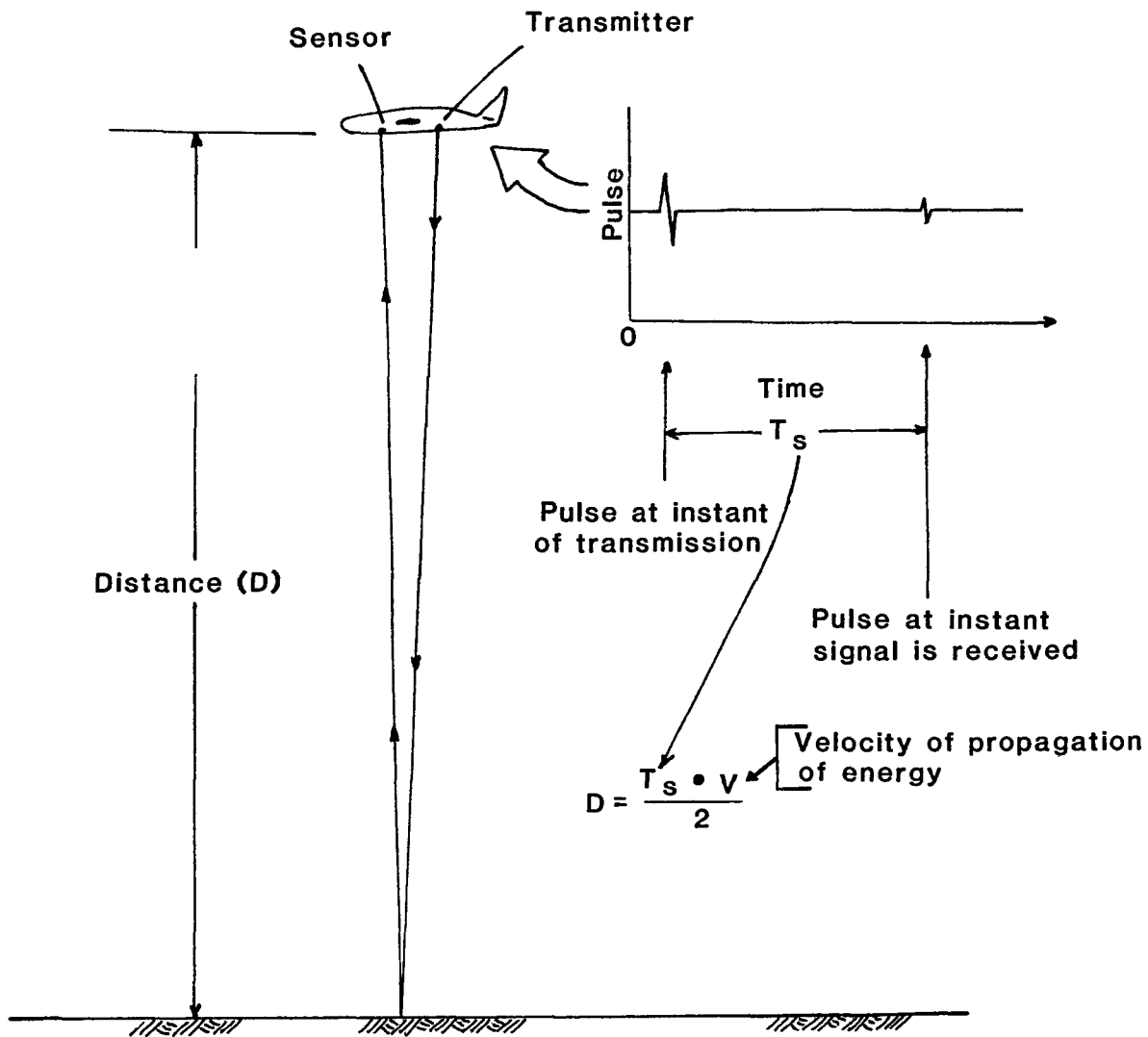

Ref: Engineer Pamphlet 70-1-1 Oct. '79
 Remote Sensing Applications Guide Part 2 of 3, Pg. 3-42
 Dept. of the Army Office, Chief of Engineers

SCHEMATIC
AERIAL DISTANCE MEASURING DEVICE

HYDROGRAPHIC SURVEYS

Water is a more difficult medium than air to work with since it is difficult to radiate energy into and difficult to transmit energy through for any great distance. There is also difficulty in interpreting signals received under water.

In water, the shorter the sensing wave length the greater the attenuation or weakening of the signal. However, going to longer wavelengths reduces the resolving power that makes the shorter wavelengths, like light, so attractive. It is possible, though, to use blue-green lasers or radar to perform hydrographic surveys in shallow water, but technologies using these forms of energy are not currently commercially available.⁽¹¹⁾ Therefore, of the entire spectrum of radiated energy only the acoustic (sonar) area yields useful results when measuring depths in excess of a few tens of feet.

AUTOMATED DATA SYSTEMS TECHNOLOGY

Thompson, a Research Civil Engineer for the topographic Division of the U.S. Geological Survey, indicated the following future objectives of surveying and mapping:⁽¹⁴⁾

"Land data records computerized in a universal coordinate system; a new unified work datum ellipsoid; widespread use of image maps and thematic maps; and a control bank of digitized cartographic information."

During recent years, the technological impact of electronics has affected every field of surveying. In the very near future, nearly every advanced tool we use will contain some kind of computer device. Automated computer systems will provide the capability to record, edit, analyze, store, print, and plot the measured cross sections or topography. Electronic data recording of field measurements will reduce error, improve efficiency, and allow transfer of data directly into a computer for hydraulic modeling. Advanced electronic systems have already been used to initiate a nationwide digital cartographic data base.

In a paper presented at the 1985 Surveying Conference in Vicksburg, Mississippi,⁽¹⁵⁾ it is seen that the government is moving toward digitized cartographic information. During the early 1970s, the USGS coordinated an effort to determine federal requirements for digital cartographic data. By 1982 the Department of Interior established the Interior Digital Cartography Coordinating Committee and the USGS was given the authority to develop and manage a National Digital Cartographic Data Base. In 1983 the USGS was given the lead federal role for the newly established Federal Interagency Coordinating Committee on Digital Cartography. Working groups have been set up to monitor current federal mapping efforts, to identify federal digital cartographic requirements, to develop standards, to improve technology exchange, and to facilitate applications of the digital cartographic data.

SUMMARY STATEMENT

The technology for implementing most of the predicted developments already exists. The costs to utilize these emerging technologies are relatively expensive compared to present commercially available surveying methods. Hopefully the costs for applying the emerging technologies will become more competitive in the near future.

TOPOGRAPHIC AND CROSS-SECTION DATA AND COSTS

GENERAL

This section includes information on available topographic and cross-section data, contracting considerations to procure the data required, associated costs to develop topographic mapping and cross-section data, and the selection considerations of field or aerial surveys for a particular project.

AVAILABLE DATA

During the initial phase of a new project it is generally useful to locate available mapping and/or cross-section data and utilize that data to determine what additional information is required to complete the project. During this period, all of the surveying and mapping required for that project should be defined. This will allow the project manager to develop an economical plan to accomplish all of the field and aerial survey work required.

USGS Quadrangle Maps

U.S. Geological Survey (USGS) quadrangle maps and aerial photos are good sources of information to evaluate prior to setting up field or aerial survey programs. Typically, USGS quadrangle maps, at scales of 1:62,500 (15-minute, approximately 1" = 1 mile) and 1:24,000 (7 1/2-minute, 1" = 2,000'), are available and can be purchased from surveying supply stores or from the USGS directly. These maps are normally sufficient to lay out the scope and extent of the floodplain being considered. The topography provides a good indication of the type of terrain and the color coding indicates the general type of ground cover.

Topography is prepared to National standards and the accuracy of each map is keyed to the contour interval. The contour interval will vary from map to map depending upon the amount of relief at the individual locations.

These quadrangle maps are tied together with permanent vertical and horizontal control points (monuments or benchmarks) some of which are shown on the quadrangle maps. A complete list of the permanent control points for each 15-minute quadrangle map is published and is available for purchase from the USGS. If it is necessary to tie into the National coordinate system for horizontal control or the vertical datum for vertical control, the location of the nearest monument will be helpful in determining the effort required to perform the field control surveys.

Federal and Local Agency Data

Many federal, state, and local agencies have available topographic mapping, aerial photos, and floodplain cross sections prepared for ongoing or previously studied projects. Federal agencies such as the Federal Emergency Management Agency (FEMA), the U.S. Army Corps of Engineers, the U.S. Bureau of Reclamation, the Soil Conservation Service, and the Forest Service are some of the key agencies that should be contacted to determine if they have data pertinent to the project being initiated. FEMA has been administering the ongoing National Flood Insurance Program for approximately ten years. Topographic mapping and cross sections are required to determine the elevation and the extent of the 100-year floodplain as part of the flood insurance studies. Many Corps of Engineer districts located throughout the United States have developed 100-year floodplain information for a large number of individual flood control projects. Typically, aerial photographs, topographic mapping, and cross sections are available as a result of these studies. State and local agencies often have topography prepared for various planning or specific project reasons that are done at scales and levels of accuracy that could be a vast improvement over the quadrangle maps.

Commercial Sources of Data

Aerial photography and topographic mapping are also available from local aerial survey and mapping companies. These companies normally keep negatives of the aerial photos and subsequent mapping prepared for previous clients. Prints can be purchased from the aerial survey and mapping companies after approval has been received from the client who paid for the initial service.

Available sources of data should be pursued before requesting new field or aerial surveys. "As-built" design drawings for existing bridges upstream or downstream from the reach in question are normally available and can be a valuable source of information. One or two weeks of contacting key federal, state, and local agencies, as well as local area survey mapping companies, could save significant project funds.

CONTRACTING CONSIDERATIONS

Typically, contract specifications for hydrographic, field, and aerial surveys to prepare topographic mapping are quite detailed. Normally, each agency has a standard set of specifications and technical instructions to be utilized by the contractor to perform the work. At the February, 1985 Surveying and Mapping Conference, the Corps of Engineers presented a draft version of Technical Requirements for Surveying and Mapping Services.⁽¹⁶⁾ A brief description of hydrographic surveys and the technical requirements are excerpted from that document and presented in Appendix B to provide additional background information. Another example of a standard set of specifications were prepared by the Environmental Protection Agency (EPA) entitled, EPA Photogrammetric Mapping Specifications and Requirements.⁽¹⁷⁾ These specifications include sections on Aerial Photography for Photogrammetric Mapping, Ground Control, Aerotriangulation, Mapping, Map Accuracy, Materials to be Supplied by Contractor, and Delivery. For information purposes, the table of contents for the EPA specifications is also included

in Appendix B to provide some insight into the many items that must be considered during the contractual stage.

The engineer requesting the topographic mapping will likely provide the following information to the contracting officer to be included along with the detailed specifications:

- Location of the Project
- Areal Extent and Terrain of the Project
- Approximate Cross Section Locations
- Ground Cover Density
- Desired Accuracy and Contour Interval
- Desired Scale of Mapping
- Special Drafting Requirements
- Required Delivery Date

Normally, a 7.5 Minute USGS Quadrangle Map would be sufficient to locate the project, show the areal extent of the project, sketch in approximate section locations, and indicate the type of terrain to be covered. During the initial stage of the contract, the Hydraulic Engineer will likely walk the river reach with the surveyor to select the final cross section locations.

ASSOCIATED COSTS

This section is included to provide some understanding of the costs and cost components associated with performing field and aerial surveys to prepare topographic mapping and/or provide cross section data. There are obvious difficulties in preparing cost estimates for "generalized conditions" because almost every project has unique features that do not fit the assumed conditions. This was recognized by all of the technical people involved in preparing these estimates. However, the intent of this work is to prepare a reasonably broad range of estimates that would be useful in the planning stages of a project.

For purposes of cost estimating, a sample reach 20,000 feet long ranging in width from 200 to 2,000 feet and cross-section spacing ranging from 250 to 4,000 feet was selected (see Figure 8, Schematic for Typical Section and Reach). The type of terrain and cover are important factors in estimating costs for both aerial and field surveys. Therefore, in an effort to bracket the costs two cases were evaluated: flat terrain with light vegetative cover and steep terrain with heavy vegetative cover.

While index values are provided in Appendix D to reflect regional labor differences, insertion of local unit costs in one of the cost estimates and comparing the estimates would provide an improved index value to use with the cost curves developed for this study. These cost curves are based on January 1, 1985 costs.

The resulting quantity and cost tables are presented in Appendix C. The cost curves summarize those tables and are presented in this section after the following brief description of the field and aerial survey cost components.

Field Surveys

The field survey and hydrographic survey estimated quantities and costs for various conditions shown in Appendix C, Tables C-1 through C-7, were based on the following eight cost items:

1. Mobilization
2. Planning and Research
3. Field Surveys
 - a. Control
 - b. Cross Sections
4. Field Note Reductions
5. Data Entry
6. Checking
7. Supervision
8. Computer
9. Hydrographic Costs

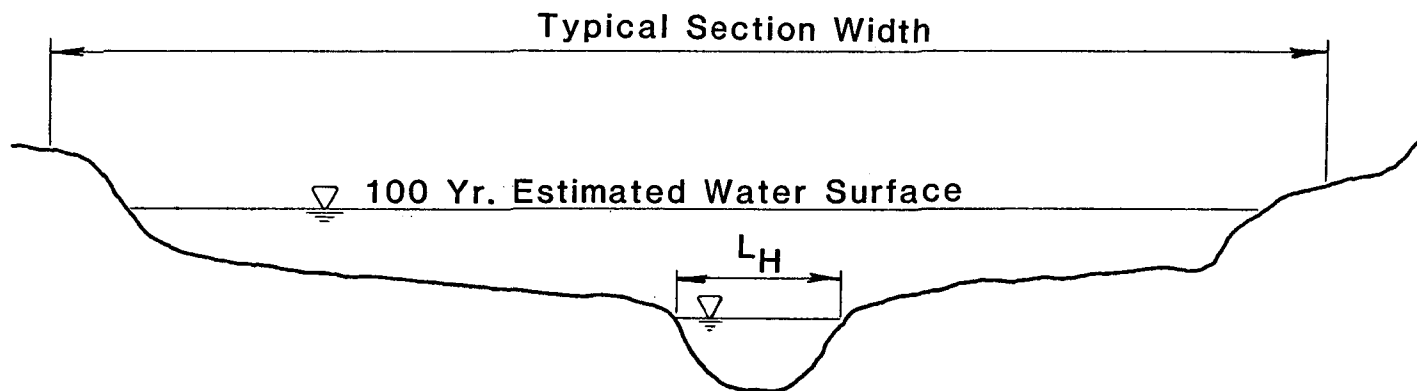

L = Section Length Of Hydrographic Survey If Required.

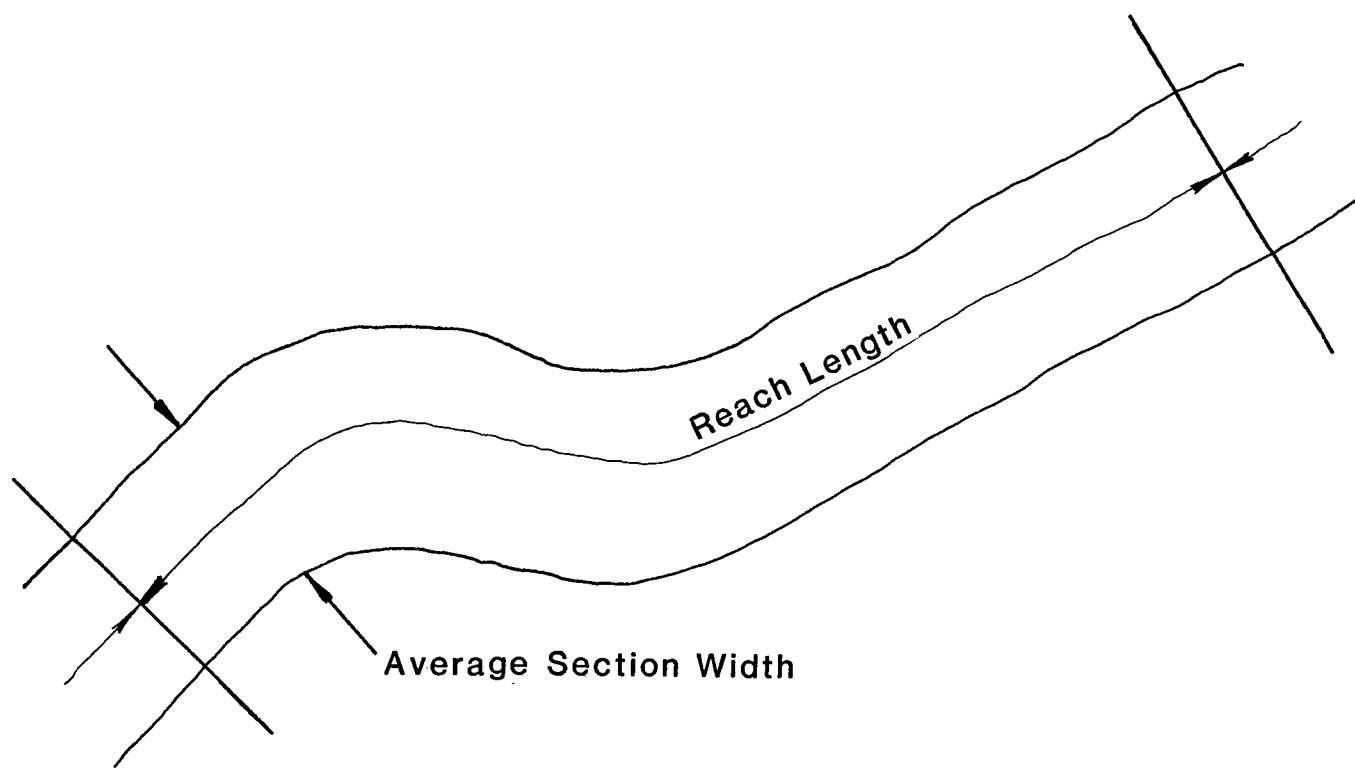

SCHEMATIC
TYPICAL SECTION AND REACH

To develop transferable quantities for the above cost items from region to region, a conversion table was prepared and is shown in Appendix C, Table C-1. It was assumed that the most common function was the three-person survey party. Using a local competitive charge out rate for a three-person crew and dividing by three, a unit man-day cost was obtained. The local fee basis for the remaining cost items was used to obtain the conversion factors. The result is that each estimate has a unit man-day figure that could be transferable to any other region once prevailing wage rates are established. The charge out rates used include overhead, employee benefits, and profit. There will obviously be some regional variation in these factors.

Mobilization and Planning Research -- Mobilization and planning research are closely linked operations which include initial meetings, preparation of cost estimates, inventory of supplies, and organization of manpower. This would involve primarily senior partner and/or principal time and some minimal crew time.

Field Surveys -- Field surveys was broken into two components -- control and cross sections. The control survey includes tying into a local benchmark and providing sufficient vertical and horizontal control points to complete the cross section work. For purposes of determining costs for surveying the cross sections, it was estimated that a three-person crew could run 120 points per day. It was assumed that a conventional level would be used for section widths up to 500 feet wide and an EDM would be used for sections wider than 500 feet. Since the section width varied from 200 to 2,000 feet, the following number of points per section were assumed:

<u>Section Width, feet</u>	<u>Number of Points</u>
200	20
500	25
1,000	30
2,000	40

Field Note Reductions -- The reduction of control survey and cross-section field notes were assumed to be performed by junior personnel. The notes would be reduced in a manner to facilitate data entry.

Data Entry -- This cost item includes the time to input the data into the HEC-2 Computer Program GR Card Format.

Checking -- Costs were provided to check the computer plotted cross sections for input errors, note reduction errors, or inconsistent field measurements.

Supervision -- Time for supervision of the field surveys, note reductions, data entry, and checking was included to control the quality of the work.

Computer Costs -- Costs were estimated to cover the computer costs incurred during data entry and plotting of the cross sections.

Hydrographic Costs -- For purposes of this study, it was assumed that a shore controlled hydrographic survey was performed with a three-person survey crew. A person on shore was used to position the boat on the cross section and the boat was equipped with a fathometer to take readings at specific time intervals along the section. The hydrographic survey quantities and cost estimates shown in Appendix C, Tables C-6 and C-7, reflect higher start-up costs than normal field surveys. Since the measurements are based on depth below the water surface, time is included to establish the water surface elevation at the time of each measurement. For large bodies of water with tidal effects, tidal boards are set. For river flow with no tidal effects sufficient water level measurements must be made to keep track of river stage changes. Once the hydrographic survey operation is set up, the cross-sectioning with a fathometer should be relatively efficient.

Aerial Surveys

For the sample reach selected, the following information was assumed:

- Mapping scale 1" = 100'
- Negative scale 1" = 500' (1" = 6000")
- Contour interval = 2'
- Six-inch focal length camera
- Average 60% forward gain = 1800'
- Average 30% side overlap = 3150'
- Eleven stereo models were used to cover the sample reach

The aerial surveys quantity and cost estimates to prepare topographic mapping and/or cross sections are separated into the following costs items:

1. Mobilization
2. Flight Planning
3. Field Surveys
 - a. Control
 - b. Fill in areas
4. Flying
5. Negatives
6. Contact Prints
7. Analytical Bridging
8. Compilation -- Topography
9. Compilation -- Section Spot Elevations
10. Drafting
11. Plates
12. Editing -- Topography
13. Editing -- Section Spot Elevations
14. Data Entry
15. Computer Costs
16. Checking Plotted Sections
17. Materials

Mobilization -- This component includes mobilizing plane, camera, and crew.

Flight Planning -- The flight pattern is normally laid out on USGS quadrangle maps. The timing of the flight is evaluated to take the photos at a high sun angle to eliminate as many shadows as possible.

Field Surveys -- Field surveys in support of aerial surveys is separated into two categories -- horizontal and vertical control surveys and field work required to fill in areas not picked up by the camera. Typically, a field survey team will coordinate with the aerial survey team to determine the number, spacing, and approximate locations of control points to meet photogrammetric requirements.

Flying -- Flying includes the flying time to and from the project site and the flying time along the preplanned flight lines.

Negatives -- Negatives of the photographs taken are prepared for use to make contact prints and to make the glass plates required for use with the plotters during compilation.

Contact Prints -- Costs for photographic prints of the flight negatives are also included.

Analytical Bridging -- This item is included to cover costs to bridge together a minimum number of field control points mathematically to meet the photogrammetric requirements for the desired mapping scale and accuracy.

Compilation -- This item was divided into two components to keep the costs to prepare topographic maps and to prepare cross-section spot elevations separate.

Drafting -- Typically the features drawn by the plotters are redrawn by hand onto a reproducible material, chronaflex, for use in making copies.

Plates -- These are glass plates made from the flight negatives that are used with the plotters during the compilation process.

Editing -- Editing the topographic maps and cross-section spot elevations is included to minimize errors.

Data Entry -- Time to enter the data into a computer in the HEC-2 Computer Program GR Card Format is covered under this cost item.

Computer Costs -- The computer costs to cover data entry and plotting of cross sections are also included.

Checking Plotted Cross Sections -- Costs are included to cover the checking of plotted sections for input errors and any inconsistent section points.

Materials -- An allowance to cover the costs for the materials used in preparing the final maps and cross sections was made and included in the cost tables.

The resulting cost tables, Tables C-8 through C-15, for aerial surveys are included in Appendix C.

Cost Curves

Cost curves for field and aerial surveys and hydrographic surveys were prepared. The curves cover a broad range of terrain and vegetative cover conditions, including flat terrain and light cover to steep terrain and heavy cover. The cost curves shown on Figure 9 through Figure 16 summarize the range of cost estimates prepared and presented in Appendix C. The preparation of these curves were keyed to total costs and costs per section versus number of cross sections for the sample reach. On Figures 9, 11, 12, and 14 the bottom graphs represent costs for providing cross sections only, by field and aerial surveys, while the top graphs represent aerial survey costs to provide topography and cross sections. The top and bottom graphs

SAMPLE REACH

L=20,000 FT. W=200 FT.-2,000 FT.

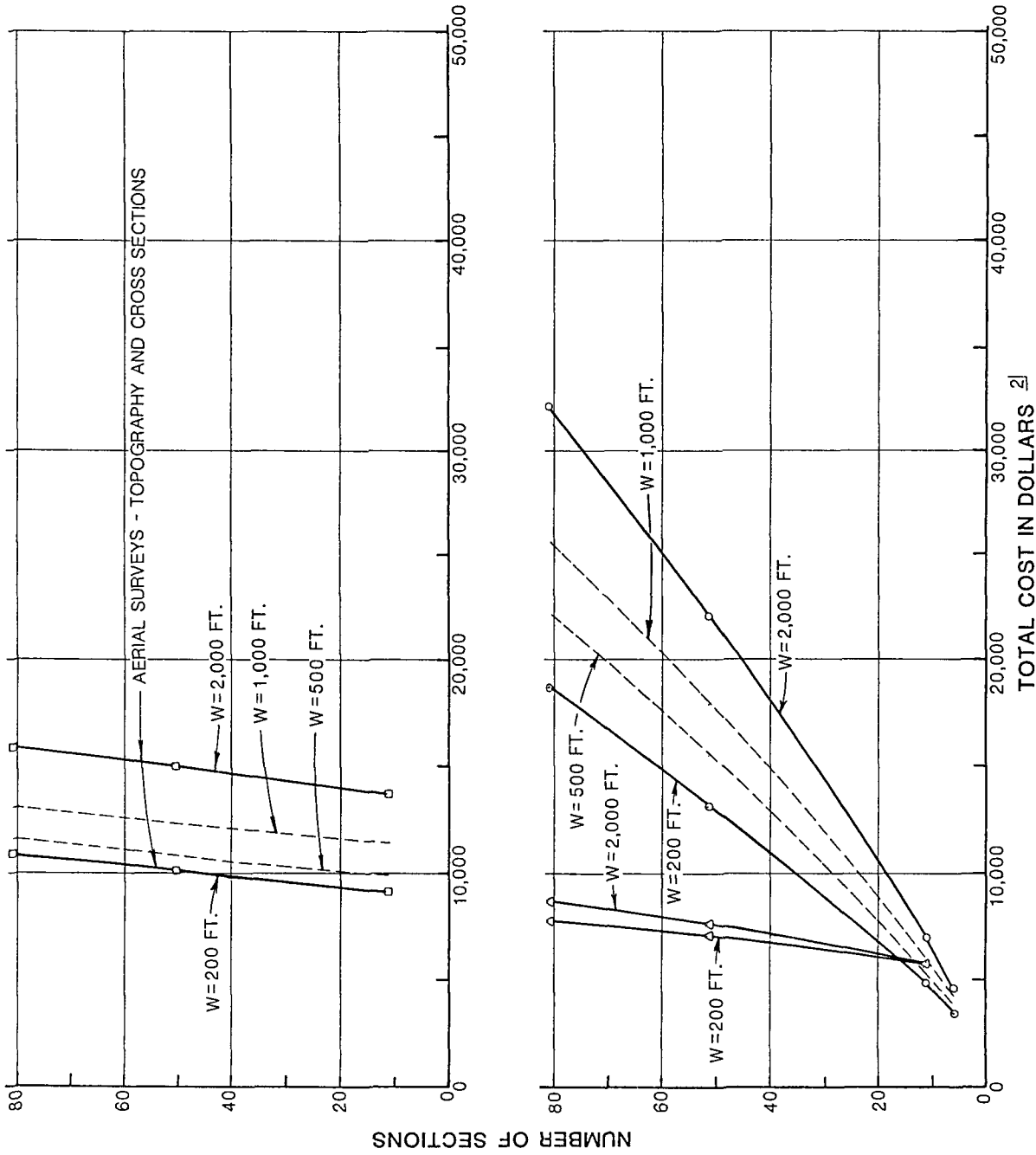

LEGEND

- FIELD SURVEYS - CROSS SECTIONS ONLY
 - AERIAL SURVEYS - CROSS SECTIONS ONLY
 - AERIAL SURVEYS - TOPOGRAPHY AND CROSS SECTIONS]]
-] SCALE: 1"=100',
CONTOUR INTERVAL=2'

2] JAN. 1, 1985 COSTS

**FIELD AND AERIAL SURVEYS
COST INFORMATION
FLAT, LIGHT-COVER CASE**

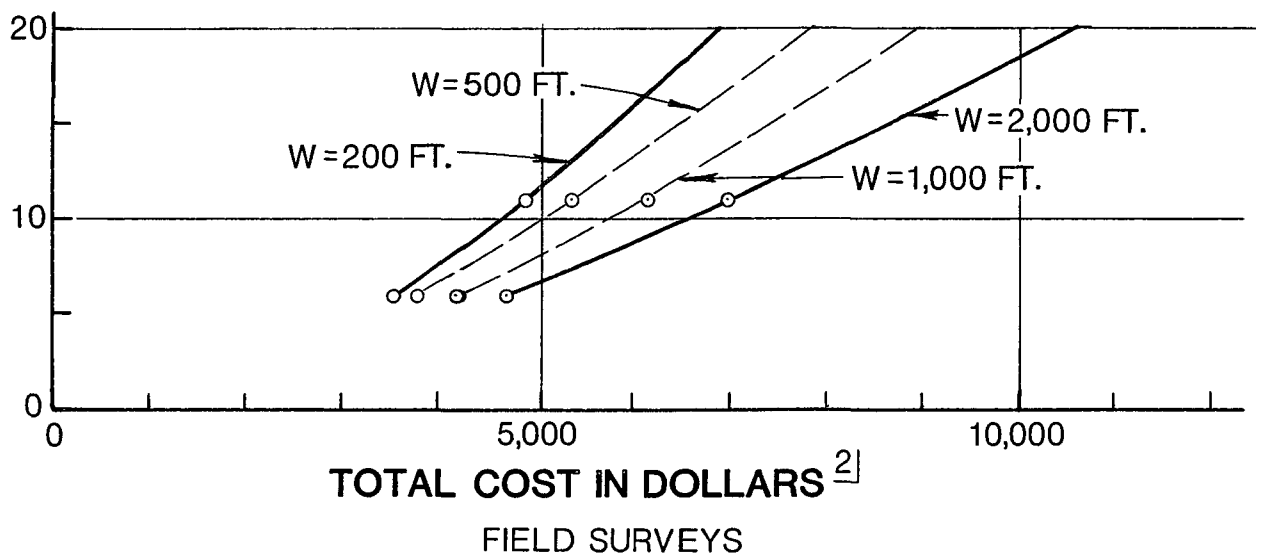
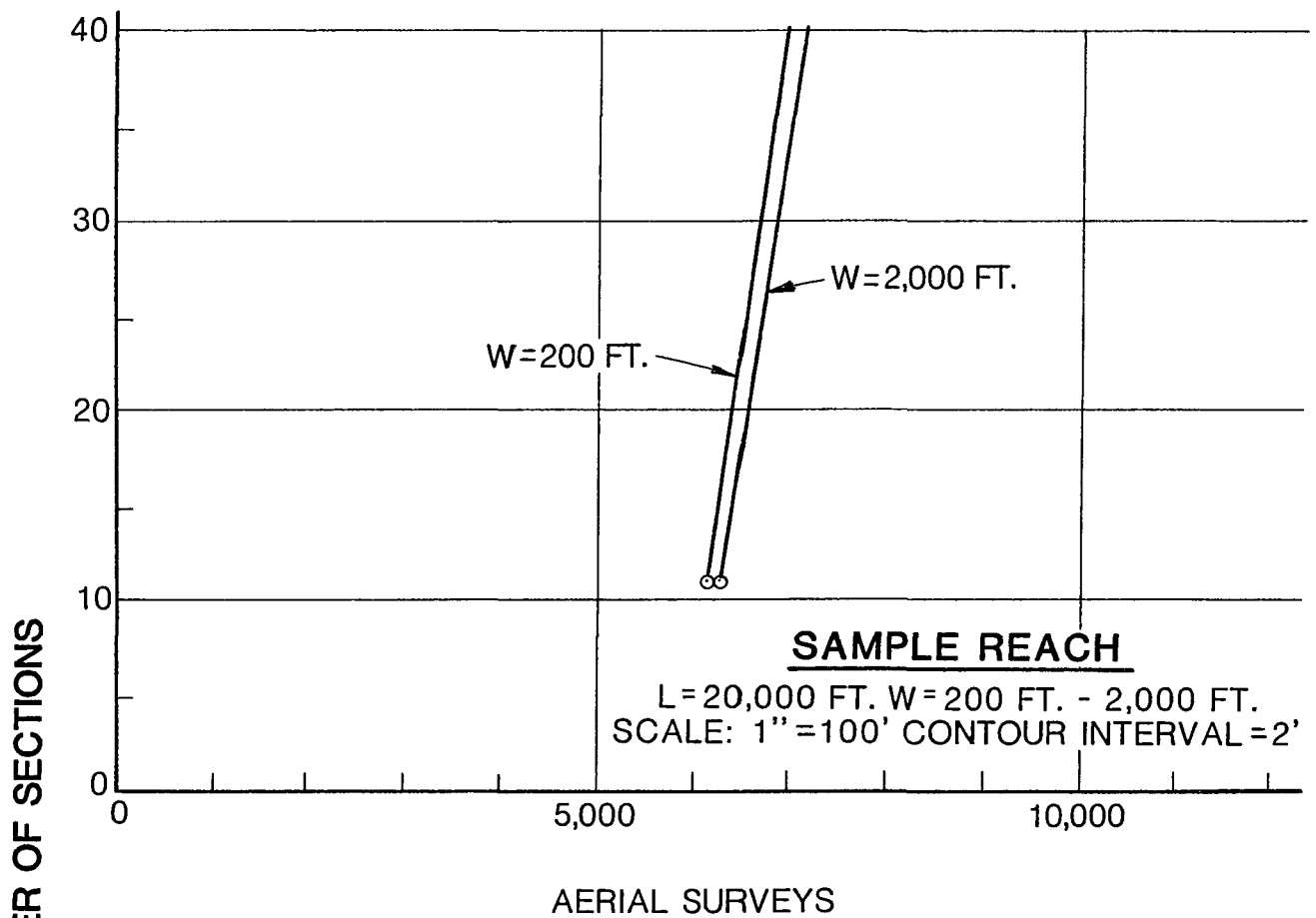

^{2]} JAN. 1, 1985 COSTS

FIELD AND AERIAL SURVEYS
COST INFORMATION - CROSS SECTIONS ONLY
FLAT, LIGHT-COVER CASE

SAMPLE REACH

L=20,000 FT. W=200 FT.-2,000 FT.

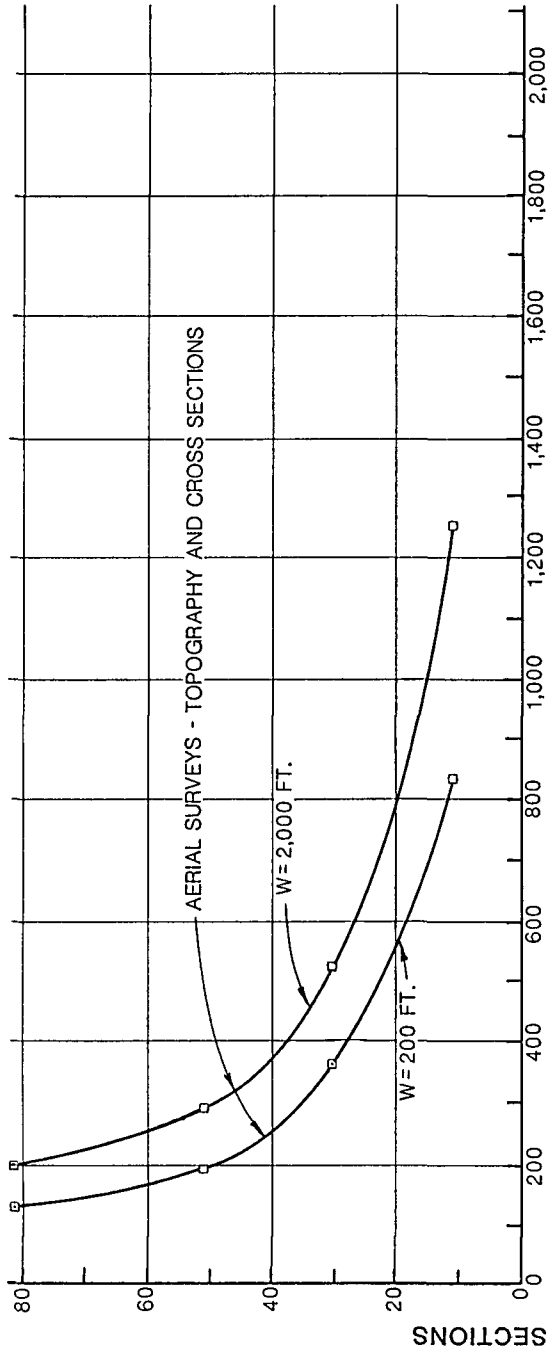

LEGEND

- FIELD SURVEYS - CROSS SECTIONS ONLY
- △—△ AERIAL SURVEYS - CROSS SECTIONS ONLY
- AERIAL SURVEYS - TOPOGRAPHY AND CROSS SECTIONS 1]

1] SCALE: 1" = 100'
CONTOUR INTERVAL = 2'

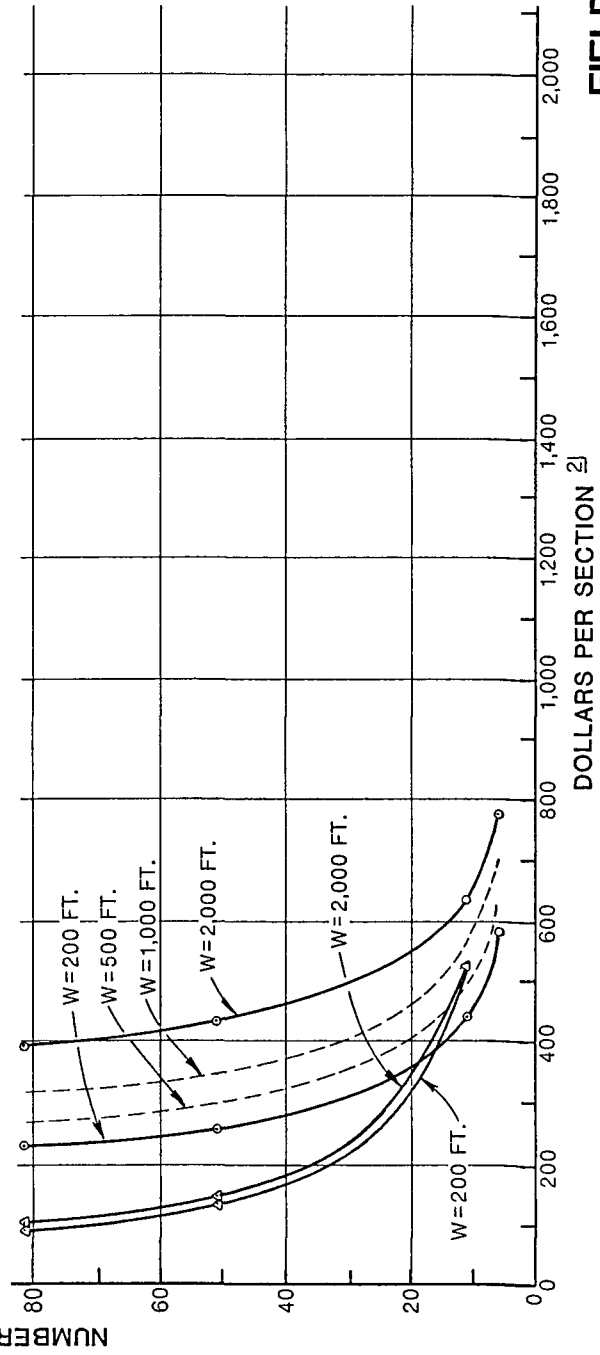

2] JAN. 1, 1985 COSTS

**FIELD AND AERIAL SURVEYS
COST PER SECTION
FLAT, LIGHT-COVER CASE**

SAMPLE REACH
 L=20,000 FT. W=200 FT.-2,000 FT.

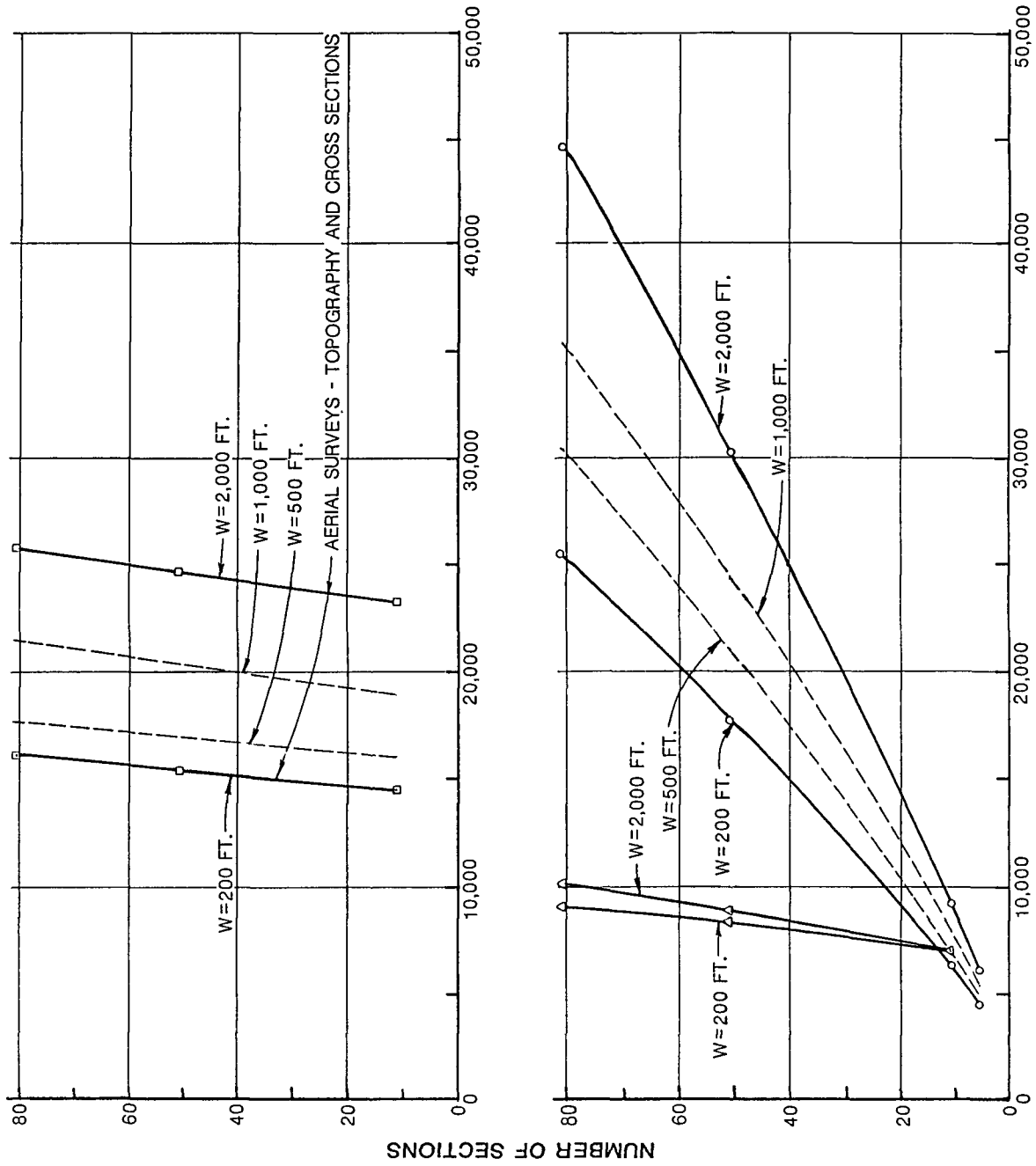

LEGEND

- — FIELD SURVEYS - CROSS SECTIONS ONLY
- — AERIAL SURVEYS - CROSS SECTIONS ONLY
- — AERIAL SURVEYS - TOPOGRAPHY AND CROSS SECTIONS 1]

1] SCALE: 1" = 100';
 CONTOUR INTERVAL = 2'

FIELD AND AERIAL SURVEYS
COST INFORMATION
STEEP, HEAVY-COVER CASE

2] JAN. 1, 1985 COSTS

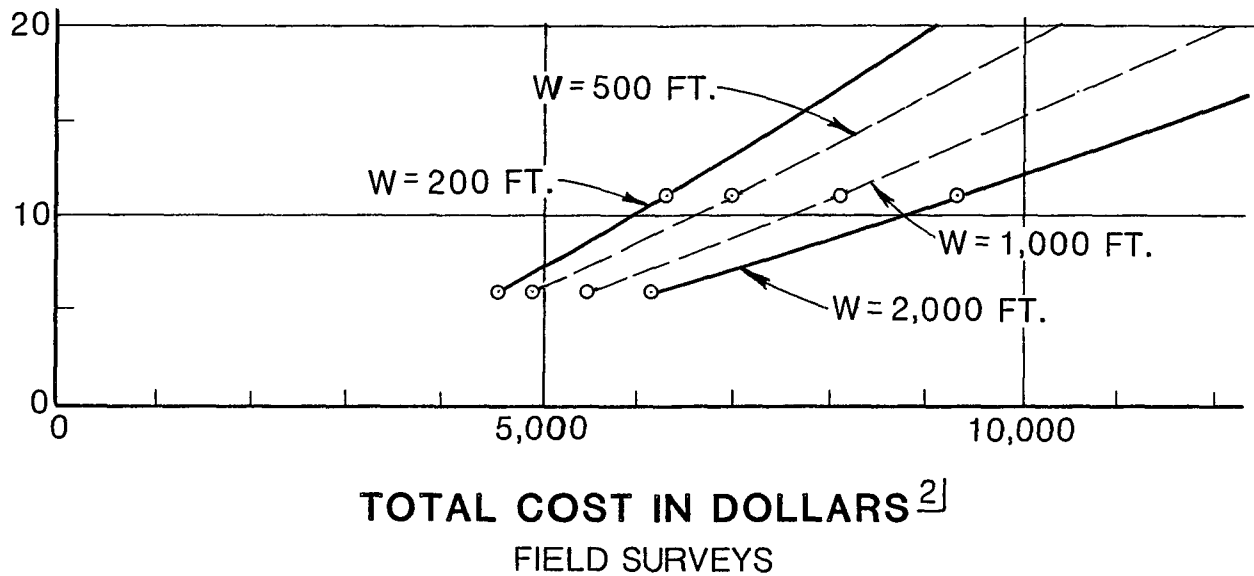
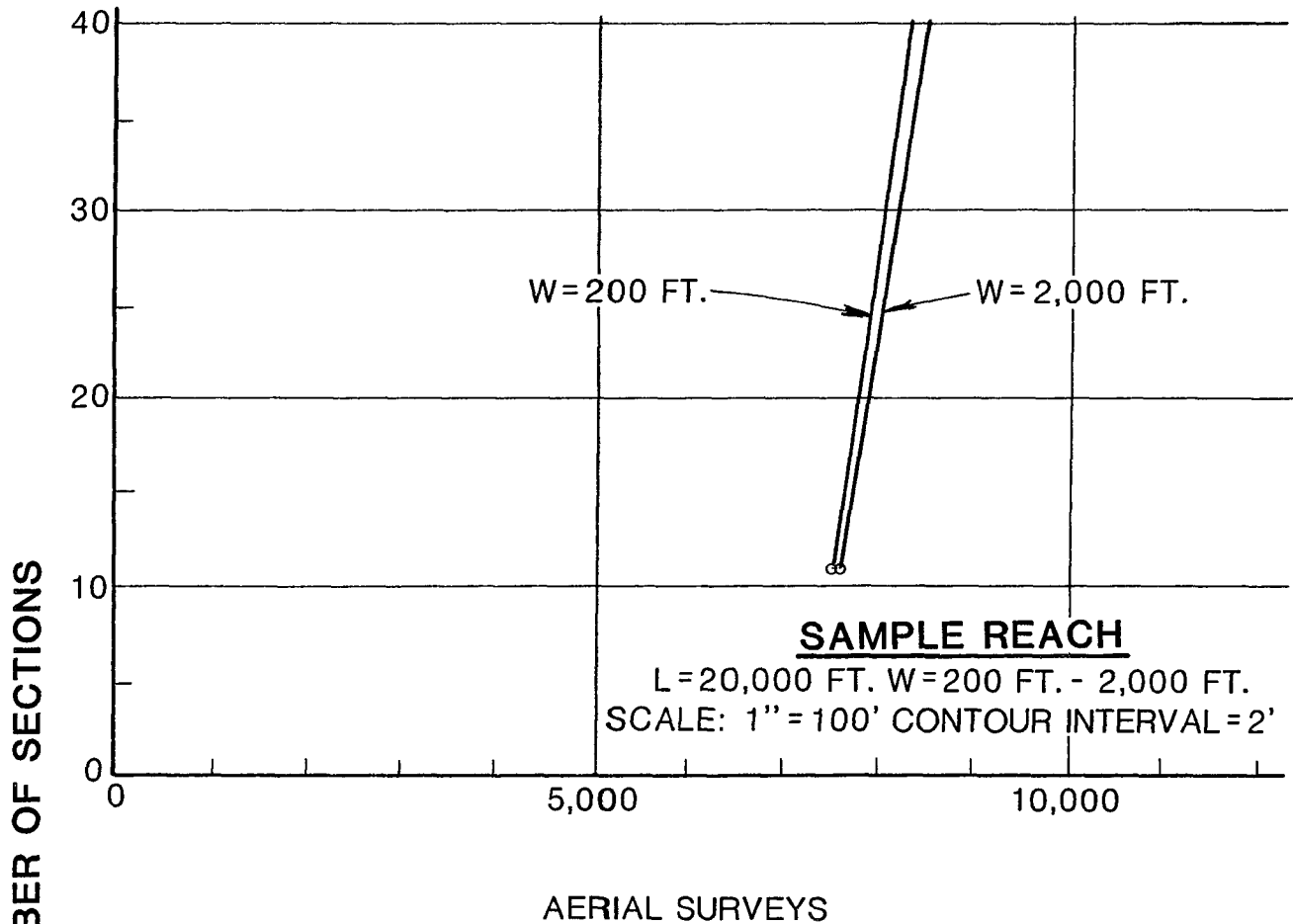

^{2]} JAN. 1, 1985 COSTS

FIELD AND AERIAL SURVEYS
COST INFORMATION - CROSS SECTIONS ONLY
STEEP, HEAVY-COVER CASE

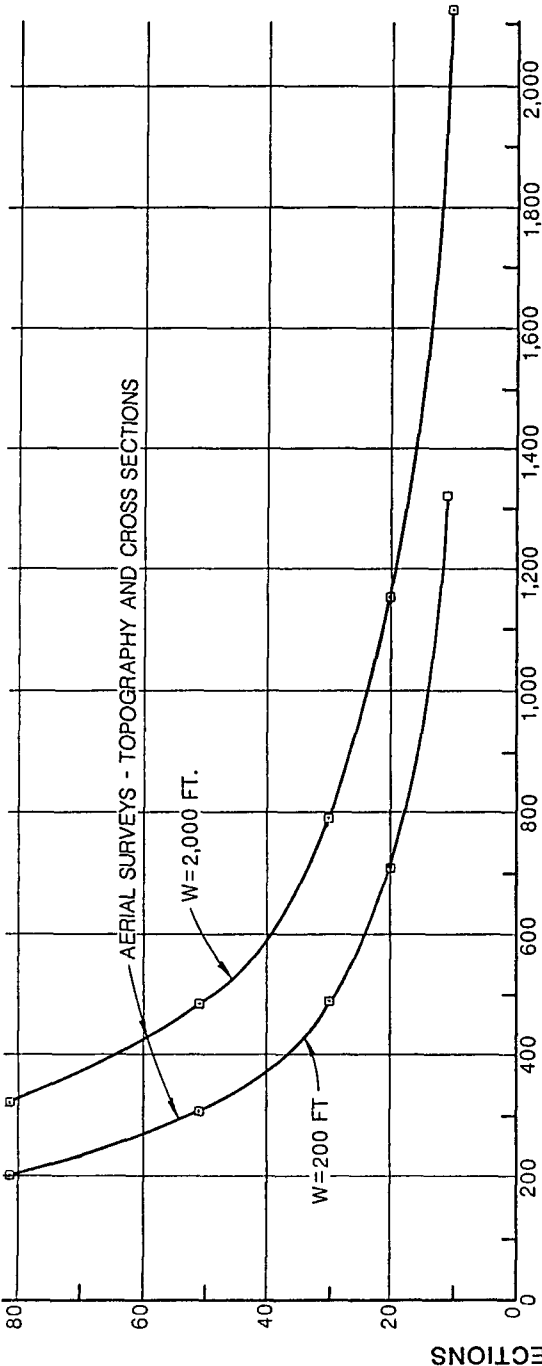

SAMPLE REACH
 L=20,000 FT. W=200 FT.-2,000 FT.

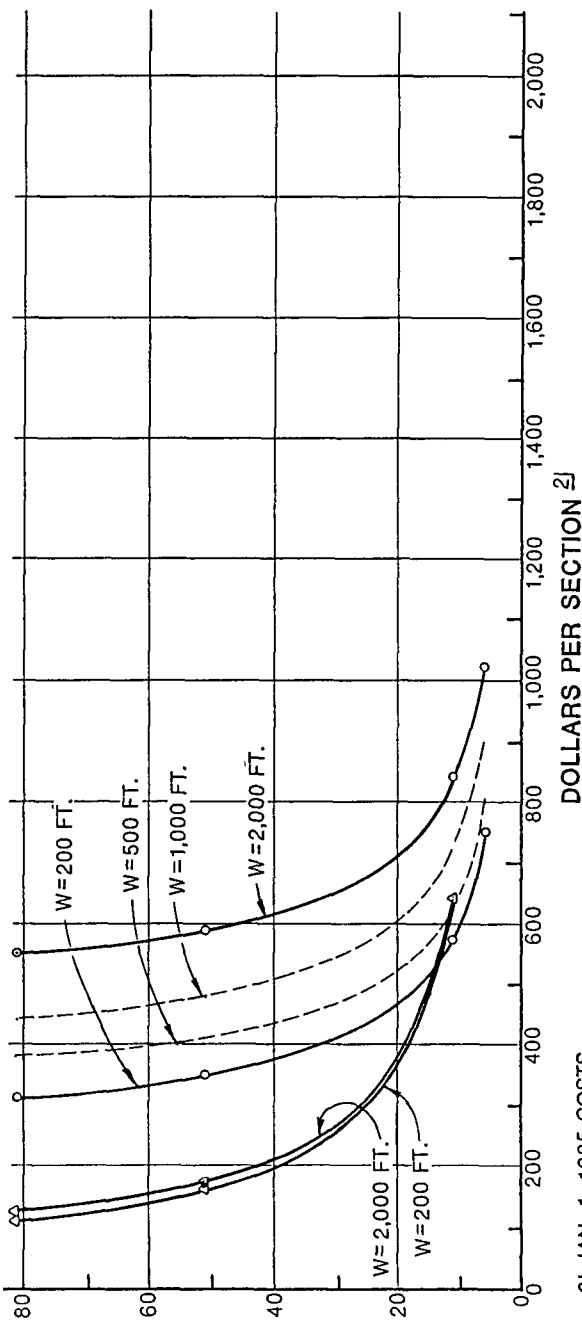

LEGEND

- FIELD SURVEYS - CROSS SECTIONS ONLY
 - AERIAL SURVEYS - CROSS SECTIONS ONLY
 - AERIAL SURVEYS - TOPOGRAPHY AND CROSS SECTIONS 1]
- 1] SCALE: 1" = 100';
 CONTOUR INTERVAL = 2'

**FIELD AND AERIAL SURVEYS
 COST PER SECTION
 STEEP, HEAVY-COVER CASE**

2] JAN. 1, 1985 COSTS

HYDROGRAPHIC SURVEYS
COST INFORMATION

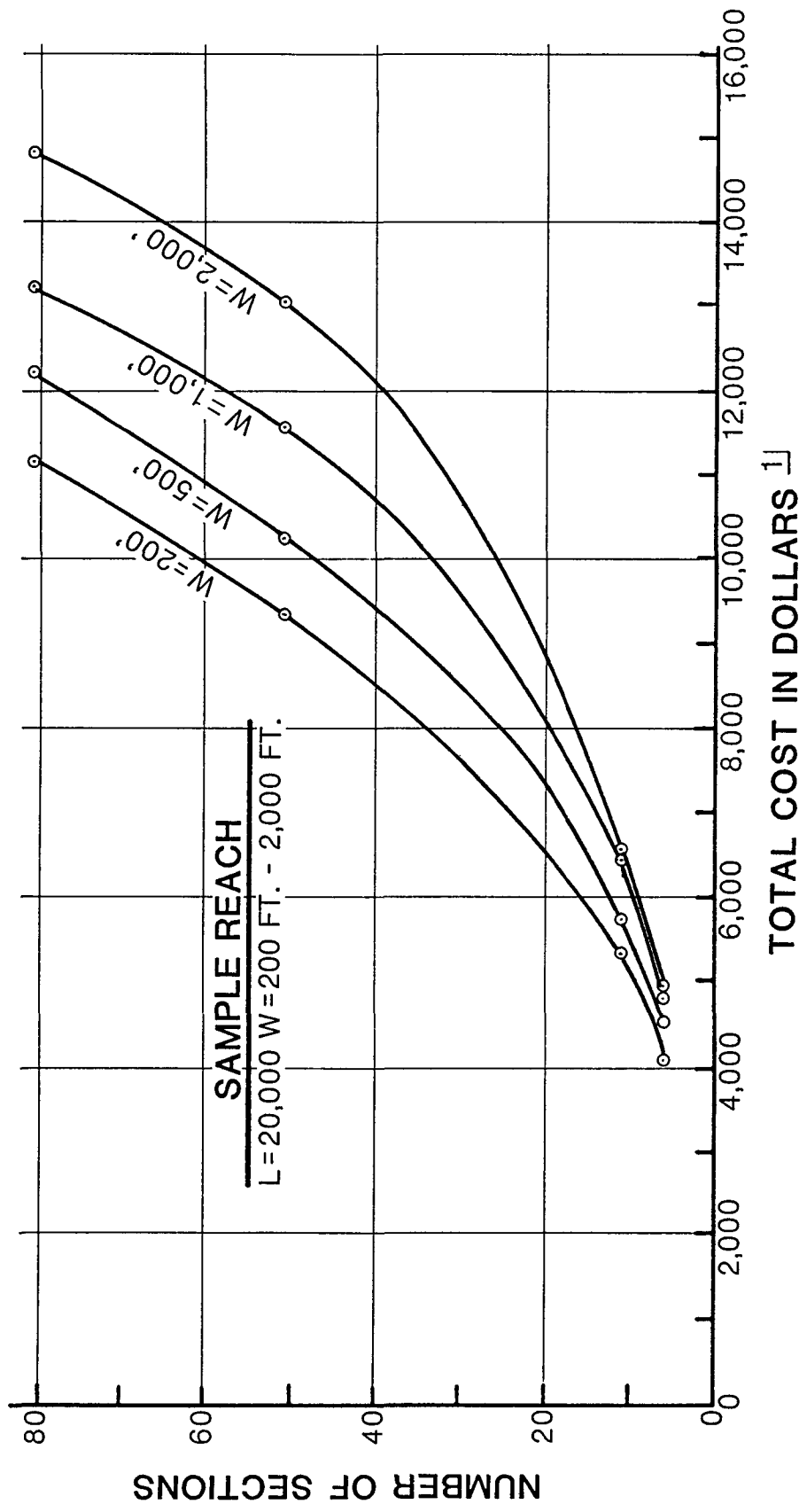

1] JAN. 1, 1985 COSTS

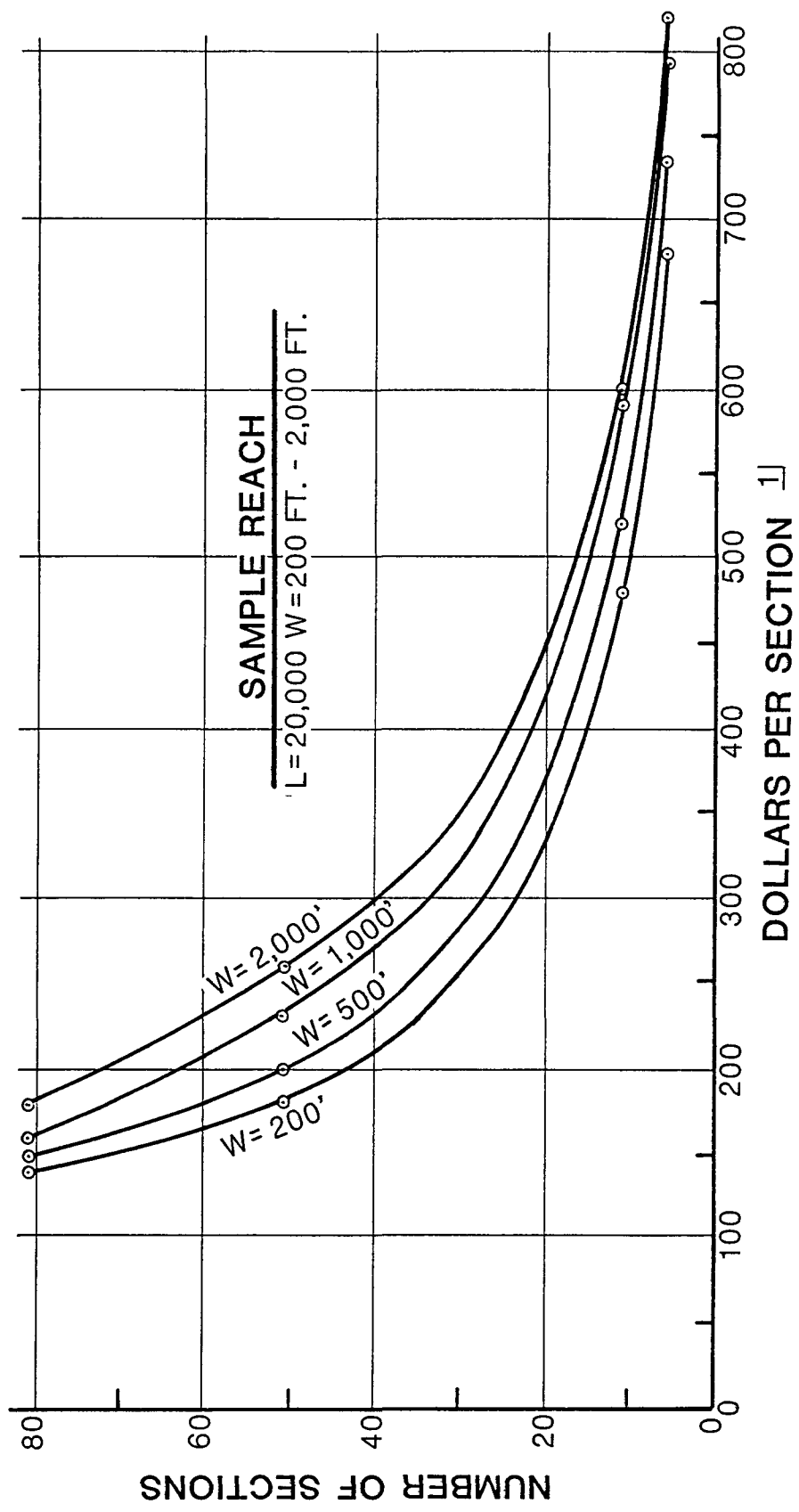

1] JAN. 1, 1985 COSTS

HYDROGRAPHIC SURVEYS
COST PER SECTION

are plotted to the same vertical and horizontal scales to facilitate cost comparisons.

Typically, the locations and number of sections selected are keyed to hydraulic considerations to provide a simulation of discharge versus stages within an acceptable level of accuracy. The sensitivity information shown on the cost curves should provide some insight into adding or deleting sections to meet various levels of accuracy.

Figures 10 and 13 are expanded portions of cost curves of Figures 9 and 12 for projects with less than 20 surveyed cross sections required. It is likely that the selection of field or aerial surveys in this range will be dictated by factors other than costs.

The aerial survey costs presented are keyed to a mapping scale of 1" = 100' and a contour interval of 2'. For information purposes, costs to provide the same services for 1" = 200' mapping with a contour interval of 5' would be about 30-50 percent of those estimated for the 1" = 100' mapping scale. For more detailed mapping of 1" = 50' with a contour interval of 1', the costs would be 150-200 percent of those presented for the 1" = 100' mapping case.

Example Comparisons

This section is included to illustrate the use of the cost information presented on Figures 9 through 16.

Example 1:

Given: Reach Length = 15,000 feet
Approximate floodplain section width = 1,500 feet
River width at normal water surface = 200 feet
Steep, heavy-cover case
Approximate section spacing = 250 feet

Since reach length is different than the sample reach, the cost per section curves on Figure 14 are used. From the given information, the cross section width beyond the water surface is approximately 1,300 feet. The number of sections required is about 60. From Figures 14 and 16 at 60 sections, the following costs for field surveys and aerial surveys are estimated.

	<u>Field Surveys</u>		<u>Aerial Surveys</u>	
	<u>\$/Section</u>	<u>Costs</u> \$	<u>\$/Section</u>	<u>Costs</u> \$
Overbank to water line @ w = 1,300'	480	28,800	150	9,000
Hydrographic surveys @ w = 200'	165	<u>9,900</u>	165	<u>9,900</u>
Estimated Costs		38,700		18,900

Example 2:

Given: Reach length = 10,000 feet
 Approximate floodplain section width = 600
 River width at normal water surface = 300
 Flat, light cover case
 Approximate section spacing = 700 feet

Since reach length is different than sample reach use the cost per section curves on Figures 11 and 16. For the given information, the cross section width beyond the water surface is approximately 300 feet. The number of sections required is about fifteen. From Figures 11 and 16 at fifteen sections, the following costs for field surveys and aerial surveys are estimated:

	<u>Field Surveys</u>		<u>Aerial Surveys</u>	
	<u>\$/Section</u>	<u>Costs</u> \$	<u>\$/Section</u>	<u>Costs</u> \$
Overbank to waterline @ w = 300'	410	6,150	410	6,150
Hydrographic surveys @ w = 300'	420	<u>6,300</u>	420	<u>6,300</u>
Estimated Costs		12,450		12,450

SURVEY SELECTION CONSIDERATIONS

There are a number of items that should be considered before deciding on the acquisition of cross-section data for a specific project. Some of these items are listed below:

- Other Project Field Data Needs
- Available Data
- Size of Project
- Location of Project
- Time Schedule
- Available Staff
- Required Accuracy
- Terrain and Vegetative Cover
- Alternative Costs

Other Project Field Data Needs

Normally when a new project is being initiated, the Project Manager will develop a list of activities along with a schedule to complete the project. There will likely be other field data needs in addition to the cross-section data required to perform the water surface profile calculations. For example, if an access road is a required component of the project, then alternative alignments will have to be evaluated. If field surveys or topographic mapping are required to complete the evaluation and design of that facility, it would be expedient to acquire the cross-section data at the same time by selecting the most cost-effective approach to satisfy all of the field data needs.

Available Data

The time spent during the initial phases of a study locating the available data that could be useful for a specific project can be very cost-effective. Often topography or cross-section data has been developed for

various purposes for other projects. The extent or scale of the data may not be sufficient to cover all of the data requirements, however, costs for supplemental field surveys or aerial surveys could be significantly less than the costs for a completely new field data acquisition program.

Project Size

The size of the project may preclude using field surveys or aerial surveys. An extremely small project with only a limited number of cross sections required would likely be best accomplished by field surveys. Aerial surveys would be more suitable for large project areas with many cross sections required.

Location of the Project

The location of a project can be an important consideration in selecting the approximate survey method to acquire cross-section data. An extremely remote project area with difficult access would favor aerial surveys trying to minimize the time required by field staff.

Time Schedule

The schedule of a particular project might dictate the survey method required. The decision on an intermediate sized project that could be done economically by either survey method might be decided by the amount of time available to provide the service. In one case a short duration might favor one method while a longer duration might favor the second method. Aerial surveys may be precluded due to heavy tree cover during most of the year. However, the schedule may allow the aerial photographs to be taken during the winter months when the leaves are gone.

Available Staff

Many organizations have survey crews that could acquire the needed cross-section data on small to medium projects. If staff is not available to

perform the work then procurement of the data acquisition services by either field surveys or aerial surveys would be required.

Required Accuracy

The required accuracy of the cross-section data could affect the survey method selection process. Where a high level of accuracy is required, the field surveys would be favored. A low level of accuracy required could be accomplished by both survey methods with the selected method being decided by cost comparisons.

Terrain and Vegetative Cover

Terrain and vegetative cover are important factors in determining the costs for field or aerial surveys. Steep terrain with heavy vegetative cover will increase field survey costs compared with flatter terrain with light vegetative cover. Extremely heavy vegetative cover may preclude using aerial surveys. Areas where the camera cannot pick up the ground surface will have to be filled in with field surveys.

Alternative Costs

The selection process will probably be affected by one or more of the above-mentioned considerations along with the costs of the various alternatives to acquire the needed data. All of the above items can be important in selecting the appropriate method. It might be worthwhile during the selection process to prepare a table similar to Table 6 for each project keyed to the factors that are important to that specific project. Table 6 is included to provide the reader with an idea of the favored survey for the broad range of conditions for each of the factors shown on the table. For illustration purposes, if a project area is easily accessible, limited to a small number of cross sections, and requires accuracies of less than ± 5 feet than it appears that the field surveys would likely be more appropriate than aerial surveys.

TABLE 6

FACTORS AFFECTING SURVEY SELECTION

Factors ^{1/}	Alternatives	
	Field Surveys	Aerial Surveys ^{2/}
A. Access		
Easily accessible	X ^{3/}	
Remote		X
B. Ground Cover		
Light		X
Heavy	X	
C. Areal Extent		
Small	X	
Large		X
D. Terrain		
Flat	X	
Steep		X
E. Accuracy		
Less than ± 0.5 feet	X	
More than ± 0.5 feet		X

^{1/} Not intended to be a complete list of factors.

^{2/} With minimum field control surveys.

^{3/} Conceptually favored alternative.

REFERENCES

- (1) Thompson, Morris M., Mapping America is Never-Ending Task for USGS, Civil Engineering-ASCE, Volume 49, No. 2, February 1979, pp. 77-81.
- (2) HEC-2, Water Surface Profiles, Users Manual, January 1981.
- (3) Chow, Ven Te, Open-Channel Hydraulics, 1959, pages 98-125.
- (4) American Congress on Surveying and Mapping and the American Society of Civil Engineers, "Definitions of Surveying and Associated Terms," reprinted 1981.
- (5) Underwater Acoustics, A Brief Description, Raytheon Company, Submarine Signal Division, 1966.
- (6) Moffitt, Francis and Mikkhail, Edward; Photogrammetry, Harper & Row, Third Edition, page 1, 1980.
- (7) California Department of Transportation, verbal communication with Mr. Joe Mori, Chief, Office of Geometronics, Photogrammetry Branch, June 1985.
- (8) California Department of Transportation, Survey Manual, Chapter 4, Section 4-01, March 1976.
- (9) Engineer Topographic Laboratories, U.S. Army Corps of Engineers, "Artificial Intelligence/Robotics" newsletter.
- (10) Engineer Pamphlet 70-1-1 Oct. 1979, "Remote Sensing Application Guide" Part 2 of 3, Department of the Army Office, Chief of Engineers, Washington, D.C. 20314.
- (11) Stanford Research Institute, verbal communication, February 1985.
- (12) Department of the Interior, U.S. Geological Survey, National Mapping Division, "Flight Testing the Aerial Profiling of Terrian System," Open File Report 84-881, 1984.
- (13) The Mini-Ranger Satellite Survey System, Motorola, 1984.
- (14) Thompson, Morris M., Automation in Surveying and Mapping: Present and Future, Journal of the Surveying and Mapping Division, Proceedings of ASCE, Vol. 103, No. SU1, September, 1977, pp. 15-24.
- (15) Southard, R. B.; McLaurin, J. D.; Amos, L. L.; Anderson, K. E.; "Coordination of Federal Digital Cartographic Activities," paper presented at U.S. Army Corps of Engineers Surveying Conference, February, 1985, pp. 266-277.
- (16) U.S. Army Corps of Engineers, "Technical Requirements for Surveying and Mapping Services," 1 January 1985.
- (17) Environmental Protection Agency document, no date.

APPENDICES

APPENDIX A

GLOSSARY OF TERMS USED IN AERIAL PHOTOGRAPHY

APPENDIX A

GLOSSARY OF TERMS USED IN AERIAL PHOTOGRAPHY^{1/}

Analytical Bridging	Mathematical solution of control extension, generally done photogrammetrically with a computer.
Benchmark	Monumented vertical point.
C-Factor	This term is used to determine accuracy in map compilation. The flight altitude divided by the contour interval, determines the "C-Factor." These factors, as determined by Federal agencies and professional societies for the various type plotters, are as follows: Kelsh-Type 900, Santoni IIC & Wild B8 1500 First Order Plotters 2000
Contact Print	A photographic print that is produced by direct contact with the original negative and is at the same scale and size as the negative.
Contours	Lines of equal elevations.
Cronaflex (Mylar)	A translucent polyester material usually .004 inch thick used in drafting and for photo "reproducibles." Has dimensional stability.
Cronopaque	A white-based opaque polyester material usually .007 inch thick. Very durable and dimensionally stable.
Diapositive	Glass contact positives used in plotters.
Digitizing	Transferring horizontal and/or vertical values to a visual console, a tape punch, or a card punch for filing or interpretation.
Distortion	Image inaccuracies caused by imperfections in lenses.
DWM (DWSM)	Double weight matte (or semi-matte) photographic paper.
Enlargement	A photographic reproduction of the original negative at a scale or size that differs from the original.

^{1/} Source: Brochure from Cartwright Aerial Surveys, Inc., Sacramento, California.

Fiducial Mark	Precise marks on sides or in corners of negatives. Used in locating the photo center and to determine film shrinkage during analytical bridging.
Film Positive	(Reproducible) Sometimes called "halftones" or "screened" film positives. Used to prepare blueline copies or ozalid prints on a diazo-type printer.
First Order Plotter	A much more precise instrument than the Kelsh-type plotters. Fewer stereo models and less ground control is needed to obtain standard map accuracy.
Focal Length	Distance between lens and focal plane of camera. The shorter the distance the wider the angle and the greater the vertical displacement.
Gain	The amount of new coverage on a photograph in a line of connected photography (distance between photo centers).
Halftone Screens	Specially prepared overlay screens containing a pattern of tiny, precisely spaced dots. Used in preparing film positives with either 133-line or 65-line screen.
Horizontal Control	Certain ground points showing coordinate values or distances to control scale of map or photograph.
Kelsh Plotter	Stereoscopic plotter of projection type, much less accurate than First Order Plotters.
Kind Paper	A waterproof photographic paper. About the same weight as single weight papers. More durable. Lays flat.
Line Index	A small scale map, such as a USGS quad, with each flight line marked with beginning and end exposures and selected intermediate exposures for clarity.
Logetronics	Automatic dodging contact and reduction printers.
Manuscript	A sheet or sheets on which the compiler or plotter operator originally imprints detail with pencil or ink. An unimproved map sheet.
Model	That area covered by a pair of photos in stereo plotting.
Mosaic	A precise composite of photographs. Usually pasted to a board for copying photographically.

Negative	An original or intermediate photographic product from which any number of reproductions can be made through contact or projection printing.
Orthophoto	A photograph with the relief removed by photogrammetric methods. The end products looks like a photograph and has the accuracy of a stereo compiled map.
Overlap	The common portion covered by two consecutive photos along flight strip.
Pass Point	Supplementary control points picked in plotting and passed from model to model.
Photoplan	Screened film positive with title and margin details.
Photographic Index	Similar to, but not, a mosaic. Shows relative location of each exposure on a project.
Plan & Profile	Film positive showing a scaled photographic image and profile grid on sheet with title and margin details.
Planimetric Map	Shows roads, streams, man-made structures, but no vertical information.
Relief Displacement	Image shift on negative caused by elevation of point.
Santoni IIC Plotter	Binocular-type plotter of a higher order than a Kelsh or Wild B-8. Great bridging capability.
Scale	The ratio of a distance on the photograph or map to its corresponding distance on the ground.
Sidelap	The common portion covered by two photos on adjacent flight strips.
Spot Elevations	Plotted points that have been given precise vertical values.
Spot Index	Like a line index with the actual position of each photo plotted.
Stereo	Observing the third dimension (height) with overlapping photos.
Stereo Bridging	Setting more than one model in a plotter with three or more projectors at one time, to extend control within a strip.
SWM (SWG)	Single weight matte (or glossy) photographic paper.

Topographic Map	Containing vertical data as contours or spot elevations. Usually with all that is shown on a planimetric map as well.
Triangulation Station	Monumented horizontal point.
Vertical Control	Certain ground points showing elevations to a common datum. Usually for stereo plotting and topographic mapping.

APPENDIX B

TECHNICAL AND SPECIFICATION REQUIREMENTS

1. HYDROGRAPHIC SURVEYS - TECHNICAL REQUIRMENTS
2. PHOTOGRAMMETRIC MAPPING - SPECIFICATIONS AND REQUIREMENTS

APPENDIX B

HYDROGRAPHIC SURVEYS - TECHNICAL REQUIREMENTS

11.0 HYDROGRAPHIC SURVEYS^{1/}

11.1 General: Hydrographic surveys generally consist of the following operations:

(a) Taking soundings to determine the depth of water and character of the bottom.

(b) Locating such soundings to ensure accurate plotting.

(c) Recording and plotting depths of soundings and other related details.

(d) Operation of boats, motors, taglines, electronic recorders, and Automated Hydrographic Survey Systems.

(e) Sound judgment must be exercised in hydrographic operations to ensure the safety of the personnel employed. Problems resulting from wind, tide currents, sudden squalls, and electrical storms require a high degree of team work and sound judgment.

(f) Hydrographic scrolls and field books shall be clearly designated, referenced with sketches, elevations or hydro scrolls shall be reduced and recorded in field books.

^{1/} Excerpted from U.S. Army Corps of Engineers, Technical Requirements for Surveying and Mapping Services, 1 January 1985.

11.2 Control

11.2.1 Horizontal control must be established near the shore of the body of water in which the survey is to be made. This control may be established by traverse, triangulation, or a combination of both. It must be located so that it may be readily extended to the work area.

11.2.2 Vertical control must be established near the shoreline with benchmarks located at frequent intervals so that staff gauges may be conveniently set. Attention must be given to setting the staff gauge to the proper datum. In some locations, National Geodetic Vertical Datum (NGVD) is used; in others Mean Low Low Water (MLLW) is used.

11.2.3 The staff gauge should be set where it is protected from wave action or current and where it is not influenced by local conditions. Considerations should be given to its availability at varying river stages.

11.3 Sounding

11.3.1 The determination of the relief of the bottom of a body of water is made by sounding (measuring) the vertical distance between the water surface and the bottom. The depth of the sounding is referenced to the water level at the time of sounding and is corrected to the datum determined by the staff gauge. Before the corrected soundings can be plotted on the map their horizontal location, with reference to the shore control stations, must be determined by one of the following methods:

(a) Taking soundings from a known baseline which has been located from the control on the shore. Due care must be exercised to document location of soundings to provide for possible extensions overbank by leveling.

(b) Moving the boat at a uniform rate of speed along a known range line and taking soundings at equal intervals of time.

(c) Taking soundings from a boat at the intersection of known range lines.

(d) Reading two angles simultaneously from two fixed points on shore.

(e) Taking readings by transit and stadia from the shore.

(f) Taking soundings at known distances along a wire (tag line) stretched between stations along a known range.

(g) By the use of electronic sounding and positioning equipment.

11.3.2 The purpose of the survey, the size and shape of the body of water and other factors will determine the methods or combination of methods to be used in performing the sounding operation.

11.3.3 In water depths less than 16 feet and with low current velocities, sounding rods can be used. Use may also be made of sounding lines (lead line), with an attached lead weight, marked at intervals along the line and which are used to read the depth of the water. The line must be of a material that does not stretch appreciably, and it must be checked frequently. The weights used on sounding lines will vary depending upon the depth of the water and the velocity of current. Under certain bottom conditions, the sounding rods must be fitted with a flat surfaced shoe (usually 6 inches in diameter). Also, weights designed to prevent penetration into muddy bottoms may be required on sounding lines.

11.3.4 Signal masts usually made of wood and fitted with targets of distinctive marking may be required when the range must be seen over a long distance.

11.3.5 The use of two boats, one serving as a baseline boat and the other taking the soundings may be used. The distance along the baseline and the distance between baseline and soundings may be measured by the use of a

steel wire (tag line) fitted on reels in the boats. A right angle glass or marine sextant may be used to maintain the angle between the baseline and the line of soundings.

11.3.6 Hydrographic surveying should not be attempted without adequate boats, properly powered, approved life saving equipment, and trained crews.

11.4 Electronic Devices

11.4.1 These instruments will be operated only by experienced personnel. The accuracy of the instrument should be tested daily. A simple method of testing is by establishing a depth accurately with a lead line, then measuring the same depth with the depth recorder. Any adjustment necessary should be made in strict accordance with the Operation Manual for the particular instrument.

APPENDIX B

PHOTOGRAMMETRIC MAPPING SPECIFICATIONS AND REQUIREMENTS^{2/}

- 1.0 AERIAL PHOTOGRAPHY FOR PHOTOGRAMMETRIC MAPPING
 - 1.01 General
 - 1.02 Equipment and Materials
 - Aerial Cameras
 - Aircraft
 - Film
 - 1.03 Flight Altitude Above Ground Elevation
 - 1.04 Weather and Solar Altitude
 - 1.05 Tilt^{3/}
 - 1.06 Crab^{4/}
 - 1.07 Photography Overlap/Sidelap
 - 1.08 Photography Identification or Labeling
 - 1.09 Photo Indexes
 - 1.10 Orthophotomaps
- 2.0 GROUND CONTROL
 - 2.01 Description of Work
 - 2.02 Certified Surveyor
 - 2.03 Coordinate Systems

^{2/} Excerpted outline from Environmental Protection Agency document for information purposes to indicate the detailed nature of the specification items. No date.

^{3/} The term used to describe the angle formed between the flight line and the edge of the photograph in the direction of flight.

^{4/} The term used to described the angles formed between the photograph and horizontal level in the direction of flight and normal to the direction of flight.

- 2.04 Elevations
- 2.05 Field Notes
- 2.06 Minimum Accuracy
- 2.07 Targets
- 2.08 Stadia Elevations
- 2.09 Transfer of Records and Materials
- 2.10 Control Location Map
- 2.11 Benchmarks
- 3.0 AEROTRIANGULATION
- 4.0 MAPPING
 - 4.01 Scale and Contour Interval
 - 4.02 Projection System
 - 4.03 Vertical Datum
 - 4.04 Description of Maps
 - 4.05 Drafting Requirements
 - 4.06 Names
 - 4.07 Map Relief
 - 4.08 Map Detail
 - 4.09 Drill Hole Locations
 - 4.10 Final Map Sheets
- 5.0 MAP ACCURACY
 - 5.01 Minimum Requirements for Map Accuracy
 - 5.02 Contours
 - 5.03 Coordinate Grid Lines
 - 5.04 Horizontal Control
 - 5.05 Planimetric Features
 - 5.06 Sections

5.07 Check of Work

6.0 MATERIALS TO BE SUPPLIED BY THE CONTRACTOR

6.01 Aerial Photography

6.02 Ground Control

6.03 Aerotriangulation

6.04 Mapping

6.05 Orthophotomaps

7.0 DELIVERY

7.01 Date of Delivery

APPENDIX C

QUANTITY AND COST ESTIMATE TABLES

Field Surveys

- C-1 Unit Man-Day Conversion Factors
- C-2 Cross Sections Only, Flat, Light Cover - Quantities
- C-3 Cross Sections Only, Flat, Light Cover - Costs
- C-4 Cross Sections Only, Steep, Heavy Cover - Quantities
- C-5 Cross Sections Only, Steep, Heavy Cover - Costs

Hydrographic Surveys

- C-6 Cross Sections - Quantities
- C-7 Cross Sections - Costs

Aerial Surveys

- C-8 Topography and Cross Sections, Flat, Light Cover - Quantities
- C-9 Topography and Cross Sections, Flat, Light Cover - Costs
- C-10 Cross Sections Only, Flat, Light Cover - Quantities
- C-11 Cross Sections Only, Flat, Light Cover - Costs
- C-12 Topography and Cross Sections, Steep, Heavy Cover - Quantities
- C-13 Topography and Cross Sections, Steep, Heavy Cover - Costs
- C-14 Cross Sections Only, Steep, Heavy Cover - Quantities
- C-15 Cross Sections Only, Steep, Heavy Cover - Costs

TABLE C-1
FIELD SURVEYS
UNIT MAN-DAY CONVERSION FACTORS

	Man-Day Charge Out	Unit Man-Day Conversion Factor
1. Three man survey party	864/3	1.0
2. Two man survey party with EDM	776/2	1.35
3. Four man hydro survey party	1280/4	1.11
4. Three man hydro survey party	1120/3	1.30
5. Principal	416	1.44
6. Senior Draftsman	296	1.03
7. Draftsman	280	0.97
8. Clerical/Computer Time	200	0.69

NOTES:

1. Sacramento area prevailing rates.
2. Unit man-day includes overhead, employee benefits, and profit.
3. Each unit man-day = \$288/day.

TABLE C-2

FIELD SURVEYS

CROSS SECTIONS ONLY, FLAT, LIGHT COVER

QUANTITIES^{1/}

Items	Spacing @ 4000 Feet (6 Sections)			Spacing @ 2000 Feet (11 Sections)			Spacing @ 400 Feet (51 Sections)			Spacing @ 250 Feet (81 Sections)					
	Section Width, feet	200	500	1000	2000	Section Width, feet	200	500	1000	2000	Section Width, feet	200	500	1000	2000
1. Mobilization	0.7	1.4	1.4	1.4	1.4	1.4	1.4	2.9	2.9	2.9	2.9	2.9	2.9	2.9	2.9
2. Planning and Research	1.4	1.4	1.4	1.4	1.4	1.4	1.4	1.4	1.4	1.4	1.4	1.4	1.4	1.4	1.4
3. Field Survey ^{2/}															
-- Control	4.0	4.0	4.0	4.0	5.0	5.0	5.0	5.0	5.0	6.0	6.0	6.0	6.0	6.0	6.0
-- Cross Sections	3.0	4.5	6.0	8.3	11.0	11.0	25.5	31.9	38.3	51.0	51.0	40.5	50.6	60.8	81.0
4. Field Note Reduction	0.4	0.6	0.8	0.8	1.1	1.4	2.5	3.8	5.0	6.3	6.3	4.0	6.0	8.0	10.0
5. Data Entry	0.5	0.5	0.5	1.0	1.0	1.0	1.5	1.5	1.5	1.5	1.5	2.0	2.0	2.0	2.0
6. Checking	0.5	0.5	0.5	1.0	1.0	1.0	3.0	3.0	3.0	3.0	3.0	4.0	4.0	4.0	4.0
7. Supervision	1.4	1.4	1.4	1.4	1.4	1.4	2.9	2.9	2.9	2.9	2.9	2.9	2.9	2.9	2.9
8. Computer	0.3	0.3	0.3	0.7	0.7	0.7	1.4	1.4	1.4	1.4	1.4	1.4	1.4	1.4	1.4
Total	12.2	13.1	14.6	16.3	17.0	18.6	21.3	24.3	24.3	24.3	24.3	24.3	24.3	24.3	24.3

unit man-days

^{1/} Unit man-days.

^{2/} Three-man crew.

TABLE C-3
FIELD SURVEYS

CROSS SECTIONS ONLY, FLAT, LIGHT COVER

COSTS

Items	Spacing @ 4000 Feet (6 Sections)			Spacing @ 2000 Feet (11 Sections)			Spacing @ 400 Feet (51 Sections)			Spacing @ 250 Feet (81 Sections)			
	200	500	1000	200	500	1000	200	500	1000	200	500	1000	2000
1. Mobilization	200	200	400	400	400	400	840	840	840	840	840	840	840
2. Planning and Research	400	400	400	400	400	400	400	400	400	400	400	400	400
3. Field Survey ^{1/}													
-- Control	1,150	1,150	1,150	1,150	1,140	1,140	1,140	1,140	1,730	1,730	1,730	1,730	1,730
-- Cross Sections	860	1,090	1,300	1,580	1,990	2,390	3,170	7,340	9,190	11,030	14,690	17,510	23,330
4. Field Note Reduction	120	140	170	230	320	400	400	720	1,090	1,440	1,810	2,300	2,880
5. Data Entry	140	140	140	290	290	290	430	430	430	430	430	580	580
6. Checking	140	140	140	290	290	290	860	860	860	860	860	1,150	1,150
7. Supervision	400	400	400	400	400	400	840	840	840	840	840	840	840
8. Computer	90	90	90	200	200	200	400	400	400	400	400	400	400
Total Cost	3,500	3,750	4,190	4,880	5,350	6,130	6,990	13,270	15,490	17,970	22,000	22,240	25,750
Cost Per Section	580	630	700	780	490	560	640	260	300	350	430	230	320

^{1/} Three-man crew.

TABLE C-4
FIELD SURVEYS

CROSS SECTIONS ONLY, STEEP, HEAVY COVER
QUANTITIES^{1/}

Items	Spacing @ 4000 Feet (6 Sections)			Spacing @ 2000 Feet (11 Sections)			Spacing @ 400 Feet (51 Sections)			Spacing @ 250 Feet (81 Sections)			
	200	500	1000	200	500	1000	200	500	1000	200	500	1000	2000
1. Mobilization	0.7	0.7	1.4	1.4	1.4	1.4	1.4	2.9	2.9	2.9	2.9	2.9	2.9
2. Planning and Research	1.4	1.4	1.4	1.4	1.4	1.4	1.4	1.4	1.4	1.4	1.4	1.4	1.4
3. Field Survey ^{2/}													
-- Control	6.0	6.0	6.0	6.0	6.0	7.5	7.5	7.5	7.5	9.0	9.0	9.0	9.0
-- Cross Sections	4.5	5.6	6.8	8.3	10.4	12.4	16.5	38.3	47.9	57.4	76.5	91.2	121.5
4. Field Note Reduction	0.4	0.5	0.6	0.6	0.8	1.1	1.4	2.5	3.8	5.0	6.3	8.0	10.0
5. Data Entry	0.5	0.5	0.5	1.0	1.0	1.0	1.0	1.5	1.5	1.5	1.5	2.0	2.0
6. Checking	0.5	0.5	0.5	1.0	1.0	1.0	1.0	3.0	3.0	3.0	3.0	4.0	4.0
7. Supervision	1.4	1.4	1.4	1.4	1.4	1.4	1.4	2.9	2.9	2.9	2.9	2.9	2.9
8. Computer	0.3	0.3	0.3	0.7	0.7	0.7	0.7	1.4	1.4	1.4	1.4	1.4	1.4
Total	15.7	16.9	18.9	21.3	24.1	27.9	32.3	61.4	72.3	84.5	104.9	122.8	155.1

^{1/} Unit man-days.

^{2/} Three-man crew.

TABLE C-5

FIELD SURVEYS

CROSS SECTIONS ONLY, STEEP, HEAVY COVER

COSTS

Items	Spacing @ 4000 Feet (6 Sections)			Spacing @ 2000 Feet (11 Sections)			Spacing @ 400 Feet (51 Sections)			Spacing @ 250 Feet (81 Sections)					
	Section Width, feet			Section Width, feet			Section Width, feet			Section Width, feet					
	200	500	1000	200	500	1000	2000	200	500	1000	2000	200	500	1000	2000
1. Mobilization	200	200	400	400	400	400	400	840	840	840	840	840	840	840	840
2. Planning and Research	400	400	400	400	400	400	400	400	400	400	400	400	400	400	400
3. Field Survey ^{1/}															
-- Control	1,730	1,730	1,730	1,730	1,730	2,160	2,160	2,160	2,160	2,590	2,590	2,590	2,590	2,590	2,590
-- Cross Sections	1,300	1,640	1,940	2,390	2,980	3,590	4,750	11,030	13,780	16,550	22,030	17,510	21,860	26,270	34,990
4. Field Note Reduction	120	140	170	170	230	320	400	720	1,090	1,440	1,810	1,150	1,730	2,300	2,880
5. Data Entry	140	140	140	290	290	290	290	430	430	430	430	580	580	580	580
6. Checking	140	140	140	290	290	290	290	860	860	860	860	1,150	1,150	1,150	1,150
7. Supervision	400	400	400	400	400	400	400	840	840	840	840	840	840	840	840
8. Computer	90	90	90	200	200	200	200	400	400	400	400	400	400	400	400
Total Cost	4,520	4,880	5,410	6,270	6,920	8,050	9,290	17,680	20,800	24,350	30,200	25,460	30,390	35,370	44,670
Cost Per Section	750	810	900	1,020	630	730	840	350	410	480	590	310	380	440	550

^{1/} Three-man crew.

TABLE C-6

HYDROGRAPHIC SURVEYS

CROSS SECTIONS

QUANTITIES^{1/}

Items	Spacing @ 4000 Feet (6 Sections)			Spacing @ 2000 Feet (11 Sections)			Spacing @ 400 Feet (51 Sections)			Spacing @ 250 Feet (81 Sections)		
	Section Width, feet			Section Width, feet			Section Width, feet			Section Width, feet		
	200	500	1000	2000	200	500	1000	2000	200	500	1000	2000
1. Mobilization	2.2	2.2	2.9	2.9	2.9	2.9	2.9	3.6	3.6	3.6	3.6	3.6
2. Planning and Research	1.4	1.4	1.4	1.4	1.4	1.4	1.4	1.4	1.4	1.4	1.4	1.4
3. Field Survey ^{2/}												
-- Control	4.0	4.0	4.0	4.0	4.0	5.0	5.0	5.0	5.0	6.0	6.0	6.0
-- Cross Sections	1.3	2.2	3.3	2.6	3.9	5.2	5.6	7.8	10.4	13.3	15.5	20.0
4. Field Note Reduction	1.0	1.2	1.3	1.2	1.4	1.5	1.6	2.2	2.8	3.5	4.0	4.0
5. Data Entry	0.5	0.5	0.5	1.0	1.0	1.0	1.0	2.5	2.5	2.5	3.0	3.0
6. Checking	1.4	1.4	1.4	2.0	2.0	2.0	2.0	3.5	3.5	3.5	4.5	4.5
7. Supervision	1.4	1.4	1.4	1.4	1.4	1.4	1.4	2.9	2.9	2.9	2.9	2.9
8. Computer	1.0	1.0	1.0	2.0	2.0	2.0	2.0	3.5	3.5	3.5	4.0	4.0
Total	14.2	15.3	16.5	17.2	18.5	20.0	22.4	22.9	32.4	35.6	40.2	45.3
									38.8	42.4	45.9	51.4

^{1/} Unit man-days.

^{2/} Three-man crew.

TABLE C-7

HYDROGRAPHIC SURVEYS

CROSS SECTIONS

COSTS

Items	Spacing @ 4000 Feet (6 Sections)			Spacing @ 2000 Feet (11 Sections)			Spacing @ 400 Feet (51 Sections)			Spacing @ 250 Feet (81 Sections)					
	Section Width, feet	200	500	1000	2000	Section Width, feet	200	500	1000	2000	Section Width, feet	200	500	1000	2000
1. Mobilization	630	630	830	830	830	830	830	1,040	1,040	1,040	1,040	1,040	1,040	1,040	1,040
2. Planning and Research	400	400	400	400	400	400	400	400	400	400	400	400	400	400	400
3. Field Survey ^{1/}															
-- Control	1,150	1,150	1,150	1,150	1,140	1,140	1,140	1,140	1,140	1,730	1,730	1,730	1,730	1,730	1,730
-- Cross Sections	370	630	750	950	1,150	1,610	2,250	3,000	3,830	5,130	3,000	3,740	4,460	5,760	5,760
4. Field Note Reduction	290	350	370	370	350	460	630	810	1,010	1,180	860	1,150	1,440	1,730	1,730
5. Data Entry	150	150	150	150	290	290	290	720	720	720	860	860	860	860	860
6. Checking	400	400	400	400	580	580	1,010	1,010	1,010	1,010	1,300	1,300	1,300	1,300	1,300
7. Supervision	400	400	400	400	400	400	840	840	840	840	840	840	840	840	840
8. Computer	290	290	290	290	580	580	1,010	1,010	1,010	1,010	1,150	1,150	1,150	1,150	1,150
Total Cost	4,080	4,400	4,740	4,940	5,330	6,590	9,340	10,270	11,590	13,060	11,180	12,210	13,220	14,810	14,810
Cost Per Section	680	730	790	820	480	590	180	200	230	260	140	150	160	180	180

^{1/} Three-

TABLE C-8

AERIAL SURVEYS

TOPOGRAPHY AND CROSS SECTIONS, FLAT, LIGHT COVER

QUANTITIES

Cost Items	Unit	Spacing @ 2000 Feet (11 Sections)			Spacing @ 400 Feet (51 Sections)			Spacing @ 250 Feet (81 Sections)				
		Section Width, feet			Section Width, feet			Section Width, feet				
		200	500	1000	2000	200	500	1000	2000	200	500	1000
1. Mobilization	Hrs	2	2	2	2	2	2	2	2	2	2	2
2. Flight Planning	Hrs	10	10	10	10	10	10	10	10	10	10	10
3. Field Surveys ^{1/} -- Control	Hrs	24	24	24	24	24	24	24	24	24	24	24
4. Flying	Hrs	1.5	1.5	1.5	1.5	1.5	1.5	1.5	1.5	1.5	1.5	1.5
5. Negatives	Each	12	12	12	12	12	12	12	12	12	12	12
6. Contact Prints	Each	12	12	12	12	12	12	12	12	12	12	12
7. Analytical Bridging	Plate	12	12	12	12	12	12	12	12	12	12	12
8. Compilation (Topography)	Hrs	44	55	77	110	44	55	77	110	44	55	77
9. Compilation (Section Spot Elevations)	Hrs	15	15	16	18	18	18	20	22	22	23	35
10. Drafting	Hrs	44	55	77	110	44	55	77	110	44	55	77
11. Plates	Each	12	12	12	12	12	12	12	12	12	12	12
12. Editing (Topography)	Hrs	3	4	5	6	3	4	5	6	3	4	6
13. Editing (Section Spot Elevations)	Hrs	3	3	3	3	4	4	4	5	4	4	6
14. Data Entry	Hrs	12	12	12	12	18	18	18	18	24	24	24
15. Computer Costs	Hrs	2	2	2	2	4	4	4	4	4	4	4
16. Checking Plotted Sections	Hrs	12	12	12	12	35	35	35	35	46	46	46
17. Materials	LS	-	-	-	-	-	-	-	-	-	-	-

^{1/} Three-man crew.

TABLE C-9

AERIAL SURVEYS

TOPOGRAPHY AND CROSS SECTIONS, FLAT, LIGHT COVER

COSTS

Cost Items	Unit	Unit Cost (dollars)	Spacing @ 2000 Feet (11 Sections)			Spacing @ 400 Feet (51 Sections)			Spacing @ 250 Feet (81 Sections)					
			Section Width, feet	200	500	1000	2000	Section Width, feet	200	500	1000	2000		
1. Mobilization	Hrs	50	100	100	100	100	100	100	100	100	100	100	100	100
2. Flight Planning	Hrs	40	400	400	400	400	400	400	400	400	400	400	400	400
3. Field Surveys ^{1/} -- Control	Hrs	108	2,600	2,600	2,600	2,600	2,600	2,600	2,600	2,600	2,600	2,600	2,600	2,600
4. Flying	Hrs	175	260	260	260	260	260	260	260	260	260	260	260	260
5. Negatives	Each	20	240	240	240	240	240	240	240	240	240	240	240	240
6. Contact Prints	Each	2	20	20	20	20	20	20	20	20	20	20	20	20
7. Analytical Bridging	Plate	67	800	800	800	800	800	800	800	800	800	800	800	800
8. Compilation (Topography)	Hrs	40	1,760	2,200	3,080	4,400	1,760	2,200	3,080	4,400	1,760	2,200	3,080	4,400
9. Compilation (Section Spot Elevations)	Hrs	40	600	600	640	720	600	600	640	720	600	600	640	720
10. Drafting	Hrs	25	1,100	1,380	1,930	2,750	1,100	1,380	1,930	2,750	1,100	1,380	1,930	2,750
11. Plates	Each	18	220	220	220	220	220	220	220	220	220	220	220	220
12. Editing (Topography)	Hrs	30	90	120	150	180	90	120	150	180	90	120	150	180
13. Editing (Section Spot Elevations)	Hrs	30	90	90	90	90	120	120	120	120	120	120	120	120
14. Data Entry	Hrs	25	300	300	300	300	450	450	450	450	450	450	450	450
15. Computer Costs	Hrs	100	200	200	200	200	400	400	400	400	400	400	400	400
16. Checking Plotted Sections	Hrs	25	300	300	300	300	880	880	880	880	880	880	880	880
17. Materials	LS	-	110	150	150	200	110	150	150	200	110	150	150	200
Total Cost			9,190	9,980	11,480	13,780	10,270	11,060	12,600	14,930	10,850	11,640	13,140	15,900
Area Acres			92	230	459	918	92	230	459	918	92	230	459	918
\$/Acre			100	43	25	15	111	48	27	16	118	51	29	17
\$/Section			835	907	1,043	1,253	201	216	247	292	134	144	162	196

^{1/} Three-man crew.

TABLE C-10

AERIAL SURVEYS

CROSS SECTIONS ONLY, FLAT, LIGHT COVER

QUANTITIES

Cost Items	Unit	Spacing @ 2000 Feet (11 Sections) Section Width, feet			Spacing @ 400 Feet (51 Sections) Section Width, feet			Spacing @ 250 Feet (81 Sections) Section Width, feet					
		200	500	1000	2000	200	500	1000	2000	200	500	1000	2000
		2	2	2	2	2	2	2	2	2	2	2	2
1. Mobilization	Hrs	2	2	2	2	2	2	2	2	2	2	2	2
2. Flight Planning	Hrs	10	10	10	10	10	10	10	10	10	10	10	10
3. Field Surveys/ --- Control	Hrs	24	24	24	24	24	24	24	24	24	24	24	24
4. Flying	Hrs	1.5	1.5	1.5	1.5	1.5	1.5	1.5	1.5	1.5	1.5	1.5	1.5
5. Negatives	Each	12	12	12	12	12	12	12	12	12	12	12	12
6. Contact Prints	Each	12	12	12	12	12	12	12	12	12	12	12	12
7. Analytical Bridging	Plate	12	12	12	12	12	12	12	12	12	12	12	12
8. Compilation (Topography)	Hrs	-	-	-	-	-	-	-	-	-	-	-	-
9. Compilation (Section Spot Elevations)	Hrs	15	15	16	18	18	18	20	22	22	23	23	35
10. Drafting	Hrs	-	-	-	-	-	-	-	-	-	-	-	-
11. Plates	Each	12	12	12	12	12	12	12	12	12	12	12	12
12. Editing (Topography)	Hrs	-	-	-	-	-	-	-	-	-	-	-	-
13. Editing (Section Spot Elevations)	Hrs	3	3	3	3	4	4	4	5	4	4	4	6
14. Data Entry	Hrs	12	12	12	12	18	18	18	18	24	24	24	24
15. Computer Costs	Hrs	2	2	2	2	4	4	4	4	4	4	4	4
16. Checking Plotted Sections	Hrs	12	12	12	12	35	35	35	35	46	46	46	46
17. Materials	LS	-	-	-	-	-	-	-	-	-	-	-	-

1/ Three-man crew.

TABLE C-11

AERIAL SURVEYS

CROSS SECTIONS ONLY, FLAT, LIGHT COVER

COSTS

Cost Items	Unit	Unit Cost (dollars)	Spacing @ 2000 Feet (11 Sections)			Spacing @ 400 Feet (51 Sections)			Spacing @ 250 Feet (81 Sections)				
			Section Width, feet	200	500	1000	2000	Section Width, feet	200	500	1000	2000	
1. Mobilization	Hrs	50	100	100	100	100	100	100	100	100	100	100	100
2. Flight Planning	Hrs	40	400	400	400	400	400	400	400	400	400	400	400
3. Field Surveys ^{1/} -- Control	Hrs	108	2,600	2,600	2,600	2,600	2,600	2,600	2,600	2,600	2,600	2,600	2,600
4. Flying	Hrs	175	260	260	260	260	260	260	260	260	260	260	260
5. Negatives	Each	20	240	240	240	240	240	240	240	240	240	240	240
6. Contact Prints	Each	2	20	20	20	20	20	20	20	20	20	20	20
7. Analytical Bridging	Plate	67	800	800	800	800	800	800	800	800	800	800	800
8. Compilation (Topography)	Hrs	40	-	-	-	-	-	-	-	-	-	-	-
9. Compilation (Section Spot Elevations)	Hrs	40	600	600	640	720	720	720	800	880	880	880	1,400
10. Drafting	Hrs	25	-	-	-	-	-	-	-	-	-	-	-
11. Plates	Each	18	220	220	220	220	220	220	220	220	220	220	220
12. Editing (Topography)	Hrs	30	-	-	-	-	-	-	-	-	-	-	-
13. Editing (Section Spot Elevations)	Hrs	30	90	90	90	90	120	120	120	120	120	120	180
14. Data Entry	Hrs	25	300	300	300	300	450	450	450	450	450	450	600
15. Computer Costs	Hrs	100	200	200	200	200	400	400	400	400	400	400	400
16. Checking Plotted Sections	Hrs	25	300	300	300	300	880	880	880	880	1,150	1,150	1,150
17. Materials	LS	-	50	50	50	50	50	50	50	50	50	50	50
Total Cost			6,180	6,180	6,220	6,300	7,260	7,260	7,340	7,450	7,840	7,840	8,420
\$/Section			562	562	565	573	142	142	144	146	97	97	104

^{1/} Three-man crew.

TABLE C-12

AERIAL SURVEYS

TOPOGRAPHY AND CROSS SECTIONS, STEEP, HEAVY COVER

QUANTITIES

Cost Items	Unit	Spacing @ 2000 Feet (11 Sections)			Spacing @ 400 Feet (51 Sections)			Spacing @ 250 Feet (81 Sections)					
		200	500	1000	2000	200	500	1000	2000	200	500	1000	2000
1. Mobilization	Hrs	2	2	2	2	2	2	2	2	2	2	2	2
2. Flight Planning	Hrs	10	10	10	10	10	10	10	10	10	10	10	10
3. Field Surveys ^{1/} -- Control -- Fill in Areas	Hrs	36	36	36	36	36	36	36	36	36	36	36	36
	Hrs	24	24	24	24	24	24	24	24	24	24	24	24
4. Flying	Hrs	1.5	1.5	1.5	1.5	1.5	1.5	1.5	1.5	1.5	1.5	1.5	1.5
5. Negatives	Each	12	12	12	12	12	12	12	12	12	12	12	12
6. Contact Prints	Each	12	12	12	12	12	12	12	12	12	12	12	12
7. Analytical Bridging	Plate	12	12	12	12	12	12	12	12	12	12	12	12
8. Compilation (Topography)	Hrs	66	88	132	198	66	88	132	198	66	88	132	198
9. Compilation (Section Spot Elevations)	Hrs	15	15	16	18	18	20	22	22	22	23	35	35
10. Drafting	Hrs	66	88	132	198	66	88	132	198	66	88	132	198
11. Plates	Each	12	12	12	12	12	12	12	12	12	12	12	12
12. Editing (Topography)	Hrs	3	4	5	6	3	4	5	6	3	4	5	6
13. Editing (Section Spot Elevations)	Hrs	3	3	3	3	4	4	5	5	4	4	6	6
14. Data Entry	Hrs	12	12	12	12	18	18	18	18	24	24	24	24
15. Computer Costs	Hrs	2	2	2	2	4	4	4	4	4	4	4	4
16. Checking Plotted Sections	Hrs	12	12	12	12	35	35	35	35	46	46	46	46
17. Materials	LS	-	-	-	-	-	-	-	-	-	-	-	-

^{1/} Three-man crew.

TABLE C-13

AERIAL SURVEYS

TOPOGRAPHY AND CROSS SECTIONS ONLY, STEEP, HEAVY COVER

COSTS

Cost Items	Unit	Unit Cost (dollars)	Spacing @ 2000 Feet (11 Sections)			Spacing @ 400 Feet (51 Sections)			Spacing @ 250 Feet (81 Sections)		
			Section Width, feet	200	500	1000	2000	Section Width, feet	200	500	1000
(dollars)											
1. Mobilization	Hrs	50	100	100	100	100	100	100	100	100	100
2. Flight Planning	Hrs	40	400	400	400	400	400	400	400	400	400
3. Field Surveys ^{1/} -- Controls -- Fill in Areas	Hrs	108	3,900	3,900	3,900	3,900	3,900	3,900	3,900	3,900	3,900
	Hrs	108	2,600	2,600	2,600	2,600	2,600	2,600	2,600	2,600	2,600
4. Flying	Hrs	175	260	260	260	260	260	260	260	260	260
5. Negatives	Each	20	240	240	240	240	240	240	240	240	240
6. Contact Prints	Each	2	20	20	20	20	20	20	20	20	20
7. Analytical Bridging	Plate	67	800	800	800	800	800	800	800	800	800
8. Compilation (Topography)	Hrs	40	2,640	3,520	5,280	7,920	3,520	5,280	7,920	2,640	3,520
9. Compilation (Section Spot Elevations)	Hrs	40	600	640	640	640	800	880	880	880	920
10. Drafting	Hrs	25	1,650	2,200	3,300	4,950	1,650	2,200	3,300	1,650	2,200
11. Plates	Each	18	220	220	220	220	220	220	220	220	220
12. Editing (Topography)	Hrs	30	90	120	150	180	90	120	150	180	180
13. Editing (Section Spot Elevations)	Hrs	30	90	90	90	90	120	120	120	120	180
14. Data Entry	Hrs	25	300	300	300	300	450	450	450	600	600
15. Computer Costs	Hrs	100	200	200	200	200	400	400	400	400	400
16. Checking Plotted Sections	Hrs	25	300	300	300	300	880	880	880	1,150	1,150
17. Materials	LS	-	110	150	150	200	110	150	150	150	200
Total Cost			14,520	16,020	18,950	23,320	15,600	17,180	20,180	16,180	17,720
Area Acres			92	230	459	918	92	230	459	918	918
\$/Acre			158	70	41	25	170	75	44	27	176
\$/Section			1,320	1,456	1,722	2,120	306	337	396	200	219

^{1/} Three-man crew.

TABLE C-14

AERIAL SURVEYS

CROSS SECTIONS ONLY, STEEP, HEAVY COVER

QUANTITIES

Cost Items	Unit	Spacing @ 2000 Feet (11 Sections)			Spacing @ 400 Feet (51 Sections)			Spacing @ 250 Feet (81 Sections)				
		Section width, feet			Section width, feet			Section width, feet				
		200	500	1000	2000	200	500	1000	2000	200	500	1000
1. Mobilization	Hrs	2	2	2	2	2	2	2	2	2	2	2
2. Flight Planning	Hrs	10	10	10	10	10	10	10	10	10	10	10
3. Field Surveys/ -- Control	Hrs	36	36	36	36	36	36	36	36	36	36	36
4. Flying	Hrs	1.5	1.5	1.5	1.5	1.5	1.5	1.5	1.5	1.5	1.5	1.5
5. Negatives	Each	12	12	12	12	12	12	12	12	12	12	12
6. Contact Prints	Each	12	12	12	12	12	12	12	12	12	12	12
7. Analytical Bridging	Plate	12	12	12	12	12	12	12	12	12	12	12
8. Compilation (Topography)	Hrs	-	-	-	-	-	-	-	-	-	-	-
9. Compilation (Section Spot Elevations)	Hrs	15	15	16	18	20	22	22	22	22	23	35
10. Drafting	Hrs	-	-	-	-	-	-	-	-	-	-	-
11. Plates	Each	12	12	12	12	12	12	12	12	12	12	12
12. Editing (Topography)	Hrs	-	-	-	-	-	-	-	-	-	-	-
13. Editing (Section Spot Elevations)	Hrs	3	3	3	3	4	5	5	4	4	6	6
14. Data Entry	Hrs	12	12	12	18	18	18	18	24	24	24	24
15. Computer Costs	Hrs	2	2	2	4	4	4	4	4	4	4	4
16. Checking Plotted Sections	Hrs	12	12	12	35	35	35	35	46	46	46	46
17. Materials	LS	-	-	-	-	-	-	-	-	-	-	-

1/ Three-man crew.

TABLE C-15

AERIAL SURVEYS

CROSS SECTIONS ONLY, STEEP, HEAVY COVER

COSTS

Cost Items	Unit	Unit Cost (dollars)	Spacing @ 2000 Feet (11 Sections)			Spacing @ 400 Feet (51 Sections)			Spacing @ 250 Feet (81 Sections)		
			Section Width, feet			Section Width, feet			Section Width, feet		
			200	500	1000	200	500	1000	200	500	1000
----- (dollars) -----											
1. Mobilization	Hrs	50	100	100	100	100	100	100	100	100	100
2. Flight Planning	Hrs	40	400	400	400	400	400	400	400	400	400
3. Field Surveys/ -- Control	Hrs	108	3,900	3,900	3,900	3,900	3,900	3,900	3,900	3,900	3,900
4. Flying	Hrs	175	260	260	260	260	260	260	260	260	260
5. Negatives	Each	20	240	240	240	240	240	240	240	240	240
6. Contact Prints	Each	2	20	20	20	20	20	20	20	20	20
7. Analytical Bridging	Plate	67	800	800	800	800	800	800	800	800	800
8. Compilation (Topography)	Hrs	40	-	-	-	-	-	-	-	-	-
9. Compilation (Section Spot Elevations)	Hrs	40	600	640	640	720	800	880	880	920	1,400
10. Drafting	Hrs	25	-	-	-	-	-	-	-	-	-
11. Plates	Each	18	220	220	220	220	220	220	220	220	220
12. Editing (Topography)	Hrs	30	-	-	-	-	-	-	-	-	-
13. Editing (Section Spot Elevations)	Hrs	30	90	90	120	120	150	150	150	180	180
14. Data Entry	Hrs	25	300	300	300	450	450	450	450	600	600
15. Computer Costs	Hrs	100	200	200	200	400	400	400	400	400	400
16. Checking Plotted Sections	Hrs	25	300	300	300	880	880	880	880	1,150	1,150
17. Materials	LS	-	50	50	50	50	50	50	50	50	50
Total Cost			7,480	7,520	7,520	8,560	8,640	8,750	8,750	9,140	9,720
\$/Section			680	680	680	168	169	171	171	113	120

1/ Three-man crew.

APPENDIX D

GEOGRAPHICAL LABOR DIFFERENCES

APPENDIX D
GEOGRAPHICAL LABOR DIFFERENCES
ADJUSTMENT INDEXES

The costs prepared in this report are based upon January 1, 1985 costs in the Sacramento, California area. Labor adjustment Indexes^{1/} were used and adjusted by setting the values for Sacramento (1.18) equal to 1.0. The indexes for each of the following areas were adjusted accordingly. For example, if the area of interest was Wichita, Kansas, the costs in this report should be multiplied by 0.66.

UNITED STATES

	<u>Labor</u>		<u>Labor</u>
ALABAMA		CONNECTICUT	
Birmingham	.57	Bridgeport	.80
Mobile	.63	Hartford	.80
ALASKA		DELAWARE	
Anchorage	1.26	Dover	.75
Fairbanks	1.26	Wilmington	.75
ARIZONA		DISTRICT OF COLUMBIA	
Phoenix	.75	Washington	.70
Tuscon	.75		
ARKANSAS		FLORIDA	
Fort Smith	.55	Jacksonville	.57
Little Rock	.55	Miami	.65
		Tampa	.69
CALIFORNIA		GEORGIA	
Los Angeles	.99	Atlanta	.62
Sacramento	1.00	Savannah	.57
San Diego	.97		
San Francisco	1.04		
COLORADO		HAWAII	
Colorado Springs	.76	Honolulu	.92
Denver	.77		

^{1/} Guide to Public Works and Heavy Construction Costs, Dodge Construction Cost Information System, Volume 4, 1985.

UNITED STATES

	<u>Labor</u>		<u>Labor</u>
IDAHO		MICHIGAN	
Boise	.76	Detroit	.83
Pocatello	.75	Grand Rapids	.69
		Lansing	.77
ILLINOIS		MINNESOTA	
Chicago	.85	Duluth	.75
Decatur	.79	Minneapolis	.76
Springfield	.77		
INDIANA		MISSISSIPPI	
Evansville	.75	Biloxi	.57
Indianapolis	.76	Jackson	.56
IOWA		MISSOURI	
Davenport	.79	Kansas City	.77
Des Moines	.69	St. Louis	.82
KANSAS		MONTANA	
Topeka	.69	Billings	.73
Wichita	.66	Great Falls	.74
KENTUCKY		NEBRASKA	
Lexington	.73	Lincoln	.69
Louisville	.75	Omaha	.71
LOUISIANA		NEVADA	
New Orleans	.75	Las Vegas	.88
Shreveport	.64	Reno	.90
MAINE		NEW HAMPSHIRE	
Bangor	.71	Concord	.75
Portland	.72	Manchester	.74
MARYLAND		NEW JERSEY	
Annapolis	.65	Camden	.91
Baltimore	.65	Newark	.92
		Trenton	.88
MASSACHUSETTS		NEW MEXICO	
Boston (BASE)	.85	Albuquerque	.63
Springfield	.86	Las Cruces	.64

UNITED STATES

	<u>Labor</u>		<u>Labor</u>
NEW YORK		SOUTH CAROLINA	
Albany	.77	Charleston	.56
Buffalo	.86	Columbia	.54
New York	.97		
Rochester	.78		
Syracuse	.79		
NORTH CAROLINA		SOUTH DAKOTA	
Charlotte	.58	Rapid City	.58
Greensboro	.60	Sioux Falls	.59
NORTH DAKOTA		TENNESSEE	
Bismark	.63	Chattanooga	.58
Fargo	.64	Memphis	.68
		Nashville	.58
OHIO		TEXAS	
Akron	.85	Dallas	.73
Cincinnati	.81	El Paso	.55
Cleveland	.87	Forth Worth	.72
Columbus	.81	Houston	.81
Toledo	.88	San Antonio	.73
Youngstown	.81		
OKLAHOMA		UTAH	
Oklahoma City	.72	Ogden	.86
Tulsa	.73	Salt Lake City	.85
OREGON		VERMONT	
Eugene	.84	Burlington	.69
Portland	.84		
PENNSYLVANIA		VIRGINIA	
Harrisburg	.77	Norfolk	.57
Philadelphia	.83	Richmond	.58
Pittsburgh	.81	Roanoke	.57
RHODE ISLAND		WASHINGTON	
Providence	.76	Seattle	.86
		Spokane	.85

UNITED STATES

	<u>Labor</u>		<u>Labor</u>
WEST VIRGINIA		WYOMING	
Charleston	.75	Casper	.78
Huntington	.76	Cheyenne	.79
WISCONSIN			
Madison	.75		
Milwaukee	.81		

CANADA (No Allowance for Exchange Rate)

ALBERTA		ONTARIO	
Calgary	.87	Ottawa	.81
Edmonton	.87	Toronto	.83
		Windsor	.81
BRITISH COLUMBIA		PRINCE EDWARD ISLAND	
Vancouver	.84	Charlottetown	.60
MANITOBA		QUEBEC	
Winnipeg	.76	Montreal	.69
		Quebec	.69
NEW BRUNSWICK		SASKATCHEWAN	
Fredericton	.61	Regina	.84
St. John	.64		
NOVA SCOTIA			
Halifax	.62		