

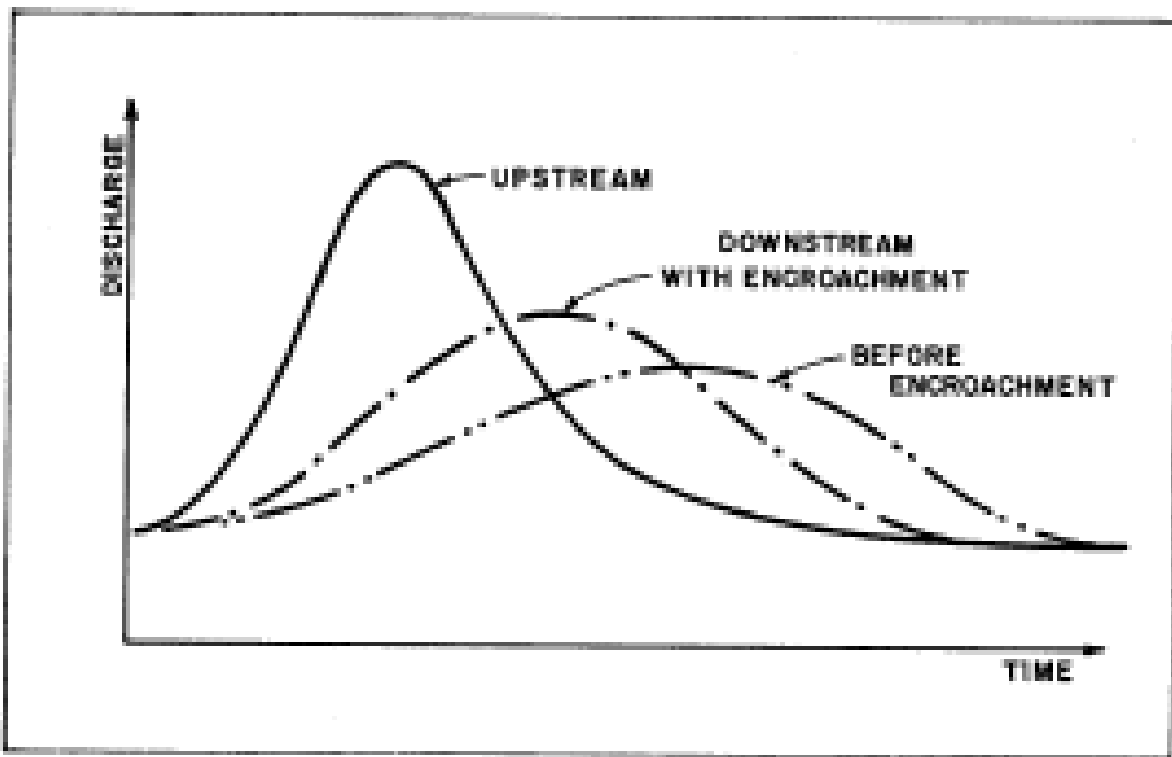

**US Army Corps
of Engineers**
Hydrologic Engineering Center

Effects of Flood Plain Encroachment on Peak Flow



September 1980

REPORT DOCUMENTATION PAGE

Form Approved OMB No. 0704-0188

The public reporting burden for this collection of information is estimated to average 1 hour per response, including the time for reviewing instructions, searching existing data sources, gathering and maintaining the data needed, and completing and reviewing the collection of information. Send comments regarding this burden estimate or any other aspect of this collection of information, including suggestions for reducing this burden, to the Department of Defense, Executive Services and Communications Directorate (0704-0188). Respondents should be aware that notwithstanding any other provision of law, no person shall be subject to any penalty for failing to comply with a collection of information if it does not display a currently valid OMB control number.

PLEASE DO NOT RETURN YOUR FORM TO THE ABOVE ORGANIZATION.

1. REPORT DATE (DD-MM-YYYY) September 1980		2. REPORT TYPE Research Document		3. DATES COVERED (From - To)	
4. TITLE AND SUBTITLE Effects of Flood Plain Encroachments on Peak Flow				5a. CONTRACT NUMBER	
				5b. GRANT NUMBER	
				5c. PROGRAM ELEMENT NUMBER	
				5d. PROJECT NUMBER	
				5e. TASK NUMBER	
6. AUTHOR(S) CEIWR-HEC				5f. WORK UNIT NUMBER	
7. PERFORMING ORGANIZATION NAME(S) AND ADDRESS(ES) US Army Corps of Engineers Institute for Water Resources Hydrologic Engineering Center (HEC) 609 Second Street Davis, CA 95616-4687				8. PERFORMING ORGANIZATION REPORT NUMBER RD-14	
9. SPONSORING/MONITORING AGENCY NAME(S) AND ADDRESS(ES)				10. SPONSOR/ MONITOR'S ACRONYM(S)	
				11. SPONSOR/ MONITOR'S REPORT NUMBER(S)	
12. DISTRIBUTION / AVAILABILITY STATEMENT Approved for public release; distribution is unlimited.					
13. SUPPLEMENTARY NOTES .					
14. ABSTRACT When land development encroachments into river flood plains are permitted, the magnitude of the flood peak discharge will be increased due to removal of flood plain storage. When the flood plain encroachment is limited (for example when nor more than one foot of water surface rise is permitted), the study results indicate that the increase in the flood peak is usually relatively small; it is generally less than ten percent. The arrival time of the flood peak can be affected to a much greater extent, and in stream systems with significant tributary flows, consideration must be given to the effects of encroachments on the coinciding of the flood peaks. Various hydrograph shapes and mean river slopes were used in the investigation of encroachment effects. Both unsteady flow simulations and steady flow profile calculations with hydrologic routing were used in the analyses.					
15. SUBJECT TERMS floods, flood plain encroachments, flood plain modeling, flood routing, river models, water surface profiles					
16. SECURITY CLASSIFICATION OF:			17. LIMITATION OF ABSTRACT UU	18. NUMBER OF PAGES 62	19a. NAME OF RESPONSIBLE PERSON
a. REPORT U	b. ABSTRACT U	c. THIS PAGE U			19b. TELEPHONE NUMBER

Effects of Flood Plain Encroachment on Peak Flow

September 1980

US Army Corps of Engineers
Institute for Water Resources
Hydrologic Engineering Center
609 Second Street
Davis, CA 95616

(530) 756-1104
(530) 756-8250 FAX
www.hec.usace.army.mil

RD-14

EFFECTS OF FLOOD PLAIN ENCROACHMENTS ON PEAK FLOW

Table of Contents

<u>Subject</u>	<u>Page</u>
Abstract	<i>iii</i>
Acknowledgements	<i>iv</i>
Summary	<i>v</i>
1. INTRODUCTION	1
1.1 Purpose of Study	1
1.2 Study Background	2
1.3 Literature Review	3
2. APPROACHES USED IN STUDY	8
2.1 Flood Wave Movement in Rivers	8
2.2 Formulation of the Problem	12
2.3 Unsteady Flow Analyses	14
2.4 Search for Field Data	19
3. STUDY RESULTS	20
3.1 General	20
3.2 Background on Case Studies	20
3.3 Unsteady Flow Analyses	24
4. GENERAL APPLICATION OF RESULTS	38
4.1 Procedures and Guidelines	38
4.2 Other Considerations	39
4.3 Examples	40
5. REFERENCES	43
Appendix	A-1

LIST OF TABLES AND FIGURES

<u>Table</u>	<u>Page</u>
3.1 Effects of Encroachments Using Hydrologic Routing Methods	23
3.2 Results of Unsteady Flow Analysis	26
<u>Figure</u>	<u>Page</u>
2.1 Flood Hydrograph Attenuation	9
2.2 Schematic Diagram of River with Floodplain	10
2.3 Typical Stage-Discharge Relationship for Rivers	11
2.4 River and Flood Plain Section Used in this Study	17
2.5 Hydrographs Used in this Study	18
3.1 Typical Watershed and Channel Routing Reach	21
3.2 River Cross Section Used in Analysis	21
3.3 Approximation to Hydrograph Using a Triangular Shape	25
3.4 Relative Flood Peak as a Function of Valley Width for $S = 0.0001$	28
3.5 Relative Flood Peak as a Function of Valley Width for $S = 0.001$	29
3.6 Effect of Timing of Peak on Routed Hydrograph Shape	30
3.7 Increase in Flood Peak Flow as a Function of the Reduction in Flood Plain Area	31
3.8 Effect of Slope on Routed Hydrographs	33
3.9 Flood Peak Flow as a Function of Valley Width for Two River Slopes	34
3.10 Maximum Water Depth on Flood Plain as a Function of Valley Width for Two River Slopes	34
3.11 Effect of Channel Slope on Stage Hydrograph	35
3.12 Effect of Valley Width on Timing of Hydrograph Peak	37

EFFECTS OF FLOOD PLAIN ENCROACHMENTS ON PEAK FLOW

ABSTRACT

When land development encroachments into river flood plains are permitted, the magnitude of the flood peak discharge will be increased due to removal of flood plain storage. When the flood plain encroachment is limited (for example, when no more than one foot of water surface rise is permitted), the study results indicate that the increase in the flood peak is usually relatively small; it is generally less than 10 percent. The arrival time of the flood peak can be affected to a much greater extent, and in stream systems with significant tributary flows, consideration must be given to the effects of encroachments on the coinciding of the flood peaks. Various hydrograph shapes and mean river slopes were used in the investigation of encroachment effects. Both unsteady flow simulations and steady flow profile calculations with hydrologic routing were used in the analyses.

ACKNOWLEDGMENTS

The very helpful suggestions and comments provided by Arlen Feldman, John Peters and Bill Johnson of the Hydrologic Engineering Center are greatly appreciated. Typing of the report was done by Eileen Tomita. The report drawings were prepared by Roger Nutter, and Wayne Pearson did most of the computer work. Director of the Hydrologic Engineering Center during the study period was Bill S. Eichert.

Funding for the study was provided by the Office of the Chief of Engineers, U.S. Army Corps of Engineers, Washington, D. C.

SUMMARY

Development of river flood plains results in removal of areas in which water is temporarily stored during the passage of floods. This flood plain storage is an important factor in the attenuation of flood peak flows, and also in the reduction of flood levels. As a consequence, land development encroachments into flood plains are usually controlled to permit only limited water level increases.

It was determined in this study that when the flood plain encroachment is limited (for example, when the maximum water surface rise is limited to one foot), the increase in the magnitude of the flood peak is usually small, in most cases it is less than 10 percent. The arrival time of the flood peak can be affected to a much greater extent, however. Therefore, in stream systems with significant tributary flows, consideration must be given to the effects of encroachments on the combining of the flows, since a substantial increase in peak flow may result at certain locations. The analyses made in this study provide some general indications of the effects of encroachments on flood characteristics; however, the problem is such that each individual case must be analyzed separately if numerical results are required. Procedures for this are available and should be used when it is expected that an increase in flood peak flow would cause problems. A major purpose of this report is to provide guidance to help identify those hydraulic situations where significant increases in flood discharge peak can be anticipated.

Encroachment effects were determined for a simple river channel and flood plain reach with constant slope, roughness, and width. Several flood plain widths were used as well as two different river slopes. Some results

are given for steady flow profile analyses with attenuation effects determined using hydrologic routing techniques.

Unsteady flow simulation with the "Gradually Varied Unsteady Flow" computer program was used for the major portion of the work. Five different hydrograph shapes were used. It was found in this study that the effect of a given encroachment is less in steeper rivers than in flatter ones. Also, the effects of hydrograph shape are relatively independent of valley width for steeper slopes. The hydrograph shape is an important factor in flood wave attenuation for flatter river slopes, however.

In general, the situations which produced the greatest increases in peak flow were those with the flattest slopes, with the largest reduction in storage, and with the hydrograph peak early in the flood event. If a combination of these factors exists, increases in peak flow can be substantial.

1. INTRODUCTION

1.1 Purpose of Study

The purpose of this study is to provide guidelines for the assessment of the effects of flood plain encroachments on flood peak flow, maximum water surface elevations, and flood-peak arrival times. Because each river presents a unique hydraulic problem due to its unique geometry, types of lateral inflow conditions, and other conditions, each situation must be analyzed separately. However, as illustrated in this report, some general guidelines can be developed which will indicate when potential problems can arise. If problems are indicated, then further study can be made to provide more definitive answers.

Much attention has been devoted in recent years to establishing limits to encroachments into flood plains to reduce damages due to flooding. The National Flood Insurance Program (Federal Insurance Administration, 1977) has provided the impetus for many studies of this nature. In these investigations, the maximum floodway encroachments are defined on the basis of some maximum rise in the flood water level (usually one foot or less). However, the effect of the encroachments on the magnitude of flood peak flow has frequently been ignored in these studies, primarily because the steady-flow analysis commonly used does not provide a means of determining the effect of encroachments on the discharge.

The rate of movement of the flood wave down the river can also be affected significantly by encroachments, as a result of the elimination of areas for water storage on the flood plain. However, the commonly used steady-state hydraulic analyses provide little information regarding wave travel times, other than what can be inferred from mean flow velocities, and an unsteady flow model may be required if flood wave movement is of interest.

Why should one be concerned about flood peak flow values or changes in the timing of the flood peak? The answer to this question is: if flood peak flows are significantly increased by flood plain encroachments, downstream areas may have reduced protection from floods. The flood-peak arrival time may also be of concern, because encroachments usually increase the flood-wave speed. This causes peak flows to occur earlier, thus giving less time to respond to flood warnings. On streams with tributaries, a change in the timing of the peak may be beneficial or detrimental, depending on whether or not the peak flows of the tributary and main-stem coincide.

This report discusses some of the types of flood events for which significant increases in flood peaks may occur as a result of encroachments into the flood plain. It provides guidance for the engineer making flood plain investigations by indicating the type of situations for which additional effort should be devoted to computing the flow through the affected reach of river by flood routing techniques. This study is concerned primarily with situations in which the flood plain encroachments follow the criteria for flood insurance studies, i.e., encroachments that cause a one foot (or less) rise in the water surface. Encroachments causing large water surface changes will affect the flood hydrograph to a much greater degree and different procedures may have to be used for these cases.

1.2 Study Background

This study was initiated in response to a request from the Flood Plain Management Services Branch, Office of the Chief of Engineers, U. S. Army Corps of Engineers. An early phase of this investigation involved the evaluation of some typical encroachment problems. Analyses were made using computer programs HEC-1 and HEC-2. Flood hydrographs were determined by basin modeling with HEC-1

(Hydrologic Engineering Center, 1973). The flood peak flows from the HEC-1 results were used to determine encroachment limits such that the rise in the water surface with the encroachments was no more than one foot. Standard techniques for determining encroachment limits were followed using the encroachment options of computer program HEC-2 (Hydrologic Engineering Center, 1979). Several representative watersheds and flood channels were investigated in this work. A summary of the results of this initial work is included in Chapter 3.

In a later phase of the study, the major effort was concentrated on the use of unsteady-flow-analysis techniques to develop relationships between parameters describing the flood plain and encroachments and the flood hydrograph. A number of the earlier HEC-2 runs were duplicated using an unsteady open-channel-flow computer program. Simplified flood routing techniques were also used, and these simplified procedures also proved useful in the development of guidelines. The results of these analyses are described in Chapter 3.

1.3 Literature Review

A number of reports and papers dealing with the effects of flood plains on flood hydrographs were reviewed. The problem is of world-wide concern; however, no simple and widely applicable answer to the problem was found in the literature. The approach generally conceded to be the best way of evaluating attenuation problems is to perform an unsteady flow analysis of the particular river, using a computer program which solves the full unsteady flow equations, if needed. In most practical applications however, hydrologic or hydraulic flood routing techniques are used to route flood flows, and water surface elevations are then determined by steady open-channel flow computations using the appropriate flow values. Physical models are also used to determine encroachment effects. Although costly, they permit details of the flow patterns to be studied.

Most of the literature reviewed dealt with the general effects of flood plains on flood hydrographs, and did not specifically treat flood plain encroachments. A comprehensive presentation of the general subject of flood routing in rivers is that of the Natural Environment Research Council of Great Britain (1975), which covers flood routing methods, theory, and applications. Although the material is slanted toward use with British rivers, it is general enough to be applicable to a wide range of river types.

Abbott, et al. (1971) compared the results obtained using a numerical model of a river and flood plain system with data from the Danube River and from a physical model of the Danube. They concluded that a one-dimensional numerical model can give good simulation of flood events if storage capacity as a function of stage and the effective flood plain roughness are accurately specified.

Some observations of flood plain influences on flood waves for Russian rivers are reported by Grashevsky (1967). He also made numerical analyses of simple channels with flood plains. His studies indicated that flood plain "accessibility," i.e., the relative ability of the water to leave the river and enter the flood plain, was an important factor in flood wave attenuation. If a flood wave moves past areas in which large amounts of potential flood plain storage exist, but the movement of water into these areas is restricted by high hydraulic roughness in overbank areas or by limited openings to the flood plains, then the full available storage may not be utilized. Grashevsky also observed that in channels with slopes on the order of 0.001 the attenuation of the flood wave was observed to be much less than with channels with flatter slopes.

Huang and Gaynor (1977) studied the downstream effects of stream channel improvements on floods using a computer program which utilized kinematic routing. Their general conclusion was that "channel improvements" cause downstream flood hydrographs to have higher peaks and also cause the peak flow to occur earlier.

Johnson and Senter (1977) evaluated the loss of flood plain storage on the Ohio River for long river reaches. They simulated different amounts of storage loss ranging from complete removal of valley storage by use of levees to partial loss of valley storage with levees on only the downstream portion of the river (the lower 58 miles). Also examined were the effects of increasing or decreasing the Manning's 'n' values by 20 percent. They concluded that for the reach of the Ohio River they were studying, the flood height would not be substantially changed by complete loss of valley storage or by substantial variation in Manning's 'n'.

Effects of proposed encroachments in the flood plain of the Connecticut River were studied by Dewey and Kropper (1964). They examined the consequences of removing major volumes of valley storage along 40 miles of the Connecticut River. Storage routing techniques were used in these analyses. The general effects noted included:

- (1) A 10 to 40 percent increase in peak discharge downstream as a result of the loss of 10 to 30 percent of the valley storage;
and
- (2) An increase in water surface elevations for major flood discharges as a consequence of the decrease in waterway cross-sectional areas.

The approximate increases in water surface elevation were: (a) 1 foot for a 10 percent reduction in valley storage, (b) 4 foot increase for 20 percent reduction, and (c) 7 feet for a 30 percent reduction.

A large number of hydraulic model studies involving the effects of levees and other types of encroachments on river water levels have been made by the U. S. Army Corps of Engineers, Waterways Experiment Station (WES). In these studies, major changes to river flow areas and flow patterns were examined. These frequently result in water level changes of several feet for major flood events. Examples of these types of studies are given in the reports describing the various WES investigations using the Mississippi River Basin Model (e.g., Waterways Experiment Station, 1955a; 1955b; 1959; 1971).

The effects of levees and encroachments on design flood profiles were determined in this very large physical model using hypothetical flood waves (for "normal floods" and flash floods). In addition to these unsteady flow analyses, steady-flow tests were also made. Stage-discharge hydrographs were measured for the unsteady flows, and water surface profiles for the steady flows were determined for two cases: before and after levees were positioned in the model.

A comparison of various approaches is given by a study by Huntington (1974) which involved both a physical and a mathematical model. He found that the mathematical model gave results that matched the physical model quite well in general, although in the flood plain itself the mathematical model consistently overestimated the flood levels. This was considered to be due primarily to the ignoring of the fine-scale details of the river and flood plain geometry in the mathematical model as well as neglecting the head loss factors at the entrance to and exit from the flood plain. However, these were minor errors, and Huntington concluded that mathematical models of unsteady river flow can provide good simulation of both flood flow magnitudes and stages in the analysis of rivers with flood plains.

An additional factor that should be considered is that the actual water surface rise will often be less than the computed because the full proposed encroachments frequently do not occur. In a recent survey by Goddard (1979), it was found that the actual development on flood plains resulted in an average "flow" blockage of only 25 percent (although the blockage varied from zero to 100 percent). In most cases, therefore, significant flood plain storage is still available even though the floodway fringe is developed.

Goddard's survey also showed that actual floodway encroachments usually result in a water surface increase that is significantly lower than 1.0 ft. For the floodways which he evaluated the mean water surface increase was about 0.7 feet.

2. APPROACHES USED IN STUDY

2.1 Flood Wave Movement in Rivers

As a flood wave moves downstream in a river, it is perceived at a given point in the river as first a rise and then, after the peak has passed, as a lowering of the water surface. In all channels, as the magnitude of flow increases, the stage also increases, and water in temporary storage in the river will increase as well. Because some of the water entering a given reach of the river goes into storage, the rate of flow leaving the reach is decreased as the consequence of maintaining a balance between the volumes of water entering and leaving the reach and the volume stored in the reach at any given time. This decrease in flow is called the "attenuation" of the flood wave and occurs to some degree in all channels; Figure 2.1 shows a typical situation. In rivers with wide flood plains the volume of overbank storage can be quite large as is indicated in Figure 2.2. This storage can be an important factor in reducing flood flows downstream.

As the flow decreases and the river stage falls, the water stored in the channel and in the overbank areas is released from storage. This lengthens the time base of the flood. Because the energy gradient is steeper on the rising side of a flood wave than on the falling side, the flow is greater on the rising side for a given stage. This is illustrated by the looped stage-discharge relationship in Figure 2.3.

An important effect of storage on the flood hydrograph, therefore, is attenuation of the peak discharge. Removal of flood plain areas by fills, levees, buildings, road embankments, or other encroachments will reduce the volume of temporary flood storage, and thus there will be less attenuation

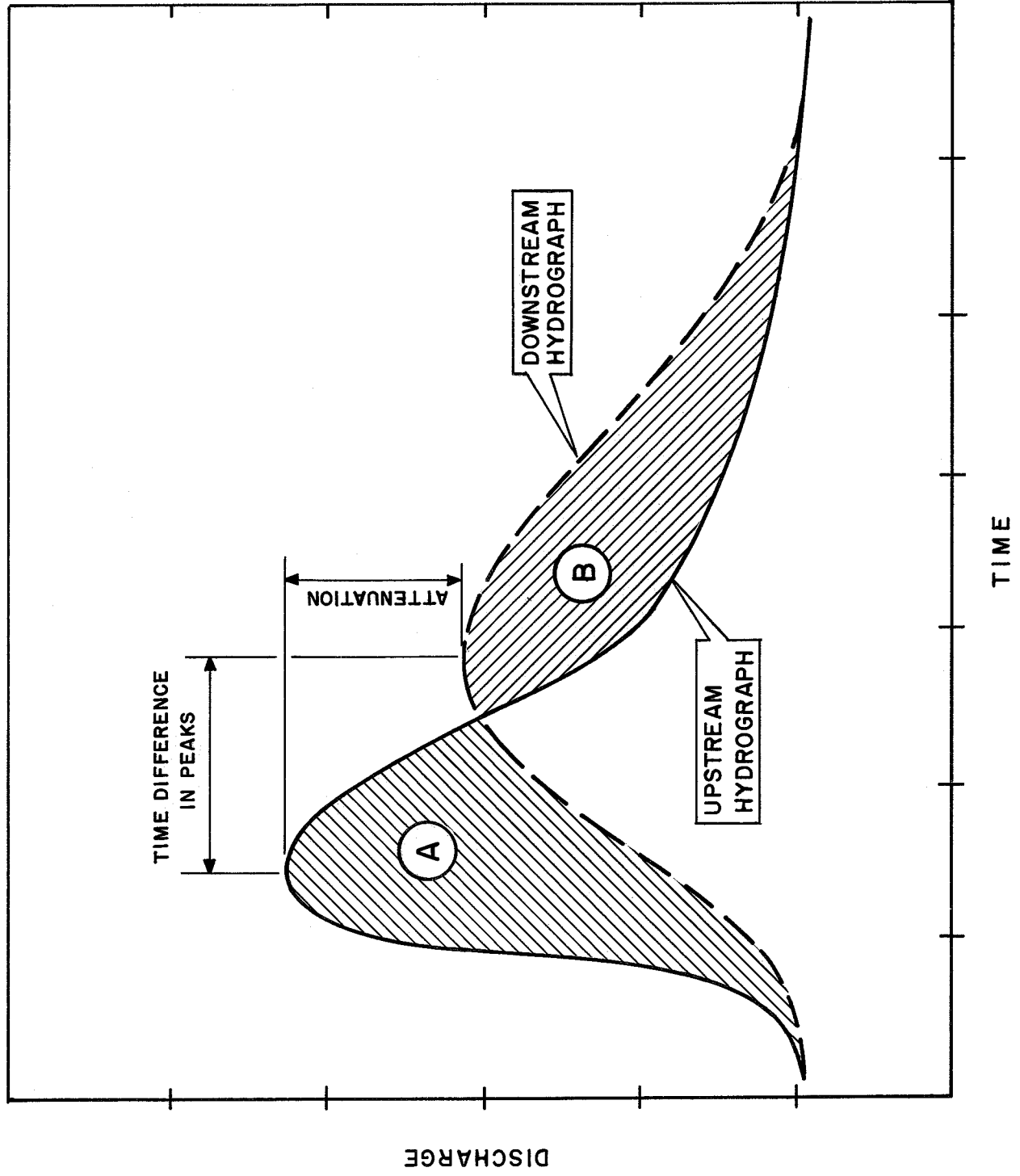
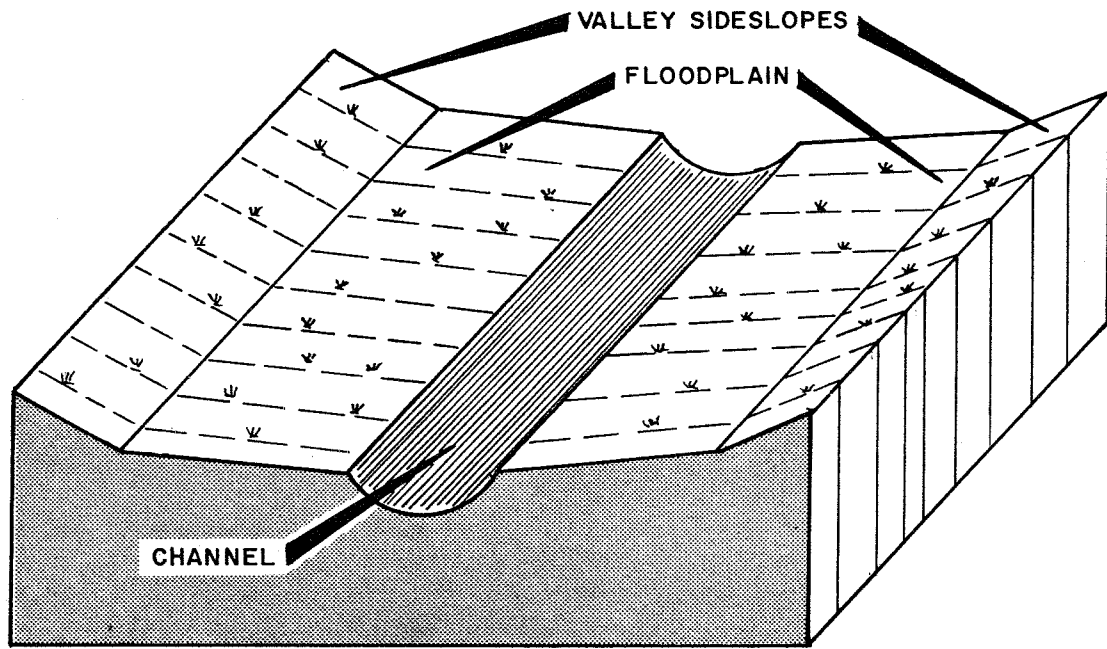
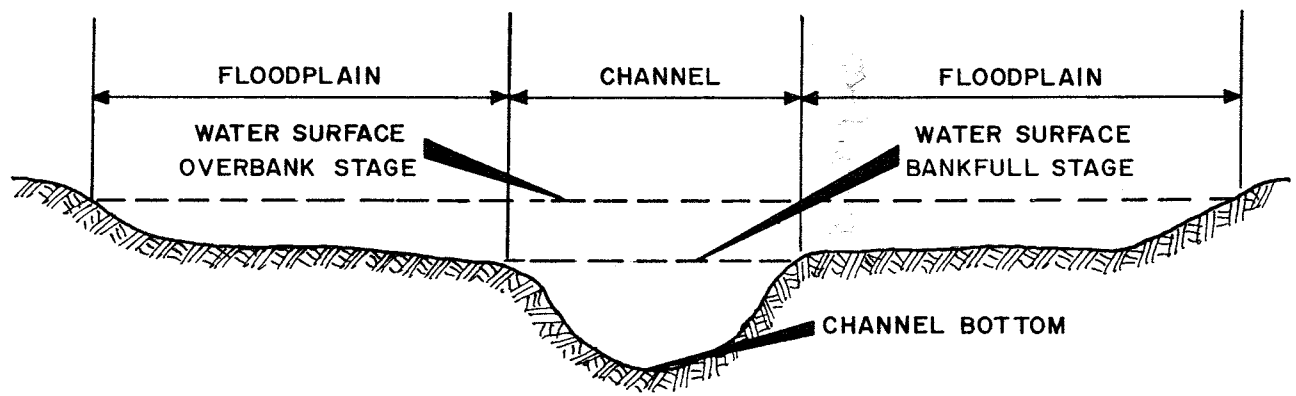

FIGURE 2.1 Flood Hydrograph Attenuation



TYPICAL VALLEY SEGMENT



TYPICAL VALLEY SECTION

FIGURE 2.2. Schematic Diagram of River with Floodplain

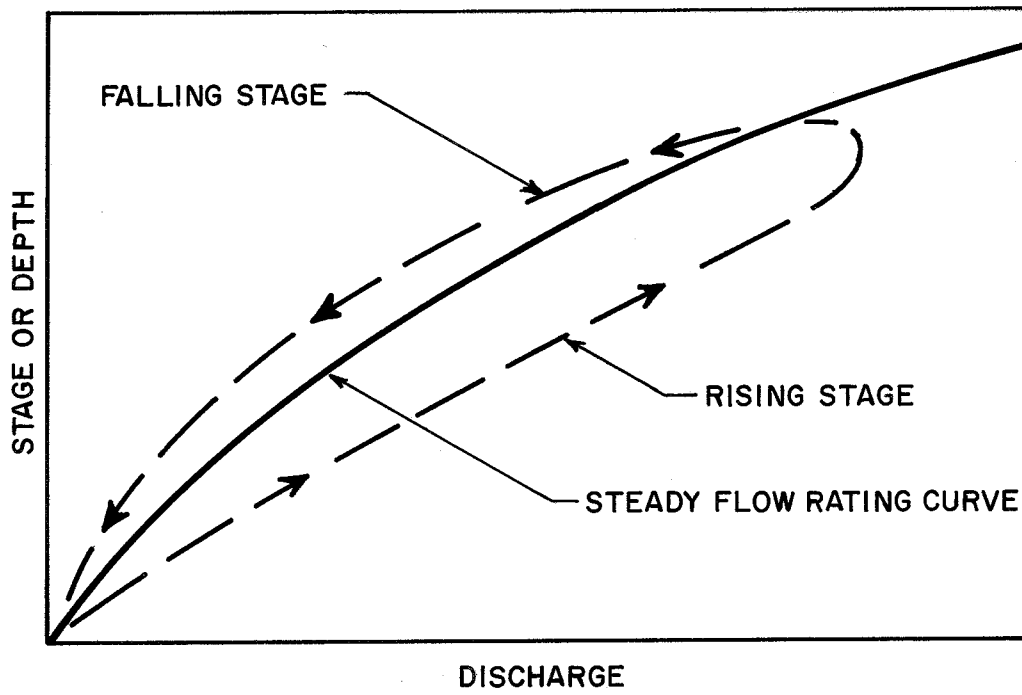

FIGURE 2.3 Typical Stage-Discharge Relationship for Rivers

of the flood peak. The resulting higher flows may significantly change flood flow-frequency relationships downstream from the encroached reach from those previously existing. The higher discharges may cause significant increases in water surface elevations. And, as mentioned above, problems related to changes in timing of the flood peaks may arise if combinations with tributary flows are significant.

An encroachment can cause backwater effects (and hence an increase in channel and overbank storage) upstream from the encroachment. This can be as significant as the loss in storage due to the encroachment in some cases.

2.2 Formulation of the Problem

In studies made to establish encroachment limits (such as flood insurance studies), the peak flow for a given level flood, say the 1% (100-year) flood, is used with a steady-flow analysis to determine the floodway limits for which the water surface does not rise more than a specified amount (usually one foot) above the natural-condition profile (Goddard, 1979). In the steady flow analysis, the width of the waterway (and thus also its ability to carry the flood flow) is reduced by the amount which gives the specified water level rise. However, in most cases the effect of the loss of flood plain storage on the magnitude of the discharge is ignored in the steady flow analysis.

For flood events resulting from intense, relatively short-duration storms, the flood hydrograph generally has a sharp peak. For this type of event, the effects of flood plain storage can be very significant. In contrast, when the rainfall duration is long relative to basin response time or when the flood results from snowmelt such that high flows persist for a long time, the rate of change in flow is relatively small, and steady-state assumptions usually give good results.

The engineer or hydrologist who is involved in determining flood plain encroachment limits usually has the following information with which to work: (1) either a flood hydrograph for the reach of river under study, or more likely, the magnitude of the flood peak, (2) a detailed description of the river and flood-plain geometry (such as cross sections), and (3) some measure of the hydraulic roughness characteristics of the river (such as Manning's 'n' values). The objective of the study is to define the allowable encroachment limits and determine water surface profiles with and without encroachments.

When performing an encroachment study, the hydrologist should consider the following questions:

- (1) Will there be significant changes to the flood hydrograph due to the encroachment? Most importantly, will the peak flow at a given downstream location increase as a result of the encroachment?
- (2) How is the arrival time of the flood peak affected by the encroachment?

Answers to these questions are attempted in two ways in this report: In the first, analytical approaches based on unsteady flow computations are used; in the second, information from observed flood events and results of hydraulic model studies are evaluated to determine the usefulness of various analytical approaches.

It is assumed here that the flood hydrograph is known at some point upstream from the proposed encroachment. The problem therefore, is one of routing this flood hydrograph to some downstream point to determine not only the maximum flow at that point, but also the maximum water surface elevation associated with the flow. The problem is basically an unsteady open-channel-hydraulics problem.

There are a number of methods available for making flood routing computations (Henderson, 1966; Strelkoff, 1969). The basic equations for the description of unsteady open channel flow (the St. Venant equations) have been known since the latter part of the nineteenth century, but it is only since the advent of large digital computers that numerical solutions to the full equations of motion can be made. Solutions of the full St. Venant equations are not routinely used, because they are much more difficult and costly than other methods. Also, the available procedures require knowledge of both hydraulic theory and numerical analysis techniques, as well as access to a computer. As a consequence, most flood routing is done using simplified routing methods (Weinmann and Laurenson, 1979). In many cases, in fact, simplified methods give results that are nearly as accurate as those obtained from the full St. Venant equations. For example, for rivers with slopes greater than 0.001 some of the terms in the full equations can be neglected (Henderson, 1966; Natural Environment Research Council, 1975), and it is not necessary to use the full equations.

2.3 Unsteady Flow Analyses

Full Equations of Motion. The computer program which was used in this study to analyze the effects of encroachments on floods is titled "Gradually Varied Unsteady Flow Profiles, Flood Routing by the Hydraulic Method." The program is available from and maintained by the Hydrologic Engineering Center (Hydrologic Engineering Center, 1977). It is based on the "TVA Model" described by Garrison, et al. (1969).

The full equations describing open channel flow are used in this computer program, and thus this analysis simulates the effect on the flow resulting from changes in flow cross-sectional area as the flood wave moves along the river.

However, the program, because it is a "one-dimensional" model, takes into account only the motion of the water in the direction of the channel axis. It does not make provision for water movement from the channel out into the flood plain and back into the channel again, except in the accounting of total water volume. Even with these limitations however, this type of model has been shown to give good simulation of actual flood events in many cases. This approach was selected for analyses described subsequently.

Detailed treatments of the hydraulics of rivers and flood plain interactions are described in the literature. Liggett (1968), for example, treated the flood plain as an offstream storage element that contributed only partially to through-flow. This type of formulation is useful when evaluating the storage effects of water backed-up in a tributary, for example. This can be handled in the Gradually Varied Unsteady Flow program by the use of "non-conveyance" areas in a cross section.

Fread (1976) treated the flow in the main channel separately from the flood plain flow (both are considered one-dimensional flows). The effects of a meandering river in a wide flood plain can be taken into account in this approach since the quantity of flow as well as the flow path lengths and hydraulic properties are accounted for separately.

The process of energy transfer between the main channel and the flood plain was considered in a flood routing approach by Radojkovic (1976). The effects of channel shape on resistance in flood plain channels was studied by Yen and Overton (1973), Wright and Carstens (1970), and Malhotra (1968). In these studies, the flow was treated as one-dimensional, a reasonable assumption for both the main channel and flood plain flows if extensive meandering does not occur, as indicated by the experimental study of Toebe and Sooke (1967).

A simple and uniform river-channel and flood-plain geometry was used in this study to provide cross sections which were easy to describe. The main concern here is to be able to define the loss of flood plain storage due to encroachments in relation to other parameters. The river cross-sectional shape used is shown in Figure 2.4. It is symmetrical about the channel center line. Constant channel slopes of 0.0001 and 0.001 (0.5 ft/mi and 5 ft/mi) were used. A single Manning's 'n' was used to characterize the roughness of the full cross section.

A 5.4-mile long channel reach was used as the study reach. A flood hydrograph was introduced at its upstream end, and the flow was routed downstream. The downstream boundary condition was taken as normal depth plus 0.1 feet at a point 0.7 miles downstream from the end of the study reach (i.e., 6.1 miles from the upstream end). This was found to give a reasonable representation of downstream conditions. Runs made using the same boundary condition one mile further downstream gave similar results.

The flood hydrograph at the upstream end of the reach was represented as triangular in form for simplicity. More critical than the precise shape of the hydrograph is the timing of the peak flow relative to the beginning of the hydrograph. To evaluate this, several different hydrograph shapes, each with different times to flood peak were used. The various hydrographs are shown in Figure 2.5.

Simplified Flood Routing Methods. As mentioned above, in many cases, it is not necessary to use the full equations of motion for analyzing unsteady river flows. In fact, most flood routing in practice is done either by "hydrologic" (storage-routing) methods or by simplified "hydraulic" routing methods (such as the kinematic wave or diffusion equations) which are based on simplified forms of the equations of motion.

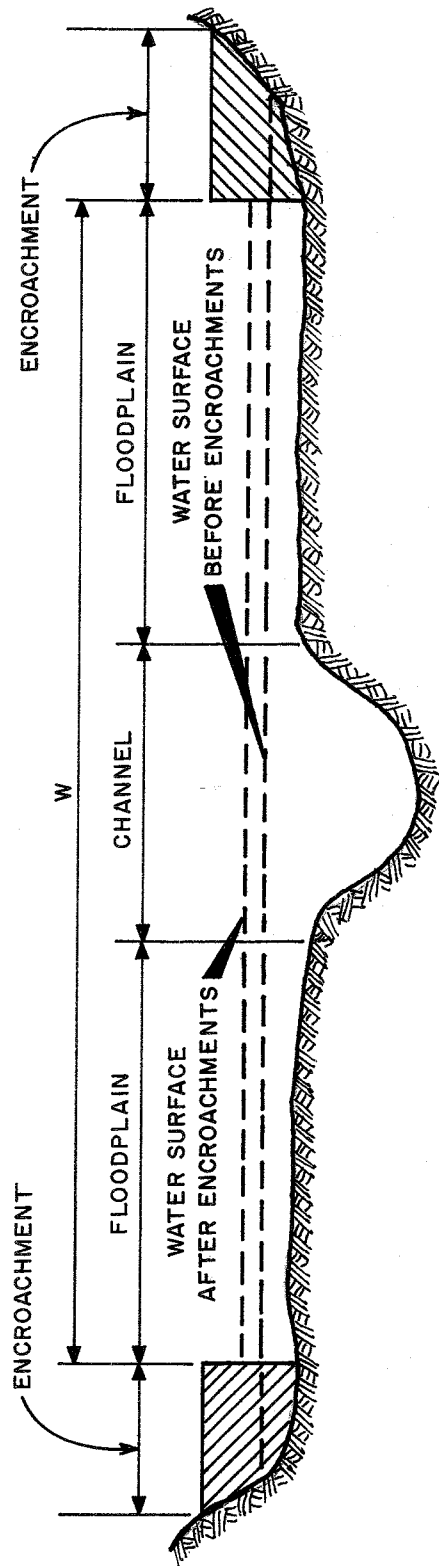

TYPICAL VALLEY SECTION WITH ENCROACHMENTS

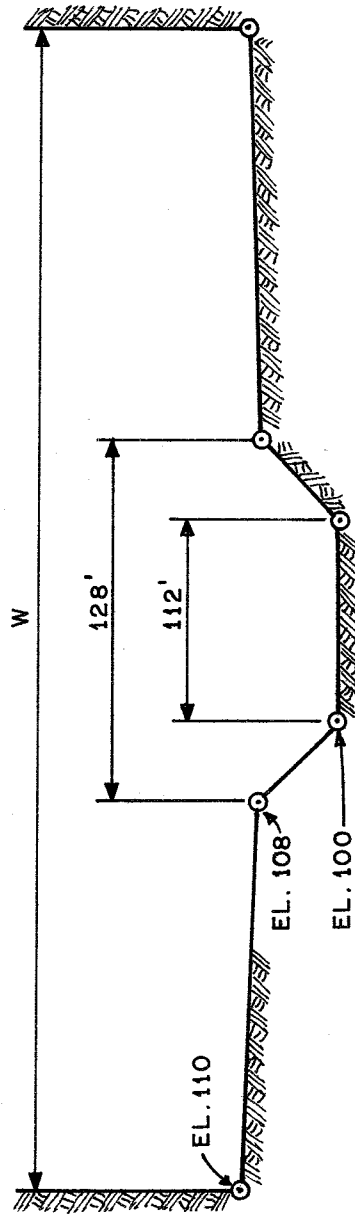

RIVER CROSS SECTION USED IN ANALYSIS

FIGURE 2.4 River and Flood Plain Sections Used in this Study

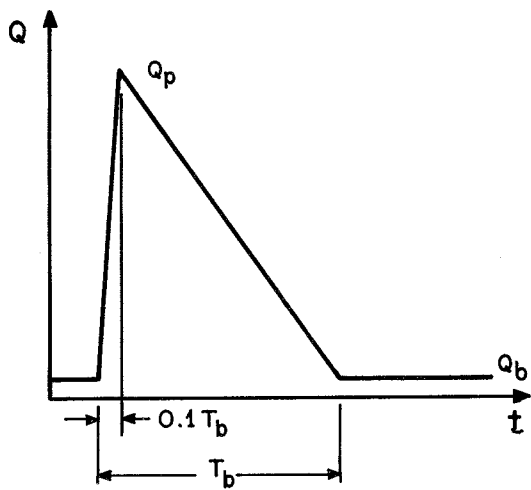

HYDROGRAPH 1

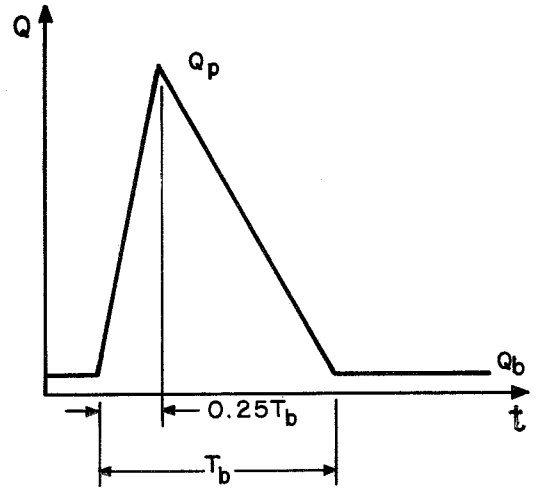

HYDROGRAPH 2

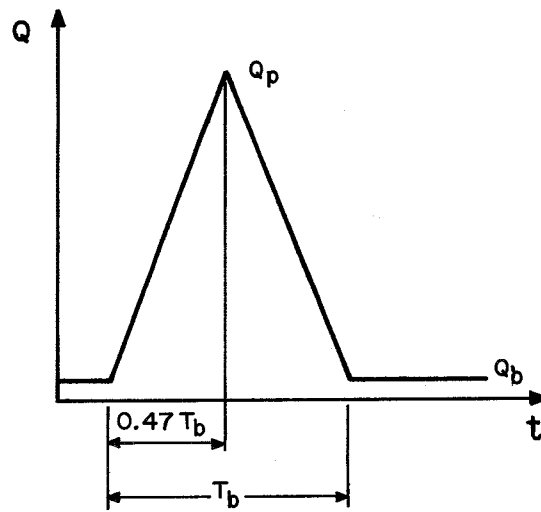

HYDROGRAPH 3

$Q_p = 34,000$ cfs
 $Q_b = 1,000$ cfs
 $T_b = 2$ hr-30min

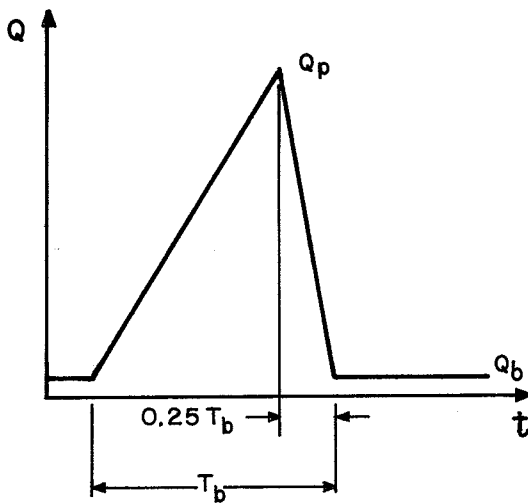

HYDROGRAPH 4

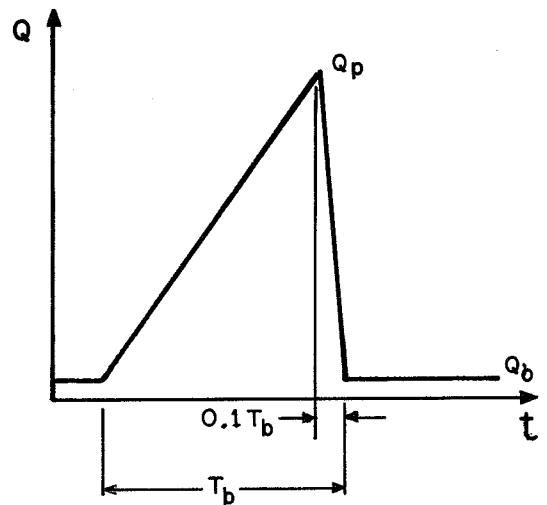

HYDROGRAPH 5

FIGURE 2.5 Hydrographs Used in this Study

Perhaps the most widely-used of the hydrologic methods are the Muskingum and modified-Puls methods. In the hydraulic routing group are the kinematic wave method and solutions to the "convection-diffusion" equation (Natural Environment Research Council, 1975). The convection-diffusion equation was also used in this study to illustrate how various factors, such as hydrograph shape, affect flood wave attenuation. Additional discussion of the convection-diffusion equation approach is given in the Appendix.

2.4 Search for Field Data

A search for field data pertinent to the problems considered in this study was of very limited success. Flood plain management units in various Corps of Engineers Districts around the country were contacted. They were asked for information on rivers for which data might be available on floods which occurred both before and after encroachments (such as levees) were placed in the flood plain. As a result of this search several rivers were suggested for evaluation. However, no numerical evaluation of encroachment effects could be made, because sufficient data to properly describe the problem were not available in all cases examined.

A major obstacle to acquiring field data that describe encroachment effects is that most flood plain encroachments are in areas that also experience rapid development (such as urbanization) in major portions of the watershed. As a consequence, the hydrologic characteristics of the watershed may change greatly, and it is not possible to separate the encroachment effects from influences of other watershed changes on a flood hydrograph.

3. STUDY RESULTS

3.1 General

The natural attenuation (reduction in amplitude) of a flood wave is dependent on a number of factors. These include:

- (1) The area available in the overbank regions to provide off-stream storage.
- (2) The slope of the river.
- (3) The shape of the hydrograph, especially the curvature at the peak.
- (4) The travel time (or speed) of the flood wave.

This study is concerned primarily with the effects of encroachment which produce a limited change in the flood elevation (encroachments which follow the guidelines established by the Flood Insurance Program). Therefore, the main emphasis here is on the evaluation of the effects of encroachments producing a one-foot rise in water surface elevation. Encroachments of greater magnitude which will cause more pronounced changes are not considered here.

3.2 Background on Case Studies

A hypothetical watershed and downstream channel reach (shown schematically in Figure 3.1) were used in the first phases of the study. This watershed and channel were chosen to be representative of conditions that might occur in a moderate-size basin (400 sq mi). An inflow hydrograph for the upper end of the routing channel was based on a design storm calculated using the unit hydrograph computational procedures available in computer program HEC-1 (Hydrologic Engineering Center, 1973). Various basin slopes and channel lengths

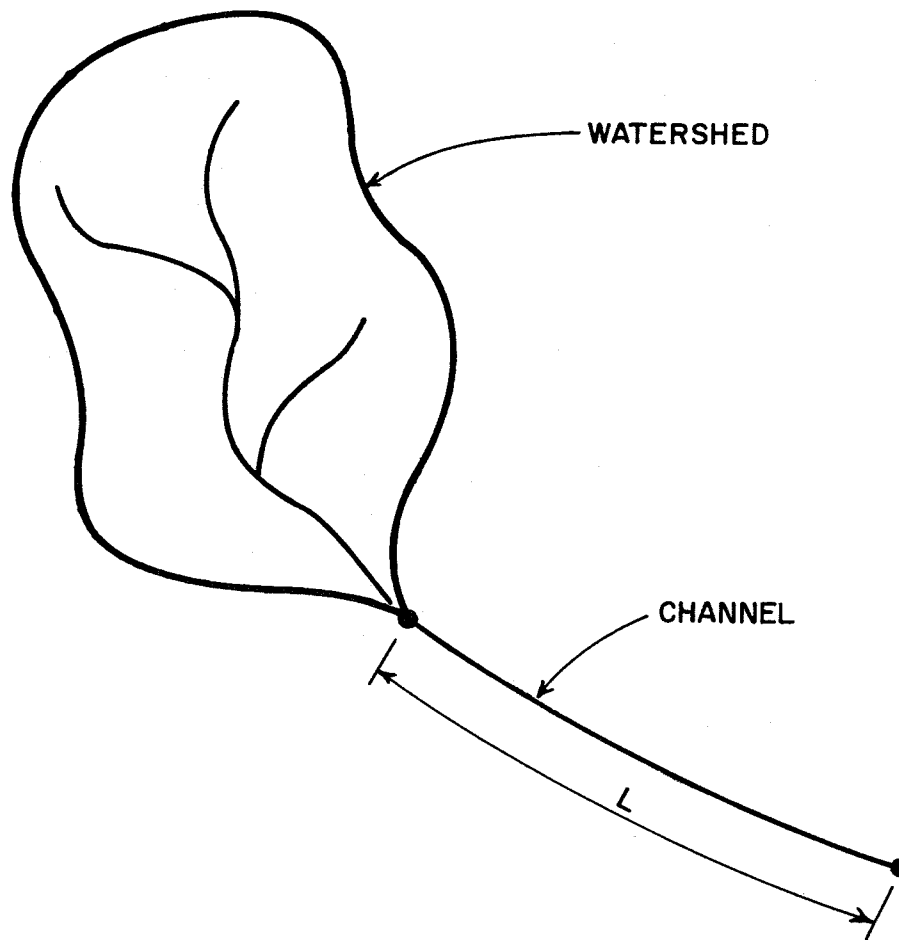

FIGURE 3.1 Typical Watershed and Channel Routing Reach

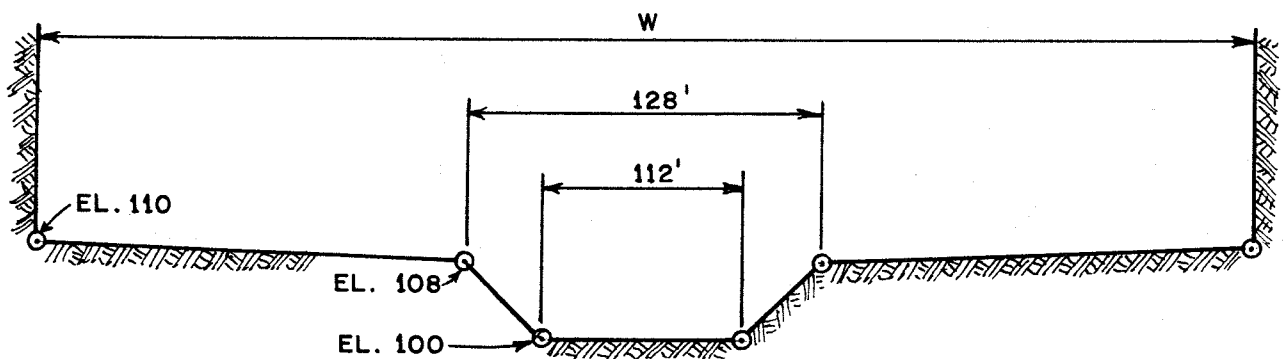

FIGURE 3.2 River Cross Section Used in Analysis

were used in the computer runs to evaluate their effect on basin response (i.e., on hydrograph characteristics).

Two different channel slopes and several flood plain widths were used with the flood plain and channel cross section shown in Figure 3.2. Both the channel slope and cross section were assumed to be constant along the length of the channel. A steady flow simulation for each individual channel width was made using computer program HEC-2 (Hydrologic Engineering Center, 1979). The HEC-2 runs were made with the option which permits automatic determination of encroachment limits to match a target value of water surface elevation rise. The encroachment which caused a water surface elevation exactly one foot higher than under original conditions was determined for each case. The peak flow for the computed hydrograph at the upstream end of the reach was used as the discharge through the complete reach for the determination of encroachment limits, a commonly used procedure for these types of studies. The results of these calculations are presented in Table 3.1. The reduction in river top width for the cases analyzed ranged from 11 to 38 percent, with corresponding losses in valley storage of 5 to 17 percent.

The original hydrographs were routed through five-mile and ten-mile channel reaches using storage-routing procedures (modified-Puls method) of program HEC-1. The largest increases in peak flow were about 16 percent for the ten-mile reach and about 9 percent for the five-mile reach. Most of the cases examined had much smaller peak flow increases. The situations which produced the greatest increases were those with the flattest slopes, the largest reduction in storage, and an early-peaked hydrograph. If a combination of these factors exists, the increases can become quite significant.

TABLE 3.1

EFFECTS OF ENCROACHMENTS USING HYDROLOGIC ROUTING METHODS

	CASE								
	1	2	3	4	5	6	7	8	9
<u>Watershed Parameters</u>									
Drainage Area (sq mi)	400	400	400	400	400	400	400	400	400
Basin Slope (ft/mi)	29	29	29	29	29	29	53	53	53
<u>Stream Parameters</u>									
Slope	.001	.001	.001	.0001	.0001	.0001	.0001	.0001	.0001
Q within Banks (%)	20	40	60	20	40	60	20	40	60
Valley Width (ft)	5000	800	350	8600	1600	730	10270	1750	770
Depth on Overbank (ft)	3.2	8.8	13.6	4.4	11.1	16.6	4.5	12.0	18.0
<u>Floodway Parameters</u>									
Change in Elevation (ft)	+1.0	+1.0	+1.0	+1.0	+1.0	+1.0	+1.0	+1.0	+1.0
Reduction in Top Width (ft)	1899	148	58	2610	244	85	3062	249	83
Reduction in Top Width (%)	38	18	17	30	15	12	30	14	11
Valley Storage Lost (%)	17	8	6	14	7	6	13	6	5
<u>Change in Peak Flow</u>									
Five Mile Reach									
Increase in Peak Q (%)	2.4	0.2	0.2	8.1	1.6	0.5	8.8	1.5	0.8
Increase in Stage (ft)	0.1	0.0	0.0	0.3	0.1	0.0	0.4	0.2	0.0
Ten Mile Reach									
Increase in Peak Q (%)	6.2	0.4	0.3	14.5	3.4	1.5	15.8	3.8	1.5
Increase in Stage (ft)	0.3	0.0	0.0	0.4	0.3	0.2	0.7	0.4	0.2

3.3 Unsteady Flow Analyses

Effects of encroachments on the magnitude and timing of the flood peak were determined through unsteady flow analysis using the "Gradually Varied Unsteady Flow Profiles" computer program. Hydrographs were routed down a 6.06 mile long channel, using a stage-discharge relationship at the downstream end to define the downstream boundary condition. The index point for hydrograph comparison was 5.4 miles from the upstream end of the channel. This location was judged to be far enough away from the downstream boundary to not be significantly affected by it.

The flood hydrographs were triangular in shape for simplicity. A comparison between an original hydrograph as computed by the HEC-1 computer program and its triangular approximation is shown in Figure 3.3. This hydrograph is Hydrograph 3 of Figure 2.5.

Tabulation of Results. Table 3.2 gives the results of the unsteady flow calculations for the five hydrographs of Figure 2.5. The initial flood plain widths were 350, 600, 800, 1200, and 5000 ft, while the corresponding widths giving a 1.00 ft rise for steady flow were 292, 490, 652, 960, and 3100 ft. In general, the increase in maximum flood stage computed by the unsteady flow analysis is close to one foot, except for those cases where the flood plain volume is large with respect to the volume of the flood. In the latter case, the increase is usually less than one foot.

Discussions of other aspects of the results are given in the following paragraphs.

Effects of Hydrograph Shape. The effect of hydrograph shape on flood attenuation was examined in this study using the five triangular hydrographs shown in Figure 2.5. The relative flood peak magnitude, Q_p/Q_0 , is given in Figures 3.4 and 3.5 as a function of valley width W for each hydrograph (Q_p = peak flow at point 5.4 miles from upstream end of channel; Q_0 = peak flow at upstream end).

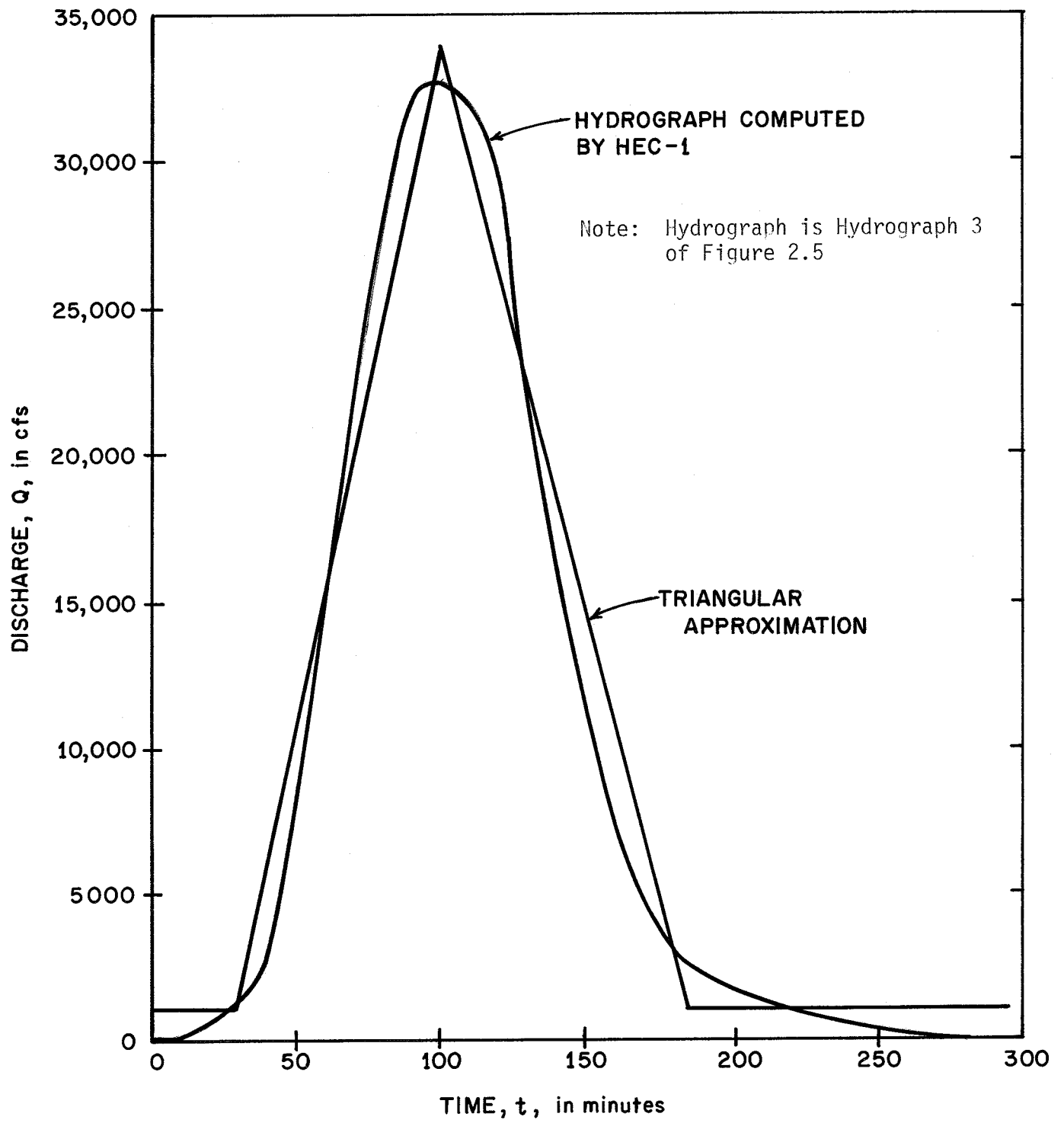

FIGURE 3.3 Approximation to Hydrograph Using a Triangular Shape

Table 3.2
RESULTS OF UNSTEADY FLOW ANALYSIS

River Slope, S = 0.001				River Slope, S = 0.0001			
W (ft)	Q _p (cfs)	t _p (min)	y _{max} (ft)	W (ft)	Q _p (cfs)	t _p (min)	y _{max} (ft)
HYDROGRAPH 1				HYDROGRAPH 1			
292	22671	60	8.18	292	15277	64	11.60
350	22139	68	7.33	350	14492	72	9.97
490	21109	68	5.92	490	12743	92	7.26
600	20893	80	5.14	600	11726	96	5.82
652	20493	84	4.83	652	11318	100	5.28
800	20025	100	4.10	800	10243	120	4.08
960	18931	116	3.59	960	8882	144	3.21
1200	17271	140	2.97	1200	7180	152	2.34
3100	14727	272	0.89				
5200	3990	736	0.00				
HYDROGRAPH 2				HYDROGRAPH 2			
292	23883	48	8.57	292	16154	52	11.89
350	23372	56	7.67	350	15293	60	10.81
490	22006	56	6.19	490	13350	80	7.35
600	22074	68	5.36	600	12307	84	5.85
652	21659	76	5.03	652	11834	88	5.30
800	21068	88	4.29	800	10610	108	4.09
960	19908	104	3.76	960	9074	128	3.22
1200	18043	128	3.10	1200	7300	136	2.34
3100	14959	256	0.94				
5200	3983	720	0.00				
HYDROGRAPH 3				HYDROGRAPH 3			
292	25510	36	9.13	292	17486	36	12.34
350	24995	40	8.17	350	16557	44	10.50
490	23638	56	6.58	490	14349	60	7.45
600	23558	52	5.69	600	13241	64	5.89
652	23525	56	5.33	652	12693	68	5.50
800	22460	68	4.55	800	11230	84	4.10
960	21494	84	4.00	960	9350	104	3.22
1200	19321	104	3.28	1200	7468	116	2.34
3100	15373	236	0.99				
5000	3983	708	0.00				
HYDROGRAPH 4				HYDROGRAPH 4			
292	27070	24	9.68	292	18938	20	12.95
350	26532	28	8.69	350	18196	24	10.86
490	25433	36	7.01	490	15854	36	7.50
600	24086	48	6.10	600	14551	40	5.91
652	24428	36	5.70	652	13897	44	5.34
800	24637	48	4.86	800	11886	60	4.11
960	23177	60	4.27	960	9577	76	3.23
1200	20717	80	3.47	1200	7557	88	2.34
3100	15593	208	1.03				
5000	3984	672	0.00				
HYDROGRAPH 5				HYDROGRAPH 5			
292	27492	16	9.80	292	19118	16	13.14
350	26995	20	8.81	350	18930	16	10.90
490	25661	24	7.10	490	16617	24	7.51
600	24652	32	6.19	600	14962	28	5.91
652	23743	36	5.79	652	14233	32	5.34
800	24364	40	4.82	800	11988	44	4.11
960	23918	48	4.34	960	9586	60	3.22
1200	21011	68	3.51	1200	7555	76	2.34
3100	15617	200	1.03				
5000	3975	672	0.00				

The plot in Figure 3.4 shows that in narrow valleys the hydrograph shape is an important factor in flood wave attenuation for the flatter river slope ($S = 0.0001$). When the peak occurs early in the flood period, the attenuation is greater than when the peak occurs later in the flood. In the case of the early peak, flow from the region of the hydrograph peak supplies the volume to fill the flood plain storage, while in the delayed-peak case, a good portion of the flood plain storage has already been filled when the peak of the flood arrives. In wide valleys with the flatter slope ($S = 0.0001$) hydrograph shape becomes less important.

For the river channels with the steeper slope ($S = 0.001$) the effects of hydrograph shape are relatively independent of the valley width. Hydrographs with early peaks experience more attenuation than those with late peaks for all valley widths simulated. The sample routed hydrographs shown in Figure 3.6 for Hydrograph 1 (early peak) and Hydrograph 5 (late peak) illustrate the difference in the transformation of the hydrographs for the two cases for a valley width of 292 ft.

Increase in Flood Peak Flow. When the water surface rise was limited to one foot the increase in flood peak flows was usually less than 10 percent, except where the flood plain was initially very wide and the encroachment large. In these cases the increase in peak flow can be quite large.

Figure 3.7 shows the increase in peak flow for the routed hydrographs for the case where the encroachment causes a 1.00 ft rise in the water level. The increase is much less for a given reduction in flood plain area for the steeper slope ($S = 0.001$) than the flatter slope ($S = 0.0001$). To keep the increase in peak flow at 10 percent or less, the reduction in flood plain area

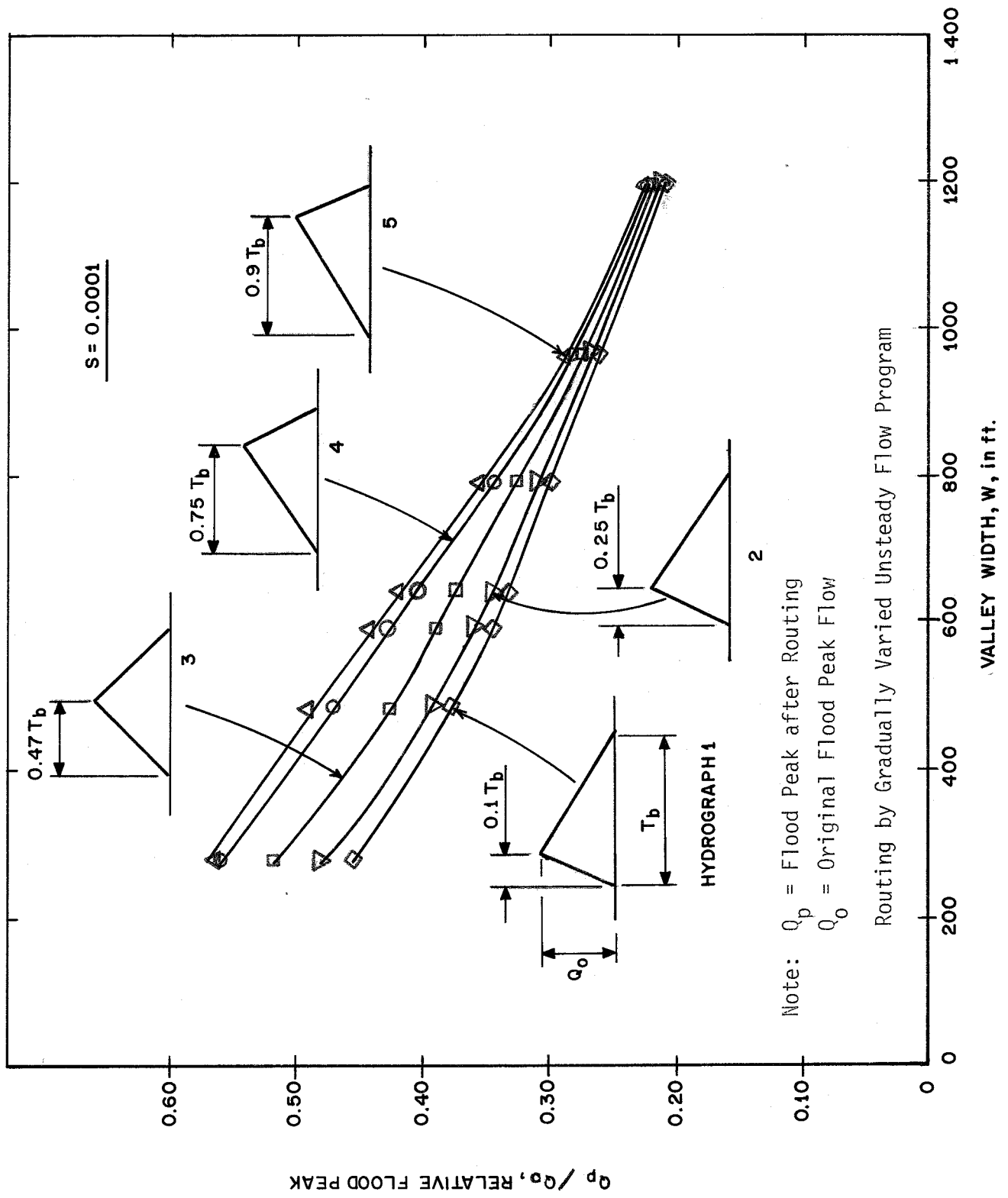

FIGURE 3.4 Relative Flood Peak as a Function of Valley Width for $S = 0.0001$

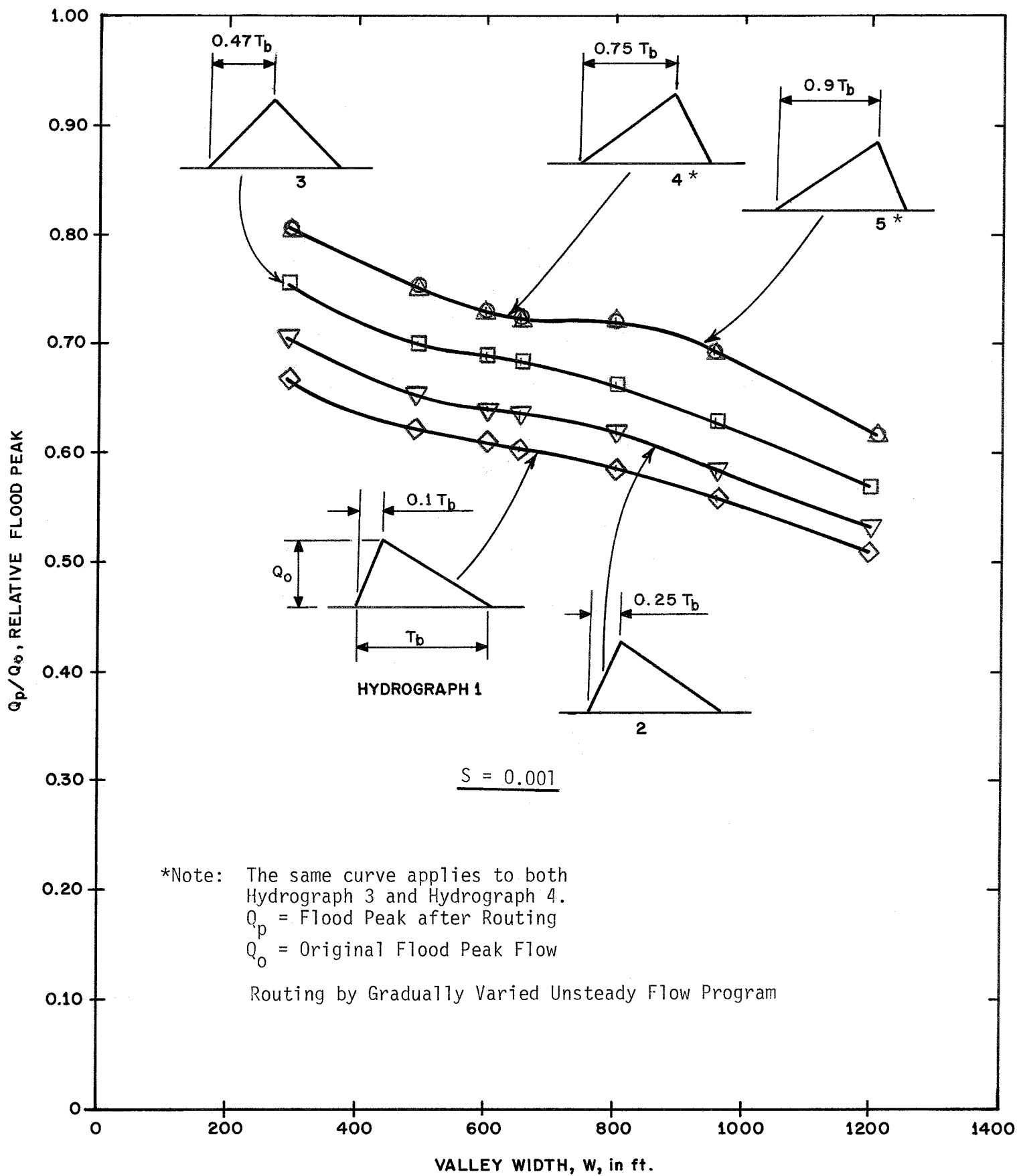

FIGURE 3.5 Relative Flood Peak as a Function of Valley Width for $S = 0.001$

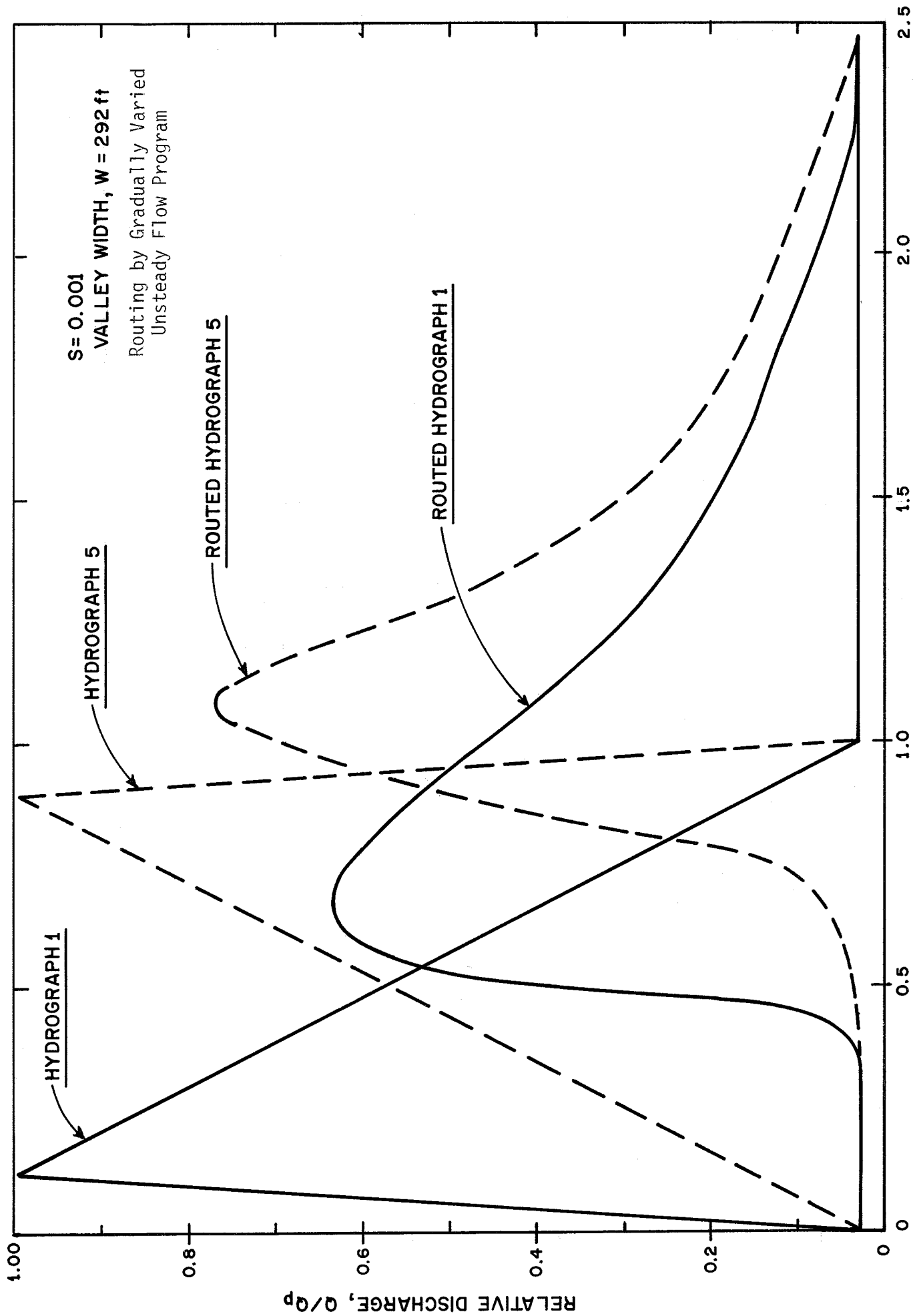

FIGURE 3.6 Effect of Timing of Peak on Routed Hydrograph Shape

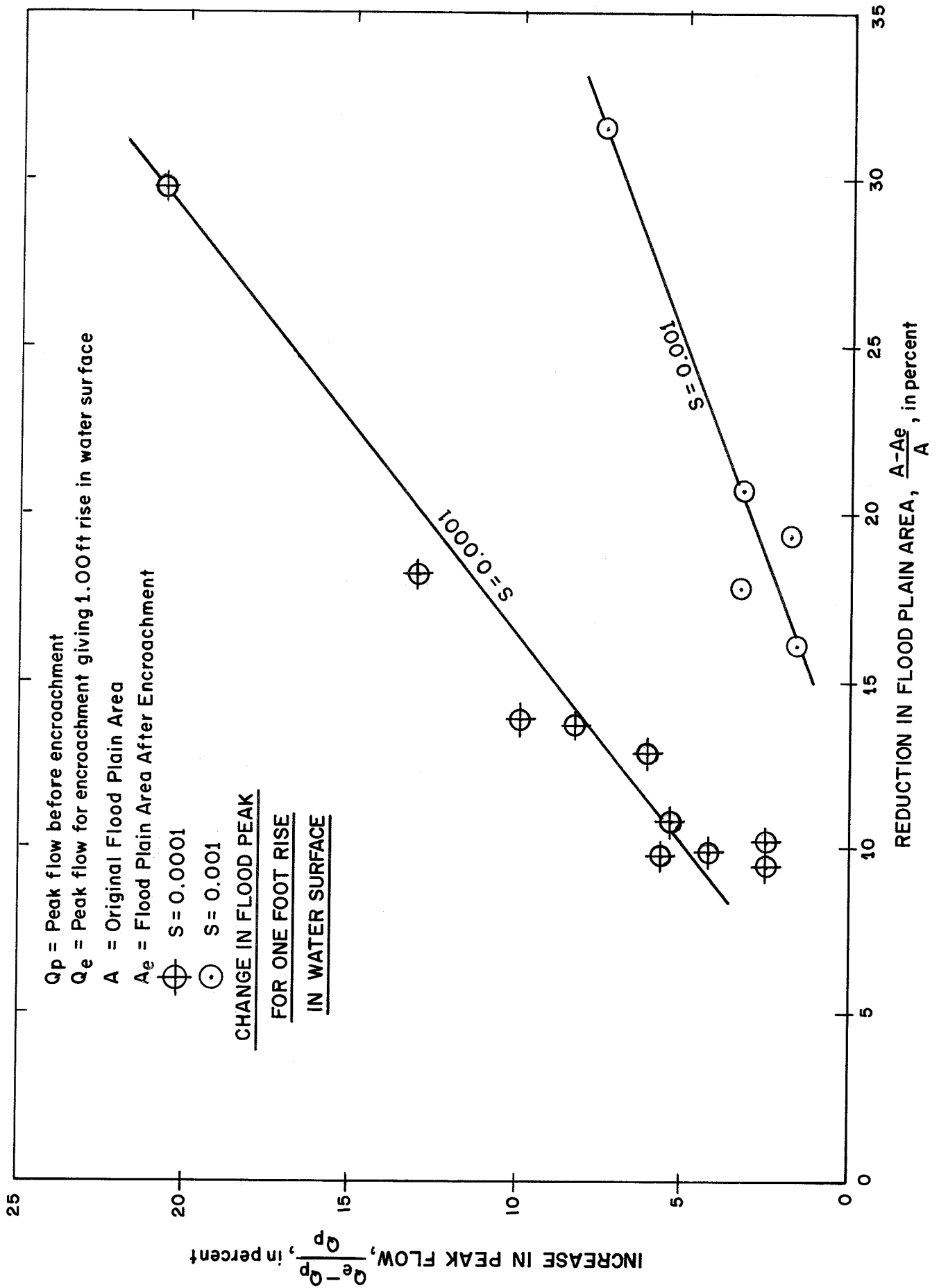

FIGURE 3.7 Increase in Flood Peak Flow as a Function of the Reduction in Flood Plain Area

should be limited to approximately 15 percent for the flatter slopes, while much greater amounts of the flood plain can be occupied for steeper slopes for the same increase in peak flow.

Effect of Channel Slope. The effect of channel slope on the routed flood hydrograph is shown in Figures 3.8 and 3.9. Figure 3.8 illustrates the effect of the slope on hydrograph shape for the case of a 292 ft wide channel using Hydrograph 1 of Figure 2.5. In the steeper channel ($S = 0.001$) the attenuation is much less, the arrival time of the peak sooner, and the flow subsides much more rapidly than for the case when the slope is flatter ($S = 0.0001$). Figure 3.9 indicates the relationship between computed flood peak flow and valley width for the two slopes used in this study. The hydrograph used in this comparison is Hydrograph 3 (Figure 2.5). For the cases studied here, the hydrograph for the flatter slope was attenuated less.

The maximum water depth on the flood plain also depends on the river slope as well as valley width. Figure 3.10 gives a plot of the maximum water depth above the local river bottom as a function of valley width for the two river slopes used in this study. The data for Figure 3.10 are from the same computer simulations as used for the data for Figure 3.9. For this hydrograph, the water depths on the flood plain are greater for flatter slopes and the narrower valleys, while for wider valleys the depths are greater for the steeper slopes.

Another indication of the influence of the channel slope on the behavior of the flood wave is given in Figure 3.11, which shows the variation in water level in the river with time for the two slopes: $S = 0.001$ and $S = 0.0001$. The ordinates of the two curves are plotted relative to the original water surface elevation (the depth for the case of the 0.0001 slope is about 3.2 ft greater at the beginning of the hydrograph). For this particular case, the total rise in

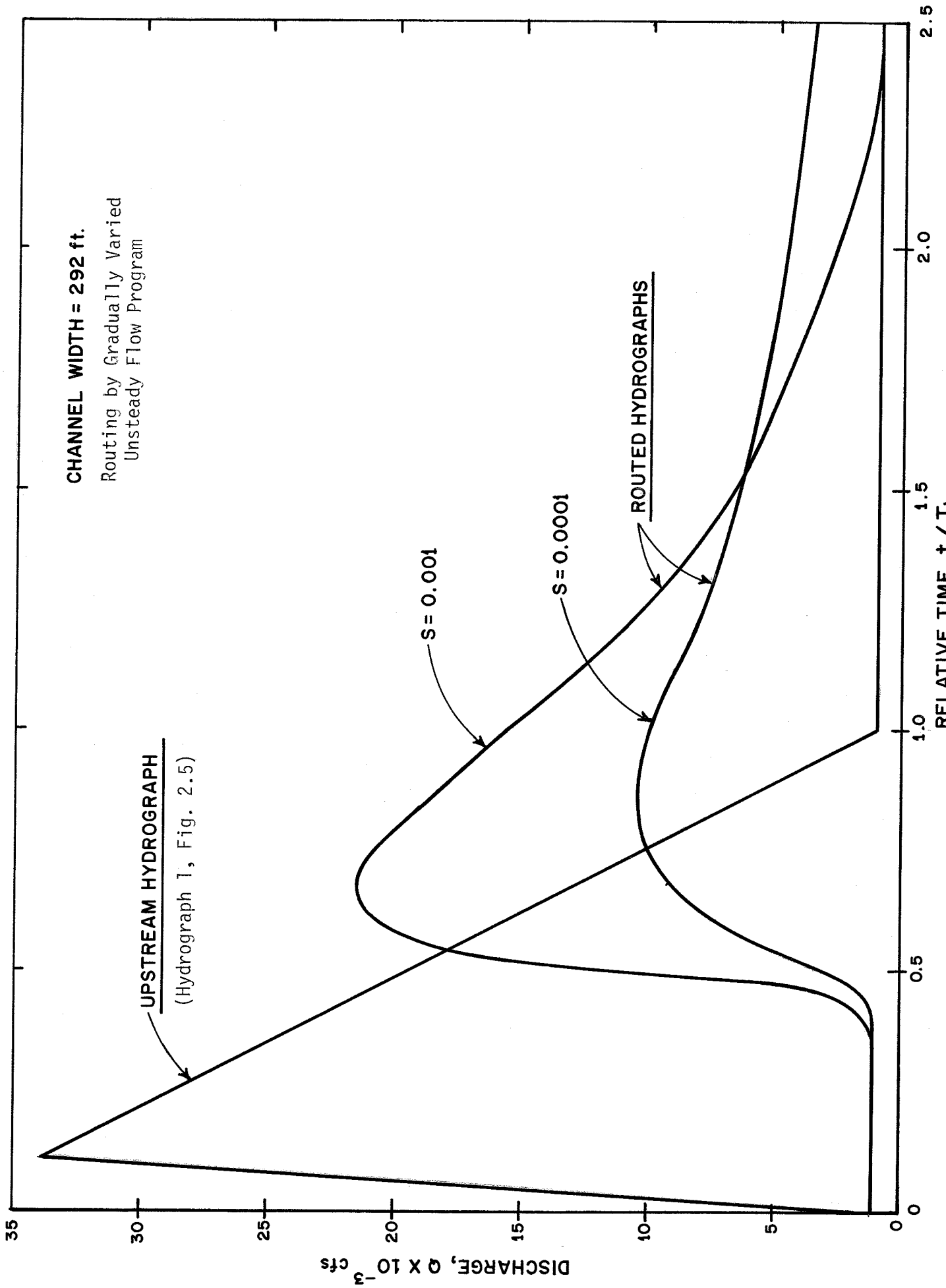

FIGURE 3.8 Effect of Slope on Routed Hydrographs

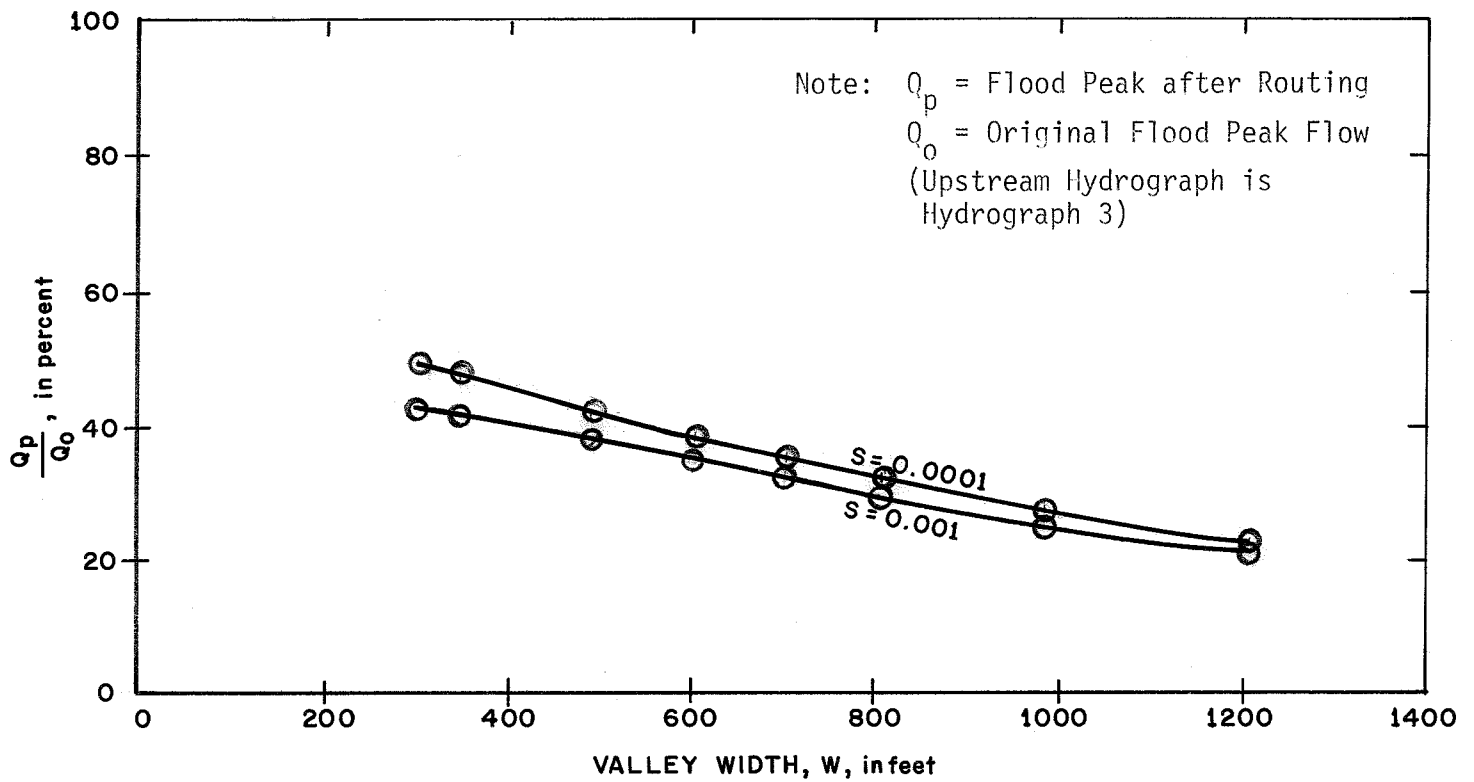

FIGURE 3.9 Flood Peak Flow as a Function of Valley Width for Two River Slopes

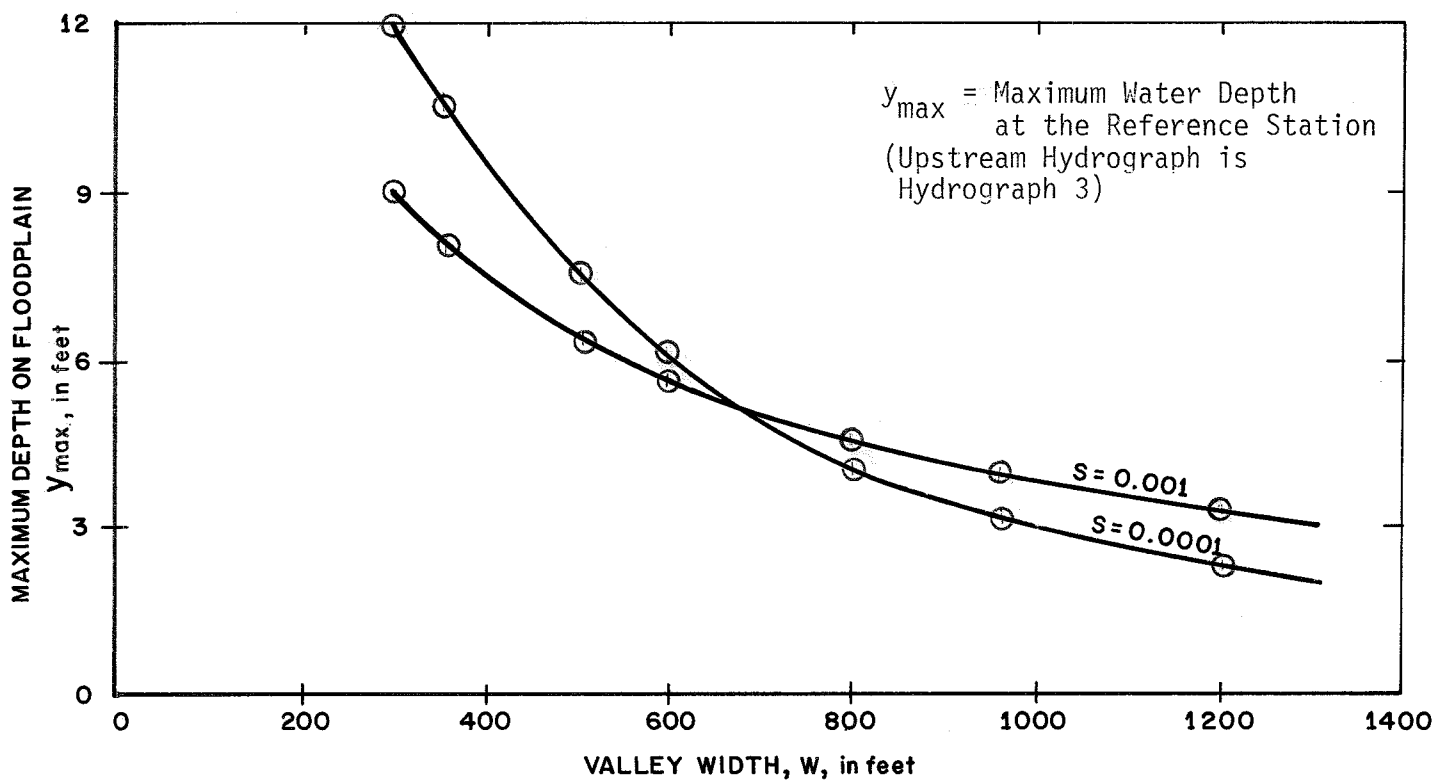

FIGURE 3.10 Maximum Water Depth on Flood Plain as a Function of Valley Width for Two River Slopes

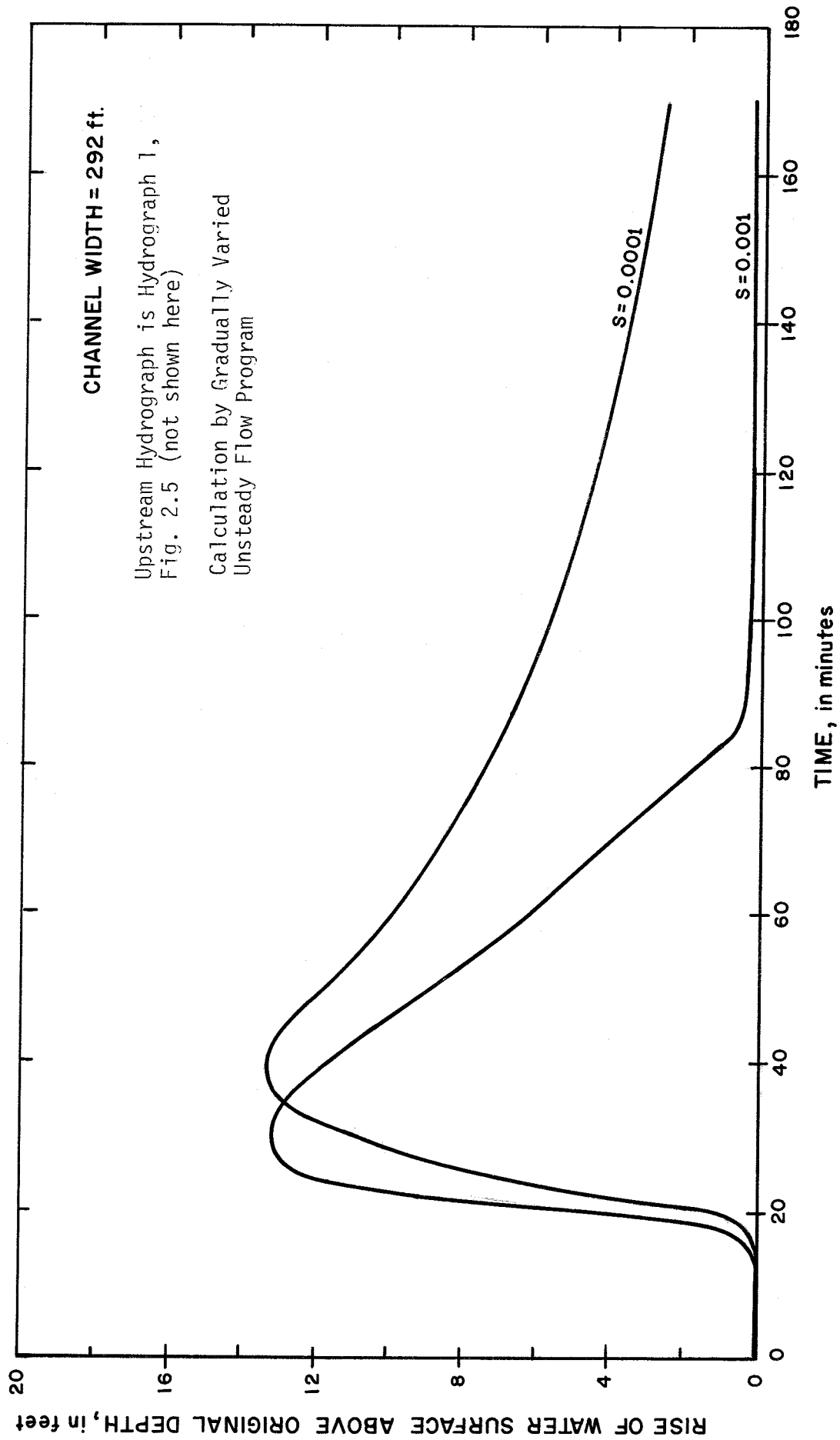

FIGURE 3.11 Effect of Channel Slope on Stage Hydrograph

water level is about the same for the two slopes; however, this will not always be the case. The stage hydrographs for the steeper river peak earlier and subside more rapidly in a manner similar to the discharge hydrographs of Figure 3.8. For flatter slopes, water remains in storage on the flood plain for much greater lengths of time.

Flood Peak Timing. The timing of the flood peak is strongly affected by the degree of encroachment. In general, the flood peak arrives significantly earlier as a result of a reduction of flood plain storage. If tributary flow or high local inflows are important for the stream being studied, a change in timing of the peak could have major consequences. If it is expected that this will happen, an analysis of this effect should be made by routing and combining hydrographs.

The effect of valley width on the arrival time of the flood peak is shown in Figure 3.12 for Hydrograph 3 for two river slopes. In narrow valleys the slope does not appear to influence the peak timing greatly. For wider valleys, the flood peak arrives sooner in the steeper slope case, as would be expected.

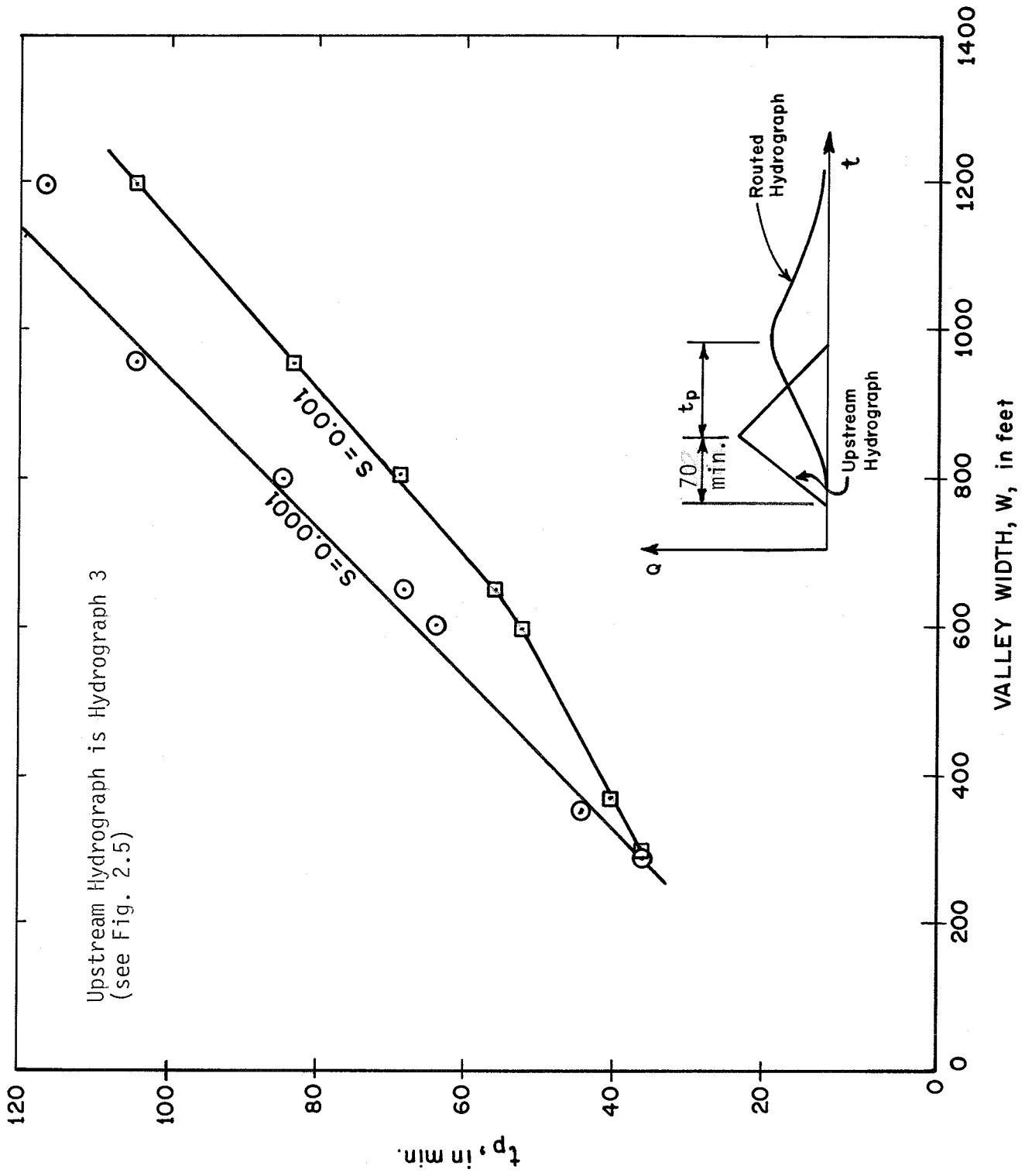

FIGURE 3.12 Effect of Valley Width on Timing of Hydrograph Peak

4. APPLICATION OF RESULTS

4.1 Procedures and Guidelines

Each river and its flood plain present a unique situation, and at this point no specific guidelines for evaluating individual cases can be stated. Each encroachment problem must be considered by itself.

However, within the range of conditions prescribed by the Flood Insurance Administration's guidelines (a one-foot maximum rise in water surface), it is possible to draw some general conclusions. As shown by the unsteady flow analyses discussed in the previous section, in many cases when the rise in water level is restricted to no more than one foot, the increase in the flood peak flow is small - frequently less than ten percent. When this relatively minor difference in flow is considered in the light of the uncertainties which are present in other aspects of the hydrologic and hydraulic descriptions of the problem (such as the flood plain geometry, roughness parameters, and the precise value of the flow magnitude) it seems reasonable to ignore the increase in peak discharge.

The exceptions to this general rule are for the cases of rivers with very flat slopes and with encroachments which remove large amounts of the flood plain area. In these cases there can be a substantial increase in the flood peak magnitude. Analysis of the changed hydraulic conditions must be made in these situations because the downstream hydrologic conditions (the discharge-frequency relationship) will be changed. In most cases, standard flood routing techniques can be used to compute a new hydrograph for the downstream end of the reach. If only the peak discharge is needed, the method developed by the Natural Environmental Research Council of Great Britain (1975) can be used (see Appendix).

The best results can be obtained when the flood routing is done using the full equations of unsteady open channel flow (St. Venant equations) as shown in the studies by Huntington (1974) and Fread (1976). However, this type of analysis requires a much greater effort in terms of personnel time, is more expensive in terms of computer costs, and requires the hydrologist to have some background in numerical analysis techniques.

Physical models have also been successfully used to evaluate the effects of encroachments. However, physical hydraulic models are costly to construct and test, and the time required to make a physical model study is usually long when compared to a computer modeling effort. When an existing model is available, studies of this type become competitive with numerical modeling studies and often produce more accurate results.

4.2 Other Considerations

As discussed above, in most cases when the flood plain encroachment causes no more than a 1 foot rise in the maximum water level, the corresponding increase in peak flow is usually minor. In addition, in practice the actual increase will usually be less because the full proposed encroachment often does not occur. As pointed out by Goddard (1979), the actual development on a flood plain is such that significant flood plain storage is still available even though the floodway fringe is developed. Also, the encroachment limits selected usually produce a water surface rise that is less than 1.0 ft.

Even though the actual effects of encroachments on flood hydrographs will likely be less than the anticipated amounts, this cannot be relied upon in floodway analysis. However, it does provide a safety factor to help ensure that the actual water surface rise does not exceed the designed amount (say for example, the one foot used for FIA studies).

4.3 Examples

Some examples are presented to illustrate the circumstances for which peak-flow increases can be ignored and to indicate when additional analysis must be done. As discussed above, each case must be considered by itself, and specific numerical guidelines cannot be given.

Example 1 - Steep River, Minor Encroachments

A flood-plain study is being made for a river which has an average slope of five feet per mile. The encroachment limits which give a maximum rise in water level of one foot for the 100-year flood result in a removal of ten percent of the flood plain along a four mile reach of the river. The major floods in this river are snowmelt floods which last for several days. The question to be considered is: will there be significant changes in the flood peak in the areas downstream from this encroachment?

In this case the removal of a relatively small volume from flood plain storage will have only a minor effect on the flood hydrograph, especially since the river slope is not flat ($S \approx 0.001$). In addition, the hydrograph is not sharply peaked, further reducing the attenuation effects. Making a detailed flood routing analysis is not warranted, therefore.

Example 2 - Large River, Major Encroachments

The Missouri River is joined by the Kansas River at Kansas City, Kansas and Missouri. Flood walls and levees along the top banks of the rivers are used to protect these cities against flooding. It was proposed to construct a series of agricultural levees along the river below Kansas City which would remove many square miles of flood plain area. Because major amounts of flood plain area would be no longer available, the effect of these levees on the flood conditions at Kansas City would be great. In the reach of the river that

was studied, the flood plain is from 1-1/2 to 11 miles wide and about 300 miles long. The levees limit the floodway width from a minimum of 3,000 feet to about 5,000 feet.

An evaluation of the effects of these encroachments was done using a physical model, the Mississippi Basin Model of the U.S. Army Corps of Engineers (WES, 1955). In this study it was found that for a design flow of over 500,000 cfs stages were increased by 3 to 5 feet along the river as a consequence of these levees. These stages were measured under steady flow conditions; the heights would have been somewhat less if they corresponded to maximum values resulting from a hydrograph routed through the model.

In another test, a flood hydrograph with a peak discharge of 300,000 cfs was compared with a steady flow condition of 300,000 cfs. Stages for the steady flows varied from 0.5 feet to 1.5 feet higher than for the hydrograph flows. In general, simulations using steady flows will give higher flood stages than for unsteady flow conditions.

Example 3 - Local Encroachment

In a study of the effects of storage on flood magnitudes and stages for the North Branch of the Chicago River using the Hydrocomp Simulation Program (HSP model), the effects of a land fill 0.8 miles long by 0.4 miles wide were investigated (Hydrocomp, Inc., 1973). This is about 3 percent of the effective flood plain storage capacity. The channel slope is 3.8 feet per mile. This fill removes about 140 ac-ft of flood plain storage for the 100-year flood.

At the land fill site, the computed peak discharge was increased 14 percent with an increase in the stage of 1.9 feet. At relatively short distances downstream the effects were negligible, however, with no apparent change in stage and less than 1 percent increase in peak discharge.

Individual fill projects of this type usually do not displace large amounts of flood plain storage, and thus their influences are small, except in their immediate vicinity. The effects are cumulative, however, and several land fills of this type in combination may cause significant increases in discharge downstream.

5. REFERENCES

1. Abbott, M. B., G. S. Rodenhuis and A. Verway (1971), "Further Development of the Implicit Difference Scheme for Flood Wave Calculation," Proceedings, 14th Congress, International Association for Hydraulic Research, Paris, pp. 310-1-310-4.
2. Dewey and Kropper, Engineers (1964), "Effect of Loss of Valley Storage Due to Encroachment - Connecticut River," Report to Connecticut Water Resources Commission, Hartford, Connecticut, April, 15 pp.
3. DiSilvio, G. (1969), "Flood Wave Modification Along Prismatic Channels," Journal of the Hydraulics Division, ASCE, Vol. 95, No. HY5, September, pp. 1589-1614.
4. Federal Insurance Administration (1977), Flood Insurance Study, Guidelines and Specifications, U. S. Department of Housing and Urban Development, Washington, D. C.
5. Fread, D. L. (1976), "Flood Routing in Meandering Rivers with Flood Plains," RIVERS '76, Symposium on Inland Waterways for Navigation, Flood Control and Water Diversions, Fort Collins, Colorado, ASCE, NY, August, pp. 16-35.
6. Garrison, J. M., J. P. Granju, and J. T. Price (1969), "Unsteady Flow Simulation in Rivers and Reservoirs," Journal of the Hydraulics Division, ASCE, Vol. 95, No. HY5, September, pp. 1559-1576.
7. Goddard, James E. (1979), "Origin and Rationale of Criterion Used in Designating Floodways," Flood Insurance Administration, U. S. Department of Housing and Urban Development, Washington, D. C.
8. Grushevsky, M. S. (1967), "Flood Plain Influence on Flood Wave Propagation Along a River," International Symposium on Floods and their Computation, Vol. II, IASH-UNESCO-WMO, Publication No. 85, pp. 745-754.
9. Hayami, S. (1951), "On the Propagation of Flood Waves," Bulletin No. 1, Disaster Prevention Research Institute, Kyoto University, Japan, December, pp. 1-15.
10. Henderson, F. M. (1966), Open Channel Flow, MacMillan Publishing Co., Inc., New York.
11. Huang, Y. A., and R. K. Gaynor (1977), "Effects of Stream Channel Improvements on Downstream Floods," Research Report No. 102, Water Resources Institute, University of Kentucky, Lexington, 182 pp.
12. Huntington, S. W. (1974), Simulation of Flood Waves in Channels, Dissertation submitted for the Degree of Doctor of Philosophy in Engineering, University of Bristol, England, April, 138 pp.

13. Hwang, L-S, and E. M. Laursen (1963), "Shear Measurement Technique for Rough Surfaces," Journal of the Hydraulics Division, HY2, March, pp. 19-37.
14. Hydrocomp, Inc. (1973), "Analysis of the Effects of Storage on Flood Magnitude and Stage in the North Branch of the Chicago River," Report to Northeastern Illinois Planning Commission, August, 72 pp.
15. Hydrologic Engineering Center (1973), "HEC-1 Flood Hydrograph Package," Users Manual, Computer Program 723-X6-L2010, U. S. Army Corps of Engineers, Davis, California, January.
16. Hydrologic Engineering Center (1977), "Gradually Varied Unsteady Flow Profiles," Users Manual, Computer Program 723-G2-L7450, U. S. Army Corps of Engineers, Davis, California, August.
17. Hydrologic Engineering Center (1979), "HEC-2 Water Surface Profiles," Users Manual, Computer Program 723-X6-L202A, U. S. Army Corps of Engineers, Davis, California, August.
18. Johnson, B. H., and P. K. Senter (1977), "Effect of Loss of Valley Storage in the Cannelton Pool on Ohio River Flood Heights," Miscellaneous Paper H-77-7, U. S. Army Engineer Waterways Experiment Station, Vicksburg, Mississippi, June, 33 pp.
19. Liggett, J. A. (1968), "Mathematical Flow Determination in Open Channels," Journal of the Engineering Mechanics Division, ASCE, Vol. 94, No. EM4, August, pp. 947-963.
20. Malhotra, G. P. (1968), "Computing Overbank Flows," Civil Engineering, No. 3, March.
21. Paslawski, Z., and K. Olejnik (1967), "The Influence of the Primordial Valleys Upon the Transformation of Flood Waves of the Warta Rivers," International Symposium on Floods and Their Computation, Vol. II, IASH-UNESCO-WMO, Publication No. 85, pp. 767-772.
22. Natural Environment Research Council (1975), Flood Studies Report, Vol. 3, "Flood Routing Studies," London, England.
23. Radojkovic, M. (1976), "Mathematical Modeling of Rivers with Flood Plains," Rivers 76, Proceedings, Symposium on Inland Waterways for Navigation, Flood Control and Water Diversion, Fort Collins, Colorado, ASCE, New York, pp. 56-64.
24. Strelkoff, T. (1969), "One-Dimensional Equations of Open-Channel Flow," Journal of the Hydraulics Division, ASCE, Vol. 95, No. HY3, May, pp. 861-876.
25. Toebes, G. H., and A. A. Sooky (1967), "Hydraulics of Meandering Rivers with Flood Plains," Journal of the Waterways and Harbors Division, ASCE, Vol. 93, WW2, May, pp. 213-236.

26. Waterways Experiment Station (1955a), "Effects of Agricultural Levees on Design Flood Profiles for Kansas City Local Protection," Mississippi Basin Model Report No. 32-1, U. S. Army Corps of Engineers, Vicksburg, Mississippi, May, 6 pp + 135 figs.
27. Waterways Experiment Station (1955b), "Effects on Flood Heights of Levee, Railroad, and Highway Fills in the Flood Plain of the Missouri Rivers," Mississippi Basin Model Report No. 92-1, U. S. Army Corps of Engineers, Vicksburg, Mississippi, October, 4 pp + 59 figs.
28. Waterways Experiment Station (1959), "Tests for Reevaluation of Missouri River Agricultural Levees in the Kansas City District," Mississippi River Basin Model Report No. 32-2, U. S. Army Corps of Engineers, Vicksburg, Mississippi, December, 9 pp, 103 plates.
29. Waterways Experiment Station (1971), "Effects of Height and Alignment of Levees at Confluence of Missouri and Mississippi Rivers - Hydraulic Model Investigation," Mississippi Basin Model Report No. 38-1, U. S. Army Corps of Engineers, Vicksburg, Mississippi, November, 29 pp.
30. Weinmann, P. E., and E. M. Laursen (1979), "Approximate Flood Routing Methods: A Review," Journal of the Hydraulics Divisions, ASCE, Vol. 105, No. HY12, December, pp. 1521-1536.
31. Wright, R. R., and R. M. Carstens (1970), "Linear-Momentum Flux to Overbank Section," Journal of the Hydraulics Division, ASCE, Vol. 96, HY9, September, pp. 1781-1794.
32. Yen, C-L and E. D. Overton (1973), "Shape Effects on Resistance in Flood Plain Channel," Journal of the Hydraulics Division, ASCE, Vol. 99, HY1, January, pp. 219-238.

APPENDIX

APPENDIX

FACTORS AFFECTING FLOOD WAVE ATTENUATION

The description of flood routing procedures developed by the Natural Environment Research Council (1975) for use on British rivers provides an excellent source of information on factors affecting flood wave attenuation as well as general background on flood routing methods. The "convection-diffusion equation" is used for flood routing. The equation is written in a form which permits direct computation of flood wave attenuation along a river reach as a function of hydrograph and flood plain and river channel parameters. A brief summary of the assumptions used in its derivation, as well as limitations on its use, are discussed here.

As with most flood routing procedures, the starting point is the St. Venant equations. The following assumptions can be made to permit simplification of the equations:

1. River slopes are on the order of 0.001 or steeper. This implies that the momentum of the flow is governed primarily by the bottom and friction slopes.
2. Acceleration and convection of momentum terms are small and can be ignored.
3. Contribution of momentum from lateral inflows can be ignored.
4. The volume of lateral inflow is small relative to channel flow.

The resulting simplified equations of motion are:

$$\frac{\partial A}{\partial t} + \frac{\partial Q}{\partial x} = q \quad (1)$$

$$S - \frac{\partial y}{\partial x} - \frac{Q^2 n^2}{A^2 R^{4/3}} = 0 \quad (2)$$

where A is cross sectional flow area, t is time, Q is flow, x is direction of flow, q is lateral inflow per unit length of channel, S is channel slope, y is flow depth, n is Manning's roughness parameter, and R is the hydraulic radius.

Further simplifications can be made if the following assumptions hold:

1. The computation reach is short so that changes in flow, wave speed, and channel slope are small (changes are less than 10 percent, say)
2. The flood wave speed is governed primarily by the main channel flow.

The simplifications to the equations of motion enables routing of the peak flow without considering the full hydrograph. Such an equation is of interest here because it illustrates the factors which influence flood wave attenuation.

At the flood peak $\partial Q/\partial t = 0$. For a sufficiently short river reach this condition also holds along the entire reach. If lateral inflow is assumed to be negligible, it can be shown that the attenuation of the flood wave, Q^* is given by:

$$Q^* = \frac{\alpha Q_1}{\bar{c}_1^3} \left| \frac{d^2 Q_1}{dt^2} \right| \quad (3)$$

where the subscript 1 denotes values associated with the peak flow at the upstream end of the reach. Thus, Q_1 is the upstream peak flow, and Q_2 is the downstream peak flow, so that $Q^* = Q_1 - Q_2$; α is an attenuation parameter for the reach, \bar{c}_1 is the mean flood wave speed for the reach: $\bar{c}_1 = L/T_p$, where L is the reach length and T_p is the time difference between peaks at the upstream and downstream ends of the reach; $d^2 Q/dt^2$ is the second derivative of the flow with respect to time at the peak. This last term gives a measure of the

hydrograph curvature at the peak. The reader is referred to Natural Environment Research Council (1975) for the details of the derivation and procedures for application to flood routing studies. This publication also contains some comparisons between this method and other routing procedures.

The attenuation parameter α is a function of width and length of the flood plain plus river channel and of the river slope. Because the river width and slope are not constant, the routing reach can be divided into subreaches.

If M subreaches are used

$$\alpha(Q) = \frac{1}{2} \left\{ \frac{1}{L} \sum_{m=1}^M \frac{P_m}{S_m^{1/3}} \right\}^{-3} \sum_{m=1}^M \frac{P_m^2}{L_m S_m^2} \quad (4)$$

where P_m is the plan area of the inundated flood plain and channel for the m-th subreach, L_m and S_m are corresponding lengths and channel slopes.

The curvature of the peak of the upstream discharge hydrograph is approximated by:

$$\frac{d^2 Q_1}{dt^2} = \frac{Q_{\Delta t} + Q_{-\Delta t} - 2Q_1}{(\Delta t)^2} \quad (5)$$

where Q_1 is flow at the peak, $Q_{-\Delta t}$ and $Q_{\Delta t}$ are the flows at some time Δt before and after the peak respectively.

The flood wave speed $\bar{c}(Q)$ is defined as the average speed along the reach at the peak discharge. In the derivation of Equation (3), \bar{c} was based on a peak flow without attenuation. When there is attenuation, \bar{c} depends not only on the observed flood wave speed L/T_p , but also on the shape of the discharge hydrograph. It is recommended in the Natural Environment Research Council report that if the attenuation is greater than 10 percent ($Q^*/Q_1 \times 0.1$)

then \bar{c} should be computed by the expression

$$\bar{c} = \frac{L}{T_p} - \frac{2\alpha}{L^2} Q^* \quad (6)$$

The purpose of this discussion is to show what factors influence the attenuation of the flood wave. Under conditions which meet the assumptions listed above, the important factors as indicated by Equation (3) are:

1. Hydrograph shape, especially curvature at the peak,
2. Flood plain width,
3. River slope, and
4. Flood wave speed.