

The
FIELD ARTILLERY
Journal



IN THIS ISSUE:

Artillery in Bataan--II

JUNE, 1942

BLITZKRIEG

By F. O. MIKSCHKE

will shortly appear in an American edition under the title

ATTACK

★ One of the most stimulating and important books we have seen, it has met with wide favor abroad. We are glad to help make it available in this country, and to announce its price as

\$2.50

but can not state now whether or not a discount can be allowed.

All orders will be filled immediately upon publication.

Address

**THE
U. S. FIELD ARTILLERY ASSOCIATION**
1218 Connecticut Avenue Washington, D. C.

SIGNPOSTS OF EXPERIENCE

Every word of *Signposts of Experience* has an application to what we are doing today. Its timeliness can scarcely be overstated. It will be read through with profit and interest, and then become an addition to your military library which you will refer to again and again.

\$2.75 postpaid (see page 490)

OFFICER CANDIDATES:

These books will help you:

- Officers' Guide** **\$2.50**
7th edition just off the press.
- FAB-161, Gunnery** **.60**
(For sale only to members of the military service.)
- Company Administration and Personnel Records**
- Cloth** **2.00**
Paper **1.50**
An easy, authoritative reference for the multitude of problems confronting all commissioned and noncommissioned officers of a battery.
- Drill and Ceremonies for Field Artillery** **1.00**
Based on the latest official publications. Added are numerous excellent illustrations which greatly clarify the text.
- Soldier's Handbook for Field Artillery** **.50**
Customs, practices, and language of the Field Artillery have been added to FM 21 100 to give the soldier the full story and traditions of the field artillery.
- How to Produce an Efficient Firing Battery Single copy** **.20**
Lots of 10 or more **.15**
Practical advice for the battery executive and all members of the firing battery. Reprinted from the Field Artillery Journal.
- Battery Duties: A Practical List** **.25**
- Recommended background material:**
- Signposts of Experience** **\$2.75**
What the Citizen Should Know About the Army **2.50**

For discounts and more complete descriptions of the above books see our larger advertisements in this issue. Above all—

SUBSCRIBE TO

- The Field Artillery Journal** **3.00**
(For 1941 the pages of its twelve issues totalled one thousand—the equal of several large books.)

THE SOLDIER'S HANDBOOK 50c

(See discount offer on page 490)

The tremendous personnel increase in all branches of the Army has made a quick, accurate guide for the newcomer a vital part of soldier training. The Field Artillery SOLDIER'S HANDBOOK is the answer. FM 21-100 is given in its entirety. In addition, customs, practices and language of the Field Artillery have been added to bring home to the soldier the organization, description of materiel, and the traditions of the U. S. Field Artillery. Many an old timer will be glad to have this data in such handy form.

ORDER THROUGH

U. S. FIELD ARTILLERY ASSOCIATION
1218 Connecticut Avenue, Washington, D. C.

MAJOR JOHN E. COLEMAN, *Editor*
 LIEUT. A. V. RUTLEDGE, *Assistant*
 LENNA PEDIGO, *Business Manager*

The Field Artillery Journal

"Today's Field Artillery Journal is tomorrow's training regulations."

JUNE, 1942 — Vol. 32, No. 6

THE CAPITULATION of Coregidor ends one phase of the war. Like the end of a march, however, it but marks the beginning of the next operation. So many earned tributes have been given the Philippine garrisons that our phrasing another would be a mere attempt to "gild the lily."

Artillerymen everywhere, and especially those who helped develop our doctrine and methods, are justifiably proud of the red-legs in the Islands. General MacArthur's flat statement of the artillery's performance leaves no room for any doubts.

INCREASING numbers of units are of course going overseas. Again we say, give us your APO number promptly, and the JOURNAL will reach you with minimum delay. Send us your orders for books, pamphlets, and training aids, and our Book Department will fill them promptly. Occasionally the Superintendent of Documents is temporarily out of stock on some of the more popular manuals, but we will do our best to avoid delays.

UNITS ABROAD can help those still here, too. With a scarcity of post quartermasters and the like you have been driven to new improvisations. Send in your thoughts, developments, wants, and wishes—others will be glad to have them.

NO JOURNAL articles are official unless so described, nor are they vouched for by the Field Artillery School without specific statement to that effect. For example, Lt. Col. Burns' recent "Maneuver of the Light Battalion," like all our articles, expresses the author's views only.

UNITS EVERYWHERE will benefit if they take *Army Motors*, a breezy monthly published for the Motor Transport Service by the Technical Service Division, Holabird Quartermaster Motor Base, Baltimore, Maryland. It is chock-full of practical dope for everyone concerned with motors—and that includes just about every one of us.

**The United States
Field Artillery Association**

ORGANIZED JUNE 7, 1910

President

Brigadier General George R. Allin

Vice-President

Major General Lewis B. Hershey

Executive Council

Brigadier General George R. Allin
 Brigadier General William H. Sands
 Brigadier General C. C. Haffner, Jr.
 Brigadier General Rex W. Beasley
 Colonel Alan L. Campbell
 Colonel Thomas North
 Lieut. Col. Ralph C. Bishop
 Lieut. Col. Maurice W. Daniel
 Major George L. Hart, Jr.

Secretary-Treasurer

Major John E. Coleman

	PAGE
THE COVER ILLUSTRATION: GPF ON LUZON IN DECEMBER <i>Photograph by U. S. Army Signal Corps</i>	
GENERAL MACARTHUR'S TRIBUTE	418
HOW THEY DID IT	419
<i>By Captain Edward Kraus, FA</i>	
LEADERSHIP	423
<i>By Brigadier General Vincent Meyer</i>	
THROUGH THE MILL	425
<i>By Lieutenant John Hughes, FA</i>	
CADRE TEST—I	430
THE RUSSO-GERMAN WAR: PART I	434
<i>By Colonel Conrad H. Lanza</i>	
LIEUTENANT COLONEL NYE TO FIELD DUTY	441
COOPERATION BETWEEN ARTILLERY AND INFANTRY HEAVY WEAPONS	442
<i>Translated from the German</i>	
PERIMETERS IN PARAGRAPHS	447
<i>By Colonel Conrad H. Lanza</i>	
ARTILLERY IN DEFENSE OF A COAST LINE	450
<i>By Lieutenant Colonel W. S. Nye, FA</i>	
THE FIELD ARTILLERY SONG	455
SOLUTIONS TO CADRE TESTS	456
AMMUNITION IN COMBAT	457
ROAD TO DUNKIRK: CHAPTER III	459
<i>By Henri de la Falaise</i>	
TANK ATTACK DOWN A ROAD	468
<i>By Lieutenant Colonel N. W. Jones, FA</i>	
GERMAN CASUALTIES IN RUSSIA	470
<i>By Lieutenant Andrew M. Kamarck, FA</i>	
JEEP ARTILLERY	477
<i>By Major Charles W. Raymond, 2nd, FA</i>	
THE UNEXPECTED ALWAYS HAPPENS—II	480
<i>By Lieutenant Colonel David S. Larr, GSC</i>	
SWITZERLAND SURROUNDED	484
NOT IN THE BOOK	486
DIARY OF WAR EVENTS	488
BOOK REVIEWS	490

Published monthly by the United States Field Artillery Association. Publication office 3110 Elm Avenue, Baltimore, Md. Business and editorial office, United States Field Artillery Association, 1218 Connecticut Ave., Washington, D. C. Address all communications for publication to the Washington office. Entered as second class matter August 20, 1929, at the post office at Baltimore, Md. Copyright, 1942, by The United States Field Artillery Association. Subscription price \$3.00; Canada \$4.00; foreign \$3.50; single copies to subscribers, 25 cents; nonsubscribers, 35 cents. THE FIELD ARTILLERY JOURNAL pays for original articles accepted. It is published without expense to the government. Authors alone are responsible for statements made. *Addresses, and changes of rank, will be changed as frequently as desired, upon notification; not otherwise. Changes should reach the editor three weeks before date of next issue. Immediate notice should be given of any delay in the receipt of the magazine. Unsolicited manuscripts should be accompanied by return postage.*

In many situations that seemed desperate, the artillery has been a most vital factor. On every occasion when artillery was used with audacity the Japanese were checkmated and seemed completely bewildered.

The strong effect of massing artillery fire, using a fire direction center connected with all observation posts available, has been proven beyond question. The 155 GPF have been the most effective guns; with a maximum of mobility I have used them in concentrations of large numbers. Particularly when surprised, the enemy has been highly sensitive to heavy artillery concentrations. I can make no suggestions for the improvement of the methods taught at Fort Sill.—*MacArthur, concerning his field artillery on Bataan.*





The GPF's were busy from the beginning of the campaign. This one is emplaced near Dagupan, early in December. (Signal Corps photo.)

HOW THEY DID IT

By Captain Edward Kraus, FA

In his Australian headquarters, General MacArthur recently said of the troops in Bataan, "Never has an army done so much with so little."

As already disclosed, the first defensive position in Bataan ran from the vicinity of Abucay on the Manila Bay side to Moron on the China Sea, crossing Mt. Natib in the middle of the position. On the east or Manila Bay side the mountain began its 4,000-foot rise sharply about seven miles inland from the beach. Its base covered seven to ten

Editor's note: The author served in the Philippines for three years before returning to the mainland a month before Pearl Harbor. He had the unique experience of being the artillery member of the staff which laid out the First Defensive Position at the north end of Bataan, north of the new lateral road across the peninsula. That assignment sent him on foot over the ridges and through the draws and jungles of the entire sector. That experience now gives us an accurate picture of matters formerly unknown to us, but of which our enemy now has full information.

miles of the main line of resistance, from east to west, while on its west side it sloped off into a series of parallel ridges which ran for some eight miles to the China Sea. Returning to the beaches on the east of the line, we find the ground flat for a mile and one-half from the water line. There were few trees here, but many houses were grouped together in barrios. Visibility was negligible due to the houses and the flatness of the terrain, but beginning a mile and a half from shore the ground rose into gently sloping ridges which increased in elevation for another four or five miles until they reached the base of Mt. Natib itself. These ridges were generally heavily wooded except in the vicinity of an hacienda, where the ground was partially cleared for cultivation. The infantry line ran along one of the wooded ridges, while the supporting artillery, in order to be able to shoot out of its positions, was necessarily on a cleared one. However, all positions were defiladed and many of them had overhead cover. Positions were found from the flat ground westward almost to the base of Mt. Natib itself, five miles from the beach. From the higher ground near the mountain, guns could pour a devastating enfilading fire on enemy approaches and positions to



Bataan traverses had to be done the hard way, with machetes working overtime. (Signal Corps photo.)

the north. Observation, also, was perfect from the ridges in the hacienda. It was from these positions that the artillery won its duel with the Japs early in the war.

The entire coastal strip of Bataan was covered either with rice paddies or barrios, with practically no trees for cover. Where the ground was too high or too rough to cultivate, as was the case about two miles in from shore, huge trees covered the ground so effectively that it was impossible to shoot guns from there, and more often impossible to bring guns into the woods without building a road over rice paddies and through jungle. Observation was even more at a premium than gun positions, because suitable high ground was practically non-existent except in the mountain area. If there was high ground, it was impossible to see anything from it other than more treetops below. For the same reason one could not see even from the mountains themselves. It thus becomes obvious why the infantry line was chosen within supporting distance from the cleared ridges on the hacienda grounds. Of course it was always possible to make clearings for gun positions and to build roads to them, but then enemy aviation could easily pick up such telltale signs. Some clearings, however, were made during the campaign when guns had to be emplaced and no already-cleared areas were available.

It may appear from this description that defense of Bataan was relatively simple and easy, even for a small force. As a matter of fact, due to the peculiarities of the mountain and jungle more men were required than would

"normally" have been needed for a proper defense. Several deep chasms or canyons pierced the main line of resistance where the hacienda ridges meet the base of Mt. Natib. These canyons serve as drainage for the mountain, and have been worn to a depth of 300 to 1,000 feet, with the walls almost vertical. The trees on the mountain and in the canyon bottoms average one hundred and fifty feet in height, as a conservative estimate. These stream beds, therefore, were excellent corridors of approach for entire companies at a time, and so required sizable covering forces in them. From references made to Abucay in the communiques of early April, it may be assumed that part of the American lines still ran in its general vicinity.

What type of fire did the artillery employ against the Japanese? It was the massed fires of several batteries which were shifted quickly to critical points as the need arose, data for which came from unobserved firing charts. Except for the fact that no Graphical Firing Tables were on hand, the artillery in Bataan employed the principles of the Fire Direction Center as now taught at Fort Sill. These firing charts were grid sheets built up from survey data or wide angle photos supplemented by survey, or a combination of both. As early as two years ago the Air Corps had taken wide angle photos of the entire Bataan Peninsula, and it is believed that newer photographs were taken and developed in time to be of use in the present war.

The survey on which the firing charts were based was unbelievably extensive, the important features having been completed long before the army withdrew to Bataan. The training for survey included the gun batteries, and the foundation for that training was laid over one year ago. At that time what artilleryman had ever heard of a gun battery performing a detailed survey? Moreover, who had ever heard of a gun battery undertaking a survey over a seventeen-mile front and continued for over forty miles to the rear? Such things made no difference to Colonel Louis R. Dougherty, who in a recent issue of THE FIELD ARTILLERY JOURNAL was termed a "kind of magician." However, practical considerations led up to the requirement for this survey: at that time three batteries had to cover all of Batangas Province, which stretches across southern Luzon from the beaches all the way to Manila. It was therefore believed that the batteries would be aided immeasurably if their gun positions were surveyed in, and each position area tied in to its critical targets by survey. No photographs were available, so the work was done on grid sheets. Each target and position area, besides being tied together, was tied in to bench marks or to prominent sections of the road network; this method obviated the necessity of running a continuous traverse between position areas. There were three battery commanders, and consequently three types of survey; Captain Frank Carpenter preferred his long traverses to be accurately taped, Captain Lester J. Tacy preferred to adapt fire direction instruments to a civil engineer's survey text,

and Lieutenant Thomas used a combination plane-table and stadia traverse together with long-base intersection. No transits were available, but each employed several cross checks on his work and thus held errors to an allowable minimum. While this was going on in Batangas, three other batteries were doing the same over the entire Lingayen front. A month later, all batteries went to Bataan and surveyed in all possible gun positions on the main defensive positions, including both alternate and regular positions. Since, as described above, positions were at a premium, this was not a prohibitive task. At the same time, because positions were so scarce, it was possible to locate probable enemy positions, important bridges, and exposed sections of road in the target area.

It was from charts like these, supplemented by wide angle photos or vice versa, which enabled General King to mass the fires of his batteries to break up critical threats anywhere in his front. There is no doubt but that it was these firing charts which permitted the massing of artillery fires on waves of attackers as little as 200 yards from our own foxholes. Just as massed artillery played a decisive part in many a battle for Frederick the Great, for Napoleon, for McClellan against Lee, and for the Allies in the battle of San Mihiel in 1918, just so did the principle of massing artillery fires throw the balance in MacArthur's favor.

Then why did not the artillery break up Yamashita's attack against Wainwright? Probably the larger proportion of our artillery was moved into beach positions along Manila Bay to meet the threat coming from that direction. It was impossible to fire effectively from the regular positions into the Manila Bay area because of masking trees near the gun positions and also due to the fact that there would have been too much dead space on the bay near the beaches. On the other hand, once the guns were moved to the beach positions it was impossible for them to mass fires on the main Japanese thrust on our right center. There was not enough artillery to cover both sectors. The Japanese thrust on the right center therefore probably met relatively little artillery fire in a sector where the avenue of approach was most favorable to the attacker.

To give the complete picture of how the army of Bataan did it, it is necessary to mention the state of training of the Philippine Scout and Philippine Army artillery. Two men probably most immediately responsible for this condition were Major General Edward P. King, Jr., and Colonel Louis R. Dougherty, both of them artillerymen, the one in command of Fort Stotsenburg, the other commanding its field artillery.

To a Filipino, enlistment in the Philippine Scouts of our Regular Army was an upward step in his social status—he got his clothes, he ate regularly, and he earned more money than he would as a civilian. He therefore enlisted to stay until retirement, his average period of service was 12 years, he should have been good, and he was good! But what about the Philippine Army Reservist who had an average of five months' training? On March of 1941 I observed the



The Filipinos worked well in all types of teams. (Life photo.)

drill of a field artillery battalion in the Philippine Army maneuvers. This battalion had available for training, four 2.95-inch mountain guns, two panoramic sights, one BC scope, one aiming circle, and very little other equipment. The tenth day after mobilization it put on a demonstration. Since there were no prime movers available, the guns were first put into position by hand, but no other installations were set up. At the whistle the wire section ran a line 300 yards from the guns to the OP, by hand reel. At the same time the detail set up instruments on the OP and computed initial data for observed fire on a target. Two and one-half minutes after the first whistle I saw the drop fall on the switchboard as data went through to the guns! Needless to say, in my subsequent recommendations I stated that this unit was then ready for combat provided it was led by an American officer. (These men later saw combat against the Japanese after they had been mobilized only three weeks.)

Early last year the Scouts expanded to include five more battalions of field artillery. To illustrate how rapidly they developed and how proficient they became, this example bears citing. By the following Fourth of July there did not appear to be any difference between the new and the old Scout batteries, so one of the new batteries was chosen to fire the 48-gun salute on the Fourth. That battery fired one round every five seconds, exactly on each fifth second by the stop watch, and did not have a second's variation from the total time prescribed

for the salute—and that battery had one misfire to take care of in the process!

That type of training showed up just as well in service practice. These new batteries showed the same standard of training in all practical phases of artillery: marching, driving, occupation of position, displacement, etc. Yet at this time they had only four months' service. How was this accomplished?

There was no secret about the methods: they were simply hard work and practical application. General King was responsible for the hard work and Colonel Dougherty for the practicality of the methods. Beginning with the mobilization of these recruits, half-holidays disappeared from the old tropical schedule and reveille was pushed up to 4:30 AM. First call for drill sounded at 5:50. Recall from a very intensive day of drill and training came at 4:30 PM. It is obvious how concentrated training of this nature got results, but in the writer's opinion the secret which assured continued improvement after basic training was completed was a simple order from the commanding officer that henceforth, in the morning, batteries would leave the gun park daily, would occupy position properly, displace, and otherwise continue their training, *but there was to be no*

training in the gun park in the morning! This avoided the tendency, which so often occurs at the end of a successful "thirteen week training period," of needlessly boring the troops with unnecessary repetition of parts of the same training program, thereby halting their progress. The troops got what repetition they needed to "keep their hand in" while doing something more advanced (as a group) outside the gun park. But another order was put out along with that given above: *No officers, including battery commanders, were allowed anywhere near barracks in the morning between morning drill call and recall.* A concession was later made to battery commanders so they could go back to the orderly room at 11:00 AM. Afternoons at this stage of the training were passed largely as in most camps; along with continued training there was a minimum of fatigue, and more time was allowed for administration, but only a minimum, for the officers were constantly present at drill with their troops all day long. This requirement was met even when the number of officers averaged less than two per battery for the first six months after the expansion! It is no wonder, then, that a background like this developed troops "that did so much with so little," Surely no greater tribute could be asked for.

In a military or naval sense, distance is not measured by miles. Napoleon found all the capitals of Europe closer to Paris than the sea-coasts of England. On the other hand, in the Boer War, the English discovered that the five thousand miles from Portsmouth to Cape Town were shorter than a few hundred miles from Cape Town to Pretoria.

Distance from a base in a military sense is measured by the time, ease and capacity it takes to move bodies of troops and munitions to a secondary base in the theatre of war or to armies in the field. The space lying between an army and its base, instead of being measured by miles is determined by the speed of the means of transportation, the immunity of the lines of communication from attack, and the number of lines converging from the main base to the theatre of war.

Two places a thousand miles apart, but connected by a railroad, are closer together than two places only one hundred miles apart with no other means of communication than a country road. The sea, when free from the enemy's warships, offers the best means of communication, not only on account of the speed of modern steamers and their carrying capacity, but from the fact that their lines are immutable and can be as numerous as are the ports controlled on the enemy's seaboard.

LEA, *The Valor of Ignorance.*

. . . LEADERSHIP . . .



By Brigadier General Vincent Meyer

His leadership, one of the most important things in an officer's career, largely determines his success or failure. It has been said many times that leadership is leading, not driving. That is correct within limitations. Proper leadership does the following:

(1) It sees that explanations are made thoroughly, patiently and carefully.

(2) It excuses mistakes made through ignorance or through the fact that some men are slower than others to grasp an idea.

(3) It does not excuse mistakes made through laziness, carelessness, indifference, or an obstinate unwillingness to play ball. Leadership (that is, leading) stops with such people and driving must take its place. People such as I have just described must be *forced* to do what others are doing because, if they are not forced to do what others are doing, they will ruin the record of the team.

Leadership requires a sense of loyalty from the bottom all the way up to the top; a sense of loyalty to your leaders and to the organization of which you are a part. Leadership also requires a sense of loyalty from the top all the way down to the bottom; it must begin at the highest echelon of command and continue straight down through the lower echelons. Noncommissioned officers must be loyal to the members of their platoon or squad; they must protect them

and stand up for them when they are acting honestly and in good faith; at the same time, this loyalty does not extend to the protection of them when they are acting dishonestly and in bad faith. The situation with commissioned officers is exactly the same.

Leadership requires:

(1) A sense of justice and fair play.

(2) A sense of appreciation and the ability to praise where praise is due.

(3) The courage to condemn—perhaps severely—if condemnation is merited, but condemnation must be used without sarcasm. Sarcasm is the weapon of cowards and bullies.

Leadership requires:

(1) A respect for all decent men and men who are doing their level best to do what is right.

(2) Contempt for the worthless, the lazy, and the vicious.

(3) Firmness in dealing with others where firmness is required.

(4) Speech without filthy language.

(5) A sincere—not a hypocritical—interest in the welfare of subordinates.

(6) Close contact with subordinates and a friendly attitude toward them. This must be accomplished without

familiarity. It is clear that there is no caste system in the army between officers, noncommissioned officers, and privates. There is a definite attitude of friendliness, but there can be no familiarity. Let me give an illustration: Let us say that Lieutenant Jones and Private Smith, a member of Lieutenant Jones' command, are on very familiar terms. The time comes when they find themselves in battle, perhaps in a really critical situation. Lieutenant Jones gives an order and Private Smith's reaction is, "Oh, Bill Jones is just kidding; he doesn't mean that." This illustrates the danger of too much familiarity. You see the point.

Leadership requires:

(1) Dignity on the part of the leaders but not the "stuffed shirt" type of dignity with which we are all too familiar.

(2) A sense of humor—but not the humor of a clown.

(3) The will to do yourself what you expect others under you to do.

(4) The ability to endure the same hardships; the desire to share the same triumphs.

An illuminating incident was related by a selectee who was discharged from one of our divisions last September because he was over the 28-year age limit. I met this man on a train and have no reason to disbelieve his story. He stated that his battery was late in getting supper on one of those rainy evenings so customary in Louisiana during the last maneuvers. As I remember it, he was a K.P. About ten o'clock that night, the major of his battalion came in and asked if the men of the battery had been fed. The mess sergeant told him no, that the kitchen had just gotten in and that it would be probably an hour before the men could be fed. The major replied, "Well, to hell with the men. I want

something to eat right now." I ask you whether that is the proper type of leadership?

Leadership requires firm discipline but discipline tempered with consideration and tolerance. Discipline which is based on intolerance can never succeed; there must be a certain give-and-take because there are always two sides to a question.

Leadership cannot be attained through bluff or putting on a front. The leader must know his stuff. This requires preparation on the part of instructors, and one of the greatest difficulties in training today is that too often there is insufficient preparation, or no preparation at all. In many camps you can see evidences of that every day. The War Department film on training stresses adequate preparation as one of the most important points in connection with training.

In addition to adequate preparation, there must also be application. Application means study of what you are going to teach before you try to teach it. There are very few subjects that do not require brushing up on your part before you try to talk about them to your men. Napoleon was certainly a genius but his ability was attained through tremendous application and continued study.

The final test of leadership is obtained in battle. The leader who gets spontaneous reaction of all his men to his every command has reached perfection. He has built up an unbeatable team.

To summarize this matter of leadership, I would say that leadership is the example you set others. To paraphrase the Scriptures, "Do unto others as you would have others do unto you." Whether you set a proper or improper example is your tremendous responsibility. Your subordinates will be very likely to copy you because you are their leader.

A RETIRED ARTILLERY SERGEANT

with clerical experience, who has passed a civil service clerical examination, is wanted for file clerk by

THE FIELD ARTILLERY BOARD

Fort Bragg, North Carolina

You will help both the service and an old-timer if you will spread this word. Communications should be sent directly to the Board.

THROUGH THE MILL



"Well, here we are!"

By Lieutenant John Hughes, FA

I reckon I won't forget that day.

July 5, 1940, three of us stalked uncertainly into an immaculate office and faced the colonel. We were a motley crew, in civilian clothes, and he was to make officers of us.

We walked in, stood rigidly, saluted, said "Sir, Lieutenant So-and-so reporting for duty." The colonel met us easily, smiled freely, talked interestingly, gave us some sage advice, and told us to report at his office at 1 PM. He would take us to call officially on the Commanding General. The previous summer I had seen this general in action. The army was new to me then and I failed to understand why grown men with captains' and majors' insignia on their shoulders should double time to do his slightest wish. Now I was to stand before this hard-boiled gentleman for his inspection and blessing.

Of course I had to buy and borrow to accumulate the necessary uniform. Khaki trousers and shirt, tan shoes, GI belt, single Sam Browne, campaign hat, saber with chain, and white chamois gloves. I believe that I had never worn a pair of gloves on any occasion except when pulling corn and hauling rocks, so the idea of wearing gloves (white ones!) in broad daylight and publicly was embarrassing and a little frightening.

We were there at exactly 1 o'clock; I'd always believed in being strictly punctual. During the day five others had reported in and the colonel surveyed us, all assembled. "In the army, gentlemen, 1 PM means 12:45, remember that."

We went to Post Headquarters and the general received us gracefully—that's the best word to describe it. We lined up Indian file and plodded (saber chains clanking) behind

The first of a series of the experiences, from the exasperating to the enjoyable, of a young officer who has been on active duty since his ROTC graduation two years ago. There is many a pointer, both positive and negative, in his articles.

the colonel, who properly asked permission to introduce us. Although he had been with the eight of us no more than ten minutes, he remembered our names and performed his duties faultlessly. Right there I determined to make concrete attempts to remember names. Months later I met the general again, and he still knew my name—without hesitation.

We removed the right glove, stepped up, saluted smartly, shook hands, then lined up along one wall standing carefully at attention while the general questioned us concerning our civilian professions. We had among us a couple of agriculturists, an artist, a business man, a couple of journalists, an engineer, one who hadn't decided.

"Gentlemen," he said, "the army is an hierarchy which is passed down from officer to officer.

"We want you to enjoy this year of service here. Also we want you to learn something of the army and the way we do things. Be careful of the uniform, have and demand respect for it. You are honored to wear it."

We took our saluting departure, thoroughly initiated into the hierarchy and with the general's kindly offer of "Call on me, at once, if I can assist you."

A few years ago I had an instructor (military) in

whose classes I held a very minor part and who had no particular reason for noticing me above the dozens of others in his classes. Yet four years later, several hundred miles away and in unexpected circumstances, this officer spoke to me, using my name as if we had visited the previous day. I believe he would recognize every member of his classes.

Many times in talking with older NCO's, the name of some prominent general officer would be mentioned. Often an NCO would immediately exclaim, "Why, Lieutenant, I served under him in 1916 on the Mexican border when he was a 2nd Lieutenant. I remember . . ." And they could tell minute details of ancient service, giving names of other officers in their outfits.

Whatever obscure faculty military men have that gives them such great advantage, try hard to develop a like characteristic and use it. You can not over-value its importance to you in the service.

SOCIAL MATTERS

In the army you have social and official obligations toward your superior (senior) officers. Preeminent among the social graces is that you call on your commanding officer socially as soon as practicable (first 24 hours). It was customary where I went on duty to make the social calls on Tuesday and Friday evenings between 7:30 and 9. You were to remain no longer than a quarter-hour and were to make those calls monthly or thereabout. I died the proverbial "thousand deaths," for although I had no fears of speaking before assemblies, I had built up a feeling of awe at calling on a colonel. What to do? What to talk about? You'll have no troubles at all. And by the way, a cigarette burns just a call-length, eliminating obvious watch-checking.

Now this thing of social calls should not bother most of you very much, for I know that a lot of social matters have been radically curtailed; but there may be stations to which you are assigned where you will be expected to attend to your social business.

It is customary to make the calls (as mentioned before) and to leave cards—one for each adult member of the household on which you're calling. However, if they're absent you may simply leave your cards. That constitutes a call. All calls must be returned within a few days. If you're married, the young lady must accompany you on your forays into the social realm, so you must be prepared for that. It is not difficult, she just goes along. (Simple, isn't it?) What you wear depends on too many things to include here. If you don't know or are in doubt, ask your BC what to do. It is entirely proper to do so.

Followed some weeks of learning the ropes, buying uniforms, getting acquainted, and attending classes. While the uniforms were being tailored, we wore makeshift outfits that must have brought pangs of mirth or disgust to the older Regulars.

EXPERIENCE TELLS

Right off I was impressed by the simple efficiency of the battery officers and older Non-Coms. Those officers, then 1st Lieutenants with about 10 years' service, knew all the answers. I was continually amazed at their knowledge of infinitesimal points. Any one of them was perfectly at home making camp on the range, handling battery paper work, shootin' the daylights out of a target.

My first BC was not entirely new to me. In the summer of 1939 I had watched him as his battery demonstrated over a difficult-draft course. I had watched him with awe: the straight line of his jaw, the glint in his piercing eyes, his uniform exact in every detail; heard him speak crisply; seen the highly polished crop in his hand point out the good and bad alike, wholly without emotion. Those strong eyes were unchanged when a team failed to make a difficult course and went into reverse to crumple in a heap at the bottom of a gulch. I remember that I confessed to my friends that if I should be assigned to the command of such a man, I would fear for my personal well being. But his voice held concern as he personally assisted in extricating men and horses. He examined injuries, told some man to mount up, dismounted another.

The fact is I went to him inevitably. First came orders sending me to his post; next, his battalion; then his battery, and I was there resolutely reporting for duty. In similar fashion I reported in his orderly room each week-day morning for several months, heard his crisp "good morning," got my orders for the day, saluted, and carried out the orders.

In my short service I've had five battery commanders, with not a shred of similarity in the make-up of any two.

The first I remember because I dreaded him so badly and then found that blood flowed in his veins, too; that he had his troubles and met them bravely; that he took me, the rankest of the rank Louies, and treated me like a man, set my feet on the right path, and gave me a helpful shove. He loved inspections, mounted and dismounted, and had one every week. Our first mounted inspection was a dilly. I had never seen one before, so had little idea of what to wear, do, or say. My orderly found all the required equipment, told me how to use it, tied it up for me (sympathetically, I think), and took his leave. When the battery was ready for inspection. I had to use my saber for a salute. I didn't get it back in the scabbard until about an hour later, when on the way to barracks. My horse was scared of the sun flash on the blade and wouldn't consider letting the thing back in place.

That BC never tired of lectures and critiques. Immediately following a road march, RSOP, or other similar functions, all battery officers and all chiefs of sections assembled for discussion. All participated freely with

questions and comments. It was especially valuable for the younger officers.

Too, we spent many afternoons in an adjoining sandlot with the Bishop trainers, lying on our bellies in the sand. Using field glasses we fired and discussed, fired and learned. After a few months a large angle T held no more terror for us than an axial precision. In those shoots as well as on blackboard problems, the battery NCO's, including mess sergeant, fired their problems, figuring their own data. They did good work, too. Now I fail to accept the seemingly standard practice of keeping Non-Coms far in the background.

He was a stickler for military courtesy. Many times he returned my salute before I had time to render it. He demanded that enlisted men "toe the mark" in their dealings with officers, and junior officers in their business with seniors.

I remember that one day we were walking into the barracks from the rear. A young recruit was sitting on the steps. He looked up, saw us approaching, then dropped his head and did not look again, nor did he stand as we came up the steps. The BC stopped and said a lot of things among which I remember these: "Get up. Are you in the army? Well, act like it. When an officer approaches you get up and stay that way until you're given 'rest.'" There was a lot more of it; to me, unforgettable.

I remember him too because, when he was ordered away from the battery, he cried openly and unashamed before the entire outfit.

My next battery commander was one of the most intelligent men I've run across (in or out of the service). When my old BC was crying because he had to leave, the new one was saying, "I don't have much to say. When you hear me talking, you'll know you're in trouble." With that he concluded his first speech.

A few days later he assembled the battery and made a real "statement of purpose." He made himself clearly understood, and some of the things he said were: "We'll get along all right, but you're going to do all the getting along." (That's one of the most expressive little speeches I've ever heard.)

"I don't like lying, I won't have a liar in my outfit.

"I prefer that you not get drunk, that you don't drink at all, but I don't forbid it. I do warn that you be ready and able to hit the ball when the gong sounds. Never bring whiskey or other intoxicants in or around these barracks. I'll bust any man who is caught at it, though I'm not going to snoop around trying to catch you. Don't do it.

"You can gamble whenever you like—off duty—but NCO's will not gamble with privates; men of other organizations will not gamble in this building. (If you lose your money I want it to remain in the organization.)

"If at any time you believe you are not getting a square deal, that we are jumping on you, you come talk to me.

My job is to help you and you bet your life I'll do it if I can."

He said many other things, but those summarize his intent and his actions. I learned a lot from him. One time he asked me "How do you lay a battery parallel with an aiming circle?" I very quickly and correctly quoted 161 verbatim. "That's what the book says," he agreed, "but it's not the *best* way." And he explained his system, one which many of the older officers use but which is no longer taught at Sill. Nevertheless, so long as he was BC, we junior officers laid the battery that way. It worked all right.

Of all officers I have known, I believe he knew most certainly just what to do under any circumstance. He had a particularly embarrassing (for us) little habit of sticking written exams on the bulletin board in the office. They consisted of three or four questions which were to be answered at once, without recourse to books.

"ORDERS IS ORDERS"

There came over from battalion one Monday a drill schedule for the remainder of the week. Friday morning called for cleaning leaves from the sidewalks about the battery area. Friday AM the first sergeant, very perplexed, entered the captain's office.

"The Captain wish to follow the schedule this morning?"

"Good morning, First Sergeant," (he always said "1st Sgt."), "follow the schedule."

"Has the Captain seen the schedule?"

"Follow the schedule, First Sergeant."

"Yes, sir."

The sergeant left the room grinning. He rang the buzzer, shouted "outside," and the men fell out in half-knee-deep snow. In a few minutes shovels, brooms, and brushes were throwing snow all over the place (cleaning the walks). Little matter that the snow was falling in a half-blizzard.

From his office across the parade ground the colonel (now a brigadier) saw the operations, grabbed his hat, and came tearing across to the barracks. He went at once to the captain's office and, "Look here, Captain, what's the meaning of all this?" The colonel was angry. "I want that stopped at once, then I want an explanation."

"Yes, sir."

The captain told me, "Tell the First Sergeant to give the battery a 15-minute break, then fall out for horse exercise."

As I came back into the office from my errand I heard this: "Colonel, those were your orders from battalion. Nothing reached me countermanding them. *I never question orders, sir.*"

I'll never forget the colonel's face as he apologized

profusely, "You're exactly right, Captain. You did exactly right." The colonel personally called the other batteries to countermand the order which none of them had followed anyway.

There was another thing that came about in something of the same manner. Shortly after he took command, the battalion held a "retreat formation." A short time before we were to fall out for the ceremony the BC said to me, "You will take this formation. Do you know what to do?"

I explained what we usually did at such formation. "That is not correct." He told me exactly what to do, and when the battery was formed I explained to them. We did it his way except for a mistake I made. His comment was, "Nor quite right, but a lot closer than the other batteries."



Splitting hairs: "One more on this side will about even it up!"

There were many telephone calls, consultations of official regulations, and a battalion order came out standardizing the procedure after the captain's conception of the rules.

VARIETY GIVES SPICE

Another BC who impressed me strongly came to the outfit before long. His was an entirely different approach. Talks lasted for hours, he went over the heads of his lieutenants and the section chiefs, and gave orders to anyone about anything. He was *battery* commander.

I struggled along for some months until this happened: I had organized a detail with specific assignments to each member, of course. Those duties were in accordance with the normal functioning of a battery detail and were listed in the training literature. Naturally, I had Scout Corporals 1 and 2 who were assigned to their particular tasks. As we passed through the rendezvous point on a problem one day, the BC looked around and, at random, selected a man. "When I send you back for the battery you will find

it here," he told him. "Now you watch the road so you'll know the way back here and how to lead them forward."

I was so dumbfounded that for a while I could think of no appropriate words. Finally, I found the courage to say, "Captain, I have these men organized so that each one has a particular job. Before we leave the gun-park each day I explain whatever points they do not understand. I have here Scout Corporal 1, who should go back for the battery; the man you called is a radio operator."

"Oh," he said, "you have a man for each particular job. Well, the next time you have any *new-fangled* ideas like this, let me know in *advance*."

I gave up on that one.

My BC's were men with considerable experience, conscientious, willing to assist a struggling second lieutenant whenever they could.

WHAT ABOUT THE NON-COMS?

So long as I wear the uniform, perhaps longer, I promise to remember with thanks the high-type Non-Coms who formed the nerve center of the battery.

The first sergeant actually *was* "first sergeant" in the outfit. He had spent many years in the infantry, some nine or ten of them in China. I believe I never asked him a question (and there were lots of them) that he did not answer satisfactorily.

Next in seniority was a giant of a man, the terror of recruits. From him I learned a host of practical things and some choice cuss words. Our supply sergeant (now an officer in one of our Expeditionary Forces) had been in the supply room eight or nine years. He was "over" on so many items I'm surprised the Quartermaster didn't reverse and draw from him. He was a live wire and showed me many tricks that might be considered unethical, but which nevertheless produced amazing results. From him I learned something of the several forms that concern the supply.

"Lieutenant," he told me, "there'll be a thousand times when some NCO will push a paper under your nose and say 'sign here.' Remember, there ain't no big rush about the thing. The army has been going along for a long time; it won't help things for you to rush through a lot of papers. Know what you're doing when you sign your name. In the army you're *responsible*."

"Then, too," he advised, "don't try to change things too quickly. No doubt you are full of ideas about what needs to be done to straighten the army out; but take it easy; there are lieutenant colonels on this post who are sour and grey haired because they've bucked everything for about thirty years and they haven't changed anything."

When I had any doubt about how to write a military letter I read all the military instruction on the subject, then asked the first sergeant or the supply sergeant how to do it. They never failed.

Every old-timer in the outfit was a specialist in one or more subjects. There was the horseshoer at whose word the meanest horse (except one) in the battery immediately quieted.

There was the mess sergeant who could cook anything and held the respect of every man in the battery. He had completed more than 25 years' service, and delighted in instructing recruits and firing sandlot problems. His calculations of firing data were remarkably accurate; he caught the hang of it quickly. It was a pleasure to see him struggle with a little "flank observation." Born in Switzerland, he had a noticeable accent but it did not damage the effectiveness of his words. Later in another organization I had this old soldier teaching pistol marksmanship to a group of recruits. On approaching the group I could see him brandishing a service pistol and heard him say, "*Now leesten to mee. Eef you want to learn how to shoot thee peestol, eet ees being done een thees manner.*" I went through two maneuvers with him, the first as a rank greenhorn shavetail, the second still a shavetail but his BC with a little more knowledge and a lot more experience; he "wore" well.

Often I have heard officers remark and maintain that they would prefer to make a mistake rather than condescend to asking some NCO a question which might lower that officer's exalted dignity. I know from personal observations that some individuals will bully their way through a difficult question rather than have it made easy by someone their junior. Invariably all officers at some time arrive at a point where they plainly don't know what best to do next. My counsel is that every time you can get the studied opinion and experience of a man who has been over that road many times previously, you had best hear him out, then decide when you have all the information you can obtain. My point is this: just because a man is a private and spends most of his time on KP, that does not necessarily relegate him to the sublimity of the ignorant on whose observations you may cast unthinking aspersions.

For instance, I remember a lad who spent his duty hours as a horseshoer's assistant, but who in his spare time built radios for practice and for his friends, and a television set for himself. Who was I, an officer with a single golden bar, whose only radio experience was to hear one, to refuse to ask him when I needed intelligent suggestions concerning the best use of our battery radio sets?

There was a time when I was compelled to ask assistance of an NCO. I was the battery officer representative with the battery when it was being used by a group of ORC's in a summer encampment. We had gone into the normal in-the-open position, so that when the time came to pull out, the caissons and pieces were "front and rear." They coupled and hitched that way and I could not remember a command that would face them in one direction and in column. I simply couldn't think of it, so

before the battery was reported "in order," I rode over to the second section and asked the sergeant in command.

"Why, Lieutenant," he said, "you can do it several ways. I'd do it like this." He gave me a simple command which presently I give to the battery which smoothly swung into the trail toward the stables.

As reconnaissance officer I was supposed to train a detail. Actually I didn't know enough about the practical work done in the field to make a respectable stab at it. Of course, I could make the 100%-test of the telephone, I had operated the SCR-194, and someone had shown me that there was a proper way to set up an instrument and fasten a map on a plane-table.

Again an NCO was my salvation. His many years of service had definitely answered for him most of the questions a detail man needs to answer. He had no doubts about how to run a survey, declinate the aiming circle, use the range finder. If there was wire to splice, distance to tape, or angle to measure, he could do it quicker and with greater accuracy than any man under him.

Only once in my year of service with him did I ask a question which stopped him. That was only for a moment. I wanted to know the difference in meaning in the commands, "Measure the adjusted compass," and "What is the adjusted compass?" He bit his lip for a while; then, "Lieutenant, you've got me fouled, but I'll have it in a jiffy." He pulled out the inevitable 161 and read from it aloud.

Because of my inexperience with the range finder I had little respect for the instrument. I worked many hours attempting to get the thing to give me the same reading on consecutive trials, failed, so decided I could estimate range more closely than I could obtain it by measurement. The sergeant exploded that theory by setting up the range finder, locating it by resection. Then I estimated the ranges to various points which were accurately located on the map. He used the instrument and we used the map range for the decisions. He won in so many cases that I went back to the instrument and learned to use it with reasonable accuracy.

When there was camp to make, I could feel sure that it would be done correctly. He knew exactly what his section would need and use on an overnight hike or a ten-day march. Always he had the needed article when asked for it.

Not long ago a German field marshal stated that the backbone of the German army was its well-trained Non-Coms. The same must be true of our forces. The NCO will have to bear much of the responsibility for the exact carrying out of orders.

I contend you'd better ask the man who knows, and I assure you that your experienced NCOs will have a ready, willing answer.

End of First of Series

Editor's note: The FARTC at Fort Bragg has prepared a comprehensive set of training tests which should help units check up on themselves. They were so successful at Bragg that additional ones were devised for the officers stationed there; we expect to present them in an early issue, as well as the remainder of the enlisted men's tests.

CADRE TEST—1

(For solutions, see page 456)

INSTRUMENT SERGEANTS

Part "A"

(Note: Answer any 7 questions)

Wt. No.

- 5 1. a. Name the optical fire control instruments used in the Field Artillery.
- 5 2. Define the following:
 - a. Compass (magnetic) north.
 - b. Y-north (or grid north).
 - c. Azimuth.
- 5 3. a. List the items of fire control data that can be measured with the aiming circle.
- 5 3. b. List the items that can be measured with the battery commander's telescope.
- 5 4. Describe *in detail* how an aiming circle may be declinated.
- 5 5. Describe how to measure a horizontal angle with a battery commander's telescope.
- 5 6. Describe how to measure a vertical angle with an aiming circle.
- 5 7. Name the two ways of adjusting the range finder for range.
- 5 8. List the repairs and adjustments, in general, that the battery mechanic is allowed to make to fire-control instruments in the field.
- 5 9. Explain how to orient a plane table.

Part "B"

This portion of the Instrument Sergeants' test is substantially the same as Part "C" for Operations Sergeants.

Part "C"

Wt. No.

- 5 1. Draw a diagram of the entire communications installations of your battery, name all parts, and designate all locations, in a typical tactical battery position.
- 5 2. Give a complete set of fire commands for the weapon with which your organization is

equipped, in the proper sequence, and explain each element *in detail*.

- 5 3. Give a chronological sequence of the survey plan of your battery when it goes into position, telling how you get your control from the next higher unit, and how you follow this information on down, and list the different elements you locate and explain how you locate them.
- 5 4. Give a short description of a typical OP set-up that your battery uses, telling what personnel are present, what their duties are, and what equipment they have with them.
- 5 5. Describe how to lay a battery on a given compass with an aiming circle.

Part "D"

This part consists of a series of practical problems.

Wt. No.

- 5 1. Set up the aiming circle as you would in preparation for the computation of firing data.
- 5 2. The locations of the guns and the target are pointed out, and the student is required to compute the angle of site with the aid of an aiming circle.
- 5 3. On an OP the student is given an aiming circle, and has the locations of guns and target pointed out. He is required to compute the compass for the guns to lay on the target.
- 5 4. The student has an aiming circle, and is given the locations of guns, aiming point, and target. He is required to compute the deflection command to be sent to the guns.

OPERATIONS SERGEANTS

Part "A"—Weight, 60.0

(Note: Answer any 30 questions. Put a "T" in front of a question if the statement is true. Put an "F" if false.)

1. Fire direction is the technique of maneuvering the fires of a battalion by the next higher headquarters, the battalion commander not being able to alter the request.
2. Speed and accuracy are not particularly desirable in fire direction.

3. In general, higher commanders indicate only the mass of fires, and these must be broken down into missions by artillery battalions.
4. The amount of ammunition to be expended on a given target is not dependent on whether registration has been permitted.
5. A mosaic can be used as a firing chart.
6. Angular measurements on a mosaic are relatively accurate.
7. The establishment and maintenance of signal communication between subordinate and superior units are the responsibility of the subordinate commander.
8. The establishment and maintenance of signal communication between a unit which supports another unit by fire and the other unit is the responsibility of the unit supported.
9. Radio communication cannot be readily intercepted by hostile stations.
10. A line route map is a map, map substitute, or overlay on which is shown the schematic wire set-up.
11. Firing data prepared by instruments is generally more accurate than data taken from firing charts.
12. The *target offset* is the horizontal angle between the piece and OP, vertex at the target.
13. The *base angle* is the horizontal clockwise angle from the base point to the target, vertex at the guns.
14. If base deflection has been recorded on the base point, the initial direction for a target is usually determined as a shift from base deflection.
15. An *open sheaf* is the sheaf necessary to cover 200 yard front.
16. It can generally be expected that the *firing chart* will be constructed on a 1/20,000 contoured map.
17. If the grid system is not standard, the improvised grid may be different for each unit, higher or lower, and accurate results obtained.
18. The Y-azimuth of a line may be measured at any point where this line crosses a Y-line or X-line.
19. One light field artillery battalion normally supports one infantry battalion.
20. In the division, organization for combat should include artillery in general support and artillery in direct support, plus attachments when necessary.
21. Normal artillery support of a division includes sufficient units to carry out long-range and counterbattery missions.
22. The term "groupment" is applied to a tactical command formed by temporarily placing together two or more battalions or larger tactical units assembled from different organizations.
23. *Counterbattery fire* is fire delivered for the destruction or neutralization of enemy communications systems.
24. In field artillery, reconnaissance is never completed.
25. The terms "normal zone" and "contingent zones" are no longer used by field artillery when describing zones of fire.
26. Liaison is established and maintained by the supported unit at all times during active operations.
27. Medium and heavy artillery units *do not* establish liaison with other arms.
28. The term "displacement" when applied to field artillery refers to "digging in," that is displacing so much earth. It is used in reference to camouflage pits.
29. After an attack by a persistent gas, one (1) hour is sufficient time to wait before reoccupying the position.
30. Field artillery units do not have to plan defenses against aircraft as these are performed by Coast Artillery Anti-Aircraft units.
31. It is difficult for observation planes to detect the location of CP's because of the confusion in and around them.
32. It is virtually impossible to protect a CP against a tank attack because tanks can go anywhere.
33. Light artillery should not be used to fire on tanks if another fire mission is called for.
34. In a marching column of troops, artillery units generally are located to the rear.
35. On the march, warning of approaching enemy aircraft is not necessary since everyone can see and hear them.
36. Marching artillery units do not have to concern themselves with defense against tanks, because this is taken care of by tank destroyer units.
37. Billeting parties usually precede the main body into bivouacs.
38. Bivouacs are always non-tactical, since the main reason for them is to give the troops rest.
39. The practice loading exercise for an all-rail movement which Brigade directed was a waste of time because no two troop trains are similar.
40. In landing on hostile shores from a troop ship the disembarkation of field artillery impedimenta and animals is a function of the supported unit commander and not the field artillery commander.

Part "B"

(Note: Answer any 7 questions)

Wt. No.

- 5 1. Draw a diagram of the entire communications installations of your battalion (or regiment), name all parts, and designate all locations, in a typical tactical battalion position.
- 5 2. Give a complete set of fire commands for the weapon with which your organization is equipped, in proper sequence, and explain each element in detail.
- 5 3. Give a chronological sequence for the survey plan of your battalion when it arrives at a position, telling how you get your control and how you follow this on down, and list the different

- elements the battalion locates with explanation of how they were located.
- 5 4. Give a short description of a typical fire-direction set-up that your battalion (or regiment) uses, telling the principal personnel that are present, their normal duties, and what equipment they have with them.
- 5 5. Define the following:
 - a. Compass (magnetic) north.
 - b. Y-North (or grid-north).
 - c. Azimuth.
- 5 6. List the kinds of codes and ciphers used by your battalion or regiment.
- 5 7. Draw a simplex circuit constructed with repeating coils, between two telephones, going through two switchboards.
- 5 8. List three (3) types of air photos suitable for use by field artillery units.
- 5 9. List four (4) types of scheduled artillery fires.
- 5 10. Define an observed fire chart and briefly discuss its use and limitations.

- 5 2. What is the distance from "E" to "G," along the road?
- 5 3. What is the azimuth of the line AB?
- 5 4. From "A" draw a line 1155 yards long with Y-azimuth of 325 μ .
- 5 5. Give the grid coordinates of points "A" and "B."
- 5 6. Plot a point whose grid coordinates are (88.35 - 47.55).
- 5 7. What is the elevation of points "A" and "B"?
- 5 8. What is the slope between "A" and "B," expressed in per cent and mils?
- 5 9. What is the site of "B" when measured from "A"?
- 5 10. Draw a profile of the line "F"-"G."
- 5 11. What is the minimum elevation of Battery "B" if the crest is occupied? (Compute for HE shell having lowest muzzle velocity particular to weapons in your organization.)
- 5 12. What is the distance from "A" to "B"?

BATTERY SUPPLY SERGEANT

Part "C"

(Note: Use sketch attached. Answer Question No. 1 and any 7 others. See instructor for range tables.)

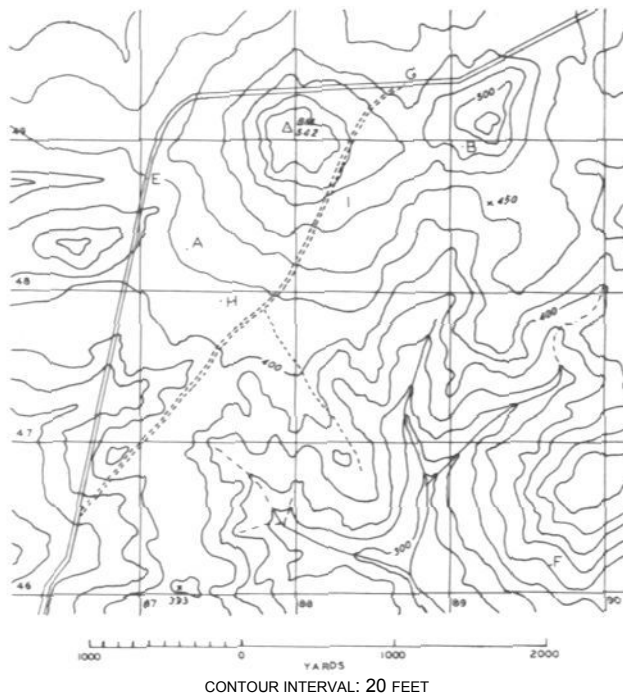

Wt. No.

- 5 1. The base piece of Battery "B" is located at (88.45 - 49.35). Prepare map data to fire on enemy automatic weapons in vicinity of (86.85 - 46.95). Use range scale for range instead of quadrant. (Shell in battery is all HE; fuze, both quick and delay.)

Situation: On July 1, 1942, you are sent as a member of a cadre to Fort Blank, N. C., to be the Supply Sergeant of Battery "C," 14th Field Artillery Battalion, commanded by Lt. Col. David S. Black (105-mm. Howitzer Bn, motorized). You report to your battery, and meet your battery commander, Captain John H. Doe. He tells you that you have a completely new outfit, organized only that day. On that day, you have only a few men assigned, who are straight in the army, most of them not having drawn any clothes. In the questions that follow, you will be given certain situations which you will have to solve on the blank forms furnished you. *All* of the information you will need to solve these questions will be contained in some part of this examination.* Fill in the blank forms as you would, correctly, all the way to completion. *In any case where typing would be necessary print in your own figures.* In *all* of the following situations you will fill in *all* of the blank forms necessary to complete the transaction and keep the necessary records in your office. Sufficient forms are furnished for all needs of the examination. In every case, state how many copies of each form you would prepare and give the disposition of each copy of each form. Pertinent data as to the cadre you went with is attached to this examination.

The following blank forms are needed for the conduct of this test:

2	copies	QMC Form No.	409
1	copy	QMC Form No.	400
1	copy	QMC Form No.	487
1	copy	WD, AGO Form No.	36
5	copies	WD, AGO Form No.	32
1	copy	WD, AGO Form No.	35
1	copy	WD, AGO Form No.	15

*Instructor should abstract T/O and T/BA.

Name	Serial No.	Grade	Spec. Rating	Class D Ded.	Class E Allot.	Date of Enl.	Place of Acceptance	Previous Enlistments
Henry J. Adams	34078658	Pfc.	3d Cl.	5.07		4/3/42	Norlina, N. C.	0
William B. Brady	789453	S/Sgt.		3.24		5/6/41	Charlotte, N. C.	1
James S. Cooper	3506582	Pvt.	5th Cl.			8/8/40	Fort Bragg, N. C.	0
John F. Dawson	694642	Sgt.			2.31	7/5/41	Fort Bragg, N. C.	1
John H. Eden	653875	Cpl.				5/2/42	Fort Bragg, N. C.	1
Henry J. Farmer	35047632	Pvt.		1.07		8/6/40	Asheville, N. C.	0
David (NMI) Frank	34047586	Pvt.	5th Cl.	7.05		10/15/41	Fort Bragg, N. C.	0
Robert S. Gray	39075482	Cpl.				3/1/41	Fort Bragg, N. C.	1
John S. Grady	32056794	Pvt.				5/6/42	New York, N. Y.	0
William R. Hollmer	34092587	Pvt.		1.57	3.05	8/6/39	Charlotte, N. C.	0
Henry S. Ingalls	785654	1st Sgt.		8.72	3.09	4/6/41	Fort Bragg, N. C.	3
Donald T. Jackson	38057429	Pvt.	4th Cl.			7/4/40	Greenville, S. C.	0
Richard W. Johnson	684537	Sgt.				8/3/41	Fort Bragg, N. C.	2
James W. Kelper	34063839	Pfc.				8/2/40	Greensboro, N. C.	1
Henry E. Long	39076595	Cpl.			2.05	11/6/39	Fort Bragg, N. C.	0
John M. Matthews	35064833	Pvt.	5th Cl.	2.56		8/3/40	Fort Bragg, N. C.	0
Thomas (NMI) Mosley	33034544	Pvt.				7/5/41	Asheville, N. C.	0
Robert D. North	39008784	Pfc.	3d Cl.			8/2/40	Fort Bragg, N. C.	0
David K. Oswald	658732	Pvt.				8/6/41	Fort Bragg, N. C.	1
Francis I. Saunders	34068599	Cpl.				5/3/42	Fort Bragg, N. C.	0

Wt. No.

- 15 1. On July 2, 1942, you requisition and draw all of the clothing necessary to outfit the 20 men assigned with a complete set of summer clothing, including toilet articles. Prepare this requisition.
- 10 2. The Battalion Supply Sergeant tells you that he is about to draw all of the Ordnance property (except ammunition and C & P materials) and that he wants you to submit a list of all of the property that you are entitled to. Prepare this requisition in the proper form as though you were going to turn it in to the USO to be consolidated and drawn.
- 15 3. On July 8, the battery commander tells you that he is expecting the entire remainder of the battery to come in during the day or the next day, and that he wants to be prepared for them. He tells you to prepare the requisition for the entire amount of cotton clothing that will be necessary to clothe the battery, less that already drawn for the men listed above. He tells you to use your judgment and draw a proportionate number of different sizes in order to fit everyone. Prepare this requisition.
- 10 4. On July 15, Captain Doe draws the following items from you for his personal use: 1 ea. pistol, automatic, cal. .45, stock No. 5-F, serial No. 458730; 1 ea. blanket, wool, OD, stock No. 3-D; 1 ea. compass, watch, stock No. 7-E; 1 ea. case, dispatch, canvas, stock No. 62-F; 1 ea. belt, pistol, stock No. 64-D; 1 ea. holster, pistol, stock No. 63-G. Fill in the necessary form(s) for his signature.
- 15 5. On July 20, Pvt. Mosley (listed above) comes in and tells you he has lost a wrist watch, value \$12.37, which was issued to him to use for recording at service practice. He did it through carelessness and is willing to pay for it. A survey is not necessary. Accomplish the necessary form (s) to account for this property.
- 10 6. Prepare the necessary form (s) to issue the clothing listed in question No. 1, above, on July 23 to the first five (5) men on the list given in the general situation. Also issue one complete set of field equipment to each man listed.
- 10 7. On July 24, Pvt. Adams reports to you and tells you he needs one raincoat, large, and that he has never been issued one. You check his records and find that he has not been issued a raincoat. Draw this raincoat and issue it to Adams and fill in the necessary forms to do this.
- 15 8. On August 1, after returning from a night march on the range (the battery had been out all night in the pouring rain) it was discovered that one pair of Binoculars, M3, value \$35.75, had been lost. The glasses had been in the custody of Pvt. Dawson, who had been hurt in an accident and had to be taken to the hospital during the night. Captain Doe decided to survey the glasses, and Captain Henry B. Jackson, the Adjutant, swears the affidavit. Accomplish the survey form completely, until after it leaves the battalion, without the action of a survey officer, since the battalion commander decides to approve it. Consider that all the action takes place in one day.



The initial attack involved forcing many bridgeheads on boundary rivers. Various means were used for crossing until bridges were completed — among them rubber boats, speed boats, and conventional assault craft. (Dever from Black Star.)

THE RUSSO-GERMAN WAR

By Colonel Conrad H. Lanza

PART I

WHAT THE WAR WAS ABOUT

Germany and Russia agreed on a non-aggression pact August 23, 1939. Germany received, so far as Russia was concerned, a free hand to wipe out Poland, and then to proceed with a war with France and Great Britain. In return, Russia received a free hand to absorb various small states adjacent to her west boundary.

The first booty of the partners was Poland. As there had not been a clear understanding as to exactly what each party was to get, a meeting occurred at Moscow at midnight September 28/29, 1939. New pacts were signed, in which it was acknowledged that Lithuania was within the German sphere, and Bessarabia the Russian.

Within two weeks Stalin occupied Estonia and Latvia. Garrisons were placed in Lithuania. He next moved against Finland; this small state refused to be absorbed and entered a war which lasted through the winter of 1939-1940, when she made peace with Russia, ceding territory but escaping

absorption. Through all these moves, Germany avoided interfering: her major mission was overthrowing the Franco-British forces in the west, and until this was accomplished no minor missions were to be allowed to divert her strength.

Late in May, 1940, Stalin began to fear that the surprising German success in France might soon make a German army available on the Russian frontier; he decided to complete his program of expansion without delay. As a precaution, Russia concentrated 22 divisions opposite East Prussia's 3 German divisions. Then, on June 15, she delivered an ultimatum to Lithuania requesting agreement to absorption into the Soviet; the Liths applied to Germany for protection. Although Stalin's actions were contrary to the midnight agreement of the preceding September, the odds of 3 to 22 were too great and Hitler refused to interfere. He considered, however, that in view of Russia's violation of the agreement, he was no longer bound by it either.

Russia next assembled troops on her southwestern frontier, and on June 22 gave Germany 24 hours' notice of her intention to absorb Bessarabia. Hitler counseled Rumania to acquiesce, but privately advised that this concession was only temporary and that at the proper time Rumania could expect to receive her territory back. Russia occupied Bessarabia.

The war in France was now over. Hitler made a revised estimate of the situation. Needed resources not then under his control could be had from Russia, but not from other places then accessible to Germany. It would be best to obtain them peaceably from Russia, and he had been attempting to do so. If Russia would not furnish them, he could not expect to win against the combined strength of the Americans and British, and in this case would have to take them by force. This meant war with Russia. It would take too long, however, to transfer troops from France to Russia to make it advisable to start a campaign this year.

Commencing early in July, 1940, over a hundred troop trains a day were moving across Bohemia from France to the Russian border. At the same time Russia reinforced her frontier. Incidents between frontier patrols occurred from time to time. Supplies from Russia became increasingly difficult to obtain. Oil had been coming in fair quantities. The transfer point from wide-gauge Russian cars to German cars of standard gauge was Minsk, where in July a Russian train of tank cars, by reason of a misplaced switch, ran into a German train. The wreck caught fire, which spread and burned all transfer facilities. The Russians expressed great regret and explained that the accident was the result of Polish sabotage. The Gestapo reported that the "accident" was purposely caused by the Russians, and that the Poles had had nothing to do with it.

As similar incidents were constantly occurring, Germany suspected that Russia was furnishing as few supplies as possible. Hitler had to have the supplies, and assurance that he could count on receiving them regularly. He determined to have a heart-to-heart talk with the Russians, so invited their Foreign Minister, M. Molotov, to come to Berlin and discuss the situation with him; the meeting occurred November 13, 1940.

Hitler was frank, explained he needed supplies, invited Russia to join the Axis. If Germany, Italy, Russia, and Japan were united, the combination would have sufficient resources and fighting power to meet the Americans and British. He thought this was a logical combination, and best for all. Molotov declined, stating that Russia wished to remain neutral and stay out of the war. It further wished Germany to agree to eventual Russian occupation of Finland, Rumania, Bulgaria, and the Straits at Istanbul. If Germany would do this, peace might continue between them indefinitely. Hitler could see in this proposition no advantages to him and many dangers. If Russia acquired

this territory, he might lose the small supplies of oil and wheat he was now getting from Rumania. Besides, if Russia should later join the Americans and British and also possessed the Balkans, a new front against Germany would be open in that direction.

He therefore declined Molotov's proposal and at once decided on war with Russia. He had to have its resources. He would not, however, start the war at once, as the season was not propitious and it would be necessary to clear out the Balkans first.

GERMAN PREPARATIONS

Germany started the Balkan war early in April, pushed it to rapid conclusion. By June 18th the Balkans were clear of hostile troops and a non-aggression treaty with Turkey was signed. Bulgaria concentrated troops on her Turkish frontier, kept them there.

Active allies had been secured for the war with Russia. Finland and Rumania, aware that Russia was awaiting an opportunity to absorb them, and anxious to regain their lost provinces, readily agreed to join and were furnished some German troops. The small Baltic states were ready to revolt, and were secretly given materiel for sabotage. Hungary was anti-Russian and obligated to Germany for substantial additions to her territory, and with Croatia and Slovakia agreed to join in the proposed war. Italy agreed to furnish 2 armored divisions and some of infantry.

The total population of all Axis states was about 175,000,000—approximately that of Russia. The Axis had to leave substantial forces in occupied countries and in north Africa, while Russia had a large army in the Far East watching Japan. Relative strengths were about equal.

Early in June Russia had rather accurate reports of the concentration of large German forces on her frontier. The United States and Great Britain were fully aware of this situation by June 11, but thought that Hitler was engaged in some new blackmailing attempt and that there would be no new war. Their diplomatic representatives advised Russia not to stand for anything of the kind, and assured her that the democracies could be counted upon for the utmost help. Russia considered herself so strong that Germany would not dream of attacking her and so waited from day to day for some German demand. None came.

THE WAR STARTS—INITIAL OPERATIONS

The Germans estimated that Russia had these forces: in Poland, north of the Pinsk Marshes, 65 divisions (including 7 cavalry and 3 armored ones), plus 12 armored brigades (counted as 6 divisions) and 2,000 planes; in Poland, south of the Pinsk Marshes, 82 divisions, including 13 of cavalry; in rear areas, in GHQ Reserve, 68½ divisions (including 13½ of cavalry), and 6 armored brigades (counted as 3 divisions); total immediately available, 215½ divisions; available later, approximately



210 territorial divisions; grand total, 425½ divisions. To these should be added non-divisional troops consisting of 100 battalions engineers, 25 regiments railroad troops, 35 regiments heavy artillery, 12,000 planes (in addition to forces in the front line), and 12,000 tanks (at least), in addition to complements in line.

German GHQ decided to make its initial main effort against the Russian north group. Of the 65 divisions in this command, approximately 49 were west of the Niemen and Szczara Rivers, apparently with a view of starting an offensive. It was planned to attack this force from the north on the line Lomza—Grodno, and from the west across the Bug River, north of Brest-Litovsk. Panzer troops would push from Suwalki Province and seize the line of the Niemen-Szczara Rivers on the east side, thereby separating the Russians from their base. The Pinsk Marshes were impracticable for large bodies of troops, and would prevent retreat to the south or the arrival of reinforcements from that direction. To prevent their coming from the east, another Panzer force from Suwalki was to proceed to the vicinity of Minsk, face east, and prevent any hostile forces from advancing from White Russia.

The Russian south group was to be attacked from Poland. Troops from Hungary and Rumania were to attack at a date to be fixed later, and cut in rear of Russian troops expected to be heavily engaged in Galicia. Troops in Finland were not to attack until after Russia had an opportunity to withdraw troops from that front to reinforce what it was believed would be a serious situation in Poland.

The initial attack was to be at 3:00 AM, 22 June, 1941, and was to be without notice or preliminary demands of any kind. It was hoped that the enemy might be caught off guard, and an opportunity thus had to destroy a large part of his air forces on the ground before they knew that war had started. The air forces were also to attack CP's immediately to interrupt the enemy's command facilities.

Germany's order of battle is at this time known only down to include armies. There is yet no reliable information as to the divisions employed. Forces (with commanders and missions) were as follows:

- a. *Arctic Detachment*, General von Falkenhorst—advance on Murmansk.
- b. *Finnish Group of Armies*, Gen. Baron von Mannerheim—attack north and south of Lake Ladoga.
- c. *North Group of Armies* (16th Army, Colonel General Busch; 18th Army, Colonel General von Kuechler; Panzer Army, Colonel General Hoepfner; Air Fleet, Colonel General Keller), Field Marshal Ritter von Leeb—advance on Leningrad from East Prussia.
- d. *Center Group of Armies* (4th Army, Colonel General Strauss; 9th Army, Field Marshal von Kluege; 14th Army, Colonel General Baron von Weichs; Panzer Army, Colonel General Hoth; Panzer Army, Colonel

General Guderian; Air Fleet, Field Marshal Kesselring), Field Marshal von Bock—attack in north Poland.

e. South Group of Armies (6th Army, General von Stuelpnagel; 17th Army, Field Marshal von Reichenau; Panzer Army, Colonel General von Kleist; Hungarian Army; Air Fleet, Colonel General Loehr), Field Marshal von Rundstedt—attack in south Poland.

f. Rumanian Group of Armies (3rd Rumanian Army; 11th Rumanian Army, Colonel General Ritter von Schobert), General Antonescu—attack east across Bessarabia.

Germany probably expected to obtain assistance from dissatisfied Ukrainians and other elements within Russia. A broadcast directed to them promised freedom of religious worship and other advantages by joining the Germans.

22 JUNE

At 3:00 AM the German armies attacked all along the border. Their air fleets bombed airdromes, CP's, and lines of communications with great intensity. Surprise was obtained. Russian planes were parked and were destroyed before they could be gotten into the air. Front line troops were thrown into confusion by the destruction of CP's and important bridges, interrupted traffic and communications, and general inability to find out what was going on. They turned out and defended themselves wherever they happened to be, without much regard to plan. The German maneuver got a good start.

The North Group of Armies, 18th Army on the right, advanced into Lithuania, right towards Kaunas and left towards Shavli.

The Center Group of Armies sent the Panzers out of Suwalki toward Minsk, while another column headed for Baranowicze. All bridges were found intact, and the advance was rapid. Infantry divisions attacked all around the Russian salient Grodno—Lomza—Brest-Litovsk. They captured Brest-Litovsk, less the citadel, and Grodno.

The loss of these places worried the Russians. The advance of the armored columns was rather expected, and was believed not to be dangerous. The Russian General Staff had studied the German campaign in Poland, noting the effects of the armored columns harassing the Polish rear areas. They had decided that the Germans would try the same thing again, and that the best counter-plan was to allow the armored columns to advance into the interior and, having protected depots and other sensitive points against sudden attack, to close in in rear of the armored invaders and cut them off from their base.

Germany's South Group of Armies attacked also, but failed to make much gain. The Rumanians made some demonstrations showing an intention of forcing a crossing of the Pruth.

23 JUNE

The Lithuanians revolted, seized Kaunas and Vilna, cut Russian lines of communications, burned depots, and generally assisted the advance of German armies. Russian forces concentrated north of Kaunas.

In north Poland the Russians made numerous counterattacks, and fairly well held their lines. The citadel of Brest-Litovsk went down, thereby enabling the enemy to secure the gateway at that place, the only one between the Russian groups north and south of the Pinsk Marshes.

Another Russian gateway was closed when Panzer divisions arrived on railroads crossing the Szczara River. All roads and railroads from north Poland east to Russia were now interrupted.

24 JUNE

German troops arrived at Kaunas and Vilna, joining up with some 60,000 insurgents. The Panzers along the Szczara sent forces east and occupied Baranowicze, opening up a line of supply to Vilna, bridges being intact.

In south Poland the Germans were stopped outside of Brody and Lwow and lost Przemyśl, which they had temporarily taken.

25 JUNE

The Panzer army reached Minsk, found strong Russian forces, but with the assistance of the Air Fleet drove them in with considerable losses. They were now in a position to protect the Panzer troops on the Szczara.

26 JUNE

Germany's North Group of Armies attacked north of Kaunas. A tank battle resulted, in which the Russians lost 200 tanks. Several Russian divisions were attacked by Germans from both north and south and were practically destroyed. Except for minor forces this battle cleared Lithuania, and insurgents took over the government. There was so little opposition that German detachments arrived this day at Dvinsk on the Dvina River. This was an advance of about 175 miles from the German frontier within 5 days.

Finland entered the war, and attacked both north of Lake Ladoga and on the Karelian Isthmus towards Leningrad.

27 JUNE

Russian troops which had escaped from the battle north of Kaunas were rounded up near Shavli.

The Russians—two armies—west of the Szczara River realized that they were surrounded. They commenced a series of strong counterattacks to enable them to withdraw eastwardly. They hoped Russian forces from Minsk would move west to their aid; however, Minsk itself was lost. Orders were promptly issued to retake Minsk to enable the troops in Poland to be rescued.

Hungary entered the war, and attacked across her rather narrow frontier.



Red infantry fords under the protection of light machine gun. (Acme photo.)

28 JUNE

Russian armored forces arrived, and about 2 divisions attacked to recapture Minsk. Russia claimed the destruction of 300 German tanks in a great battle, but did not regain the city.

South of the Pinsk Marshes the Germans had not yet made much progress. Russian armored troops arrived in this sector, and a strong counterattack was started against the German left from the vicinity of Luck.

29 JUNE

Germany completed the occupation of Lithuania, took Mitau, and entered the outskirts of Riga.

30 JUNE

The Germans advanced further in Latvia. Libau fell. It had an excellent port, and became available as a base for supplies by sea, easing the land lines.

Main German forces arrived along the Dvina River.

The Russians were definitely losing the tank battle around Minsk. German armored troops pushed on to Bobruisk on the Berezina River. The Russians in north Poland attacked incessantly, using what tanks they had and with their infantry in dense formations of 8 to 12 successive firing lines. Mowed down by machine gun and artillery fire, bombed incessantly, they refused to give in, kept on fighting.

In the south the Russians, after having first killed several hundred prisoners in the city jails, abandoned Lwow, which was promptly occupied by the Germans, Russian tank forces near Luck were driven to the east. Panzer troops by-passed retreating Russians, who were sometimes 2 and 3 columns abreast on one road. These were left to the air fleet, who harassed them by bombs and machine gun fire. Some of these Russian troops turned and attacked German infantry divisions who were following and some who were passing their flanks.

1 JULY

Russians retreating from the Luck area who were caught between German elements were rounded up and captured or destroyed, losing about 120 tanks. Troops retreating from Lwow made a counterattack with armored vehicles near Zlockzow. Further south, the Hungarians started an offensive against the Russian left.

2 JULY

The Finns made some progress in their attacks north and south of Lake Ladoga. The Center Group of German Armies, less the Panzer armies, were engaged in exterminating the large Russian force cut off and surrounded in the Bialystock area. The Russians were fighting hard, but each day saw the German lines closing in. Panzer armies had nearly overcome the Russian attempt near Minsk to rescue their troops in Poland. The Panzers spread out and occupied the area within the line

Borisov—Berezina River (south to Bobruisk, inclusive)—Slutsk. Having replenished their ammunition, they prepared to advance deep into Russia. As far as they knew there were no important Russian forces left in their front.

In the south, the Germans won the battle at Zloczow and pushed on to the line Zbaraz—Tarnopol. The Rumanians forced crossings of the Pruth River.

3 JULY

The North Group of German Armies, reorganized after the great battle north of Kaunas, resumed its advance. The 18th Army on the left, plus the Panzer Army, was ordered to advance to the line Parnu—Viljandi—Dorpat, preparatory to clearing out all of Estonia. The 16th Army on the right crossed the Dvina between Jekabpils and Dvinsk with the mission of seizing the line Pskov—Porkhov, known to be held in strength.

Panzer troops near Minsk worked backward from the circle Borisov—Bobruisk—Slutsk, rounding up scattered Russians within this region and driving them towards Minsk. The battle near Bialystock continued with undiminished vigor.

In the south the Germans reached the line Rowne—Zbaraz—Tarnopol (exclusive). The Hungarians and Rumanians were making slow progress.

4 JULY

The 16th German Army got well started on its advance from the Dvina River. With little opposition they reached the border between Latvia and Russia.

The Panzer armies finished the Russians left near Minsk, 20,000 surrendering. This cleared the line of communications through Minsk and Panzers immediately

moved out in all directions. Advised by the air force, the main Panzer force arrived at Lepel in time to attack a large force of Russian reserves who were assembled there.

All attacks on Tarnopol failed, so the South Group started a new maneuver. It was figured that Tarnopol would fall anyway, as the Hungarian and Rumanian Armies advanced further south. The Panzer forces, who had moved south from Luck toward Tarnopol, were turned around and ordered to proceed rapidly towards Novograd—Volynski, known to be fortified, with the eventual mission of advancing on Kiev. Infantry divisions followed.

The Rumanian armies were approximately halfway across Bessarabia, just outside of Balti, the capital. Their mission was to advance to the lower Dnepr. The Hungarians would connect their left with the right of the Germans moving on Kiev.

5 JULY

The Stalin Line consisted of towns, organized as strong points with modern fortifications, covering routes of approach and critical terrain features. It had been built before the war and should have been garrisoned, but was not completely so. At this date the Russians were hurrying troops into the line, the main points of which were Dvinsk, which had already fallen, apparently not garrisoned in time; Polotsk; Vitebsk; Orsha; Mogilev; Rogachev; Zhlobin, where the line going south jumped over the Pinsk Marshes to Korosten; Novograd-Volynski, which was more of an advanced post or salient; Zhitomir; Berdichev. The Stalin Line was strong, and should have presented a strong resistance to an attack. Some of the Germans arrived opposite the Line this date.

The German 16th Army reached Ostrov with its left, while its right moved to attack Polotsk, in the Stalin Line, from the rear (north). This army had a front of about 150 miles.



The Russians destroyed some bridges thoroughly, but floating ones rapidly replaced them. (Acme photo.)

The Panzer Army from the Center Group of Armies continued its battle near Lepel. Detachments reached the Dnepr, east of the Berezina River, and sought crossings between the enemy's garrisoned strong points. Quite a number of Russians were still west of the Dnepr; however, the Germans paid little attention to these, or the possibility of their interfering with supplies. The Panzers abandoned their supply line and lived off the country. Ammunition was all they needed from their own depots, and this could be forwarded largely by air. Consequently it was not particularly important whether small Russian forces were in their rear, and they wasted no time seeking minor enemy forces.

Up to now the Russians had not demolished bridges

as they retreated. This partly explains the rapidity of some of the Panzer movements. The reason for this Russian policy is not exactly known, but may have been that destruction of bridges would certainly have spelled the death knell of the very large force still fighting near Bialystock. However, the High Command now gave orders to destroy bridges whenever retreat was necessary. They appear to have given up hopes of rescuing their cut-off forces.

In the south, Panzers arrived opposite both Novograd-Volynski and Zhitomir. They attacked neither place. Russian tanks came out of Zhitomir and battle began. An American observer with these German troops reports that the Russians had not been very successful in destroying villages and towns, and that most of them fell intact into German hands. He commented also on the failure of the Russians to destroy bridges, and attributed it to lack of orders from proper authority; insufficient demolition outfits; inexperience of troops in accomplishing demolitions; and a desire of the Russians not to obstruct the roads for their own troops. He further reported that the Russians were fighting fanatically, but were poorly equipped and many had had but little training. According to the same source the crops also fell into possession of the Germans, being too green to burn.

6 JULY

The Hungarians reached the Seret River, south of Tarnopol, while the Rumanians took Cernauti. First German attempts to capture Novograd-Volynski failed.

8 JULY

The 16th German Army was engaged in a battle near Sebezh and in attacking Polotsk. The Center Group's Panzers were rounding up the last of the Russians near Lepel and other Russian forces near Borisov and Bobruisk. In general, the Germans held the line of Dnepr River north of the Pinsk Marshes, less the fortified bridge heads of the Stalin Line. The large Russian force near Bialystock was still fighting, but was obviously approaching its end.

9 JULY

The Russians' resistance near Ostrov collapsed. Near Lepel and Borisov they continued to fight but were nearly surrounded by the more mobile Panzers.

Heavy fighting developed near Novograd-Volynski. According to an observer the Russians used some 85-ton tanks mounting a single gun, calibre not stated. This kind of tank was not very successful, as it was unable to protect itself against smaller antitank weapons. A better tank was a 92-tonner mounting 5 guns, 4 machine guns, and a flame-thrower.

The Hungarians, using large numbers of cycle troops, crossed the Zbrucz River, thereby turning the Russian position at Tarnopol.

10 JULY

The last of the two Russian armies near Bialystock gave in. The Germans reported that here they captured 323,898 prisoners, 7,615 armored vehicles, 4,423 guns, 6,633 planes, and a vast quantity of other materiel in proportion. This great disaster ended the first phase of the war.

COMMENTS ON FIRST PHASE OPERATIONS

1. The Russian assumption, accepted by the democracies, that Hitler was bluffing and would not really attack Russia was responsible for the initial losses and confusion.
2. The Russians expected enemy armored columns to break through, but believed this problem could be solved by closing in behind them. This failed to work, as the armored troops lived off what they captured.
3. The German maneuver of using two armored columns had not been foreseen.
4. The German advance into the Baltic countries was facilitated by the hostility of the inhabitants to the Russians, who had not treated them very well since their forced annexation.
5. The Russians, like the Allies a year before, failed to destroy enough bridges to hinder the invaders.

HAVE YOU FIGURED

how long it would take to dig-in your battery using only the T/BA tools? *Really* dig it in, we mean—emplacements, slit trenches, ammunition pits or caves, the whole works. Well, when you have done your calculating or experimenting you'll probably have some ideas on the subject that will interest others. Type 'em out double spaced and send them to us.

Luck to You!

Lieutenant Colonel Wilbur S. Nye, who has edited the JOURNAL for nearly three years, has moved on to field duty. During his tour here he has strongly influenced the JOURNAL, which has had its face lifted, changed from a bi-monthly to a monthly publication, and nearly quadrupled in circulation. The wheel has made a full turn, though: Colonel Nye arrived simultaneously with the second edition of his history of Fort Sill and the Southwest, "Carbine and Lance"; another edition is now about to roll from the University of Oklahoma Press, the sign for a change of station.

Outward changes were not the only ones Colonel Nye has made. The JOURNAL has brightened up, moved at a faster pace, been more closely in touch with the times. Some of this would of course have occurred under any editor, as the very atmosphere of the world has changed since his advent. No small part, however, has been due to pick-and-shovel work and to the keen delight Colonel Nye has taken in his work. He goes to his new position with the truly good wishes of all with whom he has worked—the JOURNAL staff, the Executive Council, and the membership of the Association as a whole.



2nd Field Artillery Observation Battalion

On October 1, 1933, the 2nd Field Artillery Observation Battalion was formed as an inactive unit of the Army, but it was not until June, 1940, that it became active at Fort Sill, Oklahoma. With the 1st Observation Battalion as parent organization, forty-five non-commissioned officers and specialists were sent to Fort Sill to be the nucleus for the new outfit, and to this original group were added 250 men from the 1st, 18th, and 77th Field Artilleries.

The 2nd Field Artillery Observation Battalion remained at Fort Sill until the first part of February, 1942, when it was permanently moved to Camp Bowie, Texas. It is here that it continues to work on the technique of sound and flash ranging to achieve still greater proficiency.

The field of its escutcheon is Field Artillery red, bordered by gold. Superimposed on the field is a white owl, symbolic of knowledge and wisdom. In its dexter talon the owl bears a lightning flash symbolic of the flash operation, and in its sinister talon is a string trace, the upper end showing a muzzle wave and the lower end a ballistic wave symbolic of the sound operation of the Battalion. The appropriate motto, "WE FIND THEM," is emblazoned in black on a golden scroll beneath the shield.



Editor's note: Readers are reminded that the German infantry regiment has the following heavy weapons:

- 18 mortars, 81-mm. (six in the Heavy Mortar Platoon of each Battalion Machine Gun Company)
- 36 heavy machine guns (twelve in each of those companies)
- 6 light infantry 75-mm. howitzers (two in each of the three Light Platoons in the Regimental Cannon Company)
- 2 heavy infantry 150-mm. howitzers (both in the Heavy Platoon of that company)
- 12 antitank guns, 37-mm. or 50-mm. (three in each of the four platoons of the Regimental Antitank Company)

Besides its Headquarters, the German divisional artillery has:

- One light artillery regiment of three battalions, each with three batteries of four 105-mm. howitzers.
 - One medium artillery battalion of two batteries of 150-mm. howitzers, one of 105-mm. guns.
 - One artillery observation battalion of 3 batteries: survey, flash-ranging, and sound-ranging.
-

"Cooperation of weapons" is the harmonization of the attacking movement of rifle companies with the fires of infantry heavy weapons and of artillery. Infantry employs the tactics of movement, and artillery those of fire. Fire and movement are linked together by an oral or a written plan of fire.

The plan of fire includes the infantry combat missions, the observation zones, zones of action, target designations for artillery and infantry heavy weapons, and information concerning the time element, ammunition, and the artillery combat missions.

The plan of fire is completely dependent on reconnaissance. It is incumbent upon all artillery and infantry commanders to exchange with one another the results of their reconnaissances, observation, and scouting insofar as this may further the cooperation of their respective commands. However, accurate knowledge of the enemy comes only during combat.

The fundamental requirement for the establishment of a plan of fire is that each party to this contract know the characteristics and the language of the arm with which he is cooperating. Otherwise, many misunderstandings are sure to arise, much time will be lost, and "plan of fire" will be only an empty phrase.

EMPLOYMENT OF INFANTRY HEAVY WEAPONS

General

The most important requisite for effective fire is cooperation among the infantry heavy weapons. A

COOPERATION

By Colonel Kruse, in

combination of flat-trajectory and high-angle fire gives the strongest fire effect. The flat-trajectory weapons strike the exposed enemy, and the high-angle ones are used against those hostile troops that are in or behind shelters. During an attack part of the heavy weapons protect the advancing rifle companies; the rest follow close behind, always ready to take part. One portion helps the other forward, thus fire and movement are linked together.

In dividing the terrain into observation and action zones, individual weapons should supplement one another according to their type (flat or curved trajectory, type of projectile, etc.) after giving due consideration to terrain formations and cover. An effort should also be made to concentrate the fire: concentrations produce the strongest effect and should be directed just ahead of the attacking elements at the place of penetration. Whether a target should be assigned to infantry heavy weapons or to artillery depends on the type of the target, the relative efficiency of the available weapons, and the conclusions concerning the terrain.

Specific

Due to its ability to deliver continuous fire, the *heavy machine gun* is the strongest infantry flat-trajectory weapon. It is effective against low, unprotected targets up to 1,500 yards, and against plainly visible targets up to 2,500 yards.

The *heavy mortar* is effective against combat targets and nests of resistance which cannot be reached by other infantry weapons or by artillery because of technical difficulties in firing or lack of time. Whenever possible, mortar ammunition should be saved until the artillery fires have moved forward. The heavy mortar is most effective at ranges between 400 and 1,200 yards.

The *light infantry cannon (howitzer)* is normally employed against individual targets (point targets) within the zone of the hostile infantry—either exposed, under cover, or with hastily prepared overhead cover. These should be targets that cannot be reached by flat-trajectory machine-gun fire, which are beyond the effective range of the mortar, and which are too dispersed to be allotted to the artillery. The light infantry cannon is most effective at ranges from 200 to 2,500 yards.

The *heavy infantry cannon (howitzer)* is employed against targets which offer especially stubborn resistance. The fragmentation effect of its shells is similar to that of 150-mm. projectiles; the explosive and smoke effects are greater. The ammunition supply is usually limited. The most effective range is about 3,500 yards.

With antitank projectiles, the *antitank cannon* is effective

ARTILLERY AND INFANTRY HEAVY WEAPONS

Artilleristische Rundschau, August, 1941

against armored vehicles of all kinds, and with high-explosive shell, against unarmored targets, such as machine guns in the open, OP's on buildings, and the usual street-fighting targets. These guns are usually employed in platoons, and have a maximum effective range of 1,000 yards.

DIVISION ARTILLERY WEAPONS AND TARGETS

The *light field howitzer* is usually employed against targets beyond the range of infantry weapons. It may be used against:

(1) Targets within the range of those infantry weapons in case their ammunition, numbers, penetration ability, or observation are inadequate for combat.

(2) Infantry, especially when they have evaded the effects of machine guns by dropping to the ground, digging in, or taking cover.

(3) Targets not definitely located, as is frequently the case with machine gun nests, OP's, high-angle weapons behind cover, or troop concentrations in positions of readiness.

(4) Hostile artillery and tanks.

The *heavy field howitzer* is employed against similar targets, except those not definitely located ((3), above), against targets beyond the range of the light field howitzer, and against those with overhead cover which the lighter weapon can not penetrate.

TYPES OF ARTILLERY FIRE

Harassing fire is directed chiefly against such targets as routes of approach, entrenchments (especially at night), and troop shelters. It should be placed on crossroads only when detours are difficult. It should be irregular; intensive fire should alternate with single rounds. Orders should specify the amount of ammunition to be used on each mission.

Barrage fire is delivered by light (and in exceptional



Prior to the attack on France in 1940, the German artillery was given intensive training in open warfare methods. Here we see the 150-mm. howitzer, a long-barreled weapon which is almost a gun. It has a range of about 18,000 yards, is broken down into two loads for horse transport, or in one load motorized. Divisional artillery contains a medium battalion which has two batteries of this weapon and one battery of 105-mm. guns. The latter weapon is mounted interchangeably on the same carriage with the 150-mm. howitzer. (Acme photo.)

cases also heavy) artillery, in cooperation with the infantry and its heavy weapons, in a prepared defense against an attack. Such fire protection is limited in both area and time. It is ordered by higher headquarters in accordance with agreements between infantry regimental commanders and the commanders of their supporting artillery. Light signals used in connection with this fire are specified by higher headquarters, and are given by platoon or higher commanders.

Areas to be protected by artillery barrages should be minimized by delivering such fire only on areas where protection can not be effected by heavy machine guns, mortars, and light infantry cannon, and which can not be easily avoided by the enemy.

Barrages are delivered in two-minute waves. Ammunition: one light field howitzer battery, 48 rounds; one heavy field howitzer battery, 32 rounds. Projectiles from light field howitzers should not fall closer to the friendly front line or its protective barriers than 100 yards; from heavy field howitzers, 200 yards. Breadth of area neutralized per battery: light field howitzer, 100-150 yards; heavy field howitzer, 150 yards. Preparation of fire should be based on use of a full charge, and when possible should be checked by firing one gun.

For prompt and accurate delivery of barrage fire, the following are requisites:

- (1) Have constant communications between the proper OP's and the gun positions.
- (2) Have alarm equipment at the guns, and designate specific personnel for alarm duty.
- (3) Have guns set at "center traverse."
- (4) Have entries on the barrage fire chart kept up-to-the-minute by the calculator (Our recorder.—Ed.) at the gun position.
- (5) Have ammunition available of the same type and lot as was used on the proof shots.
- (6) Give the alarm at the first sign of enemy activity.
- (7) Insure the rapid illumination of aiming stakes.

During a hostile attack, fires based on actual combat requirements should be substituted for barrage fires as soon as possible.

Destruction fire is characterized by its effective destruction of the target, based on accurate ranging. It requires good observation and a large amount of ammunition. The minimum allotment of ammunition for attacking a hostile battery is 240 rounds for the light field howitzer and 160 rounds for the heavy field howitzer.

Annihilation fire is used to destroy hostile assembly positions and hostile preparations for attack or defense. It should be a concentration of as many batteries as possible, opening simultaneously and firing as rapidly as possible for a designated period. For surprise effect, ranging should be avoided. The following ammunition should be used for every surprise fire (when possible, one minute duration), including those against an enemy battery:

- 72 rounds by each light field howitzer battery,
- 60 rounds by each 105-mm. cannon battery,
- 48 rounds by each heavy field howitzer battery.

Neutralizing fires force the enemy into shelters and make it temporarily impossible for him to serve his weapons. The amount of ammunition expended must be that which is ordered when the target area is visible from the OP but the targets themselves are not definitely discernible or are behind cover. When the targets are visible, the battery commanders may decide the expenditure. Against a hostile battery, ammunition is expended according to order but light field howitzers should use at least 120 rounds and heavy field howitzers, 80.

Silencing fires are used to annihilate the enemy and destroy his weapons. Ammunition is handled as with neutralizing fires. The artillery neutralizes such targets as infantry movements, machine gun nests, occupied crests, edges of woods, hedges, and villages, and OP's. It overwhelms point targets such as single infantry heavy weapons and overhead covers, insofar as they are definitely recognizable and can not evade fire. Due to the lack of observation and ammunition, hostile batteries can usually only be neutralized, not silenced completely.

DESIGNATION OF CONCENTRATIONS

Regiments, battalions, and batteries name terrain features. Prominent points which are visible from their respective OP's are given such descriptive names as Little Round Top, Oak Ridge, or Pine Woods.

Target numbers are given by:

Regiments (1) to single, well distributed points deep within the enemy's position, which can be located on the map; (2) to enemy batteries which are to be fired upon by regimental command.

Battalions to points visible from OP's but which are not suitable for naming (such as corners of woods, and the like).

Batteries (1) to points similar to those numbered by battalions; (2) to targets fired upon by them (target numbers 150 to 199 are reserved for targets observed from forward OP's and which have not been numbered by higher authority).

Generally, areas which are to receive concentrations are given the names of flowers, metals, etc. This is especially helpful if batteries from neighboring divisions assist with the fire; if numbers were used confusion could easily arise, as numbers 300 to 399 are at the disposal of both artillery regimental commanders.

Barrage areas are designated as *right*, *left*, *center*, or *entire front*.

It is essential to inform the infantry of the terrain-feature names and the names of fire concentrations, in order that they may receive proper fire support without confusion. Target numbers should be used only within a given arm, as confusion easily occurs in spite of using prefixes. Units normally cooperating, such as the artillery

battalion with an infantry regiment, use the same target numbers under present regulations.

INFANTRY REQUESTS FOR ARTILLERY FIRE

In requesting artillery support, the infantry commander should state where, when, how long, and how heavy he desires it. (Editor's note: He should also indicate the nature of the target.) If time intervals are used to describe "when" and "how long," they must be carefully and clearly expressed as referring definitely to intervals before or during the fire. As to "how heavy," a distinction should be made between continuous fire of equal intensity throughout, fire with increasing intensity, and an annihilating fire.

The responsible tactical commander should decide, according to the situation, whether or not a request will be granted. Even though fire is withheld, the infantry and artillery commanders should confer early and frequently on their plan of fire. As an infantryman often can not know whether a neutralizing or silencing fire is possible from an artillery viewpoint, it is advisable to express the mission as "to neutralize" or "to silence," rather than to demand such fires.

It is not enough to say "The artillery battalion will assist the attack," or "The artillery battalion will cover the preparations for the attack." This is understood. The artillery mission should contain details as to what targets should be attacked and how the fire support should be given. It is taken for granted that a reconnaissance and an estimate of the situation by the commander requesting fire support has preceded the issuance of the fire mission.

EXAMPLES OF REQUESTS FOR ARTILLERY FIRE

Supporting Artillery

Example A. "The battalion is requested to protect the occupation of the regimental assembly positions by neutralizing the hostile observation post and heavy weapons on Hill 120, and by silencing any flanking fire which might come from the western edge of village A."

Example B. "The battalion is requested to support the attack of the regiment, according to the following plan of fire:

"Beginning at the hour the artillery is ready to fire until Y o'clock: preparing ranging fire and silencing targets north of stream C, in front of the 1st Battalion.

"After Y o'clock, prevent hostile observation from the wooded area 400 meters northwest of the 2d Battalion . . . by means of high explosives, and by increasing the intensity of the fire for six minutes against the targets in front of the 1st Battalion. Afterwards, neutralize these same target areas with normal fire.

"The fire on the targets in front of the 1st Battalion and in the wooded area in front of the 2d Battalion should cease as soon as their leading elements are endangered by the impacts.



The 150-mm. heavy infantry howitzer (S Inf G 33) is replacing the old 170-mm. trench mortar in all except possibly the Landwehr units. Its weight of 3,300 pounds in action permits considerable manhandling. The box trail allows a 6° traverse and an elevation of some 80°. Rate of fire is around four rounds per minute. Five charges are available, and two projectiles. The 80-pound shell has a range of 6,000 yards, but the 31.8-pound one reaches twice as far. (Acme photo.)

"The fire should then be advanced to any targets discovered farther to the hostile rear in the zone of action of the 1st Battalion."

Example C. "The battalion is requested to assist the regiment according to the following plan of fire:

"From H-90 to H-54: draw out hostile fire by means of patrols and by firing upon visible heavy weapons; preparatory fire in the regimental zone of action; supplementary preparations of plan of fire.

"From H-44 to H-1 is reserved for infantry light weapons and heavy machine guns (deception of the enemy), unless the enemy attacks.



The 75-mm. howitzer (LMW 18) is used as an accompanying weapon by both infantry and cavalry. Although normally drawn by horses or towed by motor, it can be broken into six loads for carrying on packs. Very light in weight, it can be readily manhandled. The box trail permits a 12° traverse. The 14¼-pound shell has an effective radius of 20 yards and a maximum range of 3,900 yards. The rate of fire is very high—15 to 20 rounds per minute.

"From H to H+3, annihilation fire. The draw 200 meters to the east (suspected location of hostile reserves and command posts) is allotted to the battalion as a target area.

"Starting at H+4, two batteries of the battalion will protect the advance of the 1st Battalion from hostile fire from Hill 108, and later from the edge of the woods 1,500 meters to the north; one battery will prevent enemy action from Farm D. Fire on Farm D will cease on green light signal."

Attached Artillery

Example D. "The battalion will take position so it can fire effectively in front of the entire regimental zone of action and if necessary place observed fire as near as 400 meters in front of the hostile main line of resistance. Special preparations are to be made for fire concentration on . . . Fire will be opened only on call."

Example E. "The battalion will take position so that from X o'clock on it can assist the attack of the regiment by observed fire directed at the western edge of village A and the section of woods between Hill 75 and the highway running toward D. The infantry heavy guns of the regiment are attached to the artillery. The commander of the infantry heavy guns will report to the artillery battalion command post. Fire plan follows. Fire at will."

General

Instead of the expressions "surprise fire attack" (an infantry term) or "burst of fire" (each burst lasts only a fraction of a second), it is better to use "annihilation fire" or "fire increase." Annihilation fire is released with the greatest intensity and therefore should be used only for as short a time as possible; without ranging (adjusting), this type of fire is possible only when a large-scale map is available, together with accurate weather information and sufficient time. In case of fire increase, the ordered amount of ammunition should be expended; this will depend on the nature and resistance of the target, state of ammunition supply, and the duration and rapidity of fire.

Some areas held under fire by the artillery (hedges, edges of woods, crests) can be covered simultaneously by heavy machine gun fire. The use of the other infantry weapons on such areas at the same time is usually a waste of time, as it is very difficult to distinguish between their bursts and those of the artillery.

The infantry should take advantage of the preparatory fire of their own heavy weapons and of the artillery to approach as close as possible to the enemy. The employment of concentrated fire should be a signal for every man in the assaulting rifle companies to jump up. It is the signal, "Dash forward!" And when meeting hostile resistance, it is important that the infantry not only call for artillery support, but also make full use of all of its own weapons.

* * * * *

EDITOR'S COMMENTS

The Germans emphasize that cooperation between commanders is founded on the mutual exchange of pertinent information. To save time, avoid confusion and misunderstandings, and increase effectiveness, infantry and artillery commanders should know the characteristics, capabilities, limitations, and language of both arms. This principle is of course equally applicable to cavalry, armored force, or air-borne units.

The Germans utilize our doctrine of mutually-reinforcing infantry and artillery fires, concentrating on critical areas, and taking maximum advantage of the peculiar characteristics of each weapon.

The sample requests for artillery fire indicate that besides where, when, how long, and how heavy the fire is desired, the artilleryman should also be informed "what" effect is desired and "why" it is wanted. This information greatly helps him determine the "how."

Flexibility is a prime characteristic of the German organization. In Example 5, the artillery battalion is attached to an infantry regiment, and in turn has attached to it the infantry regimental howitzers! The stereotyped solution is no solution—the mind must remain open and agile.

OLD SOUR PUSS

One of the greatest joys of living in civilization is your privilege to be of good cheer and extend courtesies to your fellow man.

From Stockholm under date of April 16, the United Press reports that Germany has decreed a "politeness Month for May" during which competitions in politeness and good humor will be held throughout their miserable land—a campaign to curb excessive manifestations of their brute propensities.

No edict or fairy wishing-ring, however, is now going to help those unfortunate people who have been reared under the slave driver's whip and those grim weapons of disease and poverty. The first and only step is to help their fellow man gain the right to be his own master. Then poverty and circumstance will no longer hold power, and the lowest creature in the land can win a place side by side with the highest.

COL. WILLIAM N. DAY, FA



PERIMETERS in PARAGRAPHS



By Colonel Conrad H. Lanza

FAR EAST (LESS THE PHILIPPINES)

The Japanese spent April consolidating their position in the Netherlands Indies. Sumatra was completely occupied. Dutch sources report continued resistance by isolated detachments in Timor and Java, but for practical purposes it must be assumed that Japan has now started her preparations for meeting a possible counterattack.

In Burma, the only active land front in the Far East, a slow Japanese advance north from the coast toward Mandalay has been in progress. Mandalay itself was savagely bombed and nearly destroyed, with large loss of civilian lives, on April 4th. At the end of April part of the Burma oil field was in Japanese possession, and the remaining wells were so close to the front as to make it improbable that they could be counted upon any longer for United Nations' use.

British and Chinese troops are opposing the Japanese, who are estimated as having from three to five divisions in Burma. Due to the jungle the British have found it advisable to remount their mechanized troops on bullock carts. Both British and Chinese have lost access to the depots in India, except for minor articles which can be brought across high mountains over unimproved trails. A further disadvantage is that the natives are anti-British and detest the Chinese, and are furnishing a wholly unexpected assistance to the Japanese.

On March 27th, Tokyo announced that the Japanese hold on the Andaman Islands and on Rangoon, as sea bases, was being extended. These may now be considered outposts for the fortress of Singapore.

On April 5th, Japanese planes attacked the great commercial port of Colombo on Ceylon, while their fleet—composition unknown—raided widely in the Bay of Bengal. The Japs claim 21 ships (140,000 tons) were sunk, and another 23 ships (102,000 tons) were damaged. At the same time other planes attacked the naval base at

Vizagapatam and Cocanada, both on the mainland of India. British reports state that in all cases damage to shore establishments was negligible, Japanese that it was considerable. About 350 miles south of Ceylon, the Japanese sank two British 10,000-ton cruisers. In all these operations the British claim the Japanese lost 25 planes certainly destroyed, while the Japanese acknowledge the loss of only seven planes. The British report their own air losses as slight, while the Japanese claim that at least 57 British planes were shot down or destroyed on the ground.

Extending their raid in the Bay of Bengal, the Japanese on April 9th bombed the main naval base at Trincomalee, Ceylon. There is no information as to what damage was inflicted on the base, but the British air-carrier *Hermes* and at least one destroyer were sunk at sea. With the previous loss of the two cruisers, the British admitted that sea control in this part of the world had passed temporarily to the enemy.

On April 10th, India rejected a British proposal to cooperate in the war by accepting immediate independence as a British Dominion, subject to the reservation that during the present war defense matters remain under British control. The full consequences of this action have not yet appeared.

On April 6th, the Japanese Premier Hideki Tojo in a speech stated "our objective in India is to smash the British interests there." He gave no indications as to any date or method of attack. A similar earlier threat had been made regarding Australia and New Zealand, with the suggestion that they abandon the cause of the United Nations and arrange for a separate peace.

On April 18th, about ten U. S. Army planes raided Tokyo, and Kobe and Nagoya were bombed by one or two planes each.

THE FAR EAST SITUATION AS TO OIL

A main Japanese mission in seizing territory in southeast Asia has been to secure oil, little of which is produced in Japan or adjacent territory.

In 1940, latest complete year for which statistics are available, Japan had a refinery capacity of 70,000 barrels per day. This may have since been increased.

The first oil areas taken by Japan were British Borneo, producing 170,000 barrels per day, and then Tarakan, in Dutch Borneo, normally producing about the same. Both British and Dutch reported at the time that all wells had been destroyed prior to capture. The Japanese reported production as reestablished in part early in January, stating that not all wells were destroyed. They may have drilled new wells, which with modern equipment can be done in about thirty days. As the Borneo field is the closest to Japan, best removed from possibilities of bombing, and as some of the oil can be used for fuel without refining, this field will probably be exploited to a maximum.

The main Dutch oil fields lie mostly in Sumatra, with lesser ones in Java. These produce about 150,000 barrels per day, and could refine it. Both wells and refineries were supposed to have been completely destroyed before Japanese occupation. Japanese reports are that some of the wells escaped destruction, but no claims are made as to the refineries. Assuming that the destroyed refineries had no salvage value, it would take about a year to build a new refinery if material and labor are available. Japan may not want to build a refinery in Sumatra, which might be close to a fighting front. A traveler who had been in both the East Indies and Japan in 1941 states he had been shown the Dutch preparations for destruction of their oil industries, and had later been informed in Japan that such destruction was foreseen and had been provided for by arranging for the drilling of new wells and the erection of new refineries. Although wells must be drilled at the field, refineries may be anywhere. New refineries might well be in Japan.

Burma has a small oil field, producing about 21,000 barrels per day. This is probably not needed by Japan, but might be useful locally. The principal reason for fighting for its occupation is to prevent its products from going to China over the Burma road. This field is the principal source of oil for the Chinese, and if it is lost, and at date of writing it seems to have been lost, there will be little other oil available for Chinese motor and aviation purposes. It may result in material curtailment of military operations in China.

In all, from the viewpoint of Japan, they have sufficient oil in sight for both war and industrial uses. Now as to the Allied position.

Heretofore, the United Nations could obtain oil in the Southwest Pacific from the Netherlands Indies, which source is now gone. The next nearest source is the Near East. Most of the oil originates in Iraq—about 225,000 barrels per day. This is a reasonably good quantity, but the pipe lines from Iraq run west into the Mediterranean Sea and not south towards the Persian Gulf. At this date the eastern Mediterranean is a No Man's Sea, and shipment of oil from the ports of Haifa and Tripoli a risky and uncertain business. Egypt is producing about 18,000 barrels a day, but is using all of it for local military and shipping requirements.

The Persian Gulf area is producing about 25,000 barrels per day. There is a large and growing military force based on the Persian Gulf in Iran, and in India, which desires this oil.

For the Southwest Pacific there remain California and the Caribbean area, which can furnish all the oil needed provided transportation can be found. The problem of getting sufficient tankers to make the voyage of 7,000 to 8,000 miles one way, depending on exact destination, is serious. This is bound to affect the United Nations' plan for a counterattack in this area, for sizable naval, air, and ground forces will all need very large amounts of oil.

THE NEAR EAST

No major ground activity occurred in Libya during April. British and Axis forces have been renewing their strength and bringing up supplies, while their respective air forces have been doing their best to hamper this process by raiding lines of supply on sea and land. The British supply line to Egypt goes around Africa, and is roughly twenty times as long as the Axis line across the Mediterranean, and consequently requires twenty times as much shipping and time.

The Axis main body is west of the line Tmimi-Mekili; the main British force is east of the line extending south from El Gazala, on a good position for defense or as a

line of departure for another offensive. Either line could be turned by envelopment from the south. Ground and air patrols are relied on to prevent such a movement from starting without detection.

The Axis has maintained continuously, day and night less one day, violent bombing of Malta, centering particularly about the harbor and airdromes. Notwithstanding, Malta is functioning as a British fortress and as a base for naval and air activities. It would be wrong to deny that the fortress has suffered from the air attacks—it has, but it carries on.

The mission of the attack on Malta may be to neutralize

that post, to safeguard convoys from Italy to North Africa. From this point of view it has had some success, for Axis convoys are getting through, subject to occasional important losses. These convoys carry supplies, for personnel can go by air. Latest information from unofficial but reliable British sources is that the Axis has transported sufficient armored materiel to strongly re-equip their Libya forces.

The mission of this force is to capture Egypt and the Suez Canal. After nearly two years the Axis has made no advance in this direction, but its army is yet in the field and a potential danger. Should the Axis ever capture the Suez Canal and the Japanese occupy Ceylon, but a single

obstacle would remain between the Japanese in the Far East and their allies in the Mediterranean. This would be Aden, whose strategical importance is now of first order. The United Nations are alive to this danger and are strengthening their forces in the Near and Middle East.

British forces in the Near East were depleted by the return to the Southwest Pacific of the valiant Anzac divisions which had fought so well in recent campaigns. They are being replaced by Poles, brought down from Russia via the Caucasus route. These are being equipped with British and American supplies, and are to form a complete Corps.

FRANCE

France is not a theater of war, but it is a factor in the strategical situation. Following protracted discussions, M. Pierre Laval was on April 14th appointed Premier, with rather plenary powers over Foreign and Internal Relations. He also personally controls the Information Ministry, which through its control of the press, propaganda, and radio, exercises a powerful influence over public opinion at home. Laval does not have command of the Army, Navy, or Air Forces, over which Admiral Darlan has been appointed C-in-C. Laval is pro-Axis, and has been for a long time. He announced on April 20th that he intended to

collaborate with the Axis, without, however, intimating that France would join in the war. Darlan is anti-British but not pro-Axis, and has consistently opposed allowing the French fleet, yet of respectable size, to fall into German hands.

German sources stress the point that Laval will reorganize the social structure of his country. No details were given, but it seems to be understood that this means suppression of the Communist party in France, which is large, is friendly to Russia and the United Nations, and has engaged in sabotage against the invaders.

The soul of the soldier can only be developed by discipline, by honor and martial deeds. It cannot be constructed to order or dressed up with false shoulders in twenty-four days by uniforming a civilian volunteer or by commissioning and spurring him with purchased valor or the transient glory of loud-mouthed multitudes. The creation of this martial soul necessitates year after year of sternest labor and toil that callouses the weakness inherent in man and wrings sweat from his heart. It is moulded by Regulusian discipline, and lives are thrown carelessly away, mechanically, almost irrationally. In the lessons of these years they learn that in warfare a relentless absorption of individuality must supervene, an annihilation of all personality. Only then can they reach that pinnacle of human greatness, to seek glory in death.

LEA, *The Valor of Ignorance*.

ARTILLERY IN DEFENSE OF A COAST LINE

By Lieutenant Colonel W. S. Nye, FA

NOTE: *The following article is a general discussion of tactics and technique. It does not necessarily represent official views or doctrine. It does not presuppose nor refer to any military plans or operations currently in progress or projected.*

Two articles¹ have appeared in this magazine discussing artillery support of landing operations. It is worthwhile also to give some thought to the defense against landing attempts. The government has announced that U. S. troops are in Ireland, Iceland, Alaska, Puerto Rico, Aruba, Trinidad, Hawaii, and other places where any fighting that occurs must, by the very nature of the situation, be in defense of a coast line. Artillery technique and tactics for such combat have been taught during past years in our Field Artillery School, as they have in service schools all over the world; methods are standard and are reasonably familiar to most of our older officers. Knowledge of such special operations must of necessity, however, be somewhat sketchy so far as our newer officers are concerned, and the present short courses at the service schools can do little more than touch on such topics. Consequently it seems appropriate to review some of the principles here, insofar as it can be done without violating secrecy requirements.

PRINCIPLES

The principles applying to artillery employment in defense of a coast line have been well stated in a text formerly used at a service school. We shall quote excerpts verbatim, as they doubtless still apply in general and must be modified only to meet the changes incident to the latest weapons and to specific theaters of operations:

The defense of a coast line parallels very closely the defense of a river line, since the main body of the defender is concentrated well back from the water's edge with covering detachments at probable points of landing.

The defense of a coast line requires carefully coordinated plans for joint action by the Army and the Navy.

In major operations, an overseas expedition endeavors to secure a port to maintain overseas communications as soon as possible. In view of the difficulties incident to a direct attack by naval forces on harbor defenses, the initial handling of an overseas expedition normally is on an open coast. After establishment of a force on land, subsequent action looking to the capture of a port and its defenses will consist mainly of land operations.

The forces employed to prevent the approach of the coast line are the navy, the aviation, and the long-range artillery of the harbor defenses. The mobile troops, supplemented by the forces mentioned, are employed to oppose the landing operations proper.

For defense by the mobile forces, the coast line is divided into coast-defense subsectors which may be subdivided into

defensive areas. In each defensive area, strong defensive positions are organized at probable points of landing, and at other points the beach line is held lightly or merely observed. The bulk of the troops in each subsector is held in reserve prepared to move on threatened points. The general reserve comprises the greater portion of the mobile forces, and, based on information of the enemy's movements, is so disposed that it may be engaged promptly when the location and direction of the enemy's main effort are known.

The initial resistance to a hostile landing is made at the water's edge. Individual light guns or howitzers are emplaced close to the beach to fire on enemy small boats approaching the shore and on elements of the enemy which succeed in landing. The fire of these pieces is coordinated with the fire of the infantry weapons for defense of the beach strong-points. Normally, direct laying is employed.

Artillery with the general reserve is held in readiness and is employed as in the defense of a river line. When time permits the emplacing of batteries prior to the disembarkation of the enemy, the water over which the small boats must approach, and the shore itself, may be subdivided into rectangular areas, each given a numerical designation, to facilitate fire direction. The use of searchlights and visual signals, such as flares and rockets, is of importance in securing efficient artillery fires during night operations. A coordinated plan of signal communication for the Army and the Navy is essential.

Railway and heavy artillery are employed to keep the enemy ships, particularly transports, at a distance from the beach. Owing to the relatively long time needed for the emplacement of these types of artillery, they are advanced into position as soon as definite information is obtained as to the enemy's intentions. Medium and light artillery are employed to fire on enemy transports and small boats as well as on enemy forces effecting a landing.

In anticipation of the landing, preparations are made for ammunition supply, signal communication, and liaison. Positions which probably will be occupied are organized and fire is prepared. Artillery observation is organized for each subsector.

If the enemy succeeds in forcing a landing, employment of the artillery conforms in general to the principles governing its use in the defensive.

* * * * *

A hostile landing force will strive to secure, in the following order:

a. A toehold on the beach, from which infantry can reduce beach defenses and secure an area along the shore protected from small-arms fire and grenades, so that further waves of boats can be beached without too severe losses. Historically this toehold has usually extended only to the banks or sand dunes just beyond high water

¹*Naval Gunfire Support of Landing Troops*, by Lieut R. C. D. Hunt, U.S.N., April 1942; *Sea Artillery*, by Captain E. S. Bechtold, FA, May, 1942.

mark. From this the attackers will push resolutely inland to secure:

b. A line which will protect the landing from machine guns and mortars. This line therefore is about 1800-2500 yards from the beach. The attacker will attempt to secure it prior to nightfall of the first day of the invasion.

c. An intermediate position protecting the beach from effective light artillery fire.

d. A *beachhead* protecting the landing from medium artillery fire. Having secured this line, the attacker can now land heavy materiel and stores. As soon as this is done he will organize and launch an offensive against strategic objectives.

The defensive should be installed with the following priorities:

(1) Organized defensive position within machine-gun range of the beach. This is not a continuous line, but consists of mutually supporting "strong points"² containing, say, a battery of light artillery or assault guns, a company of infantry, a platoon of engineers, and some antitank guns. This island of defense is protected by mines and obstacles (natural and/or artificial).

(2) Outpost position on or immediately in rear of the

²These are not *strong points* in the World War I sense of the word which meant merely a trench system occupied by an infantry company. It now refers to a *combat team* of several arms.

beach. This is mostly for observation and warning, unless it has been decided that a landing must be prevented at all costs, in which event the actual beach defense will be strengthened according to available means. The outpost may consist of patrols, perhaps motorized or even armored. It will have automatic small arms. Beach guns (light artillery) may be used if knowledge of the hostile landing areas is sufficiently exact, but it must be remembered that such weapons usually have no transport and are apt to be lost.

(3) Organized defensive position within artillery range of the beach. This must consist of an elastic defense in depth, but may be strengthened by permanent works such as pill boxes, antitank ditches, concrete gun emplacements, and protected OP's. This position should have commanding observation.

(4) Organized localities to prevent lateral movement of hostile groups who may have landed and reduced the more forward defensive position.

(5) One or more battle positions between the defensive position listed under (3) above, and the probable hostile objective.

Sketch 1 shows the schematic plan for the defense of a sector. Sketch 2 shows the allotment of units to a sector garrisoned by a corps of three motorized divisions. Such plans, of course, will vary greatly with the terrain and situation.

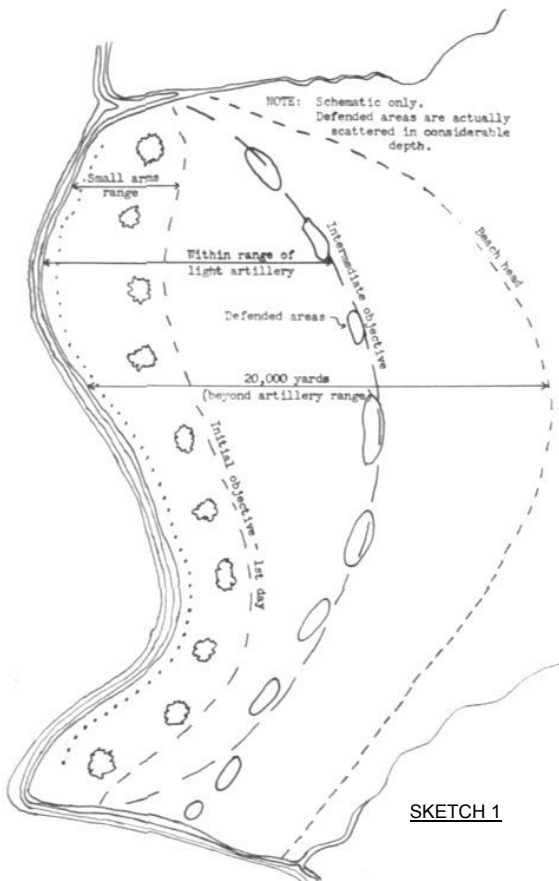

SKETCH 1

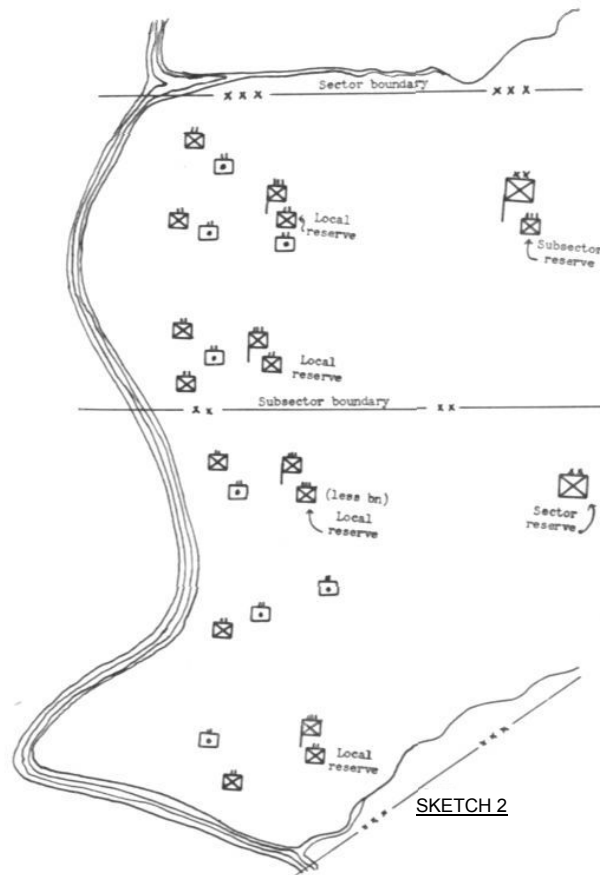

SKETCH 2

DETAILS

Application of the foregoing principles will vary widely between limits imposed by the two extreme cases where (1) a small island is to be defended, with a very short coast line and little or no space for maneuver inshore, and (2) an extensive coast of a large island or continent cannot be defended everywhere initially, but where the inland maneuver terrain is practically unlimited.

In the latter case artillery methods will be quite standard, except possibly for the actual resistance offered at or near the beach. Therefore let us confine our remarks to the more unusual case (1). Suppose for the purpose of discussion that our defending force is sailing from Miami, Florida, to occupy and hold one of the smaller Ryukyu Islands, between Formosa and Nagasaki (we can *suppose*, can't we?). At once we can assume that any force that attacks us after we are there will consist of Tojo's boys rather than Adolf's; no need to speak awkwardly of the "Reds" and the "Blues." From now on let us place ourselves in the shoes of the field artillery commander of our hypothetical defending force, and remind ourselves of a few of the many things he would have to consider.

The defending force is just coming ashore. Luckily (!) the Japs haven't discovered the movement as yet, but they may show up at any moment. What shall the field artillery commander do first? Make a reconnaissance, to be sure.

In his initial reconnaissance for installations, the artillery commander should operate in close coordination with any Navy authorities who may be present. This is not so much a matter of "paramount interest" or supreme command, which will be specified by orders from higher headquarters, but of settling certain details on the spot and preventing certain serious mistakes. For example, it would be fatal to select a gun position near where the Navy intended to erect a fuel tank. In case the tank were struck by hostile fire, the heat might drive away the gun crews at a critical time, or the smoke obscure their field of view. In any case the artillery commander should seek out and consult the Navy representatives. They probably will have much information not ordinarily available to the Army.

Field artillery commanders are versed in the tradition of the arm, in which the care of animals, materiel, and supplies is frequently given precedence over care of personnel, especially after a march or when going into position. In occupying an island, this order of priority must be reversed. The components of the unit are vulnerable to hostile action in the following order: personnel, supplies, materiel. They should be protected in that order, for the preservation of all is vital. Hence personnel shelters should be constructed immediately upon landing or, if possible, this should be done by an advance party before the main force arrives. In this case, as in everything, DISPERSION is the foundation of protection.

In most of the small islands, where there is no room for a defense in depth nor for extensive and extended land operations, the assault must be repelled while the enemy is on or in the water. He must be *prevented* from landing. Gun positions must be located with this in view. However, preliminary hostile fire from naval units, and even from the air, is most effective against installations which (initially, at least) are so close to the water's edge that they are plainly visible and where the shore line provides a perfect adjusting medium. The loss of a few hundred yards of range is more than compensated for in the protection afforded the main batteries by locating them somewhat inland. They must, however, be sited for direct fire, and their arcs of fire must cover the maximum amount of water approaches. A thought to keep in mind is this: The Skibbies (Japs) may be repulsed in their first, or even in their second, third, or fourth attempts to land. But they are persistent. They will keep attacking from the air and from the sea until one by one they have reduced the shore batteries. Then they will send in their landing parties. Hence the wisest course is to exercise sufficient prudence in the location of guns to insure that they remain in action for a long time, rather than to be governed unduly by a desire to be bold and demonstrate an offensive spirit.

For weapons of smaller caliber, a different scheme is suitable. Some of the 75's and the smaller automatic weapons should be near the beach to repel "sneak" invasions. A large reserve of these, however, should be withdrawn initially from the shore. Skibby's bombardment of the shore line will be designed to destroy beach guns and automatic weapons. Then, as his boats approach the shore, the fire will lift and the beach will be the safest place for our troops. At this moment the commander must order his mobile light cannon and automatic weapons to displace rapidly to previously selected and prepared positions on the beach, and open fire on the enemy as he approaches the shore. As the landing may be attempted under cover of darkness, fog, or smoke, provision (survey, aiming stakes, etc.) must be made for laying down bands of unaimed fire. During this period, the heavier batteries should continue to engage the hostile transports and other large vessels and to execute counterbattery on the enemy warships which will be moving rapidly and by irregular courses nearer to shore to deliver their fire. In directing the close defenses of the beach the commander must withhold a reserve, especially of armored artillery and tanks, until he is sure that the main effort has been disclosed. In preparing installations, adequate initial protection must be provided for these units. This may consist of bunkers and slit trenches dispersed yet provided with roads or trails leading to the beaches. Some system for guiding groups and vehicles to predetermined points under cover of darkness or fog must be worked out, either by installing illuminated markers or by otherwise indicating the route by tape, etc.

A study should be made of the location of the reef. Around many islands is a reef at distances varying from a few hundred yards up to several miles. Openings in the reef and areas where it closely approaches the main shore lines are places to watch. The Skibbies have attacked in one or more instances where the reef was close enough to the shore to permit their destroyers and cruisers to come within effective gun range. Ordinarily there is not more than four feet of water over the reef at high tide. This will not prevent landing boats from crossing it at any point. The configuration of the reef will be a factor in the selection of positions for main gun batteries.

Guns should be emplaced in pairs, so as to provide for at least one gun's being in action at all times. They should be spaced sufficiently to prevent loss of both from a single shell or bomb. Arcs of fire should cover the entire water area and beach, and should overlap, especially at the critical areas. Alternate and dummy positions must be provided.

Gun positions should not be near easily recognized landmarks, either natural or artificial.

The best type of emplacement for the main batteries is a unit constructed of reinforced concrete, having strong protection along the sides and sufficient thickness overhead to withstand fragments of bombs and naval shells. The emplacement contains a "ready magazine" and shelter for personnel, integral with or connecting with the gun pit. The personnel shelter should be capable of being made gas proof. The parapet in front of the gun should slope away at a sufficient angle to reduce the likelihood of raising an obscuring cloud of dust each time the piece is fired. Additional means may have to be taken to reduce dust during action, for it will be vital to continue a high rate of fire during the critical part of the fight.

Shelters and emplacements for automatic weapons should receive some protection, usually from sandbags. These rot quickly, hence should be "grouted" by being given a wash of cement and water which hardens and protects the surface. This is applied after the bag is filled. In any type of installation, it should be kept in mind that the widespread use of tracer ammunition and incendiaries of various kinds during this war has made the casualty rate from burns increase tremendously. Inflammable material should be avoided as much as possible, and means for combatting fire should be provided liberally.

All installations of a major character must be protected by mine-fields, barbed wire, and other obstacles, for defense against personnel on foot and in armored vehicles. This will require the use of numerous personnel mines as well as antitank mines. Barbed wire should be installed in triple belts, separated sufficiently to prevent the enemy from throwing grenades or projecting flame from flame throwers across the entire belt. The Japs are adept at crossing wire. They carry coco mats for this purpose, and a single, narrow belt of wire will not stop

them for a moment. All wire must be covered by fire of automatic weapons.

Mine fields should be above the high-water mark, and located especially to cover areas not effectively reached by gunfire from the main batteries. Mine fields should be covered by automatic weapons. Their location must be known to all friendly troops, and some system worked out to prevent their being entered by friendly patrols at night.

Warning devices, such as tin cans tied to strings, cow bells, etc., will be useful in providing supplementary warning at night against raiding parties approaching the position.

Coastal sand dunes are usually covered with a sparse growth of shore plant which provides a somewhat variegated ground pattern. This should be disturbed as little as possible in constructing gun emplacements. Effort should be made to blend the position into the dunes, so that it resembles a dune. Canvas may be painted, sprinkled with sand while the paint is fresh, and bits of vegetation fastened to it at intervals for use as a camouflage cover. The positions should be inspected and photographed by friendly planes. It may be well to locate the gun between the natural dunes rather than disturb the earth by removing large heaps of sand. The Germans have been very clever at this in emplacing their guns along the English Channel; they have even concealed their long-range cross-Channel guns by running them into huge tunnels in the sand dunes when not actually firing. The entrances to the tunnels are concealed by great pieces of canvas made to look like sand and vegetation.

Perhaps the most stupid thing a commander could do would be to construct a warehouse and place his supplies of food, ammunition, etc., therein. All supplies must be DISPERSED in small caches, and protected by bunkers or other shelter. Telephone and telegraph cables should be buried. Alternate circuits and cross-connected nets should be provided. Test stations should be installed at frequent intervals. Provision must be made for every possible means of communication, especially by use of pyrotechnics.

Timely arrangements must be made with the Navy to insure coordinated use by land, air, and sea forces, as well as friendly commercial shipping, of suitable recognition signals (by radio, flag, light, pyrotechnics, etc.) to prevent fire on friendly units.

When the first alarm comes it will be natural for the commander to turn out his entire force. This temptation should be resisted. Regular reliefs should be organized beforehand, and these should be adhered to rigidly. The defense of an island will be in the nature of a siege; the personnel must get sufficient rest, or the defense will soon crumple from the physical exhaustion of the men.

In addition to intensive training in all the usual field artillery methods of fire at moving targets, batteries should receive instruction in Coast Artillery methods of

firing "on the bell" at sea-borne objectives. Training literature on that subject is available and adequate. Training in firing should be conducted under battle conditions, at night, during fog or smoke, and during rain storms. Frequent "alert" drills should be practiced. In every case where the Jap has attacked, he has gained some surprise because some gunners, especially those manning anti-aircraft weapons, were not at their stations. Arrangements should be made with the Navy to provide craft for towing targets during practice, if boats for this purpose are not otherwise supplied. Special attention should be given to practicing ricochet fire. The new PD fuzes will arm on impact with the water, and projectiles

will ricochet at angles of impact of less than 215 mils. Ricochet fire against landing boats as they approach should be highly effective.

All personnel should be able to "double in brass." For the purpose of insuring this, frequent casualty drills should be held.

All personnel must be given thorough instruction and frequently repeated tests in identification of hostile ships and aircraft. Included in the above there should be given to gun crews some instruction in the vulnerable portions of hostile ships. Hits, even of large-caliber shells, on certain parts of warships do practically no damage. To a lesser extent this is true also of unarmored vessels.

JAPANESE LANDING BOATS

The Japanese landing-craft carrier is a special type of transport similar in construction to a whaling depot ship. From it, landing craft loaded with full complements of men and materiel are slid into the sea through side hatches. One of these Japanese troop-ships was reported by an observer to be about 260 feet in length.

Type A landing craft is a large open boat, with a landing ramp on the bow which flaps forward onto the sand, enabling guns to be wheeled off. The engine and the coxswain are usually protected by bullet-proof plating. Twin keels provide stability after grounding. This type of boat is used by the main landing force. It has an estimated capacity of 110 to 120 men, fully equipped, and is powered with a two-cylinder gasoline engine, with a speed of approximately ten knots. In a few cases, Diesel engines are used. The over-all length is about fifty feet, and the beam about thirteen feet. The loaded mean draft is slightly over three feet.

Type B is a small open boat, holding from 50 to 60 men. Its speed is from 8 to 10 knots. It is similar in construction to a steamer lifeboat, and when fully loaded has a draft of thirty inches. Some boats of this type are equipped with a bullet-proof shield in the bow. Some are known to carry a light machine gun in the bow.

Type C is an armored motor launch used for close support work, reconnaissance, and maintenance of communications. It has an over-all length of about forty feet, and a beam of about thirteen feet. One boat of this type was clocked at fifteen knots. It carries an anti-aircraft machine gun and two machine guns or one-pounders.

Type D is constructed solely as a tow boat. It is used to supplement the large Type A open boat. It has a wooden hull, similar to a standard motor launch. Its over-all length is approximately thirty feet and beam ten feet.

Type E is airplane-propeller-driven, for use in shallow water or in creeks, smaller tributaries, and weed-bound water. These boats are approximately fifty feet in length and not over ten feet abeam. Judging by the bow spray in a photograph of one heading down a river, about ten feet of the forward underwater body rises above the water. The draft at light load is probably not over two feet. The craft is steered from forward under the canopy. There is a shield for a machine gun in the bow.

Type F, which is constructed of steel plates, is in two sizes—thirty feet over-all, and forty feet, with twelve-foot beam. It is constructed of steel plates. A metal shield is rigged in the bow for protection. In this shield there is an aperture for a machine gun. One of the large ones was clocked at nine knots.

In the Philippines, the typical Japanese procedure in landing operations seems to cover about five miles of beach. A line of destroyers forms about a half-mile from shore, with a heavy cruiser or battleship about three and a half miles beyond the line of destroyers. Two groups of transports remain between the destroyers and the heavy vessels. An aircraft carrier stays between the two groups of transports. Then about fifty barges with a capacity of 150 men each start for shore, each barge being armed with two or three machine guns. Naval vessels are in a position to fire upon the beaches, and they can also deliver effective anti-aircraft fire, which is extremely heavy up to about 3,500 feet. Machine-gunning, observation, and pursuit protection are provided by aircraft carriers and landing fields already established.

The Caissons Go Rolling Along
Copyright 1930

March Tempo

E. L. Gruber

The musical score is arranged in three systems, each with three staves. The first system is labeled '1st Bugle', '2d B-', and '3d B-'. The music is in 3/4 time and features a variety of rhythmic patterns, including eighth and sixteenth notes, and rests. The second system includes first and second endings, marked with '1' and '2' above the staves. The third system also includes first and second endings, with the second ending concluding with a double bar line and repeat signs.

THE FIELD ARTILLERY SONG was composed in the Philippines by the late Brigadier General Edmund L. Gruber thirty-odd years ago. It is appropriate at this time to publish (with the permission of the copyright owner, Shapiro, Bernstein and Co., Inc.) this field-music arrangement.

SOLUTIONS TO CADRE TESTS

(See page 430)

Note: Answers which depend on particular materiel, organization, etc., are omitted.

INSTRUMENT SERGEANTS Part "A"

1. *a.* Aiming circle, battery commander's telescope, prismatic compass, range finder, and field glasses.
- b.* Alidade, plotting scale, protractor, straightedge, plane table, time-interval recorder, steel tape, thermometer, and declinator.
2. *a.* The north to which a compass needle points.
- b.* Arbitrary north on military maps.
- c.* Clockwise angle from any north to the point sighted upon.
3. *a.* Compass, and horizontal and vertical angles.
- b.* Horizontal and vertical angles.
4. Set up over a point from which several points of known azimuth can be seen, preferably in different compass quadrants. Set scales at zero. Center needle. Turn to known points with upper motion, and read. Check by repeating through several complete circles. Subtract mean of three readings to each point, from the known Y-azimuths. The average of the differences is the declination constant.
5. Set index and micrometer at zero with upper motion. Level instrument. With lower motion bring vertical hair to the point from which measurement is to be made. With upper motion, turn vertical hair to point to which measurement is to be made. The reading of azimuth scale and micrometer is the measured angle.
6. Level instrument. Level telescope by rotating elevation knob until bubble is midway between graduations on the level-vial. Sighting through telescope, note on reticule the reading that is level with the object whose angle of site or vertical angle is desired.
7. Infinity method and known-range method.
8. Tighten screws and clean externally.
9. Draw on the sheet on the table a line which can be seen on the ground. Sighting over at least two points on the drawn line, align it with the actual line on the ground.

Part "C"

5. Set up the aiming circle where the sight of every gun in the battery can be seen. Set on the aiming circle's scales the difference between the declination constant (increased by 6400 if necessary) and the compass desired. Center needle with lower motion. Clamp the needle. With the upper motion, swing to each gun in turn and call off the reading. Repeat until all readings to a given gun differ by not more than one mil.

OPERATIONS SERGEANTS Part "A"

1. F	9. F	17. F	25. T	33. F
2. F	10. T	18. T	26. F	34. F
3. T	11. F	19. F	27. T	35. F
4. F	12. T	20. T	28. F	36. F
5. T	13. F	21. F	29. F	37. T
6. T	14. T	22. T	30. F	38. F
7. F	15. F	23. F	31. F	39. F
8. F	16. F	24. T	32. F	40. F

Part "B"

5. *a.* The north to which a free-moving compass needle points.

- b.* The north on military maps.
- c.* The horizontal clockwise angle between north and any other point, vertex at the observer.
6. Air-Ground Liaison Code, Fire Control Code, M-94 Cipher Device, Division Field Code, Prearranged Message Code, Meteorological Code, and Pyrotechnic Code.
7. See sketch.

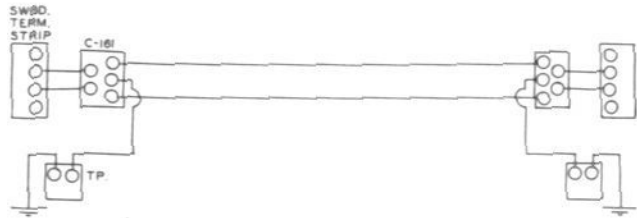

8. Wide-angle photos, single verticals, obliques, and mosaics.
9. By type of fire: concentrations, standing barrage, tolling barrage, box barrage.
By tactical employment: counterbattery, neutralization, harassing, preparation, interdiction.
10. An observed fire chart is a diagram accurately constructed to a known scale, showing the relative positions of batteries, base points, base lines, check points, targets, and other data, construction of which is based on data obtained by registration, by survey, from map data, or a combination of these, designed to: (1) provide a quick determination of initial data for observed fires, and (2) provide a quick and convenient means of recording adjusted data. It is principally limited in use to those fires which can be observed, since its accuracy is not sufficient for unobserved fires.

Part "C"

1. Ca, 3806; map range, 2870; site, —5.
B Adj, Sh HE, Ch, FQ, CA 3810, FO 3, Si —5, B ①, Zone, 2850.
2. 2033 yards.
3. 1238*m*.
5. "A," 87.310-48.280; "B," 89.075-48.945.
7. "A," 424'; "B," 488'.
8. 1%; 11*m*.
9. +11.5*m*.
10. See sketch.

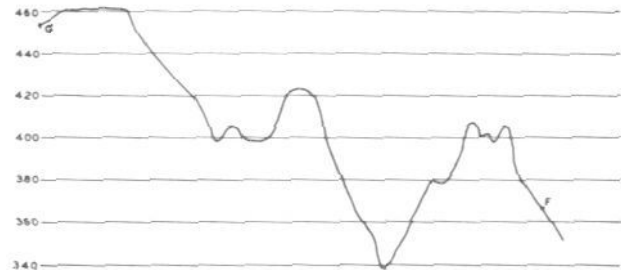

12. 1918 yards.

Ammunition in Combat



Life

The importance of the supply and serviceability of ammunition can be appreciated only by those who have to deliver a great volume of fire and who find that on account of negligence, there is no ammunition to shoot. The shortage may be due to lack of foresight in supply, to damage caused by improper methods of transportation or storage, or to the loss of a complete supply of a single component caused by "putting all the eggs in one basket." The following duties or precautions should be observed by the ammunition corporal and where applicable by others whose duties are connected with ammunition to provide an adequate supply and prevent needless losses.

HANDLING

Care should be observed to see that containers are not damaged, and that the rotating bands and bourrelets of projectiles are not burred by rough handling. Ammunition must be carried, not dragged, thrown, or dropped. Only the amount required for immediate use should be prepared for firing.

TRANSPORTATION

Checks should be made to see that vehicle tops are up to protect against the damaging effects of rain and of the direct rays of the sun; that loads are properly secured to prevent damage in transit (separate loading projectiles should be held in ammunition frames); that the trucks are driven carefully to avoid sudden stops and tossing of the

cargo; that the rated capacity of the trucks is not exceeded; that there is no fire hazard from smoking or from defective wiring on the trucks; that fire extinguishers are carried; that no combustible material is transported with ammunition; that all personnel have been instructed in their duties in case of fire; that components of separate loading ammunition are distributed among several trucks to minimize the danger of losing an entire supply of one component; and, that each type of chemical shell is transported in separate vehicles.

(NOTE: Recent changes in regulations permit the carrying of complete components of separate loading ammunition, including fuzes and primers, in one vehicle by combat units.)

FIELD STORAGE

Minimize the effects of heat and moisture by keeping the stacks covered. Prevent direct contact with the ground and allow proper ventilation under the covering and through the stack by the use of dunnage.

Prevent the loss of ammunition by enemy fire and by sympathetic detonation. (This may involve both digging in and scattering of the piles at least 10 yards apart to prevent the loss of more than one pile.)

To prevent the complete loss of a single component of separate loading ammunition, components should be distributed among several piles.

Do not exceed prescribed amounts in any one pile (105-mm. howitzer ammunition — 4 layers high, 75

An authoritative, down-to-earth resumé of a matter more units must consider daily.

rounds in one pile; 155-mm. projectiles—3 layers high, 50 rounds in a pile).

Have in one pile all ammunition of the same lot number.

Stack so as to permit easy inspection of lot numbers and rapid detection of unserviceable ammunition.

Have pyrotechnics, smoke, and other chemical ammunition stored separate from each other and from all other ammunition.

A site should be selected where there is good drainage, where there is a road nearby if possible, which is not too close to or directly in rear of the battery, and where camouflage can be effected most easily.

See that the stacks will not collapse (use battens or braces at the ends).

Have the most sensitive elements isolated or given special protection.

SPECIAL SAFETY PRECAUTIONS

Gas masks, protective clothing, and decontaminating agents should be available for handling chemical ammunition.

Water should be available for extinguishing white phosphorous fires.

Ammunition data cards should be saved. In case of an accident, this foresight may result in the saving of many lives by the withdrawal of faulty ammunition.

All powder-train fuzes should be set at "safe" and cotter pins replaced in fuzes and boosters before the fuzes or rounds are returned to their containers.

All unused increments of powder charges should be collected and destroyed by burning.

Stuck fixed and semi-fixed rounds that can not be removed from the bore by firing should be unloaded by means of the special unloading rammer; separate loading shell should be removed by firing.

All grass, brush, and other combustible materials should be removed from the vicinity of ammunition stacks unless needed for concealment.

Never disassemble a loaded component.

MISFIRES

(1) For separate loading ammunition, a primer that has misfired may be removed at any time by using the special issue primer removing tool. If the primer has fired, peace-time regulations require a wait of ten minutes before unloading.

(2) Fixed or semi-fixed ammunition—wait two minutes after last attempt to fire before unloading.

SALVAGE AND RECORDS

All cartridge cases, containers, etc., should be piled for such collections as may be directed.

Complete records should be kept of the amounts on hand, in each vehicle, in the dump, and the amounts received and expended of each component by type, model, and lot number.

INSPECTION

In addition to an inspection that the foregoing precautions are observed, a detailed check of the components should be made to cover the following:

Projectiles should be inspected to insure that there is no exudation of the contents, that they are correctly assembled, that the bourrelet and rotating band are smooth and free from large dents, and that the threads of the adapter are clean. Field artillery projectiles should be clean and free from grease except that the 240-mm. howitzer shell is given a light coat of grease immediately prior to firing.

Propellants of fixed ammunition cannot be readily inspected, but those for other ammunition should be noted when preparing the charge. Care must be exercised to insure that only the proper increments are removed from the complete charge. There should be no leakage of contents from any of the cartridge bags. In the case of separate loading ammunition, the tag and igniter pad cover, if present, must be removed prior to loading the charge.

The *fuze* should be carefully inspected to ascertain that it is properly set, that no unauthorized removal of parts has been made, and that all necessary covers have been removed. The fuze should never be removed from fuzed ammunition. All separate fuzes must be tightened to the projectile with a fuze wrench whenever possible. When fuzes are issued, a check should be made from a permissible-fuze chart to see that the particular fuze is functionally safe for the particular weapon. With semi-fixed ammunition the packing stop must be removed from the projectile before firing.

As *primers* have a peculiar hygroscopic nature, their container cans should never be opened till necessary. Primers should be inspected particularly for signs of corrosion.

Cartridge cases should be carefully inspected for cracks or dents which may affect their functioning or the functioning of the weapon. Badly corroded cartridge cases will increase the difficulty of extraction or may result in split or ruptured cases. Cases with faults which may result in a rupture should not be used. Their use may place a weapon out of action for a considerable period of time while the ruptured case is being removed. A deformed mouth may prevent the cartridge case from seating, and, if fired in this condition, a serious blowback may occur.

ROAD TO DUNKIRK

EDITOR'S NOTE: *In the first two chapters, Marquis de la Falaise described his joining a British mechanized squadron as liaison officer, when the Germans invaded the Low Countries. Fighting continuous rear-guard actions, this unit was in almost constant contact with the enemy from east of the Dyle to the Brussels area. This instalment opens a mile northwest of Braine, toward Halle.*

By Henri de la Falaise

Leaves from my diary in Flanders

Chapter III

FRIDAY, MAY 17TH

The new day is only a few minutes old when we reach the armored cars of the HQ Troop, about two hundred yards from the top of the hill on the counter-slope toward Eschenbeek. The fighting lorry and the staff car are on the extreme side of the road, against the walls of a farm, and turned toward Halle. The armored car, in which John is talking to the colonel over the wireless, is under a thin tree in a track leading toward a large wood. Elliot's armored car is a little further away on a cart road, behind a short hedge. The third car has been sent to reinforce Phil's troop in Braine le Chateau, as there are three more small bridges to guard there, in addition to the larger one where I was an hour ago.

Elliot is very dissatisfied with our present position, as we do not have a commanding view; if an enemy patrol succeeded in getting through at Braine, it would be on top of us before we could do anything about it. Furthermore, the night is pitch dark. The stars and the moon are hidden by thick clouds, so he decides to send me to the top of the hill with a party of men on foot. I take Machin, the driver of the staff car, and three other men from our reserve in the fighting lorry, a Boys anti-tank rifle, and a Bren gun.

We dig two shallow emplacements for the guns to the right and left of the road, then I sit in the ditch and light my pipe. This hill rises about three hundred feet above Braine and the valley toward Clabeck. After a while the sound of machine-gun fire reaches us. It comes from Peter's troop in the valley to the left. Far away in the distance the sky is still red. From our position we command the road ahead and have a clear field of at least three hundred yards, yet we are practically invisible; we could, if needed, put quite a few of the enemy out of action, and give time to the troop back of us to get into fighting formation. I send Machin to Elliot with a message to that effect.

I get orders to move forward a quarter of a mile to a group of houses at the crossroads to Lembeck, and to Sart Wood. HQ Troop armored cars, the staff car, and the fighting lorry are to follow us. This new position is just half a

mile short of Braine and at mid point of the hill. It is a much better site, as it affords shelter and two lines of retreat.

Two of the farmhouses are still occupied by their owners. I bang on their doors to warn them to remain inside, whatever happens. In the second farm, I am greeted by a rather pretty young woman, who has just got up from her bed and is in such a state of fright that she doesn't seem to notice that she is half naked. She begs me to let her depart with her small child and her old father, who is an invalid and can hardly walk. She falls on her knees to implore me, and is so beside herself with fear that she trembles all over, like a frightened animal. I try my best to quiet her and talk to her father, who is much more sensible and agrees that there is no possible chance for them to escape now. She finally calms down and accepts our advice. Following my suggestion, she goes to the cellar, with her child wrapped in blankets. The grateful old man gives me a pail of fresh milk, which I carry to the armored cars where Elliot, John, and the men receive it with great joy. I drink two bowls of it myself, and it makes me feel warm and comfortable. Our last sandwich was eaten over twelve hours ago.

At 2:30 John receives the news over the wireless that a company of infantry and an anti-tank company are being sent up to reinforce us from Halle. Peter phones that he is being fired at from close range, and has had to change his position slightly. Phil reports that he hears motors on the hill beyond the river and sees flashes, but that no attempt has yet been made to get near the bridges.

Bombers fly over, very low, heading for Halle. A few minutes later we hear the distant thud of their bombs exploding. Our reinforcements must have tasted some of them. More bombers are coming. Their black shapes are only a few hundred feet over us. They too are going to Halle. Elliot thinks that they are trying to destroy the bridges over the canal, our only line of retreat. He decides to send me across the canal, with the staff car and the fighting lorry. I am to find a sheltered place on the Halle-Edingen road which runs roughly parallel to our position, but on the other side of the canal.

I leave at once with the staff car, the lorry and two dispatch riders. Our first job is to get through the streets of Halle, which are still being bombed. Several houses are burning in the neighborhood of the bridge and there is a great deal of wreckage in the streets; some are entirely blocked. Happily, there seems to be a lull in the bombardment while we get across the town. My driver is very nervous and stalls the car twice. We see quite a number of British soldiers about. They are all marching in a single file toward the bridge, by small sections, keeping against the walls.

We finally reach the Edingen road. When I find a suitable spot three miles from town, we drive the cars to the side of the road under some very thick trees and halt. I give the map reference to a D.R. and send him back to Elliot. It is about 03:15 hours and the night is very chilly, so I sit in the back of the staff car with Machin and decide to sleep a bit.

Am awakened by Roddick who has come to fetch me in his armored car. I feel better after an hour of sleep. Day is

breaking, and as I get out of the staff car I see the dead bodies of two Belgian motorcyclists lying on the road about thirty feet ahead. They are riddled with bullets and must have been machine-gunned from an enemy aircraft last night. Perhaps while I was asleep. "It seems that things are getting lively down by the river, and Elliot needs your company," says Roddick, with a smile.

The fighting lorry is to stay with the R.E.'s lorry and wait for further orders, as it would not be healthy for them to be left here on the side of the road in broad daylight. I find a good hiding place for them a quarter of a mile up the road, under the trees of an orchard. The house it belong to has been squarely hit by a bomb. Bloody garments and baby clothes are littered all about the place. At the back of the house is a pig sty. It has been hit too, and a large sow is lying in it, dead and half decapitated. Between her sprawled legs, eight little pigs are squealing and pushing and poking their pointed pink noses into their mother's side, trying in vain to suckle the lifeless belly.

Roddick starts off in the armored car and I follow

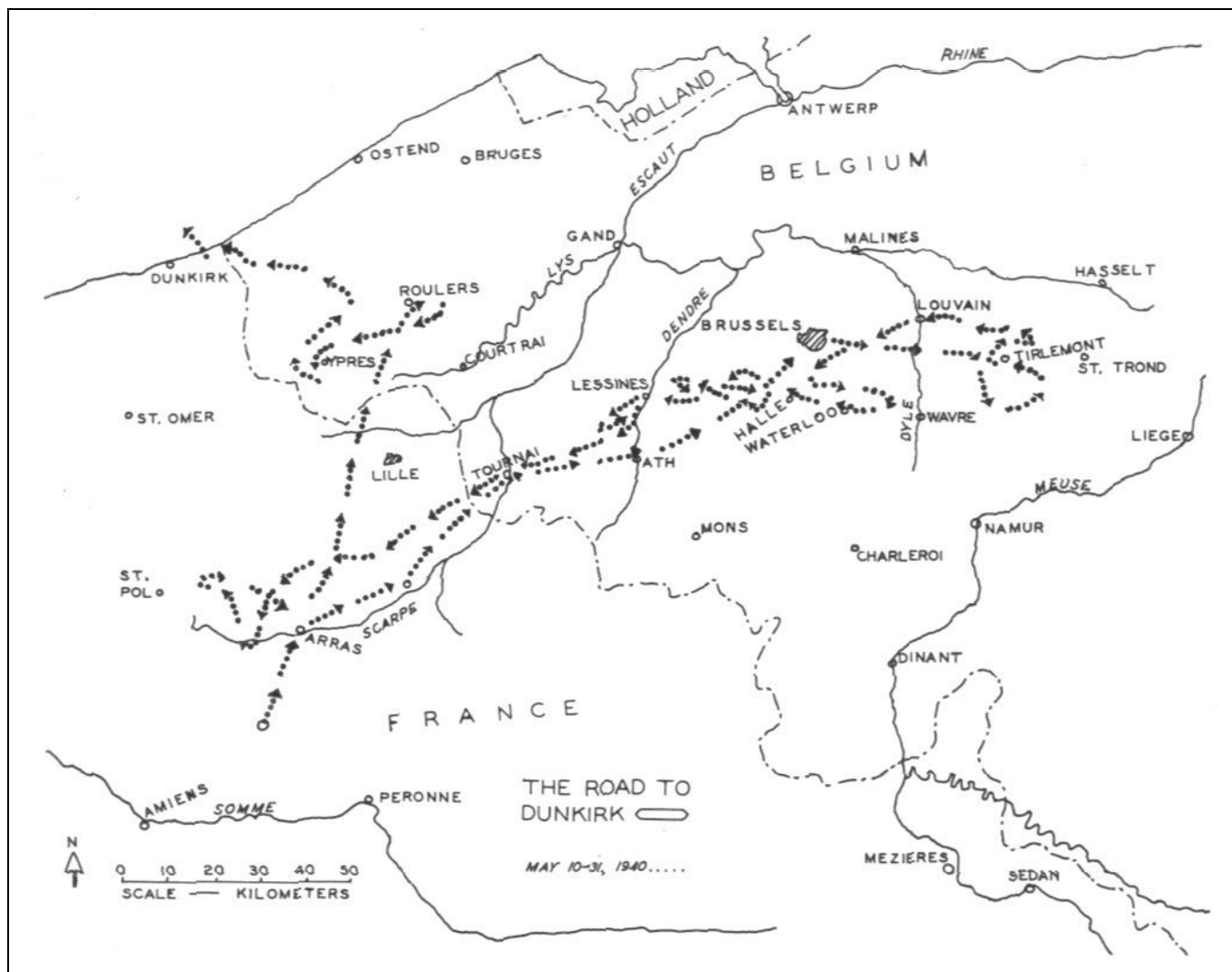

in the staff car with Machin and the driver. As we enter Halle, we can see the effect of the bombing attacks. The streets are filled with wreckage of all kinds and description. Houses are burning and just as we reach the main street, which leads to the bridge, we see soldiers running for cover and hear the rattle of machine guns. The armored car forges ahead and I urge my driver to follow it at fifty yards, and not to stop.

Just then bombs come screaming down all around the bridge, which is about two hundred yards ahead of us. If we can get across it before the Stukas have time to wheel around and come back for their next attack, we are safe. At fifty miles an hour, through the black smoke and the dust raised by the high explosives, our wheels bouncing over the fallen bricks and timber, we follow the armored car. We succeed in dashing over the bridge. The river is at least three hundred yards back of us and we are practically up the hill and out of Halle when the German planes launch their second attack on the bridge area. In the car no one has said a word. Now, as I look at Machin and the driver, I notice that they are very pale. I know that I am too.

I find Elliot and John in a deserted farm on the left of the road, on the far side of the village of Eschenbeek. British infantry and an anti-tank battalion that have come up after I left, are holding the heights over Braine le Chateau. The front line is about a half mile away, at the spot where I left Elliot a few hours ago. Our armored cars are on the hill with the infantry.

A ruddy-faced lieutenant colonel who commands the anti-tanks has made his HQ in the farm with us. His staff doesn't seem to appreciate the enemy aircraft, which keeps on thundering by only a few hundred feet over our heads. Some of the planes are so low that it seems they are bound to crash right into the tops of the farm buildings under the shadows of which we are crouching.

A young anti-tank subaltern timidly suggests that, perhaps, the R.A.F. pilots are still in bed at this early hour.

"Don't blame the b s," grunts his colonel, "but from the looks of things around here, I think they lie abed all day."

Everyone is really beginning to feel quite uneasy and even mortified about the unexpected and total absence of British or French planes. Since the start of the German offensive, enemy aircraft have had the sky all to themselves, flying always in perfect formation as in a peacetime air show. They have been practically undisturbed. Furthermore, Allied anti-aircraft batteries are conspicuous by their absence, and one can't help but feel that they are being kept in the rear for the protection of the staffs. The effect on us is far from happy!

I learn that the Guards have lost Louvain, and that the famous Dyle position, which was supposed to break up the German advance, has collapsed. The enemy, pushing forward vigorously on the heels of the retreating British forces on our left, is in the suburbs of Brussels. On our

right the Panzer divisions have reached Soignies, and are progressing toward Edingen.

Looking at the map, I can see that our small force before Halle is in great danger of being cut off from the rear, and as I look up at Elliot, he reads my thoughts, silently nodding his head with a sad smile. One thing is certain; if they succeed in destroying the bridge back of us, we are caught like rats in a trap.

A D.R. arrives from Phil's troop with a message for me to come at once to help with a wounded French soldier. I jump in the staff car and drive up the hill. Leaving the vehicle at the infantry company HQ, I walk over the crest, which is in full view of the enemy and follow the bottom of the shallow ditch along the road. Phil's car is hidden behind a small farmhouse.

The Frenchman is lying against the wall. Phil, who is leaning over him, straightens up at my approach. "I am sorry, Henri, old boy, it's too late," he says.

I look at the blood-caked uniform and the grey face of the dead man. He belonged to the Colonial Division. I take his identification disc and papers, write his name and number on a piece of paper, and place this in a bottle. A grave is dug immediately, and the corpse is put in it. I place the bottle in the grave. Bareheaded, we say a silent prayer; then we fill the hole with earth. All this is very rapidly done, as we are being sniped at. Then we run back to the shelter of the wall and with shaky hands light a cigarette. Phil is very tired. He has had no sleep nor food since yesterday.

I soon join Elliot and John at Eschenbeek. The enemy has reached the Waterloo-Brussels main road. They have occupied Sart-le-Comte, and Peter's troop has fallen back. Elliot lends me his binoculars and shows me the dust raised by the German armored cars on the road to St. Genesius, the very same road we drove down last night on our way here. On the edge of the Sart Wood, the anti-tank batteries are firing at them.

Roddick's and Peter's armored cars are on the height on our left and have engaged the enemy. I can hear their machine guns, and every now and again the sharp crack of a Boys rifle.

A D.R. from our R.H.Q. swings his motorbike into the farmyard. The infantry which are holding the line with us are to retire at once behind the Halle canal. They will withdraw one platoon at a time, and dribble down the road toward the bridge. Elliot calculates that two hours will elapse before the move is completed. The anti-tanks are to stay with us until noon, after which we will be left to our own resources.

Elliot and the artillery colonel discuss the possible merits, shortcomings, and danger of this retreat in broad daylight, along a single road offering no shelter, toward the one and only bridge which has been left open. John and I sit alongside his armored car. The sun is very hot and we are both dead tired, so we just suck at our pipes, stare at the flies buzzing over the manure pile, and enjoy the warmth and momentary peace.

Our meditations are cut short by several flights of Junkers which come roaring straight down the road in threes, their machine guns blazing. They zoom over us and a few moments later we hear the rending noise of their explosive bombs crashing around our bridge at Halle. For a quarter of an hour or more they come and go, some flying in wide circles over the bridge, others in line roaring up and down our road. They must have spotted our retiring infantry. Phil phones that he has been bombed, but has no casualties. He says the infantry has started down the road and he thinks some of them must have been caught in the holocaust.

Soon the first platoon passes our front gate. Many soldiers are wounded. They seem very tired. Their leader waves at us. I run out and talk to him. He seems glad to be going away from here, even if only temporarily.

11:00 hrs. One by one, the platoons have filed past the gate of our farm, on their way to Halle. We have been bombed twice but neither the road nor the farm buildings have been hit. I have slept about a half hour in the shade of a wood pile in the orchard. After pumping some cold water over my head and neck, I feel greatly refreshed and relaxed.

Returning to the farmyard, I find the artillery colonel giving his orders for the withdrawal, at noon, of his anti-tank guns. Elliot and John are sitting by their armored cars.

They have their earphones on and are listening to the reports from our troops. Peter and Roddick are doing very well on the left, although one car has been hit, and two men have been wounded. As for Phil and Tim, they report that they have fired at enemy patrols which have succeeded in getting into Braine. They have seen and fired at only one light tank or armored car. This enemy vehicle came up to the bridge at Braine and seeing that it was half blown up and not wide enough, or thinking that it concealed a buried land mine, backed up and disappeared.

From all this, it seems that only infantry threatens the Braine-Halle road on which we are, and that our real danger lies on our left. There Peter's troop must keep the German mechanized forces off the dirt road, which would lead them to the canal of Halle and eventually to the bridge itself, thus cutting us off.

12:00 hrs. The anti-tanks are withdrawing. Their colonel bids us farewell and leaves for Halle. We are alone now. An ominous and extraordinary silence has fallen over the countryside. We know that crack German soldiers are crawling silently through the woods toward the crest of this hill. Yet no sound of firing reaches us. The sun is blazing hot, the sky cloudless. No planes are in sight.

A half hour later our colonel calls up about the Halle bridge, just to remind us that it's the only one left; he

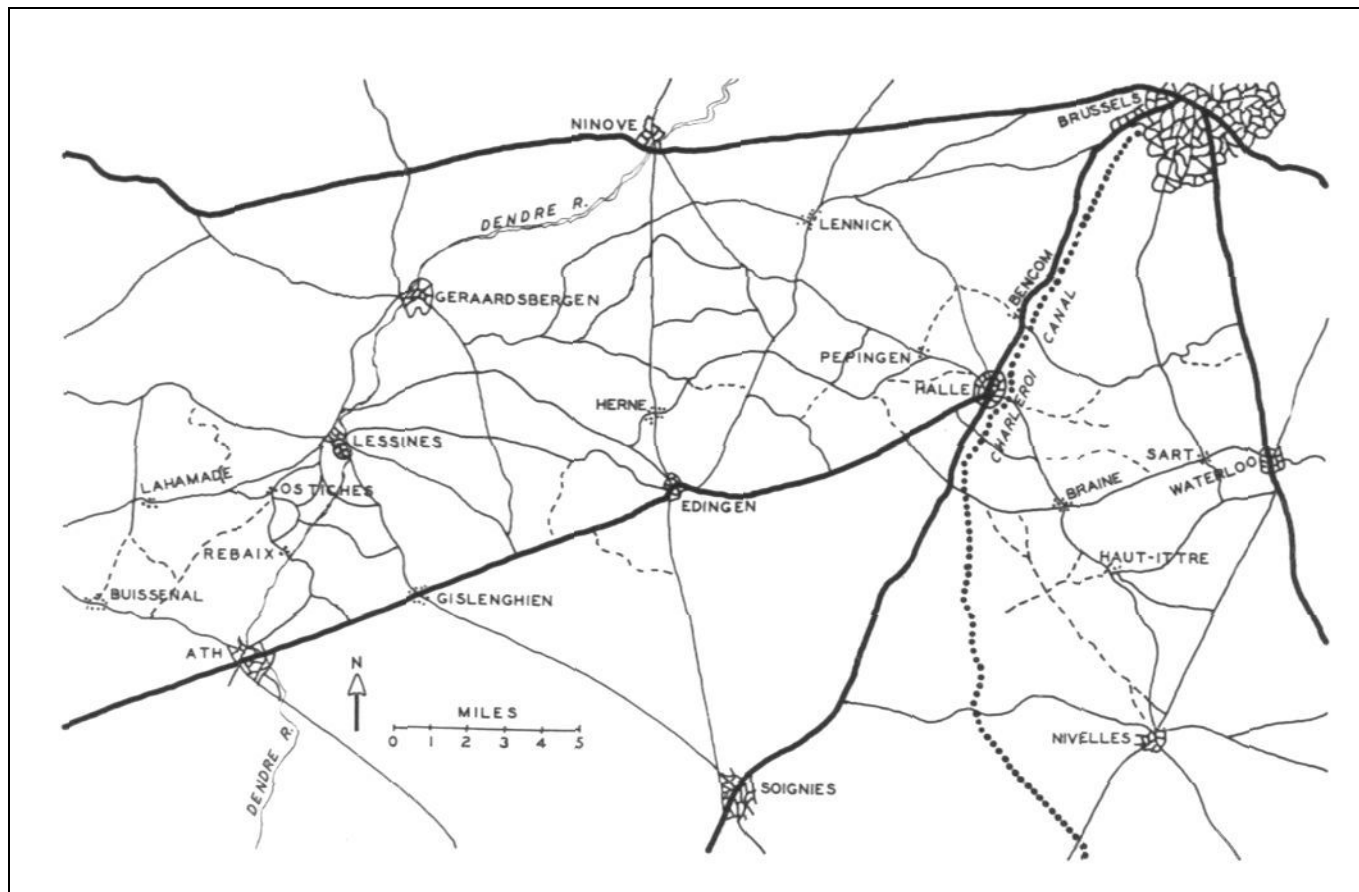

thinks we should make sure that no anxious R.E. blows it up, thinking that there are no more Allied troops on this side of the Canal.

"All right, colonel," says Elliot. "I'll send Henri to investigate and warn them."

The bridge has taken on a very warlike aspect since I saw it early this morning. To the right and left the Canal waters are crowded with sunken barges. The houses on both banks have caved in, wrecked by high explosives. The road bed is torn up, and we have to drive carefully to avoid huge craters and debris of all kinds. On the Halle side, the small square across the bridge has been hastily fortified. Machine-gun nests made of sand bags and large stones have been erected, and through a hole in the only remaining wall of an estaminet, a 2.5-inch anti-tank gun points its long thin muzzle.

Dozens of British soldiers are hurrying about, some bringing sandbags and stones to reinforce the positions, others carrying ammunition. Some R.E.'s are busy laying more land mines at the bridgehead. The central part of the bridge has been torn up in several places, and the holes are full of dynamite. All that is left to do now, to blow it sky high, is for someone to push a small button.

The men all look up as I walk across the bridge. My uniform and French Tank Corps steel helmet cause surprise. I deliver my message, and explain to the officers who have gathered around me that our squadron is holding the line of hills between here and Braine; that the only pressure from enemy tanks or armored cars is on our left; but that they have presumably headed due west, to try to cross the canal at Huizingen, a mile north of here. When the Germans find out that the bridge there has been destroyed, they might turn left and try this one, or go north and try at Leit.

They seem very grateful for this information and I leave the bridge with the promise that it will be kept open for us. Just as I am about to return to the car, I see Edouard M., my colleague at regimental headquarters, who has been sent here by the colonel with orders to stay at the bridge until our last car has crossed over safely. It is a great joy to see Edouard, and it cheers me up a lot.

A quarter of an hour later, I am back at squadron headquarters, and report to Elliot.

The minutes seem awfully long, now that we are waiting for the order to retreat. Standing here in the hot sun, in this messy farmyard, by the manure pile and its buzzing flies, we all feel uneasy and restless. No sound reaches us from the hill. Not a single shot breaks the terrible silence which surrounds us. The Germans must be moving up through the Sart Wood, between No. 1 and No. 2 Troops, unseen by them. There is nothing we can do about it; armored cars are made to fight on roads, not in woods. But we must remain here and obey orders. Our squadron will remain on the hill and mount guard, a

hopeless guard, since this ground is not to be held by the British troops, no matter what happens.

14:15 hrs. Elliot pulls off his earphones and tells us to get ready to leave; the order has come through at last. I am to go in the staff car and collect the fighting lorry and the R.E. light truck, which I have left this morning in the orchard on the Halle-Edingen road. Then I am to join the squadron at a point near Bencom, one mile west of Leit.

I leave at once and drive to Halle and over the bridge, as fast as the road permits. The sky is empty of Stukas for the moment. Edouard M. is still standing where I left him a while ago, on the tiny square beyond the bridge. Without stopping the car, I lean out of the window and yell to him that the squadron is withdrawing, is following behind me, and should be here shortly. He waves back that he has understood. As I look out of the rear window to catch a last glimpse of the Halle bridge, I can see his tall figure leaning against the sandbags of the machine-gun nest, with a carefree nonchalance worthy of the Ritz bar.

Avoiding the main street, which is strewn with nasty obstacles, we skirt the town, reach the road to Edingen, and find the orchard in which I left the two lorries earlier today. The men have made good use of a quiet morning, blissfully unaware of the enemy advance. They have washed, shaved, and made minor repairs on the vehicles. But when I show them on my map that the German tanks are barely a mile away, quick action follows. Fifteen minutes later I am heading for Halle, followed by the two lorries.

As we reach the top of the hill overlooking the small town, we hear, then see, the Stukas. They are circling and diving and raining small bombs on whatever is left to destroy. Black smoke is rising everywhere. However, we keep on, driving straight for this inferno. It would be murder to stop on the road now. They would be after us like hawks and there is no cover in sight. Pulling out my map, I try anxiously to find a dirt road which might lead us toward Bencom without going through the mess directly ahead. Just as we are entering the bombed area and see a huge tree crash a few hundred feet away, I find a small track on the left. We swing into it at top speed. It is rough going at first, but we manage to circle around the burning town.

An hour later, we are at the cross-roads near Bencom and find a D.R. waiting for us. He gives me a message ordering me to go on to Lennick, six miles from here.

17:00 hrs. Twenty-four hours have brought great changes to this little city. Most of the inhabitants have fled, closing their homes and shops. The cafes are locked up, the little house on the square where we billeted yesterday is shut, and we sit on the edge of the sidewalk, exhausted and in a daze. Coming from Brussels, a few civilian cars full of wealthy refugees cross the square. A driver tells me that the Germans are expected to enter

the capital tonight. Hunger, thirst, and despair are my only companions, as I sit here on the pavement gazing into space.

Elliot has gone to regimental headquarters to get orders. Phil, Peter and Tim are sitting on the sidewalk a few feet away, sound asleep, heads drooping on their chests. The sun is blazing hot, my body feels numb. I too close my eyes.

The touch of a hand on my shoulder wakes me up with a start. It's Elliot, back from headquarters, who tells me to jump into the staff car and go to Herne to prepare the billets for the squadron.

Nearly all the inhabitants of Herne have fled before the oncoming invasion. The houses are empty and the front doors locked, but I have to find lodgings for the troops, covered space for the armored cars, and a mess for the officers. So I go to work immediately, climbing over back walls and smashing windows. I succeed in opening up a few abandoned domiciles, and by the time the squadron arrives I have found room for almost everyone. An hour later the tired and hungry men of Squadron A are in their billets, and the cars are safely hidden in barns, sheds, or in orchards.

Our billet is an empty brewery; two armored cars of HQ Troop, the staff car, and their exhausted crews share it with us. It is very dark by the time everybody in the squadron is properly lodged. I drag my tired feet into the small dining room which, with two rooms above it and a small kitchen, formed the lodgings of the erstwhile caretaker of the brewery. There is a half empty whisky bottle on the table and the young subalterns are sitting around it, some on chairs, some on the floor. Those who are silently sipping the whisky are fighting hard to keep their eyes open. John Erne is snoring in the only armchair. In the adjoining kitchen, Elliot is taking what he calls his before-dinner bath. Machin is busily cooking canned sausages, canned soup, and canned potatoes, and with it all is also scrubbing the back of the major, who is standing stark naked between two pails of warm water.

Later on, when the food is brought to the table, we force it down our throats in silence. We are all much too tired to talk and, anyway, what would be the use to give voice to our thoughts? Only one thing is important, to try and keep as fit as possible.

The arrival of a dispatch rider from headquarters breaks the silence. He brings us orders to get whatever sleep we can and be ready to move off at any time after midnight. It is now 21:30 hrs., so with luck we might manage two and a half hours' sleep. We all scramble upstairs and lie down on the bare floor of an unfurnished room. There are five of us on that hard floor lying side by side. The major and John Erne are sharing the only mattress, in the next room.

SATURDAY, MAY 18TH

A sound of voices in the major's room wakes me up. I

look at my watch. It is ten minutes past one. It is pitch dark outside, but a new day will dawn soon, bringing German tanks, German planes, German bombs, the rattling of machine-guns, blood, and still more blood! All this flashes through my mind as I stare at the dark window, but I am still so sleepy that I really don't care what happens today or even if I will live to find out where we shall be tonight.

The situation as I hear it is not pretty. The colonel tells us briefly that Brussels has fallen to the enemy—so have Halle and Soignies further south. The B.E.F. is not going to attempt to hold the Germans on this line. Our regiment, however, is to stay here to try and delay the enemy while the infantry retreats to its new position ten miles to the west to make a stand back of the Dendre. We are again called upon to fight a rear-guard action.

3:30 hrs. One by one the armored cars file out through the dark and silent streets of Herne. We are heading east, towards Halle and the enemy. The countryside is covered with a low fog, heavy dew is falling, everything is cold and damp. I can hear no sound other than that of the squadron's motors. It is a peculiar sensation to be driving blind through fog and pitch darkness when death in the shape of a German tank might loom up ahead of you at any minute.

At dawn the squadron is halted just outside a small village about five miles east of Herne. We are on high ground and I can see the tops of the trees of what looks like a large forest lying to the south, between here and Edingen. Standing near his armored car, Elliot is giving out his orders to the troop leaders. They are going to spread fanwise to cover a five-mile front between Pepingen on the Halle-Ninove road and Saintes on the Halle-Edingen road. HQ Troop will move to a position near Bogaarden at the center of the squadron's line.

Fifteen minutes later Phil, Peter, and Roddick move off at the head of their troops. The HQ armored cars and the staff car follow shortly after.

5:15 hrs. We have just pulled up alongside a large farmhouse on the right side of a dirt road which runs through the hamlet of Den-Dail. Already a company of light infantry is established here. Their most advanced post lies across the road, about a hundred yards ahead of the spot where we have halted. On the right, just beyond the farm building, is a field of growing wheat occupied by a platoon of machine-guns. They are lying on their bellies watching the crest of the hill between here and Halle. To the left, an anti-tank gun is hiding behind a low wall. These men have been here all night and we are to relieve them.

The few houses which make up the hamlet of Den-Dail lie on the highest part of an elongated hill which affords a commanding view towards the east and the south. At the corner of the crossroads a few yards ahead of where I am sitting, is a sign-post marked on one side,

Pepingen 3 Km 800; on the other, Saintes 3 Km 200. We are in the center of the squadron's battle front.

Everything is strangely quiet here, and the sky is filled only with the glorious rays of the rising sun.

7:00 hrs. One by one, the infantry platoons have silently moved out of the village. Our small group and its three armored cars are its sole occupants. The men make tea, Machin has found some eggs, and we have a light and hurried breakfast sitting on the ground back of the farm buildings.

Inside the stables, the starving cattle are bellowing. The cows have not been milked for at least two days, their udders are terribly swollen, and the poor animals are wild with pain. As we have nothing to do for the moment, we untie them and chase them out of the stables and into a grassy meadow where they can find food and water.

A lone German observation plane is circling high above us now. This should indicate that the German armored units are moving forward. I don't think this Henschel can see us as we are very well hidden.

Peter reports that German tanks are moving along the Halle-Edingen road. That's where I was yesterday afternoon. Phil reports that he has opened fire on enemy tanks coming from Halle and on the Ninove road. Ten minutes later he reports that the tanks have withdrawn. Coming from nowhere, and flying so low that it seems as if they are going to touch the roof of the farmhouse, three large planes roar over us. I can see clearly the bombs under the wings. They pull up sharply over the last houses and disappear towards the west.

10:00 hrs. We have been here five hours now, and the warm sun, added to the monotonous drone of the various Jerry planes that fly above us, makes me feel quite drowsy. We just sit and smoke and wait for something which isn't happening. It does not look as if the Germans are at all likely to want to come through this particular spot. Peter's troop reports that German armored vehicles are streaming steadily down the road from Halle to Edingen. Phil sees them on the Ninove road heading west. But none are coming straight at us.

11:00 hrs. A message from Phil. He is attacked by three tanks. We can clearly hear the shooting coming from our left. The loud bark of his Boys anti-tank guns stands out over the clatter of the machine guns. We listen anxiously. Then he reports he has knocked one tank out of action and the two others have turned tail. Three minutes later he speaks again; he has gone up to the destroyed tank and found its three occupants dead.

Peter and Roddick start calling too. They say that the whole countryside is swarming with German tanks, armored cars, and motorcycle scouts moving toward their positions. While Elliot and John are busy talking to them and reporting in turn to our colonel, the line of hills just opposite me fills with clouds of dust. Dark shapes are visible moving along the crest. As if they were conscious of the impending danger, the cattle in the surrounding



German soldiers are milking cows, somewhere in a captured village. (Dever from Black Star.)

fields start to bellow, and their plaintive cries mingle with the crackle of machine-gun fire which is now being directed toward us from across the small valley. We are all ordered to get back to the cars, while Elliot reports this new situation to the colonel.

By noon several men have been wounded and a sergeant killed. One car is badly damaged. The colonel orders withdrawal to Galmaarden, a village back of the Edingen-Ninove road, six miles this side of the Dendre River. Each troop leader is to withdraw as he sees fit, towards the squadron rendezvous at Galmaarden.

My car is hidden from the enemy by a high wall. I stand on a large stone and peer over it. I can see four German tanks moving down the road toward the valley which separates us. They are out of range of our antitank rifles, but their machine guns keep pumping bullets into our village. As we are about to leave, Machin and I decide that we should leave a welcoming committee for the invaders. So we go to the stables where we had seen a very large and fierce bull tied up in a pen and we let him loose. He snorts and rushes on the road, while we jump into the staff car and speed off behind the first armored car as it swings left into a sunken dirt road which should lead us away from this village, unseen by the enemy.

13:00 hrs. We have been driving across fields and on dirt tracks, raising thick clouds of dust which must be visible for miles. There is a steady roar of bomber engines above our heads. I don't dare look up as I know too well what is about to happen, and I just decide to start filling my pipe for something to think about when the brakes are slammed, a bright orange flame blinds me, and a number of earbreaking explosions rock the car and knock me into the dash board. Acrid smoke and clouds of dust choke me for a few seconds, then I leap out of the car as if pushed by a spring. The armored car which was ten yards ahead is on its side in a deep gully. Elliot

comes running up and calmly orders all hands to get busy and try to pull the car out of its perilous position.

For five minutes we dig and push while another car skids and tugs at its marooned companion. Just as we are about to succeed, the driver makes a wrong move and it falls back into a deeper hole. Our work is made all the more difficult by the machine gunning that the two bombers are giving us. My shirt and tunic are soaked with perspiration caused by heat and fright when Elliott calls the whole thing off. The equipment is removed from the car and the major reluctantly gives the order to blow it up.

Our arrival at Galmaarden frightens two civilians who are looting an abandoned brewery. A wheelbarrow filled with bottles of beer stands on the road, so I promptly distribute them to our thirsty crews, keeping some for the staff car and the troop leaders.

Phil's and Peter's troops are waiting for us. One of their cars has a large anti-tank bullet hole in it. They are all enjoying my beer when young Roddick's troop draws up under the thick green trees along the road leading from the village. Our faces are yellow with dust and sweat, but Roddick beats us all; his hair and eyebrows are so covered with white dust that he appears to be made up for the part of an old man in a college play.

We all sit down in the roadside ditch while Elliott explains the new position which he has just received from the colonel. The squadron is to spread out in a line stretching between Viane at the northern end to a point south of the Bois de Lessines on the Edingen-Ath road. We have to get across the Edingen-Geraardsbergen road before the enemy gets there, and according to the latest information they are hard on our heels and have already gone through Edingen.

15:00 hrs. We have just crossed over the road, and are being shot at from all angles. Elliott calls me to his car and asks me to take the staff car and the fighting lorry out of the way a bit, west of the Lessines Wood. He sends an armored car to accompany me.

We halt under some thick trees at the northwestern corner of the Lessines Wood and I report my position to squadron HQ. At least twenty bombers roar over, flying very low, and a few minutes later I hear the crashing of their bombs about two miles to the west. They are after the Lessines bridge. There is steady and heavy firing on my right. The German tanks and motorcycle troops are attempting to reach Lessines by the main road which comes from Edingen and Gislenghien. Peter and his troop are guarding it to the north, while a squadron of the East Riding Yorkshire Yeomanry straddles it a mile east of Gislenghien. This cavalry unit is motorized and equipped with light tanks. Their French liaison officer is my friend Philippe de Croisset; he is patrolling the road in an armored Bren carrier, sends me his greetings through Peter, and hurries on towards the village of Silly, south of the road, where most of the shooting is taking place.

Three anti-tank guns are sent up from Ath to help our tanks and armored cars. Unfortunately they set up their position back of us and fire at the British tanks, mistaking them for Jerries. Three light tanks of the Yorkshire Yeomanry are blasted and their occupants killed before one can stop them! They are ordered back to Ath. The big black bombers are still busy over Lessines. Dozens of them, in an unending stream, fly over me and drop their high explosives about the small town through which I will have to pass shortly, *if* they leave the bridge intact. Black smoke and hot ashes blown over us by the westerly wind make the sky look grey and hide the sun.

The pressure on our squadron is getting worse. The enemy is attacking from all sides and our troops are hard pressed. Gislenghien has just fallen, and German motorcyclists followed by tanks are moving on to Ollignies and Lessines to cut us off from the rear. Our squadron has been cut off from the Yorkshire Yeomanry light tank squadron who are retreating towards Ath and putting up a stiff resistance. Elliott asks me to go to Deux-Acren, two miles north of Lessines, and make sure of the bridge there. His orders are to stay on this side of the river till 20:00 hrs. if possible, then to retreat over the Deux-Acren bridge.

19:00 hrs. I have just crossed the railroad and the bridge over the Dendre River west of the deserted, wrecked, and still smoking village of Deux-Acren; we are now on high ground and have a very good view of the surrounding country. I can see the houses burning in Lessines, and to the north the valley of the Dendre for a long distance.

Crossing the main road, I post a motorcyclist to watch for the squadron and drive a few hundred yards down a dirt road to a small farm, where I find some sheds under which our cars can be hidden from the air.

An hour goes by, then orders arrive. The squadron is crossing the Dendre, and I am to go ahead to Buissenal, about ten miles west of Ath, where we are to get food and perhaps a few hours' sleep.

I indicate the position of the village on the map to the driver and we leave at once, driving towards the dense black smoke which covers the flaming town of Lessines that we must pass to reach the road to Buissenal.

We tear down the highway at full speed without stopping, skirting huge craters, dodging burning trucks, charred bodies, and crumbling walls, and finally safely stopping at the hill west of the town, heading for Buissenal.

Lieutenant H., who commands our B (Transport) Echelon, greets me at the entrance of the tiny hamlet which is filled with hundreds of frantic refugees. He has had a difficult time finding billets for the squadron. The armored cars and transport lorries will have to spend the night under the trees of an orchard. He leads me to the farmhouse where the cooks are busy preparing supper, and advises me to rest a bit until the major arrives

with the troops. As we reach the farm, Lieutenant B. and his No. 1 Troop come roaring up the village road. Bleary-eyed, gray faced and filthy with dust and grime, the men scramble out.

I feel very tired and in a sort of daze as I enter the noisy kitchen of the farmhouse. T., our mess corporal, pushes a wooden stool under me; I flop down on it, close my eyes, and fall asleep immediately.

23:00 hrs. The major's voice giving orders to the squadron arouses me. We leave at 3 AM, returning to the Dendre River to try to hold the heights above Lessines, while our infantry withdraws.

There isn't an unoccupied square foot of flooring anywhere in the house on which to lie down and sleep, so I roll up in my blanket under a pile of hay in the orchard.

(To be continued)

Racially, there exists no relationship between the people of Japan and of the United States. And the perverse reluctance of man to forget his own tribal gods and fetishes postpones to such a remote time the assimilation of these two nations that it cannot now be considered. The ethical and sociological conditions extant in Japan, while antithetic to those existent in the United States, are nevertheless the product of two thousand years of Japanese development. To remake the Japanese racial character in order to conform with that of the Occident would require, even were it possible, a longer period of time than we can conceive. Such a racial change in Japan can no more take place than could the West alter its civilization to conform with that of the Orient. Both civilizations will, in due time, by natural but slow process, become so modified that it will be difficult to distinguish the outward forms of one from the other; but racial distinctions and antipathies will continue to remain even unto an unknown time.

No national ideals could be more antithetic than are the ethical and civic ideals of Japan to those existent in this Republic. One nation is a militant paternalism, where aught that belongs to man is first for the use of the state; the other an individualistic emporium where aught that belongs to man is for sale. In one is the complete subordination of the individual, in the other his supremacy.

When national religions differ, racial difference creates antagonism. Thus the Japanese, with their sword-girded gods and militant bonzes, are heathen in the eyes of this Republic, heathen in all the contemptuous, naked inferiority that that term in a Christian nation implies. This feeling will never decrease except with the deterioration of Christianity, since such a decadence is, as far as the Japanese are concerned, more probable than the Christianization of their country.

LEA, *The Valor of Ignorance*.

TANK ATTACK DOWN A ROAD

By Lieutenant Colonel N. W. Jones, FA

A study of recent tank operation indicates that in many situations Armored Forces will be forced by nature of the terrain to advance along roads with very little possibility of maneuver. Tacticians will say that this is unfavorable tank terrain; but are we going to accept the fact that armored units cannot be used simply because rapid and wide flanking movement cannot be made? Such an attitude will lose any war. An enemy worthy of the name will defend himself by organizing his defense on ground unfavorable to tank action. This means that armored forces will be obliged to fight on unfavorable ground and under unfavorable conditions, or they are not going to fight.

Suppose a tank column is ordered to attack along a road known to be defended by numerous anti-tank guns, and no maneuver is possible because of the nature of the terrain. This is a hard nut to crack, so let's examine the situation. When a large force is making a penetration, the attack is generally preceded by as much artillery fire as can be massed on its front. The fire is not lifted until the attacking infantry is within assault distance of the enemy positions. If this is good tactics with a large force, why not also with a small one? We are unable to maneuver but we can *shoot*, so let us base our attack on a combination of artillery fire and assault. U. S. tanks will withstand small arms fire at any range and antitank gun fire above certain ranges; however, it is not considered good



This Jap tankette M2595 (1935) failed to get down the road. Hampered by the road-block, it was destroyed before it could effectively use the 37-mm. turret gun or its machine guns. Its riveted armor, about 1/2-inch thick, was quite insufficient. The block prevented use of its 22 m.p.h. speed. (Acme photo)



An incautious Jap tank-attack down a road loses three tanks, after they are slowed by hasty block visible above the gun-shield. Note the gun's base-plate for quick all-around fire; the sight projecting above the shield; and the observation ladder at left. The shield appears to be amply large, but thin. (Acme photo)

practice to expose tanks to anti-tank gun fire if it can be avoided.

This can be accomplished by intelligent observation of the road along which the advance is being made. The following is suggested: (1) map study, locating likely points of anti-tank gun positions; (2) airplane reconnaissance of the road to spot such targets as can be thus located; (3) cautious advance from one point of observation to another, with the leading section always being supported by a platoon in firing position out of effective anti-tank gun range. This is simple to say but hard to execute. However, it frequently will be possible. The commander of the leading tank platoon should advance his platoon from one point of observation to another. Tanks should not break cover or defilade until a thorough study of the terrain along the road has been made by the platoon commander using his field glasses and preferably dismounted. He should be accompanied at this time by an artillery observer.

For illustration, let us consider a simple situation. Combat Team I of the 6th Armored Division is advancing along a road defended by anti-tank guns. The 1st Battalion, 70th Armored Regiment, is in the advance guard, supported by 39th Field Artillery Battalion, Armored, (less Headquarters Battery, Service Battery, Battery C, and Combat Train). Company A is in the lead followed by Batteries A and B, one of which is in position



Combat occurs suddenly, like the fight pictured here, where a German infantry cannon has instantly gone into action against the Soviet armored vehicle just visible up the road through the trees.

to fire at all times. Artillery has priority on roads. Lieutenant Ducrot, commanding the 1st Platoon, Company A, is leading the advance. He is accompanied by artillery observers from both batteries. As his platoon approaches Crest A, he signals his platoon to take cover. Dismounting from his tank, he goes on foot to a point from which he can observe along the road. With his field glasses he studies the terrain, and after some time spots an anti-tank gun in position at about 500 yards. He signals an artillery observer to join him, points out the target, and requests that it be neutralized. By means of radio communication, the forward observer places quick and accurate fire on the anti-tank gun. The sheaf is converged and a single range used for fire for effect. During this time Lieutenant Ducrot has ordered his platoon forward to assault positions. When fire

for effect is started the artillery observer signals Lieutenant Ducrot to attack; the artillery fire is not lifted until the tanks have approached very close to the anti-tank gun position, when Lieutenant Ducrot signals to "lift Fire."

It must be realized that tanks can approach very close to the point of impact of artillery projectiles without danger of injury, when the artillery fire is controlled by an observer. If other anti-tank guns are suspected of being in support of the one under fire they can be blinded by a few rounds of smoke just before the tanks move forward. If they divulge their position by firing, the artillery observer should shift his fire to these new targets when the signal to "Lift Fire" is received from the tanks.

The above procedure will have to be repeated every little while, but it is "a solution."

A PET PEEVE

Fifth columnist is used too generally. It is soft-soapy, ducks the issue, causes muddy thinking. Better use one of two short, direct, well-known words which will always fit: *spy* or *traitor*.



Life

AUTHOR'S NOTE: This article is an attempt to estimate German casualties in the Russian campaign to December 8, when the Reichswehr passed from the offensive to the defensive. All the material used in the preparation of the article was drawn from published sources. Despite the paucity of information available, it is hoped that some of the results obtained may prove of value. In a few instances, findings are included which do not appear directly profitable but which are possibly suggestive.

The Germans have announced their total casualties in the Russian campaign only twice: once for the period from June 22, 1941, to August 31, and secondly, for the whole war from June 22 to December 1. Not knowing the correct figures, we cannot definitely prove that these are incorrect. However, it can be shown that there is a strong presumption that these figures are wrong.

THE GERMANS' FIGURES

According to the figures covering the full period to December 1, the average casualty rate in Russia was 4,775 per day. Germany had announced previously its casualties in the Battle of France, in which casualties were low enough and the victory great enough to permit the conclusion that the announced figures probably were accurate. In this campaign, from June 5 to June 24 the daily casualty rate averaged 4,813—greater than that now announced as the rate in Russia. This is manifestly absurd. In the Battle of France, the Germans were opposed by a force of not more than 65 divisions, which already felt whipped. They had command of the air and crushing superiority in equipment, fighting ability, and morale. As opposed to this, in Russia they have encountered a force several times larger than the French army, much better equipped, much better led, and fighting with unbreakable morale. The announced figures must therefore be regarded as inaccurate.

If we assume that the German statement of their casualties is a fabrication, it is likely that the figures were built up on some logical basis. We will not know definitely until after the war how this was done, but we can make some plausible deductions even now.

German Casualties in Russia

By Lieutenant

Andrew M. Kamarck, FA

Their first casualty figures for the Russian campaign were not issued until September 19, although the Russians already had announced their casualties to August 22. The Germans announced that they had captured 1,800,000 Russian prisoners to August 31 and that the number of dead Russians was at least as high. If one takes a conservative estimate of two wounded for every man killed, according to the German figures the Russian casualties must have amounted to at least 7 million. Now, even if the Germans sincerely believed that the Russians had sustained 7 million casualties, they would not have announced their own true casualties if these were higher than the casualties the Russians had announced for the Russian army. A propagandist as astute and unscrupulous as Hitler would reason, "The Russians announce they have 700,000 casualties. We know they have had more. But if we announce our casualties as, say, 800,000, most people are just stupid enough to believe both us and the Russians. For these people, we must announce our casualties as lower than the Russian figures of their casualties."

If one places himself in the position of the Nazi who had the job of concocting the casualty figures to be issued, he can imagine his thoughts running somewhat as follows: "We are being taunted with having suffered huge losses. The Russians have admitted casualties of 700,000, so we must announce casualties a great deal less. How much less? A convenient fraction would be one-half. According to the Russian figures, they have been experiencing casualties averaging 11,500 per day. The figures to be announced as our casualties must be, therefore, at a rate of 5,750 per day."

No sooner said than done. At a rate of 5,750 per day for the seventy days to August 31, total German casualties would come to 402,500. The actual total announced by the German High Command for this period was 402,960. As far as the breakdown between dead, wounded, and missing is concerned, the actual ratios experienced in the campaign could be applied, or the experience of earlier campaigns could be used. It might be noted that the ratio between dead and wounded in the figures announced, 1 to 3.5, coincides with the ratio of dead and

wounded in the German casualty table summing up the experience of all the preceding campaigns of the war.

Germany did not issue any more figures until December, when Hitler stated that the total casualties to December 1 amounted to 773,515. Is it possible to figure out how these figures were derived?

First of all, the Germans did not continue to use the daily casualty rate of 5,750 used in September. For the period from June 22 to December 1, a rate of 5,750 would have resulted in a total casualty figure of 930,000. This may have been regarded as too high. The Russians had issued their own figures to November 22, giving them a casualty rate of 13,900 a day. If the method of taking a rate which was half of the Russian rate had been used, this would have given the Germans total casualties of 1,126,000 to December 1. Again, this may have been rejected as too high. Germany may have simply adopted the rough casualty rate it experienced in the Battle of France, i.e., 4,800 a day. At this rate, it would have had 777,600 casualties to December 1. The figure that was issued was 773,515 (if one uses 161 days, rather than 162 days, the total, at a rate of 4,800 a day, becomes 772,800).

Another possible procedure also uses Russian figures as a starting point. The Russians, when they announced their own casualties to November 22, also announced their estimate of the German casualties as being 2.8 times greater than the Russian casualties. In concocting his figures, the German concerned may simply have argued that he would follow suit and make the Russian figure of Russian casualties that many times greater than the German figures of German casualties, and gild the lily a bit by raising the Russians by one-tenth. In any case, the ratio works out that after the Russians published their figures and then Hitler issued his: the German figures of Russian casualties are 2.9 times greater than the German figures of German casualties, while the Russian figures of German casualties are 2.8 times Russian figures of Russian casualties. This relationship may or may not be significant, but it is certainly curious.

One method of estimating German casualties in the Russian campaign would be to use the experience of preceding campaigns. The Russian war is practically unique in the experience of the present German army. The so-called Weygand Line, so far as can be ascertained, was the only attempt made by any of Germany's opponents, before the Russian campaign, to meet the threat of armored forces by organizing a position in depth for antitank defense. The job was not well done: the French had only a few days to prepare their defense in depth, very little antitank armament was available, tank forces were insufficient for counterattacks, the army's morale was crumbling, and air support was lacking. After five days of hard fighting, from June 5 to June 10, 1940, the Germans broke through the Weygand Line, and after that the operations were mainly the pursuit of a beaten enemy, although some hard fighting did take place.

The Germans had fought two previous campaigns somewhat similar to the fighting that took place from June 10 to June 25. These were the Campaign in Poland and the Battle of Flanders, May 10 to June 4. In both of these the results were similar: German casualties averaged 2,460 per day in Poland and 2,500 per day in Flanders.

We might, then, assume that the German casualties from June 10 to June 25 averaged 2,500 per day. Since casualties averaged 4,800 per day for the entire French campaign, German casualties from June 5 to June 10 must therefore have averaged 11,750 per day. That is to say, German casualties in the Battle of France, when conditions bore most resemblance to those on the Russian front, were roughly 12,000 a day. Considering the greater number of German troops used in Russia, the greater number of Russian troops encountered compared to the French, the fiercer fighting in Russia, and the superior equipment, training and morale of the Russians, it would seem safe to say that the casualty rate in Russia has been much greater than that experienced in the opening days of the Battle of France, and that German casualties in Russia must have averaged at least 12,000 a day, making a total of 2,000,000 to December 8. The actual total may well have been considerably higher.

DEDUCTIONS FROM RUSSIA'S ADMITTED LOSSES

Another approach to securing an estimate of German casualties would be to start from the Russian figures of their own casualties.

The Russians state that their casualties to November 22, after five months of war, totalled 2,122,000, or a rate of 14,000 a day. If this rate continued to the end of the German offensive on December 8, total Russian casualties would have been 2,370,000. For a true appreciation of the magnitude of these casualties, it is only necessary to observe that the total is 600,000 larger than the size of the whole army of the United States at that date.

It has been suggested that the Russians must be convinced that the German casualties are higher than the figures they are giving of their own losses, otherwise the Russians would be providing the enemy with valuable information on their own weakness. There is considerable merit to this idea, and this argument justifies use of the Russian casualty figures as one estimate of German casualties.

Russian casualty figures might be taken as a measure of German casualties in still another sense. From the descriptions of the Russo-German War reaching this country, it is obvious that the Germans were constantly running up against Russian prepared positions—either temporary or permanent works. The Russians fought for and in every important city. They laid antitank traps, mined roads, prepared booby-traps, sprang ambushes, and used every device of defensive warfare open to them.



The German dual-purpose MG-34 is rapidly replacing all other machine guns. For ground fire, it uses an extremely flexible metal belt of 10 strips, each holding 25 cartridges. These strips are disconnected when the cartridge joining them is fired. Caliber: 7.9-mm. Maximum range: on bipod, 2,200 yards; on tripod and using telescopic sight, 3,800 yards. Weight without mount: 15½ pounds. (Dever from Black Star.)

It seems fair to assume that the advantages of the defense were exploited by the Russians to the fullest, and that the price had to be paid. Based on the previous campaigns of the Germans, when they were able to win a complete victory over grossly inferior foes, there is a tendency unconsciously to swing to the opposite extreme from the Liddell Hart glorification of the advantages of the defensive and to assume that the defensive is necessarily more costly than the offensive. This is, of course, a manifest absurdity, if given as a general rule. So far as can be learned, the strategy of the Russians up to December 8 was to bleed the enemy by selling space to him. The Germans countered this by attempting to cut out sections of the front by constant encirclements and so destroy the Russian army piecemeal. The Russian active defense policy attempted to offset this policy by counterattacks. On balance, it is difficult to gauge which side would necessarily suffer the most casualties. The advantages the Germans gained by advancing and collecting their wounded and stragglers were offset to some extent by the losses experienced from ambushes and storming

prepared positions. Under these circumstances, where neither side has yet won a decisive victory over the other, casualties on both sides may have approached equality. Such a condition occurred in some of the last battles of the First World War.

The Russians gave out their casualty figures fairly frequently for the first five months of the war. Analysis shows that they averaged 14,000 casualties per day. In the first weeks of the great German offensive which began on October 2, the rate rose to 40,000 per day. The Russian figures appear to be, on the whole, internally consistent. Their rates appear to rise in periods of great battles and sink during relatively quiet periods. For example, in the second two weeks in August, the Russian casualty rate, by derivation, is seen to be 7,000 a day. This is to be contrasted to the 40,000 a day in October.

The Russians have a higher ratio of dead to wounded than the Germans do according to their figures. The Russians state that they have one man killed for every 2.6 men wounded. The German rate was one man killed for every 3.5 wounded in all the campaigns up to the Russian venture, and figures of their casualties in Russia up to August 31 maintained the same ratio; from August 31 to December 1, however, it was 1:3.7, the same ratio that was developed in the Battle of France. The higher Russian ratio of killed soldiers might be due to their mode of fighting. All the German accounts emphasize that the encircled Russian soldiers seldom surrender but fight until killed. Since the Russians were generally retreating to December 8, the wounded who were not evacuated either died fighting or were taken prisoner and became "missing."

FANTASY MAY BE FACT

There is one derivation of German casualties which seems fantastic, but which might still be of value. In this war, the absurd has so often become the actual (for example, the flight of Hess to England) that even the fantastic must be considered. That is, somebody who had a hand in concocting the published casualty figures may have slipped in a clue which would help those on the outside to un-concoct them.

There is one number in the casualty tabulation issued by the Nazis which may provide this clue: the number of soldiers missing to December 1 was announced as 33,334. This number clearly suggests that the figures given are a third of the correct total, or that the correct casualties are three times as great as the ones published. If this is true, it would make the correct German casualties to December 8 total 2,370,000 or an average of 14,000 per day—an estimate which agrees very well with the preceding two.

This idea that someone connected with the creation of the figures wished to betray the secret may not be wholly erroneous if a number of circumstances are remembered. First, in spite of the facade of complete unity, there are undoubtedly numerous Germans opposed to Hitler; one needs only to remember that the Nazis were never able

to win a majority of votes at a free election. Opposition to the Nazis in the army is not unknown. The murder of General von Schleicher, the German Chancellor preceding Hitler, in the Nazi blood-purge of June 30, 1934, scarcely needs to be cited. Have General von Schleicher's friends in the army completely forgotten and forgiven? The death in front of Warsaw of Colonel-General von Fritsch, commander-in-chief of the German army in 1938, may or may not be a part of this pattern.

Then there is the naval communique of December, 1939, on the suicide of the captain of the *Graf Spee* in a hotel room in Buenos Aires, cited by Shirer: "The High Command of the Navy announces: The Commander of the *Graf Spee*, Captain Hans Langsdorff, did not want to survive the sinking of his ship. . . . Having brought his crew to safety he considered his duty fulfilled, and followed his ship. The navy understands and praises this step. Captain Langsdorff has in this way fulfilled like a fighter and a hero the expectations of his Fuhrer, the German people, and the navy." As Shirer points out, the author of the communique does his best to hint that Captain Langsdorff killed himself because of direct orders to do so.

THE RUSSIAN ESTIMATES

In the course of the campaign the Russians have, from time to time, issued their own estimates of German casualties. In analyzing these estimates, we find the following casualty rates used for different periods.

<i>Period</i>	<i>Casualty rate per day</i>
June 22 - July 5	54,000
July 6 - July 13	38,000
July 14 - August 22	25,000
August 23 - September 24	9,000
September 25 - October 5	64,000
October 6 - November 6	42,000
November 7 - November 22	94,000
Arithmetic Average—	
June 22 - November 22	38,000
Median—June 22 - November 22	42,000

After the initial impact of the invasion, by July 14, it will be noted the Russians seem to have settled on an estimate of 25,000 casualties per day. The derived figure of 9,000 casualties per day in the period August 23 to September 24 may have resulted from the Russians correcting their too high estimates for the first weeks of the invasion. This might be inferred from the fact that the Russian estimate of total German casualties for the war up to September 24 gave a daily average of 25,000 a day.

On October 2, the great German offensive directed against the Donets and Moscow began. Under the emotional impact of this danger, Russian published estimates of German casualties increased after October 2, compared to the preceding months. In view of the fierce fighting before that date, when both armies were comparatively much stronger, it is probably not likely that casualties increased as much as the figures indicate (i.e., from 25,000 per day for

the period before September 24 to 60,000 per day during the next two months). It is to be noted, also, that the latest Russian figures available for the campaign to December 8 are those of Russian journalists and not of the army spokesman. From this reasoning, one might recognize the true Russian estimate to be 25,000 per day, rather than the 38,000 per day that is derived from the final Russian figures.

At a rate of 25,000 per day, German total casualties to December 8 would have amounted to over 4,000,000 men. Since the total German army is estimated to number 7,500,000 in ground troops and another 1,000,000 in the air force, the objection might be made that any casualties above 3,000,000 would be incommensurate with the effort made by the German army. This may well be so. Nevertheless, it seems that there are certain considerations which might modify this judgment. In the first place, there is the unquestioned fact that the Germans have accomplished a number of things which had earlier been deemed to be most improbable. The sweeping victories the Germans won, there is reason to believe, were even beyond German expectations.* In view of the ability shown by the Germans to solve the difficulties of transport to the Eastern Front, they might likewise have the ability to keep their army going even under the impact of such large casualties.

In the First World War, France suffered 6,200,000 casualties or 73 per cent of her total mobilized forces. Sixty-five per cent of the total mobilized German forces were casualties, and 76 per cent of the Russian army. If the figure based on the Russian estimate of 25,000 German casualties a day were accurate, Germany up to December 8 would have suffered casualties which were somewhat less than 50 per cent of her total mobilized forces, or much less than the losses suffered in the First World War, which did not prevent the German army in 1918 from mounting the biggest offensive of the whole war.

If one, in addition, considers that more than three-fourths of the casualties are wounded, who may return to duty, the credibility of the 25,000 rate is further enhanced. In the last war, according to Colonel Ayres in *The War with Germany*, five-sixths of the wounded in the American army were cured and returned to duty. The progress in medicine since 1918, particularly in the field of anti-tetanus prevention and in blood transfusion techniques, should result in an even higher proportion of complete cures.

Still, it is quite probable that the Russian figures may

*Note, for example, the revealing remarks of General Metzsch. "One could have guessed that the fifty-odd Polish divisions would be so wretchedly led; but it was not to be expected. To dare to occupy the Norwegian coast under the guns of the superior British navy was a leap in the dark. No one could be quite certain that it was possible, within a few days, to penetrate into the heart of Netherlands fortifications, against the obstacles in the country. Even in Belgium, a stronger defense was thinkable than was actually offered at certain points. The most modern border fortifications were reduced in a matter of hours. In France, finally, the inferiority of the enemy fell to almost fantastic proportions." (*Rheinisch-Westfälische Zeitung*, September 1, 1940. Quoted in Max Werner, *Battle for the World*, p. 228.)



Street fighting is expensive. (Dever from Black Star.)

represent over-estimates of German casualties. One reason is obviously the desire to make propaganda capital in the Axis and occupied countries. Also, even though the Russians are in a better position than any of the United Nations to make an estimate of German losses, it is still quite true that prior to their recent advances even the Russian estimates could be scarcely more than educated guesses. The Russians were almost constantly forced to give up territory and did not have the check on their estimates that gaining the battlefield affords. Casualties caused by the extensive Soviet mining of abandoned positions and towns could only be guessed at; that these were fairly large can be inferred from the German rage, several times publicly expressed, at this practice. The Germans did announce the death of one general, Major-General Braun, by a Soviet mine on December 1, but they have not been cooperative enough to give the complete total of their casualties due to this cause.

Another drawback to the Russian figures is that they may have been influenced by the natural psychological tendency to overestimate the losses which one has inflicted on the enemy. The submarine sinkings of shipping in the last World War provide a similar situation, where accurate knowledge of the losses was vitally necessary to know how a decisive struggle was progressing. The German figures over-stated actual British losses considerably, but the Germans honestly and sincerely believed their figures were correct and bitterly accused the British of deliberately lying. On the other side, the published British figures were accurate, but since coastal and overseas traffic were lumped together, they gave the misleading impression that losses were much lower than they actually were (as is

clearly pointed out by Sir Arthur Salter, in his book, *the Allied Shipping Control*).

In studying the various Russian casualty figures, we find that after the first estimate there is a fairly uniform ratio between Russian and German losses. According to the first Russian estimate, they were putting out of action four Germans for every Russian. Thereafter, however, all the figures giving total German and total Russian casualties since the beginning of the war maintain a fairly consistent ratio of one Russian to every 2.8 Germans. The detailed table follows:

RATIO BETWEEN TOTAL RUSSIAN CASUALTIES AND TOTAL GERMAN CASUALTIES AT VARIOUS DATES

July 13	1:4
August 2	1:2.8
August 22	1:2.9
October 5	1:2.7
November 22	1:2.8

(Russian source)

There are several possible explanations for the consistency of the ratio used. It may be that the Russians, based on experience, believe they are inflicting 2.8 casualties for every one they suffer, and therefore compute figures for German casualties based on their own. Such a relationship cannot be set aside as altogether impossible. If one is not dazzled by the results of the decisive German victories in the west and reverts to the experience of the last war, one can find numerous examples of this. Churchill, for example, points out that "The Anglo-French offensives of 1915, 1916, and 1917 were in nearly every instance, and certainly in the aggregate, far more costly to the attack than to the German defense. It was not even a case of exchanging a life for a life. Two, and even three, British or French lives were repeatedly paid for the killing of one enemy. . . ." (*The World Crisis*, Vol. 2, p. 4.) The German comment that the Russians utilized the ground defense "in a manner that was most effective" is to be recalled in this connection.

Another possible reason for the uniformity of the ratio is that it actually exists and that Russian methods of estimating German casualties *independent of their own casualty figures* are accurate enough to show final results which demonstrate the ratio.

A third possibility is that the Russians are merely fabricating

the German casualty figures and using their own casualty figures as a basis with a multiplier of 2.8.

GENERALS AS YARDSTICKS

One possible method of estimating German casualties might be to base the estimate on the number of generals killed, since we have more data available on the deaths of these gentry than on the deaths of privates. There are several drawbacks to this method. In the first place, it has been pointed out by the British magazine *Aeroplane* that the Germans often deliberately withhold the news of the loss of officers: the deaths of some German officers in the Norwegian campaign were not made public for a year and a half. Secondly, American newspapers, which were used as the source, may not report a German announcement of the loss of a general officer. In November, for instance, the *New York Times* carried a story of the death in action of General von Briesen; his death was news because, the account stated, he was the fifth general killed in Russia whose death had been announced during the preceding two weeks' period. The deaths of the preceding four had not been individually reported, however; in short, the death of a single general was not news. There is also the difficulty that a casualty due to the war may be reported as a natural death, or as due to an accident in Germany. Is it a mere coincidence that the deaths of some of the most prominent German military personnel have nearly all occurred during the Russian war—but were not caused by the war? Colonel General Ernst Udet died in an accident in November; Colonel Werner Moelders, Germany's most successful air ace, was killed in another accident in November; Field Marshal General Walther von Reichenau died of apoplexy in January; near the first of February, Major General Hans Georg Hofmann died of a heart attack; on February 8, Major General Fritz Todt, Reich Minister for Armament and Ammunition, was killed in an airplane crash "while carrying out an official mission to the East." Finally, the assumption that casualties among generals are representative of the whole army is a dubious one. In surveying the objections to this mode of procedure, it is obvious that all of the above points would give a downward bias to the results. Therefore, the casualty estimate derived in this way must be regarded as considerably understating actual casualties.

According to the information available, the Germans have announced the death of five specific division commanders. Lieutenant General Arthur Muelverstedt, Major General Kurt Kalmukoff, Major General Ritter von Webber, and Major General Otto Lancelle, all commanders of divisions, were killed during the summer. The death in action of Lieutenant General Frederick Bergmann, commander of an infantry division, was announced in December. There were also seven other generals killed whose command was unspecified. Lieutenant General Joseph Leopold was killed during the summer. General Kurt von Briesen (commander of an army corps in France)



An infantry 75-mm. howitzer is being brought into position. This particular weapon is part of the motorized rifle brigade of a Panzer Division, as indicated by its rubber tires for towing behind a truck. The normal infantry howitzers are not so provided, as they are designed to be drawn by horses. A light tank appears in the right background. The motorcycle with sidecar is furnished for messenger service in all units. (Signal Corps photo.)

was killed in action on November 20, 1941, on the Eastern Front. The deaths of four other generals announced around this time were not specifically reported. On December 1, Major General Braun was killed by a Soviet mine. In early September, Colonel General Ritter von Schobert, commander of the German-Rumanian Moldau Army, was killed in action. The latest death in action of a general included in the foregoing list occurred on December 1.

From examination of the information available on each of the generals listed, one can assume that it is probable that they were divisional commanders or higher-ranking officers. The assumption that they were all divisional commanders would create a downward, rather than an upward bias, as one can fairly assume that the chances of death of a corps commander or an army commander would be smaller than those of a division commander.

On this assumption, the Germans suffered the loss of 13 division commanders killed on the Russian front to December 1. Using the German ratio of 1 killed to 3.6 wounded and 1 missing to every 5 killed, this would mean that the casualties among German division commanders totaled 62. If casualties of division generals represented a fair sample of the casualties of all ranks and if the foregoing were a complete list of all the German generals killed on the Russian front, figuring a division as 15,000 men, German casualties to December 8 would have totalled 930,000 men. Nearly all the objections to the procedure of using the casualties among generals as a method of estimating total German casualties are such as to give a downward bias to the final results. Under the circumstances, one can assume that the estimate derived gives only a partial total of German casualties.

While the results are not significant in giving a complete total of German casualties, it is interesting to note that the partial total secured by this method is still considerably above the German figure of 774,000.

SATELLITES' STATISTICS

There is still another approach to the estimation of German casualty figures and that is to work with the casualty figures of the German satellite nations. Only Rumania has issued any usable figures. Early in the autumn, the Rumanian Government made an announcement of their casualties in the war to October 6. In view of the uncertain political situation in the country, the government had very strong reasons to understate its casualties. There are grounds for believing that casualties may have been considerably higher than the figures announced. As one indication of the punishment taken by this army, even its Chief of Staff, General Jonescuc, was killed.

According to its government, the Rumanian army suffered 111,000 casualties up to October 6. So far as it is possible to estimate, that army in Russia totalled 18 divisions, or at 20,000 men to a division, a first-line strength of 360,000 men. The 111,000 casualties represent, therefore, a little more than 30 per cent of the first-line strength.

The Rumanian soldiers, not being so good as the Germans, would for this reason, all other things being equal, have greater casualties than the Germans would. On the other hand, comparable German forces did considerably more fighting and more of the harder fighting in a given period of time than the Rumanians did. On balance, it would seem that the Rumanian losses would be proportionately less than the German losses. However, to

be on the conservative side, it is assumed that the Rumanian casualties are representative of the German army.

The Germans are estimated to have used about 180 divisions in the Russian campaign. Since they are believed to have had 300 divisions at the start of the campaign, they could maintain this force easily as far as considerations of numerical strength available go. At 15,000 men per division, the total number of German combatants involved in the Russian campaign at one time would be around 2,700,000 combatants. Using the Rumanian rate of 30 per cent casualties up to October 6, the Germans would have experienced 810,000 casualties—a rate of 7,640 per day. Since the Germans began a new drive on October 2, reinforcements would have kept the German army at least at the level of 180 divisions. Carrying forward the 7,640 rate to December 8, based on these figures the Germans would have suffered 1,240,000 casualties. It is to be noted that this total is fifty per cent larger than the official German figures. Since the Rumanian official total is as likely to be as false as the German, the results obtained can be regarded as significant only in demonstrating that the two High Commands are out of step.

In summing up, it would seem that the most likely estimate of German casualties to December 8 is 2,000,000 to 2,400,000, or a rate of 12,000 to 14,000 per day.

EDITOR'S NOTE: The press announced on April 1st that the Germans were sending 100 fresh divisions to Russia to start the spring offensive. At 15,000 per division, that makes 1,500,000 men. If you add to this the necessary corps troops you again get from 2,000,000 to 2,400,000 men, which is another way of arriving at the total German casualties. This assumes that the 100 new divisions are to replace last year's losses.

MAKE 'EM PAY

"Any person subject to military law who willfully, or through neglect, suffers to be lost, spoiled, damaged, or wrongfully disposed, any military property . . . shall make good the loss or damage . . ." and be court-martialed.—The 83d Article of War.

"If any article of public property is lost or damaged through the fault or neglect of any officer or enlisted man, he will be required to pay the value thereof . . ."—AR 35-6640.

Boy, Oh Boy! Have we discovered how to keep this man's army full of drivers and mechanics and motor officers for the next five thousand years. No more recruiting, no more enlisting, no more drafting—just make 'em pay for the engines they burn out for lack of lube, make 'em pay for the tires they ruin by underinflation, make 'em pay for the front ends they smash up because they didn't see that stump in the road, make 'em pay for the tailgates they splinter because they didn't look where they were backing, make 'em pay for the heads they crack because they didn't keep the cooling system full . . . Make 'em pay . . . pay . . . pay . . . pay . . .

If the Preventive Maintenance failures keep on pouring into the shops at the present rate, someone is going to get wise to the 83d Article of War and AR 35-6640 and start doing things. If you ever want to get out of the army, brother, start thinking about PM—and think fast.

—Army Motors.

They both . . .



JEEP ARTILLERY

By Major Charles W. Raymond, 2nd, FA



. . . buck!

After the first cross-country ride in a quarter-ton with an adept driver, one concludes that the "jeep" is the nearest thing to a horse or mule so far invented. These little buggies are already answering that prayer of the dismounted, motorized, old horse-drawn artilleryman as he reconnoitred on foot, "O Lord, give me a horse."

We have seen the quarter-ton rigged up to lay wire, have seen it towing a 37-mm. gun, and have heard some people even wondering if it won't work all right to haul the 75-mm. field howitzer. As to this last, a glance at the jeep's name plate shows, however, that with the trailed load limited to 1,000 pounds, the 75-mm. field howitzer is too much for this small car to handle on anything but good level roads. But why bother about attempting to tow the field howitzer, when we already have its more flexible twin, the 75-mm. pack howitzer? Why not carry the pack howitzer in a pack on a group of quarter-tonners?

The counter question is, "What for?" We will come to that, after outlining a plan for a unit of "pack artillery, motorized." First, though, we would make clear that this is no contention that all pack units substitute the quarter-ton motor vehicle for animals. This is not an argument for substitution, but for adaptation, to be applied to new units in addition to such animal-transported pack artillery as we may see fit to maintain.

THE HOWITZER SECTION

The conventional pack section has six mules for the six break-down loads of the howitzer, and six more mules for ammunition. How many jeeps equal a mule, or vice versa? Let us say that a quarter-ton car is the equivalent of two mules, in load capacity if not in orneryness; six quarter-tons will then be required to replace the dozen mules of the section. We can place two howitzer pack loads on each of three jeeps, and the other three jeeps

can carry the six ammunition mule loads. It is better, however, to place one howitzer pack load on each of the six jeeps, and then load the vehicles up to proper capacity with ammunition. The advantages of this loading arrangement, in case of a vehicle fall-out, can be seen if one considers the time involved in shifting loads. All parts of the piece must be kept moving, whereas a part of the ammunition can be left behind to be brought up later. The portion of the piece on the stalled vehicle can be quickly transferred to any one of the other five vehicles of the section, some of the ammunition being jettisoned if need be.

Here is where some practical experimenting must be done, to devise the best way of packing each of the howitzer loads on its jeep. I did not say "to see if it can be done," for since each of these loads can be placed on a mule-back the possibility of somehow putting it on a jeep can scarcely be questioned. It has probably already been done, somewhere, by someone. Jeep bodies would undoubtedly have to be modified to some extent, but a good metal worker with a welding set, a cutting torch, and a little ingenuity could do the trick.

EQUIPMENT RULES

1. In designing our new unit we will confine ourselves to utilizing the equipment of the same type provided by tables of basic allowances for pack artillery. Such items as radio, wire, cooking and maintenance equipment, and observation and survey instruments, should be of the same kind that now travel by mule. In short, let's not load up, just because we are motorizing, with a lot of fancy ice boxes and millstones that would squash a mule flat on his belly. Keep our paraphernalia portable, by mule, by jeep, or by hand.

2. We will equip our new unit with quarter-ton jeeps, all jeeps, and nothing but jeeps. We'll be hard-headed and unswerving on this point. One moment of weakness, and presto! we'll have a bunch of half-tonners, wreckers, and what-nots in our midst. We must just be obstinate, and have nothing but quarter-ton jeeps—and all will be of the same make and model within the unit.

3. We will have no trailed loads. We're knocking down and packing our shooting irons, so everything else travels the same way. If we haven't enough space for the necessary equipment and personnel, we will add more jeeps to our table of organization until it all comes out even. Any vehicle's mobility is decreased by a towed load, but a jeep can really scramble, back-and-fill, and crawl its way over obstacles when its apron-strings are free.

TABLE OF ORGANIZATION

We will have a battalion. It will have 12 75-mm. pack howitzers, in 3 howitzer batteries; a headquarters battery; and a service and ammunition battery. The T/O of the conventional pack battalion will be our guide.

Dropping from our table all individuals whose duties pertain solely to the handling and maintenance of animals, and adding a number of motor maintenance personnel estimated to be sufficient to care for a large fleet of small identical vehicles, we come out with some approximate figures on organization strengths. Figuring two men to the jeep for such loads as the howitzers and wire reels, four men to the jeep for transportation of personnel overflow, and only a driver for cargo vehicles of the service battery, we arrive at approximate vehicle strengths. Both personnel and vehicle strengths have been slightly rounded out, for the sake of providing a few spares and replacements. It is further assumed that the familiar principle of a full-time driver for each vehicle, as in other motorized artillery, is not applied here. Roughly one-third of the vehicles will have full-time drivers, while the other two-thirds will be operated and cared for by personnel who function primarily along other lines. For example, an instrument sergeant or scout corporal could well be his own driver, and could "groom his own mount." As a corollary of this, one individual can "groom" several other "mounts" besides his own.

The approximate strengths for our battalion run something like this:

<i>Organization</i>	<i>Officers</i>	<i>Enlisted Men</i>	<i>¼-Ton Vehicles</i>
Hq. & Hq. Bty.	10	105	40
Battery A	4	125	50
Battery B	4	125	50
Battery C	4	125	50
Service Battery	5	115	80
Totals	27	595	270

The enlisted strength shown above should be compared to that of the conventional pack artillery battalion. The saving in manpower would go a long way toward offsetting the increase in cost of equipping a battalion with quarter-ton cars, over the cost of providing the number of animals required by an animal-transported battalion. The economy of space for transporting the motorized battalion, both by rail and by ocean vessel, would be considerable.

The attached medical unit is not included in this estimate, but it should conform to the type and size of the combat unit and its equipment. This would be a field for experiment by a medico with ideas: for instance, how to modify a bantam to carry a couple of stretcher patients without hastening their demise.

WHATS, WHYS, AND WHEREFORES

In addition to the basic battalion contemplated above, circumstances might warrant the provision of an antitank and anti-aircraft platoon of about one officer and thirty men, with twelve jeeps of which six would be self-propelled 37-mm. mounts. A further addition in some

cases might be the *attachment* of a motor transport element of larger cargo vehicles such as the 2½ ton truck, with appropriate accompanying personnel. This element should be capable of *immediate detachment* when the opportunity for its employment has passed. This latter addition is not really a violation of our Rule 2, and is in keeping with present practices relating to animal-transported pack artillery.

In general, our aim should be to utilize all of our items of pack artillery equipment as now furnished, for obvious reasons of standardization. Use and adaptation of materiel already in production on a large scale seems to be dictated by ordinary logic. One modification, however, appears desirable: to provide the carriage of the pack howitzer with pneumatic tired wheels on high speed bearings, all interchangeable with those of the jeep. This leads to the one concession to our Rule 3: that, when justified by short hauls on good roads, or for short displacements when speed can be gained thereby, we may trail the assembled howitzer behind a bantam. This would be a necessary expedient, moreover, whenever the mortality of quarter-ton becomes such that we no longer have enough of them left for operations completely packed.

A battalion so constituted would provide the first opportunity for us to see that oft-mentioned but never-materialized motor outfit with just one, uniform, standard type of vehicle. This never was feasible before, because a prime-mover as small as a command car couldn't prime-move, and a reconnaissance vehicle as big as a prime-mover had all the secretiveness and concealment possibilities of Jumbo. Here at last is a vehicle suitable for reconnaissance, for prime-mover (or shall we say "prime-toter"?), for wire truck, kitchen, supply, ration, motor maintenance, ammunition, fuel-truck, or what you will. The simplification of maintenance problems in a uniform motor fleet is too apparent to need discussion, and the simplicity of special maintenance equipment, such as that

for hoisting and towing, for a group of dwarf motor cars, is quite evident. The relative ease of negotiating obstacles with small vehicles by use of block and tackle, with prolonges and man power, by floating in tarpaulins, on rafts, or in bridge pontoons; the ease and speed of embarking, entraining, debarking and detraining jeeps, as compared with the task of performing these same operations with animals; and the possibilities of air transport for a jeep battalion—all are quite plain and undeniable.

Taking up now that question, "What for?", we can give it short shrift. The answer is that this proposed type of artillery should be able to do under certain circumstances what other types couldn't do as well, if at all. Where would all this take place? Well, perhaps in China, where, in some sections, roads are paths of a jeep's breadth, and where canals are common; in Africa, in the Indies, in Norway, on any of the beach heads which troops of the United Nations must and will establish in months to come; in far places where supplies will come in by plane and parachute or not at all; any place where roads aren't, where the going is rough, tough, but not impossible to the narrow, light, close-coupled jeep; in following up a drive on a major front as reinforcing artillery, with the ability of fast displacement over chewed-up terrain. Who cannot think up a lot more?

EDITOR'S NOTE: The Italians have long been pack-artillery enthusiasts. Having a mountainous northern frontier and operating in rugged Ethiopia and Albania, they have incorporated some of these units in all types of divisions, including "conventional" infantry divisions. Recognizing the advantages of motorized "packs" and the necessity of narrow gauges on mountain trails, they have experimented with special vehicles for the purpose. It appears, however, that our flexible and versatile jeep may readily be put to this use, possibly without change.

Although wars and economic rivalries may for longer or shorter periods isolate nations and split them up into separate units, the process is never complete because the intellectual life of the world, as far as science and learning are concerned, is definitely internationalized, and whether we wish it or not an indelible pattern of unity has been woven into the society of mankind. An American soldier wounded on a battlefield in the Far East owes his life to the Japanese scientist, Kitasato, who isolated the bacillus of tetanus. A Russian soldier saved by a blood transfusion is indebted to Landsteiner, an Austrian. A German soldier is shielded from typhoid fever with the help of a Russian, Metchnikoff. A Dutch marine in the East Indies is protected from malaria because of the experiments of an Italian, Grassi; while a British aviator in North Africa escapes death from surgical infection because a Frenchman, Pasteur, and a German, Koch, elaborated a new technique.

—Rockefeller Foundation Review

THE UNEXPECTED ALWAYS HAPPENS—II

By Lieutenant Colonel David S. Larr, GSC

All sins cannot be laid to the captains and lieutenants. For instance:

The colonel of the armored car regiment¹ sat at breakfast. He was distinctly worried. A tall, powerful man and a stern disciplinarian, he thoroughly believed in keeping rigid control of all elements of his command. There was no doubt as to who ran his organization.

It was about an hour after daylight when the regimental signal officer slid into the chair across the tiny table from him. He did not add to the colonel's tranquillity with the information that the "forward link"² had gone out several minutes before. Garbled fragments of a hurried report of enemy movement had been received. Subsequent efforts to contact the first squadron,³ which had the sector above the escarpment nearest Halfaya, had been unavailing, due apparently to some minor breakdown of the headquarters radio set. The signal officer advised that he had checked out of the rear link to division headquarters and was re-tuning that set into the forward link in an effort to find out what was going on. The colonel reflected. The Boche had been "mucking about" for approximately 36 hours. There had been vague reports of vehicles heard, undefined movements seen, an unusual difficulty in getting foot patrols into the German outpost area, and other harbingers of storm to come.

He asked the signal officer what had come over the wire net and was told that nothing had been seen by the second or third squadrons or by the column to the left front. The column on the right front had not yet occupied its daytime position. Inquiry would be made as soon as they arrived, which should be within a few minutes. The wire to division headquarters appeared to have been cut by some wandering truck during the early morning, but the signal officer assured the colonel it would be fixed shortly; his linesmen had been out on it since before daylight. With these reports, the colonel sped the signal officer away with emphatic directions to get something from somewhere in short order.

The bivouac of the regiment's headquarters was spread

¹Corresponds to the U. S. battalion. Commanded by a lieutenant colonel.

²Radio net to forward units.

³Corresponds to U. S. armored company.

AUTHOR'S NOTE: The incident described in this article does not in any way reflect upon the general state of training or combat efficiency of the troops involved. Such occurrences take place in all armies in all parts of the world and will probably continue to do so as long as men retain human frailties. The operation in which this incident occurred resulted in ejection of the German reconnaissance force from the area of the British covering force without material damage to British installations or gain for the Germans.

generally over an area within a radius of about a half-mile from the command post truck. Vehicles were dispersed at least 200 yards apart, as usual. The protective platoon of three armored cars occupied three slight eminences in the flat terrain, to the east, north, and west, as local security. The personal cars of the commander and his immediate staff were generally closest to the CP truck. It was some 22 miles almost due north to Point 200, and the location was well centered behind the curved screen maintained by the regiment. One squadron formed that part of the screen extending from the sea somewhat southeast of Halfaya Pass, six miles across the coastal plain to the bottom of the escarpment. Thence three squadrons held a long semi-circle for more than 40 miles to a point near Maddalena Fort, which was far south and west of the headquarters. An additional squadron of armored cars was attached to the three organic ones of the regiment, which permitted platoon posts about every four miles around the front.

The mission of the regiment was entirely one of security, and observation of enemy movement. The armored car then in use had little offensive power, as it was overwhelmingly out-gunned by German armored cars. Standing orders of the regiment required immediate reports of enemy movement observed, by wire from established OP's, otherwise by radio. Squadrons attacked were to withdraw around the south flank of the covering force proper, to take position in front of the next phase line to the east. The mobile columns, of which there were two above the escarpment at this time, had the mission of harassing and delaying any enemy thrusts into the British-held area. The main body of the covering force would hold its organized position areas until driven out, after which it would delay on successive lines back to the area of the main body some 60 miles east. The colonel's instructions to his squadron commanders had been definite and explicit. If attacked, they would report by radio, then proceed to carry out standing orders at maximum speed without regard to subsequent course of the enemy. They would report by radio again upon arrival in their designated areas in front of the second phase line.

As he finished his breakfast, the commander observed to himself that he would have to do something about these temporary breakdowns in the communication system. It was true the regiment was woefully short of both radio sets and batteries, and he believed in favoring the forward squadrons with the sets available. Still, one could not afford to have these things happen, particularly when the Boche were milling around on their side of the line. He was proud of his regiment. They had gone through the Abyssinian campaign with flying colors.

Three weeks before they had relieved by gradual infiltration along the whole line, the British regiment which had secured the Western Frontier almost from the beginning of the war. He felt distinctly honored at having his regiment selected for such a responsible post, and a glow of pride in the thought that his men would measure up to any demand made upon them.

He walked toward the CP truck. A few low thuds, more sensed than felt, caused him to pause momentarily. Something must be going on up in the area of the column next the escarpment. He would really have to build a fire under his signal officer about this. Nothing particularly unusual or important had gone wrong, the accidents just seemed to have happened all at the same time. At the truck he told the telephone orderly to have the signal officer report to him.

His adjutant showed him the newly arrived sheaf of orders from division headquarters. There were some periodic changes in the radio code. Also amendments to secret standing orders which implied, at least, that the covering force would shortly be augmented and the defensive areas materially strengthened. He noted his adjutant had brought out the file of secret

communications, and spoke to him sharply, directing that they be returned to his personal armored car where they were always kept. He made it a rule that the file should remain in its locked compartment in his own armored car, where they would be safe. Regulations foolishly provided that such communications must be kept in the rear echelon where they were never available. Besides, he could never be sure who might have access to them back there. He believed in safety-first, and did not think it appropriate to push off responsibility for such vital papers on to a subordinate. The adjutant had ironclad instructions never to take the file out of its compartment, and to open it only to deposit and remove necessary papers. The adjutant was the only officer besides himself who carried a key for the compartment.

The signal officer hurried in with a decidedly worried expression. The column on the escarpment made no answer on either wire or radio and neither did the first squadron, which had the sector in front of them. Posts further to the south, as well as the mobile column to the southwest, reported no movement seen. But the column said there was a large dust cloud moving down the escarpment from the vicinity of Halfaya Pass. The



The Pz. Kw. II, standard light (9 tons) German tank. The 3-man crew, protected by 15-mm. armor plate, is armed with a 20-mm. heavy machine gun and one light machine gun in roller type mounting. Maximum road speed is 28 mph; radius of action. 125 miles. Large quantities of these tanks (which are readily convertible to flame-throwers) have been made. The suspension wheels resemble those on our old Christie vehicles. General appearance of the Pz. Kw. II: wide track base, very low silhouette, streamlined.

colonel directed that the rear link radio set be re-tuned with division headquarters immediately and the fact reported. He also sent for the protective platoon commander with the idea of sending his cars in that direction to see what was up.

He walked out and looked toward the north. The dust cloud was certainly visible, low on the horizon. In addition, a faint roar as of far-away motors could be heard. While he waited for the protective platoon commander, it seemed to him that the low vibrations from the motors noticeably increased and the dust cloud grew in volume. He told his adjutant to alert the command post and started across to the signal truck. The protective platoon commander met him on the way and received his instructions, departing on the run. As he arrived at the signal truck, the entire CP came alive as personnel were roused and hastily began to load equipment and prepare to move. In the signal truck a perspiring signal officer and switchboard operator were tensely contacting the elements in the screen to the south and west. Nothing seen. A light on the switchboard which belonged to the second squadron, which was in front of the column to the southwest, kept blinking persistently on and off; the operator, who was checking posts from left to right, was annoyed but continued unmoved in his routine. The colonel stepped to a phone and motioned the switchboard operator to connect him to the line indicated. He heard the second squadron commander state that his right-hand post reported armored cars from the first squadron proceeding southwest across their rear at a high rate, and that some heavy enemy movement must be taking place to the northeast. He was sending a patrol out to investigate.

The wire to division headquarters was still out. A quick question brought information that the radio to division might be in by now. The radio truck was, of course, about 150 yards further on. The colonel looked toward it and could see through the open door of the armored car the operator intent over his set. He made the distance in a time that would have done credit to any track star. The operator, between efforts to conjure results from his set, told him division was very faint indeed, and was apparently desperately inquiring about some report of enemy action overheard from the first squadron. It seemed the squadron had opened up once, then gone off the air and the division commander demanded an explanation.

At this time the colonel remembered that the driver of his own armored car had been sick that morning and he had sent him to the medical officer. He wondered if the man had returned.

He stepped outside again, and one look at the dust cloud sent him toward the CP truck in a dead run. As he went, the armored cars of the protective platoon appeared on the rising ground just north of the perimeter of the CP. They were flying at top speed and the lieutenant waved his flag, "Enemy in sight," as they came over the crest. It was

impossible! It couldn't be! The man was insane! But from the sound of motors now overwhelming all else, there was no doubt that they were about to be run down by something of tremendous proportions. The entire CP was alive to the danger, and as he turned toward his armored car, the colonel could not help but feel a surge of pride at the speed with which they were rising to the emergency.

The cars of the protective platoon remained on the side toward the enemy. The second in command drove up in his armored car and the colonel shouted to him to carry out standing orders and move the CP back to its pre-selected position on the second phase line as fast as he could go. The colonel arrived at his own armored car out of breath and feeling thoroughly angry.

As he leaped up to the top of the turret and slid down inside, he realized with a shock that the driver wasn't there! The motor was not running. His adjutant, who usually rode with him, wasn't there either. He saw his batman running across from his station wagon with an armload of kit, water bottle, pistol, field glasses, etc. The batman flung his load into the open back of the car and the colonel shouted to him to drive. The adjutant was busy about the CP truck, which took slightly longer to prepare for movement than the rest of the vehicles. The batman clambered through the door and slid into the driver's seat as the colonel regarded the oncoming dust, which was now very, very close. The starter of the car ground once or twice—and died away. The CP truck was now loaded and he saw the adjutant measure the distance to the enemy with his eye, then appraise the cargo of the CP truck, flung on helter-skelter and apt to come loose at any time. The adjutant then climbed into the rear of the CP truck to help hold the equipment on, and took off after the remainder of the disappearing vehicles. The colonel shouted to the driver to get going. Nothing happened.

There now remained only the three armored cars of the protective platoon between the colonel and the enemy. He saw around those cars the flash of tracers and the boil of dust as machine-gun fire beat down upon them. The batman shouted, "The starter won't work!" The colonel flung himself over into the driver's seat and stepped on the button. There was no response. A shell exploded nearby and fragments rained on the armor, one or two coming through the open door to glance from the side of the turret and fall spinning on the floor. The colonel leaped from the driver's seat up through the top of the turret and waved to the car of the protective platoon commander which was bearing down upon him with every ounce of speed it could muster. He thought, "The codes!"—and slipped his hand in his pocket to feel for the key of the compartment. It wasn't there! At this moment three black monsters pitched over the ridge about 700 yards to the north, literally flying through the air for several yards before they struck on the descending slope. As with a single thought, machine guns chattered

out, the orange lights flew toward him, and the dust boiled up around. There were two resounding bangs on the rear of the armored car which waited to take him away, and the head of the lieutenant disappeared from the top of the turret as if jerked down by giant hands. The colonel reached for one of the spare cans of gasoline from the rack on his own vehicle. Standing on the hood, he smashed the can across the rim of the opening in the top of the car, drenching the interior. The batman, with superb sang-froid, struck several matches at once and tossed the flaming box-full into the door. There was a boom as the gas caught and the interior became an inferno.

Both colonel and batman, head first, dove together down through the opening in the top of the other car as gears ground and the driver took off toward salvation and safety. Bruised, disheveled, gouged by projections inside the car, the colonel disentangled himself as best he could

from lieutenant and batman as the car jumped and rocked and pitched in wild flight. The colonel with greatest difficulty clambered back and looked out toward the diminishing picture of his own car, surrounded by Germans who ran toward it as ants toward a honey pot.

After several miles, they slowed down as the rear elements of the retiring headquarters began to appear in view. The colonel rode, wedged in the open top of the car, and into his thoughts also came the cold face of the division commander. "Communications of 'secret' and 'most secret' nature will not be carried in combat vehicles." "The — — — — Armored Car Regiment will *maintain* the service of security and observation — — — —; timely report of *all* enemy movement will be furnished the division commander and commanding officers of mobile columns of the outpost." "Every unit, however small, is responsible for its own local security — — — — —, etc., etc."



This photograph gives an excellent idea of typical uniforms, personal equipment, and transportation of officers in Libya. In campaign, certain personal variations are bound to creep into the uniforms worn at any given moment. The staff lieutenant (right foreground) is in full battle-dress except that suspenders are missing. Notice how low-slung a holster is preferred by some.

The officer second from the left appears to be Brigadier John Charles Campbell, D.S.O., M.C., Royal Horse Artillery, the first artilleryman to be awarded the Victoria Cross in the current war. Commissioned in July, 1915, he was mentioned in dispatches in 1916; won his M.C. in 1919; was awarded the D.S.O. on April 1, 1941, for bravery in Libya, and the bar to it 24 days later; and was twice mentioned in dispatches in 1941. Since earning the Victoria Cross, Brigadier Campbell was promoted to Major-General, and later killed in an automobile accident in Cairo.



Photopress, Zurich, courtesy The American Foreign Service Journal

Swiss Alpine Infantry troops on the march somewhere in the Swiss Alps. Switzerland's Army of over 500,000 men has been keeping watch at the front since the beginning of September, 1939.

Switzerland Surrounded

EDITOR'S NOTE: *Authentic descriptions of present-day life abroad are rare, but this graphic account from Europe's only surviving democracy is unquestionably genuine. The writer is a young Swiss woman, part of whose youth was spent in England.*

December 6th, 1941

My dear American friends,

Though I did not write to you for a very long time, please do not think I have forgotten you and I wish to thank you for the interest you take in us by your inquiry of last Xmas. Before this year ends, I therefore will not fail telling you all the news which may interest you. First of all I want to tell you that at home all the family is well in spite of war-times and we feel so much more grateful than often before, now we know that our country was guarded by a kind but undeserved destiny until up to-day. This does not mean, however, that our life is still going on so quietly and free from cares as before the war; we too have to bear all the rationing restrictions which become more heavy every month. I must say our

government has done the utmost possible to procure provisions already before the break-out of war, so that in fact until last spring we could live almost like in times of peace. It will certainly be of interest to you to hear that even in the classical milk-country milk, butter and cheese are rationed now and our world-famous chocolate is so rare that we hardly see any of it. At present, children are not spoiled with sweet things. It must also sound strange to foreigners that in our country with the big works producing electricity by the cheap natural water-power, we are short of electricity this winter. This is a great deal due to the fact that nearly all our railways and factories are transposed to electricity and besides, since coal is short, electricity is often used for heating the rooms. If you consider that already last winter we did not get sufficient coal and this winter we receive but 35% of the pre-war consumption, you can imagine that in our climate we shall not be any too warm! In the office last winter we had to work in rooms with 12-14 C. This winter it is entirely prohibited to

heat with electricity and we confidently hope it will not be a very cold season.

About a year ago, we suddenly were compelled—probably on request of our favourite neighbours—to introduce the black-out after 10 o'clock PM until daybreak. This is really a very disagreeable affair. It seems that at night the illumination of our country gave a good orientation to the RAF on their way to Italy and perhaps it is not known to you that some parts of Switzerland have already suffered damage and loss of people by bombs thrown on Geneva, Lausanne, Basle, Zurich and some peaceful villages near Lake Constance on mistake. Of course, these are only small events considering what English towns must have suffered in the air attacks and our admiration for the brave English people knows no bounds. Though our Government is strictly neutral, we, the people have our own opinion and the hate for the ever quarrelling Germans, of which we have also a good many in our country, is considerable. Their manner of proceeding is simply disgusting for a free and independent nation. It is a shame that all the great benefits of progress experienced during the last years are used for destruction and it looks as if after the war, which will surely take a horrible end, nobody will be satisfied with the result. For many years already we do no more maintain diplomatic relations with Russia, because of our non-approval of the soviet system, but we feel sorry for the unhappy Russian people now entangled in war, after having suffered for so many years.

I believe we shall never forget the most horrible days we had in May, 1940, before the capitulation of France. During two or three weeks, we never knew when our frontiers would be crossed by the German Army to find an easy passage. Probably they expected a heavy resistance on our side and this may be the reason why the unhappy Belgians had to suffer for the second time. In those days we had many sleepless nights, partly with alarms, and people from our frontier towns evacuated with their precious things by car or railway to the Bernese Oberland, the French part of Switzerland, etc. Some people behaved headless, but it is not sure that we in a similar position would have been more clever. I must confess that I too was so upset that I packed by rucksack with all the absolute necessities but I would not even have known where to go to! After all we laugh about our arrangements—we already had procured poison for our darling canary—and to-day I feel ashamed about my unswiss-like behaviour; but then my nerves were simply run down. It must have been the unexpected speed of all events that gave me such a shock.

For many weeks afterwards we had hundreds of French refugees, mostly women and children in a dreadful state in our country and we were so glad we could do at least a share to make their destiny easier to bear. We would have given almost everything away for them, so little we cared more for material things. At the same time about 60,000 soldiers crossed our Jura-frontier not to fall in German

hands: Polish, Belgians, French and their colonists of all colours and a few English. Some French soldiers wept like children, so miserable they felt after the break-down of their native country. All of them were interned. The French and their colonists left just after New Year and now there are about 12,000 internees left, of which the greatest part is Polish. The fate of these people is deplorable, because for the present they are practically homeless. They are mostly interned in villages, for they are good workers and the farmers treat them like their sons, so I do not think they are very unhappy. This autumn I once heard English soldiers who managed to greet with the Bernese "Gruessech." They make promising progress!

I must not forget to tell you that this summer we celebrated two great jubilees: the 650th year of the foundation of the Swiss Confederation and the 750th of our Berne. In one way we thought it not right to hold feasts considering all the misery around our country, but on the other side we found that there was really no reason for us to let "heads hang" and our brave ancestors, who left us such a beautiful country, are worth to be thought of. The fire to light all the bonfires on hills and mountains on Aug. 1st was brought by torch-bearers from the fire on the Rutli—the cradle of our Confederation. We were lucky to have one of the most beautiful days of all the summer and this wonderful event will never be forgotten. We all hope it was not the last time we celebrated as a free and independent nation, for I could not bear the feeling to wake up one morning and be under German authority. Although we have a little army (about 1 million men) compared with other countries, it is, considering the population of 4 millions a considerable number. I am sure our soldiers would fight like lions, because our liberty is worth more than our life.

Later in the summer, there was the new railway-bridge over the Aar to be inaugurated, another occasion for a feast. So jokers used to say that we, people of Berne, will soon be celebrating the 650th feast of the year! The new bridge is a wonderful piece of architecture and the keen long bow is supposed to be one of the largest of a bridge in that height in Europe. Our town has become almost as quiet as a village because of lack of petrol; no cars are allowed to drive and when we see one it is sure to be one of the C.D. Please tell your children that I have already seen a car drawn by horses, which was in fact a funny sight!

I like the Christmas-cards with the snaps of your darling children so much and find it a splendid idea. So I am informed of their growth and progress! I hope you all are well and will be having a merry Xmas and a happy, prosperous New Year. May your country be spared from war, though perhaps it would help to finish the muddle quicker.

With all good wishes from all the family, I remain
Yours sincerely,
M.

Not in the BOOK

IMPROVISED COLLIMATOR SIGHT FOR TRAINING

Even though the collimator sight is being replaced by the panoramic sight, it is probable that some of the initial training of gunners will be accomplished with guns which still have the former sight. To supplement this training, the above sketch shows a dummy collimator sight which can be constructed very easily and cheaply in any workshop. The dimensions have been taken from a working model which has proven very satisfactory as a training aid; however, they need not be strictly adhered to in the construction of similar models.

Through the use of these dummy sights, prospective gunners can become thoroughly familiar with making plateau and drum settings prior to actual training on the guns; four sights can be set on a table so that the gunners can work as a team; therefore they should be built in quantities in order to give more men the opportunity to gain such information and practice.

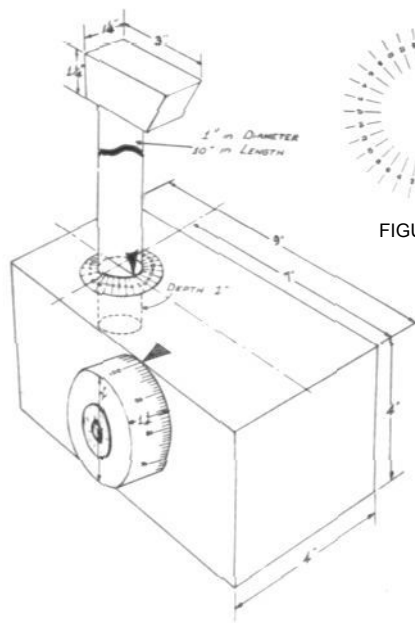

FIGURE 1.

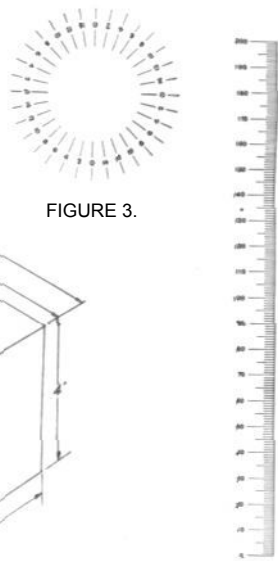

FIGURE 3.

I. G.

FIGURE 2.

Materials for construction:

- 1 piece wood—4" × 4" × 9" (Base).
 - 1 piece wood—1" diameter × 10" or piece of discarded broom handle of approximately the same dimensions (Sight column).
 - 1 piece wood—1 1/4" × 1 1/4" × 3" (Collimator).
 - 1 piece wood—2 1/4" dia. × 1 1/4" (Deflection Drum).
 - 1 plateau scale (Fig. 3).
 - 1 drum scale (Fig. 2). Length of scale should be approximately 1/8" less than the circumference of the deflection drum.
 - 2 indicators (Tin).
- Nail and washer to hold deflection drum in place.

EDITOR'S NOTE: This feature is devoted to ideas sent in by our readers describing methods or devices which, though not specified by official literature, have proved useful in service.

OFFSETS, PLUS OR MINUS?

For a number of years I have had occasion to teach instrument details in the computation of firing data, and found it was more difficult for men to learn the application of offsets than the computations of the amount of the offsets. The manuals speak of the algebraic sums, which immediately scares those that have not studied algebra. Ask the new members how many cannot add algebraically and a number will invariably say they cannot, but I have never come across any that actually could not; it was just a matter of terminology; tell them that it is 10 degrees above 0 and the thermometer goes down 25 degrees, and always they can give the right answer. Point out that when the mercury goes up it has a plus value and when it goes down a minus value. A further example is a clock—when the hand goes forward (clockwise) it is a positive value and backwards (counter-clockwise) a negative one. Then compare the aiming circle's 6400 mils with the 60 minutes of the clock. In fifteen minutes you have laid a solid foundation for application of offsets.

Enlisted men have told me a number of times that the following rules were easier to learn and apply than those given in FM 6-40:

1. The measured angle is the clockwise angle from the target to the aiming point. *If the angle is measured from the aiming point to the target it is given a negative value.**

2. To determine the value of the target offset, face the target; if the guns are on the right add, if on the left subtract. The word GRALS (Guns Right Add Left Subtract) may help in remembering this rule.

3. To determine the value of the aiming point offset, face the guns; if the aiming point is on the right add, if on the left subtract. PRALS is the key.

4. The firing angle is the algebraic sum of the measured angle, target offset, and aiming point offset.

The applications of these rules are:

a. When using a distant aiming point, the value of the firing angle is always positive. If the computed angle is minus, subtract it from 6400. (It is necessary to convert this firing angle to deflection for the type of materiel used.)

b. When using compass, the angle is measured from Y-North (the aiming point) to the target and thus has a negative value. The firing angle also has a negative value. If the computed angle is positive, add it (algebraically) to a minus 6400. When using a compass there is no aiming point offset. The firing angle is announced simply as Compass 3600. No mention is made of its negative value. The fact that the executive subtracts the compass reading from the declination constant may assist in remembering that the firing angle is negative.

c. When making a shift from a base point, the base point is considered the aiming point. If the target is to the left of the base point the measured angle is from the target to the base point, and is positive. If the target is to the right, the

*A clockwise angle from aiming point to target is the same as a counter-clockwise angle from target to aiming point, and thus has a negative value. By using angles thus measured as negative angles, the same rules for applying offsets apply regardless of the method of computing the firing angle.

angle is measured from base point to the target and has a negative value. If the firing angle is positive the shift is left, if negative the shift is right. It will be noted that this is the rule always used at the guns, i.e., left add, right subtract.

In applying rules 2 and 3 it is not necessary to visualize the measured angle; simply face the *target* for the target offset and face the *guns* for the aiming point offset.

CAPTAIN JOHN C. KERR, FA.

NIGHT ILLUMINATION OF AIMING STAKES

Lucite, the trade-named DuPont plastic, will "pipe" light, and while it emits a slight side glow there are no side rays. One size rod fits perfectly inside the aiming stake, and sells for only 63c per foot.

I had Private O'Connor fix an old aiming stake as shown in the sketch. A small flashlight was screwed into the top of the stake, bulb down. He cut a quarter-inch slit in the stake, four inches long, and behind it wedged a five-inch length of Lucite rod. It worked fine, but was improved by painting the bottom of the rod white to reflect the light up and increase the glow a little. For different colored lights, just dye the Lucite as desired.

This method has several advantages over the present flashlight system:

1. The light is sturdy and protected from weather and shock.
2. It is easy to sight on.
3. The same stakes can be used during the day.
4. The light is visible only from a direct angle—no rays are formed, so no light escapes from the sides.

PVT. GILBERT COHN,
Battery D, 35th F.A.



A FAST COORDINATE SCALE FOR T.D. UNITS

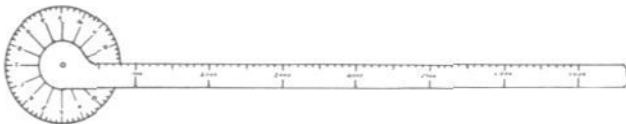

Tank Destroyer Battalions need a fast, safe way to identify areas—one which can be flashed by radio in the clear. The 645th TD Bn has evolved a method that meets these requirements, and which has two variables which are changed daily for secrecy.

The only equipment is a circular protractor with attached scales, made from either celluloid or cardboard.*

When designating the map (substitute) in the field order, a Battalion Point is stated, such as D-18-E. The first two elements specify the grid intersection (generally toward the southwest corner of the map) over which the protractor is to be centered; the final letter indicates the point of the protractor over which the scale is to be fastened for the day.

To read the coordinates of a point, swing the arm (with attached protractor) so the calibrated edge passes through the point of interest. Read the protractor on the Y-line, and the scale directly. A point is located on the map by reverse procedure, of course. Accuracy is ample for designating the *areas* in which TD battalions are interested, and the speed is remarkable.

LT. COL. PAUL B. BELL, FA.

*Units preferring commercial items are referred to navigation aids; one such device is flexible and transparent, with a 6¼" compass rose and 20" arm, and retails for \$2.75. Home-made devices will be found more fool-proof if markings on each half of the protractor are identical.—Ed.

USEFUL EXPEDIENTS

ANTI-TANK PRACTICE

After trying the recording device shown in Figure 1 of Colonel Bell's article (page 218, March, 1942, JOURNAL), and finding it satisfactory but difficult to construct in the field, the following simplified substitute was devised:

- a. A block of wood whittled to fit in the muzzle of the 37-mm. gun.
- b. A channel bored through the block to just allow the snug passage of a pencil.
- c. A rubber band attaching the pencil to the block of wood so that the point is well beyond the outer end of the block.

A piece of one-inch board with a groove is ample. The pencil does not need to be centered, just firm. The pencil should have as soft a lead as possible; a large lead carpenter's pencil is excellent.

One section produces the above using bamboo and saves no end of carpentry.

The assistance in instruction is well worth the use of this gadget.

SIGHT DISPLACEMENT COMPENSATION

I have a turntable mount for the light howitzer that revolves around the sight rather than the center of the gun. Do you want the dope or doesn't anyone else have to cover 4200-mil sectors? And by the way, which is No. 1 gun in this kind of a fix? I still don't know.

LT. COL. W. C. GOESSLING.

*EDITOR'S NOTE: Dope of this kind is just what all units are calling for, and we would like to learn of the various devices which have been worked out. Meantime, Captain Little's pragmatic solution on page 327 of the April issue should help.

QUICK FIGURING

An instructor once told me that an approximate method for determining the elevation for a 75-mm. gun, normal charge, was to use the formula:

Elevation = $4R(R + 4)$, where R = range in thousands of yards.

I found that the value of C = $4/3$ (taken to nearest even mil).

Carrying the idea still further, I found the following formulas will apply for a 155-mm. howitzer:

	Elevation	c
Charge 4	$6R(R + 6)$	2 R
Charge 5	$5R(R + 5)$	$4/3$ R
Charge 6	$4R(R + 4)$	R

and for a 105-mm. howitzer:

	Elevation	c
Charge 4	$8R(R + 6)$	$2 R + 2$
Charge 5	$5R(R + 6)$	$R + 2$
Charge 6	$4R(R + 6)$	R

For the howitzers, 2 C's should be added to near ranges, 2 C's subtracted from far ranges. These values will hold with sufficient accuracy at the intermediate ranges, and can be memorized easily for any type of material to provide a means of determining initial data without the use of Range Tables.

—BY LT. R. J. BAKER.

EDITOR'S NOTE: These formulas, especially those for c, are remarkably accurate. Except at extreme ranges, c is always correct within one mil. Elevations are sufficiently accurate to give sensings on first shots and to serve as rough checks. These or similar formulas deserve a place in the notebook of every officer and chief of section.

Diary of War Events

APRIL, 1942

- 1st Hand-to-hand fighting on Bataan beats back major Jap attack supported by warships.
Mindanao defenders successfully raid Japs.
Burmese British, encircled below Prome, fall back to that city.
Chinese escape from fallen Toungoo after 7-day battle.
Thirty-three Jap planes destroyed over Timor and New Guinea in last three days.
British supply ships for Russia reach port despite German attack.
U. S. Navy has sunk 28 enemy subs, 21 in Atlantic, 7 in Pacific.
- 2nd Jap attack cracks left center of main Bataan defense line; counter-attack closes it, trapping advance units.
Heavy fighting on Leningrad and Kalinin fronts.
British bomb Paris truck plant, rail centers in Germany, lose 15 planes.
Fourteen Axis planes downed over Malta.
- 3rd Aircraft tender *Langley*, tanker, and destroyer revealed sunk in Southwest Pacific a month ago, with estimated loss of 700.
Light Jap attacks on Bataan thrown back with heavy losses.
U. S. Army bombers raid Andaman Islands, set Jap cruiser on fire, damage troop ship and transport.
British abandon Prome, Burmese communications center. Chinese advance on Toungoo from north.
- 4th Bataan activity reduced to patrol skirmishes.
Navy announces sub-sinking of light Jap cruiser off Java recently, damaging of another and two seaplane tenders, supply ship, and barge transport.
British withdraw from Prome, Mandalay bombed.
Six Jap planes shot down over Timor, four over Port Darwin.
British bomb French rail centers in daylight, lose 11 planes. Germans bomb West England.
Four ships sunk in Caribbean and Atlantic.
- 5th Japs bomb Ceylon with 75 planes, losing 27. Air raids on Darwin, New Guinea, and Timor cost them 18 planes lost, 17 damaged.
India-based U. S. Army bombers fire Rangoon docks. British continue Burmese withdrawal.
Japs lose heavily making small advances on Bataan. East shore barge landing prevented.
Sub sinks one merchantman off our Atlantic coast.
- 6th First Jap bombs on India fall on two coast towns between Calcutta and Madras.
Mandalay wrecked by Jap bombers.
Jap assault troops on Bataan are supported by dive bombers and artillery firing from barges off east shore.
Jap freighter and two tankers sunk by U. S. subs.
Over 300 British planes bomb France and Germany.
- 7th Heavy casualties on both sides as Japs advance on Bataan. U. S. field hospital bombed.
Russian supplies reach besieged Leningrad by rail.
Jap airfield at Lae, New Guinea, bombed.
- 8th Bataan defenders withdraw to new line, resist successive Jap attacks.
British strengthen line 40 miles north of Prome. Japs attack British naval units in Bay of Bengal.
Japs, bombed again on Timor, occupy island in Admiralty group, 170 miles north of New Guinea.
Two merchant ships sunk off our Atlantic coast.
- 9th Bataan falls. Defenders unable to beat off enveloping movement on east flank. Troops there put at 38,853. Corregidor and other Manila Bay islands still in U. S. hands.
Jap planes sink two 10,000-ton British cruisers in Indian Ocean, raid Ceylon naval base.
Reinforced American volunteer pilots in Burma down 10 Jap planes without a loss. Jap base on New Britain bombed.
British sink 10,000-ton Italian cruiser in Mediterranean.
- 10 Thirty-five hundred sailors and marines evacuated to Corregidor before Bataan fell. Island shelled from both sides.
British aircraft-carrier *Hermes* sunk by Jap dive bombers off Ceylon.
Indian Ocean supply lines seriously threatened.
Japs push three-pronged attack on Chinese defenses north of Toungoo.
Jap advance up Irrawaddy River imperils Prome flank.
Libyan Germans feel out British strength west of Tobruk. British subs sink four supply ships in Mediterranean.
- 11 Japs gain six beachheads on Cebu Islands, south of Luzon, land 12,000 troops. Heavy shelling and bombing of Corregidor continues.
Fatigue, malaria, and malnutrition revealed to have been Bataan defenders' chief difficulties.
Jap advance endangers Chinese north of Prome; British withdraw on Irrawaddy.
U. S. sub sinks Jap merchant ship and sub-chaser. Another U. S. sub, overdue in Java waters, presumed lost.
Two more U. S. merchant ships sunk off our Atlantic coast.
- 12th Jap bombers attack Corregidor 12 times in 24 hours; damage slight.
Bomb hits Jap aircraft carrier directly, near New Britain; United Nations bombers strike at Timor, New Guinea, and Solomon Islands.
British withdraw as Japs push toward central Burma oil fields.
German tanks attack on southern Russian front.
British bomb channel ports.
- 13th Jap naval squadron in Bay of Bengal apparently includes three battleships, five aircraft carriers. Every plane at Ceylon naval base was put out of action by Jap bombing.
Jap small-boat fleet smashed by Corregidor artillery. Ten more bombings in day.
British bomb Italian cities, French and German targets.
Six ships sunk by enemy subs in West Atlantic waters, four of them off Brazil.
- 14th Japs in Burma reach point halfway between Prome and Irrawaddy oilfields. US fliers there destroy 10 Jap planes. British bomb Jap-held Andaman islands, destroy 13 planes.
Resistance to Jap invasion of Cebu continues. Corregidor bombardment renewed.
Four more ships sunk by subs in western Atlantic.
- 15th Thirteen US bombers raid wide Philippine area for two days, using island bases. Four Jap ships sunk, Nichols Field and Davao base damaged.
Japs, within 20 miles of Central Burma oilfields, launch new drive on upper Salween River.
Russians increase pressure on Bryansk sector, claim only 80 out of 280 German divisions not used in winter campaign.
British bomb Ruhr, Germans bomb northeast England.
Two US vessels sunk off our Atlantic coast.
- 16th More than 400 Spitfires, plus bombers, raid French objectives all day.
British also bomb Ruhr, Low Countries.
Japs land in force on Panay, Central Philippines island. Corregidor artillery duel continues.
Jap airport on Timor bombed.
Three merchantmen sunk off our Atlantic coast.
- 17th Retreating British in Burma destroy oil fields.
French coast bombed for sixth day. British make daylight raid near Munich.
Thirty-five thousand combat troops, 25,000 civilians were captured by Japs on Bataan.
- 18th Four Jap cities, including Tokyo, bombed by American army planes.
Bombing and shelling of Corregidor lessens. Several batteries on Bataan silenced. City of Cebu in Jap hands and on fire.
US bombers attack Rangoon and New Britain.
Chinese send reinforcements to heavily pressed Sittang River sector.
- 19th Cebu, Panay, and isolated north Luzon forces still resisting Jap Philippine advance.
Chinese take over all Burmese communications from retreating British. RAF bombs Jap planes on Andaman Islands.
Germans using planes in quantity in Russia.
Enemy sub harmlessly shells Curacao oil installations.
- 20th Chinese attack recaptures part of Burma oilfields, frees encircled British.
New Jap landings made on Panay; Corregidor heavily shelled.
Forty grounded Jap planes destroyed on New Guinea.
Japs say their cities bombed by 10 planes, some of which escaped toward China.
- 21st Chinese counterattack in Burma oilfields, gain three more miles.
Japs gain on Panay. Manila Bay forts only slightly damaged.
Jap New Guinea headquarters and fuel dump destroyed by bombs.

- 22nd Commando raid breaks through Boulogne defenses.
Russians, bogged by thaw in south, concentrate on Finnish sector.
Japs advance on whole Burma front, using their Malaya forces.
Jap New Britain base fired, New Guinea air raid beaten off.
US merchant ship sunk in Caribbean.
- 23rd US bomber and crew interned in Russia; lost way to base after bombing of Japan.
- 24th Japs gain 80 miles in Burma, are within 100 miles of Mandalay.
Chinese counterattack to forestall flanking of whole line.
Jap New Guinea base heavily bombed again.
Heaviest RAF raid of war sets huge fires at Rostock, shipping port for north Russian front and Heinkel plane plant site.
- 25th US troops occupy Free French New Caledonia, island on Australian supply line.
Jap New Guinea air base damaged by bombs.
Japs within 75 miles of Mandalay.
British bomb Rostock again; Germans, British channel ports.
From Malta, British bomb Sicilian air base.
Subs sink two more US ships off our coasts.
- 26th British bomb Czech munitions factory, Rostock again. Luftwaffe attacks Leningrad as air activity increases.
British sink four, damage two Axis Mediterranean supply ships.
US planes down 11 of 33 Jap bombers over Darwin, Australia.
- Chinese check Japs on east Burma front; Jap advance in center continues toward Mandalay.
- 27th Japs, approaching Mandalay-Lashio railway, are due-east of Mandalay.
US planes drive off Jap planes scouting New Caledonia.
Corregidor artillery breaks up enemy concentrations on Bataan.
US destroyer sunk off Florida by "underwater explosion."
- 28th Japs nearing Lashio, gateway to Burma road, but lose seven planes in Darwin raid.
Germans bombing southern Russian front heavily as thaw ends.
British bombing of continent continues.
Two Axis Mediterranean supply ships sunk.
- 29th Japs reach outskirts of Lashio, advance on western front also.
US planes there down 22 Jap planes.
US heavy bombers severely damage Rangoon docks and other military installations.
Corregidor guns sink armed Jap ship.
US reinforcements reach Australia.
Germans make "reprisal" raid on York.
- 30th Burning Lashio in Jap hands; lease-lend stocks destroyed. Split British and Chinese forces to the south face encirclement.
Russians attacking on entire front.
Twenty grounded Jap planes smashed at Lae, New Guinea.

C & R TOPS

How can we stop the wear on the canvas top of the command car? The top is stretched tightly over the steel bows, the bows rub and rub and the first thing you know, there's a hole. Sometimes the steel bows rust, the rust spreads into the canvas, weakens it and again: a hole.

When the top is down, the bows pound and pound on the canvas, breaking the rear window glass, banging little holes in the canvas. What are we going to do?

Lt. Adair C. Wilber, Motor Officer out at Fort Sill, Oklahoma, has an idea to cut this kind of stuff out, to stop the bows pounding the canvas when the top is folded down. He and Lt. Albert Bolsinger of the 8th Observation Bn. removed the tacks that support the rear curtain and sewed the rear curtain right to the top. They reinforced the seam with another strip of canvas.

Now when the driver wants to put the top down, he unfastens the grommets and, starting at the rear, rolls the top toward the front. Then he folds the bows down and lays the rolled top right on it and fastens it with the straps that come with the car. The steel bows will no longer pound the ears off on the canvas.

As for the bows rubbing holes in the canvas when the top is up, the only thing to do, it seems, is to reinforce the vulnerable spots with strips of canvas—and keep the bows painted and free of rust.

Or do you have a better idea?

Sgt. George E. Easom, Co. C., 53d QM Regt., who works over in the Holabird Upholstery bay, put in a word about guys who fold the top of the command car down without unfastening the grommets on both sides at the rear.

The word was . . . !

"Nine out of ten command car tops that come in here," said Sgt. Easom, "are ripped on both sides at the rear because these guys don't unfasten the grommets when they put the top down. They give a yank forward and the canvas tears. A lot of times they don't fold the top down properly—so the bows break the rear window."

The Sgt. spit on the floor, "You know what the hell's the matter? These suckers don't take care because it ain't their cars—they don't have to fix them and they don't have to pay for them."

We've got a sneaking suspicion that the Sergeant knows whereof he speaks.

A driver whose brand new Diamond T was towed in with a burnt out engine after only 27 miles of operation, explained, "Yessir, I checked on everything before I started out. I sat in the cab warming 'er up for at least ten minutes. I watched all the gauges, and when the heat indicator stayed at zero I knew everything was O.K. so I started out on the run." (The cooling system was empty.) Can you take a hint?

—*Army Motors.*

BOOK REVIEWS

THE VALOR OF IGNORANCE. By Homer Lea. Harper and Brothers, New York. \$2.50.

In the late '90's a little, hunchbacked student at Stanford University crossed swords with its peaceable president, David Starr Jordan. The youngster of distorted spine had a piercing mind, a clairvoyant vision, and *knew* that the true "yellow peril" was not the people of the dying Manchu Dynasty. He rightly assayed the stuff of which the Chinese were made, foresaw their destiny, aligned himself with Dr. Sun Yat-Sen, and furthered the Chinese Revolution financially, politically, and personally on the field of battle.

The conclusions drawn from his studies were confirmed by travel and personal acquaintance with places and people. The Japanese were ambitious, single-minded, obsessed with expansion. Where?—the answer was obvious. How? And how might they be countered? Lea's personal exploration of our Pacific coast yielded concrete data.

The results were discouraging, disheartening, even horrifying, particularly when viewed against the background of our armed forces of that time. The country must be made aware of the situation, so he wrote this book and Harper's published it in 1909. Its immense importance was recognized by the late Lt. Gen. Adna R. Chaffee and Maj. Gen. J. P. Story, both of whom wrote introductions. A storm of pacifist abuse arose, 18,000 copies were sold, but in 1922 the book went out of print. Harper has wisely republished it, with a biographical study of Lea by Clare Boothe.

The volume is in two books. The second is the concrete one, the first more philosophical—but don't shy away because of that term, for the depth and timelessness of Lea's understanding and his most fascinating passages are

in this first part. The life-span and life-cycle of nations, and the inevitability of this change, are crystal-clear. Lea's grasp of changing space; "geo-politics"; nations' dependence on trained military power from the cradle to their grave; what public wealth really is, and its role in modern warfare; the idiocy of disarmament—these are all among the things giving Book I transcendent interest and importance.

Lea was no mere theorist, but one of those rare people who can develop a thesis and apply it unerringly. Naturally his figures are those of thirty-five years ago, and some allowances must be made for a few other changes. Personal strength, too, upsets some calculations—MacArthur and his men made Luzon harder to crack than had been expected. On the other hand, very calmly, very clearly, Lea stated, charted, and diagrammed the precise strategy the Japs would use to secure Manila, and his time allowance of three weeks was amazingly close to the actual twenty-six days.

We therefore should pay close heed to Lea's analysis of naval strategy and tactics, and above all to his forecasts for our mainland. He understood military geography, and realized the effects of the peculiar geography of our Ninth Corps Area with its few coastal approaches from the east, its mountain walls and desert moats. From the days of the earliest explorers, the San Francisco area has been recognized as the key to the west, and Lea was particularly well acquainted with this region. Not only was he reared and schooled here, but later he spent over seven months intimately exploring valleys, mountains, and deserts. His picture is graphic, startlingly accurate, and should be known by us all.

DISCOUNT OFFER

The U. S. Field Artillery Association will obtain for its members, books (texts, biographies, histories, fiction) at the following discounts for cash with order or prompt payment of first billing:

On orders amounting to at least \$2.50, 10%

On orders amounting to \$10.00 or more, 15%

No discount possible on Government publications.

We pay postage.

JAPAN'S DREAM OF WORLD EMPIRE: THE TANAKA MEMORIAL. Edited and with an introduction by Carl Crow. Harper and Brothers, 1942. \$1.25.

In the late sixteenth century Japan's warrior-ruler Hideyoshi embarked on the conquest of Asia. For generations the Japanese pirates had ravaged not only the China coast, but points as distant as Siam and Luzon. Hideyoshi, however, was able to weld the feudal groups into a single military machine, and was determined to subjugate China; subordinate leaders would receive grants near India, with the privilege of extending their domains in that direction.

Korea was the stumbling block. It took seven years to conquer the peninsula, the Japs never crossed the Chinese border, and Hideyoshi's death brought a bitter controversy over his successor. A magnificent precedent of looting was established, one which the Axis follows today; the Japs succeeded in subduing, impoverishing, and almost annihilating Korea, and of transferring its cultural assets to the islands. This done, the Japs withdrew into their shell for over two hundred years, until compelled by Commodore Perry to reopen the country.

Japanese nationalism still centered in the emperor. Intercourse with the rest of the world was acceptable only with the thought it would eventually give him the position in which he rightfully belonged. Reading, of course, "Japan" for the emperor or his pronouns. Indeed, Lord Hotta, the prime minister who submitted the Townsend Harris treaty to the emperor for approval, wrote in a memorial, ". . . in establishing relations with foreign countries, the object should always be kept in view of laying a foundation for securing the hegemony over all nations. . . . An alliance . . . should also be directed toward protecting harmless but powerless nations."

From then to now, such thoughts have been uppermost in Japanese minds. No incident but was wrung dry of its possibilities for Japanese advantage. At the start of World War I, Japan hesitated to act under her alliance with England until further concessions were granted. And less than a year later she tried, under the cloak of war to impose the infamous Twenty-one Demands upon China.

The Tanaka Memorial is wholly consistent with this background, and with Japan's actions since it was presented to the emperor on July 25, 1927. Technically it is a resume of an eleven-day meeting held from June 27th to July 7th, attended by all the civil and military officers connected with Manchuria and Mongolia. The military, imperialistic, and economic aspects of that region were carefully examined, with particular reference to the strengthening of Japanese political domination and for the exploiting of natural resources. As to methods, "For the sake of self-protection as well as the protection of others, Japan cannot remove the difficulties in

Important for 33 Years



but



Largely Overlooked

THE VALOR OF IGNORANCE

by HOMER LEA

\$2.50

(See Discount Offer, Page 490)



Views clearly

The life-span of nations

**The necessity for continuous
military strength**

**What modern transportation
means**

**The causes for American-
Japanese war**

**Inevitable results of Japanese
expansion forces**

**Where the United States fits into
the picture**

**"Global War," which is not so
new a thought as we believed**

**Japanese strategy (Lea was
absolutely right in his
Philippine forecasts)**

Japanese plans for our mainland



Order through

U. S. FIELD ARTILLERY ASSOCIATION

1218 Connecticut Avenue

Washington, D. C.

ENLISTED MEN! CAN YOU DRAW A MORAL?

Here's one as easy as drawing your pay

IN THE LAST MONTH MORE THAN 40 ENLISTED MEN WHO SUBSCRIBE TO *THE JOURNAL* HAVE WRITTEN US CHANGING THEIR ADDRESSES TO OFFICERS' CANDIDATE SCHOOL, FORT SILL, OKLA.

AND WE CAN BARELY KEEP UP WITH THE PROMOTIONS OF OUR ENLISTED SUBSCRIBERS.

THE MORAL IS: READERS OF *THE FIELD ARTILLERY JOURNAL* GET AHEAD.

The Journal is more than a technical magazine for officers. It's full of material that can't fail to interest and help artillerymen of every grade. Try it and see.

USE SUBSCRIPTION BLANK ON PAGE 496

THE FIELD ARTILLERY JOURNAL
1218 Connecticut Ave., Washington, D. C.

Eastern Asia unless she adopts a policy of 'Blood and Iron.'" Further manipulation of the Koreans was frankly discussed, and the transportation systems of the area most fully explored. Although there appears a plaintive wail that although the Chinese "have no scientific knowledge of the exchange value of gold and silver they always gain in the transaction," the Japs show themselves fully aware of the advantages of encouraging other nations to become minority shareholders in new ventures so they could be properly hornswoggled.

The Tanaka Memorial is well named the "Mein Kampf" of Japan, though its very existence has been denied by the Japs. Its credibility does not depend on any of the circumstances of its publication, nor suffer from official denials. It is in complete accord with the thoughts of the Jap militarists of whom Tanaka was the leader, and is completely confirmed by all events since it was written. As Mr. Crow says, "If the memorial was never written and never presented to the emperor, then it is a very curious and unaccountable circumstance that it should form the basis for Japanese policy." Since it has proved so authoritative so far, and not all of its predictions have yet occurred, we should all be acquainted with it—especially as it is infinitely more readable than Hitler's corresponding tome.

The following books on **EMPLOYMENT OF ARMORED UNITS**

Are Now Available



The Assault Gun Section and Platoon 60c



Fire Control and Coordination 25c



Combat Practice Firing—Armored Units 25c



Armored Division Artillery 25c

On all orders of 200 or more copies, a discount of 10% is allowed for remittance with order.

Order from

**THE
U. S. FIELD ARTILLERY ASSOCIATION**
1218 Connecticut Avenue Washington, D. C.

THE MAN WHO SOLD LOUISIANA. By E. Wilson Lyon.
University of Oklahoma Press, Norman, 1942. \$2.75.

This biography of the man who, after Napoleon, had the most to do with the French end of the Louisiana Purchase sheds new light on this country's most advantageous real estate deal. It is also the story of one of France's most remarkable public servants, Barbe-Marbois, a man who was in office almost continuously for 66 years, serving successively the Bourbons, the Revolution, the Directory, Napoleon, Bourbons again and Louis Philippe. A political moderate in a time of constant change, Barbe-Marbois was the prototype of the modern administrator, a man who holds office in spite of partisanship because he is honest and efficient. Mr. Lyon shows how Napoleon enormously expanded our national horizons by changing a negotiation for navigation rights to the Mississippi River into a sale of a huge territory. "They ask for only one town in Louisiana," the realistic Emperor said, "but I already consider the colony as completely lost, and it seems to me that in the hands of that growing power, it will be more useful to the policy, and even to the commerce of France than if I should try to keep it." In this tremendous transaction Barbe-Marbois was Napoleon's negotiator, and in this clear and scholarly biography he takes on some of the greatness of the business he handled.

—L. B. C.

DEFENSE WILL NOT WIN THE WAR. By Lieut. Col. W. F. Kernan. Little, Brown and Company, 1942. \$1.50.

This little book, dedicated to the Principle of the Offensive, has captured the imagination and the book reviewers of the country. Its title is of course a military truism—no war was ever won by mere defense. It is, however, a truism that it is well to bring forcefully to the public attention. The dual theme is consistent for the first 148 pages: victory requires an offensive, and our strength should be thrown "immediately, daringly and decisively, in the direction where it will do the most good, i.e., where it will be most likely to bring victory." More the pity, then, that three major defects mar and almost ruin the effect.

Colonel Kernan has a phobia for what he terms "the staff complex." It is true that in one brief passage he admits that "no one will deny that any commander worthy of the name must always be to a very great extent dependent on his staff." The fault, however, lies in his failure to recognize that mediocrity is as apt to appear in the line as on the staff, and that no single group has a monopoly or is devoid of intelligence. The carping against a staff *per se* simply goes against the facts, however much one may be inclined to agree with his judgment of certain types and individuals.

Japan is viewed as a tool completely subservient to Germany, attacking Pearl Harbor, the Philippines, and Malaya under direct orders. This approach ignores Japan's history; her picking up in 1853 the threads she laid aside two hundred years before; her record of aggression, unbroken since the China war of the gay nineties; her unbounded ambition as shown, *inter alia*, by the 1915 demands upon China and the more recent encroachments in Manchuria and in China herself; and above all, the fact that Japan's present activity is designed to place her in a favorable position regardless of the outcome in Europe. Despite Hitler's world-wide designs, the waves of his conquests have not yet reached Asia. Japan is not a vassal—yet. Her every action is dictated by only one thing, hard-headed self-interest.

The most serious flaw, however, is the advocacy of an attack on Italy. Colonel Kernan admits that such a move would require for a considerable time the concentration of practically all the facilities of England and the United States, yet this action would run counter to his own requirement of attacking the enemy directly, always aiming for his heart. True enough, Allied occupation of Italy would undoubtedly stimulate the conquered countries to open revolt. But what would be our military gain? Would we not then be isolated as on an island, with Germany still roaming at large and accessible only by an Alpine advance or one along the littoral? Gibraltar, Malta, Suez, and North Africa would be relieved wholly or in part, but we would have squandered much of our strength on an unnecessary intermediate objective. Far better to apply *properly* the colonel's generality:



HOW TO PRODUCE AN EFFICIENT FIRING BATTERY

By Majors H. F. Handy and V. F. Burger

20c single copy

15c each in lots of 10 or more

Write for quotation on quantity orders

This 62-page booklet is chock-full of practical advice for the battery executive and all members of the firing battery.

CONTENTS

General
 Training of the Firing Battery
 Suggestions for the Executive
 Service Practice
 Night Occupation
 Recording
 Certain Common Errors, Their Causes and Prevention
 Useful Expedients
 Safety Officer
 Recapitulation

Thousands of copies have been sold.

Order your copy today.

U. S. FIELD ARTILLERY ASSOCIATION
1218 Connecticut Ave., Washington, D. C.

HOW TO SAY IT IN SPANISH

75c

(See discount offer on page 490)

For the soldier who wants a *quick* introduction to Spanish, to make his needs understood.

U. S. FIELD ARTILLERY ASSOCIATION
1218 Connecticut Ave., Washington, D. C.

OUR FUTURE IN THE PACIFIC



AND OUR PAST . . .

Our aim was free commerce, the open door, and the liberation of national groups.

Japan wanted economic, cultural and political monopoly.

We thought Japan would not fight because it was economically unsound to do so.

Japan thought we would not fight because we were fat with money, weak and divided.

AMERICA IN THE NEW PACIFIC

by George E. Taylor tells the vital story of how these mutual misappraisals resulted in the present conflict. This is the most complete and valuable book on our Eastern relations that has appeared in a long while. In reaching the conclusion that "the liberation and modernization of Asia is essential to the continuation of democratic institutions in America," the author, an expert on the Pacific, bases his thesis on up-to-the-minute history and drafts a blueprint for our victorious future in the Pacific.

\$1.75

(See Discount Offer, page 490)

Order through

**THE
U. S. FIELD ARTILLERY ASSOCIATION
1218 Connecticut Avenue Washington, D. C.**



an attack on the periphery does not affect the center, but a decisive attack on the center carries the periphery with it.

It is always easier to give advice than to receive it, or than to apply even one's own principles accurately. *Defense Will Not Win the War* proves the truth of this platitude.

THE OFFICERS' GUIDE, Eighth Edition. The Military Service Publishing Company, Harrisburg. \$2.50.

Very deservedly, this excellent book is having a tremendous sale. Such circulation permits the publishers to keep the work up-to-the-minute by revising it just as soon as changes are warranted. This of course does not render earlier editions obsolete, but does insure the buyer of receiving the very latest information.

This new edition (the last one was issued only two months ago) shows the editor's care. The chapter on "Supply" contains Circular 105, April 10, 1942, "Simplified Accounting Procedure for Organization Property," and in proper place is given Circular 111, April 15th, the latest promotion regulations. The "Uniform and Equipment" chapter has illustrations of the new uniforms, and new colored plates of Army and Civilian Defense insignia. New sections have been added on censoring soldiers' mail and the duties of Public Relations Officers. Numerous other changes have also been made so that *The Officers' Guide* retains its "must" position.

PEMBERTON, DEFENDER OF VICKSBURG. By John C. Pemberton. With a foreword by Douglas Southall Freeman. University of North Carolina Press. Chapel Hill, 1942. \$3.50.

The university presses are making noteworthy contributions to the literature of American military history, and in the field of Civil War biography the University of North Carolina has few equals. This is the first full length life of Pemberton, and it is written by his grand son. Not unnaturally the bulk of the book is taken up with the Vicksburg campaign. The author concludes that Joseph E. Johnston should bear a share of the blame for the Vicksburg disaster. His instructions and suggestions gave little help and added considerable confusion to Pemberton's already complicated problem; and Johnston made no effective attempt to relieve Pemberton.

In truth, no disgrace need be attached to Pemberton's defeat. Grant was at his best in the Vicksburg campaign, and at his best he was unbeatable. It may be added in passing that the author's time would have been well repaid, and his estimate of Grant appreciably heightened, had he glanced at General J. F. C. Fuller's study of Grant's generalship. The essence of the matter was

that Pemberton was tied to the defense of one point—Vicksburg. This not only hampered him in the maneuvers and battles which preceded the siege, but it led to his withdrawing and shutting himself up in Vicksburg; and once he had lost his power to maneuver his ultimate surrender was inevitable.

Pemberton was a singular figure in many respects. A Philadelphian of solid Northern ancestry, he nonetheless elected to join the Confederacy, and his reward was persistent suspicion from the Southerners whose cause he supported. After Vicksburg he was unable to get another command, so he resigned his commission as lieutenant general and was reappointed as lieutenant colonel of artillery, in which branch he had served in the United States Army before the war. But he was never very highly regarded in the South, and his natural reserve and dignity were misinterpreted as surliness. His grandson here succeeds in presenting a pleasing and sympathetic portrait.

—H. S. F.

"WHAT THE CITIZEN SHOULD KNOW ABOUT . . ."

W. W. Norton & Company have just added three excellent volumes to this series which started with . . . *The Army* and . . . *The Navy*.

Fletcher Pratt¹ is almost up to his usual standard in explaining methods, words, and terms of the army and navy. Arranged in alphabetical order for ready reference, it covers the field from Able Seaman to Y-Gun in clear language for the layman yet in sufficient detail to be useful on desk or dayroom table. Branches, weapons, equipment, tactics, and innumerable other categories are listed, defined, and frequently illustrated by Andre Jandot's excellent line drawings. Despite the professional help and advice acknowledged by Mr. Pratt, there are such minor errors as grouping the 155-mm. gun as a medium weapon and stating that an artillery gun corresponds to an infantry platoon and is commanded by a lieutenant. The definitions are accurate enough in the main, however.

Both army and navy air forces are covered in a book by a World War flyer now back in harness.² It is up-to-the-minute, being based on the March 9th reorganization of the War Department. All types of training, both flying and non-flying; procurement; experimental engineering; proving ground work—all are clearly outlined. Col. Hartney even includes chapters on marine and coast guard aviation, the CAA and CAB, Civil Air Patrol, air warfare and defense against it, and unity of command. Alan Haemer made the fine drawings.

Lt. Col. Paul W. Thompson, CE, has done well by his own branch.³ He clearly shows the teamwork that

¹*What the Citizen Should Know about Modern War*, \$2.50.

²*What the Citizen Should Know about the Air Forces*. By Lt. Col. Harold E. Hartney. \$2.50.

³*What the Citizen Should Know about the Army Engineers*. \$2.50.

ARMY WIVES NEED HELP

THERE ARE SO MANY NEW ONES
WITH SO MUCH TO LEARN IN SO
LITTLE TIME

Give Her
THE

ARMY WIFE

What she ought to know about the customs
of the Service and managing of an Army
household

By NANCY SHEA

\$2.50

(See Discount Offer, Page)

Some of the subjects covered:

Customs of the Service for the Bride
Business of the Army Household
Entertainment in the Army
Army Children
Change of Station
Service in Washington
Illness and Army Hospitalization
Death and Military Funerals

Order through

U. S. FIELD ARTILLERY ASSOCIATION
1218 Connecticut Ave., Washington, D. C.

Paste this on back of postcard

CHANGE MY ADDRESS

From

To

APO No. ,

NAME
PRINTED



For All Field Artillerymen!

DRILL AND CEREMONIES FOR FIELD ARTILLERY
(Complete)

Many times have Field Artillerymen wished they had texts on subjects written especially for them, so that they would not have to argue over ambiguous or only slightly-applicable paragraphs in regulations written primarily by and for doughboys. *Drill and Ceremonies* fills the bill for FIELD ARTILLERY. It resolves your doubts, settles your bets.

TABLE OF CONTENTS

- Dismounted Drill
- Service of the Piece
- Pistol
- The Motor Driver
- Equitation
- Driving and Draft
- Mounted Formations and Maneuvers
- Standards and Guidons
- Interior Guard Duty
- Ceremonies
- Individual Equipment and Tent Pitching
- Military Courtesy and Discipline
- Field Artillery Song
- Index

PRICE \$1.00, POSTPAID
(See discount offer on page 411)

THE FIELD ARTILLERY JOURNAL
1218 Connecticut Ave., Washington, D. C.

is required in the modern army of the United States, and the role played by the engineers, then discusses their organization, armament, equipment; special units for special jobs; how soldiers and officers are made and developed; the work in battle and behind the front; the part played by the Engineer Board and School; and the peacetime or civilian ("rivers and harbors") work of the Corps. Some of the illustrations appear also in Mr. Pratt's book, but of course the emphasis here is on engineers only.

This series of books should help all officers and men gain an understanding of the work and problems of their fellows and thereby promote more intelligent cooperation. A higher standard is found since the initial volumes appeared, but since some of them have been revised the entire group can heartily be recommended.

INSIGNIA OF THE SERVICES. By Paul Brown. Scribner's, New York, 1941. \$1.50.

A sound idea underlies this volume illustrating not only the insignia but the uniforms as well, of the army, navy, and marine corps. As published, there is considerable material still accurate and of interest to the many new service-connected families through the country. Enough changes have occurred, however, to warrant a new edition, including the new non-com designations, headgear, and branch and divisional insignia. New and sharper illustrations, omission of neckties from field uniforms, and corrected names for head coverings would also help. Meanwhile, Mr. Brown's book is the most interesting and inclusive on the subject that has come our way.

MECHANIZED MIGHT. By Major Paul C. Raborg. McGraw-Hill Book Co., New York, 1942. \$2.50.

The author served in the army before and during the first World War and has recently been one of the innumerable "military analysts" found in most radio stations and editorial rooms. With such a background he should have been able to produce an interesting and valuable book. This one, however, belies both its title and the subtitle *The Story of Mechanized Warfare*.

Major Raborg recognizes the importance of the late Major General Adna R. Chaffee, dedicating the volume to him. He dutifully traces the present-day tank to Hannibal's elephants. But in general he skips from topic to topic, presents a smattering of all weapons of all arms, describes the difference between strategy and tactics but then confuses them himself, gives the former organization of all kinds of divisions and the purposes and interdependence of their several parts, and relates long-winded tales from the Mexican border. His style of "I, me, my, and more I's" is somewhat trying on the reader. The catch-phrase title will probably attract some buyers, though.

Send a Year of the **FIELD ARTILLERY JOURNAL**

To Name.....
(Please Print)

Address.....

City..... State.....

Remittance for \$3.00 inclosed.

.....
(Signed)
.....

THERE IS ONLY ONE GUIDE



Complete

Everything an officer needs to know



Authoritative

Based on official publications



Up-to-Date

7th Edition, February 1942

THE OFFICERS' GUIDE

● The mass of War Department regulations, circulars, bulletins and other publications are sifted by experts, interpreted, "tied-in" with existing regulations and published in the OFFICERS' GUIDE with illustrations. The whole official story is there for every officer, plus authoritative advice on the many vexing unwritten Customs of the Service. A copious index allows you to put your finger on every officer problem from "Ability, professional" to "Zone of the Interior."

● To have the new OFFICERS' GUIDE is to know your way around.

488 Pages - \$2.50 - Illustrated

U. S. FIELD ARTILLERY ASSOCIATION
1218 CONNECTICUT AVENUE WASHINGTON, D. C.