

THE FIELD ARTILLERY JOURNAL

Volume XIX
1929

EDITED BY
JOHN M. EAGER
MAJOR, FIELD ARTILLERY, UNITED STATES ARMY

THE UNITED STATES FIELD ARTILLERY ASSOCIATION
WASHINGTON, D. C.

Contents

NO. 6 (NOVEMBER-DECEMBER)

Major General Fred T. Austin, Chief of Field Artillery	<i>Frontispiece</i>
General Austin to Retire in February	603
The Fork	604
By 1st Lieutenant P. Schwartz, O. D.	
The Field Artillery Association	610
Alexander Hamilton, Artilleryman	611
By Lieutenant-Colonel Walter H. Smith, F. A.	
Notes on the Air-Ground Maneuvers 5th Corps Area	624
By Brigadier-General H. M. Bush, Cmdg. 62nd F. A. Brig., 37th Div.	
All-Purpose Artillery Traction	644
By Major L. R. Cole, 6th F. A.	
What a Small Unit Can Do	658
War Bugs	660
By Charles MacArthur.	
Mechanization in Great Britain	675
By Major C. C. Benson, Cavalry.	
The Conduct of War	684
By Marshal Ferdinand Foch. Translated by Captain W. F. Kernan, U. S. Army.	
Great Commanders of the Far East	693
By Major W. H. Cureton, F. A. (D. O. L.)	
Foreign Military Journals: A Current Resume	707
National Guard Notes	725
Polo at Ohio State University	727
By Lieutenant John P. Eckert, F. A.	

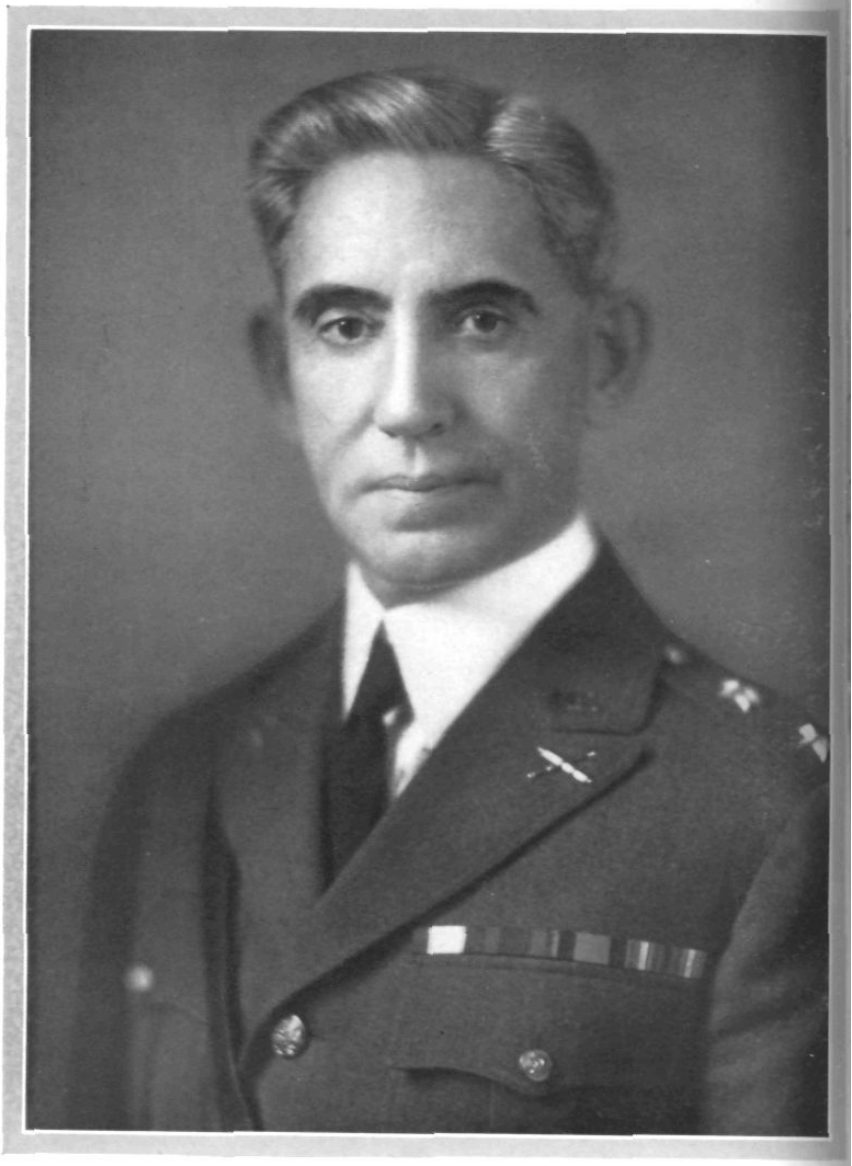

MAJOR GENERAL FRED T. AUSTIN, CHIEF OF FIELD ARTILLERY

THE FIELD ARTILLERY JOURNAL

VOL. XIX

NOVEMBER-DECEMBER, 1929

No. 6

GENERAL AUSTIN TO RETIRE IN FEBRUARY

It is with deep regret that we must announce that Major-General Fred T. Austin, our Chief of Field Artillery, recently applied for retirement on account of physical disability. After appearing before an Army Retiring Board, his application was approved, and on October 14th he was ordered to his home to await retirement. He will be placed on the retired list on February 15, 1930.

General Austin has been suffering severely from asthma, and in view of the fact that the climate of Washington is particularly unfavorable to this condition, after consulting medical advisers, he decided that it would be harmful for him to remain on duty in the War Department for another winter.

He was appointed Chief of Field Artillery on December 20, 1927, so when he retires he will have served more than two years as our Chief. During this tenure of office, which has also been a period of retrenchment for the whole army, General Austin has firmly insisted on the necessity of keeping active Field Artillery units supplied with sufficient personnel and means to enable them to function effectively. He has devoted a great part of his time to the study of new matériel and also to the defense of Field Artillery against low flying aircraft.

General Austin's thorough understanding of conditions throughout the Field Artillery, based on many personal inspections and contacts, causes his retirement at this time to be felt as a keen loss to all officers and enlisted men of our arm.

THE FORK

BY FIRST LIEUTENANT P. SCHWARTZ, O.D.

THERE have appeared recently in the FIELD ARTILLERY JOURNAL, in the U. S. Naval Institute Proceedings, and in the Coast Artillery Journal, discussions relating to the dispersion connected with gun fire. These discussions indicate a certain amount of difference of opinion on the subject.

One of the phases treated is the shape of the probability curve for long range fire. Another phase is the difficulty in using the probable error in scoring or adjusting artillery fire.

It is proposed to discuss briefly the nature of the probable error from the point of view of the accuracy with which this quantity can be predicted from the firing tables or from previous firings, for use in artillery fire.

Let us examine the firing tables for any particular gun. Assume that the following figures are obtained from the firing tables. Range 5000 yards, elevation 200 mils, time of flight 14 seconds, change in elevation for 100 yards change in range 3.4 mils, field probable error in range 40 yards, and fork 4.7 mils. With the gun and ammunition for which the firing tables are prepared, set the gun at 200 mils elevation and fire one round. Unless some very careless mistake has been made or the gun is very old, it is probable that the range obtained will not be much less than 4500 yards nor much greater than 5500 yards, even though meteorological corrections may not have been made. A deviation of 10% in range may be considered to be a large deviation and one which does not occur very often.

Assume that shrapnel is being fired, and that in this particular case, due to absence of a fuze setter, the 21-second combination fuze is set for 13 seconds by a fuze wrench. A round fired at the proper elevation with fuze setting 13 seconds will give a burst in air which will probably not be much less than 11.5 seconds, nor much more than 14.5 seconds. Here again a deviation of approximately 10% may be considered to be a large deviation, and one which is not to be expected to occur very often.

THE FORK

If it is desired to increase the elevation so as to increase the range by 200 yards, an increase of 6.8 mils, or 2 times 3.4 mils will cause the range to be increased by this amount, or by an amount which will not differ from 200 yards by much more than, at most, 25 yards, or approximately 10%.

Now, suppose that the percussion precision method of adjustment is being employed, and it is desired to make use of the fork as a unit of length in making corrections. This fork from the firing tables is 4.7 mils in elevation, which is equal to the change in elevation corresponding to 160 yards, or 4 times 40 yards, which is one probable error. The question now to be studied is as follows: What is the accuracy with which the fork or corresponding four field probable errors is known? Suppose 4.7 mils is used as a fork, the target is finally properly bracketed in trial and improvement fire, and fire for effect is conducted at the proper elevation by firing 24 rounds at the same elevation and from the same gun. Would an examination of the points of fall of these 24 shots show that the developed probable error was actually or nearly 40 yards, and, therefore, the fork of 4.7 mils correct within approximately 10%? This 10% was found to be the greatest deviation from firing tables value to be expected in the case of the elevation, times of flight, and change in elevation for a certain change in range.

It is proposed to show by examination of the records of proving ground firings that the probable error and therefore the fork varies considerably from the firing tables value. Figure 1 is a plot of the 50% zone, or twice the probable error, developed in firing the 75 mm gun M1916 at the proving grounds. The records of firing approximately 875 rounds were used in preparing this plot.

In an extensive firing of the 155 mm howitzer at the proving ground the following results were obtained. The firings were made at 32° elevation, each value of the probable error being based on a group of 20 rounds.

THE FIELD ARTILLERY JOURNAL

PROBABLE ERROR IN RANGE-YARDS

Day	Zone	I	II	IV	V	VI	VII
First		58	22	54	57	57	36
Second		35	37	64	60	43	61

FIGURE 1

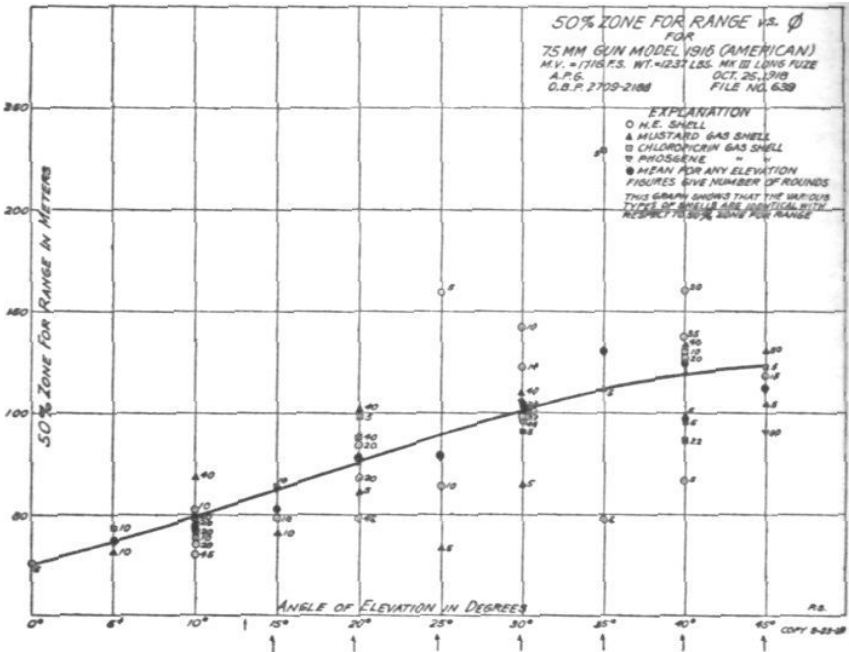

Another example of varying probable errors is shown in the results of firing a large number of groups of rounds from the 155 mm gun on different days. One set, fired at about 16,000 yards range, gave the following results:

Number of rounds in group	Probable error in range yards	Number of rounds in group	Probable error in range yards
19	88	16	96
20	68	20	48
16	76	20	68
10	72	20	88
9	96	20	96
18	44	20	52
20	100		

THE FORK

Another set, fired from the 155 mm gun at about 15,000 yards range, gave the following results:

8	72
16.....	144
9	84
9	88

The above data indicate clearly that the probable error, and therefore the fork, varies considerably and that any average value which is tabulated in the firing tables is subject to large errors which may be considerably greater than 10% and which may even reach 50% or more.

As an illustration of how the writer conceives that the probable error varies, consider the following: Suppose that a self-contained horizontal base coincidence type of range finder is used to measure the distance to a stake on land or out on the water. Let the distance be determined by averaging ten readings. Let a trained observer take a set of readings on a clear day and then follow it by a set of readings on a rainy or foggy day. The average on the clear day will probably not differ very much from the average on the foggy day. However, it is to be expected that on a clear day the observer's readings will cluster closely about the average value because coincidence will be obtained without difficulty and estimation. The readings may be 4950, 5020, 5060, 5030, 4940, etc. On a foggy day coincidences will not be obtained so easily, and the observer will be compelled to estimate the conditions of coincidence; there will result a series of readings which do not cluster closely about the average value. These readings may be 4500, 5400, 4700, 5000, 5300, etc. The difference in clustering of observations on a clear and foggy day is similar to the difference in clustering of points of fall of shots. In firing, the cause of the difference in clustering may not be due to difference in visibility alone; it may be due to any change in conditions which affects the mount, the gun, the ammunition, the gun crew, or the atmosphere. This difference in clustering corresponds exactly to the difference in probable errors which may be expected in firing at different times and under different conditions. If weather conditions do not vary materially, if the mount and gun are kept in good condition, if the ammunition is held at a

THE FIELD ARTILLERY JOURNAL

uniform temperature during the firing, if the firing is conducted with care, and if the personnel of the gun crew remains the same, the variations in probable error can be kept at a minimum.

There are other quantities listed in the firing tables which do not have a high order of accuracy. For example, the effect of powder temperature on muzzle velocity may be considered. It is undoubtedly true that increasing the temperature of the powder increases the muzzle velocity. However, the exact magnitude of this increase is considerably in doubt. The formula on which this correction is based gives values which differ from all other similar values. It says that for a change from 0° to 10° in powder temperature the velocity changes by about .25%, whereas from 90° to 100° the velocity changes by about 1.6%. A change from 0° to 10° in air temperatures causes practically the same change in range as a change from 90° to 100° . A change in air density from 90% to 92% causes practically the same effect as a change from 108% to 110%. It is understood that the Navy uses a formula which gives approximately 2 f. s. change per $^{\circ}\text{F}$ change in powder temperature, and that the French use .1% change in velocity per $^{\circ}\text{C}$, or .06% per $^{\circ}\text{F}$. Some such simple formula would be more reasonable and would be just as accurate as the present one.

Other quantities listed in the firing tables may also be mentioned as having a high order of inaccuracy, namely air temperatures or elasticity of air effect on range, and weight of projectile effect on range.

In spite of these criticisms, the U. S. Army firing tables may be considered to be as accurate as any firing tables published by either the Navy or any foreign countries. The inaccuracy in the powder temperature effect, air temperature effect, and weight of projectile effect, may all be attributed to lack of information which is being sought at present through research at the proving ground and elsewhere. No foreign country has better information on these subjects than we have, nor is any other country making any greater efforts to secure this information than we are.

It must be realized that the firing tables constitute a tool which is prepared by the Ordnance Department and furnished

THE FORK

to the using branches to help in firing. Artillery can be fired like shotguns and results will be obtained, but the results will, in the long run, not compare with those obtained with the help of firing tables. To use this tool properly it is necessary that the user have some notion of its limits of accuracy. No one would think of using a common celluloid protractor in setting the elevation of a 155 mm howitzer; a gunner's quadrant, accurate to the mil or tenth of mil would undoubtedly be used. But this protractor could be used quite accurately in some other problems on the drawing board, where an accuracy of several mils was sufficient. If one were in doubt as to the accuracy of a pair of one-inch micrometer calipers, no one would think of seizing the nearest wooden foot rule and using one of the inch graduations to check these calipers. An accurately measured gauge supplied by the makers of the calipers would be used. Similarly, one cannot blindly apply firing tables values to gun fire and hope to get the best results. It is necessary to have some idea of the limits of accuracy of every quantity in the tables in order to make use of it properly.

The probable error and the fork are quantities which can cause the artilleryman considerable worry because of their behavior. The firing tables give the best average value of the fork. The upper and lower limits of variation of the fork have been shown to be considerably different from the average value. Suppose that a battery commander makes use of a firing table's value of the fork which happens to be smaller than the fork (four probable errors) actually being developed by the gun being fired. He will then unnecessarily lengthen the time spent in trial fire as well as increase the number of rounds. This will be true because he will endeavor to obtain a bracket which is smaller than can ordinarily be obtained in the same time and using the same amount of ammunition knowing the correct value of the fork. Similarly, if the firing tables fork is larger than that actually being developed by the gun being fired, a bracket larger than that which the battery commander really should obtain will result, and considerable effect may be lost in the firing.

THE UNITED STATES FIELD ARTILLERY ASSOCIATION

In compliance with Article VII, Section I, of the constitution, notice is hereby given that the Executive Council has fixed 4:30 p. m., Wednesday, December 11, 1929, as the time of the annual meeting of the Association to be held at the Army and Navy Club, Washington, D. C.

The business to be disposed of will be the election of eight members of the Executive Council. Of these, four are to be elected from the Regular Army, two from the Organized Militia (National Guard) and two from the Field Artillery Section of the Officers' Reserve Corps.

Section I, Article VI, of the constitution reads as follows:

"The Executive Council shall be composed of nine active members, five of whom shall be officers of the Regular Army, two officers of the Organized Militia and two officers of the Field Artillery Section of the Officers' Reserve Corps, to be elected biennially for a term of two years by a majority vote, in person or by written proxy of the active members."

The member of the Executive Council whose two-year terms expire this December are the following:

Major-General Fred T. Austin, U. S. Army.

Brigadier-General Andrew Moses, U. S. Army.

Colonel Harry G. Bishop, U. S. Army.

Colonel Samuel G. Barnard, New Jersey National Guard.

Colonel Ernest R. Redmond, Massachusetts National Guard.

Colonel Leroy W. Herron, Reserve Corps.

Colonel Robert Bacon, Reserve Corps.

Lieutenant-Colonel Donald C. Cubbison, U. S. Army.

In view of the fact that the constitution requires fifty per cent of the members in the United States to be present in person or represented by written proxies to constitute a quorum, it is urgently requested that the return post cards which have been mailed to the members of the Association be filled out and mailed to the Secretary of the Association.

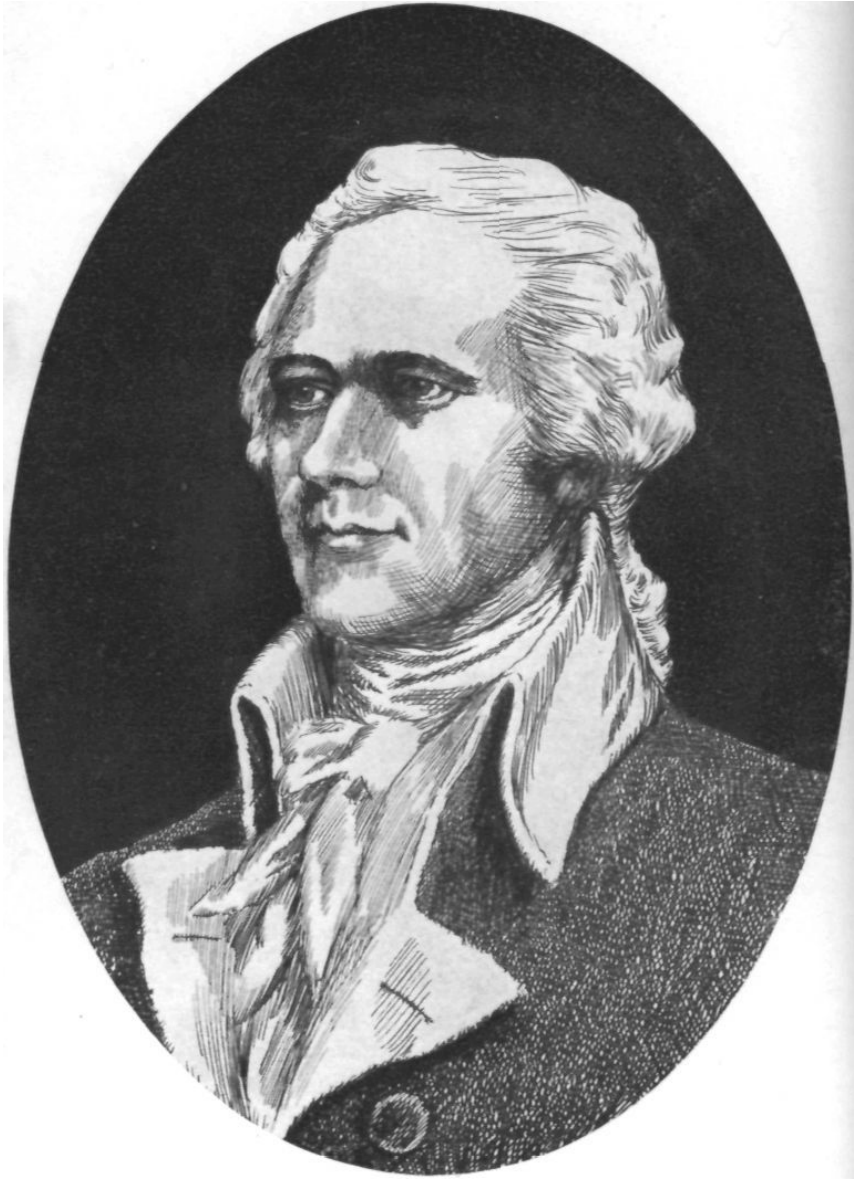

ALEXANDER HAMILTON. AS A BATTERY COMMANDER HE DISTINGUISHED HIMSELF EARLY IN THE AMERICAN REVOLUTION

(Drawing by Rex Chandler, 1st Lt., F. A.)

ALEXANDER HAMILTON, ARTILLERYMAN

BY LIEUTENANT-COLONEL WALTER H. SMITH, F. A.

Illustrations by Rex Chandler, 1st Lieut., F. A.

The biographers of Alexander Hamilton have given scant attention to his career as a soldier, and therefore we are apt to overlook his important service to our country as an artilleryman of the Revolution. His accomplishments in the field of politics and government were so notable that they have overshadowed his less conspicuous performances in bivouac, on the march and in battle. The whole story of his life is fascinating, but no part more so than that of the youthful artillery commander. Considering his military career in the light of his opportunities for training and his youth while in the army and also in comparison with other military figures of America and of his time, it is well within the purview of reason to believe that, had circumstances been more favorable to him as a soldier, he might have been as great in war as he was in peace. He possessed to a marked degree those qualities which make a great commander, physical and moral courage, a keen and logical mind, the ability to grasp a sound idea and to carry it to a conclusion, physical vigor, loyalty and a personality that drew others to him in a common effort. Although his contribution as a soldier to the cause of the Colonies during the early part of the Revolution was important and was made at a time when most needed, nevertheless its greatest moment is in the fact that it was the youthful captain of artillery who first attracted the attention of Washington and thus initiated a relationship of tremendous consequences in the affairs of our country.

Hamilton was born in the West Indies in 1757 and in his fifteenth year came to New York City to be educated. Although he was of foreign birth and many of his friends and instructors in college were loyalists, and although his tender years would in the nature of things have precluded him from having strong convictions on political subjects, he promptly espoused the cause of the Colonists with all the enthusiasm of a new disciple. Foreseeing that the declaration of resistance and the raising of militia

THE FIELD ARTILLERY JOURNAL

organizations by the Provincial Congress would lead to war, he set himself to work studying military books and joined a volunteer corps called "Hearts of Oak" commanded by a former British officer. This organization was composed of young men of the city who sought military training in view of the approaching war. It was probably the first progenitor of the Officers' Training Camps of our day.

At this time Hamilton, in spite of his youth, had attracted considerable attention in the colony by his political pamphlets and speeches in opposition to the course of the British Government in the colonies. But his activities had not been only verbal. On several occasions at the risk of his person and, what was of more concern to him at the time, of the good will of the Tory baitors, Hamilton, whose orderly mind revolted against excesses of any kind, violently opposed the actions of rioters in the city. His activity at that time was also evidenced on an occasion when a group of citizens were moving some cannon from the Battery at the south end of Manhattan. They were approached by a boat from the British man-of-war Asia, upon which the citizens fired, believing it was coming to oppose the moving of the cannon. This drew fire from the Asia, "during which Hamilton, who was aiding the removal of the cannon, exhibited the greatest unconcern, although one of his companions was killed by his side." Thus he was conspicuous in the first violent resistance to the Crown in the colony.

On January 6, 1776 the New York Provincial Congress passed a resolution raising an artillery company for the defense of the colony.² Hamilton applied for command of the company. There being some doubt as to the qualifications of a youth of nineteen years, he was given an examination. In the records of the Provincial Congress of March 14, 1776 appears the following: "A certificate of Stephen Badlam, a Captain of Artillery, was read and filed. He thereby certifies that he has examined Alexander Hamilton and judges him qualified to command a company of artillery. Ordered: That the said Alexander Hamilton

¹Letter of Colonel Troup to Colonel Pickering.

²This company is now Battery D, 5th F. A., the oldest organization of our regular army.

ALEXANDER HAMILTON, ARTILLERYMAN

be, and he is hereby appointed Captain of the Provincial Company of the Artillery of this Colony."

He was then a student at King's College (now Columbia University). At about this time Lord Stirling, commander of the Continental Troops in the colony requested Elias Boudinot, who had been Hamilton's first tutor in New York, to invite Hamilton to become a member of his staff. Boudinot replied: "Mr. Hamilton has already accepted the command of a company of artillery and is therefore deprived of the pleasure of serving your lordship as brigade major."

Hamilton entered upon his task of recruiting and training his company with the enthusiasm and energy that characterized all of his efforts. He spent on his company the last of the funds received from his family for his education. His interest in his men, his appreciation of merit and his eagerness to reward it are shown by a letter to the Congress in August in which he recommends promotion of deserving officers in succession and more specifically adds, "I would beg the liberty warmly to recommend to your attention the first sergeant of my company—a man highly deserving notice and preferment. He has discharged his duty in his present station with uncommon fidelity, assiduity and expertness; he is a very good disciplinarian, possesses the advantage of having seen a good deal of service in Germany, and has a tolerable share of common sense. In a word I verily believe he will make an excellent lieutenant, and his advancement will be a great encouragement and benefit to my company in particular, and will be an animating example to all men of merit to whose knowledge it comes". Sergeant Thompson was made a lieutenant, was later advanced to the grade of captain-lieutenant and was killed at the head of his men at the Battle of Springfield. Following Hamilton's suggestion the Congress passed a resolution providing for "promotion of such privates and non-commissioned officers as should distinguish themselves".

Another evidence of his solicitude for his men and also of the respect the Congress held for his views may be found in his letter recommending that his company be placed on the same status as to pay and allowances as the Continental Artillery and

THE FIELD ARTILLERY JOURNAL

that frocks be issued to his men in order to save their uniforms. The same day the Congress resolved that "the artillery company of the said Alexander Hamilton receive and be allowed the same pay as the Continental Artillery and that the said Alexander Hamilton receive ten shillings for every man he has or enlists, not exceeding 100 men, and that each man of the said company be allowed a frock as bounty".

He drilled his men in the fields which are now City Hall Park, New York City and Custis (Washington's stepson) in his memoirs relates that General Greene, whose friendship for Hamilton later became very warm and to whom the latter returned a friendship equally as generous, watching the evolutions of the company, was so impressed with its commander's skill that he made his acquaintance and soon afterward commended him to Washington.

The following is the return of the company on June 29, 1776.

Return of the New York Company of Artillery in the Service of the United Colonies
Commanded by Captain Hamilton

	Captain	Capt. Lieuts.	Lieutenants	Sergeants	Corporals	Bombardiers	Gunners	Drums & Fifers	Matrosses	Total
Present fit for duty	1	1	3	3	3	3	4	3	61	82
Sick, present						1	2	1	4	8
Sick, absent				1						1
Prisoners									2	2
Total	1	1	3	4	3	4	6	4	67	93

New York June 29th, 1776.

At this time the company was armed with 12 pounder and 24 pounder guns.

Its commissioned and non-commissioned personnel as of August 31, 1776, was as follows:

Alexander Hamilton, captain; James Moore, captain-lieutenant; James Gilliland, first lieutenant; John Bane, second lieutenant; Thomas Thompson, third lieutenant; Samuel Smith,

ALEXANDER HAMILTON, ARTILLERYMAN

Richard Taylor, James Deasy, sergeants; Robert Barker, John Stokes, Martin Johnson, corporals.

During June and July the company was at Fort George at the southern end of Manhattan Island and on July 12th fired its first shot at the enemy when two pieces opened on two British ships in the harbor.

Hamilton was first seriously engaged with the enemy at the Battle of Long Island. In August Washington sent about half of his 18,000 poorly equipped and even more poorly trained men in the vicinity of New York City to prepare for defense and to



FIRST MEETING OF WASHINGTON AND HAMILTON AT HARLEM HEIGHTS

THE FIELD ARTILLERY JOURNAL

garrison a position at Brooklyn Heights. On August 22nd General Lord Howe, the British Commander, left Staten Island with about 20,000 seasoned troops and landed at Gravesend Bay, Long Island. On the 27th he attacked the Colonial troops at Brooklyn Heights from the south and east. The Americans were badly beaten. During the battle Hamilton's company was sent across the East River and acquitted itself with credit, a fact which was notable in an action in which there was so much that would have been discreditable on the part of better trained troops. On the night of August 29th Washington executed a skillful withdrawal of his troops across the East River to Manhattan. Thence the larger part of his command retired to Harlem Heights at the upper end of the island leaving Putman in command of the troops in the lower part. Hamilton's company at this time belonged to Scott's brigade which was stationed at what is now the east end of 15th Street, with the mission of preventing the British from landing at that place. On September 15th Howe crossed the river and landed at the present 34th Street. On the approach of the British, the Militia stationed at this place were stricken with terror and fled without firing a shot. This defection of the Militia exposed the line of retreat of Scott's brigade and of all the remainder of Putman's division. However they succeeded in retreating up the west side of Manhattan and in joining the main body at Harlem Heights. During this retreat Hamilton's artillery was a part of the rear guard. He handled his guns with skill and courage, losing one gun and his baggage.

He then placed his guns in position at the Harlem Heights line. "At this place," according to John C. Hamilton, his son, "Hamilton first attracted the observant eye of Washington, who, on the inspection of the works he was engaged in throwing up, entered into conversation with him, invited him to his marquée and formed a high estimate of his military capacity." Other historians however affirm that Hamilton's skill had been called to the General's attention previous to this occasion.

The Battle of Harlem Heights was a local affair in which it appears that Hamilton was not engaged.

ALEXANDER HAMILTON, ARTILLERYMAN

Howe moved the greater part of his command up the East River and on October 16th landed at Throggs Neck in Westchester County at the northwest end of Long Island Sound with the purpose of striking the Harlem Heights position in rear. Washington had foreseen this movement and promptly withdrew his troops to White Plains, except the garrison of Fort Washington at a short distance north of the Harlem Heights position. Washington was forced by the Continental Congress against his judgment and in spite of his protests to continue the occupation of this post.

Howe attacked the Americans at White Plains on October 28th. Hamilton fought his guns with notable skill during this battle. "Concealed by the heavy foliage of trees and shrubs Hamilton planted two field pieces on a ledge of rocks and commanded the place where the enemy were at work erecting a bridge across the Bronx. He opened fire, killing several of the enemy and throwing the Hessians into confusion. The British rushed up the hill to capture the guns but were driven back. A second charge was more successful and the brigade and battery were forced to retire."¹ After this battle Washington moved to North Castle in Westchester County and shortly thereafter crossed the Hudson and occupied Hackensack, New Jersey.

On November 16th the British



¹A Brief History of the 8th Battery, U. S. Field Artillery, by General William L. Kenly.

THE FIELD ARTILLERY JOURNAL

captured Fort Washington with its garrison of about 2600 men. "The fall of that fortress, which sealed the fate of the City of New York, and cut off so large a portion of the army, awakened all the soldier's spirit of his (Hamilton's) breast, and, after a careful observation of the post, he volunteered to General Washington to storm it, saying, that if he would confide to him an adequate number of men, one-half under the command of Major Stevens, the residue of himself, he would promise him success. But the small number of troops, and the position and strength of the enemy forebade this gallant enterprise, to which Hamilton was encouraged by a knowledge of its defenses, and by the ease with which it had fallen."²

Hamilton and his company were a part of the rear guard of Washington's army that retreated, followed by the British, through Newark and New Brunswick to Princeton. By this time the army, by reasons of expiration of terms of service, desertions and sickness, had become reduced to 3000 poorly armed, half-clothed and thoroughly discouraged men. The retreat was undisturbed as far as New Brunswick. There, as the rear of the American column was crossing the Raritan River, the van of the British column arrived. Hamilton, placing his guns in position on an eminence commanding the crossing, opened a spirited cannonade on the British and assisted in preventing their crossing. Custis relates that Hamilton's conduct on this occasion was observed by Washington, who was charmed by the brilliant courage and admirable skill of the young captain of artillery who directed the fire of his battery against the enemy's advancing columns that pressed upon the Americans in their retreat.

Washington's army entered Princeton on the first day of December. An observer of that day states: "Well do I recall the day when Hamilton's company marched into Princeton. It was a model of discipline; at their head was a boy, and I wondered at his youth, but what was my first surprise, when struck with his diminutive figure, he was pointed out to me as that Hamilton of whom we had already heard so much." This description of Hamilton's company was a striking contrast to that which would

²Life of Hamilton by John C. Hamilton.

ALEXANDER HAMILTON, ARTILLERYMAN

have applied to most, if not all, of the other units of the American army. Such was the condition of Washington's troops at the time that he felt impelled to place the Delaware River between himself and his pursuers. He crossed the river west of Princeton destroying every boat that could be found within miles. Howe arrived at the crossing the evening of the same day, but was unable to cross with the means



at hand. He, therefore, decided that Washington's army had become so ineffective that it was not worth while to continue the pursuit. Accordingly, he placed his army in winter quarters over an extended front with its center at Trenton and he and Cornwallis left for New York to enjoy the glory of victory.

Washington, having received reinforcements which raised his little army to about 6000, decided to profit by the light-hearted fashion in which the British were guarding their camps. He planned to cross the Delaware in three columns (one commanded by himself) and to attack Trenton on Christmas night. The night was bitterly cold and in the river were huge masses of floating ice. Before his own column commenced its crossing he learned that the other two columns on account of the weather had abandoned the enterprise. Undaunted, he started his 2500 men across. The crossing required more than ten hours and, that accomplished, there was a nine-mile march in a snow storm

THE FIELD ARTILLERY JOURNAL

before reaching his objective. If the hardships and hazards were great the victory was many times greater. The Hessians were completely taken by surprise and surrendered one thousand in number with little resistance. Trevelyan describing Hamilton's part in the battle states: "Colonel Knox had placed his guns in line as fast as they arrived at the cross roads, and gave them the range himself; and the Americans had pushed forward so briskly that Alexander Hamilton—who marched with the reserve, and was therefore the last to unlimber—discharged shell with deadly effect into the leading company of the Von Lossberg regiment as it emerged from Church Alley."¹ The victory, small as to numbers, was tremendous as to effects. It was Washington's first success and revived the expiring hopes of the American people.

Cornwallis now hastened back from New York to Princeton and from there sent about 8000 men to attack Washington. The latter retired across the Assanpink Creek, which flows generally westward into the Delaware at a point just south of Trenton. This crossing was completed about dark in the face of the pressing British. The British commander decided to cross the next morning and attack the American right flank, driving them back upon the Delaware. But during the night Washington, leaving behind a small body of troops to conceal his movements by keeping up a lively semblance of camp activity, slipped away to Princeton and at daylight attacked three regiments that Cornwallis had left at that place, just as they were moving out to reinforce the main body at Trenton. The surprise was complete and the British routed. Says Trevelyan: "An attempt at resistance was made at the College. Even in that quarter there was little bloodshed, but some profanation; for young Alexander Hamilton, with the irreverence of a student fresh from a rival place of education, planted his guns on the sacred grass of the academical campus, and fired a six-pound shot which is said to have passed through the head of King George the Second's portrait in the Chapel."¹

After the battle Washington moved north to Morristown and established his headquarters for the remainder of the Winter.

¹The American Revolution by Sir George O. Trevelyan.

ALEXANDER HAMILTON, ARTILLERYMAN

There Hamilton's career as an artilleryman came to an end. On March 1, 1777, he was appointed aide-de-camp to the General with the grade of lieutenant colonel. His age was twenty years and one month.

It would be interesting to follow Hamilton's story through the remainder of his military life, but we are concerned here with only what is of special interest to the artilleryman. He often expressed a strong preference for the artillery, but his later military service was in other fields.



Concerning Washington's headquarters at Morristown, Trevelyan writes: "The way of life in Washington's household was simple in the extreme, but not austere, and the very reverse of silent; for he loved to surround himself with young people who talked their own talk, and amused themselves in their own fashion. The three beautiful daughters of Governor Livingston resided with their aunt, Lady Stirling, and their cousin, Lady Kitty Duer, in a fine old Manor-house not far from Morristown; and there was no dearth of wit and gallantry among the young fellows who, with Alexander Hamilton as their leading spirit, were members of what, in the military parlance of the day, was known as "the General's family."¹

While no one can rightfully claim that Hamilton, as Washington's aide, shaped the latter's policies, nevertheless many of

¹The American Revolution by Sir George O. Trevelyan.

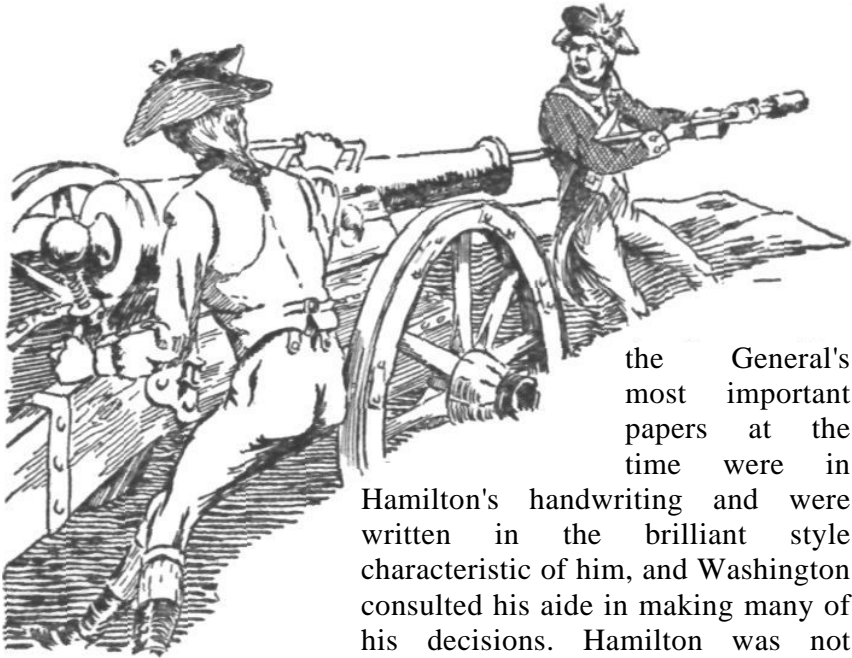

the General's most important papers at the time were in Hamilton's handwriting and were written in the brilliant style characteristic of him, and Washington consulted his aide in making many of his decisions. Hamilton was not happy as a staff officer and chafed under the conviction that his proper place was in command of troops. After repeated requests his wish for a command was finally gratified during the last campaign of the war. His distinguished gallantry at the Siege of Yorktown, where he commanded a "corps of light infantry" composed of several battalions which he led in the last assault of the Revolution, fully justified Washington in giving him the place of honor in that action.

He resigned from the army after the war and then followed that part of his life which has been so often told in history. But some twenty years after the war his name again appears on the roll of the army—this time not as a captain of artillery but as a major general, although he had been out of the service since the days of Yorktown. This was in 1799, when war with France appeared to be at hand and when, to meet this emergency, Washington had been selected as Commander-in-Chief. Washington agreed to serve only on the conditions that he should exercise no active command until the army should take the field and that he should select the officers of highest rank in the army and his staff.

ALEXANDER HAMILTON, ARTILLERYMAN

He chose Hamilton as next in rank to himself. On his death in December of that year Hamilton became Commanding General of the Army, which post he held until his resignation in June of the following year, the menace of a war with France having passed.

Although his fame lies in other fields, he always had a strong predilection for things military and a stout conviction that he had within himself the genius of military leadership. This conviction was born of a deliberate self analysis and was doubtless correct as were almost always the deductions of his brilliant mind.



NOTES ON THE AIR-GROUND MANEUVERS, 5TH CORPS AREA

BY BRIGADIER-GENERAL H. M. BUSH, COMDG. 62ND F. A. BRIGADE, 37TH DIV.

AS THESE notes are written by a field artilleryman for field artillerymen, it is hoped that those who may see in what is herein written vile and biased partisanship as well as total blindness to the merits of others will not be too drastic in their condemnations, and will remember that all cooperation should not come from the auxiliaries alone in each and every case. It is fairly easy to climb a forty-foot ladder, but one has to have help to get it in position to climb.

These maneuvers were preceded by two war games worked out at Fort Hayes first and then at Fort Benjamin Harrison during the months of January, February and March.

The lessons and experiences learned in the war games were translated into the plan and orders of the maneuver. The improvement that those of us who participated in both noted in practically every detail speaks well for the training and skill of the officers composing the "Team".

So much was done with the \$30,000 available that, were it not for the instructive value of criticism, it would be invidious to make any at all.

The difficulties and shortcomings, which may hereinafter be touched upon, should not be regarded as mere bellyaching, but rather as inviting attention to points the change or improvement of which would tend to make a similar exercise more valuable.

The notes are the result of thoughts and impressions of minor actors in the game put into writing, some three weeks after the maneuvers, and only after considerable thought had been given to them.

The maneuver in general was that of the standard Red (east) and Blue (west) states being at war. The Blues being the aggressors and slightly stronger numerically at the outset seek to capture the Red capital (Columbus, Ohio) and cut off the Reds from the industrial section of their state (Northeastern Ohio).

NOTES ON THE AIR-GROUND MANEUVERS

The Blue First Army based on Dayton (Fairfield) attacks with two Corps (I and II).

The I Blue Corps consists of the 37th, 38th and 84th Divisions in the line with one division in reserve.

The II Blue Corps consists of the 83rd and 100th Divisions in the line and the 10th in reserve.

Of these, the 37th, 38th, 83rd and 84th Divisions had skeletonized staffs.

The staffs of Army and Corps were made up from available officers of the Regular Army, National Guard and Reserves, all skeletonized. Army and Corps troops existed only on paper, without even officers to represent them. The Air Corps of the Army (regular) was about equally divided between the Reds and the Blues.

The Artillery Brigade Commanders of the divisions were each allowed one officer and an assistant and (at times) a clerk. In the writer's case he was materially assisted by one of his own staff, who was detailed as Division Engineer, and a regimental P. & T. Officer, who vounteered for a couple of days. Even with this unofficial help the load was pretty heavy.

According to the Tables of Organization, there were two regiments of horse-drawn 75's in the Divisional Artillery Brigade. Under the conditions of the maneuver the average command consisted of five regiments; four 75s and 155 Hows., and, in addition, on the last day, the Brigade Commander found himself with a regiment of 12-in. trench mortars. In addition to the artillery each division had a balloon attached to it and four observation planes were available in the Corps. There was no divisional air service (theoretical or actual).

Under the maneuver conditions there were no actual regimental or battalion commanders, although we were asked to spot our positions down to and including batteries. As physical reconnaissance was confined solely to the roads, this requirement was not possible of fulfillment and was modified to battalion areas. This gave us a total of five regimental commanders, eleven battalion commanders and two ammunition train commanders, whose problems and work had to be performed at Brigade by the skeletonized staff. However, it was not quite as hard as it looked, as we got

THE FIELD ARTILLERY JOURNAL

rid of the colonels by assuming they were with the infantry brigades or, in the case of the howitzers and attached brigades, with us, and the several battalions were moved on our own checker board, with nary a kick or complaint from any of them, except what came through the "canning factory".

The writer has taken part in a considerable number of CPX problems and has always been surprised and rather chagrined to find that practically nothing "canned" came through concerning the artillery of the type that our own experience and requirements would indicate. This was true during the preliminary war games and the lack of them was commented upon at the time. It was, therefore, quite gratifying to find that a fairly good percentage, in comparison, of typical messages were included in the "canned goods" in this maneuver.

Of course, we had a message center. The personnel came from Co. "A," 11th Infantry, and was very well trained and efficient. They did their level best to deliver the goods; but they were hamstrung by the basic weakness of the system as far as operations messages are concerned. The system may operate very well for administrative messages, reports, etc., which can be handled on a schedule, but it breaks down utterly and completely when it comes to the rapid fire work of operations.

Having given the bare outline of the set-up, let us now take up the various phases of the mechanics of the maneuvers and discuss, as briefly as possible, some of the high spots of interest. Always remembering that this is a one-sided argument and that such criticism as may appear, is intended as constructive and a presentation of the case of the field artilleryman.

If there is one thing that has been drilled into the field artillery commanders and their staffs more than anything else, it is *cooperation*. With this idea firmly fixed in one's mind, it is somewhat disconcerting to go into a staff conference and find that to be permitted to give the utmost of cooperation one has to fight for even recognition.

As it will frequently happen, the Division Commander has been associated with his Gs and immediate staff during both the armory and field training periods, while the artillery has been working elsewhere. The staff proper have worked and studied

NOTES ON THE AIR-GROUND MANEUVERS

together until they have developed a beautifully working machine. Then the Artillery Brigade Commander is injected into the scene. His opinions and advice may not be worth a broken halter strap, but he is there to work into, although he somehow jars, the perfect picture. What more natural than for the Gs to forget that he must know and appreciate the plan even in some of its smaller details in its very earliest stages! On one occasion it took a twenty-mile fast drive to Corps and back for the Artillery Brigade Commander to obtain some information, vital to his work, that one of the Gs had missed getting. If the Brigade Commander had been called for the conference that time and effort would have been saved. If there is to be an artillery advisor to the Division Commander that officer must be kept in position to render that advice from his own knowledge of the situation and not be compelled to rely on the memory of one of the Gs, whose mind is necessarily on other things.

Unless the Gs fully appreciate the limitations and necessities of the Field Artillery there is bound to be lost motion and delay in the handling of situations. Under actual conditions the Artillery Information Service, as well as the brigade communications, will keep the brigade pretty well informed as to front-line conditions and also as to ammunition supply. But under the artificial conditions of the CPX plus the interposition of the message center, the amount of artillery information coming in is pretty strictly limited. The "canned messages" do not, judging from experiences other than this one under consideration, give much consideration to the artillery. In the war game in January there was only one direct message received on one night by the Field Artillery. Other exercises have been equally disappointing. In the May maneuver the artillery "canned stuff" was somewhat more in evidence, but it was not in proportion to what the eleven battalions and five regimental headquarters would have sent in under actual conditions.

There is always the possibility that communications with a certain liaison officer are broken at a critical moment and a dent develops in our line. This is detected by an air observer, who hurries it to Division and drops the message. Message center delays it, as a matter of course; it goes to the Chief of Staff,

THE FIELD ARTILLERY JOURNAL

who hands it to G2 or 3, here it is delayed until either or both of them have put it on their maps and entered it in their journals; then it filters through to the artillery. Which is more important, that the infantry up in that particular section of the front should be given assistance as quickly as possible, or that the Gs should have it on their maps or in their reports? The answer is obvious, perhaps, but we had the experience of seeing dropped messages arrive giving the exact position of our front line elements and then through the delays mentioned above, we get the contained information after an argument (in some cases) only to find that our own "canned stuff" had preceded it by almost exactly the time spent by the message in traveling from its arrival on the ground to our desk. (The lines moved every hour.) Had the situation in any part of the line been as described above, the help we could have given would have been unnecessarily delayed. This and several more similar kinks in the perfection of our mutual cooperation served as excellent training and I will venture to say will never come again in the same combination of staffs. It is better to learn these lessons when lives are not the price of errors and faulty coordination.

In our relations with G3 there would occasionally be instances where, in working out an order, we both would designate the same point or area for positions or locations. Sometimes these got through without detection, but in all but one or two cases they were caught. Invariably G3 changed his dispositions. It is conceivable that the orders with the conflicts undetected could get out to the troops; and, depending a good deal on the common sense and spirit of cooperation existing among the troop commanders concerned and on the spot, they would have been adjusted there. The matter is spoken of here as it involves the same principles as to priority that is already accorded the artillery on the roads. As such cases would ordinarily affect the tanks or the reserves of smaller units, the particular position would not affect them, whereas it might be of very great moment to an artillery unit. We have had the experience of an infantry brigade commander objecting to the presence of artillery units in his area that were not directly supporting his brigade; but that is quite unusual.

NOTES ON THE AIR-GROUND MANEUVERS

We might criticise what appeared to be rather loose work of both G2 and G3 in spotting up the situation on their maps; but their requirements are not as exacting as ours in such matters and as long as we are not compelled to work from their maps, but rather from the same information that they work from, the matter is not worth mentioning were it not for the fact that we have so often to wait on information so loosely evaluated or at least recorded.

From the very outset and throughout the entire maneuver, map and physical reconnaissance (on the road only) were kept up, and concentrations were spotted and numbered, being carried on an overlay fastened on the operations map so as to be always available. It was noted again and again that these prearranged concentrations showed up in the "canned messages" as enemy positions or points of assembly. This leads one to the thought that it is a mistake to select the "best" or most obvious positions shown on the map, as the enemy can be presumed to have as good maps and judgment (if not better) than ourselves and would make his arrangements to bring such points under fire just as we do to him. Some of us in our dispositions overseas, recognized this fact and deliberately put our batteries in the "wrong positions", thereby escaping considerable German prearranged fire. Of course, if we should do this in a map maneuver or CPX we would be promptly skinned, so what is good doctrine in war is heresy in peace.

There was some considerable delay, at times, in the getting of Army or Corps orders through to the artillery. Information or warning messages sometimes come through from Army and Corps and reach Division with only one copy available. The Division Commander reads it, hands it to his Chief of Staff, who may or may not summon a conference. Each of the Gs has to have his crack at it, each for his particular use, then the message or order gets to the F. A. Brigade Staff, wherein are concentrated Operations, Intelligence, Supply (ammunition) and Communications. If the two staffs are in the same or adjacent quarters the delays may be lessened by assiduous visiting and prying on the part of the artillerymen. The Brigade Commander may be able to pick out some if not all of the high points during the

THE FIELD ARTILLERY JOURNAL

conference (if held and he is present). Under any circumstances, the artillery dispositions have to be worked out and coordinated, not only within the artillery, but with each and every one of the Gs (G1 usually excepted). His (Arty. Brig. Comdr.) advice and influence must be ready and available to the Division Commander on the instant, if in conference, or at least within a very short time. It is likely to happen that the very bit of advice he is called upon to give is so materially affected by the plans and actions of G4, or G3 in a lesser degree, whose positions are still in the formative state, that the Artillery Commander finds himself unable to be positive or definite at this important moment.

It can easily happen that the Artillery Commander has not before him a last definite minute picture of all the factors entering into his calculations. He should, therefore, require his executive to prepare and keep up to the minute a *brief* syllabus or estimate of the situation as it concerns his own command and possible dispositions in case of a movement. With this information he would be much better prepared to attend a conference or give requested advice. In the same way the Chief of Staff could prepare a hurried estimate of the situation which could be read or handed to each member of the conference. Each G and the Artillery Brigade Commander could then state their case and requirements, thus mutually informing each other. There might be some delay connected with this suggestion, but it is believed that the delay would be in initial time only and the subsequent understanding and the general clarification of the situation would result in quicker and better coordinated results.

While the particular G4 with whom the writer had to deal was most zealous and efficient in cooperation, and did everything in his power to assist, this style of cooperation will not always be found in every division. Not that all G4s are inherently contrary, but because human nature is what it is. But even with the most perfect G4s, the Artillery Brigade Commander who does not make a very careful study of the logistics involved in his ammunition supply, and who does not require his whole staff to join in the study, is laying up trouble for himself and his division. This study should commence with the problems of the Battalion Combat

NOTES ON THE AIR-GROUND MANEUVERS

Train Commander, and carry on back through the brigade clear to the refilling point.

In the matter of ammunition supply, there was at first some fogginess; Corps and Division had different ideas in the matter. The Corps Artillery was only attached for a definite period, and the order attaching the regiment of 155 Hows. said nothing about the ammunition train. It was therefore assumed (see remarks later on "assumptions") that the Divisional Artillery would attend to the supply. Later it was learned that Corps was assuming that they would do it themselves. On the other hand, in the case of a brigade of portée, less one regiment, it was assumed that it attended to its own supply. As the texts available (F. A. S. Notes Bk. 1, Chapter XII, Part J, Par. 6) would seem to indicate either way, and common sense agrees, would it not be advisable that Corps and Army orders cover this point? Certainly G4 of the Division has a right to know how much extra traffic he has got to provide for.

Here, as with G3, there would be temporary conflicts as to the location of our ammunition dumps; but they ironed out very easily when we caught them and, except for cases where the G4 is not as good as the one we had, they are only mentioned to bring up again the principle of priority for the artillery for locations as well as on the roads. The writer cannot recall any case where G4 did not concede this.

A general principle might be injected here: There is no reason why there should be serious differences or conflicts between men working for the same aim and end, as long as one side is willing to concede that the other has some rights in the case.

For the same reason, the Brigade Ammunition Officer must be prepared to give G4 at any time an estimate of the amount of tonnage (trucks, wagons and caissons) he may be expected to provide road space for. It is not recorded that the particular G4 asked for this information at any time in the maneuver; but under actual conditions he would have been very much after it. It is also not recorded that the Artillery Brigade offered G4 as much of this information as he should have had, but confined its efforts to its own (brigade and attached) requirements. In this, our much to be desired cooperation fell down; but there is no fun

THE FIELD ARTILLERY JOURNAL

in working up masses of figures when other things are happening. G4 is also vitally concerned when the orders emanating from Army or Corps call for an unusual supply of smoke and gas, and all artillery means of transport are loaded with shell and shrapnel. Brigade must be on its toes in such matters, and be prepared to help.

In the initial attack order, there was a provision for a preparation fire of *maximum intensity and density* to commence at 2:00 A. M., all available guns to take part. The jump-off was set at 4:00 A. M. From H minus ten until H plus 1 Hr. 30 min. concentrations of gas and smoke were ordered fired by the mediums and by the army. (Army had a regiment of 155 guns, and a regiment of 240 howitzers in the division sector.) In computing the ammunition expenditure for the brigade and the attached artillery, three guns per battery were assumed as continuously firing at one-half of the maximum rate (2 rds. per minute for 75s, and ½ rd. for the 155s) for four hours. This gave an expenditure of ammunition considerably in excess of "one day of fire". For the brigade there were ordered up to the guns, 8,000 rounds of additional ammunition to be delivered (theoretically at least) prior to the commencement of the shoot. When the ammunition reports got back to Army, there was a rumpus and we were charged with "hoarding ammunition at the guns". While we tried to prove our case, and presumably did, the shock was a severe one to some of the staffs, and gave them a lesson in the cost of carrying out the order. The theoretical state of affairs at the guns and in the ammunition and combat trains gave the Brigade Commander considerable worry. At 6:00 A. M. he had available in the brigade, 3,900 rounds, plus about 2,700 rounds in the wagon section of his ammunition train.

The lesson to be learned was that the usual G4 restrictions on road movements, together with the very necessary tactical restrictions, permitting road movements only after dark, are not calculated to materially assist in providing for any such extraordinary expenditures, nor are the mere physical possibilities of getting the tonnage to the guns in time to be utilized increased by such restrictions. Road circulation was not permitted until about 8:30 P. M. The ammunition train was with the field trains five miles

NOTES ON THE AIR-GROUND MANEUVERS

from the Brigade dump, which in its turn, was two miles from the guns across country, or four and one-half miles by roads. Most of the movement to be made across cultivated ground, soft from recent rains. From 8:30 P. M. until 2:00 A. M. is only five and one-half hours with only two and one-half hours until daylight. The refilling station was fourteen miles from the dumps. The ammunition train, having delivered its load, must return to the refilling point, load up again and return to its station before daylight. If they have to make another trip to the dumps, the chances are that daylight will find them on the road, going or coming. Either we must take chances in the daylight, and relax our restrictions, use larger and faster trucks, or orders must reach the various points where action commences much sooner than now appears considered to be practicable. Under actual conditions, some warning orders would have been sent by Brigade, but coordination with the G4s will influence these.

This brings up the question of the *time element*. *Man-hour: truck or wagon-hour plus tonnage-handling* (loading and unloading)-hour. We spend considerable time spotting our positions, measuring the length of our columns, studying the movement rate tables, etc.; but we do not make sufficient provision for the time consumed in reconnaissances, getting out the initial orders, their delivery at their different destinations, and the time there spent in working out the situations on the maps, the necessary conferences, the physical work of writing out the orders, the cutting of stencils, the running of the machines, the gathering, assembling of the annexes, and the distribution, including the wearisome task of registering in the message centers. The orders covering a movement take no account of interdicted roads, broken down bridges, traffic, etc. They allow no time for the mere reading of an order, and obtaining an understanding of it. (It has been told that the model but voluminous orders governing the St. Mihiel attack in 1918 have not yet been read entirely by some of the officers commanding units therein.) The theoretical six hours for the dissemination of an order in the division may be sufficient, if the six hours starts early enough, but when it starts at the last possible minute, and extra provisions have to be made to get the materials (ammunition, communications and the

THE FIELD ARTILLERY JOURNAL

heavier guns) up and ready for the battle, the situation becomes, at least, complicated. The Artillery Brigade Commander may get a very good idea of the plan of the Division Commander quite early in the game (if he has worked for some time with him, the idea will come earlier), but he finds that G3 and especially G4 are not always as ready, or in the proper frame of mind, to give him some of the details he requires. It seems to be assumed that he (Artillery Brigade Commander) can pluck whole train loads (not French) of ammunition out of the thin air, load the contents into trucks, wagons and caissons, by a wave of the hand and waft (expression studied) the whole, over interdicted roads, never any too good, unload and reload and distribute to his guns, all on a theoretical march table. He must also put in his guns, after theoretical marches according to tabulated time schedules; provide road space and some assistance for the emplacement of the heavy guns that take from six to twelve hours' hard work to do, under the most favorable conditions; and do it all in the hours between dark and dawn, or rather 2:00 A. M. of a late May day, all by virtue of the injection into Army, Corps and Division, orders of that magic phrase—"the artillery to have road priority". And yet the artillery annex, or that part of par. 3 of the division order covering it, cannot be written and still less published until after G3 and G4 have done their stuff. Of course, on a map, with purely theoretical conditions governing all movements and a complaisant and entirely helpful enemy putting his interdictions somewhere else, these things can all be done; but they do not appeal to the practical side of a man's experience.

In the maneuvers under discussion, and assuming there were no previous preparations, there was nothing in Army, or Corps orders, either written or implied, that provided time and means to actually get up the extra amount of ammunition involved in the order for "Maximum Rate and Intensity" for practically four hours of heavy firing, let alone for the rest of the day. Nor was there any provision for the extra amount of smoke and gas called for. The medium and heavy guns and howitzers could not have carried out their orders with the amount of ammunition ordinarily carried by them. Requests by the divisional artillery for additional ammunition were sent in, in the form of warning

NOTES ON THE AIR-GROUND MANEUVERS

messages to the Ammunition Train Commander (assumed) and we had to assume that they were heeded, and the extra ammunition brought up. (Note: Under the rules of the game, all messages were first passed to the Directors, who forwarded them or answered them direct, when they were covered by their instructions.)

Too much reliance seems to have been placed by Corps and Army Munitions Officers on the basic averages called "a day of fire", and no allowance was made by them for compliance by the artillery with Army and Corps orders for "maximum rates and intensity".

In our interest over the tactical and technical we are apt to lose sight of the material means for the carrying out of our plans. We have developed artillery capable of very rapid fire and have trained (presumably) our gun crews to handle the mechanisms at any rate desired; but we are apt to forget that the handling and transportation of the huge masses of ammunition involved is a matter for as close technical study as lateral observation, high-burst ranging, tactical technique, or any of the more or less abstruse subjects we are so fond of discussing and studying. Of what good are rapid-fire guns, trained gun crews, and highly trained and expert officer personnel if we cannot deliver the ammunition required to them? Truly the study of logistics, dry and tiresome as it is, is vitally important; but in studying it the *time-tonnage* factors must not be assumed as always working out according to carefully computed march tables and charts. There is always an enemy factor (X) to be considered.

Would not the training be more real, and therefore valuable, if some of these real, tangible and practical obstacles and delays were introduced into the problems? They are permitted occasionally to inject themselves during the course of the action, but only as affecting local events and situations. Would not a more careful study of the time element disclose the fact that in our desire for action and military promptness, we are often trying to do the impractical and forming judgments and opinions that actual conditions will utterly destroy, and in destroying them will wreck our self-confidence and morale, besides causing enormous unnecessary losses in materiel and men? We state in an order that such

THE FIELD ARTILLERY JOURNAL

and such an organization will clear a certain point at such and such a time and we know that, within all reasonable probability, and under almost perfect conditions, the time is reasonable and the thing can be done. Provided, of course, that enemy fire does not unfortunately come down on us at a critical moment. Would it not then be just as practical for Army, in issuing its order, to include in it a time schedule when the Corps and Division orders *must* be completed and on their way? Full allowance to be made for message time of delivery (including the routine performance in the various message centers). In problems, many elements or situations which would consume considerable periods of time (emplacement of army artillery for instance) might be stated as accomplished by a certain stated time (even prior to the issuance of the order), and also that certain details of supply have been completed or will be completed at a given time. All of this could be shown on a rider or appendix (not annex) accompanying the initial Army order and carried through the Division orders. These "trimmings" would, it is believed, materially assist in dispelling that fog of impracticability and even distrust that envelops one when he tries to work out against the actual time, the very probable time of accomplishment. Training of our staffs and commanders is what is sought in these maneuvers. If that training be faulty in the impression it leaves of the *man-hour* element, to that extent is the training injurious to all concerned. These remarks should not be taken "as fighting the problem". They occur to the writer and his aides after several weeks of thought and consideration. We have tried to reconstruct and interpret the lessons learned and impressions received, and to reduce them all to readable form.

To expand the thought of the latter part of the foregoing paragraph and considering only the problem idea:—Certain conditions and assumptions have to be made in all such exercises. These are known to the team which works up the whole and writes the initial order. This order must conform to the prescribed form and contain the more or less standardized information. In its bald and issued form there is no indication of the assumptions which have necessarily been made. The order finally works its way down to Division, the Gs and that wandering,

NOTES ON THE AIR-GROUND MANEUVERS

prying (and often profane) soul, the Artillery Brigade Commander. One or all find certain blanks in the picture which they cannot fill. The Directors may be appealed to and permit certain assumptions. (NOTE: In the initial stages the relations of the Directors to the commanders and staffs are apt to be a little stiff. The staffs are afraid of asking questions for fear of running into a note of deficiency or worse. The Directors do not wish to appear to be too "nosey" or unnecessarily helpful. Result: an impasse.) Even if these assumptions are reasonable, a haunting fear remains in the mind of the staff that maybe that is not what was intended or else their more or less expert knowledge of the particular point cause them to differ. Would it not be advisable to include in the rider suggested above a set of assumptions which are to be taken as gospel coming from the "Team"?

One small incident occurs to the writer in this connection:—The order (Corps) directed the Divisional Artillery Commander and the commander of two army regiments (one of 155 guns and one of 240 Hows.) to coordinate in the location of these units. After waiting some time and writing a message or two which might or might not have gotten through the "Message Center", we placed the regiments to suit ourselves. A day later, being in touch with Corps, we asked how it was that these units could have been emplaced in the time allowed from receipt of Army orders to the commencement of the action. The answer was: "I asked Army about that and he said the pits had been dug a day or so previously." Then, in trepidation: "Where did he say they were dug?" At _____ and _____ (just the places we had put them). Marvelous coincidence, until it was remembered that one of our messages had been accompanied by an overlay showing where we wanted to put them. Would that Army and Corps were always as happy in their choice. In this particular case it was learned later that the troops commanders of both Army and Corps Artillery were "assumed". In other words, the Directors should have given the information. This was hardly fair to the Directors as both were Infantrymen and could hardly be expected to place themselves in the position of

THE FIELD ARTILLERY JOURNAL

Army and Corps artillerymen. The set of assumptions would have cared for this situation.

Liaison and cooperation between Army, Corps and Divisional Artillery Commanders seemed not to have been as well worked out, understood and practiced as it might. In one Corps the Army artillery was directed by Corps order to cooperate as we have seen. In an adjacent Corps the Army and Corps artillery was crowded in and pushed so far forward that less than one-half of the divisional sector was left for the two brigades under the command of the Division Artillery Commander. In fact, he was obliged to superimpose his brigades (he had two) on a perfectly flat terrain and fire diagonally across the front of the Corps and Army guns, to support a little more than half his infantry. In addition, his division commander attached his regiments directly to the infantry brigades. The problems of fire direction, conduct of fire and communications must have been pretty serious, if they gave any thought to them. To the writer it looked like a perfectly impossible situation, even on the map.

Lateral liaison between the artillery brigades was established (through the message centers) and, aside from delays ranging as high as twenty-four hours, overlays and requests for special fires worked out very nicely. Some of these requests were actually based on "canned messages" giving information of enemy batteries located in front of one division firing into another. This was a distinct innovation, as out of some ten or a dozen joint CPXs the writer has taken part in, this was the first time the "Team" had allowed such a thing as being at all possible. There was no lateral wire communication owing to the expense involved or the lack of imagination somewhere.

It would be interesting for field artillerymen to take part in one of these joint exercises where he would be permitted to use the Artillery Information Service and the Artillery Brigade Communications, either actually or through the "canning factory" and a separate message center with personnel familiar, with a portion at least, of our technical terms. It is pretty hard to maintain one's interest in a problem where practically all the information we would normally receive through our own channels is first determined by an infantryman, then "canned", passed

NOTES ON THE AIR-GROUND MANEUVERS

through the D. L. & W. (delay, linger and wait or what have you) center, necessarily overloaded and then dependent on the speed and judgment of one or more of the Gs for the interpretation and evaluation of the messages and then given you after it is so cold and stiff that signs of disintegration are apparent.

We tried to keep alive our interest in our totally non-existent communications system by calculating the amount of wire consumed in the brigade after three days of movement fighting. Messages were sent out to salvage all possible wire (totally unnecessary to any live communications detail) in order to protect us against the charge of "hoarding in the batteries". We then estimated that each battery lost about one-third of its wire each time it moved and the battalions in the same ratio. This gave us a consumption of one hundred and five miles. The division signal officer wrote a message showing the expenditure and asking for replacement. Unfortunately it was mislaid and did not get through to Army as we had hoped; so the hub-bub and argument that followed our ammunition reports was not renewed. However, we were told at Army later that at most only about a third would have been allowed. Yet, we thought we were pretty conservative in our estimates.

While the maneuvers were joint between Air and Ground, and the Air Force did wonderful work in spotting panels, their force was too small to permit of their doing much else than play their own game. Each Corps was allotted four observation planes, or in other words, each Division was entitled to two two-hour periods each day, one plane being assumed as a command plane. (See F. A. S. Notes, Book I, Chapter XXXI and C Par. 26.) The radio equipment provided at the Division P. C. could communicate with a plane, but as far as the writer was concerned he made no use of it. In this, his own unsatisfactory war-time experience might have been to blame, or, what is more probable, his imagination was wholly lacking in that he could not visualize a plane determining the effects of concentration, when the physical concentration was entirely lacking. On the first day a request was made for photographs covering the immediate front of the division. A day later some beautiful photos came, but they were

THE FIELD ARTILLERY JOURNAL

of the extreme area that the division reached three days later; they were very useful then.

The idea of staging a theoretical shoot was dismissed as foolish. Nothing could have been gained by asking for reports on the firing of the howitzers, unless the "can factory" had arranged for it, and then the Directors would have functioned just as well. In fact, one Director did spring something of the kind and opened up quite an interesting bit of side discussion, but the whole was outside of the "canned stuff". Had there been "canned messages" sent to us by radio from the planes, or dropped by them, we might have allowed our imagination to take flight and have gotten something (theoretical, of course) out of it. We did send one message asking for the bombing of an enemy battery which Corps howitzers could not reach (Army was too busy to help at the time); but it was only a director "canned" affair and we got the results asked for without the physical help of the planes. Aviation sent no liaison officers and we had none to send, so the net result was the daily delivery of a front line report of positions spotted (wonderfully accurate in every case) through the medium of dropped messages which, after working through the weary course of the Message Center, landed among the Gs. By the time we got them, the lines had moved. The writer is not competent to state what benefit Army and Corps received from the air, as far as the ground troops and their operations were immediately concerned; but, judging from the critique, no one seemed to have thought them worth while mentioning. For the theory of such joint operations the reader is referred to the reference given above (F. A. S. Notes).

In the case of the one balloon allotted to the Division, the Division Commander very kindly turned it over to the Artillery Brigade Commander and he promptly forgot all about it on the first day. Then, when his memory was rudely jogged, he brought it up and placed it in position and sent it up. That balloon had more difficulties and troubles than the traditional one-armed paper hanger. Every time things got a little dull she was sent up and the Director used his by no means faulty imagination to stick the Brigade Commander. Once the truck got hit and G4 was unable to help out, so the ammunition train donated a truck to

NOTES ON THE AIR-GROUND MANEUVERS

tow the balloon truck and both got stuck in the mud. As far as observation for the 75s was concerned, that was out of the question. The distance from the front line, ground wet, soft, black gumbo would not have shown bursts. Ground haze was bad almost all the time. The enemy planes were very active and we had no planes to call on. Theoretically some reports were received that were worth while, but imaginations and knowledge of the maps and conditions influenced these. Certainly we did not envisage all that could be accomplished with this agency, even under adverse conditions. Some actual experience or practice with both guns and balloons would be of value in determining the best use of this agency for the Divisional Artillery Commander. We are not discussing it from the standpoint of the heavies. However, if the balloon is to be made and used as a factor in a CPX, the "Team" must do their part and produce some plausible "canned stuff".

The "Message Center" has been mentioned several times in the foregoing and usually in terms that are not complimentary. There seems to be no question but that the machine or method has a place somewhere along the line. That place is not in connection with operations. The system is too slow and cumbersome. If introduced into business of any kind it would last just long enough to throw it out. The writer has seen some variations of the system in certain large plants, but there the system consisted in furnishing an escort to business visitors or the transfer of papers from one department to another by boys, or, as in one case, by a quite good-looking girl. The PAX and the Information girl or boy give some approach to it; but they are chain lightning compared with the army system.

The system is archaic and does not seem to be basically suited to any phase of life short of a South Sea island inhabited by six Englishmen with no one to introduce them, but faced with the necessity of communicating. The writer knows that the fury of Hell and of a woman scorned, both combined, have nothing to equal the attitude of the "*Message Center Specialist*" when his D. L. & W. institution is criticised. To expect even a high-school graduate of the average grade of intelligence to decipher a message using terms with which he is entirely unfamiliar, transmit

THE FIELD ARTILLERY JOURNAL

it over a telephone to a man of equal intelligence and expect that speed and accuracy will be obtained, is the nth degree of optimism or something else. Any one who has used the telephone in connection with the telegraph in business knows that mistakes and bulls will occur and we take care of that by always mailing a confirmation. Even with the present-day mechanical means of transmission where the human element is reduced to the minimum we occasionally have errors in technical words, especially when the telephone is used. Those who have had occasion to use a stenographer know that great care has to be taken with the average one, when using technical words and phrases and that figures are particularly prone to become transposed. Nor does it assist in the rapid manipulation of sundry battalions and ammunition trains to have to wait for your own overlay and accompanying message to be registered and a delivery slip made out which you wish to take to Corps yourself. By actual count, this process took twenty minutes, partly owing to the fact that the personnel was busy trying to transmit a message and the "sacred book" was in use. The writer acknowledges the utter heresy of the foregoing; but he cannot compare the absolutely idiotic slowness and inefficiency of even the very best possible "*Message Center*" with common practice in civil life, where a long-distance phone, the telegraph and the air mail are in daily use—where even the lapse of an hour for a fast message to cover several hundred miles and be delivered is often regarded as slow service. The argument of the "*Message Center Specialists*" that more and better trained personnel will settle the problem is neither sound nor practicable. You have got to rely on the lower scale of the average in the army for work of this kind; the upper scale are too much in demand for other things. More of them will only add to the confusion. The Message Center is several steps behind the Comic Strip office boy.

As will be noted in the foregoing, the brigade practically ignored the regiments in assigning areas and subsequently in the orders directing movements. This was partially caused by the setup of the maneuver preceding, and partially from the conviction of the Brigade Commander that in situations involving the coordinated movement of bodies larger than one division and

NOTES ON THE AIR-GROUND MANEUVERS

the necessity of retaining the command of the artillery by the Division Commander, the function of the regimental commander becomes one of coordination, information, liaison, administration, and supply, while the brigade conducts the tactical phases directly under the orders of the Division Commander.

The question arises as to how much delay can be eliminated by cutting out the regiment and what simplification or the reverse there would be in communications. It is not believed that there would be any decrease in the officer or enlisted personnel, wire carts, etc. Both battalion and brigade would have to add personnel for operations and administration. The thoughts evoked seem to be worth study and discussion, as there are many valid arguments pro and con.

In closing, we cannot avoid recording a thought that comes to us as we compared the five regiments of field artillery which were usually with this division to the four of infantry (for this purpose we revive the regiment, it looks bigger). The auxiliary arm with its masses of matériel and large tonnage of ammunition, together with its power to overwhelm and destroy but not to occupy, will more and more dictate the terrain to be fought over, to the end that positions from which to fire and observe will increase in importance at the expense of those over which the infantry may more easily maneuver. To those who have read General Herr and other foreign writers this idea will not come as a revelation, but it will be a long time before it will become very generally adopted in these United States.

To the other B.Gs. who may read this and whose good fortune it is to command an artillery brigade: Don't try to play all the instruments in the band. Let your Staff do it, while you sit by and watch, and watch, and watch and above all *think*. Then, after you have thought long and hard, make a suggestion and don't be sore if they turn you down. Whatever you do, don't take the work out of a staff member's hands and try to do it yourself. If he is not competent, fire him and get another. If he is competent, leave him alone and guide him, if necessary.

ALL-PURPOSE ARTILLERY TRACTION

BY MAJOR L. R. COLE, 6TH F.A.

MOTORIZATION, GENERAL

The experiences of the motorized artillery with the Experimental Mechanized Force at Fort George G. Meade during the summer of 1928, at the division exercises at Camp Dix this year (1929), and the recent commercial developments in motor vehicles, lead the writer to believe that there is now considerable new data on motorization of interest to artillerymen.

This discussion is not the motor versus the horse, but it deals with a method of motorization for light artillery to make it suitable for efficient operation as division artillery (whether the division be on foot or entrucked), to accompany a mechanized force, or for G.H.Q. Reserve for strategic movement rapidly over great distances. It is only recent commercial developments that make practical this dream of all-purpose traction for artillery.

No claim of great originality is made for the ideas set forth in this article. They are rather a compilation of conclusions reached in discussions with other artillerymen and confirmed by personal observations of artillery under varying conditions.

THE FIRST BATTALION, SIXTH FIELD ARTILLERY

This battalion functioned during the summer of 1928 as part of the Experimental Mechanized Force at Fort George G. Meade, Md., and is equipped to function both portée and tractor drawn. When portée, the tractors, guns, and caissons are loaded in class B (Liberty) trucks (one battery loads its tractors on trailers and tows them behind F. W. D. pneumatic tire trucks). Bucket seat cross country cars are used for reconnaissance and light trucks for other detail personnel.

The personnel had intensive preliminary training in operation and maintenance of motor vehicles at both Camp Holabird and Aberdeen Proving Grounds, so may be considered as exceptionally well trained. The battalion as a whole has had extensive training in marching portée and in maneuvering tractor drawn.

ALL-PURPOSE ARTILLERY TRACTION

THE CAMP DIX PROBLEM

The 1st Division Exercises held at Camp Dix in June this year (1929) were for headquarters personnel and communication units only.

The units from Fort Hoyle that took part in the exercises were: The Headquarters and Headquarters Battery, 1st Field Artillery Brigade; Headquarters and Headquarters Battery, 6th Field Artillery, and Headquarters and Headquarters Battery, 1st Battalion, 6th Field Artillery. These units functioned motorized throughout the exercises, the 1st Battalion, 6th Field Artillery, furnishing a large portion of the necessary motor vehicles. This battalion was handled throughout the exercises as it is actually equipped (both portée and tractor drawn), hence its place in column was assigned to give it room for movement by bounds. This in all cases was at the tail of the column of combatant troops.

The exercises were held in an area that had roads varying from main hard surfaced highways to poor sandy country roads and the vehicles of the battalion operated over all of these types.

The details of the Camp Dix exercises have no place in this article, as it is only in the lessons learned that we are interested. The conclusions drawn by the writer with respect to the present battalion equipment are:

a. The road space (2400 yards) is excessive.

b. The battalion operating portée cannot march in column with foot troops as the motors will heat at slow rates of travel. Operating tractor drawn, in column with foot troops, is also unsatisfactory for, while the tractor can operate at the slow speeds, the wheeled vehicles (light passenger and reconnaissance vehicles as well as the trucks that portée the guns and tractors must be marched separately. This introduces the following disadvantages:

- (1) Reconnaissance vehicles will not be available when needed.
- (2) The wheeled vehicles will require much road space to permit movement by bounds. This space will normally not be available, as other troops (supply, combat troops of other divisions, etc.) will be following close in rear of our combat columns.

THE FIELD ARTILLERY JOURNAL

c. Wheeled vehicles in the artillery column are a constant source of trouble for the following reasons:

- (1) They are limited to roads or fairly good cross-country terrain.
- (2) On sandy or muddy roads they become stuck and as this type of road is usually narrow, they block traffic.

d. The gun sections (tractor drawn) can function satisfactorily over difficult terrain and the reconnaissance vehicles can do so over normal terrain, but as soon as detrucking starts there is a great parking problem for the trucks that then become surplus. This may or may not be easy of solution, depending on local conditions.

e. The battalion can function well on good roads where plenty of road space is available. Under favorable conditions, an average speed of twelve miles per hour can be maintained. Hills and poor roads will materially cut down this average.

f. Substitution of new type four wheel drive pneumatic tired trucks for the older types the battalion now has will greatly lessen some of the disadvantages listed. It is quite astonishing what some of these new type trucks will do, both with respect to negotiating difficult roads and terrain and as to speed over good roads. However, these considerations would only lessen the disadvantages, not eliminate them. Pneumatic tires also introduce an additional source of trouble on the battlefield. At best, a wheeled vehicle is a poor cross country vehicle. Ditches, logs, sand, mud, etc., can be negotiated only slowly, if at all.

g. Suppose we eliminate the portéé feature and operate tractor drawn:

- (1) The wheeled vehicles still must be assigned a place in column where they can move by bounds; thus they require great road space and will probably not be available when and where needed.
- (2) The battalion will then not be able to operate with entrucked infantry or make long and rapid strategic moves.
- (3) Reconnaissance over poor roads and difficult terrain will still be unsatisfactory.

ALL-PURPOSE ARTILLERY TRACTION

A STUDY OF POSSIBLE SOLUTIONS

a. *Mechanized Artillery.*—This is understood to mean artillery on a self-propelled mount that also shoots from its mount. This type of artillery is discussed because it has many warm advocates. The following are a few of its disadvantages that make it seem advisable to drop it from serious consideration:

- (1) It is necessarily a large heavy mount that is difficult to conceal when in position.
- (2) It is difficult to design it so it will have a large field of fire without traversing the mount itself; one of the primary requirements of light and medium artillery is that it be able to traverse quickly over wide fields of fire. To traverse the mount involves a considerable time when the necessity of starting the motor is considered.
- (3) It ties up both the gun and prime mover in one carriage, which is a serious matter when repairs to the motive portions are considered. Any one familiar with motor vehicles realizes that they require much in the way of inspections, adjustments, overhaul and repair if they are to be kept at peak efficiency. With the gun and motive power combined in one carriage, the adjustments, repairs, etc. to the carriage and motor cannot be carried out without putting the gun out of action. Also difficulty is experienced in designing such a vehicle to make motor, transmission, etc., accessible for maintenance and repair.
- (4) The design of such a vehicle is necessarily complicated and its manufacture expensive to the extent that the cost in adequate numbers would probably be prohibitive.
- (5) Most serious of all is the fact that it is an exclusively military design and does not fit in with any commercial need, hence only a limited number of manufacturers will be prepared to produce it in emergencies.

b. *Artillery drawn by convertible wheel to track-laying type vehicles.*

Designs of track-laying type vehicles that can operate at speeds up to twenty-five miles per hour have recently been built

THE FIELD ARTILLERY JOURNAL

and successfully demonstrated at Camp Holabird and Fort Meade. These vehicles have sufficient speed for all artillery purposes. However, it is believed that the wheeled type for good roads has such marked advantages that the convertible type (wheel to track-laying and vice versa) vehicle should be the ultimate goal. Let us tabulate and discuss the advantages and disadvantages of this type of artillery:

- (1) The vehicle can be a combination tractor and cargo carrier. This means that the 75 mm gun section, for example, would consist of a convertible wheel track-laying chassis of approximately three-ton weight, carrying a cargo body that would hold two hundred rounds of ammunition—about a two-ton load, and a gun trailed behind the tractor.
- (2) The saving in road space over any present arrangement is important.
- (3) The gun section can travel rapidly over good roads and can negotiate very difficult terrain by converting to track laying when necessary.
- (4) With the gun in position, the tractor can remain and function as a caisson, go for more ammunition, go for repairs, etc., or be readily concealed if not needed for a time.
- (5) The same type vehicle can function in the battalion combat train, the brigade ammunition train, or anywhere that a cargo vehicle is required.
- (6) The same type chassis made in suitable weights and with proper designs of body will function as reel carts, reconnaissance and personnel vehicles, machine shops, tractors for medium and heavy artillery and, in fact, for all artillery purposes. This will greatly simplify design, manufacture, and spare parts supply of artillery vehicles. A list of vehicles necessary for a light artillery battalion is tabulated below.
- (7) The need for any ordinary wheeled type vehicle is thus eliminated and passenger and reconnaissance vehicles, as well as firing batteries and combat trains, can go cross

ALL-PURPOSE ARTILLERY TRACTION

country as necessary, whether to reach positions or detour road jams.

- (8) In addition to higher speeds, the vehicles for all artillery purposes can be designed with one speed to conform to the rate of march of foot troops, for picture as we may the need for high speeds on the road as part of a truck or bus column, the fact remains that many times on or near the battlefield, artillery must conform to the rate of march of foot troops.
- (9) Design and manufacture of the vehicles discussed present no great technical difficulties.
- (10) Our present type of guns will not stand up when trailed at the high speeds contemplated. In a new design, rubber-tired wheels, ball or roller bearing axles, and sprung weight would be necessary. We have a large number of guns now on hand which we would have to use in the early phases, at least, of the next war. It is understood that plans are now being worked out for auxiliary attachments to permit present light and medium artillery being trailed at high speeds. Developments along this line will be of interest to the artillery.

LIST OF PROPOSED VEHICLES FOR 75MM BATTALION

a. The following types of vehicles would be needed:

- (1) 3-ton tractor with the followings essentials: (For firing battery, combat train, and general cargo purposes)—
 - (a) 20-25 miles per hour on roads.
 - (b) Track that will stand up on roads or convertible to wheel type for roads.
 - (c) Slow speed to permit operation in infantry column—3 miles per hour.
 - (d) Cargo body to hold 200 rounds of 75s.
 - (e) Pintle for trailing gun.
- (2) 3-ton tractor (kitchen).
 - (a) Same as "(1)" except designed to accommodate a range and carry provisions. This should be covered and designed to permit preparation of meals enroute.

THE FIELD ARTILLERY JOURNAL

The range must be an oil-burning type, preferably gasoline.

(3) 3-ton tractor (water tank).

Same as "(1)" except mounting a 500-gallon tank with pump faucets, etc.

(4) 1½-ton tractor (cargo type for details).—

Same as for 3-ton above, except body to hold instruments, radio equipment, etc.

(5) Personnel.—

Same as preceding, except body to be designed for personnel—covered, preferably with light armor.

(6) Command Post Tractor.—

A 1½-ton tractor as above with special body designed as a command post. The body to be the enclosed type with drop tables on the outsides and folding awnings that can be stretched out to form a tent (details of this body are too extensive to describe here. Several were in use at the Camp Dix Exercises).

(7) 3-ton tractor (gas and oil).—

Same as "(1)" except, to mount one 700-gallon gas tank and two 50-gallon oil tanks.

(8) 3-ton tractor (machine shop).—

Same as "(1)" except body to be equipped as a machine shop. (Three of this type necessary—one with power plant, lathe and drill press; one with tools, vices, etc., and one for spare parts).

(9) 3-ton tractor (reel and wire) (1½-ton may be better).—

Same as "(1)" above, except body to be designed to mount two separately driven demountable spools of wire for both laying and taking up wire, with room ahead of the reel for extra spools of wire.

b. The following tables show the proposed vehicles as compared with the present:

ALL-PURPOSE ARTILLERY TRACTION



MACK DUAL PNEUMATIC TRUCK DESIGNED FOR SPEED WITH HEAVY LOADS



SAME TRUCK EQUIPPED WITH NEW-TYPE TREADS FROM WHICH DRIVING ROLLERS AND TUGS HAVE BEEN ELIMINATED

THE FIELD ARTILLERY JOURNAL

PRESENT VEHICLES OF THE 1ST BATTALION, 6TH F. A. (Assuming Battery "B" active and equipped like Battery "A")

	<i>Truck</i> 3-Ton	<i>Truck</i> 1½-Ton	<i>Trailer</i>	<i>Passenger</i> Cars
Bn. Hqrs. Battery C, Tn. and Serv. Section	15	5	6	7
Battery "A"	16	3	0	4
Battery "B"	16	3	0	4
Battery "C" (using trailers)	<u>8</u>	<u>3</u>	<u>6</u>	<u>4</u>
	55	14	12	19

Allowing 27 yards per motor vehicle and 5 yards per trailer, the battalion requires slightly over 2400 yards road space.

PROPOSED VEHICLES—HEADQUARTERS BATTERY

	<i>3-Ton</i> <i>Tractor-</i> <i>Trucks</i>	<i>Light</i> <i>Tractor-</i> <i>Trucks</i>	
Reel and spare wire	2	..	
Radio detail	1	
Telephone detail	1	
Command and Recon.	5	
Courier service	2	(A light vehicle,—¾-ton—would be better, but it is desired to stay to two weights)
 Kitchen and water	 2	 ..	
Baggage, etc	2	..	
Maintenance	3	1	
Bn. Headquarters	1	
	<hr style="width: 100%;"/>	<hr style="width: 100%;"/>	
	9	11	

COMBAT TRAIN

	<i>3-Ton</i> <i>Tractor-</i> <i>Trucks</i>	<i>Light</i> <i>Tractor-</i> <i>Trucks</i>
Officers' use	2
Ammunition	9	..

BATTALION SECTION OF SERVICE BATTERY

Gas and oil	2	..
Supply	2	1
Command	1

FOR EACH OF THREE GUN BATTERIES

	<i>3-Ton</i> <i>Tractor-</i> <i>Trucks</i>	<i>1½-Ton</i> <i>Tractor-</i> <i>Trucks</i>
Gun sections	4	..
Reel and wire	1	..
Kitchen and water	2	..
Baggage	1	..
Spare	1	..
Maintenance	1	..
Gas and oil	1	..
Signal section	1
Command and Reconnaissance	<u>5</u>
Total	<hr style="width: 100%;"/>	<hr style="width: 100%;"/>
	11	6

ALL-PURPOSE ARTILLERY TRACTION

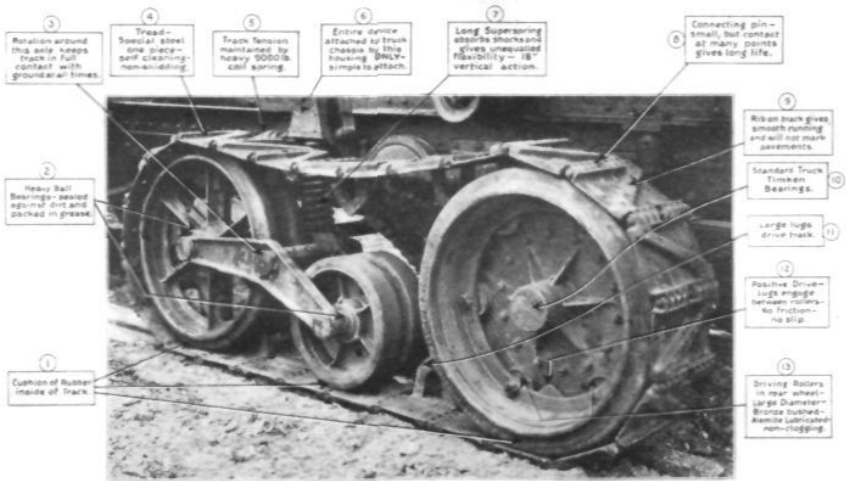

CLOSE-UP OF THE CHRISTIE HIGH SPEED CRAWLER ATTACHMENT



MACK TRUCK WITH HIGH SPEED CRAWLER ATTACHMENT CARRYING A 27,000-POUND TRANSFORMER WHICH WAS HAULED 40 MILES THROUGH THE ARIZONA DESERT

THE FIELD ARTILLERY JOURNAL

SUMMARY

	<i>3-Ton Tractor- Trucks</i>	<i>1½-Ton Tractor- Trucks</i>
Three gun batteries	33	18
Bn. Hq. Battery, C. Tn. and Service Section	22	14
	—	—
Total.....	55	32

Road space at 20 yards per convertible wheeled or track-laying vehicle, 1,740 yards. It should be noted that this provides for an extra reel in the battalion, is liberal in reconnaissance vehicles and includes the service section.

PRACTICAL VERSUS THEORETICAL

The writer believes he has outlined above a method of motorizing artillery to permit it satisfactorily to meet any situation and that it is all within the scope of present-day design and manufacture. There are several other questions, however, that



ARMY EXPERIMENTAL TRUCK WITH PNEUMATIC TIRES IN FRONT AND RUBBER TREAD IN REAR

must be considered. First is the availability of equipment: From the above table an idea can be had of the requirements for one 75 mm battalion. In the six field armies there will be two hundred and sixteen such battalions with additional equipment for the regimental and brigade headquarters units. This represents

ALL-PURPOSE ARTILLERY TRACTION

only about forty-five per cent of the total artillery with these armies and the other fifty-five per cent will have priority on motorization and will overtax the manufacturing facilities of the country for the first part of any war. Also it is understood there are enough horses available to equip the division artillery for several years of a major campaign. It therefore, appears that however desirable it may be to motorize our division artillery, the economies involved will force this artillery into the next war horsedrawn.

The question may now be asked: Why all the discussion about motorization? The answer involves several considerations. As a



WHITE TRUCK WITH RUBBER TREADS

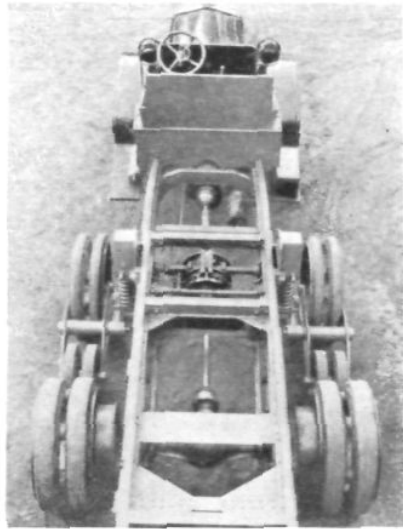

WHITE CHASSIS WITH CRAWLER ATTACHMENT, TREADS REMOVED

war is prolonged, the available supply of horses will be expended while the manufacturing facilities will expand and be able to supply an ever-increasing number of motor vehicles and motorization will gradually be extended to division artillery. Therefore, it is desirable that the plans for motorization of medium, heavy and light G. H. Q., artillery include plans for motorization of division artillery to the end that the same general type of vehicle will be used throughout—varying only in size and weight. This will simplify design, manufacture and maintenance.

THE FIELD ARTILLERY JOURNAL

Another factor frequently lost sight of—as evidenced by many military motor vehicle designs—is the necessity for military vehicles conforming to standard commercial design so that commercial plants can quickly turn, in emergencies, to manufacture of military vehicles. The type chassis discussed above for artillery lends itself readily to commercial purposes as any type body can be used on it to



LEFT—MACK TRUCK WITH CHRISTIE CRAWLER CLIMBING OUT OF EXCAVATION WITH SPECIAL LEVER CONTROL FOR STEERING WHEN FRONT WHEELS LEAVE GROUND. RIGHT—AN 8-TON LOAD GOING THROUGH A SWAMP IN WINTER

meet the particular demand. For instance, the farmer can use it as a wheeled or track laying type vehicle for working his land and as a wheeled type for transporting cargo over roads.*

Manufacture and delivery to the artillery service is only the final stage of a long and difficult process. First, the artillery must decide on the most desirable type motor vehicle. Then a

*The nearest approach in the commercial field to the vehicle in mind is the commercial truck with "Christie Crawler" attached, as illustrated herewith. The advantages of this arrangement are:

- a. Any commercial truck of sufficient power could be converted into a suitable artillery tractor at relatively low expense.
- b. The trucks would be available, or could be readily manufactured, in sufficient quantity, to meet the artillery needs.
- c. The heavier type trucks, with the attachment, would be suitable for hauling medium and heavy artillery, and at the same time carrying a heavy load of ammunition.
- d. The convertible feature (wheel or track laying) would be realized.

The disadvantages are:

- a. The vehicle would still have the regular front wheels, which would tend to mire in mud and would not cross ditches readily.
- b. A converted commercial truck would probably be larger and heavier than one designed primarily for artillery purposes.
- c. The designs illustrated are too heavy for attachment to light vehicles for reconnaissance and personnel carrying purposes. However, there should be no difficulty in manufacturing a light design suitable for any purpose.

ALL-PURPOSE ARTILLERY TRACTION

comprehensive survey and study must be made of commercial conditions to determine the best type vehicle for artillery purposes that will have an extensive commercial demand.

The writer is firmly convinced that a basic principle for this study should be that no strictly wheeled type vehicle is suitable for artillery purposes. For the convenience and comfort of certain personnel, we probably must always have some sedans, but within the battalion there should be nothing but track laying—or easily convertible to track laying—types of vehicles, to the end that the battalion may continue to operate efficiently any time on any normal terrain and under any conditions of weather.



WHAT A SMALL UNIT CAN DO

HEADQUARTERS Battery, 128th Field Artillery, 75 mm Guns, Portée, Missouri National Guard, Columbia, Mo., a unit of two officers and fifty-six enlisted men, in three years has developed a pistol team which took fifth place in the National Matches at Camp Perry, Ohio, 1929, with a team score of 1213, competing against some forty pistol teams—the best in America. Organized and instructed in 1927, the team competed in the 1928 Matches, standing ninth. During the target season between the 1928-1929 Matches, the team fired 129 telegraphic and man to man matches, winning 127 and losing two man to man matches with the St. Louis, Mo., Police.

In the National Individual Matches, 1929, Noland stood 15th among some 600 entries; Courtney, Baker, and Elzea standing in the high 60. Each of these four is entitled to the "Distinguished Pistol Shot Badge of the U. S. Army," the highest medal which any Army, Navy, or civilian pistol shot can win in the United States, due to having qualified the required three times in the high 60 as individuals or as members of a team qualifying in the high third, in the National Matches. This National Guard team defeated all other National Guard teams, and all Reserve and civilian teams, and was defeated only by the U. S. Marine, Infantry, Navy and Cavalry teams. Not being armed with the rifle, thus being ineligible to compete for the Missouri National Guard Rifle Team, this team is sent to the National Matches each year without expense to the Federal Government. The expense is borne by the Regiment and by the State.

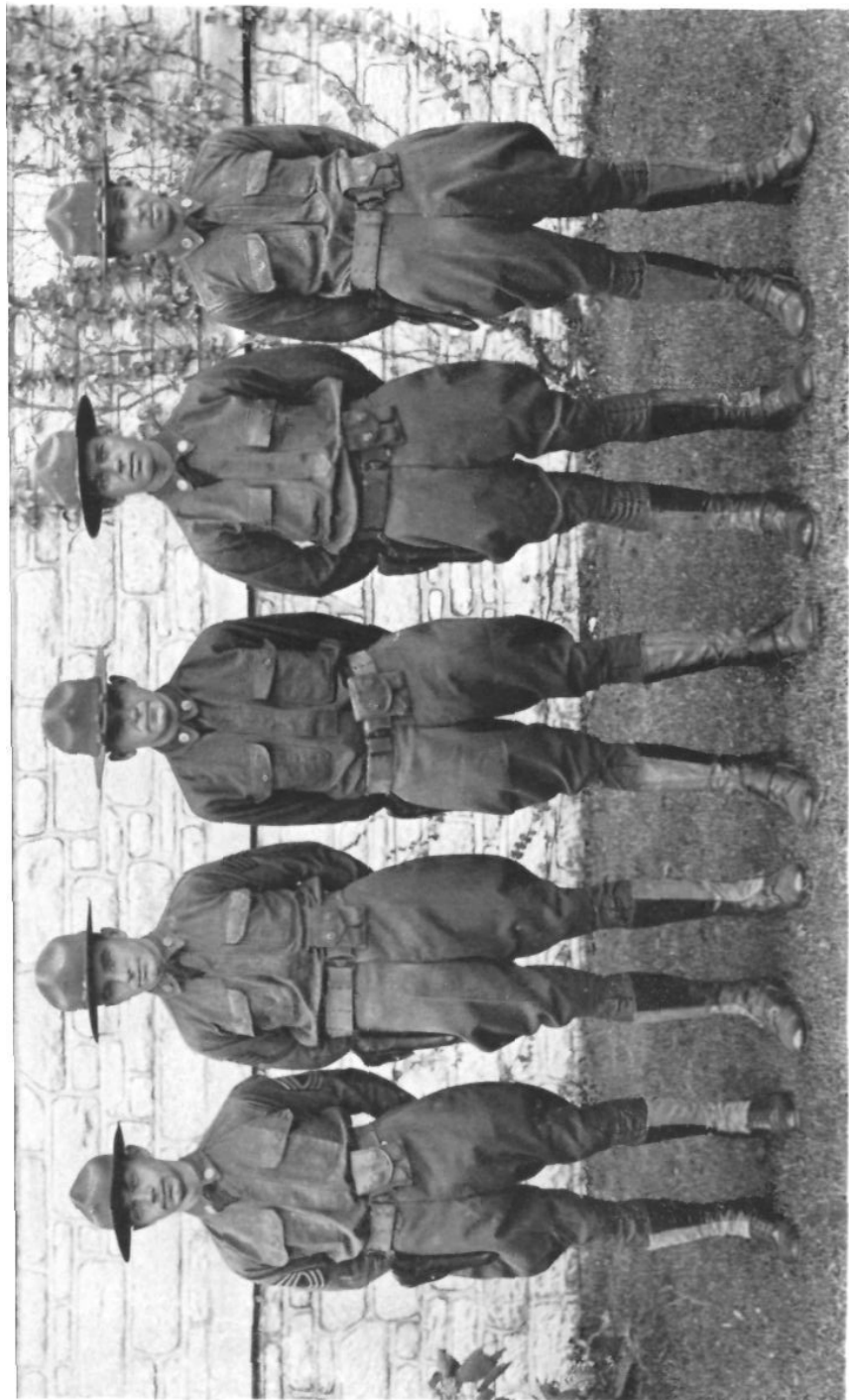

PISTOL TEAM OF HEADQUARTERS BATTERY, 128TH FIELD ARTILLERY

LEFT TO RIGHT—MASTER SERGEANT JAMES G. BAKER, TEAM CAPTAIN; PRIVATE JOHN W. ELZE; PRIVATE OTTO H. MYER; PRIVATE CARL R. COURTNEY;
PRIVATE GEORGE L. NOLAND

WAR BUGS



BEING A WORM'S-EYE VIEW OF THE WAR TO END WAR

BY CHARLES MacARTHUR

*Formerly Private, Second Class, Battery F, 149th Field Artillery, 42d (Rainbow)
Division, A. E. F.*

Pictures by *Raymond Sisley*, formerly of Battery C, 149th F. A.

By Courtesy of Liberty Magazine

THIS is the sixth installment of a Rainbow Division artilleryman's intimate history of his battery's experiences. The previous installments portrayed the trip overseas, the training camp days—and nights, the first actual firing, and then—Chateau-Thierry. In this installment it does some traveling, has some fun, and prepares for a big push.

ON THE WAY TO ST. MIHIEL

Only two privates out of the entire battery got passes to Paris, which confirmed our incipient hunch that they had been serving the captain in some low manner. There was *something* crooked about it, whatever it was.

Fortunately, the captain went to Paris himself, leaving 200

WAR BUGS

and some odd hoodlums in charge of a nervous sorority of lieutenants.

There was no immediate disturbances. After six solid months in the line, with no rest or relief, our present premises looked pretty good. The winding Marne gently elbowed our pup tents and the green grass grew all around. Diving boards went up and a baseball diamond was marked out. Presently the grind of the Ourcq and the Champagne dwindled into pleasant dreams.

In the evening we hitched motortrucks to Le Ferté, six kilometers away, and hooked up with our doughboys. The great deeds of the past six weeks were calmly appraised in corner cafés, and we were forced to the conclusion that no division in France or Germany, or the world, had been so glutted with glory as the Rainbow. Bananas were on sale in La Ferté. We hadn't seen any in nearly a year; and presently the sidewalks were littered with peels for generals and old gentlemen to slip on.

From Le Ferté to Meaux was ten kilometers, and from Meaux to Paris twenty. It looked easy, but the entire distance was lousy with marine M. P.'s. They patrolled the railroads, hid in the bushes, lined the streets, and came out of the floor in every café and co-educational center. Always they wanted to know who we were, where we were going, what were we doing, and were we looking for trouble? It was pretty hot and we had shed a few clothes, so they yapped:

"Where the hell's your blouse?"

The answer to this one was easy and immediate:

"I left it up at the front where they *ain't* no marines."

The M. P.'s usual reaction to this remark was to shove a .45 automatic in the wisecracker's face with the right hand and slug him with the left. Mr. Colt certainly brought a lot of injustice into the world with his inventions.

Often, of course, these S. O. S. cowboys would bump into the wrong guys. One of them poked his gat into the pansy face of Mr. Mike Donaldson, proprietor of one cauliflower ear and twenty-two decorations for heroism, including the Medal of Honor. Mike was very calm.

"What kind of a barrage do you think you can throw with

THE FIELD ARTILLERY JOURNAL

that?" he asked mildly. The marine made some rude reply. Mike grabbed the .45 and rapped him over the skull till it rang like a Chinese gong. Then we hung him over a comfort station and



proceeded to Paris. Incidentally. Mike was Stanley Ketchel's sparring partner some years before he joined up with the army. He was quite a trial to the marines at different times.

Five warworn sightseers thought to beat the rest to Paris by flipping freight trains. An empty box car rattled by and they climbed on. For awhile everything was jake. The most promising milestones whizzed by—Paris, 22K.; Paris, 17K.; Paris, 13K.—and then there was a slight mixup. The train shot through a tunnel. The next signpost read Paris, 19K.; the next, Paris, 25K.—until it became apparent that the engineer was heading for the Somme, where a hot scrap was going on. That engineer was war crazy, or else a marine M. P.

To make matters worse, the train was tearing along at sixty miles an hour, and the first stop was fifty miles from the battery. It took the hooky players two days to get back, having had no fun at all, only hard hiking and a lot of back talk from marines.

Anticipating Cook's tours, the officers had warned us that we were on the Marne for only one day; so most of the battery returned

WAR BUGS

in two, with popeyed accounts of the Eiffel Tower, hand-to-hand encounters with more marines, wild women and experiences with same, together with many narrow escapes from the commander of the American Military Prison at Paris.

Captain Stone had likewise returned, bulging from swell dinners. He declared he would have the law on us all, and might have carried out his threat had not a catastrophe occurred early the following morning.

Vern Sheetz, one of the most popular men in the battery, got up before reveille and dived into the Marne. He became entangled in a mass of sedge and sank before the rest of the battery could reach him. Endless attempts at resuscitation failed and it was discovered that he had died of heart failure.

The needless death of a swell guy is more damaging to army morel than a successful German drive. We buried him in a little parish cemetery overlooking the Marne and moped for a week. Walter Birkland remarked that God was a bum picker. He is, at times. Walter was the next to go.

Rush Dyer, whom we left in a pile of dead at Chateau-Thierry, suffering from the worst hangover in the history of the war (the universal hangover that descended on the entire battery), returned to us the next day, bright and pink and rested. His malady had been diagnosed as gas poisoning, and the French talked of giving him a medal.

They didn't go that far, but they did put him in a hospital next door to a factory full of women, which gave our Romeo something to talk about for a month. In his usual reminiscences Dyer had always operated among debutantes or their betters. He now explained that many of the factory hands were countesses who had descended to toil from patriotic motives.

Asked why he had ever left such an Eden. Dyer looked glum and confessed that his Southern prejudices had been wounded again. Apparently the French had bunked him next to a large and very black Moroccan, whom they unreasonably and assiduously protected from the assaults of the Mississippi Lily. Moreover, the countesses displayed such disgusting interest in his neighbor that there was nothing to do but convalesce and get out.

THE FIELD ARTILLERY JOURNAL

Even this was made difficult by the Moroccan, who began to smell up the whole place. Daily the nurses and doctors fumigated him with formaldehyde. He only smelled worse. Finally his mattress was overturned and the source of all the trouble was made known. It had concealed his belt, with eight human ears sewed to it. He made a terrible scene when deprived of this souvenir, according to Dyer.

Moroccans were fussy about their ear collections, as they considered the good qualities of their former proprietors reverted to the collector. Right enemy ears were preferred—although they let their consciences be their guides and frequently swore that the owners of the left ears were southpaws. We saw them pinching a few at the Ourcq.

On the afternoon of the fourth day in camp we were ordered to move. As usual, the hike lasted all night long. As usual, we scuffed forty kilometers through the choking dust in a direction exactly opposite to our destination. This was done to give us strong legs.



The Moroccan made a terrible scene when deprived of his souvenir

WAR BUGS

At Trilport we loaded into box cars and rattled along the Marne. The railroad had been wrested from the Germans a few days before and the route was a panorama of panic and sudden death. Pontoons, ripped with shell, stood on end in the river. A lot of gents had gone to glory there.

Gaping towns, ground into dust. Optimistic refugees poking about, looking for papa's slippers. Finally St. Dizier and a rum and coffee station. Thence to Domblain, which must mean water tank in French. That's all there is there. We debarked and stepped out for thirty-five mean kilometers, ending up at Huillecourt.

The army and navy forever! Three cheers for the Red, White, and Blue! On arrival, Captain Stone unbelted with the information that we were to rest in Huillecourt six weeks! The fact that we were given a kick in the pants and told to move on nine days later made no difference. We took the announcement seriously and prepared to enjoy ourselves.

Huillecourt consisted of a string of houses on a village street a hundred yards long at the most. There were two cafés—both restricted to the sale of light wine and beer at legal hours. Consequently both sold everything we wanted any time we wanted it.

In the houses were things called beds—the first we had seen in more than a year. We slept like ground hogs. The natives liked us. We liked the natives. Everything was elegant.

The women had big feet and looked like sausage balloons, but rigors of the front had materially affected any fixed ideals of our dreams. Most of the boys had a very low boiling point, anyhow. The little Greek waxed his mustache ten minutes after the kitchen had been installed in the front yard of a little seamstress, and we had to watch our rations like hawks.

The slightest shortage of stew was attributed to his amorous designs, although he assured us that he meant the lady no harm. No more harm than a puff adder, that is. The seamstress complained to Frenchy Monast that the Greek appeared at her window the first night, bearing a large tenderloin steak and winking in a manner that could not be misunderstood. When she resisted his advances he lost his temper and fanned her several times with the steak.

THE FIELD ARTILLERY JOURNAL

Monast felt obliged to punch him publicly in the nose—a gesture that was regarded as something chivalrous and fine until M. Monast moved into the lady's house and began diverting the battery's supply of Y. M. C. A. cookies and jam to softer uses.

Inspired by M. Monast's example, love made its gentle influence felt in the battery and the boys went completely sissy—combing their hair, shining their shoes, shaving five times a day, and otherwise seeking to ingratiate themselves with the female element of the population.

Crap games were abandoned. Drinking ceased. Even so inveterate a poker shark as Joe Bagnuola put Lady Luck out of his life for three whole days while he addressed himself to a large sack of fat known as Fleurette, whose mouth would have been a lifelong career for some competent dentist. Fleurette had a musical ear and demanded that her admirer do something about



Love made its gentle influence felt and the boys went completely sissy—combing their hair, shining their shoes

WAR BUGS

it. Joe's voice was splendid in soliciting his favorite odds of two to one or four, but when raised in song it affected adjacent eardrums something like dull safety razor blades.

Fleurette liked it, however; and long past bedtime the loud and tender discords of *The Sunshine of Your Smile* caromed down the village street, bouncing off all the walls:

*"Deeeeer face, that h-o-o-o-olds So
sweeeeet-a sum-ile for meeee—"*

That was out. Every time Fleurette smiled it was like looking down a coal mine. It would have been fatal to go in there with a lighted match.

In the center of town dwelt Marie, Jeanne, and H  l  ne, the *jeunes filles* of the neighborhood, and very sweet they were, too, all organdie and blushes. Papa was a veteran of 1870 and sported a *M  daille Militaire*, the one incorruptible bona fide certificate of heroism in France. He was very pleasant, but cagy, and such boys as sat in his garden of an evening had to chew cloves and bring a letter from their pastor.

The officers tried to compete with us in this quarter, but we were there first and effectively spiked all their amorous attempts by informing the old gentleman that they represented the lowest stratum of American society and were not to be trusted around decent girls like his daughters. He was greatly astonished and said he had always thought officers had to be gentlemen before they were commissioned. That was the French system of things, he pointed out.

We explained that our particular battery had volunteered from the most exclusive club in America—an organization devoted to such artistic and purely social pursuits that when the war came along and we wanted to enlist, nobody knew the first thing about discipline or drill. So we were forced to hire some fellows who did that sort of thing. We inferred darkly that most of the officers had been ex-convicts, anxious to restore their citizenship by military service. At any rate, we didn't talk to them ourselves and suggested that he follow our example.

The officers never understood the coldness with which their attentions were received, especially when the garden was filled

THE FIELD ARTILLERY JOURNAL

with second class privates showing three very pretty girls pictures of the Woolworth Building and lying about all the automobiles and motorboats they had. The girls reciprocated with a stereoscope and unlimited supplies of export *cassis avec vermouth*. Here and there the pressure of a hand was returned (when papa wasn't looking) and several of us were asked to dine.

The officers nearly went crazy trying to pierce papa's mysterious reserve. They sent him baskets of wine, which we drank, and ordered Sylvester to serenade the house with everything from Bedelia to the Marseillaise. From the garden the concert sounded charming.

Such a situation called for consequences. Under the alibi of exercise the battery was given squads east and west all day long, with plenty of detail work to fill in. There was some comfort in knowing that two of the officers were baking in the sun too, and that the rest weren't getting past the girls' front door.

Another Huillecourt diversion was to tease old Papa Pierre, who was ninety-one years old and proud of it. It was his habit to sit in his dooryard and accost all passersby with "*Quel age avez-vous?*" His voice was tinged with an offensive superiority as he demanded this information. Plainly, Papa Pierre thought that anyone under ninety would never amount to anything.

So, in answer to his question, we invariably said, "Ninety-five." A reply that sent the old man into a fit of rage that nearly did for him more than once. He called us liars, illegitimate, *cochons*, and many other things we did not understand. But we stuck to our point; we were older than he was. And Papa finally took to his bed in a state bordering on apoplexy, after charging among us with his stick.

On the ninth day of our six weeks' rest we were ordered to shove off for another front. The greatest secrecy shrouded our destination. A thousand sectors were suggested, from Macedonia to Lower California. The French with whom we lived got out their maps and pointed to St. Mihiel, which seemed a strange side light on the war. The captain didn't know where we were going; General Pershing didn't know; nobody but all French voters between the ages of sixteen and sixty were in on the secret.

WAR BUGS

Bonfires and cheers attended our departure from the village late that night. The ladies put on their best satin dresses and lined the road, calling *bon chance* and *au revoir*. A few of them wept, bless their hearts.

Irv Carson, whose blue-eyed boobery concealed the cunning of a fox, remained behind. He was missed, and torn from another fellow's girl. In simple fashion he told the captain that she had contracted to bake him a pie, which he had intended to give to the captain. He carried a large pie in support of his alibi. Torn by jealousy, our offended buddy pinched the regimental bicycle and burned up the road to visit Italian vengeance on the weak and fickle sister. He returned with four pies.

Three days of stiff night marches brought us to Reubeville, where the rubes come from. Here we were paid, and Joe Percival spent a cool 200 francs testing the town's supply of rum. He was joined in this project by Herb Mooney and Don Coe, who wanted to dissolve a bitterness deriving from the captain having addressed them as booze hounds. By the time of departure the three were engaged in a fist fight over the correct way to conjugate the French verb "to be." There seemed to be three opinions and no alliances.

Captain Stone was sore as a goat. He announced that all three should precede the battery in its march to the next town as a solemn warning to the rest. The punishment was all right in theory, but not in practice, as the three tipplers held up the march all night long by their frequent and rowdy arguments as to which of them should present their concerted opinion of the captain to the captain—on vellum. Each fought for the privilege. All won.

When we arrived at Neufchateau, Captain Stone sentenced the trio to a bit of carriage washing, the same to last until dawn. The horrible examples waited until they thought the captain had gone to bed, whereupon they indulged in immoderate guffaws.

"Pretty soft!" observed Mr. Percival. "All we got to do is to throw a pail of water over the carriages and go to bed. That guy's so dumb he'll never know the difference. I'll bet he doesn't know what army he's in, even."

THE FIELD ARTILLERY JOURNAL

"I'll take that bet!" said Captain Stone, standing directly beside them in the night. "And those chevrons, Percival."

The rum consumers scrubbed carriages for the next two days without sleep or rest.

A list of new corporals and first class privates was read on our second day at Neufchateau. It was here that the captain spoke of making the writer of this absorbing narrative a first class private—and then meanly changed his mind, on the grounds of irresponsibility. Nobody had asked him for promotion. The crack seemed gratuitous, especially as, in the entire Allied armies, there was no one who had such a fanatic sense of duty, a greater love for Old Glory, or a deeper respect for his officers than this same private.

Ike Sawyer, whose heroic conduct at the Ourcq was ignored in the promotions, waited on the captain to learn why he was overlooked. All of us were a little surprised, as Ike had always seemed like such a nice fellow. Now he was acting as if he didn't *want* to be a private any more.

The captain inferred that he was saving Mr. Sawyer's promotion until he had captured a German sausage balloon, copped the Kaiser's underpants, and demolished the Hindenburg Line—all in one day. Whereupon Mr. Sawyer became quite pink and publicly told his commanding officer of many things that could be done with corporal's chevrons, adding that he didn't want them in the first place. This last remark didn't square him with the boys, however. Ambition had reared its ugly head too conspicuously for that.

Before leaving Neufchateau we ran into some of the various welfare organizations we had always heard about and had never seen. A theatrical company appeared and presented *Baby Mine* in a natural amphitheater back of the barracks. Women who spoke English were rare, and we paid serious attention to *Baby* and none to her difficulties. The next day a beautiful and rowdy young lady appeared and sang slightly off color songs. That was more like it. There were ninety-nine encores.

Free suggestion to the War College: In the next war, lay off Art.

WAR BUGS

Another day or two and we were ordered to rise and shine. Lieutenant Colonel Smith led the column, and seemed to think there was a fire or that he was Sheridan with Winchester still twenty miles away. He ran us bowlegged all the way to Brancourt. Fried rabbit and eggs in this burg. Look for a white cross on the third door.

We had hardly landed in town, panting like Pomeranians, when we were ordered on. Loud squawks arose. Our shoes had burned up getting there, and the men had found a real brewery. However, the centuries looked down upon us, and we limped on. Forty-five kilometers was the gaff that night, after nearly twenty during the day. Put them all together, they spell Mother.

Early the next day, in a blinding rain, we crawled up one steep cliff and down another, then back again to the base of the first cliff, where our camp was cunningly discovered by the officers. The climbs up and down were intended to qualify us as ski jumpers in case Pershing wanted anything done in the Alps. Going up and coming down, the roads were smeared with Grade B lard. One of E Battery's guns slid over the precipice, seriously injuring two men.

A marked down village squatted at the foot of the hill, beside a seedy canal. Here we ate, drank, and made merry all day long. The first we had seen in nearly a year. Ten sous, dropped in a slot, made it go to work on three tunes; our favorite selection being *Sur le Pont de Paris*. Lyricists of the A. E. F. had long ago revised this number into *Après la Guerre est Fini*.

During the afternoon we shepherded all the ladies in town and threw a dance that lasted until the column was on the march. The event was slightly marred by the ladies' unfortunate comprehension of *Après la Guerre*, which the boys insisted on singing as they whirled their welterweights about the floor.

Another night's march over soupy, pitted roads. Through Toul on the trot, with the boys snatching at doughnuts held out by Salvation Army lassies like rings on a merry go round. What those poor girls heard whenever a driver missed a sinker

THE FIELD ARTILLERY JOURNAL

and it rolled in the mud! In the early dawn we squashed into a wet woods near Mandres.

Five days we waited here for the impending attack—five days during which we watered and scrubbed and manicured the nags, tried to send German helmets home, and renamed the guns.

The first piece was christened *There's a Reason*. To supplement the idea, Jack Walsh painted a large German soldier on the shield. The German was quite terrified, his hair standing every which way and his arms high in the air. A balloon issuing from his mouth contained the words: "I Give Up."

The second piece was named *Hell's Belle*, and revealed a lady in a red Venetian mask. This was considered the cat's whiskers—quite equal to the moniker *Indiana* had painted on one of its guns—*Old Dutch Cleanser*.

Americanische Bluff were the fighting words applied to the third piece, and *The Reaper* designated the fourth, which carried a spirited portrait of Death making marmalade out of eight Germans with a big scythe.

Another regiment of Chicago origin appeared in the mud of Mandres—the old First Illinois Cavalry. It was commanded by Colonel Milton J. Foreman, an ardent patriot, a pearl among commanders, and a relative newcomer in action.

For some reason, this budding Napoleon resented our proximity to his men. Perhaps it was because we were in the habit of referring to them as the Dog and Pony Show and the North Clark Street Light Horse.

Such appellations were never intended seriously. At their worst, they were merely luxurious epithets that seniors in the business of war apply to freshmen, and they were certainly wiped out by our compatriots' gallant conduct in subsequent battle. But, whatever the reason for this prejudice, Colonel Foreman served notice on his men that they were to have nothing to do with us.

Without counting ten (we were told) he referred to us as riffraff. We forgave him the term on the grounds that he had just reached France and had let the war go to his head. Anyhow, in our eight months of action better names than that had

WAR BUGS

been invented to describe us. The Prussian Guards called us Black Diphtheria.

More and more men squeezed into the woods—doughboys, artillerymen, and engineers in 10,000 lots. There wasn't room for them all, and it began to look as if something hot was on the fire. Tanks clanked by—hundreds of them. There were some fast whippets, a type we had never seen before. Big guns, little guns, medium sized guns, Minenwerfers, machine guns, and bombs. Ammunition was piled in mountains—enough to blow up the world. It certainly looked like trouble for somebody.

A courier dashed up, dismounted, saluted just like they do in the movies, and handed Captain Stone an order. And what an order!

"An attack will be made against the German positions on the morning of September 12. The mission of Battery F will be to accompany the infantry over the top, for fire at pointblank ranges."

Of all the cockeyed, stark, staring, tittering ways to win a war, that won the brown derby. Firing by deflection from under camouflage was dangerous enough. Now they wanted us to wheel our cannon over the trenches, through the barbed wire, and use them for .45s. It was like killing a fly with a sledge hammer, except that we couldn't help wondering what the Germans would be doing all the time we were hauling the guns over the top. In this connection it was recalled that the St. Mihiel positions had been stormed again and again throughout the war, and that each time the Allies had been repulsed with frightful losses, adding up to 1,000 men for every minute they had held the German first line trench.

Captain Stone called for volunteers. The response was unanimous. That's the worst part of a call for volunteers.

Arising magnificently to his opportunities, the captain made a great speech in which he said that it was the first time a battery of artillery had undertaken a stunt of this kind, and that he knew we would put it over on account of our being such Fearless Heroes.

We began to feel the same way ourselves, and spent the

THE FIELD ARTILLERY JOURNAL

evening writing letters home, cracking bum jokes that were received with hysterical hilarity, and singing such old favorites as Blue Belle, Good-bye, Dolly Gray, and Just Before the Battle, Mother—with rude variations, of course.

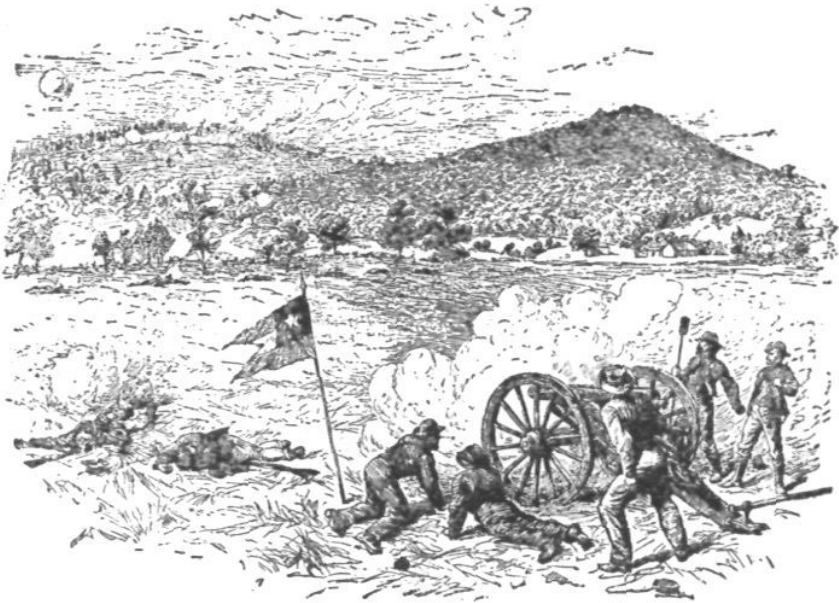

THE LAST CONFEDERATE GUN AT GETTYSBURG—ON LONGSTREET'S RIGHT, OPPOSITE ROUND TOP

MECHANIZATION IN GREAT BRITAIN

BY MAJOR C. C. BENSON, CAV.

THE British expect mechanization to overcome the dominant power of the defensive and to restore decisive maneuver in battle. Their present Director of Mechanization, Major General S. C. Peck, C. B., D. S. O., sums up the situation thus: "We are in a purely experimental stage—feeling our way; but personally I am convinced that mechanization has come to stay. It is the pivot around which future armies must organize." . . . The fighting machines that first appeared in action on the Somme thirteen years ago have risen to high estate. In great Britain at least, their technical improvement has kept pace with the rapid progress of automotive industries; and their tactical employment has become a matter of prime importance. Mechanization experiments, inconclusive as yet, have already worked a miracle—they have shifted the focus of military thought from the past to the future. Old methods are giving away to new; but in the present transitional period, no one can say definitely what effect the motor will have on the battlefield of tomorrow.

WORLD WAR PERIOD

British enthusiasm for fighting machines began with the men who saw the first tanks in action. A soldier's letter, written in September, 1916, and widely circulated in England at the time, gives a vivid impression of the amazement and delight with which those early tanks were received. "They can chew up barbed wire and turn it into munitions. As they run they slash their tails and clear away trees, houses, howitzers, and anything else in the vicinity. They turn over on their backs and catch live shells in their caterpillar feet, and they can easily be adapted as submarines; in fact, most of them crossed the channel in this guise. They loop the loop; travel forwards, sideways and backwards, not only with equal speed but at the same time. They spin around like a top, only far more quickly; dig themselves in, bury themselves, scoop out a tunnel, and come out again ten miles away in half an hour." Slow, unwieldy, and mechanically unreliable though they were,

THE FIELD ARTILLERY JOURNAL

some of these early machines crashed their way through strong German defenses; they terrified the German front line troops, and renewed British hopes for release from the hell of trench warfare. German leaders heaped scorn on their first clumsy efforts; but had they realized the moral effect of these machines, they might have come closer to estimating the true value of the weapon.

The tanks, having successfully passed their initial battle test, were rapidly improved. Sir Albert G. Stern in England and General Estienne in France independently fostered the tank idea, and it was largely through their individual efforts that the "chariots of assault" developed into effective weapons. It required, however, the smashing attack of nearly 500 heavy tanks at Cambrai to convince the Allied leaders that this new weapon could overcome the power of the defensive. From then to the end of the war, the Allies employed tanks in increasing numbers; and had the war continued, 1919 would have witnessed great battles with tanks in the leading role. When the Armistice was signed, work was in progress on 3,500 French light tanks, 5,000 British heavies, 1,500 British-American extra heavies, and 21,890 tanks of various types for the American Army. *A total of over 30,000 tanks would have been ready for action in the Allied armies in the Spring of 1919.* Germany was making strenuous though belated efforts to supply her forces with tanks. Few military men knew the extent of the tank program that was under way when the war ended; and right now there are even fewer who would know how to use 30,000 tanks. Even when employed in limited numbers, tanks had established the fighting machine as a powerful offensive weapon. They helped to restore movement to a situation that had become rigidly stabilized; reduced materially the casualties of attacking infantry; lowered German morale and raised that of the Allies; and pointed the way to one sure line of future development.

PRESENT CONDITIONS IN GREAT BRITAIN

These costly lessons from combat experience have stuck by the British army. It ended the World War with the best

MECHANIZATION IN GREAT BRITAIN

tanks then in existence, and definite ideas on how to use them. Since the war, Great Britain has spent large sums to develop better fighting machines and improved tactical methods. Her responsible civil and military leaders are definitely committed to the policy of extensive mechanization for Regular Army units; she has the necessary scientific and industrial resources to equip, man, and maintain large mechanized forces. There are naturally differences of opinion on when and how to apply this policy, and the usual dearth of peace-time funds for the necessary changes. Measures already taken have undoubtedly placed the British in the forefront of mechanization progress, and there they propose to stay.

Before going into the details of this subject, let us consider some of the factors that affect British mechanization plans. Industrially, the World War was disastrous to Great Britain. Her complicated industrial machinery was thrown badly out of alignment for commercial purposes; the progressive substitution of oil for coal, and extensive boycotts in India and China on British manufactured goods made matters worse. Furthermore, British manufacturers have had to meet stiff competition from European and American producers. For ten years, unemployment has been, as it still is, the most vital domestic problem of the government. Within the past year, conditions have taken a turn for the better; and though there are still over a million workers unemployed, business is picking up. Despite hard times, the British found money for army mechanization experiments, and improved industrial conditions will probably bring more liberal appropriations.

The peculiar situation of the British army hinders any radical change in organization. The Cardwell system binds home organizations to similar units in India; and so long as this system remains in effect, the organization, equipment, and training of the correlated units must be such as to make them interchangeable. In India, the most likely scene of conflict is on the northwestern frontier, in a mountainous region entirely unsuited to machine warfare; consequently, the Indian Army authorities are loath to accept the full measure of mechanization

THE FIELD ARTILLERY JOURNAL

that is desired for home units. These home units may at any time be united into an expeditionary force for service in a theatre of operations where conditions differ materially from those in India. Clashes between Moslems and Jews in Palestine may require Great Britain to send an expedition to preserve order there. Detachments of aircraft, armored cars, and motorized foot troops have already been dispatched to the danger zone. British commitments under the Locarno Pacts indicate Europe as another possible theatre of war. There the terrain is generally suitable for mechanized warfare; moreover, a British expeditionary force could rely upon the co-operation of allied troops organized on traditional lines. Under these circumstances, the expeditionary force might well be completely mechanized. The British improvised a Tank Corps during the World War, and an excellent job they made of it; but no such deliberate measures will do for an expeditionary force. It must be ready to go quickly when the need arises. Hence the protagonists of mechanization urge the immediate organization of strong mechanized units. The British War Office, prodded by enthusiasts at home and repressed by conservatives in India, is in a quandary. Its efforts to reconcile divergent but interdependent interests will take time, and until a satisfactory settlement is reached, British plans for extensive mechanization will be handicapped.

RECENT EXPERIMENTS

In the meantime, experiments in mechanization are under way in England. Fortunately for the progress of these experiments, the British Tank Corps has enjoyed a continuous existence ever since its creation as a new combat branch during the World War. It has preserved the high ideals of service that characterized the Tank Corps pioneers, and have given continuous study to the organization, equipment, training, and tactical employment of mechanized units. Tank Corps units are not normally included in corps or divisions; they are considered a part of the G. H. Q. reserve. The Tank Corps at present includes only four tank battalions and eleven armored car companies; but these units are well equipped and have

MECHANIZATION IN GREAT BRITAIN

had a great variety of practical experience in England, Egypt, India and China, in the mechanical and tactical operation of their vehicles. They are well qualified to set the standard for whatever mechanized forces are organized.

The first of these forces, a mechanized brigade, was formed in 1926 to study the organization and tactics of a unit equipped with armored fighting machines. During 1927 and 1928, this force participated in maneuvers with infantry divisions and cavalry brigades. Having learned what they could from the operations of this force, with the equipment available, the War Office disbanded it. The 1929 program involves a number of experiments with the details of organization and equipment of various small units, but is principally concerned with a combination of motorization and mechanization as applied to two infantry and two cavalry brigades. Tests of various machines, including self-propelled gun mounts, already begun with two field artillery brigades, are to continue. This apparently radical change in the development of mechanization projects indicates expediency rather than policy. The Armored Force was discontinued in order to make its component units and vehicles available for important work in other closely related fields. As in our own service, the real problem of mechanization is to work fighting machines into the tactical thought and practice of the army. When the older branches accept partial mechanization for their own purposes, they will better appreciate the need for separate fast-moving mechanized forces, and will understand how to cooperate with those forces. By enabling the older branches to educate themselves, British mechanization experiments of this year will have a far reaching influence upon the army as a whole.

INTEREST OF VARIOUS BRANCHES

So much has been written about the British mechanized maneuvers, by observers and participants, that it is hardly worth while to recount the details here. However, some items that apply to particular branches are of special interest.

Extensive tests have been made with wheeled and half-track tractors, trailers, armored caterpillar tractors (Dragons), and

THE FIELD ARTILLERY JOURNAL

self-propelled mounts. All mobile anti-aircraft artillery is now motorized, the guns being mounted on trailers which are towed by six-wheeled tractors. Anti-aircraft equipment for the 1929 experiments includes machine guns and anti-aircraft guns mounted on special cross country carriers. The carriers provide armored protection for the engine, the driver, and for the members of the gun crew except when operating their weapons. Two 3.7 inch howitzer batteries, for the close support of cavalry, have been experimentally provided with caterpillar trailers of the Carden-Loyd Mark VI machines. These brigades of field guns have been motorized with Burford and Crossley half-track (Kegresse) tractors, and "dragons." The dragons are apparently in excellent standing at present, presumably because they do the work and fit neatly into the mechanized force. Weight, about nine tons; speed, sixteen miles an hour; capacity, eleven men, 128 rounds of field gun ammunition, and a 3.3 inch gun in tow; engine, air-cooled, the same as used in the medium tank. The latest model dragon has proven satisfactory as a tractor for medium artillery, and has definitely been adopted for that purpose.

Experiments with self-propelled mounts for various artillery weapons have been continuous since the World War. The most recent development is probably the three-inch mortar mounted on a Carden-Loyd Mark VI. Two batteries with these experimental mounts are being tested for use in the close support of infantry. Self-propelled mounts for field guns have had their troubles. The first type produced carried a gun that could be used either as a field piece or an anti-aircraft gun—weight, twelve tons; speed, fifteen miles an hour; capacity, one eighteen-pounder gun, six men, and 1,750 pounds of ammunition; engine, air-cooled, the same as used in the medium tank. A second model gave the crew some protection. The latest model has abandoned the dual purpose idea; it provides simply an armored field gun on a tank chassis, and is in fact nothing more or less than a tank.

Some batteries are now equipped with radio telephones. To provide transportation for battery headquarters and instruments,

MECHANIZATION IN GREAT BRITAIN

a car with a specially designed body is to replace the touring car formerly used.

INFANTRY

The infantry was represented in the Armored Force of 1926-27-28 by one battalion—three machine gun companies of twelve guns each, and one rifle company. Six-wheelers and half-track trucks were used for transportation. The 1929 experiments involve the partial motorization of two infantry brigades—the 6th at Aldershot and the 7th at Tidworth. The infantry battalions of these experimental brigades are not motorized. These tests include the use of Carden-Loyd armored tractors and caterpillar trailers for the transportation of man, ammunition, and weapons. The tractor is comparatively slow, but inconspicuous, light, simple and cheap. It provides partial armored protection for the driver and gunner, and carries either a .303 machine gun with 3,500 rounds of ammunition, or a three-inch mortar which has a range of 2,000 yards. The machine gun can be fired from the machine, but normally, as with the mortar, it is dismounted for firing. When traveling at six miles an hour, the carrier is so rough riding that it would be difficult for a machine gunner to hit a haystack a hundred yards away. The trailer can run on either wheels or caterpillar tracks; accommodates four men or extra ammunition as desired; and when equipped with tracks, has good cross country ability. The .8 anti-tank gun, on its trailer mount, is towed by the tractor; the .5 anti-tank gun can be mounted on the tractor. All of these weapons are intended for the close support of the infantry. Their tactical uses, as well as the best methods of transportation, are being worked out. In addition, the attachment of a light tank battalion to each of the experimental infantry brigades will help to decide whether tanks should be an organic part of the infantry brigade. The idea that fighting machines must actually accompany associated troops has lost ground, but infantry commanders are not yet ready to concede this point. Tactical ideas change slowly, but it seems futile to tie fast, bullet-proof,

THE FIELD ARTILLERY JOURNAL

modern tanks to slow-moving, unprotected infantry. Results of this year's test should throw some light on this question.

CAVALRY

For close reconnaissance, the British consider the horse soldier indispensable and irreplaceable. Nevertheless, two cavalry regiments have had their horses replaced by armored cars. All of the home cavalry regiments have been supplied with light six-wheeled trucks for their first line transport. Each of the two cavalry brigades employed in the 1929 mechanization experiments has Carden-Loyd machine gun carriers in place of the light six-wheelers previously used; some "Baby" Austin scout cars for use on reconnaissance; and a mechanized 3.7 inch howitzer battery. On the march, the howitzer carriage is mounted on a caterpillar trailer which is towed by a Carden-Loyd. This rig appears to be awkward but it is reported to work well enough for experimental purposes. These cavalry brigades are assigned duties, particularly in difficult country, for which completely mechanized units are unsuitable.

The present British armored cars have limited ability to surmount obstacles encountered on the road, or to maneuver across country except on the most favorable terrain. The Rolls Royce car weighs 8,300 pounds; and the new Lanchester, with much heavier armor than heretofore, 13,500 pounds. Several different models of the wheel and track type have been tried without much success, but experimental work along this promising line continues. The service machines carry less armor and fewer weapons than tanks; they are, however, silent, fast, and reliable mechanically. Their great radius of action makes them particularly suitable for long distance reconnaissance. Where the terrain permits, armored cars are used on many of the security and reconnaissance missions that were formerly assigned to cavalry detachments.

ENGINEERS

Remarkable progress has been made in the development and use of bridging equipment, including pontoons, for mechanized forces. The pontoons are light, collapsible, and can be conveniently nested. The roadway of the pontoon bridge is made

MECHANIZATION IN GREAT BRITAIN

with duckboards that can be placed in position quickly. It is proposed to carry the pontoons and some of the heavier materials on specially constructed trailers. The engineer units of the mechanized formations are provided with six-wheeled trucks, and have power driven tools to supplement their normal equipment.

CHEMICAL WARFARE

All mechanized force troops have been equipped with training gas masks. Exhaustive tests have demonstrated that tanks can be operated successfully under all expected field conditions by men wearing gas masks. The Superintendent of the British Chemical Warfare Research Department states, "We satisfied ourselves that it would be impossible to get in the field a sufficient concentration to appreciably affect the engine." To make tanks gas tight, and to provide adequate ventilation at the same time, is considered impracticable at present. The tank developed most recently, Vickers sixteen ton model 1928, has no special provision for protection against gas.

Experiments have been conducted with Carden-Loyd machines as carriers for smoke producing devices; but though the smoke produced was satisfactory, this line of development has received no encouragement from the Tank Corps. An armored vehicle with a weapon that can fire smoke shells, either when in motion or stationary, is considered more useful than the smoke producing machine.

THE CONDUCT OF WAR

BY MARSHAL FERDINAND FOCH

AUTHOR OF "THE PRINCIPLES OF WAR"

TRANSLATED BY CAPT. W. F. KERNAN, FIELD ARTILLERY, U. S. ARMY

(Fifth Installment)

CHAPTER VI—(Continuation)

With regard to the question of his arrangement of forces in depth, we have already seen an example of Moltke's theory of advance guards—a large corps of cavalry supported by a division of infantry several days' march to the rear, and for this reason:

- (1) Of doubtful value as a reconnoitering force;
- (2) Of insufficient strength to offer an appreciable resistance to the enemy.

But worse than all, Moltke failed to keep this body intact or even subject to his orders. He proceeded to divide it up among three of his armies. What was the result? Each army, having its own mission, devoted all its available means to the accomplishment of its own mission. The projected corps of cavalry ceased to exist and the reconnaissance, indispensable to a maneuver involving his whole force, was never made. One lesson we can learn right here: in order that the services of a general advance guard, such as Moltke recognized as necessary, should be assured to the army, this advance guard must be formed as a separate body independent of the army proper and subject to the orders of the Commander-in-Chief alone. Since Moltke did not possess such an advance guard at his disposal, it is easy to see:

- (1) With regard to information—either he would not have any or at best he would receive it too late. Without the necessary information he had either to delay his decisions or make them in accordance with a preconceived hypothesis; that is, he had to act in the dark.

- (2) Lacking the protection necessary to guarantee the concentration of all his forces, he was likely to suffer the misfortune of having his troops stumble by chance upon the enemy without having time to reunite.

In short, any intelligent strategic action was denied him. His armies would move uncertainly from one surprise to another—and

THE CONDUCT OF WAR

what would be the result? The troops themselves would decide the question. Under such generalship if they happened to gain contact with the enemy they would immediately go into action, not because there was any order to that effect from headquarters, but because there was no order preventing it. How could there be such an order inasmuch as headquarters itself had no idea as to the location of the enemy? Finding themselves suddenly in the neighborhood of a hostile force, it would be very necessary that they should decide to engage it in this manner. Their conduct would merely be guided by the proper military spirit.

Thus, even though the Commander-in-Chief reserved his decision the troops would have already concluded the matter. While he, due to the haze of uncertainty in which he moved, was unable or unwilling to exercise active control over his army, the army itself would take control. The conduct of the strategic maneuver would change hands. Operations would be conducted by troops.

Lacking any background of information, without any knowledge of the situation, the troops would be inspired only by the primordial instinct to fight. They attack. The idea of a strategic maneuver spreads its wings and vanishes. But whether or not it would continue to exist as a maneuver in any sense we shall see.

The troops attack:

They do not know what is in front of them—whether they are in contact with the enemy's main body or merely with a detachment. Without any information whatsoever, they are in this respect in the same condition of ignorance as the Commander-in-Chief and the army commanders. They do not know whether or not they are in a favorable situation for an engagement. They do not know the plans of the Commander-in-Chief, which, due to insufficient or delayed information, have either not been formulated at all, or no longer conform to existing circumstances. They do not understand the general situation of their own army, and therefore they do not know whether the action commenced by them is the logical one or not.

Thus, the troops begin an engagement in complete ignorance:

(1) Of the enemy's situation.

THE FIELD ARTILLERY JOURNAL

(2) Of the situation of their own army.

Therefore, their action must be deemed in the highest degree unsafe:

(1) From a tactical standpoint—because of the danger they run of attacking a greatly superior force.

(2) From a strategical standpoint—since the battle may be fought *where* the Commander-in-Chief does not wish it; *when* he does not wish (he has had no time to prepare a battle) or *in a manner* other than he wishes it.

Such a battle is unforeseen, improvised and altogether impossible to conduct. The result is bound to be fatal if one is confronted with an active adversary. In short, any action based on poor strategy will end in disaster unless the decisive arguments of superior tactics are invoked to save it.

As we will see, events abundantly support the truth of these remarks. If we point them out before they are described it is because certain results can be clearly foreseen. When we construct a theory we must be careful to estimate what its effect will be when it is put into practice. Certain consequences follow inevitably from poor organization. And these consequences are quite definitely disastrous—we reap only what we sow—a pear tree will bear only pears. No matter whether the conditions of its growth are favorable or not, one thing is certain—it cannot be made to produce apples.

Let us therefore admit once and for all the superiority of the system of Napoleon with its advance guards, which not only guaranteed the maximum effect of his attack, but also assured him complete security; for they permitted him to engage the enemy where and when he wished, with abundant information upon which to base an attack. Such advance guards are organized to gain information, to attack, to fix the enemy, to offer resistance, to maneuver in a retreat.

Let us not forget 1806.

If, after studying Moltke's projected and partially completed maneuver of 1870, we examine the kind of a maneuver the Germans write about in 1900, we find that their conception has not changed.

York von Wartenbourg has written at length of the difficulties

THE CONDUCT OF WAR

which would attend the execution of a Napoleonic maneuver under the conditions imposed by modern war.

Von der Goltz believes in the impossibility of the Commander-in-Chief exercising any effective guidance. His conclusion is that the function of directing the movements of units will inevitably pass to the commanders of tactical advance guards; he says:

"With masses in movement over an extended front, the chances of an unexpected encounter with the enemy at some point along the march are very large. When this occurs the neighboring units will eagerly join the engagement, and the result will be a decisive action on terrain not previously selected, and at a time when such an action is altogether undesirable. Thus the Commander-in-Chief is least in command of his forces, is most subject of the caprices of fortune and has to submit to circumstances beyond his control during the most important phase of war—combat and battle. He will ordinarily have a *fait accompli* (a battle already begun) to deal with, and the news of the battle will generally reach him only after his troops are committed to action.

"This lack of influence of the Supreme Commander over the commencement of the decisive actions and tactical crises of the war, is one of the main causes of difficulty in modern warfare. The most skillful plans are often set at naught and the most exact calculations are thus defeated. The objection may be raised that the wishes of a commander are known and observed by all, but the fact is that in war it is impossible to foresee everything. Each one can guide his actions only by such random gleams of light as appear from time to time to dissipate a part of the surrounding darkness."

When brought face to face with this condition of weakness admitted by the German theorists, this denial of the function of command to the Commander-in-Chief, who is thus forced to submit his will to the chance decisions of lower commanders, who in turn are in total ignorance of the situation—how infinitely superior appears the theory of Napoleon: The theory which, while preserving inviolate the Commander-in-Chief's function of command, prevents all chance of his calculations miscarrying and guarantees them against the operations of the enemy and the

THE FIELD ARTILLERY JOURNAL

hasty action of his own troops. His forces are restrained from injudiciously commencing an engagement until the desired moment arrives, and a certain duration of time is thus given to the random gleams of light by the permanence of the system of security which remains in the hands of the Commander-in-Chief, and makes it possible for him to retain effective control over all battle operations.

Colonel Bernhardt, in agreement with Moltke's idea, seeks to improve it by a more elaborate preparation in order to render its success more overwhelming. He writes as follows:

"Preparations in time of peace must ordinarily be carried further and prepared in more detail than is the case today.

"Once the concentration is finished, an offensive of maneuver must be launched with the swiftness of lightning; it must proceed to its conclusion with the inevitability of a logical syllogism. In order that this may be done the offensive must be prepared and studied with the greatest care and march tables worked out in advance.

"These preparations will produce, in the event of war, their maximum effect, and this effect will be in the highest degree characteristic of modern warfare.

"The general plan must no longer concern itself with the preparation of a concentration which takes into account all the various maneuvers which may be foreseen or executed and reserves its decision (the choice of what maneuver is to be carried out) until that moment when, after the concentration, full information is received regarding the enemy situation and movements. Such a procedure was still possible in 1870, but today the basis of concentration must be a plan for conducting operations in a direction fixed in advance. Moreover, these operations must be so rushed (by preparations made beforehand with the idea in view of gaining time) that the enemy in spite of all his efforts will be forced to submit to the initiative thus gained."

The German concentration of tomorrow is thus emphatically *not* a reunion of forces with several possible ends in view. It aims, rather, at a maneuver, framed *a priori*; an attack, prepared in advance in all of its details (direction as well as means). This attack will be preceded by a careful preparation, which will

THE CONDUCT OF WAR

permit the offensive to be made with such force and energy as to guarantee the initiative to the attacking party, and to bring about the defeat of the adversary. Such a maneuver represents one continuous unbroken effort to gain and hold the direction of the war from the commencement of hostilities. But no matter to what lengths this advance preparation is carried, the maneuver, to be successful, to lead to the military results demanded of it—that is to say, the defeat of the enemy—must be conducted with skill and, above all, with accuracy. Therefore, it cannot be conducted at random, it must have the benefit of all available information. If it be prepared in advance and its direction fixed *a priori*—still, we must insist, the direction fixed upon must be the right direction—that direction which will produce the results sought, a decisive victory. Without this result and unless the maneuver is based on sound judgment both speed and initiative are valueless.

Nothing of this sort was possible for the Prussian armies in 1870, or for Moltke, their Commander-in-Chief. Because the French had prepared no definite plan of concentration before the war, the German concentration had to be made for several contingencies. Moltke being ignorant of what form the French concentration would take was therefore forced to wait until this concentration was finished before he could act.

The problem of the German General Staff of 1900 is a different one. All of the foremost states of Europe now have plans of concentration which will be put into effect immediately following a declaration of war. These plans are plainly visible on the terrain and take the shape of railways and loading ramps, etc. Their outline is decipherable also in certain preparatory measures which are in process of execution during peace-time. These plans have also in many cases been either wholly or partially committed to writing and, being more or less known, make it possible to reconstruct the plan of concentration of a potential enemy state.

"Preparations for war cannot in their entirety be kept secret. They are made, of necessity, within full view of everyone, and it is thus easy to perceive what forces will be employed. Certain particulars are, indeed, kept secret, but in spite of this it remains

THE FIELD ARTILLERY JOURNAL

true that a general idea of the whole plan can still be gained by careful study." (Colonel von Bernhardt.)

Colonel Bernhardt thinks that a maneuver prepared in advance and executed with such promptness as to take full advantage of the element of time is also bound to hold good with regard to considerations of space. He supposes that, because his maneuver is based on an accurate knowledge of the enemy's concentration, and because it is launched in the right direction and in accordance with the details known or inferred, he has satisfied every condition necessary to guarantee the success of such rapid operations.

A similar conception may be observed in the application to strategy of the idea carried out by Frederick the Great in tactics which involved the employment of the oblique order of battle—an attack, every detail of which was rigidly fixed in advance and calculated to outstrip the enemy's dispositions by the speed with which it was launched. The military theory of Prussia is apparently unable to escape from this conception. This idea, nevertheless, breaks down both with regard to strategy and tactics when confronted with the conception of Napoleon; when confronted, for example, with an army maneuvering strategically and tactically with the end in view of creating a surprise. And let us remember that the element of surprise can only be imparted into modern warfare by the execution of an indeterminate concentration which cannot be discovered beforehand by any enemy system of espionage, inasmuch as the location and objective of such a concentration are decided upon only at the last possible moment. A concentration of this nature permits the employment to the limit of their capacity of all mechanical and material means, especially railroads and, so developed, it attains an elasticity up to the present impossible in war.

The conditions that limited the concentration of 1870, making it less flexible than that of Napoleon, determined also its form and its location in space. This limitation resulted in an insistence on economy of time which caused all railways leading to the frontier to be used for the transportation of troops. These railways were widely separated and of small capacity. Their employment

THE CONDUCT OF WAR

on the scale planned was altogether a new departure in warfare.

Today this no longer is the case.

Military necessity has caused the construction of strategical railways. The needs of commerce and industry have increased the number and carrying capacity of all commercial lines. Every part of the country can now be reached by rail and the number of double-tracked lines is very large. The use of railways in military operations, particularly in grand maneuvers, has become a matter of routine, and there is now a very close relationship and understanding between all railroad companies and the general staffs of armies.

But still it is no longer necessary to make use of all the railways leading to the frontier—there are enough of such railways to meet and more than meet any military demands put upon them. This makes it possible to combine the use of railways in various ways in order to achieve the results sought.

The high type of railway personnel now employed makes it possible to defer until the last moment the execution of plans dealing with the distribution of forces in space.

The situation today differs from that of 1870 in that it is now possible to execute a last-minute concentration of the Napoleonic type. The element of surprise can thus be introduced into modern warfare, especially if road marches are resorted to in conjunction with the elastic use of railways outlined just above.

An offensive conducted in this manner would throw out of axis the enemy's concentration, and displace the center of gravity of his army, causing him to compress his forces to the right or left in a closer formation than originally contemplated, and would make possible the launching of an attack in a quarter where he least expected it. It is a fact that many such operations may be planned and studied in time of peace, any one of which may be put into execution at the outbreak of war.

From the point of view of the defensive this theory would make possible a sudden and unexpected parade of considerable forces in the face of a hostile offensive.

To sum up: a concentration conceived and executed in this

THE FIELD ARTILLERY JOURNAL

manner would, whether the situation were offensive or defensive, have the effect of strategic surprise inasmuch as the enemy would in either case find himself confronted with dispositions other than he had been led to expect. Such a concentration would be capable of dealing with any maneuver no matter how quickly executed. Once a decisive attack became disclosed, it could oppose it with a feint and a counterattack with every chance of success.

It is in such a manner that Napoleon's conception of surprise in space as well as in time must be adapted to XX century warfare.

The superiority of the Napoleonic conception to that of Bernhardt is evident. Bernhardt would accomplish a strategic surprise by exploiting the element of time only. He insists on rapidity of execution and to this end he advises a minute and careful preparation of plans in advance; but he fails to take into account the other elements, particularly that of space, necessary to such a maneuver.

In rebuttal it is easy to talk about rigidity of railways and the mechanical conditions underlying their use, as well as their unsuitability for military purposes. Only the future can determine their limitations. Properly handled, they have up to the present complied with every demand made upon them.

Remember that the German concentration of 1870 went far beyond the prophecies made by Jomini in 1866.

After all, there can be no comparison between the following two systems of strategy:

(1) One of which, insisting on a concentration prepared in advance and therefore known to the enemy, makes a thrust straight to the front.

(2) The other executing a concentration in accordance with a decision made at the latest possible moment; then and then only deciding which one of several prearranged schemes of transportation is to be used to place an army of maneuver in a suitable position either

To make a decisive attack, or
To counterattack.

(End of Part I)

GREAT COMMANDERS OF THE FAR EAST

BY MAJOR W. H. CURETON, F. A. (D. O. L.)

THE purpose of this article is to bring to the attention of our service the wonderful achievements of a few characters who have thus far been given small space in most of our histories, and to stimulate interest in studying the campaigns of certain of these men, whose military exploits at least equal, if they do not surpass, the deeds of Napoleon, Alexander and others whom we are in the habit of calling the Great Captains.

Space permits the inclusion of but a few great leaders from the confines of Asia, and the truly great ones are not lacking in numbers.

Among those Eastern commanders there are unquestionably three who stand unexcelled. First, the Great Mongol, Temudjin, known better by his title of "Genghis Khan", next his chief of staff and general, Subotai; and last but not necessarily least, another great conqueror who followed over a hundred years later, the Tatar Timur, known as "The Iron Limper", or "Timur the Lame", sometimes called "Tamerlane".

Before launching into the various campaigns of these great leaders, it is perhaps apropos to bring out the fact that popular (Western) conceptions of the events soon to be described, particularly those of the XIII and XIV centuries, have for the most part been distorted by the chroniclers and churchmen of Europe who lived at that time. Unable to salve their own consciences or to maintain desired prestige over the masses by truthfully explaining the many crushing defeats meted out to the flower of their knighthood, these bards and so-called historians sought by subterfuge and falsehood to hide the wonderful conquests of able leaders and excellent troops behind the time-worn excuses of superior numbers, brutality, and punishment by divine providence for sins either real or imaginary.

As a result, there is, even at the present time, a general lack of knowledge concerning many important events of those two centuries; many happenings of that period which were given great space in the Western histories of the times and thus

THE FIELD ARTILLERY JOURNAL

brought down to us of the English speaking races, were, as a matter of fact, but minor occurrences when compared with the stupendous Westward movements of skilled armies from the East led by men, the very mention of whose names cast fear and despair into the hearts of all European peoples.

There is a tendency among men whose education has been that of Western Europe and the Americas to think of European history as only the history of Latin and Teutonic Europe. There is a failure to take notice of the Mongol, Tatar and Turkish invasions, which produced a far more profound and lasting impression than did the crusades which occurred about the same time. It is this lack of knowledge which accounts for such ridiculous statements as were frequently made during the Russo-Japanese War to the effect that for the first time in over a thousand years Asia had been victorious over Europe. The truth is the recent military supremacy of the Western races dates back only some three centuries. From the XIII to the XVII centuries the Mongol, Tatar and Turkish Armies, almost uniformly proved their superiority over European foes, being always the invaders, and most of the time the conquerors. No military leader of their days performed such exploits as did Genghis Khan, Subotai, Timur, Bajazed, Bayan and others.

By the end of the XII century Europe had lost all fear of aggression from either the South or East. The Moors had been defeated in Spain and their power was on the wane. The crusaders were still engaged in the Holy Land, and the poets were singing the praises of Richard the Lion Hearted, who had but shortly before returned from a supposedly successful expedition against the infidel.

Barbarosa had defeated the Seljuk Turks in Asia Minor and Jerusalem was on the point of capitulation. In Russia the countless principalities of Rurik's descendants were organized into a sort of confederacy, and had already started that slow extension eastward which has continued through the ages to the present century.

Poland was a kingdom of major importance, and Hungary was probably the greatest military power of all Europe. The

GREAT COMMANDERS OF THE FAR EAST

Chinese were the monarchs of the East and were certainly more advanced than any European nation, both in culture and military organization. The kingdoms of Hia and of the Uigars were probably as important as any state of Western Europe, and Karismia was rapidly developing into the young colossus of the time.

CHIEF POLITICAL SUB-DIVISIONS OF ASIA AT BEGINNING OF XIII CENTURY



Into such a world suddenly appeared the Conqueror.

Early in the XIII century the Mongols, an obscure nomadic tribe from the vicinity of Lake Baikal, under their leader Genghis Khan, conquered practically all of the nomadic tribes of Asia, overran part of China and then swept to the South and West as far as the Indus and the Caspian. Genghis Khan left this vast domain to his son Ogotai, and to his other sons he gave dependent provinces. This continued for generations until gradually these dependencies succeeded in breaking away from the ruling house, due to jealousies and bickerings among the descendants of the Great Khan. These in turn broke up into still smaller fragments, until finally the remains were broken or absorbed by the new empire of the Tatar Timur, and upon the latter's death dissolved

THE FIELD ARTILLERY JOURNAL

into the numerous fragments which one still finds in interior Asia.

While it may seem that these people brought into the world only destruction, such is but half of the truth. What was destroyed was in need of obliteration and what followed was a renaissance throughout the world, an interchange of ideas, the opening of trade between East and West, the introduction of superior eastern civilization into Europe, and the discovery of America.

GENGHIS KHAN

Genghis Khan was born in 1162. The early years of his life were spent in conquering the numerous tribes around Lake Baikal which had broken their allegiance to him, when as a boy of thirteen he inherited the tribal rights of his father. By 1206 this had been accomplished, and at the age of forty-four he found himself ruler of over 2,000,000 Mongol and Turkish peoples.

North of the Gobi Desert he had by this time subdued all the turbulent and lawless tribes that stretched from the Irtish to the Khinghan mountains. All his rivals had been destroyed and in the Spring of 1206 he summoned a Kuraltai, or grand council, near the sources of the Onon; on this spot was planted a standard composed of nine white Yak-tails (one for each of the nine chieftains who had stood by him in his hours of distress); around this were collected the chiefs of the different tribes. A priest then came forward and declared solemnly that having conquered so many "Chief Khans", he could not adopt that humbled title, and that Heaven decreed to him the title of "Genghis Khan," or the "Mightiest of Khans". He was then saluted under that title by the different chiefs, and thereafter so called.

From 1206 until 1211 Genghis spent his time in consolidating conquered territories, in subduing the kingdom of Hia, and in perfecting the organization of his army.

For years the Mongols had been vassals of the Kin Empire and yearly tribute had been exacted from them. In 1208 the Kin emperor requested Genghis to furnish him two tumans, 20,000 men, as assistance in a campaign against the Sung Empire. Genghis gladly accepted and not only furnished the quota desired, but officered it with the flower of his army. Its leaders

GREAT COMMANDERS OF THE FAR EAST

were Chépé Noyon and Subotai, concerning both of whom more will be heard later. This campaign was not a severe one, but was of untold value to the Mongols. Upon its conclusion Chépé and Subotai, with their commands, spent months roaming throughout the Kin Empire, familiarizing themselves with the terrain and sowing the first seeds of what was later to be the well-nigh perfect intelligence system which characterized all of Genghis Khan's operations.

In 1209 a new emperor came to the throne of the Kin empire and the usual embassy was sent to Genghis for tribute. The great Khan's answer was characteristic of the man. He scornfully told the envoy that the "Son of Heaven" ought to be an extraordinary person, but was an imbecile like Chongliou worthy of a throne, or should he, Temudjin, abase himself before him? Whereupon he kicked the envoy out of his tent.

Matters came to a head in 1211.

Having left his son-in-law, Thugadshar Noyan, with a detachment of about 2,000 men to keep a watch on the newly conquered

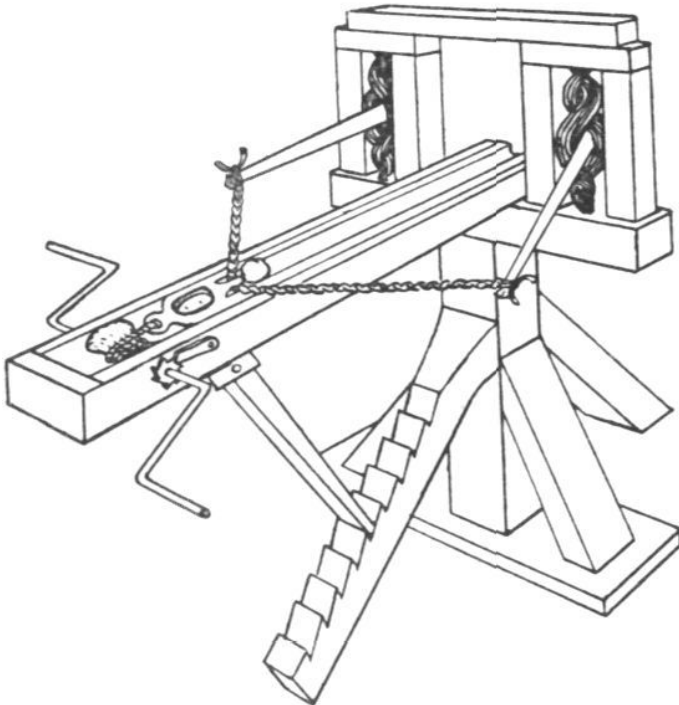

LIGHT ARTILLERY (CATAPULT)

THE FIELD ARTILLERY JOURNAL

tribes, Genghis set out in March, 1211, from the river Kerulon with a force of about 90,000 men, formed into three corps, each composed entirely of cavalry divisions. His four sons accompanied him. He first crossed the desert of Gobi, which then bordered the Mongol tribes on the south, and then came to the province of Shansi, whose northern frontier was protected by the widely celebrated Great Chinese Wall. The Onguts tribesmen, who garrisoned the wall, had been previously bought over by Subotai and opened the gates to the Mongols.

The Kin army numbered around 400,000 men, spread out over the northwestern provinces of the empire. A number of the smaller towns were quickly taken by Genghis, the large city of Fuchau was captured by a clever strategem, and Chépé took Liao Yang by assault. However, when it came to the most important and strongly fortified cities, like the capital, Genghis found his organization insufficient for the task. Without artillery, infantry and engineers, he wisely saw the futility of besieging strong fortresses, so he adopted the policy of investing lightly the main towns and, using his army as a magnet, picked off in open warfare each of the relieving Kin armies as it came into his theater of operations, until by 1212, except for fortress garrisons, the Kin field armies had passed out of existence. When this occurred Genghis withdrew to the Kerulun and reorganized his forces.

It might be well at this time to use a few moments in explaining the results of this reorganization and in mentioning certain points of interest concerning the Mongolian equipment, tactics, transportation and system of supply.

The organization of the army was on a decimal basis.

The basic cell was the squad of 10 men. Ten squads formed a troop or company; 10 troops formed a regiment; 5 regiments a brigade; and two brigades constituted their fighting unit, the tuman or division of 10,000 men which could act as an independent force. The corps was made up of several tumans, usually three.

In addition there was a tuman d'élite, The Guard. This unit was usually kept in the hands of the Commander in Chief, and in addition to being available as a general reserve, furnished the

GREAT COMMANDERS OF THE FAR EAST

necessary messengers and communications personnel for headquarters, hard riding men whose services, supplemented by the frequent use of carrier pigeons, never failed to keep the Khan and his generals thoroughly in touch both with the capital and with the various elements of the army.

Mounted infantry now made its appearance in the Mongol ranks and soon reached an efficiency on foot surpassed by no Asiatic or European foe. They were adept at quickly dismounting and making full use of their weapons. They would then agilely spring up behind horsemen sent forward for that purpose, and thus retain freedom of action.

At this time Genghis also formed a corps of artillerists and engineers, about 30,000 strong.

For protective equipment the Mongols had an armour of tanned hide, lacquered to make it more durable.

The weapons consisted of a lance, lariat, a curved saber, suitable for either cutting or thrusting, an ax, and two bows, one for firing on horseback, the other of larger size and greater precision used by the infantry and possessing an effective range of well over three hundred yards. Three quivers were carried by each man, each with a different caliber of arrows for the various ranges.

The artillery consisted chiefly of ballistas, corresponding to light howitzers, and catapults, flat trajectory weapons. These were taken to pieces and transported as pack artillery. They could fire rapidly and accurately, could go anywhere and were adequate for open fighting. The huge ballistas and catapults necessary for siege work were transported in high-wheeled carts, or constructed on the ground when requirements of mobility did not permit the carts to accompany the fast moving columns. The heavy artillery fired huge stones often exceeding a ton in weight. The light artillery was considered effective up to twenty-five hundred yards.

Each soldier carried a complete set of tools, shelter tent, individual camp-kettle, and a water-tight bag which contained needles, thread, and change of clothes. This bag could be inflated for use in crossing rivers. The iron ration carried by each man was in two leather bags, one of which contained a sort of cottage

THE FIELD ARTILLERY JOURNAL

cheese and the other a small portion of flesh food. Immense herds of cattle and horses were driven in rear of the army, there being at least three horses for every two men. No grain was transported for the animals, as they had no food save what was found as they traveled. The cattle herds were more of a luxury than an absolute necessity, for the Mongol soldier was trained to campaign for days at a time with no food except that carried in the two leather bags. The reason that this was possible is as follows: as far as conditions permitted practically all the mounts used in the field were mares which provided the milk necessary for making the cheese carried as the major portion of the iron ration. So, his means of transportation, the horse, not only made Genghis Khan's armies the most mobile the world has ever seen by reason of that animal's natural speed, but also provided food for the men, making them independent of supply trains.

The tactics of the Mongols were very flexible in execution. The different maneuvers were directed by signals, each troop using a number of black and white flags for that purpose, while the higher commanders had standards of various design depending on their rank. Thus the delays caused by long orders and messages were obviated. Contemporary observers were impressed above all by two features, first by the speed, silence and mechanical perfection of their evolutions, second by the accuracy, range and volume of the Mongol fire, both of the arrows and the artillery.

In battle the squadrons were deployed at wide intervals and, in order to make effective use of those turning movements at which Genghis Khan and his successors were so adept, the troops comprising the wings of the battle line were frequently moved into positions far beyond the flanks of the battlefield. Strong reserves were held in hand by all units above the troop, ready for prompt counterattack or exploitation of the slightest success.

When surprise was not possible of attainment, their attacks were generally preceded by an intensive artillery preparation.

The Mongol force worked with clocklike precision and possessed such fire power, shock action, and mobility that it

GREAT COMMANDERS OF THE FAR EAST

was irresistible to troops far more strongly armed and numerous. When, in addition to these factors, a general of Genghis Khan's caliber was ready to lead them, it is no wonder that these Mongols gained the greatest successive and unbroken string of victories that history has ever recorded. The Chinese of the time, who certainly had every reason for hating Genghis, in spite of their bitterness, were forced to admit in their chronicles that, "He led his armies like a god."

Genghis now felt prepared to strike the Kin Empire in earnest and in 1213 again took the offensive. By 1214 ninety large cities had been taken by assault and in all that vast country only nine places escaped ruin through self defense. The list of Mongol victories and conquests from 1213 to 1216 is so extensive as to become almost monotonous. Suffice it to say that by 1216 the power of the Kin Empire was broken and Genghis returned to Karakorum with the bulk of his forces, leaving one of his ablest generals to complete the conquest.

The Great Khan then turned his eyes to the westward. The Karismian Empire at this time was one of the most thickly populated and powerful regions of the world. Intensive irrigation based on the Amu and Syr rivers made the country, now so bare, most fertile. Samarkand was then the business and intellectual center of the world, with a population of around 1,800,000. Bokhara was over a half million in size, Urganj, near the modern Khiva, and Herat were over a million, while a score of others went into the hundreds of thousands.

For some time Shah Muhammad, the Karismian ruler, had looked with apprehension upon the sudden rise of the Mongols, and in 1217, due to the murder of Genghis Khan's envoys in Otrar by order of Muhammad, war became inevitable. As usual, the Mongol intelligence service had been operating in Karismia for some time, and by the end of 1217 the whole country was covered with a network of spies.

In the spring of 1218, Genghis set out with an army of about 130,000 from Karakorum and summered on the Irtish, where he established huge remount depots and conducted intensive training for his men.

THE FIELD ARTILLERY JOURNAL

GENGHIS KHAN'S KARISMIAN CAMPAIGN

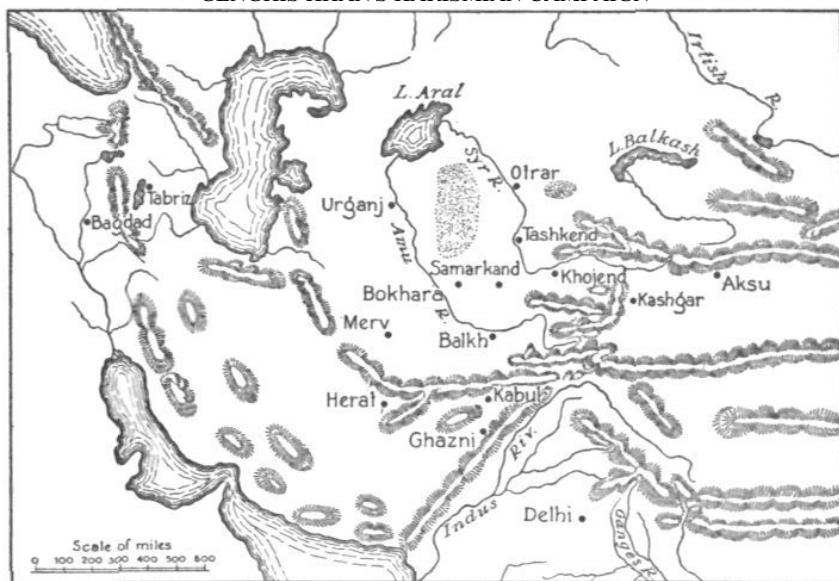

Before leaving that vicinity, in order to clear his left flank of the Uigurs, who had lately been troublesome, the Mongol Khan dispatched Chépé with two tumans against the Uigur Kingdom. Departing promptly, Chépé won several major engagements, and by winter had driven the Uigur prince clear over the roof of the world into Toufan, captured him, and cut off his head, which he sent as a souvenir of the affair to his master. Chépé then wintered at Aksu. This position of Aksu should be noted, as its selection was a previously planned detail of part of Genghis Khan's general plan of campaign.

Late in the summer Juchi, the eldest son of the Khan, was dispatched with three tumans on a raid along the Syr, in order to stir up the border people and mislead Muhammad. Juchi laid waste to all the territory between Ortrar and the Akkum desert. Muhammad hurried forward with 60,000 men and the two forces came in contact. Juchi, against the advice of his staff and although he had been warned by his father against being drawn into a major engagement, promptly attacked, and while partly successful, was nearly cut off from the main army, darkness being the only thing that saved him. Under cover of darkness

GREAT COMMANDERS OF THE FAR EAST

he withdrew, falling back over fifty miles before daybreak. Muhammad did not pursue.

For several months there was no further move; the Shah prepared his plan of defense and mobilized nearly 200,000 men.

Early in the Fall Genghis moved on Otrar, the key to the Transoxiana region, that is, the territory north of the Amu, and invested that city late in November, 1218, with three tumans, reinforced by the necessary auxiliary troops. Eighty thousand men he held in general reserve for his own future use.

Muhammad moved forward to repel the invasion and had advanced about two-thirds of the distance from Samarkand to Otrar when he suddenly received news that the enemy was debouching from the mountains on Khojend, beyond the right flank of his strong defenses along the river line, and only two hundred miles from Samarkand. This was Chépé. Turning, the Shah marched to meet this new danger, and had arrived at Samarkand when information reached him that Genghis had struck at Tashkend. This was a force of three tumans under Juchi which Genghis had dispatched from the reserve as soon as he heard that Muhammad had been drawn to the south by Chépé's diversion.

The Shah then did not know what to do, and made the fatal mistake of attempting to defend the whole length of the river line by being strong everywhere. Reinforcements were sent to Otrar, Tashkend and to Khojend. Twenty thousand men were sent to Bokhara and with the remaining 110,000, Muhammad locked himself up behind the walls of Samarkand.

Otrar fell around the end of April, 1219, and with it over 50,000 men, all of whom were put to the sword in retaliation for the murder of the Mongol envoys.

Genghis then directed Juchi with his corps to mop up the towns along the right bank of the Syr; Zagatai, another son, with three tumans to operate up the left bank; and Chépé to take Khojend and then effect a junction with the two princes. These operations were completed around the middle of May and the three corps just mentioned joined hands and prepared to converge on Samarkand.

The Shah was not unduly perturbed at this, feeling that the

THE FIELD ARTILLERY JOURNAL

fortifications of Samarkand were of sufficient strength to hold out for months, during which time reinforcements then being raised could arrive from Khorassan. But suddenly the news reached him that Genghis Khan was at the gates of Bokhara, in his rear, and squarely across his lines of communications.

This is what had happened. Having crossed the Syr, and masked by the corps advancing from Otrar, Genghis at the head of 50,000 men disappeared into the hitherto considered impassable Red Sands Desert. This desert was about one hundred and fifty miles wide and over three hundred miles long. By this move Genghis gained complete secrecy until the moment when he debouched at the southern end of the desert and was almost at Bokhara—directly in rear of the Shah's defensive system.

On the 11th of June, Genghis Khan arrived at Bokhara and the city fell without resistance. Only tarrying there for about two hours the Khan pressed on towards Samarkand by forced marches.

By this brilliantly conceived and executed turning movement, the Shah's whole line had been turned and his communications severed. Demoralized, he fled and left the garrison of Samarkand to its fate. Probaby never in the history of war have successful applications of the principles of surprise and movement been so conspicuously illustrated.

Detaching Subotai and Chépé with two tumans in pursuit of Muhammad, the siege of Samakand was started. Over three thousand ballistas, catapults, and flame throwers of large caliber were placed in action; the miners and sappers continued their operations day and night and soon the doomed city fell.

In six months Genghis Khan had destroyed the field armies of Muhammad, and overthrown the great Karismian Empire.

The remainder of the campaign was devoted to the siege and capture of all the principal cities and to thorough subjugation of the country. It is practically a repetition of the last stages of the campaign in China. By 1222, Mongol control was everywhere supreme, as far south as the Indus.

One point of interest, however, is in following briefly the actions of Chépé and Subotai. They pursued the Shah relentlessly until finally the latter, deserted by all his followers, died in

GREAT COMMANDERS OF THE FAR EAST



HEAVY ARTILLERY
(BALLISTA)

poverty and distress on a small island in the Caspian Sea. Subotai then obtained permission to make an advance into Russia. Chépé and he then forced their way through the Caucasus and in six months had crushed the kingdom of Georgia. In the spring of 1222 they pushed on into south Russia, everywhere establishing a stable military and civil administration. Further, they organized with the Venetian merchants plying the Black Sea, an elaborate system of intelligence to discover the weak points of Europe. This aid from the Venetians was to prove of great value to Subotai a few years later. In 1224, the Mongol Corps completely destroyed a Russian Army of around 80,000 men, in a battle near the Kalka river. Being then recalled by Genghis Khan these two tumans marched around the Caspian and reported to the Khan. This victorious march certainly ranks among the most wonderful military exploits of history. A Turkish chieftain is said to have marched around the Caspian, and it is a certainty that one hundred and eighty years later Timur did the same thing; but in the last case the conqueror was the master of a mighty empire, while Chépé and Subotai only had 20,000 men under their command.

THE FIELD ARTILLERY JOURNAL

In making a hasty review of this campaign against the Karismian Empire the following stand out. Every move was apparently carefully planned toward gaining the ultimate objective, the defeat of Muhammad's army. A glance at the map shows the tremendous distances covered in short spaces of time by the mobile Mongol forces. The co-operation between the various corps is evident, each advance reacting to the advantage of the other columns.

In these brilliantly conceived and executed operations we see correct applications of practically all the principles of war, particularly those of the objective, cooperation, economy of force, surprise, and movement.

(To be Continued)

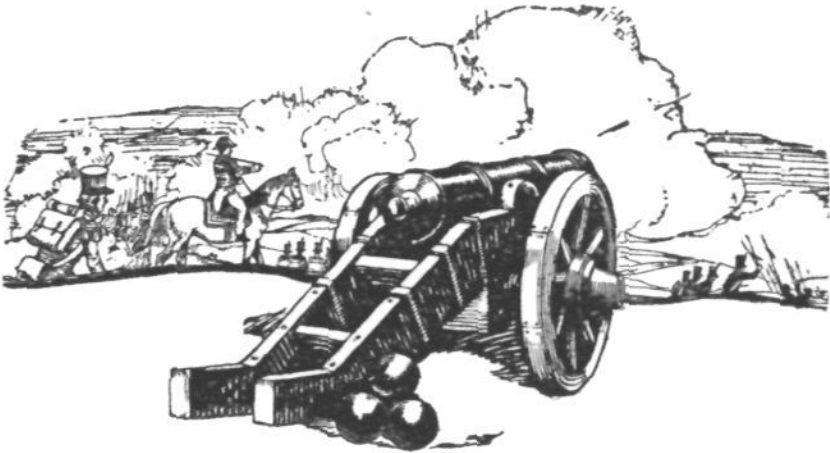

FOREIGN MILITARY JOURNALS A CURRENT RÉSUMÉ

Revue Militaire Francaise, July and August, 1929

LIEUTENANT-COLONEL VAUTHIER concludes his article "Anti-Aircraft Defense of Large Units". In the final numbers, he discusses the feasibility of the use of Field Artillery weapons for fire against airplanes. This question presented itself at the beginning of the World War when the various armies had no special anti-aircraft weapons. In many ingenious ways they altered Field Artillery matériel for use against airplanes. However, once transformed, this matériel was never again used for fire against terrestrial targets. During the war a few attempts were made to use Field Artillery units for temporary anti-aircraft fire, not, however, relieving them of their normal missions. The few attempts were not successful and in the end this policy was abandoned entirely.

Since the war, various armies have considered the use of Field Artillery for anti-aircraft fire, and Lieutenant-Colonel Vauthier, in his article, reviews several foreign opinions, particularly those of two English officers, Captain K. M. Loch and Major R. G. Cherry.

Lieutenant-Colonel Vauthier concludes that it is impractical to use Field Artillery against airplanes. The advocates of this idea advance the principle that the arm of the artillery is the projectile which should be as effective against an airplane as against a terrestrial target. In reality, however, the arm of the artillery is the cannon, a "machine-tool". The tool part is the projectile; the machine is everything else: the tube, the gun carriage, the traversing and elevating mechanisms, and all fire control instruments. In this assemblage the projectile occupies a preponderant part, but all parts are necessary to make the projectile effective. In the case of anti-aircraft fire the Field Artillery projectile is ineffective because the machine is inappropriate.

"We arrive, then, at this conclusion, that, to fire against airplanes, artillery matériel must have certain characteristics and special accessories; in other words, the matériel must have all

THE FIELD ARTILLERY JOURNAL

the qualities of a special anti-aircraft weapon. The conclusion at which we arrive for the light artillery is that, at the present time, we can assure anti-aircraft defense of large units only in giving them special anti-aircraft matériel. For the future, it will be possible to transform all light artillery guns into anti-aircraft artillery, which, in addition to fire against airplanes and fire against tanks, can be used for certain terrestrial fire on the condition it not be used for missions calling for direct support of the infantry.

"The transformation of light artillery could be made in two steps: (1) To attach a group of light anti-aircraft artillery to each army corps by replacing a group of heavy field artillery. This first step is urgent to provide the army corps with an anti-aircraft defense, which is actually lacking. (2) To attach to the division one and finally two groups of light artillery capable of firing on airplanes, tanks, and delivering certain types of terrestrial fire. These two groups will possess the only artillery *guns* (as distinguished from howitzers) in the division.

Lieutenant-Colonel Vauthier then proposes the following artillery organization:

In the division	{	1 group of light guns (for fire against airplanes, tanks, and certain ground targets)
		1 group of light howitzers
		1 group of heavy howitzers
In the army corps	{	1 group of light guns (for fire against airplanes, tanks, and certain ground targets)
		1 group of heavy guns
		1 group of heavy howitzers or mortars

In the general reserve—Anti-aircraft regiments.

"This complete transformation of the artillery of large units will require an adaptation of the command, hereafter responsible for the anti-aircraft defense of its units at all altitudes, and a transformation of the habits of the field artillerymen. It is probable that this new system of field artillery will not be a popular innovation. . . . However, the aerial danger exists, and no artillery system can be studied without considering the necessity

FOREIGN MILITARY JOURNALS

of organizing against airplanes in each large unit. This preoccupation dominates all study in foreign armies, and France is actually one of the few nations which has no anti-aircraft artillery attached to the corps or the division."

"From Liao-Yang to Moukden," by Lieutenant-Colonel Desmazes, is an account of the two principal battles of the Russo-Japanese based on a study of both Russian and Japanese documents. Most military students are familiar with Russian accounts of the war, but no Japanese documents have been translated into any European language.

In the first chapter of his article Lieutenant-Colonel Desmazes describes the personnel of the opposing armies. In 1904, Japan had 462,000 trained men in the active and reserve forces. As Japan, at that time, was not a rich nation, only 50,000 men were trained each year. These 50,000 were selected from a class of about 540,000. As a result, the Japanese soldier was the product of an incomparable selection. According to General Hamilton, the English Military Attaché, the Japanese soldier was: "the cream of the nation, warrior by taste and tradition, thinking little of the future . . . he is brave, robust, stoical in pain; and he carries, without weakening, an equipment which makes him resemble a Christmas tree."

The Japanese officer, well instructed, poor, living in intimate contact with his troops, possessing to the highest degree the same virtues as his men, was a soldier of the highest type.

The artillery was the weak spot in the Japanese army. The matériel was the 75 mm Arisaka, model of 1898, a compromise between a field piece and a mountain gun. It was light, but the draft was poor and it lacked mobility. It especially lacked power. These faults were compensated by the tactical efficiency of the Japanese artillerymen, who were very much superior to the Russians.

The Japanese soldier was well nourished. His ration consisted mostly of rice, but he also received meat, fish and vegetables. The field kitchen was carried on a stretcher, hung between two horses.

The medical service established a wonderful record during

THE FIELD ARTILLERY JOURNAL

the war. Officers carefully supervised the nutriment, water (men drank only boiled water), personal cleanliness and clothing. In spite of the severe climate, for the first time in medical history, there were fewer deaths from disease than from enemy fire.

In speaking of the Russian soldier, Lieutenant-Colonel Desmazes remarks that his value varied with his organization. The Siberian regiments were excellent; the European regiments were at first of lower quality. The concentration of reserves was made without method and the men were unacquainted with each other and with their officers.

The Russian officer was brave, well disciplined, and sturdy; but, in the lower grades, especially, he lacked initiative and was not interested in the welfare of his men. The intellectual level of the Russian subaltern was very low, due to the few advantages offered by a military career in Russia at that time.

"The French Artillery from 1914 to 1918" is the subject of a talk by Lieutenant-Colonel Aublet to a group of Swiss officers. He introduces his subject by quoting certain statistics which describe the development of artillery during the war. In August, 1914, the French army had four pieces of artillery to each battalion of infantry; on November 11, 1918, it had twelve. The proportion of artillery was thus trebled during the war.

At the beginning of the war the power of artillery fire was underestimated. It was admitted that as soon as the infantry penetrated into the zone of hostile fire, its progression could not be stopped by enemy artillery fire. It was only necessary to observe certain precautions: skirmish lines, squad columns, etc. Medical statistics had shown that losses due to artillery fire were inferior to losses by infantry fire. In the war of 1870-71, artillery fire caused 15 per cent. of the losses as compared to 80 per cent. by rifle fire. During the Russo-Japanese war, 11 per cent. of the losses were by artillery fire and 85 per cent. were by infantry fire. Between 1914 and 1918 the figures were respectively 67 per cent. by artillery against 23 per cent. by infantry fire.

In describing the progress in matériel, Lieutenant-Colonel Aublet states that, at the beginning of the war, the light artillery pieces were the 75 mm Mod. 1897, and the 65 mm mountain gun which had a short range and very limited power.

FOREIGN MILITARY JOURNALS

As heavy artillery the French had:

(1) The 155 mm howitzer (Rimailho), carried in two loads, having a range of only 6,000 meters.

(2) The 120 mm gun and the 155 mm howitzer (Bange), obsolete pieces with rigid carriages.

In addition to this matériel there were 11,000 old model Bange guns and howitzers stored in various arsenals. These pieces ranged in calibre from 80 mm to 270 mm, and for this matériel there were 4,700,000 shells. The metallurgic qualities and precision of these pieces were excellent. It is the opinion of Lieutenant-Colonel Aublet that "It was this matériel which saved France, permitting her to await the moment when the new matériel under construction would be available."

This new matériel was pressed into service progressively replacing the old-type weapons. However, it was not until 1917 that the new matériel was issued in large quantities. In 1917 on the Aisne, only 55 per cent. of the howitzers and 25 per cent. of the guns were new models. In 1918 there still remained 35 per cent. of the old matériel.

Revue D' Artillerie, July, 1929

An unsigned article, "**Field Artillery Aviation in the Battle of the Marne (1914)**" describes the assistance rendered in that battle by airplanes attached directly to a field regiment. General von Bulow made this remark shortly after the Battle of the Marne: "As for the French Artillery, I hate it." From the study of an immense number of German documents, it appears beyond question that the effect of French Artillery fire caused a similar reaction in the whole German army. Officers and men were in a constant state of panic, a condition concerning which the French had no real conception. The French were pointing out the superiority of the German artillery when the Germans themselves were overwhelmed with the superiority of their adversary's gunnery.

The success of the artillery of the French 6th Division at Montceaux was unquestionably due to the fact that its artillery was the only unit in the French army which had

THE FIELD ARTILLERY JOURNAL

airplanes actually assigned to it, as the result of the following circumstances narrated in the history of the 22nd Artillery:

On the 3d of August, 1914, command of the regiment was given to Colonel Estienne, the apostle of field artillery aviation, who brought with him from Chalons, where he was testing it, a light section consisting of two one-seater demountable planes built by Saint-Chamond and transported on automobile wheels.

Commanded by Lieutenant Morel, an artillery aviator, the section had as pilots Sergeant-Major Damberville and a well-known aviator of the period, Weymann, an American who had enlisted as a connoneer-private in the 22d Artillery.

The planes readily followed their regiment in all its displacements in Belgium and in its long retreat from Charleroi to the Seine, making flights on orders from the Army Corps, and from the artillery commander for the purpose of laying his batteries.

During the retreat on Laon, after an uninterrupted march of fifteen days, the 6th Division turned, and on September 6th, attacked Montceaux-les-Provins. Damberville, under instructions from his Colonel, took off early that morning and at about 8:00 A. M. brought back to the command post of General Petain, the Division Commander, a sketch showing the location of six or seven German batteries and a large force of infantry with reference to roads and steeples.

This sketch had been made in the air, on the tentative regulation sketching pad proposed in May 1914 by Colonel Estienne for use of artillery aviation units in field service. The Division Artillery Commander immediately caused copies of the precious sketch to be made and distributed them not only to his 75-mm. battalions, but also to a battalion of 120-mm. shorts in position on his left. This sketch enabled the French artillery, by its own means to rout an entire brigade consisting of both infantry and artillery.

Among numerous other examples which might be cited of the decisive intervention of artillery aviation at the beginning of the war, the following is especially noteworthy:

FOREIGN MILITARY JOURNALS

On the 8th of September, the artillery of the VI Corps, thanks to two planes piloted by Lieutenants Beaulier and Mingal of the 25th Artillery, silenced and then forced into hasty retreat a mass of artillery of more than eighty pieces which occupied positions between Beauzee and Sommaisne.

The author remarks that, in war of movement, the intervention of aviation will be truly opportune and effective only when the observer belongs to the artillery unit and has received a definite mission from its commander.

"Eyes! Eagle's eyes! We need them at any price, and, like the giant Polyphemus, formidable but blind, we raise our cry for them. No technical ordnance progress is comparable to that which artillery will attain when the airplane becomes part of its normal armament. We can and must take the initiative in that direction immediately.

"Two conditions must be insisted upon: First, the artillery aviation plane, on the ground, must follow the column. The aviator, being thus enabled to keep constantly in touch with the situation, will always be ready to carry out intelligently any air mission assigned him by his commander.

"Second, the artillery aviator must be a thorough artilleryman, directly under the orders of the colonel commanding the regiment to which he is attached.

"Field artillery aviation exists to no greater extent today than it did in 1914."

In his article "**The Use of Various Procedures in Unilateral Observation,**" J. Heriard-Dubreuil, Major of Field Artillery, presents in logical order a comparative outline of methods already adopted or under test.

It is particularly to be noted that lateral observation from a point considerably higher than the target area (plunging observation) is quite different from lateral observation from a point approximately on the same level as the area to be observed (grazing observation).

Observation of the first type is interesting, always to be sought after, and particularly advantageous. Everything prescribed in the French regulations regarding this type is

THE FIELD ARTILLERY JOURNAL

simple and correct, and it seems difficult to admit than an observer, even a novice, could be embarrassed in such a situation.

The really difficult type is the second, when observer and targets are on the same level. It is this case that is dealt with in considerable detail in the article, particular attention being given to graphical methods involving the preparation and use of charts.

From the point of view of precision, it can readily be noted that all the various methods are equivalent, differing mainly from each other in the number of rounds required, which necessarily is also a function of the data available regarding the relative positions of the target, battery and observation post.

As dispersion in range makes the lateral adjustment very costly in ammunition, effort should be made to utilize fully all data which may serve to reduce ammunition expenditure.

The article concludes with a brief discussion of fire for effect following adjustment with lateral level observation.

An article "**The Military Tournament of the Artillery 'Ecole d'Application'**" with illustrations, describes the horse show events which were held at Fontainebleau on June 15th of this year. The author, who states that this tournament has regained its place in the traditions of the School, notes with satisfaction that the younger generation of artillerymen will not permit a decline of the love of the horse which has such a fortunate reaction on military spirit, nor the love of sport, by means of which the field artillery retains that dash and vigor which increasing technical demands must never smother. One of the most interesting features of the show was the exhibition battery drill at the gallop.

R. Cheniverse, Lieutenant of Artillery (Reserve) in an article, "**A Rapid Method of Adjustment by Unilateral Observation**" describes his method of adjusting with lateral observation. It should be noted that his method involves the construction of a "yard stick" whose length is supposed to be exactly known and represents the map distance between

the point of fall of two rounds (or groups of rounds) fired with the same deflection, but with different elevations. This method only holds true however, or approaches sufficient accuracy, when the terrain is practically level in the area in which the rounds fall, and if dispersion does not enter to cause excessive errors in the results. The method therefore must be employed with precaution.

Other articles appearing in this issue are: "**Notes on Orientation by the Stars**" by L. Camps, Major of Field Artillery; "**Schneider 75-mm. Anti-aircraft Materiel—Light Field Piece,**" a detailed description, with table of characteristics and four illustrations.

The following article by E. P. Ricard, Major of Artillery, entitled "**Battalion Reconnaissance—The Preparatory Work of the Battalion Commander of Divisional Artillery**" is considered to be of sufficient interest to be translated. Certain tables and references are omitted in the following translation.

The French Training Regulations give certain decisions which the Battalion Commander must make upon completing his reconnaissance for battery positions, observation posts, command posts, plan of communications, plan of topographic work, position of the echelons, and the plan of supply.

These different decisions are naturally based on *The Mission*. But it is important to seek to accomplish this mission under the most favorable conditions. These most favorable conditions are themselves a function of *The Situation*. The Training Regulations "Artillery in Combat" enumerate them. But for any given situation, certain of these conditions take priority over others, so that in the final analysis, in order to choose between the different solutions, the Battalion Commander must be guided by a *priority of favorable conditions particular to the situation*.

Therefore, if it is desirable that the reconnaissance be made by all the officers of the battalion with the greatest sureness and hence in the most rapid manner possible, the Battalion Commander, before he leaves on reconnaissance, and after he has indicated the mission, should impart to his officers the

THE FIELD ARTILLERY JOURNAL

trend of the decisions he contemplates making at the end of his reconnaissance.

This orientation of the reconnaissance personnel constitutes the first part of the preparatory work of the Battalion Commander.

The Training Regulations prescribe that "in order that the reconnaissance be complete and rapid, the work must be divided."

The distribution of tasks is necessary, but it is not sufficient to produce rapidity, because actually the tasks of the different officers of the battalion during reconnaissance are not independent. For example the Orientation Officer and the Communications Officer will need to know where the Observer proposes to establish the observation post. Distribution of tasks is not enough; coordination is required.

Coordination must be arranged before leaving on reconnaissance. It constitutes the second part of the preparatory work of the Battalion Commander.

We propose to study this preparatory work by placing ourselves successively in the two situations considered in the Training Regulations.

1st Case: Time is ample for carrying out the reconnaissance.

2nd Case: Time is limited by the necessity of opening fire shortly.

It should be understood that the present study does not propose to give "an approved solution" to each particular case, but only to indicate the general scheme.

1ST CASE: TIME IS AMPLE

Examples of this case are the reinforcement of a stabilized front or the deliberate occupation of a position far from the enemy, either on the offensive or the defensive.

We shall study the following items in succession:

I. The explanation of the situation to the reconnaissance personnel.

II. The assignment of tasks.

FOREIGN MILITARY JOURNALS

III. The coordination of these tasks.

I. Orientation of the Personnel. (BY THE BATTALION COMMANDER.)

A. Instructions which can be derived from the *general situation*.

In the case with which we are concerned, the characteristics of the two situations (offensive and defensive) are, from the artillery standpoint, as follows:

Offensive

We can assume that our forces have superior means. The indication, therefore, is to seek the greatest power of which the batteries are capable, being satisfied with a minimum of security.

The offensive must be accompanied to the greatest possible distance by artillery fire; therefore the artillery must be placed as far forward as feasible.

There is reason to foresee the pushing forward of observation first, followed by the pushing forward of matériel.

Defensive

Inferior means are to be apprehended; therefore, while seeking power, the maximum security must be assured.

The mass of artillery will be deployed in depth. However, all the artillery will be able to fire beyond the line of resistance. It will be prepared to fire at the greatest ranges permitted by its deployment.

There is reason to foresee the falling back of the defensive lines, therefore, the falling back of observation, the withdrawal of batteries, and perhaps the batteries may even be attacked.

Ability to open fire immediately is indispensable and therefore certain means of liaison are required.

B. Instruction which can be derived from the *special situation*.

These orders relate only to the actual terrain of the operations. They result from a study of the map or from information gathered. They concern:

1st: The area of the gun positions. The area assigned to the

THE FIELD ARTILLERY JOURNAL

battalion for its reconnaissance must be subdivided among its batteries.

In every offensive situation each battery may advantageously be assigned a slice of ground parallel to the general direction of fire.

In a defensive situation, there will be assigned to batteries areas in depth, if the battalion has been ordered to dispose itself in depth; otherwise the procedure will be as given above for the offensive.

2nd: The location of observation posts.

3rd: The target area. Once the mission is given, the target area is at once derived. If the targets are located definitely, no difficulty is presented. Otherwise:

On the Offensive: For the 75-mm. For the preparation forsee fires close in to the infantry; for the attack, support of the infantry.

For the 155-mm. For the preparation forsee fires for destruction at 500 meters or more from our lines. Next, the covering of the crests (or terrain features) to the greatest possible range.

On the Defensive: For the 75-mm. Fires in front of the main line of resistance;

Fires in front of the outposts;

Fires within the position of resistance.

For the 155-mm. Distant fires.

Counterpreparation fires.

All targets should be indicated on the map. This study of targets has for its object the orientation of battery commanders regarding the minimum requirements of their fire, and also the orientation of the Observer regarding the areas to be observed from his observation post (or posts).

II. DISTRIBUTION OF TASKS

Since sufficient time is available, it is well to cause each officer to carry out the task which is normally his function. This normal distribution of tasks is set down in Regulations.

III. COORDINATION OF TASKS

Coordination must be arranged both as to time and as to

FOREIGN MILITARY JOURNALS

space. In order to avoid loss of time during reconnaissance, it should be worked out before departure.

Let us assume that in a battalion the normal method of reconnaissance is as follows:

The Observer and the Commander of the Echelon are given freedom of movement from the very start.

The Battalion Commander goes to the area of the positions with his officers. Upon arrival he releases the Orientation Officer to enable him to carry out his topographical operations, then goes rapidly over the area with his battery commanders, establishes liaison with the infantry (if necessity therefor exists) and with neighboring artillery battalions; returns to the batteries and there makes his decisions regarding the positions, the C. P., the work of the orientation officer on the positions and the general plan of communications. He then goes to the zone of the observation posts, accompanied by the officers who he deems necessary (in any event by the Communications Officer).

Assuming this scheme to have been adopted, the Battalion Commander must apply it concretely to the particular case and to the best interests of his officers, leaving no officer unemployed while awaiting the result of the work of others.

Let us take an example. The zone of reconnaissance for positions is very extensive, being spread out over several terrain features. On the other hand positions for observation posts are restricted to a limited area.

There will be every advantage in this case for the communications officer to begin his work at the observation post as soon as feasible.

All this will be materialized by an order designating a rendezvous point and establishing a time schedule for the reconnaissance.

IV. SUCCESSION OF PREPARATORY TASKS OF THE BATTALION COMMANDER

Upon receipt of the order for reconnaissance, the Battalion Commander will assemble his officers, read to them the order and orient them as far as possible, indicating to them:

THE FIELD ARTILLERY JOURNAL

Conditions relating to the general situation;

Certain parts of the special situation relating to the utilization of the terrain which will enable some of the preparatory work to be done by the officers of the battalion. (e. g. division of the area among the batteries; indication of the area of reconnaissance for observation posts; general plan of communications; topographical data, if required.)

The Battalion Commander and his officers will make a most careful study of the map, the Battalion Commander studying particularly the matter of targets and, if possible, establishing liaison with his groupment or with the infantry in order to obtain details concerning objectives.

The officers of the battalion are again assembled and the Battalion Commander gives them the latest information. He checks his entire preparatory work against that of his officers and receives their recommendations regarding carrying out the reconnaissance. He coordinates their recommendations, fixes the time schedule for the reconnaissance and designates a rendezvous point.

2ND CASE: TIME IS LIMITED

We shall assume two situations:

- (a) The reconnaissance is made behind a stabilized front.
- (b) It is made during a period of movement.

The *first situation* involves the rapid entry into line in an offensive situation (attack, counter-attack, engagement) or in a defensive situation (reinforcement of a defensive front). It becomes a matter of reconnoitering a *single position*. All reconnaissance personnel is available.

The *second situation* involves either:

A displacement during operations (approach march, gaining contact, exploitation, pursuit, combat in retreat). This may necessitate the successive reconnaissance of several positions.

A displacement during combat, to the front (displacement of artillery during the attack); or to the rear (withdrawal). This involves reconnoitering a *single position*.

Reconnaissance made during a movement is characterized

FOREIGN MILITARY JOURNALS

in both cases by the fact that it must be initiated during a period when the Battalion Commander and his captains can not leave their units forthwith in order to carry out the reconnaissance, on account of the uncertainty of the situation (displacement during operations), or because their units are still charged with fire missions (displacement during combat).

As a result, it is necessary to divide up the reconnaissance to a great extent and above all to make use of an advance reconnaissance detachment. This detachment will be charged with making a reconnaissance as complete as time permits.

In order to study the preparatory work of the Battalion Commander in situations where time is limited, we shall follow the same plan as before, examining the work from three points of view: Orientation of the reconnaissance personnel, division of tasks, and coordination of tasks.

I. ORIENTATION OF THE PERSONNEL

A. *Instructions resulting from the general situation.* The case where time for reconnaissance is limited, results, as we have indicated, from tactical situations varying greatly in nature. Each of these situations implies a particular tactical employment of the artillery. But the questions of tactical employment of our arm are, in general, the function of a higher command than that of the battalion. So that usually, for a battalion, the order for reconnaissance is based on one of the following conditions:

The rapid reconnaissance in an offensive situation.

The rapid reconnaissance in a defensive situation.

Whether or not it is a matter of rapid opening of fire, the characteristics of the situation are the same. In studying the case of ample time for reconnaissance, we have indicated the characteristics of an offensive and of a defensive situation.

On the other hand, the necessity of rapidly opening fire has a marked effect on the technique of the entry of the battalion into line. So that, comparing the case where ample time is available with the case where time is limited, we find for a given situation (offensive or defensive):

The same tactical characteristics of the situation.

THE FIELD ARTILLERY JOURNAL

Entirely different technical characteristics.

Thus it results that when time is limited, the general situation given by the Battalion Commander to orient his personnel will, in certain respects, be the same as for the case when time is ample, while in other respects it will differ completely.

B. *Instructions resulting from the special situation.*

These instructions are analogous to those which have been indicated for the case where time is ample; they designate the area of the positions, the observation posts and the target area. According to the time available to the Battalion Commander for his study, they will be more or less complete. The indispensable minimum will be:

The indication of the area of reconnaissance for each battery;

The indication of the area for observation posts.

It should be remarked that, for displacements of the artillery during the attack, usually the work can be prepared in advance and therefore can be thorough.

On the other hand, when it is a question of displacement during operations, involving at times the reconnaissance of successive positions, it is frequently necessary to restrict instructions to indications of a very general nature.

II. DIVISION AND COORDINATION OF TASKS

In the case where time is limited let us make a distinction between two assumed situations, one where the reconnaissance can be carried out by all the officers normally available for it, and the contrary situation where it is necessary to send forward an advance reconnaissance detachment. This distinction is necessary in order to study the distribution of tasks.

A. Under the first assumption, which resembles reconnaissance behind a stabilized front, the distribution and coordination of tasks will be carried out in the same manner as in the case where ample time is available. Coordination is even more necessary to avoid loss of time than in the case where time is limited.

FOREIGN MILITARY JOURNALS

B. Under the second assumption, which corresponds to a reconnaissance behind a moving front, it will be necessary to organize beforehand the advance reconnaissance detachment.

In certain cases, it will be best to send forward, in addition to the advance detachment, a detachment for route reconnaissance, because the assignment of this duty to the advance reconnaissance detachment would unduly overburden it in carrying out its difficult normal tasks. The advance reconnaissance detachment must reach its working area as soon as possible; it should not be required to follow an itinerary, much less explore routes. In the majority of cases, by reason of the particularly rapid work required of the advance reconnaissance detachment, the Orientation Officer and the Observer should form part of it. Route reconnaissance could then be assigned to a sergeant (75-mm. units) or to the Liaison Officer if available (155-mm. units).

Having organized the advance reconnaissance detachment, what will be the distribution of tasks among its officers?

For this study, we shall consider as before two cases, according as to whether a displacement is to be made during combat or during operations.

(a) *Displacement During Combat.* A single position is to be reconnoitered. Generally it has been possible to make a study beforehand. The remainder of the reconnaissance group will rejoin the advance detachment at the position.

In this case, it will be possible to divide the work between the Orientation Officer and the Observer. The advance detachment in most cases will have an idea of the time at which its work must be completed. This is a consideration of particular importance to the Orientation Officer.

In this case there is every reason for reinforcing the advance detachment with communications personnel and, on account of the necessity of pushing forward the ammunition supply at the earliest moment, to direct an advance reconnaissance by the Commander of the Echelon.

(b) *Displacement During Operations.* In this case the problem of the advance detachment is too extensive for the

THE FIELD ARTILLERY JOURNAL

Battalion Commander to try to divide the work among the members of the detachment. The fullest initiative must be left to the officers of the detachment. Their tasks will be invariably to move fast and to furnish an indispensable minimum of information on the following: area of the gun positions; reference marks in area for orientation; situation with respect to observation, with a general indication as to visible areas.

Moreover it will be advantageous to give the advance reconnaissance detachment the following instructions:

1st: The information to be furnished will relate not only to the area ordered to be reconnoitered. It must extend to positions permitting either improvement of observation, or occupation by the firing batteries, it being understood that the reconnaissance of such positions will be hasty and limited merely to an indication.

2nd: All information on the situation (front line, zones under hostile fire, etc.) will immediately be furnished to the Battalion Commander (hence the necessity of numerous messengers); each report rendered to show where the detachment is going and the time of sending.

CONCLUSION

In conclusion, we shall point out the essential difference which exists between the preparatory work of the Battalion Commander and the officers to whom reconnaissance duties are assigned.

While the officers of the battalion will exploit during their reconnaissance the preparatory work of a technical nature which they have done before their departure, the Battalion Commander will not directly utilize the greater part of his work, which has been both technical and tactical. His preparatory work was also for another purpose: "To assist his subordinates and cause them to grasp fully the ideas of the commander."

NATIONAL GUARD NOTES

Annual Armory Inspections, 1929

The results of the Annual Armory Inspections of the National Guard have recently been compiled in the Militia Bureau for inclusion in the annual report of the Chief of the Militia Bureau. These reports give an interesting picture of conditions in the National Guard during the armory training period at home stations.

A summary of reports on Field Artillery organizations being of interest to the Field Artillery personnel of the National Guard, permission was obtained to publish this data in advance of the issuance of the report of the Chief of the Militia Bureau.

The reports show that the actual strength of the Field Artillery of the National Guard during the armory inspection period was 2,645 officers, 46 warrant officers and 29,434 enlisted men and that out of this number, there were actually present at inspection or given credit for attendance 2,519 officers, 43 warrant officers and 25,053 enlisted men. Therefore, about 95% of the officers, 93% of the warrant officers, and 85% of the enlisted men were present or accounted for during the inspections recently concluded.

The reports also show that there were 68 officers, 3 warrant officers and 9,542 enlisted men who had less than one year's service at the time of the inspection, which is a marked improvement over 1928, especially for enlisted men.

The average strength during 12 months prior to inspections was 2,550 officers, 45 warrant officers and 30,737 enlisted men, and out of this number the drill attendance at an average of 47.4 assemblies for the same period was 2,397 officers and 21,641 enlisted men, or 94%, 95% and 74% respectively. This is an improvement over 1928 when the attendance was 87%, 98% and 67% respectively.

Unit mobilization plans were on hand in 664 organizations, while only 21 were found to be lacking in this respect. The

THE FIELD ARTILLERY JOURNAL

average rating given all units in discipline, morale and esprit was "Very Satisfactory."

There is a constant improvement shown in the armory situation each year as indicated by reports. At present there are 171 owned either by state, county or city, 16 by organizations and the remainder by private parties. Of the 363 armories reported, 301 have adequate facilities for training entire command, while 62 were found inadequate. Federal property is afforded adequate protection in 337 armories while 26 are lacking in proper storage facilities. The average general rating for the care and storage of property is shown to be "Very Satisfactory."

The matter of housing, care and use of animals is a difficult problem. However, there is a marked improvement being made as indicated by reports. There were 211 armories having adequate stables against 190 in 1928, while only 15 were reported as having inadequate stables against 23 reported last year. The average status as to care and use of animals is shown as "Satisfactory." Care and use of motor vehicles is also rated "Satisfactory."

Specific training objectives for the armory training period were set for 669 units while only 16 failed to have such an objective. A training objective for the entire year was set for 632 units, while 53 units failed to have an annual objective. This leads to a conclusion stated in the reports that 670 units had schedules, which would reasonably assure the attainment of the objective set, while only 15 did not.

The average degree of proficiency in basic training, both as to individuals and organizations was rated "Satisfactory."

It is very encouraging to note the figures given above as they represent a satisfactory condition and indicate a constant improvement in Field Artillery organizations of the National Guard.

POLO AT OHIO STATE UNIVERSITY

BY LIEUTENANT JOHN P. ECKERT, F.A.

POLO at Ohio State University, as at most other colleges where the game is played, owes its existence to the mounted unit of the R. O. T. C. The Federal government maintains here a stable containing ninety horses, primarily used for military equitation and field artillery drills. Recognizing that use might be made of these animals for polo without interference with other uses, the military authorities in 1925 authorized Captain Lewis Hershey to organize polo.

By the following year the sport was under way with a squad of about a dozen players. Their enthusiasm compensated for lack of facilities. Practice was held on the artillery drill field, a rough, weedgrown stretch of ground, both too short and too narrow for match polo. A deep ditch ran diagonally across the middle of the field, weeds grew waist high behind the goal posts, and whenever the river rose the field was under water. The university contributed side boards for this field, but no anchors to keep them from floating down the river with high tide.

In 1927 the squad had improved enough to warrant scheduling two outside games. No visiting team could be prevailed upon to risk its life on the Ohio field, so these games had to be played away from home. The squad was rewarded by victory in both contests. One game was at Somerset, Ohio. Lacking facilities and funds for shipping horses, the players rode their mounts fifty miles to Somerset, camped out with them, played the match and then made the two-day hike back to Columbus with Somerset's scalp in their belts. Since those days Somerset has greatly improved.

Captain Hershey's tour of duty was completed in the Spring of 1927. Upon his relief I took over the duties of coach. Continuing the work he had begun, we began a campaign for improvements. At first but little headway was made, but a memorable game was played against Somerset in Zanesville on Thanksgiving Day, before a crowd of 5,000 persons.

In December, 1927, polo received a great impetus in the

THE FIELD ARTILLERY JOURNAL

acquisition of forty new horses to the R. O. T. C. stables, more than doubling the number available for polo. Major Alexander Sullivan, Senior Artillery Instructor, went to Kentucky where the horses were being purchased, and supervised the selection of the remounts for Ohio. The splendid performance of these animals, both for military uses and for polo testify to the sound judgment used in their selection.

Ill fortune seemed to ride hard upon the heels of good luck, for after patiently training the new horses all during that winter, the entire stables became infected with shipping fever, and all polo playing had to be suspended during the Spring quarter of 1928.

It was a hard blow, but the poloists did not despair. They went to Culvert Military Academy to play two indoor games, the first intercollegiate contests of their experience. The remainder of the idle season was employed in erecting several necessary mechanical devices. Mr. Robert H. Hassler, O. S. U. alumnus of '92, a great polo enthusiast, contributed \$500.00 which was expended for materials for a practice cage and wooden horse, and a horse training pen. To make the funds reach, the students did most of the actual construction. Meanwhile the polo club was officially approved as a campus activity, and polo itself was accepted as an intramural sport, thereby established the first official liaison with the athletic department.

The advantages of intramural recognition were soon felt. The playing field was enlarged to regulation size, ploughed, levelled, and sown. Mr. Hodges, one of the players, devoted his entire summer vacation to this work.

With the coming of the Fall quarter, the ponies returned to health, and polo began to flourish. The club expanded to a membership of over seventy. Six teams were organized, an intramural tournament was held, and three match games were played with the Hebron Polo Club.

During the Spring quarter now closing polo has come into its own. Success was presaged by the turning out of the largest squad of underclassmen in its history. Most of them have served their apprenticeship on the famous wooden horse, and most of

POLO AT OHIO STATE UNIVERSITY

them played in several weeks tournament for the Hassler Trophy. Many green horses likewise graduated to match play. Much needed equipment was supplied by the intramural department, and Mr. Robert Hassler again proved his interest in the game at his alma mater by a generous donation. The University financed a trip to Detroit for two match games against Michigan State College in indoor polo. Another trip was made to Culver, and mallets were crossed with our old friends from Hebron and Somerset, with Troop B. O. N. G., from Cincinnati, and with the newly organized Columbus Polo Club. The greatest achievement was a victory over the team from the University of Chicago, the first "Big Ten" polo game. Because of these successes, polo has been welcomed to a place among the other official intercollegiate sports at Ohio State University, and is entering upon a new era.

To give you a complete picture of polo at O. S. U., let us follow the history of a varsity player. Our beginner is usually a freshman who has ridden horseback before coming to the University, or a sophomore in the artillery unit who has learned about horses during his military training. The candidate first enrolls in the Polo Club, an organization with nominal dues, to which all players are eligible. He is rated as Class "C" and assigned to one of the four beginner teams. These teams wear blue, yellow, white or purple colors, and have football headgears instead of polo caps. They are permitted to use only snaffle or mild bits, and wear no spurs. Before scrimmaging, however, our beginner must first be credited with fifteen days' practice on the wooden horse, to accustom him to the use of the mallet. He is assigned a slow steady horse, and instructed in the special exercises for training and controlling the horse. After fifteen days credit on the wooden horse, and about the same number of days of riding, he begins to practice with stick and ball from his pony's back. After some days of this, he is put in what is called a "slow scrimmage." When our player is able to handle himself and his horse with safety he is permitted to play at speed, and his game begins to improve. In the meanwhile, he watches the horse

THE FIELD ARTILLERY JOURNAL

assignment chart, and whenever an opportunity presents itself, discards his old mount for a better one.

It might be interesting at this point to explain about the horses. Whenever a player joins the squad, he is assigned a horse, which remains his own until he give it up voluntarily for another. No one else is permitted to ride his horse for polo except for match games, when all horses are temporarily pooled. Whenever a horse is permanently released, its name is posted on the bulletin board at the stables. Every player who wants the horse writes his name on the notice. Naturally, whenever a popular pony is posted, there is a rush of applications. After three days the pony is assigned to the senior player whose name appears on the application. This player in turn must release his old pony, which is in turn posted for reassignment. By this system the best horses are retained by the best players, as they should be, but the new players are steadily improving themselves in mounts as time passes, and the poorest, or slowest horses are discarded to less experienced players.

Now let us return to our player. In his second quarter of polo, if he has reported regularly, he should be ready for promotion to one of the Class "B" teams. These teams wear regular polo helmets or caps, green or orange, ride with pelham bits and may use whips and blunt spurs. The horses are of a better type than those in the Class "C" league, and a much faster game of polo results. How long our player must remain in class "B" depends entirely upon himself. Some may never get out. If our player is reasonably responsive and attentive, he will remain in Class "B" only one or two quarters. He then moves up to Class "A", which is the "varsity squad", consisting of two teams, the Scarlets and the Grays. Up there we find the best players and the best horses, and it is from these teams that the four is picked which represents the University in match games.

Practice routine is much the same for all classes of players. Scrimmage periods are held on Monday, Tuesday, Thursday and Friday afternoons from four to six o'clock, and on Saturday mornings. Matches are usually played on Saturday afternoons. On week days as soon as possible after four o'clock the players

POLO AT OHIO STATE UNIVERSITY

report at the stables. They saddle and bridle their horses, don helmets and colored shirts, and ride to the polo field South of the stadium. The equipment, consisting of balls, mallets, pony boots, halters, and miscellaneous tack, is transported to the field by automobile.

After brief preliminary warming up, two teams are called out for a scrimmage chukker of seven and a half minutes. As soon as the period ends another pair of teams takes the field, while horses are walked around to cool and are rubbed down. Every player gets an average of two full periods of play every afternoon of play, and the first teams usually get in three or four if the players have provided themselves with two horses apiece. A pony plays only two chukkers in an afternoon, with a rest between.

The coach referees the play, riding around among the players with a megaphone. Mistakes are corrected on the spot, and occasionally play is stopped to allow a principle to be explained or a maneuver repeated.

Playing is stopped at about five-thirty o'clock, boots are removed from ponies, saddle cinches loosened, and everyone returns to the stables. Arriving there, the player ties his mount to the picket line, presents him for inspection to his team captain and then to the stable orderly. If satisfactory, the horse is watered and tied into a stall for feed. The player then washes his saddle and bit and replaces his equipment in the tack room. By the time our polo enthusiast has completed these arrangements it will be agreed that he has partaken of plenty of exercise for the day.

There are two polo tack rooms at the stables, one for the beginners and another for the Class A and B players. Every player has his individual hook for the hanging of helmet, shirt, whip, bridles, mallets, boots and martingale.

The future promises nothing but prosperity for polo at Ohio State University. There will always be a large squad of students eager to play. The stable facilities should increase with the size of the institution. A large proportion of the animals now in possession of the unit are young, with their best polo years before them. Some day the university will undoubtedly build a new large

THE FIELD ARTILLERY JOURNAL

armory, with an indoor riding hall. That day will be a great one for indoor polo.

Looking to the immediate future, we hope soon to see a *Midwest Intercollegiate Polo Association* formed between Ohio State University, The University of Chicago, Michigan State College, Culver Military Academy and possibly the Universities of Iowa, Missouri and Illinois.

For next Fall my objective is a schedule which shall include games both at home and abroad, with Chicago, Michigan State and Culver. We hope to have grass seed sown on our field and a good turf footing by October. We also plan to improve our training pen, and to erect a training target for exercising the players in making difficult shots at goal. Add to these gains a reasonable amount of new equipment, helmets, mallets, etc., and there is no reason why our schedule next Fall should not surpass the glories of the Spring of 1929.

