

**FINDING OF NO SIGNIFICANT IMPACT**  
**NORTH COVENTRY TOWNSHIP STREAMBANK STABILIZATION PROJECT**  
**SECTION 14 - EMERGENCY STREAMBANK STABILIZATION**  
**CHESTER COUNTY, PENNSYLVANIA**

**OVERVIEW**

The United States Army Corps of Engineers (Corps), Philadelphia District has evaluated the protection of a Township road in North Coventry Township, Chester County, Pennsylvania.

**PURPOSE AND NEED**

The Corps was approached by North Coventry Township concerning an erosion problem along one of their local roads. The purpose of the project is to protect River Road, a township road threatened by streambank failure. The need for the project is the undermining of the road due to streambank erosion as result of high flow events occurring on the Schuylkill River. The erosion problem at this site was noted in 2006 and has been aggravated by flooding following Hurricane Irene in August 2011 and Tropical Storm Lee in September 2011.

**COORDINATION**

The project was developed in partnership with North Coventry Township. A scoping letter soliciting input on the proposed project was sent to appropriate state and federal agencies, as well as, other potentially interested parties in April 2012.

The Draft Environmental Assessment (EA) for the project was forwarded to the U.S. Environmental Protection Agency (EPA), Region III, the U.S. Fish and Wildlife Service (FWS), the National Marine Fisheries Service (NMFS), Pennsylvania Department of Environmental Protection (PADEP), Pennsylvania Game Commission (PGC), Pennsylvania Fish and Boat Commission (PFBC), Chester County Conservation District (CCCD), and all other known interested parties.

**ENDANGERED SPECIES**

Consultation with the U.S. Fish and Wildlife Service (FWS), and the National Marine Fisheries Service (NMFS) has determined that there will be no effect on federally listed species found in the project area. Pursuant to Section 7 of the Endangered Species Act of 1973 as amended by P.L. 96-159, consultation with the FWS and NMFS has been completed for this project.

**WATER QUALITY COMPLIANCE**

The Corps has determined that this project meets the terms and conditions of Nationwide Permit #13 (Bank Stabilization) for the construction of this project and with that permit, the Pennsylvania, Section 401 State Water Quality Certificate is automatically issued. In addition, any future maintenance requirements of the project undertaken by the non-federal sponsor, North Coventry Township, would be covered by Nationwide Permit #3 (Maintenance).

**WETLANDS**

There are no wetlands found in the project area; hence, no impacts to wetlands are anticipated as a result of this project.

**COASTAL ZONE**

Based on the information gathered during the preparation of the Environmental Assessment, the project is not located in the area defined under the Coastal Zone Management Act of 1972. Therefore, the project will not need a federal consistency determination in regards to the Coastal Zone Management Program of Pennsylvania.

**CULTURAL RESOURCES**

The proposed project is of such limited nature and scope that little likelihood exists for the proposed action to impact historic properties eligible for or listed on the National Register of Historic Places. Consultation with the Pennsylvania Historic Museum Commission and the Tribes under Section 106 of the National Historic Preservation Act has been completed and no impacts to historic resources are anticipated from this project..

**RECOMMENDATION**

Because the Environmental Assessment concludes that the work described is not a major Federal action significantly affecting the human environment, I have determined that an Environmental Impact Statement is not required.



---

Michael A. Bliss, P.E.  
Lieutenant Colonel, Corps of Engineers  
District Commander

03JUL14

Date

**ENVIRONMENTAL ASSESSMENT  
NORTH COVENTRY TOWNSHIP STREAMBANK STABILIZATION  
PROJECT  
SECTION 14 - EMERGENCY STREAMBANK STABILIZATION  
CHESTER COUNTY, PENNSYLVANIA**

**PREPARED BY:  
PHILADELPHIA DISTRICT  
U.S. ARMY CORPS OF ENGINEERS  
PHILADELPHIA, PENNSYLVANIA 19107**

**July 2014**

ENVIRONMENTAL ASSESSMENT  
 NORTH COVENTRY STREAMBANK STABILIZATION PROJECT  
 SECTION 14 – EMERGENCY STREAMBANK STABILIZATION  
 CHESTER COUNTY, PENNSYLVANIA

TABLE OF CONTENTS

|      |   |    |
|------|---|----|
| 1.0  | Project Location .....  | 1  |
| 2.0  | Study Authority.....  | 2  |
| 3.0  | Purpose and Need for Action.....  | 2  |
| 4.0  | Alternatives .....  | 4  |
| 4.1  | No action.....  | 4  |
| 4.2  | Making the Existing Road One Way .....  | 4  |
| 4.3  | Relocate the Existing Road.....   | 5  |
| 4.4  | Armoring the Streambank with Rip Rap .....  | 5  |
| 4.5  | Armoring / Bioengineering Combination of the Streambank.....                        | 5  |
| 5.0  | Existing Environment .....  | 8  |
| 5.1  | Air quality .....   | 8  |
| 5.2  | Water Quality.....  | 8  |
| 5.3  | Wetlands .....  | 9  |
| 5.4  | Fisheries .....   | 9  |
| 5.5  | Wildlife Resources.....   | 9  |
| 5.6  | Threatened and Endangered Species .....   | 10 |
| 5.7  | Cultural Resources .....  | 10 |
| 5.8  | Recreation .....  | 10 |
| 5.9  | Noise .....   | 11 |
| 6.0  | Environmental Impacts .....   | 11 |
| 6.1  | Air quality .....   | 11 |
| 6.2  | Water Quality.....  | 12 |
| 6.3  | Wetlands .....  | 13 |
| 6.4  | Fisheries .....   | 13 |
| 6.5  | Wildlife Resources.....   | 13 |
| 6.6  | Threatened and Endangered Species .....   | 13 |
| 6.7  | Cultural Resources .....  | 13 |
| 6.8  | Recreation .....  | 14 |
| 6.9  | Noise .....   | 14 |
| 6.10 | Cumulative.....   | 14 |
| 7.0  | Environmental Justice.....  | 14 |
| 8.0  | Relationship of Selected Plan to Environmental Statutes and Other Requirements..... | 15 |
| 9.0  | Section 404(b)(1) Analysis .....  | 15 |

|      |  |            |
|------|--|------------|
| 10.0 | References.....  | 21         |
| 11.0 | Clean Air Act Consistency Statement.....                         | 22         |
| 12.0 | Proposed Project Conceptual Design.....                          | Appendix A |
| 13.0 | Relevant Correspondence .....                                    | Appendix B |
| 14.0 | Clean Air Assessment.....  | Appendix C |
| 15.0 | Public/Agency Comments to the draft EA and Corps Responses ..... | Appendix D |

#### LIST OF FIGURES

|           |   |   |
|-----------|---|---|
| Figure 1. | General Vicinity Map for Schuylkill River at North Coventry Township, PA..... | 1 |
| Figure 2. | Site specific location map for proposed project .....                         | 2 |
| Figure 3. | View of project area from the opposite streambank.....                        | 3 |
| Figure 4. | View of project area with the failing streambank .....                        | 3 |
| Figure 5. | Another view of project area with failing streambank and infrastructure.....  | 4 |

#### LIST OF TABLES

|          |  |    |
|----------|--|----|
| Table 1. | Alternative Analysis. ....                               | 7  |
| Table 2. | Compliance with Appropriate Environmental Statutes ..... | 15 |

## 1.0 Project Location

The project site is located on River Road along the Schuylkill River in North Coventry Township, Chester County, Pennsylvania. The project begins in the existing ditch below the State Highway 100 overpass, and extends approximately 1900' downstream towards Hanover Street (Figures 1 and 2).

The watershed of the Schuylkill River, a major tributary to the Delaware River, is located in southeastern Pennsylvania, and includes large parts of Schuylkill, Berks, Montgomery, Chester, and Philadelphia Counties. The Schuylkill River watershed is about 80 miles long and 25 miles wide, and encompasses an area of approximately 1,916 square miles (Natural Lands Trusts *et al*, 2001).

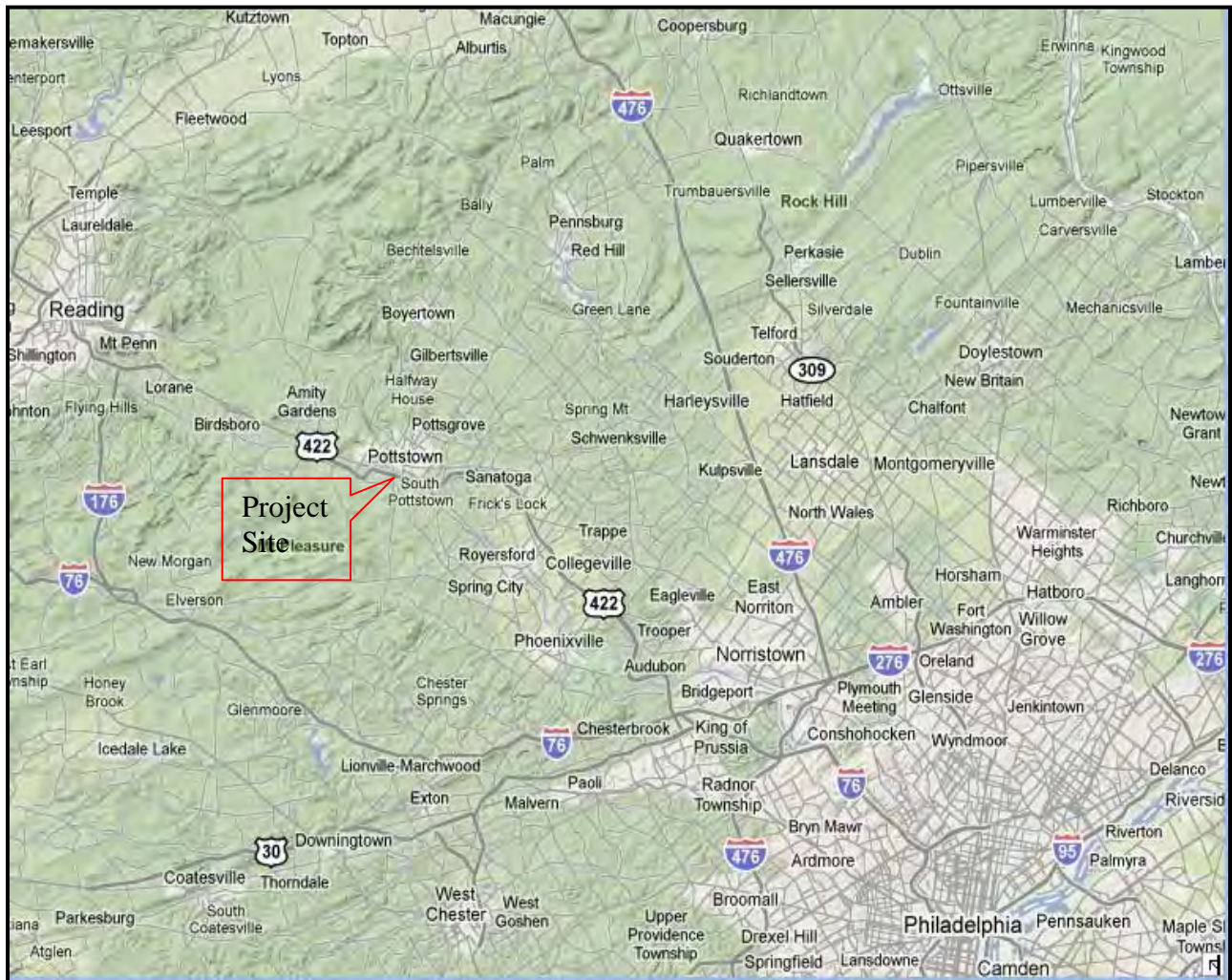

Figure 1: General Vicinity Map for Schuylkill River at North Coventry Township, PA.



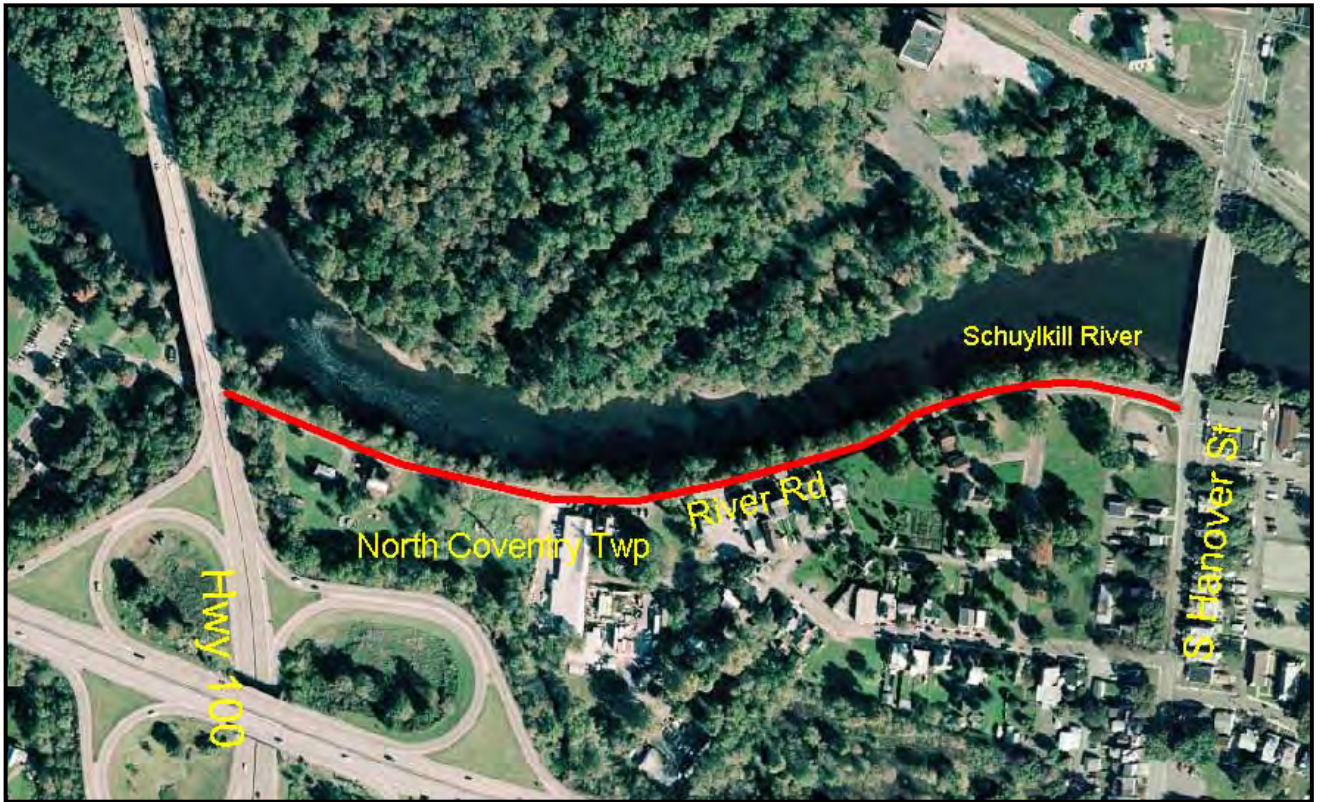

Figure 2: Location of streambank stabilization project on River Road in North Coventry Township, PA.

## 2.0 Study Authority

This investigation is conducted under the Continuing Authorities Program, Section 14 of the 1946 Flood Control Act (33 U.S.C. 701r), as amended. The purpose of the Section 14 authority is to protect public works and non-profit public facilities from streambank and shoreline erosion. Federal funding for each Section 14 project is limited to \$1,500,000 (as amended by Section 2023 of the Water Resources Development Act of 2007, P.L. 110-114).

## 3.0 Purpose and Need for Action

The U.S. Army Corps of Engineers (Corps), Philadelphia District, was approached by North Coventry Township concerning an erosion problem along one of their local township roads (Figures 3-5). The purpose of the project is to protect River Road, a township road threatened by streambank failure. The need for the project is the undermining of the road due to streambank erosion as result of high flow events occurring on the Schuylkill River. The erosion problem at this site was noted in 2006 and has been aggravated by flooding following Hurricane Irene in August 2011 and Tropical Storm Lee in September 2011.





Figure 3. View of project area from the opposite streambank (Photo - May 2014).



Figure 4. View of project area with the failing streambank (Photo – May 2014).





Figure 5. Another view of project area with failing streambank and infrastructure (Photo – May 2014).

#### **4.0 Alternatives**

##### **1. No Action.**

The “no action” alternative would not provide any protection to the existing streambank and thus, River Road. This would lead to continual bank erosion and eventually River Road would be in danger of failure. It is likely that if nothing is done at this project location, the road embankment will continue to erode and the stability of the road will be threatened in the future. The Corps will keep the “no action” alternative in the analysis pursuant to National Environmental Policy Act regulations.

##### **2. Making the Existing Road One Way**

This alternative involves the redesigning of the existing road to make River Road in this section one way. This alternative to move traffic away from the eroding streambank and provide safer passage of vehicles along River Road was initially identified in a 2004 planning study by the Township. That study proposed either keeping the 33 feet right of way as two-10-foot wide traffic lanes with a 5 feet buffer and 8 feet wide trail or eliminating one lane of vehicular traffic and substituting a wider buffer and trail area in the right of way. This would have an impact on the local traffic patterns, as well as the residents of River Road. This alternative would provide some years of service until the road was compromised,

but would still leave the area vulnerable to future streambank erosion and eventual road failure. The addition, of a pedestrian trail along the road would be an enhancement, but there are no current links that would access the trail segment, so it would be a stand-alone 1900 foot trail section. The Schuylkill River Trail (SRT) is already located across the river and provides the public ample access to a long distance trail. In addition, without addressing the streambank erosion now, this alternative would just delay the failure of the road.

### 3. Relocate the Existing Road

This alternative would involve purchasing up to 10 residential properties (median housing value: \$151, 800), 2 business properties, 18 other parcels, and relocating local utilities. Based on this information, the cost for this alternative would likely exceed \$2 million, which would be cost prohibitive to the non-federal sponsor. In addition, this alternative would disrupt the local traffic patterns for an extended period during construction of a re-aligned road. Furthermore, without addressing the streambank erosion now, this alternative would just delay the failure of the road; and without protection, the stream will continue to erode the streambank and eventually reach any nearby relocated road.

### 4. Armoring the Streambank using Rip Rap

This alternative involves the use of substantial amounts of rip rap and / or gabion baskets to cover approximately 8 feet of the streambank. This alternative would provide for immediate protection of the streambank of River Road, but the cost and environmental impact would be significant. However, the amount of rock needed to construct this alternative would be significant (approx. 5000 cubic yards). Gabion baskets require frequent maintenance, which would add to the cost of this alternative. In addition, rip rap or gabion baskets would provide very little habitat for fish and wildlife in the Schuylkill River that would utilize the streambank. Furthermore, the public would probably consider a 1900 foot segment of rip rap to be much less aesthetically pleasing than a planted river bank.

### 5. Armoring / Bioengineering Combination on the Streambank

This alternative consists of stabilizing the west streambank of the Schuylkill River along River Road with a combination of riprap and vegetative cover. The proposed project recommends the use of Longitudinal Peak Stone Toe Protection (LPSTP). The project begins in the existing ditch below the State Highway 100 overpass, and extends approximately 1900 feet downstream towards Hanover Street. The first 960 feet of the project is referenced as Range 1, and then there is a break (with no construction) for approximately 800 feet. Then the final 200 feet of the project is referenced as Range 2 (Figures 4-6). The LPSTP is a continuous stone dike that is comprised of well sorted stone that is placed at the toe of the eroding bank, or slightly streamward of this area. The cross-section of the LPSTP is triangular in shape, and does not follow the toe exactly, but can be placed in a way that a “smooth” alignment can be created through bend locations. The amount of stone to be used in this design is based on 2-3 ton per linear foot, resulting in approximately 5 feet of toe protection. The LPSTP keys, which tie the LPSTP into the existing bank, must be keyed into the bank at both the upstream and downstream ends at 20 to 30° to the flow of the river, and at 150 foot intervals along the entire length of the protected area. These keys will be placed a minimum of 15 feet into the existing bank to prevent river migration from flanking the key and the LPSTP.

Range One has a minimum bottom width of 10 feet, and a minimum height of 5 feet. Range Two has a

minimum bottom width of 6 feet, and a minimum height of 3 feet. The side slopes of both ranges should be 1 horizontal to 1.5 vertical. Range One will have approximately five keys tied back into the existing bank, and Range Two will have one. These key totals do not include the tie in keys at the upstream and downstream ends of the range.

Bendway weirs, structures built into the river that are perpendicular to the flow, will be constructed to redirect the erosive power of the river away from the protected bank. In addition, bendway weirs will be used to control the thalweg (the section of the river that is the deepest and has the highest velocities) and help realign the thalweg with the downstream bridge. The bendway weirs will only be placed in Range 1 and will be spaced between 130 -140 feet apart. They will protrude into the river approximately 30 feet from the streamward toe of the LPSTP. They will have a crest width of 10 feet and will be constructed out of well graded R7 riprap.

For both ranges there should be minimum excavation along the toe prior to the placement of stone. The bank side of the riprap will be backfilled with a gravel-cobble-sand mix to a certain height and then backfilled with soil. Prior to backfilling with the gravel-cobble-sand mix and soil, there will be an assortment of willow and dogwood planting poles placed along the back slope of the LPSTP and along the existing bank. The soil will then be backfilled to cover the poles, leaving the recommended length of the poles exposed. Sycamore, red maple and other native species of trees and shrubs will be planted in this soil after backfilling is completed. All areas disturbed during the construction process will be hydroseeded using a bonded fiber matrix.

The proposed construction would be completed in the dry using a cofferdam constructed of poles and fabric (e.g., portadam) during the low flow period of June through November. Since water levels in the Schuylkill River can approach up to 10 foot depths the cofferdam type will be further investigated as the project designs are finalized. In addition, a turbidity curtain would be used to supplement the cofferdam, as needed. The total amount of stone for this alternative would be approximately 1800 cubic yards (cu yds) and the total amount of fill would be approximately 2600 cu yds. This amount of stone is substantially less than the previously discussed rip rap alternative. This is our proposed selected plan (see Appendix A for conceptual plans). Also, Table 1 summarizes the alternatives considered for this project.

| <b>Table 1. Alternative Analysis</b> |  |   |  |  |  |
|--------------------------------------|--|---|--|--|--|
|                                      | <b>Alternative 1</b>   | <b>Alternative 2</b>  | <b>Alternative 3</b>   | <b>Alternative 4</b>   | <b>Alternative 5</b>   |
|                                      | <b>No Action</b>   | <b>Making the Existing Road One Way</b>   | <b>Relocate the Existing Road</b>  | <b>Armoring the Streambank using Rip Rap</b>   | <b>Armoring / Bioengineering Combination on the Streambank</b>   |
| <b>Benefits</b>                      | <ul style="list-style-type: none"> <li>• None</li> </ul>   | <ul style="list-style-type: none"> <li>• No impact to Schuylkill River</li> <li>• Public trail segment</li> <li>• Low cost</li> </ul>   | <ul style="list-style-type: none"> <li>• No impact to Schuylkill River</li> <li>• New road would be further away from the eroding bank and increase the longevity of that road.</li> </ul> | <ul style="list-style-type: none"> <li>• Protect the streambank and River Road.</li> </ul>   | <ul style="list-style-type: none"> <li>• Protect the streambank and River Road.</li> <li>• Significantly less fill stone needed, then Alternative #4.</li> <li>• Native plants used in bioengineering, improve habitat in the riparian area.</li> <li>• This is the preferred plan.</li> </ul> |
| <b>Potential issues</b>              | <ul style="list-style-type: none"> <li>• Streambank continues to erode and undermine.</li> <li>• Eventual road failure</li> <li>• Public safety issue</li> </ul> | <ul style="list-style-type: none"> <li>• Real estate easements needed from local landowners</li> <li>• Does not stop erosion of the streambank and will lead to eventual road failure.</li> <li>• Public parking for trail may impact local residents.</li> </ul> | <ul style="list-style-type: none"> <li>• Real estate easements needed from local landowners.</li> <li>• Real estate costs, must purchase property</li> <li>• High cost</li> </ul>          | <ul style="list-style-type: none"> <li>• Lots of stone needed, large impact on the Schuylkill River.</li> <li>• High cost</li> </ul> | <ul style="list-style-type: none"> <li>• Cofferdam withstanding the flows of Schuylkill River during construction.</li> </ul>  |
| <b>Maintenance costs</b>             | No cost  | Medium  | Medium   | Medium   | Medium   |
| <b>Wetland impacts</b>               | 0  | 0   | 0  | 0  | 0  |
| <b>Construction Cost</b>             | No cost  | Low   | High   | High   | Medium   |



## **5.0 Existing Environment**

### **5.1 Air Quality**

Ambient air quality is monitored by the Pennsylvania Department of Natural Resources and Environmental Control's (PADEP) Division of Air and Waste Management and is compared to the National Ambient Air Quality Standards (NAAQS) throughout the state, pursuant to the Clean Air Act of 1970. Six principal "criteria" pollutants are part of oxides of nitrogen (NO<sub>x</sub>), particulate matter (PM<sub>10</sub> and PM<sub>2.5</sub>), and lead (Pb). Stationary sources include power plants that burn fossil fuels, factories, boilers, furnaces, manufacturing plants, gasoline dispensing facilities, and other industrial facilities. Mobile sources include vehicles such as cars, trucks, boats, and aircraft.

Chester County, Pennsylvania within which the Federal Action will take place is classified as moderate nonattainment for ozone (oxides of nitrogen [NO<sub>x</sub>] and volatile organic compounds [VOCs]). For ozone Chester County is classified within the Philadelphia-Wilmington-Atlantic City Nonattainment Area (PA-NJ-DE-MD). Chester County, PA is also classified as nonattainment for PM<sub>2.5</sub>. For PM<sub>2.5</sub>, Chester County, PA is classified within the Philadelphia-Wilmington Nonattainment Area (PA-NJ-DE).

### **5.2 Water Quality**

Few river basins have had a longer or stronger connection to socioeconomic, cultural, and industrial development in the United States than the Schuylkill River Basin. This is because the land and water of the Schuylkill Basin have provided many of the resources needed over the last 350 years by colonial, industrial, and even modern Philadelphia, which lies at the downstream end of the basin (Stroud Water Research Center, 2012).

The Schuylkill River basin today bears little resemblance to the pristine woods found by the first Europeans. However, it is still an invaluable natural resource for the 3 million people that live in the watershed as well as the additional 3 million people from neighboring watersheds that together represent the Philadelphia metropolitan area. For example, forests have regrown to cover about 41% of the basin, and now represent important areas for recreation, wildlife, and potentially silviculture (forest harvesting). Agriculture still occupies 40% of the acreage while developed lands represent about 13%. Finally, surface and groundwater resources in the Basin continues to provide drinking water for more than 3 million people (Stroud Water Research Center, 2012).

The study area is in a highly developed suburban section of Chester County, PA. The Schuylkill River is classified as an urban stream on the EPA and the State list of impaired streams. There are excessive levels of nutrients, suspended solids, pathogens and metals in the stream water. It is polluted by both point and non-point sources.

The use of benthic (i.e., bottom-dwelling) macroinvertebrates such as insects, worms, and crayfish that live in the River and its tributaries to assess current water and habitat quality is a common way to assess water quality (Hellowell 1986). Based on the report for the Southwest Schuylkill Basin with the closest water quality sampling site at Pigeon Creek at Old Schuylkill Road (Site #127), the Macroinvertebrate Aggregated Index for Streams (MAIS) was determined to be 9.2 and rated as fair (Stroud Water Research Center, 2012).

### 5.3 Wetlands

The project is located in the riparian area adjacent to the Schuylkill River. There are no wetlands within the project area.

### 5.4 Fisheries

The Schuylkill River is classified by PADEP as migratory fish waters and the river has many fish passage facilities located on it. The Fairmount Dam, Flatrock Dam, Black Rock, and Norristown Dam all have fish ladders constructed on them to allow fish passage. The migratory fish species found in the Schuylkill River and likely to use the fish ladders include American shad (*Alosa sapidissima*), blueback herring (*Alosa aestivalis*), alewife (*Alosa pseudoharengus*), striped bass (*Morone saxatilis*), white perch (*Morone americana*), American eel (*Anguilla rostrata*), Gizzard shad (*Dorosoma cepedianum*), and hickory shad (*Alosa mediocris*). The migratory period for most of these species is dependent on water temperature, but typically occurs from April – June.

In 2009, the Pennsylvania Fish and Boat Commission (PFBC) conducted an electrofishing survey of the Schuylkill River in Montgomery County from the area directly below Plymouth Dam downstream to the Matsonford Bridge in Conshohocken. The main purpose of the survey was to document the presence or absence of American shad adults.

In the survey, 2 male American shad (16.5 inches long and 19 inches long) were captured. No other American shad were observed. Their discovery was the first time that American shad adults had been known to be present in the Conshohocken area since about 1820 when Fairmount Dam was built.

Other fish species identified in the 2009 survey included smallmouth bass (*Micropterus dolomieu*), walleye (*Sander vitreus*), channel catfish (*Ictalurus punctatus*), and flathead catfish (*Pylodictis olivaris*). Sixty smallmouth bass were captured and ranged in lengths from 5 to 19.5 inches. Numerous other smallmouth bass over 15 inches long were observed, but could not be captured. Fifteen channel catfish were captured and ranged in length from 18 to 24 inches. A similar number were observed, but not captured. One flathead catfish was captured, although two others (one over 30 inches) were observed escaping the electrical field. Three walleye were captured and ranged in length from 11 to 24.5 inches. Other fish species captured or observed included: white sucker (*Catostomus commersonii*), quillback (*Carpionodes cyprinus*), gizzard shad, satinfin shiner (*Cyprinella analostana*), and American eel (PFBC, 2009).

In addition, coordination with the National Marine Fisheries Service (NMFS) determined that there was no essential fish habitat in the proposed project area.

### 5.5 Wildlife Resources

Due to the extensive development in the Schuylkill River watershed, there are limited wildlife resources in the project vicinity. In addition, the absence of a well-defined riparian buffer at the project location further limits wildlife populations in the project area.

The following species of bird are likely to be found within the project area: turkey vulture (*Cathartes aura*), red-tailed hawk (*Buteo jamaicensis*), American crow (*Corvus brachyrhynchos*), robin (*Turdus*

*migratorius*), northern cardinal (*Richmondna cardinalis*), blue jay (*Cyanocitta cristata*), and various species of sparrows.

Some examples of indigenous waterfowl which may frequent the project area include: Canada goose (*Branta canadensis*) and mallard (*Anas platyrhynchos*). Other bird species likely to inhabit the area include: kingfisher (*Megaceryle alcyon*), red-winged blackbird (*Agelaius phoeniceus*), American crow (*Corvus brachyrhynchos*), robin (*Turdus migratorius*), northern cardinal (*Richmondna cardinalis*), blue jay (*Cyanocitta cristata*), catbird (*Dumetella carolinensis*), and various species of sparrows. Additional bird species observed along the Schuylkill River include: great blue heron (*Ardea herodias*) and double-crested cormorant (*Phalacrocorax auritus*).

Although reptiles and amphibians were not actually surveyed within the project area, the following species are typically found inhabiting riverine zones: snapping turtle (*Chelydra serpentina*), water snake (*Natrix sipedon*), and American bullfrog (*Rana catesbeiana*). The eastern newt (*Notophthalmus viridescens*) and American toad (*Bufo americanus*) are additional representative species likely to reside in this area.

Mammals which are indicative of riparian zones and may occur in and around the Schuylkill River project area are: muskrat (*Ondatra zibethicus*), raccoon (*Procyon lotor*), opossum (*Didelphis virginiana*), woodchuck (*Marmota monax*), chipmunk (*Tamias striata*), gray squirrel (*Scirus carolinensis*), eastern cottontail (*Sylvilagus floridanus*), and little brown bat (*Myotis lucifugus*).

## **5.6 Threatened and Endangered Species**

According to a Pennsylvania National Diversity Inventory (PNDI) search completed in May 2012, there was the potential of two species of special concern: redbelly turtle (*Pseudemys rubriventris*) and Pizzini's cave amphipod (*Stygobromus pizzinii*) to be in the project vicinity. A letter dated May 10, 2012 from the PA Fish and Boat Commission (PFBC) confirmed that redbelly turtle was known in the project vicinity. No federal listed species were identified in the project area.

## **5.7 Cultural Resources**

The proposed project's Area of Potential Effect (APE) is bounded to the south by River road, to the north by the Schuylkill River, to the west by the existing drainage ditch under the SH 100 Bridge, and to the east by the limits of proposed fill near the intersection of River Road and York Street, North Coventry Township, Chester County. Background and CRGIS database research show no historic properties recorded in the project APE. There are historic properties within a one mile radius of the APE, which include historic districts (Pottstown Industrial Historic District, Old Pottstown Historic District), historic structures (Reading Railroad Station, Pottstown Roller Mill), historic archaeological sites (36CH0828 and 36MG0277) and Native American Archaeological sites (36MG0354, 36MG0353, 36MG0395, 36CH0892, and 36CH0895 and 36CH0894). None of these sites will be affected by the proposed project.

## **5.8 Recreation**

Recreational opportunities in the Schuylkill River area of North Coventry Township typically focus on the Schuylkill River Trail (SRT), which is located across the river from our proposed project. The Schuylkill River trail is an approximately 130 mile long trail from Philadelphia to Auburn, PA.

The river is also an important source of recreational fish and boating for Southeastern Pennsylvania residents.

## **5.9 Noise**

Sensitivity to ambient noise levels differs among land use types. For example, residential areas, libraries, schools, churches, and hospitals are generally more sensitive to noise than commercial and industrial land uses. The majority of land use along the river in the vicinity of the project is residential and light commercial, which generally have a higher sensitivity to ambient noise levels.

The project location is adjacent to State Route 100, which is a high speed local road artery for the region. In addition, River Road acts a feeder road for locals to get to and from the Coventry Mall. Hence, the existing noise level from traffic in the project area is moderate.

## **6.0 Environmental Impacts**

### **6.1 Air quality**

Air quality within the project area is reflective of a developed suburb of Chester County, Pennsylvania within which the Federal Action will take place and is classified as moderate nonattainment for ozone (oxides of nitrogen [NO<sub>x</sub>] and volatile organic compounds [VOCs]). Chester County, PA is also classified as nonattainment for particulate matter (PM 2.5).

Construction of the streambank stabilization project would cause temporary reduction of local ambient air quality due to fugitive dust and emissions generated by construction equipment. These temporary reductions in air quality would not have a significant impact on the long term air quality of the surrounding area.

### **General Conformity Review and Emission Inventory**

#### **North Coventry**

The 1990 Clean Air Act Amendments include the provision of Federal Conformity, which is a regulation that ensures that Federal Actions conform to a nonattainment area's State Implementation Plan (SIP) thus not adversely impacting the area's progress toward attaining the National Ambient Air Quality Standards (NAAQS). In the case of the North Coventry project, the Federal Action is to protect an eroding stream bank. The U.S. Army Corps of Engineers, Philadelphia District would be responsible for construction. Chester County, Pennsylvania within which the Federal Action will take place is classified as moderate nonattainment for ozone (oxides of nitrogen [NO<sub>x</sub>] and volatile organic compounds [VOCs]). The North Coventry project site is within the Philadelphia-Wilmington-Trenton Nonattainment Area (PA-NJ-DE-MD).

There are two types of Federal Conformity: Transportation Conformity and General Conformity (GC). Transportation Conformity does not apply to this project because the project is not funded by the Federal Highway Administration and it does not impact the on-road transportation system. GC however is applicable. Therefore, the total direct and indirect emissions associated with the North Coventry project must be compared to the GC trigger levels presented below.

#### **General Conformity**



| Pollutant         | Trigger Levels<br>(tons per year) |
|-------------------|-----------------------------------|
| NO <sub>x</sub>   | 100                               |
| VOCs              | 50                                |
| PM <sub>2.5</sub> | 100                               |

To conduct a general conformity review and emission inventory for the North Coventry project, a list of equipment necessary for construction was identified. Table 1 (Appendix C) lists these pieces of equipment along with the number of engines, engine size (hp), and duration of operation. A Load Factor (LF) was also selected for each engine, which represents the average percentage of rated horsepower used during a source's operational profile. Load factors were taken from other General Conformity Reviews and Emission Inventories.

Table 1 (see Appendix C) shows the estimated hp-hr required for each equipment/engine category. Hp-hr was calculated using the following equation:

$$\text{hp-hr} = \# \text{ of engines} * \text{hp} * \text{LF} * \text{hrs/day} * \text{days of operation}$$

The second calculation is to derive the total amount of emissions generated from each equipment/engine category by multiplying the power demand (hp-hr) by an emission factor (g/hp-hr). The following equations were used:

$$\text{emissions (g)} = \text{power demand (hp-hr)} * \text{emission factor (g/hp-hr)}$$

$$\text{emissions (tons)} = \text{emissions (g)} * (1 \text{ ton}/907200 \text{ g})$$

Tables 2, 3, and 4 (see Appendix C) presents the emission factors and emission estimates for NO<sub>x</sub>, VOCs, and PM<sub>2.5</sub> respectively. The tables present the emissions from each individual equipment/engine category and the combined total. Table 5 provides emissions associated with worker's personal vehicles and the total emissions for the project.

The total estimated emissions that would result from construction of the streambank stabilization project is 1.8 tons of NO<sub>x</sub>, 0.4 tons of VOCs, and 0.41 PM<sub>2.5</sub>. Construction of the project will be completed in 4 months. These emissions are below the General Conformity trigger levels of 100 tons of NO<sub>x</sub> and PM<sub>2.5</sub>; and 50 tons of VOCs per year. General Conformity under the Clean Air Act, Section 176 has been evaluated for the project according to the requirements of 40 CFR 93, Subpart B. The requirements of this rule are not applicable to this project because the total direct and indirect emissions from the project are below the conformity threshold values established at 40 CFR 93.153 (b) for ozone (NO<sub>x</sub> and HC) in a Moderate Nonattainment Area (100 tons and 50 tons of each pollutant per year) and 100 tons for PM<sub>2.5</sub>. The project is not considered regionally significant under 40 CFR 93.153 (i).

## 6.2 Water Quality

Implementation of this project will have temporary impacts to water quality. All necessary best management practices will be used during construction. A cofferdam will be used to complete the streambank stabilization in the dry. This will greatly minimize the amount of turbidity in the river

during construction of this project. The proposed project will not likely have any long-term adverse impacts on the water quality of the Schuylkill River. By stabilizing the bank and preventing further erosion in the section of the river, the long-term impacts will be minimal and possibly even positive in nature. A sediment and erosion control plan using best management practices will be used during construction of this project to minimize impacts on the river.

### **6.3 Wetlands**

There are no wetlands in the project area, so no wetlands will be impacted as a result of this project.

### **6.4 Fisheries**

Consultation with the NMFS concluded no essential fish habitat under the Magnuson-Stevens Fishery Conservation and Management Act or trust resources in the project area (see Appendices B and D) under their jurisdiction. In addition, as per their comments under the Fish and Wildlife Coordination Act, to avoid potential impacts to American shad, we will avoid all in water construction work from April 1 – June 30 to the extent possible.

There will be temporary minor impacts (increased turbidity) to resident fish populations in the Schuylkill River during the construction of this project. However, the project will provide for the long term stabilization of the streambank in that reach of the stream and may result in long-term benefits to the riparian corridor.

### **6.5 Wildlife**

No long-term impacts to the wildlife resources in Schuylkill River area are anticipated as a result of this project. There will be noise and general disturbances in the stream area as a result of construction activities, but these will be temporary in nature and should not have a long term negative effect on wildlife in the area. With the planting of native vegetation along the top of the newly protected streambank, there may be a long-term positive impact to the riparian corridor along the river.

### **6.6 Threatened and Endangered Species**

Consultation under Section 7 of the Endangered Species Act is completed for this project. A letter from the U.S. Fish and Wildlife Service from January 2013 states that the project will have an insignificant or discountable effect on federally listed species (Appendix B). In addition, in a letter from April 2012, the NMFS stated that there were no federally listed species found in project area under their jurisdiction (Appendices B and D).

In addition, a letter from the Pennsylvania Fish and Boat Commission (PFBC) indicated that the proposed project activities would not impact the state-listed (threatened) eastern redbelly turtle (identified in the PNDI for the project). Hence, we do not anticipate any impacts to federally or state-listed species as a result of this project.

### **6.7 Cultural Resources**

Although there are recorded sites in the vicinity of the project area, none have been recorded in the project APE, and none will be impacted by the proposed project. Although the APE is located in an area considered high probability for the presence of Native American archaeological sites, the proposed

project has little likelihood of impacting a site since the alternatives discussed will add fill to the area and not remove intact soils. If unrecorded cultural resources are within the APE, the proposed project will serve to bury and protect any resources from further erosion. Consultation with the Pennsylvania Historic Museum Commission and the Tribes under Section 106 of the National Historic Preservation Act is ongoing for this project and will be completed prior to project construction.

## **6.8 Recreation**

As noted in Section 5.8, the Schuylkill River valley has a wide variety of recreational resources. One potential impact of the proposed project on local recreation would be to fishing in the immediate project area. During construction, the increase in the turbidity of the river would affect local angling in the immediate area around and downstream of the project site. This impact would be temporary and angling opportunities would return to normal shortly after construction is completed.

As noted in Section 5.8, the SRT is located across the river from the proposed project. Besides, temporary aesthetic issues during construction of the proposed streambank protection, there should be no impact on the recreation on the SRT.

## **6.9 Noise**

Temporary impacts due to increased construction noise may be experienced by nearby homeowners during the project construction. Construction activities will require the use of heavy construction equipment including but not limited to excavators, loaders, and dump trucks. An increase in road traffic and possibly traffic interruption can also be anticipated. Construction time is temporary in nature and would be approximately four months. Under normal circumstances, noise will only be generated Monday through Friday during normal working hours. There should be no long-term adverse noise impacts associated with our proposed completed project.

## **6.10 Cumulative**

We do not anticipate that protecting approximately 1900' of streambank should have any long-term negative cumulative effects on the Schuylkill River. In fact, with our proposed use of bioengineering and native plants, the riparian area of that section of the Schuylkill River should be improved for the local wildlife.

In addition, as we move forward with the planning process of this project, we will consider ways to reduce the impact of our selected alternative. This will include consideration of alternative construction techniques, best management practices during project construction, and planning for storm events on the construction site.

## **7.0 Environmental Justice**

All of the alternatives evaluated for this project, including the preferred plan, are expected to comply with Executive Order 12989-Environmental Justice in Minority Populations and Low-Income Populations, dated February 11, 1994. The selected plan is not located in close proximity to a minority or low-income community, and no impacts are expected to occur to any minority or low-income communities in the area.

## 8.0 Relationship of Selected Plan to Environmental Requirements, Protection Statutes, and Other Requirements

Compliance with environmental quality protection statutes and other environmental review requirements is ongoing. Table 2 provides a listing of compliance with environmental statutes. The Corps has determined that this project meets the terms and conditions of Nationwide Permit #13 (Bank Stabilization) for the construction of this project and with that permit, the Pennsylvania, Section 401 State Water Quality Certificate is automatically issued. In addition, any future maintenance requirements of the project undertaken by the non-federal sponsor, North Coventry Township, will be covered by Nationwide Permit #3 (Maintenance). A Section 404(b)(1) analysis of the Clean Water Act, as amended (Public Law 92-500), was completed for this project based and included in this document.

TABLE 2. Compliance with Appropriate Environmental Quality Protection Statutes and other Environmental Review Requirements.

| STATUTE                            | COMPLIANCE STATUS |
|------------------------------------|-------------------|
| Clean Water Act                    | Full              |
| Coastal Zone Management Act        | N/A               |
| Endangered Species Act             | Full              |
| Fish and Wildlife Coordination Act | Full              |
| National Historic Preservation Act | Full              |
| National Environmental Policy Act  | Full              |
| Clean Air Act                      | Full              |

**NOTE:**

Full Compliance: Having met all requirements of the statute, E.O., or other environmental requirements for the current stage of planning.

Partial Compliance: Some requirements of the statute, E.O., or other policy and related regulations remain to be met.

\*All applicable laws and regulations will be fully complied with upon completion of the environmental review, obtaining state water quality certification, coastal zone consistency determination, and concurrence with our determination on cultural resources.

Noncompliance: None of the requirements of the statute, E.O., or other policy and related regulations remain to be met.

## 9.0 Section 404(b)(1) Analysis

A review of the impacts associated with discharges to waters of the United States for the North Coventry Streambank Protection Project in Chester County, PA is required by Section 404(b)(1) of the Clean Water Act, as amended (Public Law 92-500).

### I. PROJECT DESCRIPTION

A. Location. The project area is located in North Coventry Township, Chester County, PA.

B. General Description. The project site is located along the Schuylkill River in Chester County, Pennsylvania. The project begins in the existing ditch below the State Highway 100 overpass, and extends approximately 1900' downstream towards Hanover Street.

C. Purpose. The goal of this project is to restore bank stability and to protect River Road from eventual



failure. The proposed streambank protection project consists of stabilizing the west bank of the Schuylkill River along River Road with a combination of riprap and vegetative cover. The proposed project recommends the use of Longitudinal Peak Stone Toe Protection and bioengineering with native plants.

D. General Description of Dredged or Fill Material.

1. General Characteristics of Material: rock and soil.
2. Quantity of Discharge: The estimated quantity of fill is 1800 cu yds of rock and 2600 cu yds of soil.
3. Source of Material: imported rock and soil to the project site.

E. Description of Discharge Sites.

2. Location: along the existing streambank of the Schuylkill River.
3. Size (acres): The project site is approximately 1900 linear ft. The amount of stone will be 1800 cu yds and soil will be 2600 cu yds.
3. Type of Sites: Floodplain/Riparian Corridor
4. Type of Habitat: Floodplain/Riparian Corridor
5. Timing and Duration of Discharge: A four month construction period.

F. Description of Discharge Method. Placing stone and then filling behind it along the streambank.

II. FACTUAL DETERMINATIONS

A. Physical Substrate Determinations.

1. Substrate Elevation and Slope: varies
2. Sediment Type: sand/soil/clay
3. Fill Material Movement: Significant, material will be placed in flowing water.
4. Physical Effects on Benthos: Temporary, major effect on flow and patterns during construction. Any local benthos will be buried when the rock is placed at the toe of the streambank. The streambank habitat should be re-populated with benthos after project construction, likely within 1-year.
5. Actions taken to Minimize Impacts: Best management practices will be used during construction, including a cofferdam which will allow the project to be constructed in the dry to keep the turbidity and sediment moving downstream to a minimum. In addition, any new created streambank will be seeded or planted as

soon as possible.

B. Water Circulation, Fluctuation and Salinity Determinations.

1. Water:

- a. Salinity – No effect
- b. Water Chemistry – Temporary, minor effect.
- c. Clarity – Temporary, major effect
- d. Color - No effect
- e. Odor – No effect.
- f. Taste - No effect.
- g. Dissolved Gas Levels – Temporary, minor effect
- h. Nutrients – Temporary, major effect
- I. Eutrophication - No effect.
- j. Temperature- No effect.

2. Current Patterns and Circulation:

- a. Current Patterns and Flow – Temporary, major effect on flow and patterns during construction of the project, especially in the immediate vicinity of the rock placement area. The streambank area should return to previous flow and pattern once the construction is completed.
- b. Velocity – No effect.
- c. Stratification - No effect.

3. Normal Water Level Fluctuations – No effect.

4. Salinity Gradients – No effect.

5. Actions That Will Be Taken To Minimize Impacts: Best management practices will be used during construction, including a cofferdam which will allow the project to be constructed in the dry to keep the turbidity and sediment moving downstream to a minimum. In addition, any new created streambank will be seeded or planted as soon as possible.

C. Suspended Particulate/Turbidity Determinations.

1. Expected Changes in Suspended Particulates and Turbidity Levels in Vicinity of Fill Site: Temporary, major effect during the construction of the project. Turbidity should return to normal levels after project completion.
2. Effects on Chemical and Physical Properties of the Water Column:
  - a. Light Penetration: No effect.
  - b. Dissolved Oxygen: Minor effect.
  - c. Toxic Metals and Organics: No effect.
  - d. Pathogens: No effect.
  - e. Aesthetics: Temporary, major effects limited to the construction period.
  - f. Temperature: Temporary, minor effect.
3. Effects on Biota:
  - a. Primary Production, Photosynthesis: Temporary, major effect on any aquatic vegetation in the project area. Primary production should return to pre-project levels shortly after construction.
  - b. Suspension/Filter Feeders: Temporary, major effect on filter feeders during construction. Suspension/Filter Feeders should return to pre-project levels shortly after construction.
  - c. Sight feeders: Temporary, major effect sight feeders (e.g., fish) during construction activities due to turbidity. Sight feeders should be able to return to pre-project activities shortly after construction.
4. Actions Taken to Minimize Impacts: Best management practices will be used during construction, including a cofferdam which will allow the project to be constructed in the dry to keep the turbidity and sediment moving downstream to a minimum. In addition, any new created streambank will be seeded or planted as soon as possible.

D. Contaminant Determinations.

N/A

E. Aquatic Ecosystem and Organism Determinations.

1. Effects on Plankton: Temporary, major effect on any aquatic vegetation in the project area. Primary production should return to pre-project levels shortly after construction.
2. Effects on Benthos: Temporary, major effect on any benthos in the project area.

Benthos should recover to pre-project levels shortly after construction (<1 year).

3. Effects on Nekton: N/A
4. Effects on Aquatic Food Web: Temporary, major effect on the food web in the project area. The food web should return to pre-project levels shortly after construction.
5. Effects on Special Aquatic Sites:
  - (a) Sanctuaries and Refuges: None.
  - (b) Wetlands: None.
  - (c) Tidal flats: None.
  - (d) Vegetated Shallows: None.
6. Threatened and Endangered Species: No effect.
7. Other Wildlife: Temporary, minor effect.
8. Actions to Minimize Impacts: Best management practices will be used during construction, including a cofferdam which will allow the project to be constructed in the dry to keep the turbidity and sediment moving downstream to a minimum. In addition, any new created streambank will be seeded or planted as soon as possible.

F. Proposed Disposal Site Determinations (N/A – no dredging will be conducted)

1. Mixing Zone Determinations:
  - a. Depth of water:
  - b. Current velocity:
  - c. Degree of turbulence:
  - d. Stratification:
  - e. Discharge vessel speed and direction:
  - f. Rate of discharge:
  - g. Dredged material characteristics:
2. Determination of Compliance with Applicable Water Quality Standards:

A section 401 Water Quality Certificate will be obtained from PADEP for this project prior to construction.
3. Potential Effects on Human Use Characteristics:
  - a. Municipal and Private Water Supply: No anticipated effect.
  - b. Recreational and Commercial Fisheries: Temporary, minor effect during



construction.

- c. Water Related Recreation: Temporary, minor effect.
- d. Aesthetics: Temporary, minor effect.
- e. Parks, National and Historical Monuments, National Seashore, Wilderness Areas, Research Sites, and Similar Preserves: No effect.

G. Determination of Cumulative Effects on the Aquatic Ecosystem.

No significant adverse effects are anticipated.

H. Determination of Secondary Effects on the Aquatic Ecosystem.

No significant secondary effects are anticipated.

III. FINDINGS OF COMPLIANCE OR NON-COMPLIANCE WITH THE RESTRICTIONS ON DISCHARGE

- A. Adaptation of the Section 404(b)(1) Guidelines to this evaluation - No significant adaptation of the guidelines were made relative to this evaluation.
- B. Evaluation of Availability of Practicable Alternatives to the Proposed Discharge Site Which Would Have Less Adverse Impact on the Aquatic Ecosystem - The preferred plan was determined from a detailed evaluation of alternatives to have the least amount of environmental impacts with the best chance for solving the project purpose and need.
- C. Compliance With Applicable State Water Quality Standards - The preferred plan is not expected to violate any applicable state water quality standards in Pennsylvania.
- D. Compliance With Applicable Toxic Effluent Standards or Prohibition Under Section 307 of the Clean Water Act - The proposed discharge is not anticipated to violate the Toxic Effluent Standards of Section 307 of the Clean Water Act.
- E. Compliance With Endangered Species Act of 1973 -The preferred plan will comply with the Endangered Species Act of 1973. Informal Section 7 consultation with the U.S. Fish and Wildlife Service will be completed on this project prior to construction.
- F. Compliance With Specified Protection Measures for Marine Sanctuaries Designated by the Marine Protection, Research, and Sanctuaries Act of 1972 - No Marine Sanctuaries, as designated in the Marine Protection, Research, and Sanctuaries Act of 1972, are located within the project area.
- G. Evaluation of Extent of Degradation of Waters of the United States - The preferred plan will not result in significant adverse effects on human health and welfare, including municipal and private water supplies, and recreational and commercial fishing, plankton, fish and shellfish, wildlife, and special aquatic sites. Significant adverse impacts on aquatic ecosystem diversity, productivity and stability, and recreation, aesthetics and economic values will not occur as a result of the project.
- H. Appropriate and Practicable Steps Taken to Minimize Potential Adverse Impacts of the

Discharge on the Aquatic Ecosystem - Appropriate steps (as described above) will be taken to minimize potential adverse impacts of discharging material in the aquatic ecosystem.

## 10.0 References

Hellawell, J. M. 1986. Biological Indicators of Freshwater Pollution and Environmental Management. Elsevier Applied Science, London, England.

Stroud Water Research Center. 2012. Website.

<http://www.stroudcenter.org/research/projects/schuylkill/intro.shtm>

Pennsylvania Fish and Boat Commission. 2009. Biologist Report for the Schuylkill River in Montgomery County, PA.

Natural Lands Trust, Patrick Center of Environmental Research, and The Conservation Fund. 2001. Schuylkill Watershed Conservation Plan. 249 pages.

U.S. Environmental Protection Agency. Green Book. March 2012.

<http://www.epa.gov/air/oaqps/greenbk/gntc.html>

**11.0 CLEAN AIR ACT STATEMENT OF CONFORMITY**

**CLEAN AIR ACT STATEMENT OF CONFORMITY  
NORTH COVENTRY STREAM BANK STABILIZATION PROJECT  
CHESTER COUNTY, PENNSYLVANIA**

I have determined that the selected plan conforms to the applicable State Implementation Plan (SIP). The Environmental Protection Agency had no adverse comments under their Clean Air Act authority. No negative comments from the air quality management district were received during coordination of the draft environmental assessment. The selected plan would comply with Section 176 (c)(1) of the Clean Air Act Amendments of 1990.



Michael A. Bliss, P.E.  
Lieutenant Colonel, Corps of Engineers  
District Commander

03JUL14

Date

**Appendix A**  
**Conceptual Design**



































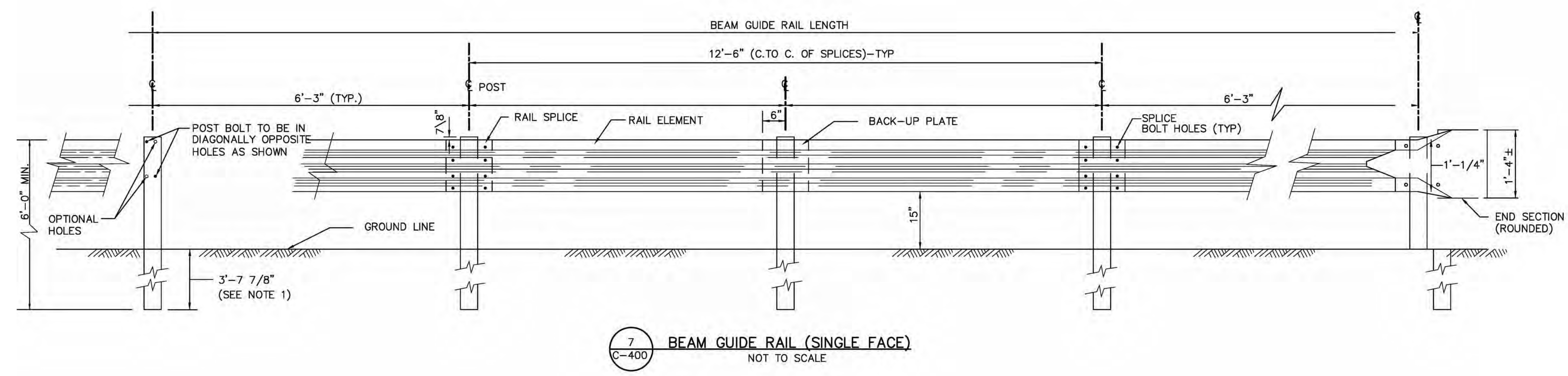
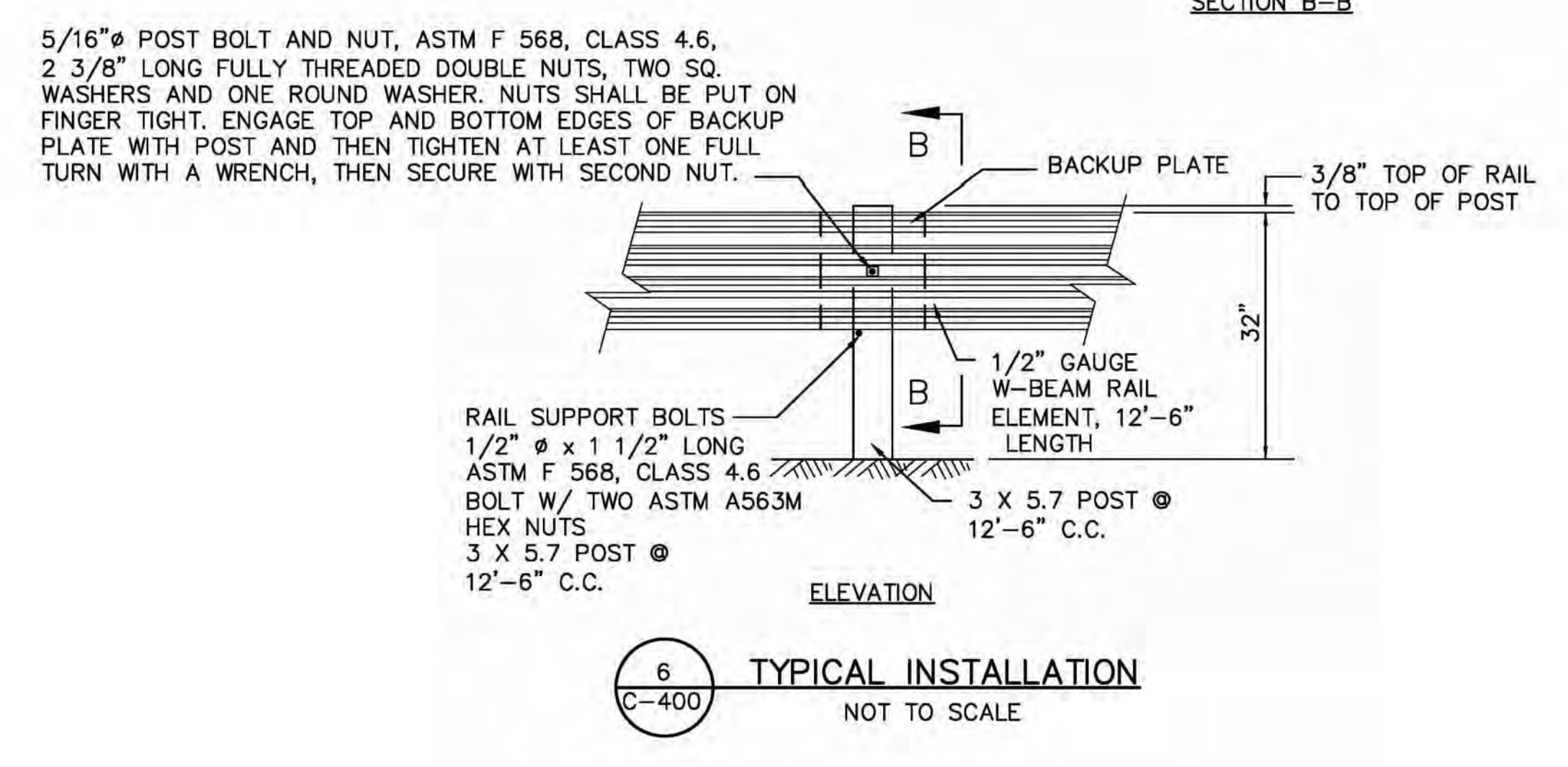
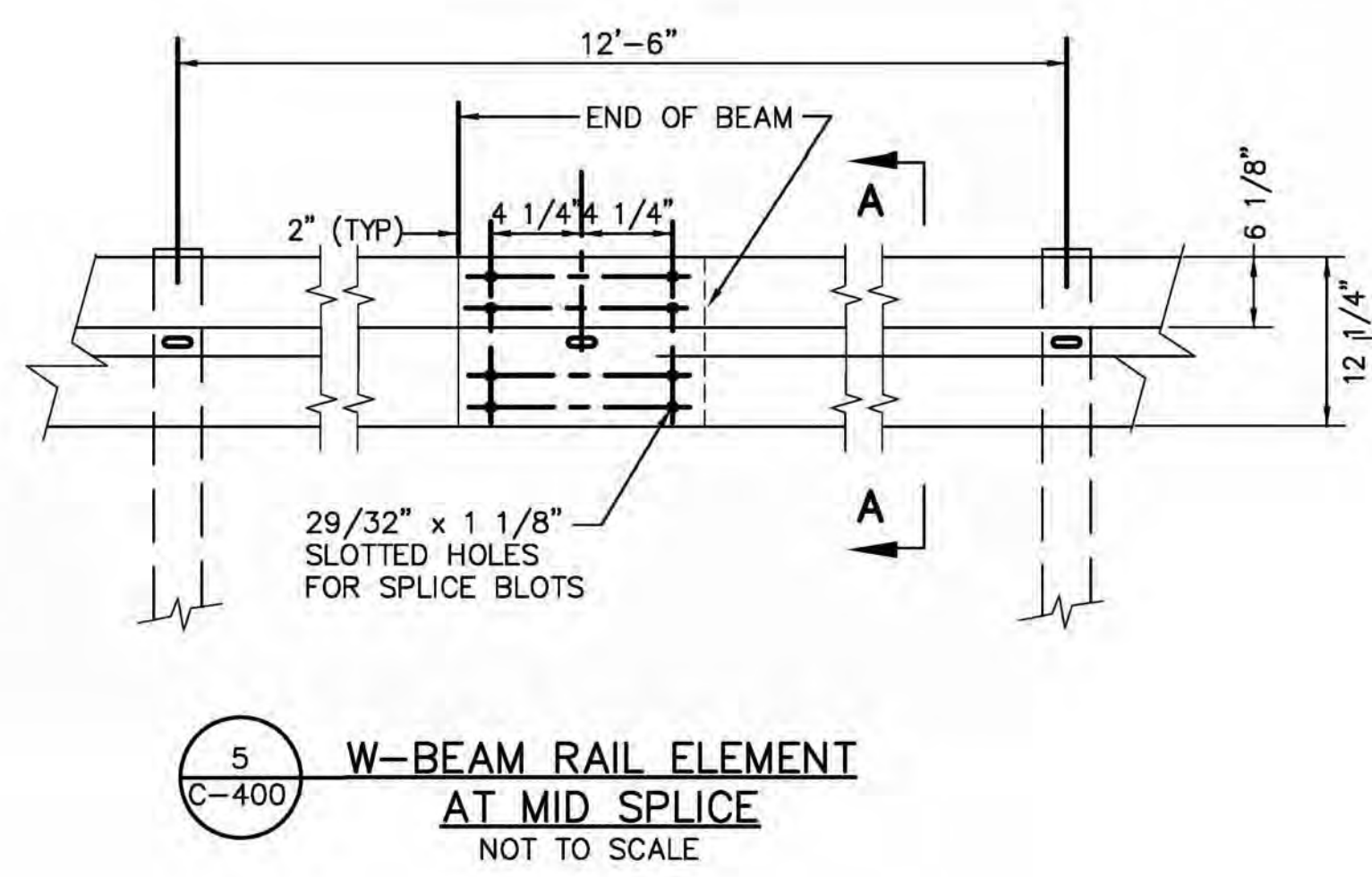
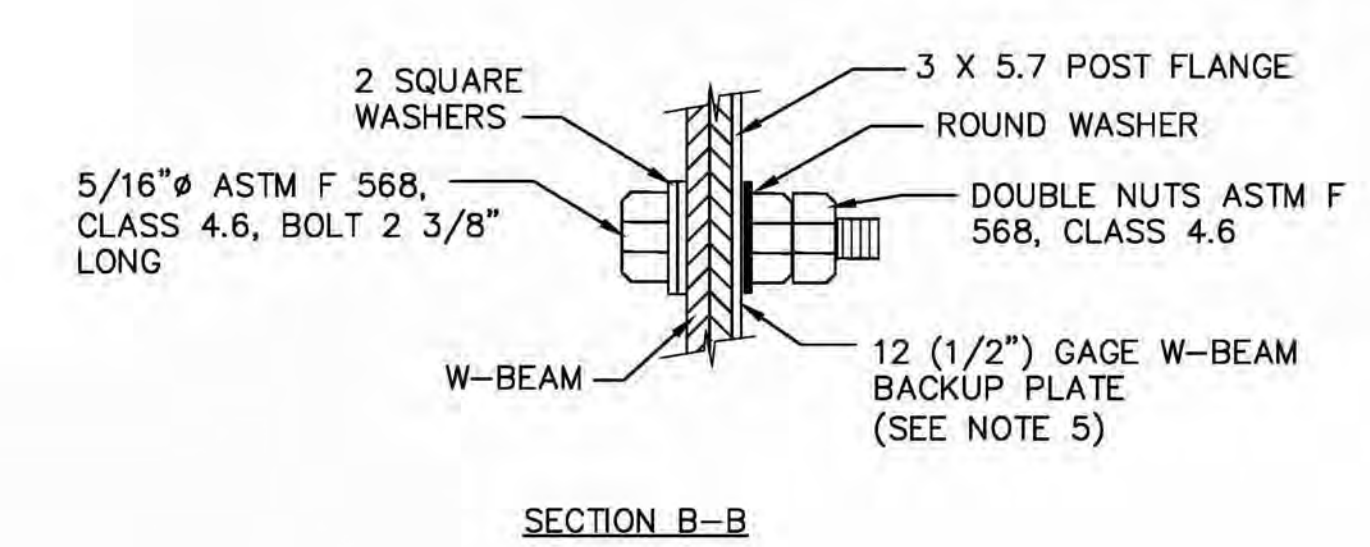
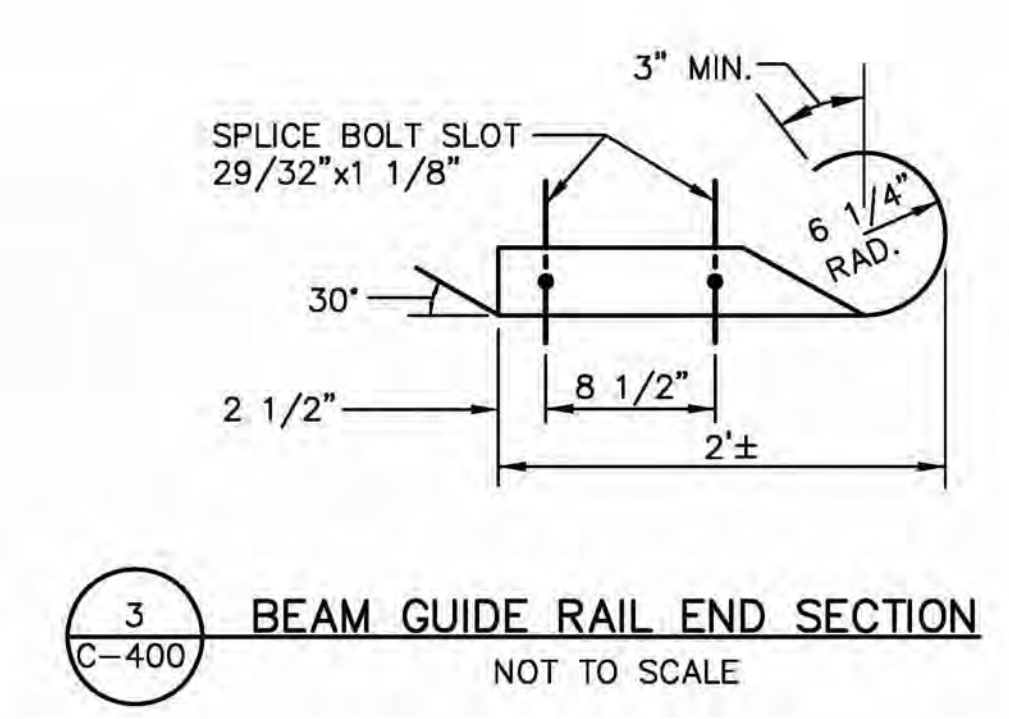
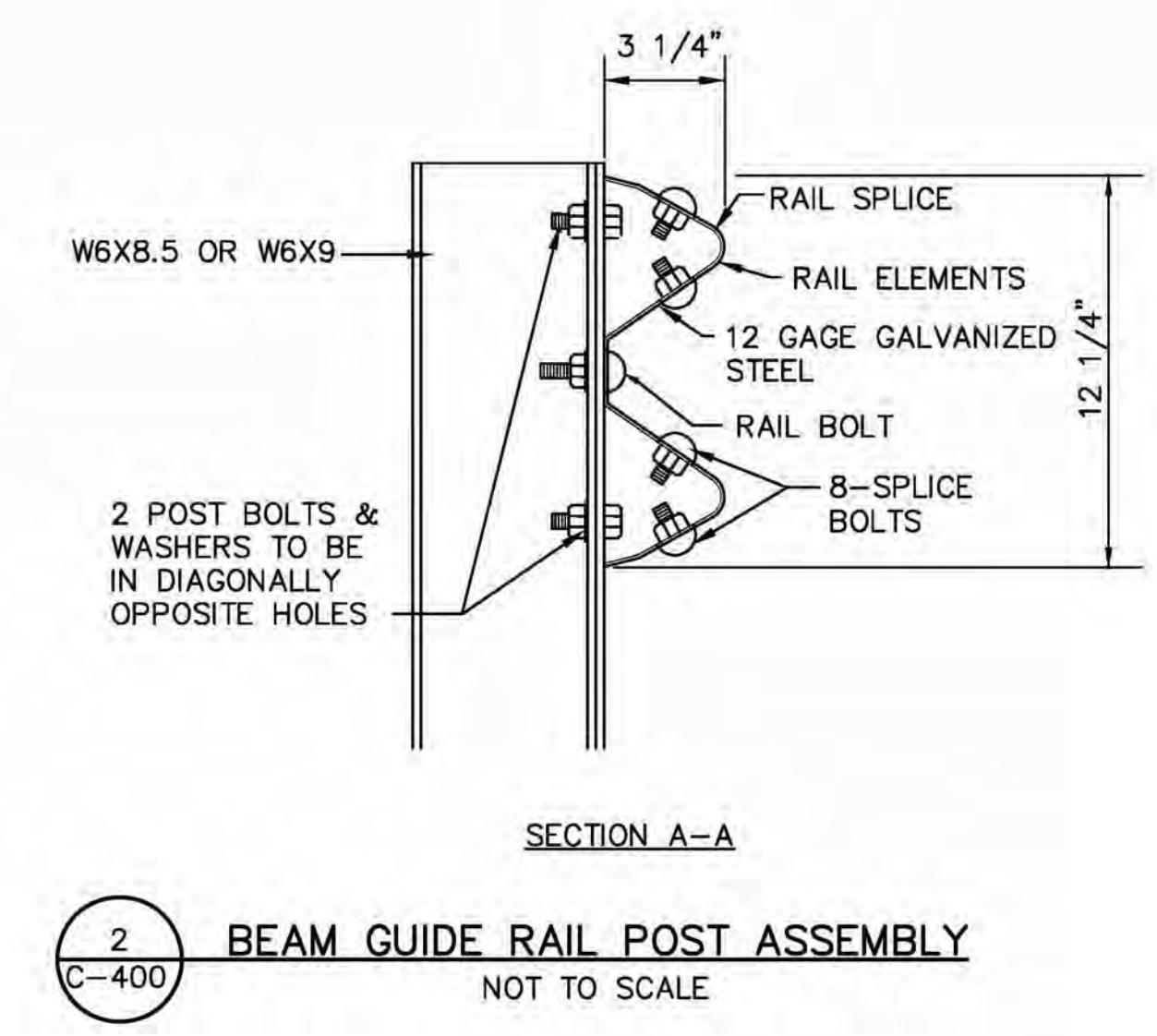
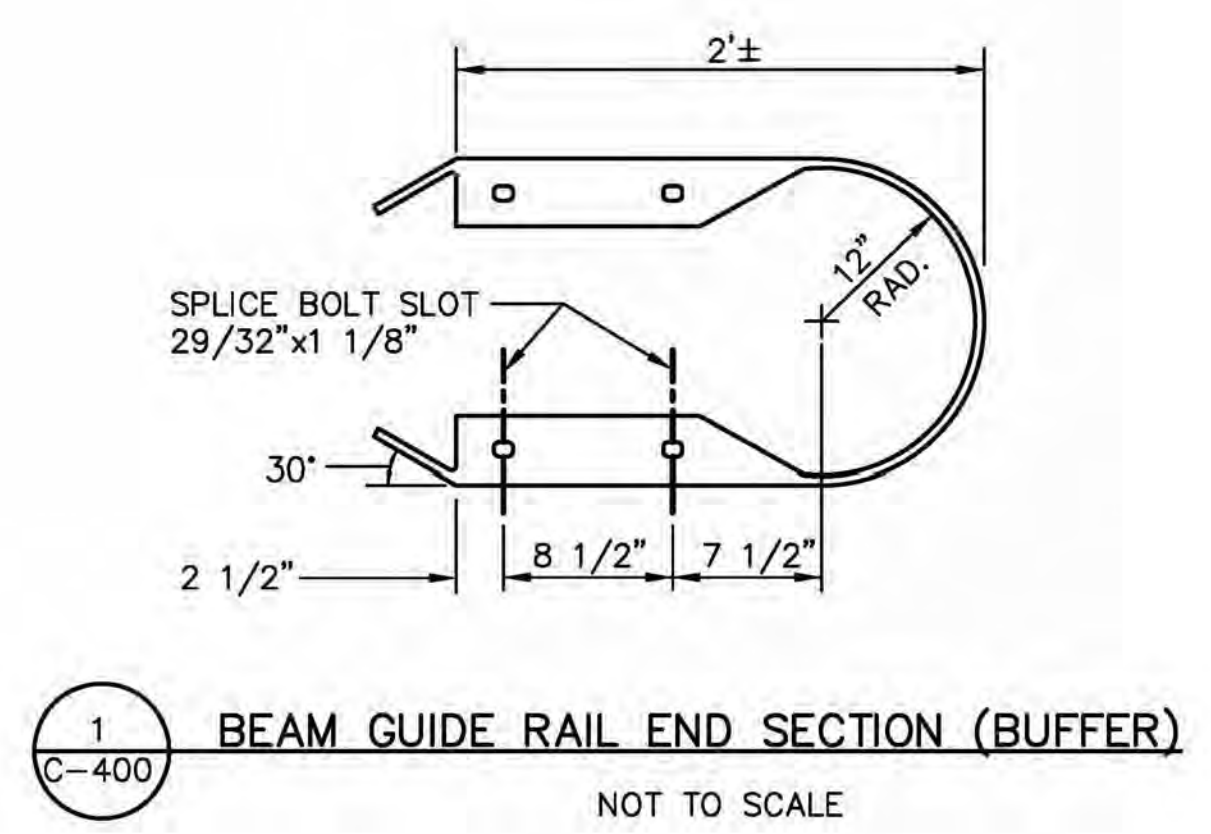

**NOTES:**

- WHERE CLEARANCE RESTRICTIONS PREVENT USE OF A 2' MIN. HORIZONTAL DISTANCE, POSTS SHALL HAVE A MINIMUM LENGTH OF 7' BELOW THE EXISTING GROUND ELEVATION.
- PROVIDE MATERIALS AND CONSTRUCTION MEETING THE REQUIREMENTS OF PUBLICATION 408, SECTION 620.
- THE 3 3/8" x 2 1/4" COLD FORMED CHANNEL POST, S3 x 5.7 POST AND ALUMINUM ALLOY POST MAY BE BID AS ALTERNATES FOR TYPE 2 WEAK POST GUIDE RAIL SYSTEM; HOWEVER, MIXING OF DIFFERENT POSTS IS NOT ACCEPTABLE WITHIN A PROJECT.
- DURING ERECTION, USE SUPPORT BOLTS TO SUPPORT THE RAIL ELEMENT UNTIL THE 5/16" POST BOLTS ARE PROPERLY TORQUED. LEAVE SUPPORT BOLTS IN PLACE AFTER CONSTRUCTION.
- ATTACH W-BEAM RAIL ELEMENT TO EACH POST. SPLICE ONLY AT MID-SPAN AND LAP IN DIRECTION OF TRAFFIC.
- ALL DIMENSIONS ARE IN U.S. CUSTOMARY UNITS.
- USE 12" BACKING PLATES FOR THE W-BEAM RAIL ELEMENTS AT ALL POSTS WITH THE SAME SECTION AS THE W-BEAM RAIL ELEMENT.

| Rev. | Date | MM/DD/YYYY | By | Checked | Drawn | Scale | File Name | Plot Date | Plot Scale |
|------|------|------------|----|---------|-------|-------|-----------|-----------|------------|
|      |      |            |    |         |       |       |           |           |            |

U.S. ARMY ENGINEER DISTRICT PHILADELPHIA  
CORPS OF ENGINEERS  
PHILADELPHIA, PENNSYLVANIA

DESIGNED BY: DTB  
DRAWN BY: DTB  
CHECKED BY: DTB  
SUBMITTED BY: DTB  
CHIEF, ARCH. BRANCH

NORTH COVENTRY TOWNSHIP - SCHUYLKILL RIVER PROJECT  
NORTH COVENTRY, PENNSYLVANIA  
GUIDE RAIL DETAILS

Sheet drawing number:  
**C-400**

## **Appendix B**

### **Relevant Correspondence**





# United States Department of the Interior



FISH AND WILDLIFE SERVICE  
Pennsylvania Field Office  
315 South Allen Street, Suite 322  
State College, Pennsylvania 16801-4850

January 4, 2013

Minas M. Arabatzis  
U.S. Army Corps of Engineers  
Wanamaker Building  
100 Penn Square East  
Philadelphia, PA 19107

RE: USFWS Project #2013-0265

Dear Mr. Arabatzis:

This responds to your letter of June 14, 2012, requesting information about federally listed and proposed endangered and threatened species within the area affected by the proposed North Coventry stream stabilization project located in North Coventry Township, Chester County, Pennsylvania. The proposed project is within the known range of the bog turtle (*Clemmys muhlenbergii*), a species that is federally listed as threatened. The following comments are provided pursuant to the Endangered Species Act of 1973 (87 Stat. 884, as amended; 16 U.S.C. 1531 *et seq.*) to ensure the protection of endangered and threatened species.

Based on a review of the project information, including the size of the project area, the disturbed Schuylkill River area and anticipated impacts to wetlands, we have determined that the effects of the project on the bog turtle are insignificant or discountable.

This response relates only to endangered and threatened species under our jurisdiction, based on an office review of the proposed project's location. No field inspection of the project area has been conducted by this office. Consequently, this letter is not to be construed as addressing other Service concerns under the Fish and Wildlife Coordination Act or other authorities.

*To avoid potential delays in reviewing your project, please use the above-referenced USFWS project tracking number in any future correspondence regarding this project.*

If you have any questions regarding this matter, please contact Kayla Easler of my staff at 814-234-4090.

Sincerely,

A handwritten signature in black ink, appearing to read "David Stilwell". The signature is fluid and cursive, with a long horizontal flourish extending to the right.

for David Stilwell  
Acting Supervisor



# United States Department of the Interior



FISH AND WILDLIFE SERVICE  
Pennsylvania Field Office  
315 South Allen Street, Suite 322  
State College, Pennsylvania 16801-4850

February 14, 2013

Minas M. Arabatzis  
(ATTN: Mark Eberle)  
U.S. Army Corps of Engineers  
Wanamaker Building  
100 Penn Square East  
Philadelphia, PA 19107

RE: USFWS Project #2013-0265, CPA #2013-0043

Dear Mr. Arabatzis:

This responds to your email inquiry of January 24, 2013, requesting information about fish and wildlife resources within the area affected by the proposed North Coventry stream stabilization project located on the Schuylkill River in North Coventry Township, Chester County, Pennsylvania. The Army Corps of Engineers (Corps) proposes to stabilize the west bank of the Schuylkill River, using a combination of rip-rap, weirs, and vegetative cover. The proposed project would impact 1,900 linear feet of stream, streambank, and riparian buffer. We have previously provided information on federally listed and proposed endangered and threatened species on this project by letter dated January 4, 2013 (enclosed).

The following report is provided pursuant to the Migratory Bird Treaty Act (MBTA, 16 U.S.C. 703-712; Ch. 128; July 13, 1918; 40 Stat. 755, as amended) to ensure the protection of migratory bird species, and the Fish and Wildlife Coordination Act (48 Stat. 401, as amended; 16 U.S.C. 661 *et seq.*) to ensure protection of fish and wildlife resources.

## Project Design

**Erosion control matting.** If erosion control matting is used as part of soil stabilization measures, we encourage the use of coconut or other natural fiber mesh rather than plastic monofilament. Monofilament mesh has been shown to trap and kill herptiles and can also entangle and kill birds.

**Turbidity and Best Management Practices.** The Corps should take measures to reduce turbidity that could adversely affect the downstream habitat. Turbidity reduction measures should be taken prior to any construction or excavation. We support the use of the proposed turbidity curtains. Other turbidity measures may include installing silt fence, mulch filter tubes,

or straw wattles before starting the project, and keeping them in place until construction is completed and the area is stabilized. Additional best management practices include:

- Performing backfilling operations in a manner that minimizes turbidity;
- Eliminating vehicle and heavy equipment excursions into streambeds;
- Conducting stream work from the streambanks;
- Expediting all restoration efforts directly after construction to reduce run-off into aquatic areas downstream;
- Stabilizing new construction as the project progresses;
- Stockpiling materials used for stream bank reconstruction on a clean surface (*i.e.*, limestone gravel or pavement) prior to use, to minimize incidental conveyance of fine particulate materials; and
- Storing any excavated material at a predetermined, confined, upland site to avoid runoff into aquatic areas.

#### Other Fish and Wildlife Resources

- **Riparian Plantings.** Riparian vegetation plays an important role in protecting streams, mitigating or controlling point and non-point source pollution to the Schuylkill River, reducing erosion and sedimentation, protecting water quality, maintaining the water table, controlling flooding, and providing shade and cover. Consistent with the PA Department of Environmental Protection's Riparian Forest Buffer Guidance (November 27, 2010), we recommend you conserve and restore forest and riparian habitat on the project site wherever possible. To be protective of migratory birds and their habitat, we recommend that you protect trees within the existing riparian buffer, and minimize tree removal.

We appreciate your selection of native plant species incorporated into the project plan. We recommend planting trees and shrubs together in clumped or clustered groupings rather than linearly, or in grid patterns, to allow for maximum benefit to wildlife.

- **Monitoring and Maintenance.**
  - ***Geomorphological Monitoring.*** We recommend that you develop an appropriate monitoring plan for the project that clearly defines the thresholds of success and failure from a physical standpoint, with reference to the project objectives. Additionally, the monitoring plan should identify the party(ies) responsible for conducting the monitoring. The monitoring plan should include the following standard components: a post-construction as-built survey, longitudinal profile, structure and bank stability evaluations using monumented cross-sections and monumented benchmarks, photo documentation with monumented photo points, and visual inspections of stream stability. Comparisons of all data collected should be made with respect to the design criteria.
  - ***Maintenance Plan.*** We also recommend that you develop a maintenance plan that clearly states how erosion will be addressed; who will address erosion problems; when maintenance will be required; the source of maintenance funding;

means/methods/plans for structure repair in the event that a structure is altered or destroyed by large storm events or ice (e.g., a maintenance bond); and a contingency plan should the project not attain a stable cross section, profile and pattern, or if streambanks are not stabilized.

*To avoid potential delays in reviewing your project, please use the above-referenced USFWS project tracking number in any future correspondence regarding this project.*

If you have any questions regarding this matter, please contact Jennifer Kagel of my staff at 814-234-4090.

Sincerely,

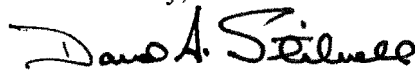
A handwritten signature in black ink that reads "David A. Stilwell". The signature is written in a cursive style with a large, prominent "D" and "S".

David Stilwell  
Acting Field Office Supervisor

Enclosure



# Pennsylvania Fish & Boat Commission

Division of Environmental Services  
Natural Diversity Section  
450 Robinson Lane  
Bellefonte, PA 16823-9620  
(814) 359-5237 Fax: (814) 359-5175

May 10, 2012

**IN REPLY REFER TO**  
SIR #38572

MINAS ARABATZIS  
DEPARTMENT OF THE ARMY  
WANAMAKER BUILDING  
100 PENN SQUAGE EAST  
PHILADELPHIA, PA 19107-3391

**Re: Species Impact Review (SIR) – Rare, Candidate, Threatened and Endangered Species  
STREAM BANK STABILIZATION, SCHUYLKILL RIVER ALONG RIVER ROAD  
NORTH COVENTRY Township, CHESTER County, Pennsylvania**

Dear Mr. ARABATZIS:

The staff of the Natural Diversity Section reviewed your recent correspondence. Based on records maintained in the Pennsylvania Natural Diversity Inventory (PNDI) database and our own files, the state threatened eastern redbelly turtle (*Pseudemys rubriventris*) is known from the vicinity of the project site.

The redbelly turtle is one of Pennsylvania's largest native aquatic turtles. This turtle species is known to inhabit relatively large, deep streams, rivers, ponds, lakes and marshes with permanent water and ample basking sites. Redbelly turtles are restricted to the southcentral and southeastern regions of the Commonwealth. The existence of this turtle species is threatened by habitat destruction, poor water quality, and competition with aggressive non-native turtle species that share its range and habitat (e.g., red-eared slider, *Trachemys scripta elegans*).

According to the information you provided as well as our review of aerial photographs, I do not expect the proposed bank stabilization measures to impact the redbelly turtle. Therefore, I do not foresee the proposed project resulting in adverse impacts to the eastern redbelly turtle or any other rare or protected species under Pennsylvania Fish and Boat Commission jurisdiction.

Note that this office performed no field inspection of the project area. Consequently, comments in this letter are not meant to address other issues or concerns that might arise concerning matters under Pennsylvania Fish and Boat Commission jurisdiction or that of other authorities. Thank you for your cooperation and attention to this matter of threatened and endangered species conservation.

Sincerely,

Christopher Urban, Chief  
Natural Diversity Division

CAU/KDG/kn

**Our Mission:**

[www.fishandboat.com](http://www.fishandboat.com)

*To protect, conserve and enhance the Commonwealth's aquatic resources and provide fishing and boating opportunities.*



UNITED STATES DEPARTMENT OF COMMERCE  
National Oceanic and Atmospheric Administration  
NATIONAL MARINE FISHERIES SERVICE  
NORTHEAST REGION  
55 Great Republic Drive  
Gloucester, MA 01930-2276

Minas M. Arabatzis, Chief  
Planning Division  
U.S. Army Corps of Engineers  
Philadelphia District  
Wanamaker Building  
100 Penn Square East  
Philadelphia, PA 19107-3390

MAY 7 2012

ATTN: Mr. Mark Eberle

Dear Mr. Arabatzis:

This responds to your letter dated April 10, 2012, requesting agency participation in the scoping of a streambank stabilization study along the Schuylkill River in North Coventry Township, Chester County, Pennsylvania. In accordance with the National Environmental Policy Act of 1969, as amended, the U.S. Army Corps of Engineers, Philadelphia District (Corps) is working with North Coventry Township to evaluate alternatives for streambank protection for the Schuylkill River along River Road in Chester County. The overall goal of the project is to restore bank stability and to protect River Road from eventual failure.

Based on our review, no habitat or trust resources under our jurisdiction exist within the project area. However, American shad (*Alosa sapidissima*), American eel (*Anguilla rostrata*) blueback herring (*Alosa aestivalis*), white perch (*Morone americana*), gizzard shad (*Dorosoma cepedianum*) and striped bass (*Morone saxatilis*), use the waterway downstream of the proposed project area as a migratory pathway and could be adversely impacted by the proposed project.

Although we appreciate the opportunity to join the Philadelphia District's ongoing plan formulation process, we are unable to do so at this time due to our limited staff and lack of resources in the project area. We do, however, support the Corps efforts to stabilize Schuylkill River embankments and protect the surrounding communities from potential flooding risks.

We look forward to continued coordination with the Corps as subsequent phases of the project are developed. If you have any questions, please contact Brian May at 732 872-3116.

Sincerely,

Christopher J. Boelke  
Mid-Atlantic Field Office Supervisor

cc: PRD - J. Crocker  
RC - B. Bearmore







**UNITED STATES DEPARTMENT OF COMMERCE**  
**National Oceanic and Atmospheric Administration**  
NATIONAL MARINE FISHERIES SERVICE  
NORTHEAST REGION  
55 Great Republic Drive  
Gloucester, MA 01930-2276

APR 18 2012

Minas M. Arabatzis, Chief  
Department of the Army  
Philadelphia District, Corps of Engineers  
Wanamaker Building-100 Penn Square East  
Philadelphia, PA 19107-3390

Re: Stream bank protection, Schuylkill River

Dear Mr. Arabatzis,

This is in response to your letter dated April 10, 2012, requesting information on the presence of species listed by NOAA's National Marine Fisheries Service (NMFS) in the vicinity of proposed stream bank protection for the Schuylkill River along River Road in North Coventry Township, Chester County, Pennsylvania.

No federally listed or proposed threatened or endangered species and/or designated critical habitat for listed species under the jurisdiction of NMFS are known to exist in the vicinity of your proposed project. As such, NMFS Protected Resources Division does not intend to offer additional comments on this proposal. Should project plans change or new information become available that changes the basis for this determination, further coordination should be pursued. If you have any questions regarding these comments, please contact Danielle Palmer at (978) 282-8468.

Sincerely,

Kimberly Damon-Randall  
Acting Assistant Regional Administrator  
for Protected Resources

EC: Palmer  
File Code: Sec 7 No Species Present 2012





UNITED STATES ENVIRONMENTAL PROTECTION AGENCY  
REGION III  
1650 Arch Street  
Philadelphia, Pennsylvania 19103-2029

MAY 07 2012

Mark Eberle  
Department of the Army  
Philadelphia District, Corps of Engineers  
Environmental Resources Branch  
Wanamaker Building, 100 Penn Square East  
Philadelphia, Pennsylvania 19107-3391

RE: Emergency Stream Bank Stabilization, Schuylkill River along River Road, North Coventry Township, Pennsylvania

Dear Mr. Eberle:

EPA has received and reviewed your April 10, 2012 letter regarding the Emergency Stream Bank Stabilization of the Schuylkill River along River Road in North Coventry Township, Pennsylvania. EPA is interested in participating the National Environmental Policy Act (NEPA) scoping of this study; however it is not clear what type of NEPA documentation that scoping efforts will inform. The proposed project consists of stabilizing the west bank of the Schuylkill River along River Road using Longitudinal Peak Stone Toe Protection (LPSTP) between State Highway 100 overpass and Hanover Street. Enclosure #1, provided with the April 10, 2012 scoping letter, details five alternatives, including the no action as alternative one. Alternative two involves making the existing River Road a one-way road; alternative three involves the relocation of River Road; alternative four involves armoring the stream bank using rip rap; and alternative five armoring/bioengineering combination using LPSTP. Alternative five has been identified as the preferred alternative.

At this point in the early scoping process detailed alternatives have been presented, and even a preferred alternative has been identified. It is not clear how this alternative has already been selected prior to the start of agency and public scoping. EPA recommends that each alternative, or others that have not been included in Enclosure #1, be analyzed equally in order to keep with the spirit of NEPA, which is meant to inform the decision-making process. The scoping process is typically used to identify issues to explore during the alternatives analysis and impact assessment. If information is discovered or identified during scoping changes will need to be made to the current analysis to address topics. Information regarding the purpose and need, alternatives analyzed, avoidance and minimization of resources, and cumulative effects for the proposed project should be included in the NEPA documentation. The purpose and need statement is important because it helps explain why the proposed action is being undertaken and what objectives the project intends to achieve. The purpose of the proposed action is typically the specific objective of the activity. The need should explain the underlying problem for why the project is necessary. Information on the stability of the road, bank stability and erosion, and details of damage caused by recent hurricanes and tropical storms should be included and



discussed. Based on the limited information on project purpose and need that has been provided, it appears that there are multiple alternatives that may meet project purpose and need.

The alternatives analysis considers relocating the existing road. Different possible alignments for a relocated road should be discussed in the NEPA document. It should also include an evaluation on whether a partial property buy out is feasible, consider the use of a service road or shared driveways for resident access, as well as tie ins to adjacent and neighboring roadways. Another alternative presented involves making the existing two-lane road into a one-way road. The alternative description provided indicates that erosion of the river bank in the project area is partially due to past relocation of the mouth of Manatawny Creek across from the project area. Potential reasons for bank erosion, including the Manatawny Creek project that was mentioned, should also be evaluated in the purpose and need. Please clarify how that project has affected the proposed project area. The one-way road alternative should include if pavement would be removed, the benefits of an enhanced vegetative buffer, as well as discuss need for the proposed pedestrian trail.

The NEPA document should evaluate possible impacts on the Schuylkill River and associated floodplain, riparian habitat/bank vegetation, fisheries, and rare, threatened and endangered species. Avoidance and minimization measures should be taken to reduce adverse impacts to natural resources, particularly to streams, wetlands and floodplains. The use of different construction techniques for the preferred alternative and other alternatives should be evaluated, including construction from land or from the water. In stream avoidance and minimization should be fully evaluated using a range of techniques, including cofferdams, the currently preferred turbidity curtains, and other methods. The project area is located in an air non-attainment area for ozone and PM-2.5, which should be evaluated in the document.

An evaluation of community impacts, including noise, light and possible traffic impacts should be included in the NEPA document. Visual impacts to River Road users and residents, as well as Schuylkill River Trail users, should be evaluated. Environmental justice (EJ) should also be evaluated, including the identification of potential communities of concern, and meaningful and timely community involvement, public outreach, and access to information. Consideration should also be given to all potential impacts to at-risk populations, as well as consideration to sensitive subpopulations, possibly including elderly, children and others.

Thank you for coordinating with EPA on this project. We look forward to working with you on this project as more information becomes available. If you have any questions and would like to discuss our comments, the staff contact for this project is Ms. Alaina DeGeorgio; she can be reached at 215-814-2741 or [degeorgio.alaina@epa.gov](mailto:degeorgio.alaina@epa.gov).

Sincerely,



Barbara Rudnick  
NEPA Team Leader  
Office of Environmental Programs



# 1. PROJECT INFORMATION

Project Name: **North Coventry Streambank Stabilization Project**

Date of review: **5/25/2012 2:33:45 PM**

Project Category: **In-stream / Riverine Activities and Projects, Other**

Project Area: **3.8 acres**

County: **Chester** Township/Municipality: **North Coventry**

Quadrangle Name: **POTTSTOWN** ~ ZIP Code: **19465**

Decimal Degrees: **40.242257 N, -75.655374 W**

Degrees Minutes Seconds: **40° 14' 32.1" N, -75° 39' 19.3" W**

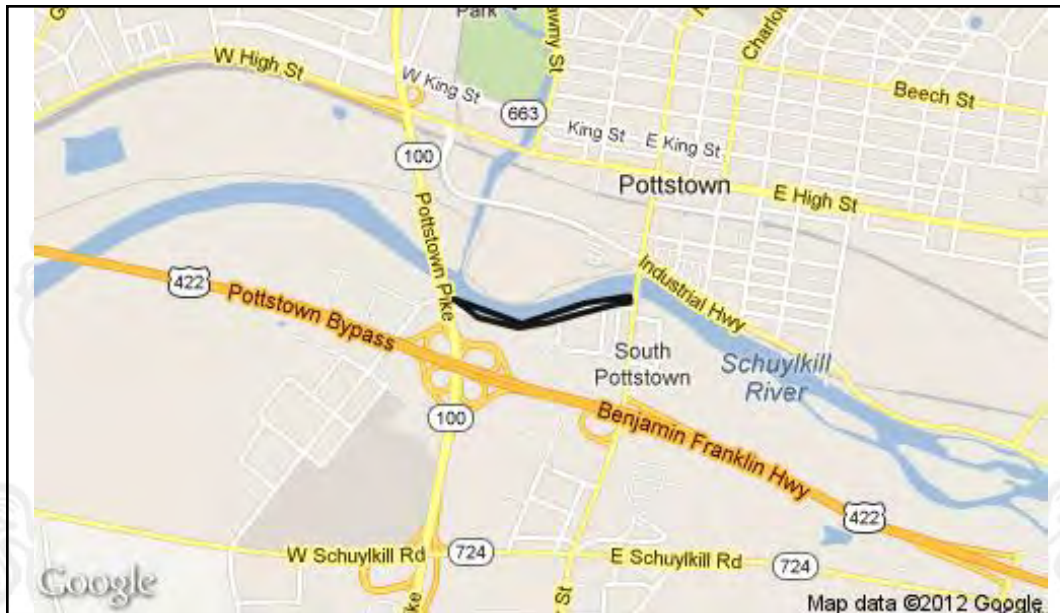

# 2. SEARCH RESULTS

| Agency  | Results                 | Response   |
|---|-------------------------|--|
| PA Game Commission                                  | No Known Impact         | No Further Review Required                             |
| PA Department of Conservation and Natural Resources | No Known Impact         | No Further Review Required                             |
| PA Fish and Boat Commission                         | <b>Potential Impact</b> | <b>FURTHER REVIEW IS REQUIRED, See Agency Response</b> |
| U.S. Fish and Wildlife Service                      | No Known Impact         | No Further Review Required                             |

As summarized above, Pennsylvania Natural Diversity Inventory (PNDI) records indicate there may be potential impacts to threatened and endangered and/or special concern species and resources within the project area. If the response above indicates "No Further Review Required" no additional communication with the respective agency is required. If the response is "Further Review Required" or "See Agency Response," refer to the appropriate agency comments below. Please see the DEP Information Section of this receipt if a PA Department of Environmental Protection Permit is required.

Note that regardless of PNDI search results, projects requiring a Chapter 105 DEP individual permit or GP 5, 6, 7, 8, 9 or 11 in certain counties (Adams, Berks, Bucks, Carbon, Chester, Cumberland, Delaware, Lancaster, Lebanon, Lehigh, Monroe, Montgomery, Northampton, Schuylkill and York) must comply with the bog turtle habitat screening requirements of the PASPGP.

### 3. AGENCY COMMENTS

Regardless of whether a DEP permit is necessary for this proposed project, any potential impacts to threatened and endangered species and/or special concern species and resources must be resolved with the appropriate jurisdictional agency. In some cases, a permit or authorization from the jurisdictional agency may be needed if adverse impacts to these species and habitats cannot be avoided.

These agency determinations and responses are **valid for one year** (from the date of the review), and are based on the project information that was provided, including the exact project location; the project type, description, and features; and any responses to questions that were generated during this search. If any of the following change: 1) project location, 2) project size or configuration, 3) project type, or 4) responses to the questions that were asked during the online review, the results of this review are not valid, and the review must be searched again via the PNDI Environmental Review Tool and resubmitted to the jurisdictional agencies. The PNDI tool is a primary screening tool, and a desktop review may reveal more or fewer impacts than what is listed on this PNDI receipt. The jurisdictional agencies **strongly advise against** conducting surveys for the species listed on the receipt prior to consultation with the agencies.

#### PA Game Commission

**RESPONSE:** No Impact is anticipated to threatened and endangered species and/or special concern species and resources.

#### PA Department of Conservation and Natural Resources

**RESPONSE:** No Impact is anticipated to threatened and endangered species and/or special concern species and resources.

#### PA Fish and Boat Commission

**RESPONSE:** Further review of this project is necessary to resolve the potential impacts(s). Please send project information to this agency for review (see WHAT TO SEND).

**PFBC Species:** (Note: The PNDI tool is a primary screening tool, and a desktop review may reveal more or fewer species than what is listed below.)

**Scientific Name:** Sensitive Species\*\*

**Common Name:**

**Current Status:** Threatened

**Proposed Status:** Special Concern Species\*

**Scientific Name:** *Stygobromus pizzinii*

**Common Name:** Pizzini's Cave Amphipod

**Current Status:** Special Concern Species\*

**Proposed Status:** Special Concern Species\*

## U.S. Fish and Wildlife Service

**RESPONSE:** No impacts to **federally** listed or proposed species are anticipated. Therefore, no further consultation/coordination under the Endangered Species Act (87 Stat. 884, as amended; 16 U.S.C. 1531 *et seq.*) is required. Because no take of federally listed species is anticipated, none is authorized. This response does not reflect potential Fish and Wildlife Service concerns under the Fish and Wildlife Coordination Act or other authorities.

\* Special Concern Species or Resource - Plant or animal species classified as rare, tentatively undetermined or candidate as well as other taxa of conservation concern, significant natural communities, special concern populations (plants or animals) and unique geologic features.

\*\* Sensitive Species - Species identified by the jurisdictional agency as collectible, having economic value, or being susceptible to decline as a result of visitation.

## WHAT TO SEND TO JURISDICTIONAL AGENCIES

If project information was requested by one or more of the agencies above, send the following information to the agency(s) seeking this information (see AGENCY CONTACT INFORMATION).

### **Check-list of *Minimum Materials to be submitted:***

- \_\_\_ **SIGNED** copy of this Project Environmental Review Receipt
- \_\_\_ Project narrative with a description of the overall project, the work to be performed, current physical characteristics of the site and acreage to be impacted.
- \_\_\_ Project location information (name of USGS Quadrangle, Township/Municipality, and County)
- \_\_\_ USGS 7.5-minute Quadrangle with project boundary clearly indicated, and quad name on the map

### **The inclusion of the following information may expedite the review process.**

- \_\_\_ A basic site plan (particularly showing the relationship of the project to the physical features such as wetlands, streams, ponds, rock outcrops, etc.)
- \_\_\_ Color photos keyed to the basic site plan (i.e. showing on the site plan where and in what direction each photo was taken and the date of the photos)
- \_\_\_ Information about the presence and location of wetlands in the project area, and how this was determined (e.g., by a qualified wetlands biologist), if wetlands are present in the project area, provide project plans showing the location of all project features, as well as wetlands and streams

## 4. DEP INFORMATION

The Pa Department of Environmental Protection (DEP) requires that a signed copy of this receipt, along with any required documentation from jurisdictional agencies concerning resolution of potential impacts, be submitted with applications for permits requiring PNDI review. For cases where a "Potential Impact" to threatened and endangered species has been identified before the application has been submitted to DEP, the application should not be submitted until the impact has been resolved. For cases where "Potential Impact" to special concern species and resources has been identified before the application has been submitted, the application should be submitted to DEP along with the PNDI receipt. The PNDI Receipt should also be submitted to the appropriate agency according to directions on the PNDI Receipt. DEP and the jurisdictional agency will work

together to resolve the potential impact(s). See the DEP PNDI policy at <http://www.naturalheritage.state.pa.us>.





### 5. ADDITIONAL INFORMATION

The PNDI environmental review website is a **preliminary** screening tool. There are often delays in updating species status classifications. Because the proposed status represents the best available information regarding the conservation status of the species, state jurisdictional agency staff give the proposed statuses at least the same consideration as the current legal status. If surveys or further information reveal that a threatened and endangered and/or special concern species and resources exist in your project area, contact the appropriate jurisdictional agency/agencies immediately to identify and resolve any impacts.

For a list of species known to occur in the county where your project is located, please see the species lists by county found on the PA Natural Heritage Program (PNHP) home page ([www.naturalheritage.state.pa.us](http://www.naturalheritage.state.pa.us)). Also note that the PNDI Environmental Review Tool only contains information about species occurrences that have actually been reported to the PNHP.

### 6. AGENCY CONTACT INFORMATION

#### PA Department of Conservation and Natural Resources

Bureau of Forestry, Ecological Services Section  
400 Market Street, PO Box 8552, Harrisburg, PA.  
17105-8552  
Fax:(717) 772-0271

#### U.S. Fish and Wildlife Service

Endangered Species Section  
315 South Allen Street, Suite 322, State College, PA.  
16801-4851  
NO Faxes Please.

#### PA Fish and Boat Commission

Division of Environmental Services  
450 Robinson Lane, Bellefonte, PA. 16823-7437  
NO Faxes Please

#### PA Game Commission

Bureau of Wildlife Habitat Management  
Division of Environmental Planning and Habitat Protection  
2001 Elmerton Avenue, Harrisburg, PA. 17110-9797  
Fax:(717) 787-6957

### 7. PROJECT CONTACT INFORMATION

Name: \_\_\_\_\_  
Company/Business Name: \_\_\_\_\_  
Address: \_\_\_\_\_  
City, State, Zip: \_\_\_\_\_  
Phone:(\_\_\_\_\_) \_\_\_\_\_ Fax:(\_\_\_\_\_) \_\_\_\_\_  
Email: \_\_\_\_\_

### 8. CERTIFICATION

I certify that ALL of the project information contained in this receipt (including project location, project size/configuration, project type, answers to questions) is true, accurate and complete. In addition, if the project type, location, size or configuration changes, or if the answers to any questions that were asked during this online review change, I agree to re-do the online environmental review.

\_\_\_\_\_ date  
applicant/project proponent signature

## **Appendix C**

### **Clean Air Assessment**

#### **General Conformity Analysis**

**Table 1. Project Emission Sources and Estimated Power**

**Table 2. Emission Estimates (NO<sub>x</sub>)**

**Table 3. Emission Estimates (HC)**

**Table 4. Emission Estimates (SO<sub>2</sub>)**

**Table 5. Pollutant Emissions from Employee Vehicles**

# General Conformity Review and Emission Inventory for North Coventry Streambank Stabilization Project

## Table 1. Project Emission Sources and Estimated Power

$$\text{hp-hr} = \# \text{ of engines} * \text{hp} * \text{LF} * \text{hrs of operation}$$

Load Factor (LF) represents the average percentage of rated horsepower used during a source's operational profile

| <b>Equipment/Engine Category</b>                 | <b># of engines</b> | <b>hp</b> | <b>LF</b> | <b>hrs of operation</b> | <b>hp-hr</b> |
|--|---------------------|-----------|-----------|-------------------------|--------------|
| Trk, HWY 8,800GVW 4 x4, 2 axle                   | 1                   | 130       | 0.59      | 26                      | 1994         |
| Trk, HWY 45,000GVW 3 axle                        | 1                   | 230       | 0.59      | 26                      | 3528         |
| Trk, HWY 50,000GVW 3 axle                        | 1                   | 310       | 0.59      | 79                      | 14449        |
| Dump Trk, Highway, 10-13 CY, 35T                 | 1                   | 265       | 0.59      | 26                      | 4065         |
| Trk, HWY 25,000GVW 2 axle                        | 1                   | 210       | 0.59      | 53                      | 6567         |
| Crane, Crawler, Clamshell 2.5 cy, 60T            | 1                   | 263       | 0.59      | 70                      | 10862        |
| Pile Hammer, Driver, Vibratory, 80T              | 1                   | 325       | 0.59      | 70                      | 13423        |
| Pump, Water, Dia, 17,600 GPM                     | 1                   | 8         | 0.43      | 70                      | 241          |
| Brush Chipper, 12" cap., disk type, trailer mtd. | 1                   | 142       | 0.78      | 70                      | 7753         |
| Ldr, F/E, Crwler, 2.6 cy bkt                     | 1                   | 160       | 0.59      | 70                      | 6608         |
| Chainsaw, gas, 36" long.                         | 1                   | 5.7       | 0.70      | 53                      | 211          |
| Hydraulic Excav., crawler, 55,000#, 1.50 cy bkt. | 1                   | 176       | 0.59      | 53                      | 5504         |
| Dump Trk, Highway, 16-20 CY                      | 1                   | 400       | 0.59      | 318                     | 75048        |
| Crane, Crawler, Clamshell 0.5 cy, 17T            | 1                   | 284       | 0.59      | 280                     | 46917        |
| Roller, vibratory, self-propelled, 6T,           | 1                   | 108       | 0.59      | 159                     | 10131        |
| Tractor, Crawler (dozer)                         | 1                   | 80        | 0.59      | 210                     | 9912         |
| Grader, Motor, Articulated                       | 1                   | 135       | 0.59      | 53                      | 4221         |
| Ldr, F/E, Crwler, 1.30 cy bkt                    | 1                   | 90        | 0.59      | 53                      | 2814         |
| Ldr, F/E, Crwler, Wheel, Articulated, 5.5 cy bkt | 1                   | 349       | 0.59      | 53                      | 10913        |

Load Factors taken from Median Life, Annual Activity, and Load Factor Values for Nonroad Engine Emissions Modeling

Report No. NR-005c, revised April 2004, EPA420-P-04-005. Environmental Protection Agency, Office of Transportation and Air Quality

**Table 2. Emission Estimates (NOx)**

Emissions (g) = Power Demand (hp-hr) \* Emission Factor (g/hp-hr)

Emissions (tons) = Emissions (g) \* (1 ton/907200 g)

NOx Emissions Factor for Off-Road Construction Equipment is 6.9 g/hp-hr\*

| <b>Equipment/Engine Category</b>                 | <b>hp-hr</b> | <b>EF<br/>(g/hp-hr)</b> | <b>Emissions<br/>(tons)</b> |
|--|--------------|-------------------------|-----------------------------|
| Trk, HWY 8,800GVW 4 x4, 2 axle                   | 1994         | 6.90                    | 0.02                        |
| Trk, HWY 45,000GVW 3 axle                        | 3528         | 6.90                    | 0.03                        |
| Trk, HWY 50,000GVW 3 axle                        | 14449        | 6.90                    | 0.03                        |
| Dump Trk, Highway, 10-13 CY, 35T                 | 4065         | 6.90                    | 0.05                        |
| Trk, HWY 25,000GVW 2 axle                        | 6567         | 6.90                    | 0.08                        |
| Crane, Crawler, Clamshell 2.5 cy, 60T            | 10862        | 6.90                    | 0.10                        |
| Pile Hammer, Driver, Vibratory, 80T              | 13423        | 6.90                    | 0.00                        |
| Pump, Water, Dia, 17,600 GPM                     | 241          | 6.90                    | 0.06                        |
| Brush Chipper, 12" cap., disk type, trailer mtd. | 7753         | 6.90                    | 0.05                        |
| Ldr, F/E, Crwler, 2.6 cy bkt                     | 6608         | 6.90                    | 0.00                        |
| Chainsaw, gas, 36" long.                         | 211          | 6.90                    | 0.04                        |
| Hydraulic Excav., crawler, 55,000#, 1.50 cy bkt. | 5504         | 6.90                    | 0.57                        |
| Dump Trk, Highway, 16-20 CY                      | 75048        | 6.90                    | 0.36                        |
| Crane, Crawler, Clamshell 0.5 cy, 17T            | 46917        | 6.90                    | 0.08                        |
| Roller, vibratory, self-propelled, 6T,           | 10131        | 6.90                    | 0.08                        |
| Tractor, Crawler (dozer)                         | 9912         | 6.90                    | 0.03                        |
| Grader, Motor, Articulated                       | 4221         | 6.90                    | 0.02                        |
| Ldr, F/E, Crwler, 1.30 cy bkt                    | 2814         | 6.90                    | 0.08                        |
| Ldr, F/E, Crwler, Wheel, Articulated, 5.5 cy bkt | 10913        | 6.90                    | 0.00                        |

**Total NOx Project Emissions (tons) = 1.68**

\*Emission Factor taken from Exhaust and Crankcase Emission Factors for Nonroad Engine Modeling-Compression-Ignition  
Report No. NR-009c, Revised April 2004, Assessment and Standards Division EPA, Office of Transportation and Air Quality

**Table 3. Emission Estimates (VOC)**

Emissions (g) = Power Demand (hp-hr) \* Emission Factor (g/hp-hr)

Emissions (tons) = Emissions (g) \* (1 ton/907200 g)

VOC Emissions Factor for Off-Road Construction Equipment is 1.0 g/hp-hr

| <b>Equipment/Engine Category</b>                 | <b>hp-hr</b> | <b>EF<br/>(g/hp-hr)</b> | <b>Emissions<br/>(tons)</b> |
|--|--------------|-------------------------|-----------------------------|
| Trk, HWY 8,800GVW 4 x4, 2 axle                   | 1994         | 1.00                    | 0.00                        |
| Trk, HWY 45,000GVW 3 axle                        | 3528         | 1.00                    | 0.02                        |
| Trk, HWY 50,000GVW 3 axle                        | 14449        | 1.00                    | 0.00                        |
| Dump Trk, Highway, 10-13 CY, 35T                 | 4065         | 1.00                    | 0.01                        |
| Trk, HWY 25,000GVW 2 axle                        | 6567         | 1.00                    | 0.01                        |
| Crane, Crawler, Clamshell 2.5 cy, 60T            | 10862        | 1.00                    | 0.01                        |
| Pile Hammer, Driver, Vibratory, 80T              | 13423        | 1.00                    | 0.00                        |
| Pump, Water, Dia, 17,600 GPM                     | 241          | 1.00                    | 0.01                        |
| Brush Chipper, 12" cap., disk type, trailer mtd. | 7753         | 1.00                    | 0.01                        |
| Ldr, F/E, Crwler, 2.6 cy bkt                     | 6608         | 1.00                    | 0.00                        |
| Chainsaw, gas, 36" long.                         | 211          | 1.00                    | 0.01                        |
| Hydraulic Excav., crawler, 55,000#, 1.50 cy bkt. | 5504         | 1.00                    | 0.08                        |
| Dump Trk, Highway, 16-20 CY                      | 75048        | 1.00                    | 0.05                        |
| Crane, Crawler, Clamshell 0.5 cy, 17T            | 46917        | 1.00                    | 0.01                        |
| Roller, vibratory, self-propelled, 6T,           | 10131        | 1.00                    | 0.01                        |
| Tractor, Crawler (dozer)                         | 9912         | 1.00                    | 0.00                        |
| Grader, Motor, Articulated                       | 4221         | 1.00                    | 0.00                        |
| Ldr, F/E, Crwler, 1.30 cy bkt                    | 2814         | 1.00                    | 0.01                        |
| Ldr, F/E, Crwler, Wheel, Articulated, 5.5 cy bkt | 10913        | 1.00                    | 0.00                        |

**Total VOC Project Emissions (tons) = 0.26**

\*Emission Factor taken from Exhaust and Crankcase Emission Factors for Nonroad Engine Modeling-Compression-Ignition  
Report No. NR-009c, Revised April 2004, Assessment and Standards Division EPA, Office of Transportation and Air Quality

**Table 4. Emission Estimates (PM)**

Emissions (g) = Power Demand (hp-hr) \* Emission Factor (g/hp-hr)

Emissions (tons) = Emissions (g) \* (1 ton/907200 g)

PM Emissions Factor for Off-Road Construction Equipment is 0.4 g/hp-hr\*

| <b>Equipment/Engine Category</b>                 | <b>hp-hr</b> | <b>EF<br/>(g/hp-hr)</b> | <b>Emissions<br/>(tons)</b> |
|--|--------------|-------------------------|-----------------------------|
| Trk, HWY 8,800GVW 4 x4, 2 axle                   | 1994         | 0.40                    | 0.00                        |
| Trk, HWY 45,000GVW 3 axle                        | 3528         | 0.40                    | 0.00                        |
| Trk, HWY 50,000GVW 3 axle                        | 14449        | 0.40                    | 0.01                        |
| Dump Trk, Highway, 10-13 CY, 35T                 | 4065         | 0.40                    | 0.00                        |
| Trk, HWY 25,000GVW 2 axle                        | 6567         | 0.40                    | 0.00                        |
| Crane, Crawler, Clamshell 2.5 cy, 60T            | 10862        | 0.40                    | 0.00                        |
| Pile Hammer, Driver, Vibratory, 80T              | 13423        | 0.40                    | 0.01                        |
| Pump, Water, Dia, 17,600 GPM                     | 241          | 0.40                    | 0.00                        |
| Brush Chipper, 12" cap., disk type, trailer mtd. | 7753         | 0.40                    | 0.00                        |
| Ldr, F/E, Crwler, 2.6 cy bkt                     | 6608         | 0.40                    | 0.00                        |
| Chainsaw, gas, 36" long.                         | 211          | 0.40                    | 0.00                        |
| Hydraulic Excav., crawler, 55,000#, 1.50 cy bkt. | 5504         | 0.40                    | 0.00                        |
| Dump Trk, Highway, 16-20 CY                      | 75048        | 0.40                    | 0.03                        |
| Crane, Crawler, Clamshell 0.5 cy, 17T            | 46917        | 0.40                    | 0.02                        |
| Roller, vibratory, self-propelled, 6T,           | 10131        | 0.40                    | 0.00                        |
| Tractor, Crawler (dozer)                         | 9912         | 0.40                    | 0.00                        |
| Grader, Motor, Articulated                       | 4221         | 0.40                    | 0.00                        |
| Ldr, F/E, Crwler, 1.30 cy bkt                    | 2814         | 0.40                    | 0.00                        |
| Ldr, F/E, Crwler, Wheel, Articulated, 5.5 cy bkt | 10913        | 0.40                    | 0.00                        |

**Total PM Project Emissions (tons) = 0.10**

\*Emission Factor taken from Exhaust and Crankcase Emission Factors for Nonroad Engine Modeling-Compression-Ignition Report No. NR-009c, Revised April 2004, Assessment and Standards Division EPA, Office of Transportation and Air Quality

### **Table 5. Pollutant Emissions from Employee Vehicles**

#### **Assumptions:**

- Average trip distance (1 way) is 25 miles.
- Average NOx vehicle emission factor is 1.4 g/mile.
- Average VOC vehicle emission factor is 2.8 g/mile.
- Work crew comprised of 12 people
- Every member of the work crew drives their own vehicle.
- Project construction period is 4 months.
- Project construction occurs 5 days per week.
- There are 3 holidays in the work period.
- There are 4 weather days (no work).

Actual days = 120 days - 32 weekend days off - 2 holidays off - 4 weather days off

Actual work days = 83 days

NOx Calculation: 12 workers \* 2 trips/work day \* 83 work days \* 25 miles/trip \* 1.4 g of NOx/mile\* (1 ton/907200 g)

Total NOx resulting from employee vehicles = 0.08 tons.

VOC Calculation: 12 workers \* 2 trips/work day \* 83 work days \* 25 miles/trip \* 2.8 g of VOC/mile\* (1 ton/907200 g)

Total VOC resulting from employee vehicles = 0.15 tons.

Pollutant emissions associated with employee vehicles derived from:

Emission Facts: Average Annual Emissions and Fuel Consumption for Passenger Cars and Light Trucks, EPA420-F-00-013, April 2000.

**Total (construction and employees) NOx Project Emissions (tons) = 1.76**

**Total (construction and employees) VOC Project Emissions (tons) = 0.41**

**Total PM Project Emissions (tons) = 0.10**

## **Appendix D**

### **Public / Agency Comments to the draft EA and Corps Responses**



# Stockbridge-Munsee Tribal Historic Preservation Office

Sherry White - Tribal Historic Preservation Officer  
W13447 Camp 14 Road  
P.O. Box 70  
Bowler, WI 54416

Date 02-11-14  
Project Number Draft for comment  
TCNS-Number Enviro. Assess. North Coventry Streambank Stab.  
Company Name Dept of the Army

We have received your letter for the above listed project. Before we can process the request we need more information. The additional items needed are checked below.

## Additional Information Required:

- Site visit by Tribal Historic Preservation Officer
- Archeological survey, Phase 1
- Colored maps
- Pictures of the site
- Any reports the State Historic Preservation Office may have
- Review fee of \$300.00 must be included with letter
- Has site been previously disturbed, please explain what the use was and when it was disturbed

## After reviewing your letter:

- We are in the process of gathering more information on this site and will respond to your project request once all information has been gathered.
- This project has the potential to affect a Mohican cultural site, please contact us
- This project is not within Mohican area of interest
- This project is within Mohican territory, but we are not aware of any cultural site within the project area.

Additional  
comments \_\_\_\_\_  
\_\_\_\_\_  
\_\_\_\_\_  
\_\_\_\_\_

Should this project inadvertently uncover a Native American site, we require you to halt all construction and notify the Stockbridge-Munsee Tribe immediately.

Please do not resubmit projects for changes that are not ground disturbance

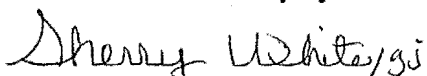
  
Sherry White, Tribal Historic Preservation Officer

USACE Response: No Response Necessary



# Pennsylvania Fish & Boat Commission

**Division of Environmental Services**  
Natural Diversity Section  
450 Robinson Lane  
Bellefonte, PA 16823  
814-359-5237

February 28, 2014

**IN REPLY REFER TO**

SIR# 42161

DEPARTMENT OF THE ARMY  
Mark Eberle  
100 Penn Square East  
Philadelphia, Pennsylvania 19107

**RE: Species Impact Review (SIR) – Rare, Candidate, Threatened and Endangered Species  
North Coventry Township Streambank Project  
CHESTER County: North Coventry Township**

Dear Mark Eberle:

This responds to your inquiry about a Pennsylvania Natural Diversity Inventory (PNDI) Internet Database search “potential conflict” or a threatened and endangered species impact review. These projects are screened for potential conflicts with rare, candidate, threatened or endangered species under Pennsylvania Fish & Boat Commission jurisdiction (fish, reptiles, amphibians, aquatic invertebrates only) using the Pennsylvania Natural Diversity Inventory (PNDI) database and our own files. These species of special concern are listed under the Endangered Species Act of 1973, the Wild Resource Conservation Act, and the Pennsylvania Fish & Boat Code (Chapter 75), or the Wildlife Code.

According to this submission and our records there have been no changes in the project or on-site biological information; therefore, the Commission’s comments regarding potential impacts to rare, candidate, threatened, or endangered species under our jurisdiction, as detailed in our letter of May 10, 2012 for SIR# 38572, remain unchanged.

This response represents the most up-to-date summary of the PNDI data and our files and is valid for two (2) years from the date of this letter. An absence of recorded species information does not necessarily imply species absence. Our data files and the PNDI system are continuously being updated with species occurrence information. Should project plans change or additional information on listed or proposed species become available, this determination may be reconsidered, and consultation shall be re-initiated.

**Our Mission:**

[www.fish.state.pa.us](http://www.fish.state.pa.us)

*To protect, conserve and enhance the Commonwealth's aquatic resources and provide fishing and boating opportunities.*

**If you have any questions regarding this review, please contact Kathy Gipe at 814-359-5186 and refer to the SIR # 42161.** Thank you for your cooperation and attention to this important matter of species conservation and habitat protection.

Sincerely,

A handwritten signature in black ink that reads "Christopher A. Urban". The signature is written in a cursive style with a large initial "C".

Christopher A. Urban, Chief  
Natural Diversity Section

CAU/KDG/dn

USACE Response: No Response Necessary

**Federal Interagency Comment Form**

**PROJECT:** U.S. Corps of Engineers  
North Coventry Township  
Streambank Stabilization Project  
Section 14-Emergency Streambank Stabilization  
Chester County, PA

**APPL. NUMBER:** CENAP-PL-E-14-01

**Commenting Agency:** NOAA Fisheries

**Project Manager:** Mark Eberle

**Waterway** Schuylkill River

**Activity** Streambank stabilization project.

**ESSENTIAL FISH HABITAT (EFH)**

No essential fish habitat has been designated in the project area.

**ESSENTIAL FISH HABITAT CONSERVATION RECOMMENDATIONS** (Note: EFH CRs require a response from the federal action agency within 30 days of receipt or 10 days before a permit is issued if CRs are not included as a special condition of the permit)

None necessary.

**FISH AND WILDLIFE COORDINATION ACT COMMENTS**

American shad has been reported downstream and shad larvae have been released above of the project area. Because it is possible that they could be present in the vicinity of the project, we recommend avoiding in water work from April 1 to June 30 to the extent possible.

**ENDANGERED SPECIES**

No threatened or endangered species under the jurisdiction of the NMFS are known to occur in the project area as per NMFS's April 14, 2012 letter.

SIGNATURE: Karen Greene DATE: 2/25/2014

USACE Response: Concur. All in water construction work will occur within the recommended environmental window of July 1 - March 31st.



UNITED STATES ENVIRONMENTAL PROTECTION AGENCY  
REGION III  
1650 Arch Street  
Philadelphia, Pennsylvania 19103-2029

MAR 04 2014

Mark Eberle  
Department of the Army  
Philadelphia District, Corps of Engineers  
Environmental Resources Branch  
Wanamaker Building, 100 Penn Square East  
Philadelphia, Pennsylvania 19107

RE: Draft Environmental Assessment for the Schuylkill River Stream bank Stabilization Project, North Coventry Township, Chester County, Pennsylvania

Dear Mr. Eberle:

The U.S. Environmental Protection Agency has received and reviewed the Environmental Assessment (EA) for the Schuylkill River Stream bank Stabilization Project, located in North Coventry Township, Chester County, Pennsylvania. EPA has reviewed this project in conjunction with our responsibilities under the National Environmental Policy Act (NEPA), Section 309 of the Clean Air Act, and the Council of Environmental Quality regulations implementing NEPA (40 CFR 1500-1508). The project involves stabilizing the west bank of the Schuylkill River along River Road using Longitudinal Peak Stone Toe Protection (LPSTP) between State Highway 100 overpass and Hanover Street. The purpose and need of the project is for roadway protection due to stream bank erosion.

1. The EA considers several alternatives including the no action alternative. Action alternatives include making the existing road one way, relocating the existing road, armoring the stream bank using rip rap, and armoring/bioengineering combination on the stream bank. The armoring/bioengineering combination of the stream bank includes the LPSTP, which is the preferred alternative. Although the EA includes descriptions of these alternatives, only the no action and preferred alternative were evaluated in detail. For future studies, EPA would recommend that additional alternatives be retained for detailed study beyond the no action and preferred action alternative. This approach provides a more robust analysis of multiple alternatives which appear to meet the purpose and need of the project.

2. Limited information regarding potential Environmental Justice (EJ) communities and impacts were included in the EA. The EJ analysis should identify communities or populations of concern, and include meaningful and timely community involvement, public outreach and access to information. The analysis should include demographic and Census data, without this information it should not be assumed that no populations of concern are present and that no impacts will occur. We suggest that a map be provided showing the study area, without this it cannot be determined which areas were included in the analysis or which areas the statistics relate to, as well as more detailed and complete demographic data. Please clarify what areas,

block groups or Census Tracts represent the minority information included. The analysis would also be greatly improved by providing related County and State data for minority and low-income populations. It would also be helpful to describe the community outreach performed for the proposed actions. Please continue to avoid, minimize and mitigate for potential community impacts. EPA suggests improving EJ analysis and documentation in future NEPA studies.

3. EPA strongly encourages a thorough cumulative effects analysis for past, present and reasonably foreseeable projects. The EA could be improved by defining the geographic and temporal limits of the study. We suggest a broader approach to the study, making it more meaningful and comprehensive. The cumulative effects analysis is important to the EA as it may aid in the identification of resources that are likely to be affected by multiple projects, and sensitive resources that could require additional avoidance, minimization and mitigation measures.

4. As the project moves forward into greater levels of design, please continue to consider opportunities to avoid and minimize adverse impacts to natural resources, particularly streams, wetlands and floodplains. Be sure to consider alternative construction techniques which may further reduce impacts to the Schuylkill River, and whether improvements to the riparian buffer can be made. The document notes that there is a break between project phases where no work is proposed. EPA suggests evaluating whether there are any bank characteristics from this stable portion which may be incorporated or replicated into the proposed design. Additionally, please consider whether the proposed stabilization will alter the river thalweg/hydrology which may cause unanticipated impacts to commercial fishing, plankton, fish and shellfish, wildlife or special aquatic sites. EPA suggests that a Floodplain Action Plan may be beneficial for this project, which could include plans for equipment, materials or fuel storage outside the floodplain, and stabilization measures or work plan in advance of storm events.

Thank you for coordinating with EPA on this project. Please continue providing copies of Philadelphia District's NEPA documentation to EPA, we look forward to working with the Corps on future projects. If you have any questions or would like to discuss our comments, the staff contact for this project is Ms. Alaina McCurdy; she can be reached at 215-814-2741.

Sincerely,



Barbara Rudnick  
NEPA Team Leader  
Office of Environmental Programs

USACE Response:

1. Not concur. The USACE is transitioning to a new policy of SMART Planning with the premise of reducing the time and cost of project studies and projects for the American public. Included in our new paradigm is to provide a NEPA review that is commensurate with the complexity of the study or project. We feel this EA, including the alternative analysis, is sufficient in detail and analysis to reflect the complexity of a small streambank stabilization project.
2. Not concur. As stated previous, the USACE is trying to streamline studies and projects to benefit the American public. Since this is a streambank stabilization project, which is not having a negative impact on any local community; we feel that an in-depth Environmental Justice analysis would be excessive for this small scale project.
3. Not concur. Since this is a small scale streambank stabilization project, which is only having a temporary minor impact on the fish and wildlife resources; we feel that an in-depth cumulative impact analysis would be excessive for this small scale project. In locations where we are proposing to install our streambank project, the riparian area should actually increase in size. Furthermore, with the addition of the bioengineering and planting of native species, the long term cumulative impacts of this project should be positive in nature.
4. Concur. As we move further into the planning process for this project, we will continue to consider ways to reduce the impacts of our selected alternative. This will include consideration of alternative construction techniques, best management practices during project construction, and planning for storm events on the construction site. In addition, the project team will discuss the existing bank characteristics of the stable portion of the streambank in this area, to see if any of these features would be applicable to our project design. Furthermore, we don't believe that our stabilization project will have an impact on the river's thalweg or lead to any unanticipated consequences to local fish and wildlife resources.

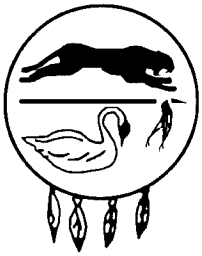

# EASTERN SHAWNEE TRIBE OF OKLAHOMA

12755 S. 705 Road, Wyandotte, OK 74370  
Bluejacket Building (918) 666-2435, Fax: (918) 666-2186

RECEIVED MAR 19 2014

March 12, 2014

Peter Blum, P.E.  
Philadelphia District, Corps of Engineers  
Wanamaker Building, 100 Penn Square East  
Philadelphia, Pennsylvania 19107-3390

**RE: Streambank Stabilization Project**

Dear Mr. Blum,

We are in receipt of your letter dated February 7, 2014 regarding the Streambank Stabilization project

We are not currently aware of existing documentation directly linking Shawnee religious, cultural, or historic sites to Chester County, Pennsylvania.

Should any Native American cultural items falling under the Native American Graves Protection and Repatriation Act (NAGPRA) be discovered during this or any construction project the ESTO requests to be notified.

Best regards,

Robin Dushane  
Tribal Historic Preservation Officer

USACE Response: No Response Necessary





# pennsylvania

DEPARTMENT OF ENVIRONMENTAL PROTECTION

BUREAU OF AIR QUALITY

April 7, 2014

Minas M. Arabatzis  
Chief, Planning Division  
U.S. Army Corps of Engineers  
Philadelphia District  
Wanamaker Building  
100 Penn Square East  
Philadelphia, PA 19107-3390

Re: Preliminary Comments on the February 2014 Draft Environmental Assessment for the North Coventry Streambank Stabilization Project

Dear Mr. Arabatzis:

The Pennsylvania Department of Environmental Protection (DEP) greatly appreciates the opportunity to comment on the United States Army Corps of Engineers (Corps) General Conformity Analysis for the North Coventry Streambank Stabilization Project in Chester County, Pennsylvania.

The General Conformity Analysis provided by the Corps demonstrates that the Streambank Stabilization Project in North Coventry Township is below de minimis threshold levels for General Conformity. To this end, DEP submits this approval in accordance with Section 176(c) of the federal Clean Air Act, 42 U.S.C. § 7506(c), and implementing regulations in 40 CFR Part 93, Subpart B (relating to determining conformity of general federal actions to state or federal implementation plans). The federal Subpart B requirements are also adopted and incorporated by reference in 25 *Pa. Code* §§ 127.801 and 127.802 (relating to general conformity).

Should you have questions or need additional information, please contact me by e-mail at [jeepps@state.pa.us](mailto:jeepps@state.pa.us) or by telephone at 717.787.9702. You may also contact Chris Trostle by e-mail at [dtrostle@pa.gov](mailto:dtrostle@pa.gov) or by telephone at 717.772.3926.

Sincerely,

Joyce E. Epps  
Director

USACE Response: No Response Necessary

---

Rachel Carson State Office Building | P.O. Box 8468 | Harrisburg, PA 17105-8468

717.787.9702 | Fax 717.772.2303

Printed on Recycled Paper

[www.depweb.state.pa.us](http://www.depweb.state.pa.us)