



Overview of Doing Business with Space and Naval Warfare Systems Command (SPAWAR)



SPAWAR Office of Small Business
Programs (OSBP)



Agenda

- ▼ **Who is SPAWAR and what is our role?**
 - Where we are and what we buy
- ▼ **Doing Business with SPAWAR**
 - SPAWAR OSBP mission and vision
 - Small business targets and accomplishments
 - Small Business Office public webpage
 - e-Commerce Central website
- ▼ **Resources and POCs**



SPAWAR...the Navy's Information Dominance Systems Command



SPAWAR's Role

- ▼ Navy's Information Dominance Systems Command
- ▼ Provide advanced communications and information capabilities to Navy, joint and coalition forces
- ▼ More than 8,500 employees deployed globally and near the fleet



Information Dominance is the operational advantage gained from fully integrating the Navy's information functions, capabilities and resources to optimize decision making and maximize warfighting effects.

Meeting Current and Future Needs of the Fleet



Consolidating Networks



Research, Engineering
& Development



C4ISR Technology



Cyber Operations



Internet Cafes



Unmanned
Vehicle Systems



Global Presence



Partial display of SPAWAR personnel assignment locations



OSBP Organizational Overview

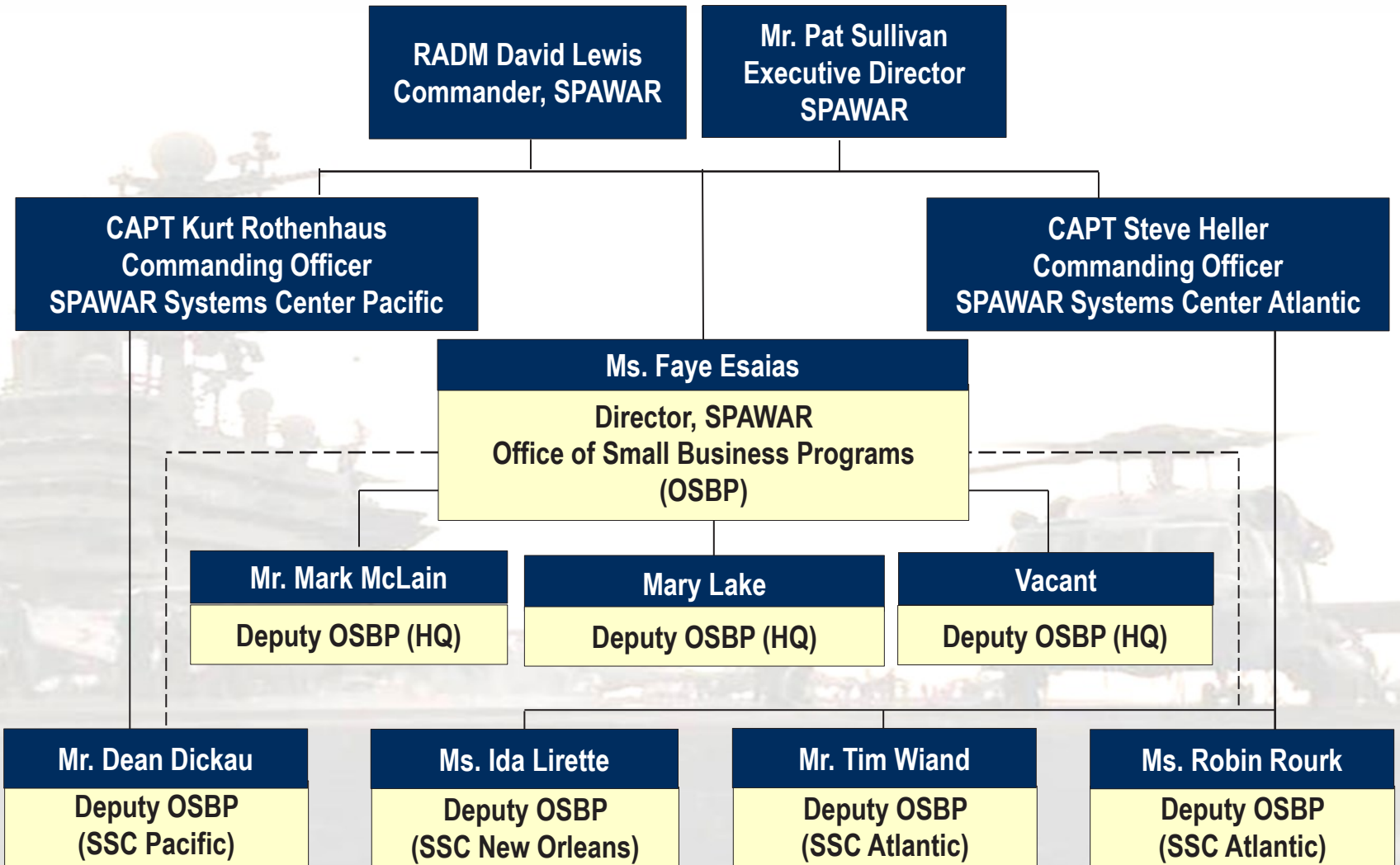



Top 10 NAICS Awarded by Dollars - FY14

NAICS	SB Size Standards in \$M	SB Size Standards in # Employees	Description	Action Obligated
541330	\$38.5	N/A	Engineering Services	\$2,392,587,387
334220	N/A	750	Radio and Television Broadcasting and Wireless Communications Equipment Manufacturing	\$482,642,313
541519	\$27.5	N/A	Other Computer Related Services	\$378,571,649
541512	\$27.5	N/A	Computer Systems Design Services	\$267,065,982
334290	N/A	750	Other Communications Equipment Manufacturing	\$266,674,473
541712	N/A	500	Research and Development in the Physical, Engineering, and Life Sciences (except Biotechnology)	\$210,237,815
517410	\$32.5	N/A	Satellite Telecommunications	\$180,977,178
517110	N/A	1,500	Wired Telecommunications Carriers	\$164,082,008
541511	\$27.5	N/A	Custom Computer Programming Services	\$162,576,160
511210	\$38.5	N/A	Software Publishers	\$136,888,482



Top 10 Small Business NAICS Awarded by Dollars - FY14

NAICS	SB Size Standards in \$M	SB Size Standards in # Employees	Description	Action Obligated
541330	\$38.5	N/A	Engineering Services	\$678,097,339
334220	N/A	750	Radio and Television Broadcasting and Wireless Communications Equipment Manufacturing	\$172,864,819
335999	N/A	500	All Other Miscellaneous Electrical Equipment and Component Manufacturing	\$79,349,708
541519	\$27.5	N/A	Other Computer Related Services	\$58,492,410
541712	N/A	500	Research and Development in the Physical, Engineering, and Life Sciences (except Biotechnology)	\$48,600,665
334210	N/A	1,000	Telephone Apparatus Manufacturing	\$29,059,378
541511	\$27.5	N/A	Custom Computer Programming Services	\$28,964,615
334111	N/A	1,000	Electronic Computer Manufacturing	\$21,085,419
334310	N/A	750	Audio and Video Equipment Manufacturing	\$19,449,257
334290	N/A	750	Other Communications Equipment Manufacturing	\$18,365,869



Code 013 OSBP Mission and Vision

Mission

We are a dynamic advocacy that provides training, advice, guidance, and innovative strategies ensuring quality solutions for SPAWAR acquisition teams while maximizing opportunities for small businesses, as required by the Small Business Act and Federal Acquisition Regulation.

Vision

Code 013 will embrace a culture of shared responsibility that recognizes the critical role of small businesses in advancing our naval capability and the strength of the nation's economy by seeking utilization of qualified small businesses at the earliest stage of acquisition planning.



Small Business Statistics - Side-Side Comparison for FY14 and FY15 – YTD as of 30 September 2015

New SBAM approach used since Dec 2013

FY15

FY14

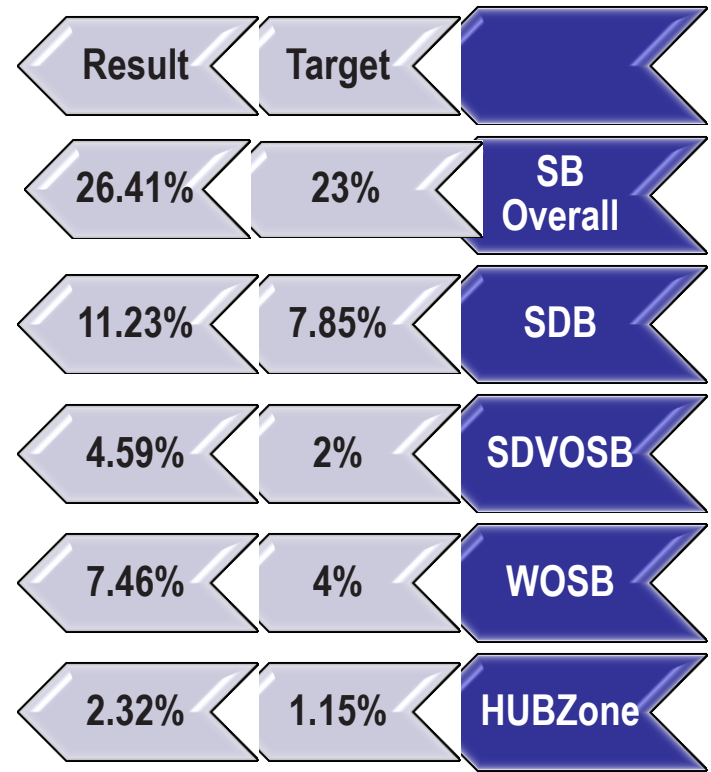
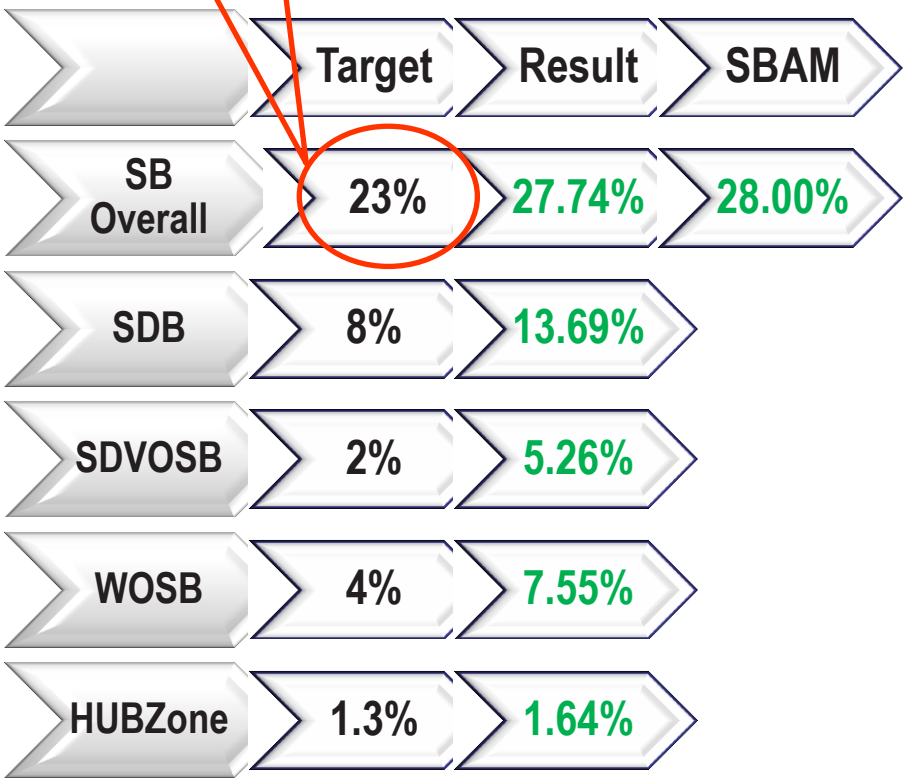



SPAWAR SB Performance Dashboard for FY15 YTD

FY15 SB Dashboard SPAWAR

Data as of: 30 September 2015

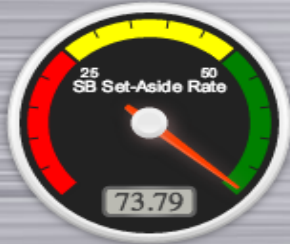
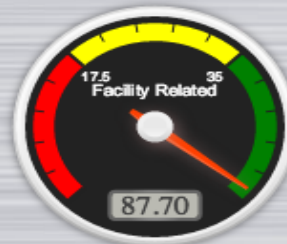
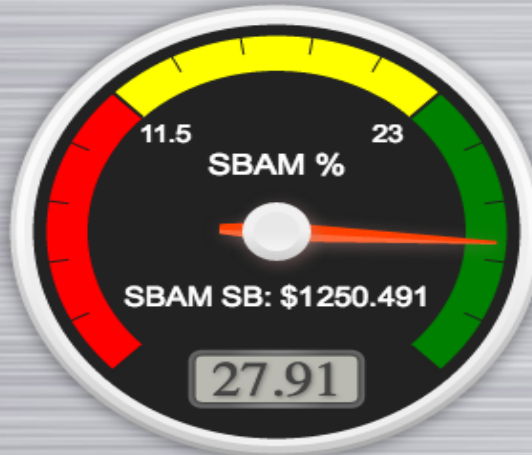
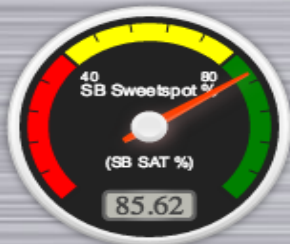

SBAM Spend: 4,480,749,114

Total Spend: 4,524,260,961

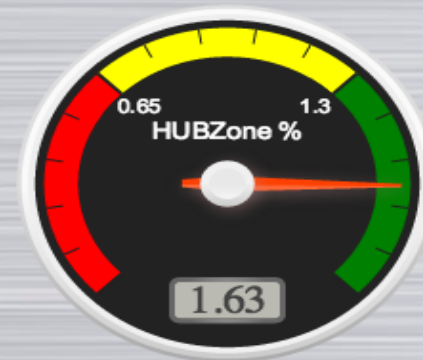
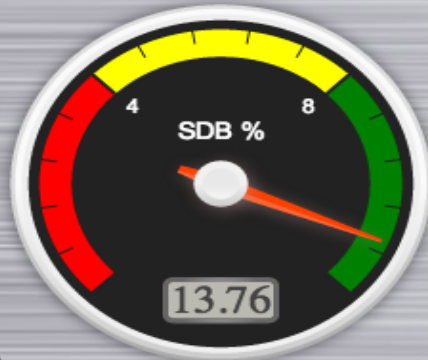

Authority/Policy

▼ Regulations

- Federal Acquisition Regulation (FAR)
- Defense FAR Supplement (DFARS)
- Navy - Marine Corps Acquisition Regulation Supplement (NMCARS)



▼ Policies

- Federal government
- Department of Defense
- Department of Navy
- SPAWAR

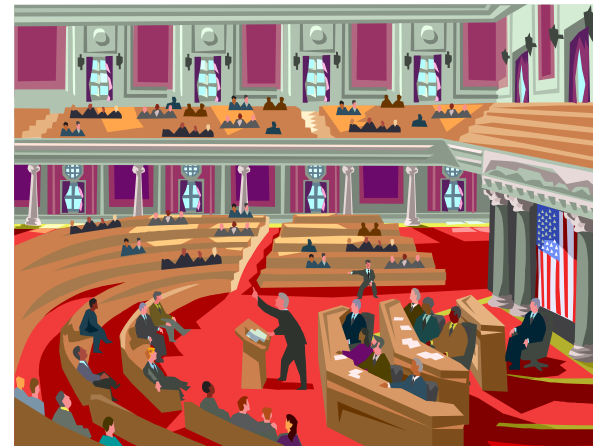

Small Business Considerations

- ▼ SPAWAR policy is to provide maximum practicable opportunity in its acquisitions to small business concerns as both prime contractors and subcontractors
- ▼ Efforts to ensure small business participation in each acquisition above \$10,000 is documented on the DD2579 (Small Business Coordination Record). SAP actions are automatically reserved for small businesses unless justified otherwise. SeaPort-e are approved via the portal.
- ▼ Rule of 2: Need two or more qualified small businesses to the action aside.





How To Identify Opportunities Within DOD

▼ Posting of contract actions:

- Federal Business Opportunities ([FedBizOpps](https://www.fbo.gov)) is a web-based system for posting solicitations and other procurement-related documents to the Internet. FedBizOpps was designated by the Federal Acquisition Regulation as the mandatory "government wide point of entry for the posting government business opportunities greater than \$25,000."

▼ For more information visit:

www.fbo.gov





How To Locate Information on SPAWAR Opportunities

- ▼ On the SPAWAR webpage (www.spawar.navy.mil) click on "For Industry Partners" which will direct you to our e-commerce site. A list of our future opportunities, open solicitations and contract awards is available for SPAWAR Headquarters, SSC Atlantic and SSC Pacific.





SPAWAR e-Commerce Website

e-Commerce **SPAWAR CONTRACTS DIRECTORATE OFFICE**

[Login](#) | [Lost Username/Password?](#) | [Register](#) | [Contact Us](#) | [Credits](#) | [Advanced Search](#) | Solicitation Quick Search: [GO!](#)

Welcome

A Message from our Commander

"As the Navy's C4I experts, we listen to our customers and find the right solutions for their C4I challenges. In response, we emphasize providing information solutions versus just information systems." [Read more](#)

Browser Support

The SPAWAR E-Commerce Central is best viewed with Internet Explorer. In addition, submission of proposals and any other documents through E-CC works best with use of Internet Explorer. The use of other browsers besides Internet Explorer may result in delayed receipt or unsuccessful submission of documents. If using a non-Internet Explorer browser, you may want to begin transmission of electronic documents 2-3 days in advance to ensure timely submission. (This message is not an endorsement for Internet Explorer by the U.S. Navy and SPAWAR)

Recommended Adobe Acrobat and WinZip versions.

Industry Partners: Adobe Acrobat X and WinZip version 17.5 are the current Navy standard packages that are installed on all Navy workstations (as of September 2014). For this reason, SPAWAR strongly recommends using those versions or earlier when creating your electronic proposals. The use of later versions of these applications may cause delays in processing your electronic proposals due to the inability to open the submitted files.

Contact E-Commerce Central (E-CC) Support

Forgot your password? ----> Use the on-line Password Reset.

We have implemented a new feature on the e-Commerce Central website to allow users who have lost their password or username to reset/retrieve it via an automated function without having to contact the SPAWAR Paperless Helpdesk. These Self-Service features are available via the links below or can be found under the i-Services folder of the left navigation section of the site.

[Password Reset](#)
[Retrieve Username](#)

Need assistance with something else? Please contact the SPAWAR Paperless Helpdesk by phone at 858-537-0644 or by email at paperless.spawar@navy.mil. Our help desk hours of operation are:

Mon - Thurs : 7:00am - 4:00pm Pacific
Fri : 7:00am - 3:00pm Pacific

News

UPDATED [SPAWAR Multiple Award Contract \(MAC\) Working Group](#)
[SPAWAR Systems Command: Three Year Acquisition Forecast \(Dtd Nov 17 2014\)](#)
[SSC Atlantic: Advanced Notification PPSM and Current Work in Process \(WIP\)](#)
[SSC Atlantic: Seaport-O Advanced Notifications for MAC Service Procurements](#)
[Other News...](#)

Recently Issued

N65236-14-R-0004	Integrated Voice Network (IVN)
N65236-15-Q-0030	Evaluation of Broadband HPA
N65236-15-Q-0609	Repair and Maintenance
N65236-15-Q-0810	L-3 Antenna Repair
N65236-15-Q-0913	Agile Network Rapid Analysis Toolkit

Closing Soon

N65236-15-Q-5036	Palmetto Cyber Defense Competition
N66001-15-T-6516	Sanor Program
N66001-15-T-8021	MACHINED PARTS
N65236-15-Q-0912	Citrix XenApp 7.6 License and Subscription
N65236-15-Q-8004	FLEX BADGEHOLDER FIPS 201 APPROVED PRODUCT

Space and Naval Warfare Systems Command [Accessibility/Section 508](#) **This is an official Department of the Navy web site. This system is subject to monitoring. Please review the [Privacy Policy](#) and [External Link Notice](#).**

<https://e-commerce.sscno.nmci.navy.mil>



Keys to doing business with SPAWAR E-Commerce Central (E-CC)

▼ <https://e-commerce.sscno.nmci.navy.mil>

SSC ATLANTIC

VIEW by...

- [Special Notices](#)
- [Market Surveys](#)
- [Future Opportunities](#)
- [Open Solicitations](#)
- [Open BAAs](#)
- [Simplified Acquisitions](#)
- [Small Business by Type](#)
- [Under Evaluation](#)
- [Closed BAAs](#)
- [Awarded Contracts](#)
- [Solicitation Number](#)
- [BAAs By Number](#)
- [Posting Date](#)
- [FS Code](#)
- [NAICS Code](#)
- [Acquisition Type](#)

The screenshot shows the SPAWAR E-Commerce Central website. A callout box titled "Read Me First" points to the "Read Me First" link in the navigation menu, listing "Central Contractor Registry" and "D-U-N-S Number". Another callout box titled "Vendors Users Guide" points to the "Vendors Users Guide" link in the navigation menu, listing "Your resource for doing business with SPAWAR". The website header includes "SPAWAR CONTRACTS DIRECTORATE OFFICE" and "Message from our Commander". The main content area features a "Current Server Time" section, a "Need assistance with something else?" section, a "News" section with links to "SSC Atlantic: Seaport-O Advanced Notifications for MAC Service Procurements", "SPAWAR Systems Command: Three Year Acquisition Forecast (Dtd July 2014)", and "SSC Atlantic: Acquisition Forecast for MAC Service Procurements-(6 month forecast)", and a "Recently Issued" section with links to "N66001-14-R-0239" and "N66001-14-T-0238". A "Closing Soon" section is also visible at the bottom right.

Read Me First

- Central Contractor Registry
- D-U-N-S Number

Vendors Users Guide

- Your resource for doing business with SPAWAR



- ▼ NAVSEA Multiple Award Contract (MAC) IDIQ vehicle with CPFF and FFP pricing
- ▼ SeaPort-e – The Navy’s electronic platform for acquiring support services in 22 functional areas
- ▼ Individual task orders competed in one of seven geographic zones
 - No sole source orders
- ▼ 2,421 prime contractors (rolling admissions currently closed)
 - nearly 87% of its contract–holders are small businesses
 - Competitive 8(a) set-asides
- ▼ **SPAWAR vehicle of choice for services**
 - Caps on pass-through costs, labor escalation, and fee/profit
 - Streamlined evaluation process
 - Web portal for electronic commerce: www.seaport.navy.mil/



SBIR and STTR Programs

<http://www.acq.osd.mil/osbp/sbir/index.shtml>



U.S. Department of Defense
SMALL BUSINESS INNOVATION RESEARCH
SMALL BUSINESS TECHNOLOGY TRANSFER



- Home
- About
- for Small Business
- for Government
- Awards
- Contacts

Get Started Now!

Learn how to submit a proposal and receive R&D funding for your innovation ideas that support the Warfighter



DoD SBIR/STTR Awards by State - 2012

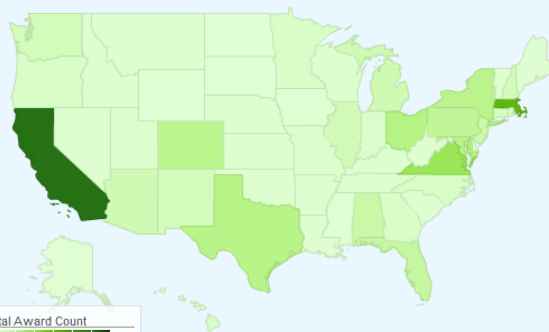

AWARDS	COMMERCIALIZATION	SOCIOECONOMIC
AWARDS BY COMPONENT	COMMERCIALIZATION BY COMPONENT	SOCIOECONOMIC BY COMPONENT

Items of Interest

DEFENSE CONTRACT AUDIT AGENCY (DCAA)
 RESOURCE GUIDE FOR
 SMALL BUSINESS INNOVATION RESEARCH
 SMALL BUSINESS TECHNOLOGY TRANSFER

[CLICK HERE](#)

CONNECT WITH US:



This graphic shows SBIR/STTR program results. Click on the tabs at the bottom of the graphic to view total Awards, Commercialization or Socioeconomic results by State or by Component. Commercialization results are the combined value of sales and additional non-SBIR investments, from either a federal or private entity, which result from, extend, or logically conclude any Phase II project. Click [here](#) to download the data for these graphics for FY 2009–2011.

QUICK LINKS

- Solicitation Schedule
- SITIS—Topic Questions & Answers
- Topics Search



Marketing to the Government: The Basics

▼ Are You Ready to Market to the Government?

- Know how to identify your product/service
- Federal Supply Classification Code (FSC)
- Product Service Code (SVC)
- **EX: D302 ADP Systems Development Services**
- <http://www.usabid.com/resources/tables/pscs/>
- Identify your North American Industry Classification Codes (NAICS)
- **EX: 541512 Computer Systems Design Services**
- <http://www.census.gov/cgi-bin/sssd/naics/naicsrch>
- Determining Size Standard
- **EX: 541512 \$27.5 million average annual receipts preceding three years**
- **NOTE: There is a separate size standard for each NAICS**
- <http://www.sba.gov/content/table-small-business-size-standards>

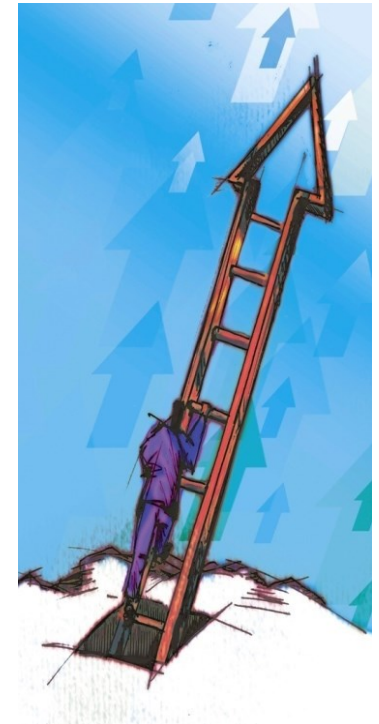

Have a Marketing Strategy!

- ▼ Develop a strategy and a plan:
 - Determine who procures the services and/or commodities you provide
 - Find out as much as you can about their programs/needs (e.g. public websites, networking, etc.)
 - Determine your role and limits (prime, subcontractor, capabilities, etc.)
 - Respond to RFIs and Sources Sought!
 - Identify contract requirements and potential team members
 - Develop strategy for responding to a solicitation





SPAWAR Homepage

www.public.navy.mil/spawar

SPAWAR TEAM SPAWAR **GO** >

SPAWAR ABOUT US CAREERS PRESS PRODUCTS & SERVICES SUPPORT CONTACT US

- Command Biographies
- Competencies
- For Industry Partners...
- For the Fleet...
- Organization Chart
- Site Directory
- Small Business**

Space and Naval Warfare Systems Command

THE NAVY'S INFORMATION DOMINANCE SYSTEMS COMMAND

As the Navy's Information Dominance systems command, SPAWAR develops, delivers and sustains communications and information capabilities for warfighters, keeping them connected anytime, anywhere. With a space support activity, two system centers and through partnerships with three program executive offices, SPAWAR provides the hardware and software needed to execute Navy missions. The team consists of more than 9,500 active duty military and civil service professionals located around the world and close to the fleet to keep SPAWAR at the forefront of research, engineering and acquisition to provide and sustain fleet capabilities. [\(More\)](#)

Follow Us:

Stay Connected!

SYSTEMS CENTER ATLANTIC | SYSTEMS CENTER PACIFIC | PEO C4I | PEO EIS | PEO SPACE SYSTEMS | WASHINGTON LIAISON OFFICE

THIS IS AN OFFICIAL UNITED STATES NAVY WEBSITE

Life is worth living!
1-800-273-TALK
(8255 Option 1)



SPAWAR Office of Small Business Programs

SMALL BUSINESS

SPAWAR has posted an updated three-year acquisition forecast to its public web portal entitled "SPAWAR 3 Year Acquisition Forecast (05-2014)" below. This forecast includes opportunities for SPAWAR Headquarters, SPAWAR System Centers Atlantic and Pacific. The forecast is informational only and does not constitute an offer or commitment by the Navy to fund, in whole or part, the opportunities herein. Vendors shall not contact any contracting or technical personnel regarding this information and all inquires shall be submitted via email to SPAWARSBO@navy.mil

The Small Business program is a dynamic advocacy that provides training, advice and guidance to ensure quality solutions for Navy and Marine Corps acquisitions and maximizes contracting opportunities to small businesses.

SPAWAR Headquarters (San Diego)

Phone: (619) 524-7701

Email: spawarsbo@navy.mil

Fax: (619) 221-5521

Faye Esaias

Director, Small Business Program

Email: faye.esaias@navy.mil

Robert "Zack" Zaccaria

Deputy for Small Business

Email: robert.zaccaria@navy.mil

Mark McLain

Deputy for Small Business

Email: mark.mclain@navy.mil

Aubrey Lavitoria

Deputy for Small Business

Email: aubrey.lavitoria@navy.mil

SPAWAR Systems Center Pacific

Dean Dickau

Deputy for Small Business

Phone: (619) 553-4327

Email: dean.dickau@navy.mil

SPAWAR Systems Center Atlantic: Charleston

Robin Rourk

Deputy for Small Business

Phone: (843) 218-5115

DSN: 588-5115

Fax: (843) 218-5912

Email: robin.rourk@navy.mil

Timothy Wiand

Deputy for Small Business

Phone: (843) 218-5167

DSN: 588-5167

Fax: (843) 218-5912

Email: timothy.wiand@navy.mil

Click any of the items below for more details:

-  SPAWAR 3 Year Acquisition Forecast (11.17.14)
-  SPAWAR Social Media Directory
-  Visitor Information
-  RDA Small Business Memo
-  FY13 SPAWAR OSBP Targets
-  Information Booklet
-  Navy Gold Coast Information
-  Doing Business with SPAWAR
-  Basic Subcontracting Info
-  DoN Office of Small Business Programs
-  DoN Rapid Innovation Fund BAA
-  DoN Mentor-Protege Guidebook For Industry and Acquisition Professionals
-  Visit DoD Mentor-Protege Resources page for a list of templates





SPAWAR OSBP Resources and Contact Information

- ▼ Ms. Faye Esaias, Director for Small Business Programs
 - Phone: (619) 524-7701 or email: faye.esaias@navy.mil
- ▼ Mr. Mark McLain, Deputy for Small Business
 - Phone: (619) 524-7701 or email mark.mclain@navy.mil
- ▼ Ms. Mary Lake, Deputy for Small Business
 - Phone: (619) 524-7701 or email mary.lake@navy.mil
- ▼ Mr. Dean Dickau, Deputy for Small Business for SSC Pacific
 - Phone: (619) 553-4327 or email dean.dickau@navy.mil
- ▼ Ms. Robin Rourk, Deputy for Small Business for SSC Atlantic
 - Phone: (843) 218-5284 or email: robin.rourk@navy.mil
- ▼ Mr. Timothy Wiand, Deputy for Small Business for SSC Atlantic
 - Phone: (843) 218-5167 or email: timothy.wiand@navy.mil
- ▼ Ms. Ida Lirette, Deputy for Small Business for SSC New Orleans
 - Phone: (504) 697-5599 or email: ida.lirette@navy.mil



DoN Office of Small Business Programs

<http://www.donhq.navy.mil/OSBP/>

This is an official U.S. Navy web site

The Department of the Navy Office of Small Business Programs

[HOME](#) | [ABOUT NAVY OSBP](#) | [SMALL BUSINESS PROGRAMS](#) | [GENERAL INFO](#) | [CONFERENCES](#) | [RELATED LINKS](#) | [CONTACT INFO](#)

NAVY & MARINE CORPS BUYING COMMANDS

- Headquarters, U.S. Marine Corps
- Marine Corps Systems Command
- Military Sealift Command
- Naval Air Systems Command
- Naval Facilities Engineering Command
- Naval Sea Systems Command
- Naval Supply Systems Command
- Office of Naval Research
- Space and Naval Warfare Systems Command
- Strategic Systems Programs

SMALL BUSINESS POLICY & GUIDANCE

- Conferences

FAQ'S

→ Frequently Asked Questions

Seán Crean (OSBP Director)
presents
Robert Smith (NAVAIR) with
2012 Oreta B Stinson
Small Business Advocate Award

SECNAV Green Initiatives Portal

Find your Specialist

Click below to find your specialist

<p>USMC MSC NAVAIR NAVFAC NAVICP</p>	<p>NAVSEA NAVSUP ONR SPAWAR SSP</p>
---	--

NAVY

HIRING HEROES CAREER FAIR

JOB OPPORTUNITIES FOR WOUNDED WARRIORS, VETERANS AND THEIR SPOUSES

Department of the Navy's 4th Annual
Wounded Warrior Hiring and Support Conference

October 16 - 17, 2013 / Raleigh, NC

"Hiring our Nation's Heroes"

Career Fair - October 17, 2013

Hilton North Raleigh/Midtown
3415 Wake Forest Road
Raleigh, NC

10:00 a.m. to 3:00 p.m.

Come network with employers from the Department of Defense, other federal agencies and private sector firms with positions available for wounded, ill, injured and transitioning armed services members, their spouses and primary caregivers. For more information, please contact: Mr. Neil Wiley, Defense Civilian Personnel Advisory Service, 575-975-2534 or Neil.Wiley@dcpas.mil

Sponsored by: The Department of Defense/DCPAS and the Department of the Navy

Plot Your Course into the Future
Navy Long Range Forecasts

HOME | ABOUT NAVY OSBP | SMALL BUSINESS PROGRAMS | GENERAL INFO | CONFERENCES | RELATED LINKS | CONTACT | U.S. NAVY | NAVY RECRUITING | MARINES RECRUITING

NO FEAR ACT | PRIVACY & SECURITY | FREEDOM OF INFORMATION ACT(FOIA) | SUICIDE PREVENTION LIFELINE | IMMEDIATE SUPERIOR IN COMMAND | ASN RD&A | ACCESSIBILITY/SECTION 508

DEPARTMENT OF THE NAVY, OFFICE OF SMALL BUSINESS PROGRAMS
720 KENNON AVENUE, SE, BUILDING 36, ROOM 207, WASHINGTON, DC 20374-5015 TELEPHONE: 202-685-6485 FAX: 202-685-6865 E-MAIL: OSBP.INFO@NAVY.MIL

COPYRIGHT © 2012 DEPARTMENT OF NAVY SMALL BUSINESS PROGRAMS ALL RIGHTS RESERVED