

CECW-ED Engineer Manual 1110-2-2701	Department of the Army U.S. Army Corps of Engineers Washington, DC 20314-1000	EM 1110-2-2701 30 November 1997
	Engineering and Design VERTICAL LIFT GATES	
	Distribution Restriction Statement Approved for public release; distribution is unlimited.	

**DEPARTMENT OF THE ARMY
U.S. Army Corps of Engineers
Washington, DC 20314-1000**

EM 1110-2-2701

CECW-ED

Manual
No. 1110-2-2701

30 November 1997

**Engineering and Design
VERTICAL LIFT GATES**

- 1. Purpose.** The purpose of this manual is to provide guidance in the structural design of vertical lift gates.
- 2. Applicability.** This manual applies to all USACE Commands having responsibility for design of civil works projects.
- 3. Discussion.** Several types of vertical lift gates are used in a variety of hydraulic structures, including spillways, low-level inlets/outlets, powerhouses, and navigation locks. In recent years, there have been considerable problems with the performance of vertical lift gates. The majority of these problems have occurred as result of fatigue, causing fracture in main structural framing members of the gate. New criteria address methods to reduce fatigue and fracture through design and construction techniques. Research has proven that the serviceability of the gate can be improved by using proper material selection and fabrication techniques. These fabrication techniques include the use of proper joint detailing and welding procedures. Proper material selection and material compatibilities are essential parts of providing a long service life of the structure.
- 4. Distribution Statement.** Approved for public release, distribution is unlimited.

FOR THE COMMANDER:



OTIS WILLIAMS
Colonel, Corps of Engineers
Chief of Staff

CECW-ED

Manual
No. 1110-2-2701

30 November 1997

**Engineering and Design
VERTICAL LIFT GATES**

Table of Contents

Subject	Paragraph	Page	Subject	Paragraph	Page
Chapter 1					
Introduction					
Purpose	1-1	1-1	Weldments	4-9	4-5
Scope	1-2	1-1	Design Details	4-10	4-5
Applicability	1-3	1-1	Chapter 5		
References	1-4	1-1	Outlet Gates		
Background	1-5	1-1	General	5-1	5-1
Chapter 2			Framing Systems	5-2	5-1
Description and Application			Load Types	5-3	5-1
General	2-1	2-1	Load and Resistance Factor Design	5-4	5-2
Gate Types and Applications	2-2	2-1	Commentary on Loads and Load Factors ..	5-5	5-2
Types of End Supports	2-3	2-2	Serviceability Requirements	5-6	5-3
Advantages/Disadvantages	2-4	2-3	Fatigue and Fracture Control	5-7	5-3
Chapter 3			Material Selection	5-8	5-3
Navigation Lock Lift Gates			Weldments	5-9	5-3
General	3-1	3-1	Design Details	5-10	5-3
Framing Systems	3-2	3-1	Chapter 6		
Load Types	3-3	3-1	Design Analysis and Detail Requirements		
Load and Resistance Factor Design	3-4	3-5	Gate Analysis Methods	6-1	6-1
Commentary on Loads and Load Factors .	3-5	3-5	Component Design and Detailing	6-2	6-2
Serviceability Requirements	3-6	3-7	Chapter 7		
Fatigue and Fracture Control	3-7	3-7	Operating Equipment		
Material Selection	3-8	3-9	General	7-1	7-1
Weldments	3-9	3-9	Types of Hoists	7-2	7-1
Design Details	3-10	3-10	Dogging Devices	7-3	7-2
Chapter 4			Lifting Beams	7-4	7-2
Spillway Crest Gates			Chapter 8		
General	4-1	4-1	Corrosion Control		
Framing Systems	4-2	4-1	General	8-1	8-1
Load Types	4-3	4-1	Coating Systems	8-2	8-1
Load and Resistance Factor Design	4-4	4-3	Cathodic Protection	8-3	8-1
Commentary on Loads and Load Factors .	4-5	4-4	Control Contamination	8-4	8-1
Serviceability Requirements	4-6	4-4	Design Details	8-5	8-1
Fatigue and Fracture Control	4-7	4-4	Commentary	8-6	8-2
Material Selection	4-8	4-5	Safety	8-7	8-2

Subject	Paragraph	Page	Subject	Paragraph	Page
Chapter 9			Plates 1-12		
Maintenance Considerations			Appendix A		
General	9-1	9-1	References		
Bulkheads	9-2	9-1	Appendix B		
Lubrication	9-3	9-1	Case Histories		
Inspection	9-4	9-1			

Chapter 1 Introduction

1-1. Purpose

The purpose of this manual is to provide guidance in the structural design of vertical lift gates.

1-2. Scope

This manual presents criteria for the design of vertical lift gates used for water retention for routine or emergency operation in navigation projects, powerhouses, spillways, outlet works, and coastal hurricane protection or tide gates. For other types of gates, such as sluice gates, bonnet type gates, maintenance bulkheads, and slide gates, specific criteria have not been developed.

1-3. Applicability

This manual applies to all USACE Commands having responsibility for design of civil works projects.

1-4. References

References are listed in Appendix A.

1-5. Background

a. General. Several types of vertical lift gates are used in a variety of hydraulic structures, including spillways, low-level inlets/outlets, powerhouses, and navigation locks. In

recent years, there have been considerable problems with the performance of vertical lift gates. The majority of these problems have occurred as a result of fatigue, causing fractures in main structural framing members of the gate. New criteria address methods to reduce fatigue and fracture through design and construction techniques. Research has proven that the serviceability of the gate can be improved by using proper materials and fabrication techniques. These fabrication techniques include the use of proper joint detailing and welding procedures. Proper material selection and material compatibilities are an essential part of providing long service life of the structure.

b. Recent case histories. Numerous gates have experienced problems related to fracture and fatigue. Results of investigations, most notably published in Engineer Technical Letter (ETL) 1110-2-346 and ETL 1110-2-351 and Computer-Aided Structural Engineering (CASE) Steel Structures Task Group (1993), identify methods for reducing fatigue stresses and selecting material type, which result in longer design lives for welded steel structures. Two case histories provided in Appendix B describe a background of failures in the existing gates, corrective actions taken, and replacement of the old gate with a new gate using new fatigue guidelines.

c. Design policy. Engineer Manual (EM) 1110-2-2105 specifies that Load Resistance and Factor Design (LRFD) is the preferred method of design and should be used for those structure types for which LRFD guidance is provided. Hence, this manual contains load criteria specified for designing vertical lift gates using LRFD. The designer is referenced to the design policy in EM 1110-2-2105 regarding the use of allowable stress design.

This engineer manual supersedes EM 1110-2-2701, dated 7 December 1962.

Chapter 2 Description and Application

2-1. General

Vertical lift gates are used for navigation lock chamber gates, emergency closure gates for powerhouse intakes and outlet works, and spillway crest gates. Each type of gate used has its advantages and disadvantages and is designed to accommodate special requirements for closure and retention of hydraulic head.

2-2. Gate Types and Applications

a. Navigation locks. Navigation locks may use overhead or submersible lift gates and are described below. EM's 1110-2-2602, 1110-2-2607, and 1110-2-2703 provide information on other types of gates for navigation locks.

(1) Overhead gates. These types of gates use a tower with overhead cables, sheaves, and bullwheels to support the gate during its operation and counterweights to assist hoisting machinery. The tower height is governed by the lift required to pass barge traffic. These gates can be a plate girder, horizontal tied arch, or horizontal truss, which are discussed in Chapter 3. Examples of a horizontal truss and tied arch are shown in Plates 1-3. These gates are often used as tide or hurricane gates along the seacoast and for inland navigation locks. When they are used as hurricane gates, they are normally raised to permit normal water traffic to pass underneath and lowered to protect harbors from tidal storm surges. This type of gate would be used in the following situations: it is not practical to use submersible gates (as with high-head applications); when sufficient support cannot be provided for transferring thrust from miter gates; the available area to place the gate monolith is limited and will not permit the use of miter gates; or when the gate is used as a hurricane or tide gate and is subject to reverse hydrostatic or hydrodynamic loadings.

(2) Submersible gates. A submersible gate can be used as the upstream gate for a navigation lock, where the submersible leaf rests below the upstream sill. There are two types of submersible gates: single leaf and multiple leaf. The double leaf arrangement is most common. It is composed of a downstream leaf, used for normal lock operation, and an upstream leaf, used infrequently as a movable sill or as an operating leaf in an emergency. This is referred to as the emergency leaf. An example of a downstream leaf is shown in Plates 4 and 5. Both leaves are normally constructed of horizontal girders with an upstream skin plate. The hoist components at either side of the lock are mounted above the high water in a concrete recess with a removable roof section. The powered hoist component is mounted on a structural steel frame anchored to a concrete

structure on one side of the lock. The nonpowered component is then mounted on the opposite wall. For the normal open or stored position, the leaves are lowered into the sill. The emergency leaf is used for lock closure in the event of an accident or damage to the gate that would otherwise result in loss of the navigation pool. This type of gate is useful when it is necessary to skim ice and drift from the lock approaches or open the lock gates to pass flood flows.

b. Spillway crest. This type of gate is sometimes preferred over tainter gates because the spillway crest requires a shorter length of spillway pier and provides a more economical pier design. These gates are usually raised by using the gantry crane or fixed hoists for each gate located on the spillway deck or operating platform. Dogging devices are sometimes provided to engage projections spaced at intervals on the gate to hold the gate at the proper elevation. In some cases it may be advantageous to mount the dogs in the gate and provide a dogging ladder in the gate slot; however, the other arrangement is preferred. Different types of spillway crest gates are as follows:

(1) Single section. This gate consists of one section that provides a variable discharge between the bottom of the gate and the sill. Single-section gates operate similarly to the multiple-section gates but are dogged off in the service slots.

(2) Multiple section. A multiple-section gate consists of two or more sections in the same slot with variable discharge between the sections or between the bottom section and the sill. Multiple-section gates can be equipped with a latching mechanism to allow use as a single-section gate. As the required discharge increases beyond the capacity of the largest opening between sections, top sections are removed from the service slots and dogged above the pool level in emergency slots. The latching mechanisms should be carefully designed so they do not stick or corrode. This has been a maintenance problem for some projects. The top section of a multiple-section gate is shown in Plate 6.

(3) Double section. This gate consists of two sections in adjacent slots with variable discharge over the top section or beneath the bottom section. The double-section gate is used less frequently because removing the gate from the slot is more cumbersome, sealing is more complicated, and additional length of pier is required. This type is useful for skimming ice and trash; however, that function can also be performed by shallow top sections of a multiple-section gate that are lifted clear of the pool.

c. Outlet gates. Often, lift gates are used for emergency closure of water intake systems or outlet works. Their normal operation is in the open position. They are not used for throttling flows; however, they are used to stop flow under

operating conditions. They normally rest on dogging devices during normal operation. In emergencies, they are lowered into the closure slot to stop the flow of water.

(1) Powerhouse. Emergency gates are required for sudden closure of the turbine intakes to prevent subsequent damage to the turbines or powerhouse. These types of gates are normally framed with horizontal girders and a downstream skin plate. Upstream skin plates may be used when silt or mud fills up girder webs. Diaphragms are used to transfer vertical loads from the hoists. The hoisting system uses either hydraulic cylinder(s) or wire ropes. The type of hoisting system will be based on economics and governing criteria for closure times under emergency conditions. The hoisting system for wire ropes may be deck mounted or placed in recesses above the high pool elevation. Cylinders for the hydraulic system are mounted below the deck in the intake gate slot. See EM-1110-2-4205 for additional information and requirements. Because these gates must be capable of operating under full head and flowing water, tractor type gates are used to reduce friction. See paragraph 2.3 for descriptions of types of end supports. Plates 7, 8, and 9 depict this type of gate.

(2) Outlet works. Emergency closure gates for outlet works are similar to those used in powerhouses and are often used for service gates and flow control. Using tractor gates for fully submerged outlet works, as used in intake towers, is usually advantageous due to the reduced friction under full head and flow. However, many gates use wheels where loading allows. The hoisting system may require the use of a gantry crane or its own hoisting system, either wire rope or hydraulic.

2-3. Types of End Supports

End supports for vertical lift gates may be classified according to the method used to transfer the loads to the gate guides. The gate guides receive the main reaction component from horizontal loads.

a. Fixed wheel. With this type of end support, the wheels revolve on fixed axles, which are either cantilevered from the body of the gate or supported at each end by the web of a vertical girder(s) attached to the gate frame. The wheels may also be mounted by pairs in trucks that carry the wheel loads through center pins to end girders attached to the gate frame. When gate hoisting occurs with no static head, this type of end support will usually be most economical. The fabrication is generally less costly than using tractor type end supports, described in (b) below. When the gate is used for outlet works, this type of end support will receive higher point loads. This will cause a much higher bearing stress to the wheel and guides, as well as shear, bearing, and bending forces to the center pins and end girder. This type of end support is

normally used in navigation lock gates or where the gate is used to control flows while under low static head as with spillway gates or emergency closure gates. When used for navigation lock gates, the wheels normally rest in a wheel recess to prevent them from transferring hydrostatic loads. With the wheels in the recess, horizontal loads are transferred through an end bearing shoe to the pier bearing surface. Hence the wheels carry no hydrostatic load. Hydrostatic load is then transferred from end bearing shoes on the gate to the gate guides. Refer to Chapter 6 for design and detailing information.

b. Tractor (caterpillar). This type of end support, also referred to as caterpillar, has at each side of the gate one or more endless trains of small rollers mounted either directly on members attached to or on the vertical end girder. This type of end support system is shown in Plates 8 and 9. Roller details are depicted in Plate 7. These are more commonly found on emergency closure gates or gates that control flow under high head. Because load transfer is achieved by uniformly distributed bearing through the small rollers, they are able to withstand large horizontal loads while being lowered under full hydrostatic head. Their main advantages over fixed wheels are a lower friction component while hoisting under load, lower bearing stresses transferred to the guides and gate framing, and shear and bending not transferred to the gate through the axle. When compared to slide gates, the main advantage is reduced friction, which reduces the hoisting effort required for controlling flow. This reduced friction also reduces the wear and maintenance compared with those of slide gate seal surfaces.

c. Slide. Slide gates use metal to metal contact for end support. A machined surface that is mounted to the front face of the gate bears directly against a machined guide surface in the gate slot. The two bearing surfaces also serve as the gate seal. Materials for the gate seal surface may include aluminum, bronze, or stainless steel. These types of gates are normally used in intake/outlet tunnels where a head cover (bonnet) is used to seal off the guide slot from the gate operator for submerged flow installations. They can be used for high heads; however, the head during flow control in combination with the width and height of the inlet/outlet tunnel will determine the feasibility for using slide gates. The bearing surfaces of the guides and slide bearings must be machined to tight tolerances to maintain a seal for the gate. This requires tighter construction tolerances for installation of the guides and slide bearings than with tractor gates and fixed-wheel gates, which use J seals along a seal plate.

d. Stoney. Similar to a tractor gate, a Stoney gate uses a small train of rollers; however, the fundamental difference is that the roller axles are held in position by two continuous vertical bars or angles on either side of the roller. The load is

transferred from a bearing surface on the gate, through the rollers, to the guide bearing surface on the monolith. The entire roller train is independent from the gate and the guide, which allows free movement of the roller train. In order to maintain the roller train in its proper vertical position, it is common to use a wire rope support. The rope is fixed to a point on the gate, passes around a sheave fixed to the roller train, and is fixed to a point on the pier or monolith. Lateral movement is prevented by vertical bars or axles along the guide surfaces. A unique feature of this type of load transfer system, as in tractor gates, is that axle friction is not developed; hence there is a much lower friction component attributed to rolling friction. The main advantages of this type of gate support system are the same as those for the tractor gates.

2-4. Advantages/Disadvantages

a. General. The use of overhead or submersible lift gates for navigation locks versus miter gates, sector gates, or submersible tainter gates would be based on economics, riverflow operational criteria, and navigation lock configuration. Some of the main advantages of using vertical lift gates are ease of fabrication, considerably shortened erection time, and in most cases, shorter monoliths or supporting piers for spillways, powerhouse intakes, and navigation locks compared with those of tainter or radial gates. The load from the gate to the supporting pier or monolith is in one direction, simplifying the design of the supports. One main disadvantage when using vertical lift gates that are under constant cyclic loading is that the main load resisting frame relies on a tension flange or, in the case of an arch, tension tie. In these cases fatigue plays a primary role in their design. The use of fixed-wheel, tractor, Stoney, or slide gates versus tainter gates for spillways and outlets also depends on head, size of gate, riverflow operational criteria, and economics.

b. Navigation locks. For high lift requirements, or when the leaf of a submersible gate must rest on the bottom of the lock chamber or in a recessed sill, an overhead gate would be more desirable than a submersible gate. In the case where submersible leaves rest on the bottom of the lock chamber or in a recessed sill, silt would lead to hoisting problems, weak axis loading to the girders, and higher maintenance costs. Where there are high lift requirements, a submersible gate would require multiple leaves to obtain the lift required to pass river traffic. This may not be advantageous when considering

hoisting arrangements and costs. Where debris and ice must be passed through the lock, a submersible gate would be more advantageous than an overhead, miter, or sector gate. For a multiple-leaf submersible gate, the downstream leaf is lowered to allow flow through the lock to pass ice or debris. A disadvantage of the use of overhead lift gates is that a tower is required to house the mechanical equipment and to gain sufficient lift for barge traffic to pass through the lock. This can cause increased design effort, in which flexibility in the tower must be accounted for in the design of the guide/hoisting system. Undesirable cracking of the monolith can occur if the tower/ monolith interface is not designed to account for the tensile stresses developed from flexure of the tower. This was observed in Ice Harbor's navigation lock, Snake River, Washington, shortly after it was placed in service.

c. Spillway. For spillway crest gates, tainter gates are preferred over vertical lift gates. This is due primarily to lower maintenance. When multiple-section vertical lift gates are required, the latching mechanisms can become inoperable unless continued maintenance is performed. This can increase maintenance activities and should be avoided if possible. However, vertical lift gates would be preferred to tainter gates when the elevation of the maximum controlled pool is so far above the sill that excessively long piers would be required for tainter gates or flood discharges or drift conditions are such that any obstruction to the flow below the bottom of the spillway bridge is undesirable, requiring the gate to be removed.

d. Outlet gates. For powerhouse intake gates the normal preference for use would be a vertical lift gate, due primarily to savings in the length of the intake pier and ease of construction. The time savings would occur for gates used for outlet works. Normal use for these types of gates is a tractor gate due to its low friction during operation. The size of gate and head requirements determine the feasibility of slide, fixed-wheel, or tractor gates. Slide gates require precise machined tolerances on the seal surfaces from the gate to the bearing guides. This requires careful quality control during field installation. Wear and damage to the slide and bearing surfaces due to use and cavitation can require higher maintenance to the slide gate. It may be more cost effective to replace wheels, rollers, or seals on a fixed-wheel or tractor gate than to fill and machine the gate and bearing surfaces of a slide gate.

Chapter 3 Navigation Lock Lift Gates

3-1. General

Almost all lift gates use a horizontal framing system. Vertical framing systems are not structurally efficient in transferring loads to the side bearing surfaces and require special framing to accommodate roller guides for hoisting operations. Vertical framing systems are not recommended for new vertical lift gates, except where being replaced in kind. For navigation locks, framing for either the upstream or downstream gate uses girders, trusses, or tied arches. The framing system selected will depend on span, hydrostatic head, and lift requirements.

3-2. Framing Systems

a. Girders. Horizontal plate girders are the main force-resisting members of the gate. They consist of built-up plate elements forming the stiffened webs and flanges of the girder. The spacing of the girders will depend on the head requirements, the height of the gate, and the clear span. For short gates, it is not advantageous to vary the spacing of the girders; however, for taller gates where the change in hydrostatic loading will be more significant from the bottom sill to the top, it is more economical to vary the spacing. Varying the spacing will require additional attention to design of the intercostals and skin plate to compensate for the varying hydrostatic pressure and span between girders. The girders frame into end posts that transfer end shear from the girders to bearing, either on the gate guides or through the types of end supports described in paragraph 2-3. Intercostals are framed plates or structural shapes that span the layers of horizontal girders used to create two-way plate bending action for the skin plate. Diaphragms are used to provide continuity of the gate by distributing horizontal loads more uniformly and supporting and distributing vertical loads. These other framing members are described in Chapter 6. Examples of horizontal girder framing are contained in Plates 4-6, 8, and 9.

b. Trusses. Trusses may be more economical or weigh less than plate girders. Horizontal trusses would be most economical for navigation locks with high-lift overhead gates or for long horizontal spans across navigation locks. It may be advantageous to vary the spacing of the main trusses to achieve an economical arrangement of the same truss and member sizes throughout the height of the gate. Plate 3 represents a typical use of horizontal trusses for navigation lock framing. Common members used for the trusses are wide flanges and structural T's. The main trusses frame into an end post supported by an end bearing similar to a stiffened plate girder. Special framing requirements need to be considered for the

roller guides in the upstream/ downstream and lateral directions. As with girders, other framing members include intercostals, diaphragms, end posts, stiffeners, and skin plates. These are described in Chapter 6.

c. Tied arches. This type of framing, as with trusses, is normally employed for high-head and long span gates used in navigation locks. Because of the load transfer ability of the arch, this framing is generally more structurally efficient than plate girders. Particular care must be used in designing the main tension tie, as there is little redundancy if it fails. Therefore fatigue design becomes most critical for these members, particularly in the connection of the arch girders to the main tension tie. The members can be made of rolled shapes, built-up members, solid plates, or plate girder members. Normally the front arch is framed with structural T's, with the webs welded continuously to the skin plate. Plates 1 and 2 represent a vertical lift gate of this type. Most recently, in the case of the replacement of Ice Harbor's downstream vertical lift gate, the arch and tension tie consisted of horizontal plate members. This type of design was employed to eliminate poor fatigue performance at the connection of the upstream arch to the downstream tension tie. Details from Plate 1 should not be used for current design. Its connections experienced severe fatigue. Current design standards for fatigue were used for the design of the replacement gate. More information is provided in Appendix B. As with girders, other framing members include intercostals, diaphragms, end posts, stiffeners, and skin plates. These are described in Chapter 6.

d. Vertical framing. This type of framing system is not very common and is not recommended for use. However, this type of gate may be more economical if it is being used to replace a gate of the same type. Vertically framed gates most commonly use stiffened plate girders. With this type of system the main load is transferred from the skin plate to vertical girders that frame into a horizontal main girder at the top and bottom of the gate. The load transfer is through the top girders to the end wheels at the guide recess. This arrangement is unsuitable for large gates because of the concentration of load at the top and bottom of the end posts.

3-3. Load Types

The following load types are applicable to vertical lift gates used in navigation lock structures.

a. Hydrostatic. The hydrostatic load H_s shall be determined based on site-specific conditions for upper and lower pool elevations.

(1) For submersible gates, consideration must be given to the operation of a multiple-leaf gate, with the gate seals effective and ineffective. Figure 3-1 represents a typical

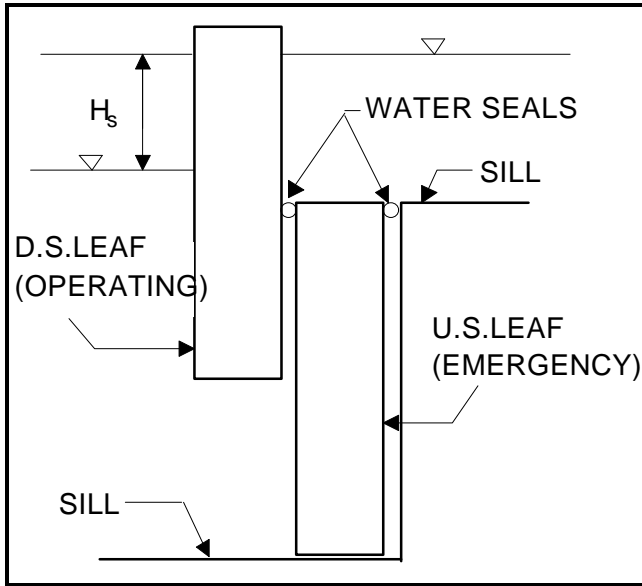

Figure 3-1. Submersible lift gate, normal operation

double-leaf submersible gate configuration with seals noted. With this arrangement the two leaves will be subject to differing hydrostatic loads. This arrangement should consider normal operation, using the downstream leaf as the operating leaf; operation of the downstream leaf when skimming ice or debris (hydrodynamic load described in *b(1)* below); and use of the upstream leaf during emergency gate operation should the operating leaf fail. Figures 3-2 and 3-3 represent the case where the downstream leaf is used for normal operation, with the gate seal between the upstream and downstream leaf effective and ineffective, respectively. In this case, H_s represents the maximum head differential between upstream and navigation lock pool elevations. During normal operation, Figures 3-4 and 3-5 represent the hydrostatic load to the submerged (upstream) leaf with the seal between the upstream and downstream leaves effective and ineffective, respectively. For this condition H_s represents the maximum head differential from the upstream and navigation lock pools. When the upstream leaf is used for lock operation the same loadings must be applied to it, as in the case of the downstream leaf during normal operation.

(2) The hydrostatic load H_s and water seal arrangements for overhead gates with and without a crossover gallery are shown in Figures 3-6 and 3-7, respectively. For both conditions, H_s represents the maximum head differential between the navigation lock pool and downstream tailwater. For the case where an overhead gate is used for an upstream navigation lock gate, the loading conditions would be the same as for a single-leaf submersible gate, where H_s represents the maximum head differential between the upstream pool elevation and tailwater pool elevation, or upstream sill.

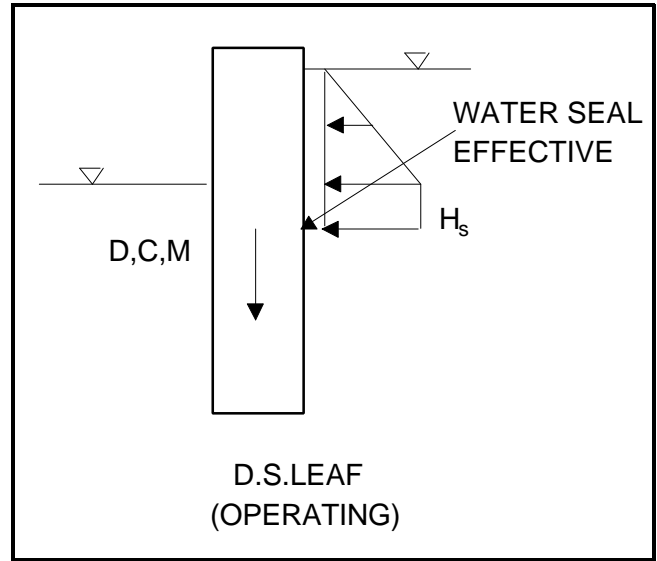

Figure 3-2. Submersible lift gate, hydrostatic loading diagram, downstream leaf, seals effective

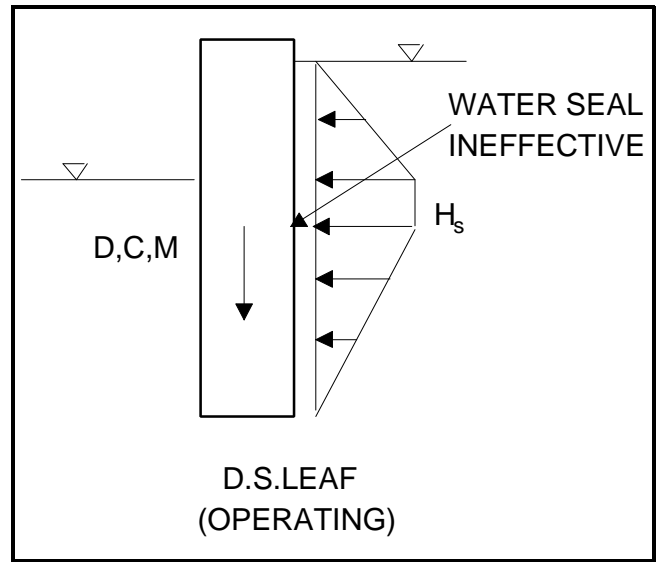

Figure 3-3. Submersible lift gate, hydrostatic loading diagram, downstream leaf, seals ineffective

b. Hydrodynamic. The hydrodynamic loads H_d shall be determined based on site-specific conditions for wave forces resulting from tides or coastal hurricanes applied to protection gates and for vertical loads from water flowing over leaves of submersible gates.

(1) For submersible gates, Figure 3-8 represents the operation of the downstream leaf when passing ice and debris. In this case, H_d represents the head from the flow overtopping the downstream leaf.

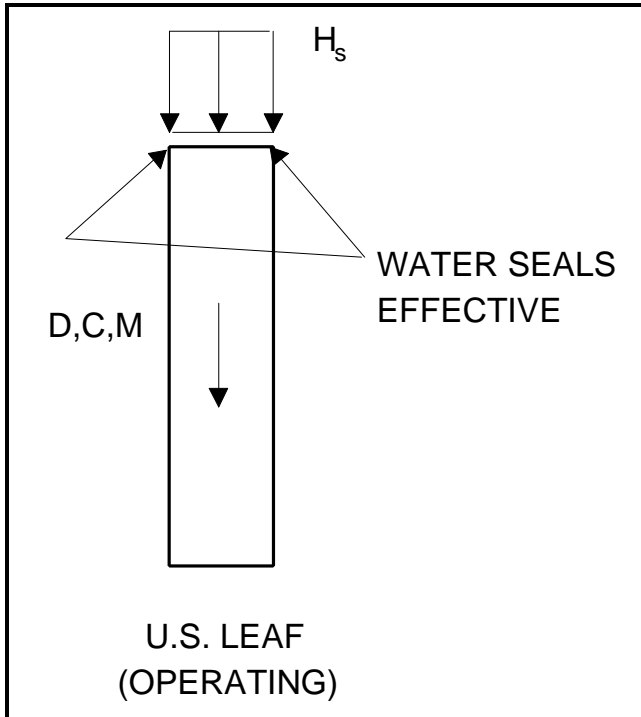

Figure 3-4. Submersible lift gate, hydrostatic loading diagram, upstream leaf, seals effective

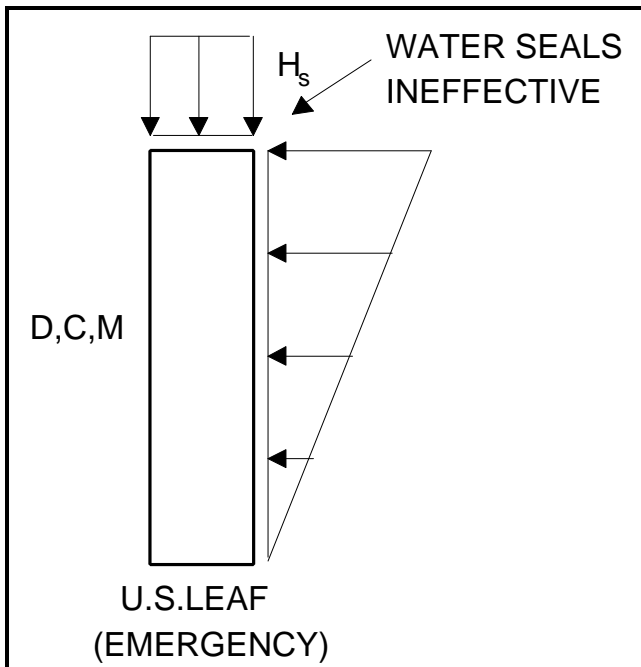

Figure 3-5. Submersible lift gate, hydrostatic loading diagram, upstream leaf, seals ineffective

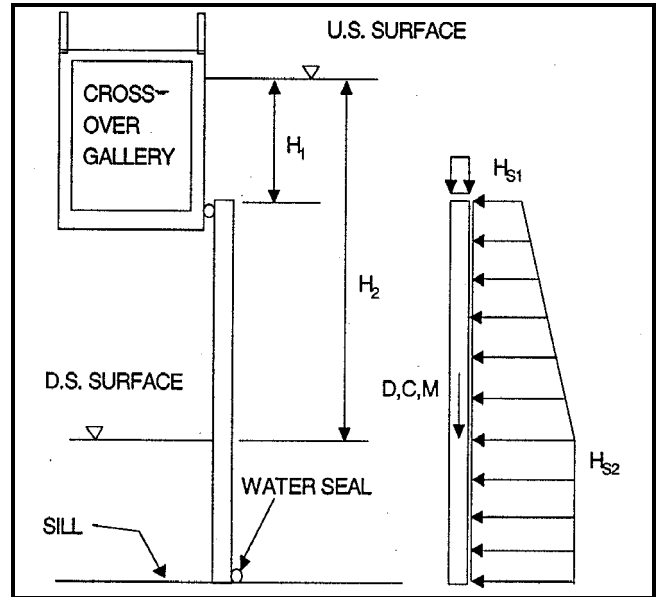

Figure 3-6. Overhead lift gate with crossover gallery, hydrostatic loading

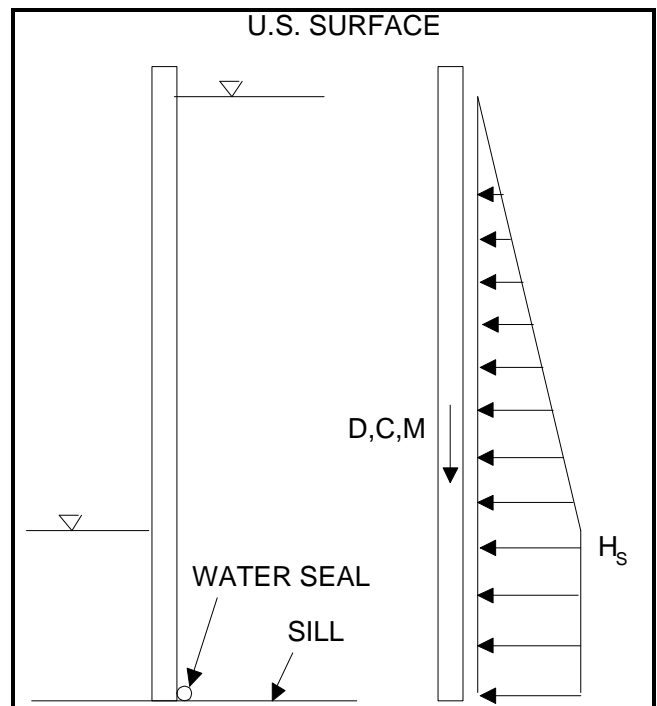

Figure 3-7. Overhead lift gate without crossover gallery, hydrostatic loading

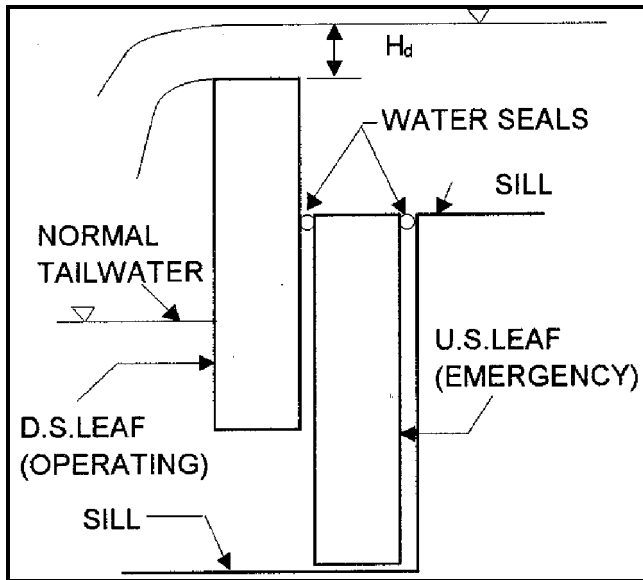

Figure 3-8. Submersible lift gate, hydrodynamic loading for passing ice and debris

(2) Hydrodynamic loads applied to tide or coastal hurricane gates shall be based on site-specific conditions. They shall include the effects of tidal hydraulics, water levels and wave heights, and necessary storm surge analysis to which the gate will be subjected. Distribution of wave forces is dependent on the wave height and depth of water at the structure. Their effects should be computed for a range of possible water levels and periods.

c. Gravity. Loads resulting from deadweight D , ice C , and mud M shall be based on site-specific conditions. Mud loads shall include silt loads where applicable. Ice loads are considered as gravity loads; lateral loads from ice are not considered in the load combinations.

d. Operating equipment. The maximum load that can be exerted by the operating machinery Q includes the effects of the deadweight D , ice C , and mud M ; and in the case of submersible gates, the effects of the hydrodynamic load H_d when the gate is used for passing ice and debris; and the effects of friction and binding of seals, slides, and wheels.

e. Impact. Submersible and overhead gates used for navigation locks are subject to barge impact loading I . The barge impact loading I shall be 1112 kilonewtons (kN) (250 kips) applied at any point on the lift gate span. For submersible gates, barge impact I will occur along the top girder of the operating (downstream) leaf. For overhead gates, the barge impact I shall be applied at any point on the gate at which a barge may collide, and at the point that produces the maximum structural effect. Gates subject to barge impact

loading need not be designed for ice and debris impact. Impact loads need be applied only to main load-carrying members.

f. Earthquake. Design earthquake load shall be determined based on an operational basis earthquake (OBE), defined in ER 1110-2-1806. The earthquake load E shall be based on inertial hydrodynamic effects of water moving with the structure. Sloshing liquid forces are small and may be ignored. The vertical distribution of the initial hydrodynamic pressures acting on the gate shall be determined from Westergaard's equation:

$$p = \frac{7}{8} g_w a_e \sqrt{Hy} \quad (3-1)$$

where

p = lateral pressure at a distance y below the pool surface, meters (m) (feet (ft))

g_w = unit weight of water, kilograms per cubic meter (kg/m^3) (pounds per cubic foot (lb/ft^3))

a_e = maximum acceleration of the supporting lock wall due to the OBE (expressed as a fraction of the gravitational acceleration g), constant

H = pool depth, m (ft)

y = distance below the pool surface, m (ft)

The lock wall shall be assumed rigid in determination of a_e , and the assumed direction of a_e shall be perpendicular to the gate. The inertial forces resulting from the mass due to structural weight D , ice C , and mud M are insignificant to the effect of p and need not be considered. For overhead gates, the effects of E shall be applied to the towers.

g. Downpull. Downpull forces are not applicable for navigation lock gates.

h. Thermal. The effects of extreme thermal differentials T , caused by ambient air and water temperatures adjacent to the exposed faces of the gate, shall be determined based on the navigation lock at full pool, exposing the skin plate to the pool temperature and the downstream girders or tension ties to ambient conditions and tailwater. This shall include temperature differentials related to seasonal ambient and water temperatures. For moderate climates the ambient temperature range shall be from -18 to 49 °C (0 to 120 °F), and for cold climates from -34 to 49 °C (-30 to 120 °F). Pool temperatures shall be based on observed or recorded data and applied to the season during which the maximum ambient temperatures are predicted to occur.

i. *Wind loads.* Wind loads W shall be based on site specific conditions. American National Standards Institute (ANSI) A58.1/American Society of Civil Engineers (ASCE) 7-95 (ANSI/ASCE 1995) shall be used to determine wind pressures acting on the gate. Wind load shall be applied normal to the projected surface of the gate. For submersible gates, wind loads need not be applied.

3-4. Load and Resistance Factor Design

a. *Design guidance.* Navigation lock vertical lift gates shall be designed using LRFD methods in accordance with EM 1110-2-2105. A synopsis of the methodology and general guidance for use of LRFD for hydraulic steel structures (HSS) is presented in EM 1110-2-2105 and will not be repeated here. Design resistance and reliability factors shall conform to the requirements in EM 1110-2-2105.

b. *Load cases and load factors.* Lift gates shall have design strengths at all sections at least equal to the required strengths calculated for the factored loads and forces in the following load combinations. The most unfavorable effect may occur when one or more of the loads in a particular load combination is equal to zero. For each load combination the gate should be considered supported on either its fixed supports or by the hoisting equipment.

$$1.2D + 1.6(C + M) + 1.3W \quad (3-2)$$

$$1.0D + 1.0(C + M + H_d) + 1.2Q \quad (3-3)$$

$$1.2D + 1.4H_s + 1.2T + 1.0I \quad (3-4)$$

$$1.2D + 1.2H_s + 1.6H_d \quad (3-5)$$

$$1.2D + 1.2H_s + 1.0E \quad (3-6)$$

3-5. Commentary on Loads and Load Factors

a. *Loads.*

(1) Hydrostatic.

(a) The loadings shown for submersible gates are based on typical two-leaf submersible gates. A single-leaf submersible gate will simplify the number of hydrostatic load cases, while multiple leaves greater than two will increase the hydrostatic head load cases. Operation of the gate is the critical factor that determines the number of load cases to check for the design of the gate. The load cases represented by Figures 3-3 and 3-5, where the seals between the leaves and the gate and upstream sill are ineffective, are the most extreme case where the seal is completely ineffective and does not resist H_s . These loadings may be neglected when they cause less effect than the

full hydrostatic loading when the gates are raised. Figure 3-5 shows the hydrostatic loading on the upstream leaf when the seal at the upstream sill is ineffective. Because the upstream leaf of a submersible gate is adjusted to account for varying pool levels, no seal is made at the bottom of the leaf. Even with the upstream leaf lowered completely, no seal is made at the bottom. Gate rests at the bottom of the lock are generally individual pedestals that permit the free flow of water. Hence, the net pressure at the bottom of the leaf is zero. A linear load distribution is assumed to act between the bottom of the leaf and the upstream sill, where hydrostatic pressure H_s exists. Figure 3-3 represents the downstream leaf loading when the seal between the upstream and downstream leaves is ineffective. Because there is no seal at the bottom of the downstream leaf, the net pressure at the bottom of the leaf is zero. Similar to the upstream leaf, a linear load distribution is assumed to act between the bottom of the leaf and the location of the ineffective seal, varying from zero at the bottom of the leaf to H_s at the location of the ineffective seal. Conditions that may cause this type loading are neglected maintenance or damage to the seal or seal assembly. Even though the gate can resist this condition, the seal design should still ensure 100 percent effective seals under all operational conditions.

(b) Some navigation locks use a downstream crossover gallery, particularly when using a vertical lift gate. When this is a part of the water retention system for the navigation lock, the hydrostatic load H_{sl} is applied vertically to the top girder and horizontally to the top of the gate, and H_{s2} represents the maximum head differential between the upstream and downstream pool (Figure 3-6). Prior to acceptance of the gate during construction, the contractor may be required to demonstrate watertight requirements. For the bottom seal watertightness to be evaluated, the downstream area will have to be dry. In this case the designer is cautioned to provide an adequate design that will demonstrate seal effectiveness and yet assure that the gate can resist the test loading, without the downstream pool acting on the bottom portions of the gate.

(2) Hydrodynamic.

(a) The total amount of head overtopping the operating leaf shall be determined by investigation of river hydraulics and operational criteria. H_d shall be determined by existing operational data or conditions for submersible leaves that are replacing old gates in the same structure. For new projects, EM 1110-2-2602 refers to the use of hydrologic and hydraulic studies, including model studies, as a necessary part of defining the physical characteristics of the navigation lock. These studies should also define the operational characteristics of the project for passing ice and debris, including H_d . Further information on operational methods for passing ice and debris through navigation dams is found in EM 1110-2-2607.

(b) Hydrodynamic loads resulting from wave forces will occur as a result of differing water levels and direction of wave. During the development of coastal projects, complete analysis of tidal hydraulics, water levels and wave heights, and storm surge will determine the appropriate loading conditions for the gate. Preliminary design loads can be determined from EM's 1110-2-1412, 1110-2-1414, 1110-2-1614, and 1110-2-1607, which provide information to develop hydrodynamic loads for tidal gates. Pressure distributions for breaking and nonbreaking waves can be developed from criteria in EM 1110-2-1614. It should be noted that criteria in EM 1110-2-1614 require hydraulic model tests to be performed for most designs featuring coastal revetments, seawalls, and bulkheads. Hence, the structural engineer should consult with the hydraulic engineer for final determination of these loads.

(3) Gravity. Ice and silt or mud vary based on site-specific information. Data or observations for replacement of existing gates may be used to determine C or M . For new projects, EM 1110-2-2602 suggests that only model studies can indicate silt buildup, and that only the most conservative assumptions for depth of silt should be used. For gates being used in similar river systems, with similar silt loads, estimates based on other projects may be used.

(4) Operating equipment. Coordination between the structural and mechanical engineers is required to determine the operating equipment loading. The mechanical engineer will need gate deadweight D , hydrodynamic load H_d , ice C , mud M , and friction load to determine operating equipment requirements, including inertial effects.

(5) Impact. It is not reasonable to design a gate to resist a high-speed barge impact. Experience has shown that designing for an impact load of 1112 kN (250 kips) will provide adequate resistance to impact damage.

(6) Earthquake. The inertial hydrodynamic effects are consistent with past and present methods of analysis. The use of Westergaard's equation gives conservative results, and for gates of this type, earthquake loads normally do not control the design.

(7) Downpull. Downpull forces are not applicable for navigation lock gates. These loads are considered primarily for emergency closure or spillway crest gates, which are deployed during flowing conditions.

(8) Thermal. This condition may occur with navigation lock gates when the temperature of the skin plate against the full navigation lock pool may cause a considerable temperature differential between other structural members exposed to ambient conditions. Generally, T will not control the design; however, in some gate designs, there may be considerable

stiffness in the downstream bracing between girders, or tension ties in arches, that will develop additional stress. Another contributing factor that should be considered is restraint due to friction at the end supports. This may require the member or connection to be designed differently when considering fatigue. The ambient temperatures specified are consistent with those specified in American Association of State Highway and Transportation Officials (AASHTO) (1996) for metal structures.

(9) Wind. Wind loads W for most navigation lock gates are small and can usually be ignored. However, in the case of an arch or truss girder system, wind may cause compressive loading to the tension tie or chord of the truss. This condition will require consideration of slenderness effects for those members.

b. Load cases and load factors.

(1) Load factors for miter gates have been developed and are presented in EM 1110-2-2105. The development of load factors for vertical lift gates included consideration of the respective load variability, definition, likeness to those loads specified in American Institute of Steel Construction (AISC) (1995), and likeness to load factors developed for miter gates. Postulated loads I and E are given a load factor of 1.0 since it is assumed that the conservatism necessary for design is taken into account in the associated hazard scenario and specification of the nominal load.

(2) Equation 3-2 provides a check for maximum vertical loads on members and lifting anchor points in combination with wind. Certain members in truss or arch type navigation lock gates such as tension ties or tension chords should be checked for slenderness effects caused by compression loads from W . Wind can cause reverse loading and should be considered when determining the maximum effects during hoisting operations. For horizontal girder type gates, the combination of D , C , and M will control the location of support spacing or bracing for out-of-plane loading in these members, and will provide adequate bracing for the compression flange.

(3) Equation 3-3 provides a check for maximum vertical loads from operating equipment. In this case Q represents the maximum load that can be applied to the gate considering that the gate may bind. Deadweight D , ice C , mud M , and hydrodynamic load H_d are opposing forces from the gate.

(4) Equation 3-4 provides a check for normal operating conditions with lateral impact forces. The effects of thermal temperature differentials shall be considered as part of the normal operating conditions when seasonal temperatures cause increased member stresses and as part of the fatigue life. Temperature effects may be neglected when they cause less effect than the full hydrostatic loading.

(5) Equation 3-5 provides a check for various conditions related to moving water for submersible gates supported by hoists when skimming ice and debris. It is also used to check for wave forces for coastal hurricane protection gates.

(6) Equation 3-6 combines seismic loading with hydrostatic loading. The hydrostatic loading for this combination should be one that occurs frequently during each year. Seismic loads should not be combined with other infrequent events such as floods or hurricanes.

3-6. Serviceability Requirements

Vertical lift gates shall be designed for an expected life of 50 years. Limiting values of structural behavior to ensure serviceability (i.e., maximum deflections, vibrations, ease of maintenance, etc.) shall be chosen to enable the structure to function as intended for its design life. Normally, serviceability can be evaluated using unfactored loads. As a minimum, the following guidance should be observed.

a. Testing during erection. Vertical lift gates should be completely fitted together in the shop, if size permits, to ensure satisfactory field connections. Tolerances should not exceed 2 millimeters (mm) (1/16 inch (in.)) for individual members up to 10 m (30 ft) in length and not more than 4 mm (1/8 in.) for members over 10 m (30 ft) in length. Structures made from two or more members shall not deviate from the overall dimension by more than the tolerance for any one member. Rubber seals should be fitted to the gate and assembled in the shop and then removed for shipment. Before disassembly of the gate, each piece should be match-marked to facilitate field erection. Care should be taken to ensure that all parts of the gate leaf are in proper alignment before any field welding is commenced. All necessary precautions should be taken to prevent distortion of the gate as a whole or of any of its components. Each unit shall be accurately aligned so that no binding of any moving parts or distortion of any members occurs before final connections are made.

b. Deflection. Skin plate deflection is limited to 0.4 times the plate thickness. This is to prevent excessive deflection of the skin plate, which may result in serviceability problems. If deflections exceed 0.4 times the thickness of the plate, the large deflection theory for plates must be considered. The overall deflection of the gate and hoist shall be minimized to prevent impairment of operability and performance.

c. Vibration. Vibration of the structure, seals, or operating equipment shall not impair operability or performance.

d. Corrosion. Structural components shall be designed to tolerate corrosion or be protected against corrosion that may impair the serviceability or operability of the structure. It is

recommended that structural plates rather than flanged sections be used for stiffeners to facilitate application of the paint system.

e. Closure. Bulkhead slots should be placed to allow the gate to be taken out of service for maintenance. Bulkheads are discussed in Chapter 9.

3-7. Fatigue and Fracture Control

a. Fatigue requirements. Members and their connections subjected to repeated variations of load shall be designed for fatigue. For lift gates used at navigation locks, the total number of loading cycles shall be based on changes in load due to lock operation. The stress range of members and connections due to unfactored loads shall be less than or equal to the allowable stress range given in Appendix K of AISC (1995). Research and documentation of fatigue and fracture mechanic evaluations are presented in ETL 1110-2-346 and ETL 1110-2-351. They may be used as guidance in determining the material type and fatigue life of the structure. AISC (1995) does not require fatigue effects to be considered for members with a stress range that is completely in compression; however, because of the probability of large residual tensile stresses caused by welding processes, EM 1110-2-2105 requires that both tensile and compressive welded connections in hydraulic steel structures be checked for fatigue. Special considerations for vertical lift gates and recommended details for fatigue design of vertical lift gate components are discussed in *b* below. Because vibration results in unknown load magnitudes and number of cycles, details for all connections shall be selected to limit fatigue damage.

b. Special considerations for fatigue. The major factors governing fatigue strength are the applied stress range, the number of loading cycles, and the severity of an induced stress concentration. For design there are two options available: the type of connection and limiting the stress range to acceptable levels. Details that provide the lowest allowable stress range involve connections that experience fatigue crack growth from weld toes and weld ends where there is a high stress concentration. Often, high concentrations of residual stresses occur where two or more welds are allowed to intersect.

(1) Downstream bracing connections. Experience has shown that fatigue problems exist when downstream bracing members, usually structural angles or tees, are welded to the downstream flanges of the plate girders. The function of the downstream bracing is to provide stability for the downstream girder flanges and support for vertical loads. The problem is most severe with vertical lift gates used at navigation locks that support large vertical loads, due to a submerged head condition or a large dead load, in combination with a large number of

loading cycles. The standard procedure for connecting the bracing to the downstream flanges has been to use a welded gusset plate or weld the member directly to the girder flange. In this case it is extremely difficult to avoid a stress category E (AISC 1995, Appendix K), which may have a very low allowable stress range depending on the number of cycles of expected loading. Several options are available to design for this condition:

(a) Increase member sizes to reduce stresses.

(b) Increase girder spacing, thereby increasing the slope of diagonal members, which will tend to lower diagonal member forces.

(c) Bolt the gusset plate to the girder flange instead of welding. This will increase the gusset-to-flange connection to category B for the girder flange.

(d) Use a connection detail that embodies a transition radius. If a transition radius is used, the most benefit is obtained by using a larger radius (see AISC 1995, Appendix K).

(e) If girder spacing is not large, a more practical solution may be to eliminate the downstream bracing and connections by using a downstream skin plate (Plate 5). A downstream skin plate will require holes to allow for inspection and to release water or air as the gate is raised and lowered.

(2) Plate girder web stiffeners. Cracks in downstream girder flanges have occurred in existing vertical lift gates used at navigation locks, initiating at the intersection of the web-to-stiffener weld and the web-to-flange weld. The intersecting welds combined with a category E connection detail provide a point of crack initiation. To avoid this situation, plate girder web stiffeners shall be stopped short of the tension (downstream) flange, except where they may be required for bearing transfer. EM 1110-2-2105 requires that compression members also be checked for fatigue effects; therefore, do not extend web stiffener welds to the intersection with the web-to-compression-flange weld. A large chamfer or "rat hole" should be cut in the web stiffener to prevent the welds from intersecting. This procedure should also be used at the web stiffener-tension flange intersection where bearing transfer is required.

(3) Diaphragms. Cracks in downstream girder flanges have occurred at the intersection with vertical diaphragms in existing vertical lift gates used at navigation locks. The intersecting welds combined with a category E detail provide a point of crack initiation. To avoid this situation, the diaphragm should not be connected to the girder flange. Rather, the diaphragm should be coped so that no contact is made. Because EM 1110-2-2105 requires that compression members

be considered for fatigue effects, the diaphragm should be coped around the compression flange as well.

(4) Intercostals. Avoid intersecting welds by using a chamfer or "rat hole" in the intercostal where it intersects with girder flanges or other intercostals. Intercostals running in two directions, as on the top damming surface of vertical lift gates used at navigation locks, should be placed on opposite sides of the skin plate or girder web. Not only will this avoid intersecting welds but will simplify construction as well.

(5) Tension ties. On tied arch vertical lift gates, a difficult situation exists at the connection of the tension tie to the compression arch. The problem is further complicated when the tension tie experiences a stress reversal. The case history for the Ice Harbor Navigation Lock downstream vertical lift gate (Appendix B) provides more information for designing arch tension ties to avoid fatigue.

c. Fracture control requirements. Fracture critical members (FCM's) are defined in EM 1110-2-2105. For vertical lift gates, FCM's may include downstream girder flanges and tensile downstream bracing members. For FCM's, the designer shall enforce controls on fabrication and inspection procedures to minimize initial defects and residual stresses and specify the minimum fracture toughness requirements. See EM 1110-2-2105 for more information on fracture control requirements. There have been many problems with FCM's of vertical lift gates used at navigation locks in the past. While most of the problems have involved fatigue (poor selection of connection geometry), they have been exacerbated by lack of a fracture control plan. Notchlike details of design or abrupt changes in shape cause stress concentrations. This becomes significant in members that are to be subjected to many loading cycles or sufficiently low service temperatures that ductile behavior and resistance to brittle fracture may be substantially impaired. Likewise, when severe impact loading, comparatively thick material, or severe multidirectional restraint is involved, more concern is warranted regarding the effect of notchlike details and stress concentrations. Therefore, members and connections of vertical lift gates shall strictly follow the provisions of AISC (1995), the provisions for welding FCM's provided in AWS D1.5-96 (American Welding Society (AWS) 1996a), and provisions described elsewhere in this manual concerning design, detailing, and fabrication for fatigue loading. The fracture control requirements for FCM's consist of specifying material toughness requirements, limiting the geometry of initial flaws, and selecting proper connection details.

(1) Toughness requirements. Material toughness requirements are specified in the form of minimum Charpy vee-notch (CVN) test values. A minimum CVN value is selected from Table 3-1, EM 1110-2-2105, based on expected service temperature, material thickness, and type of connection

to be used. The project specifications shall indicate the minimum CVN value required for FCM's of the specified gate material.

(2) Initial flaws. Part of the fracture control plan requires limiting initial flaws by imposing strict fabrication and inspection requirements. Specifications shall require qualification of welders and inspectors in accordance with AWS D1.5-96 (AWS 1996a). Initial flaws include nicks or gouges in base or weld material; any of the various weld discontinuities including incomplete fusion, inclusions, undercut, porosity, and cracks; and misalignment of members. Welds of FCM's shall be nondestructively tested. Discontinuities shall be noted and corrected.

(3) Connection details. The heat input due to welding can reduce the toughness properties of the base metal in the heat-affected zone. The toughness of base material is further affected in areas where the heat-affected zones from adjacent welds overlap. Care should be taken when connecting stiffeners or other members to FCM's to prevent overlap of heat-affected zones.

3-8. Material Selection

Proper selection of materials is important when considering the serviceability requirements, as well as the fatigue life of the gate. When fatigue is being taken into account, a high-strength, low-alloy steel may not be the most economical choice if the allowable stress range is low. As noted in the case history for Ice Harbor Vertical Lift Gate Replacement (Appendix B), all structural steel was American Society for Testing and Materials (ASTM) A572/A572M, Type 2, Grade 345 (50) (ASTM 1994a). Although the load cycles were high, the members and welded joints were capable of transferring higher allowable stresses. The deflection of members fabricated of high-strength low-alloy steel will always be more severe than if the member were of structural grade carbon steel. Materials listed in this section serve only as a guide and should not be considered as a complete listing of materials that may be used.

a. Structural steel. The gate body should be of a welding quality structural steel, either carbon or high-strength low-alloy as required by the design. Carbon steels include ASTM A36/A36M (ASTM 1996c), while high-strength, low-alloy steel should meet the requirements of ASTM A572/A572M (ASTM 1994a), ASTM A242/A242M (ASTM 1993) and A588/A588M (ASTM 1994b) weathering steel (atmospheric corrosion resistant, high-strength low-alloy steel) that is uncoated is not recommended for use in construction of vertical lift gates. Coated weathering steel may be warranted in certain conditions, where it can be economically justified. Protective coatings applied to weathering steel typically provide longer corrosion life than other steels. In

many cases high-strength low-alloy steels may be economical for the entire gate.

b. Stainless steel. Wheel axles should be fabricated from ASTM A564/A564M Type 630, referred to as 17-4 PH, Custom 450 (ASTM 1995). Embedded guides and seal plates should be fabricated from stainless steel type 304 or 410S. Seal bolts and cap screws should use type 304; 410 is not recommended. Use of a nitrogen enhanced stainless steel is recommended for nuts or cap screws covered in ASTM A193/A193M-96b Type B8N, B8NA, B8MN, or B8MNA, often referred to as Nitronic (ASTM 1996b). This provides better resistance to galling.

c. Cast steel. Lifting hooks, rollers, and lifting chain connections are normally fabricated of cast steel, using mild- to medium-strength carbon steel casting. For items that are subjected to higher stresses than medium-strength castings are capable of carrying, high-strength low-alloy steel castings may be used.

d. Forged steels. Dogging and link pins should be fabricated of carbon steel forgings rated for general industrial use. Forgings may be untreated or heat treated depending on the intended use and requirements.

e. Miscellaneous. Fixed wheels should be wrought steel. Rail heads and treads of wheels operating on crowned rails should be hardened to Brinell 325 (ASTM 1996e), minimum.

3-9. Weldments

All new gates use some form of welded fabrication. Because most of the fractures that have been found in vertical lift gates occur near or at welds, it is very important to select the proper weld material and the proper weld procedures.

a. Materials.

(1) Carbon and high-strength low-alloy steel. Use shielded metal arc welding (SMAW) or submerged arc welding (SAW) low-hydrogen electrodes (as applicable) or other weld processes that exclude air from the weld puddle.

(2) Stainless steel. Use low-carbon content weld consumables (0.03-0.04 percent) to help prevent intergranular corrosion. Intergranular corrosion occurs when a pronounced difference in reactivity exists between the grain boundaries and the remainder of the alloy. During welding, this difference is set up when chromium carbides form at the grain boundaries while heating the steel in the 480-760 °C (900-1400 °F) range. The grain-boundary is depleted in chromium and becomes anodic with respect to the surrounding alloy. Corrosion then occurs along the grain boundaries. Using

low-carbon content weld consumables such as E304L or E308L for stainless to stainless welding or E309L for stainless to mild steel welding can help prevent this. Welding stainless steel should follow the guides established in the current divisions of the Boiler and Pressure Vessel Code (American Society of Mechanical Engineers (ASME) 1995).

b. Fracture control. All factors that contribute to cracking should be taken into account in the design, fabrication, and field repair of vertical lift gates. Some vertical lift gates have experienced severe cracking problems where they were used in navigation locks. Cracks have progressed completely through the tension flange and into the web of horizontal girders in full-penetration welds, heat-affected zone of the welds, and in the base metal. The designer should follow the guidelines established in AWS D1.5-96 (AWS 1996a), AISC (1995), and ETL's 1110-2-346 and 1110-2-351 for proper detailing and design for fracture control. During initial fabrication, high joint restraint occurs when thick flange plates of the horizontal girders are connected with full-penetration welds to thick flange plates of the vertical end post. These thick plates become heat sinks that cause the weld to cool too quickly. The combination of this joint restraint and quick cooling causes high residual stress to remain in the joint. Since the gates are too large for normal stress relieving processes, this stress remains in the gate when it is put into service. The accumulative effect of residual stress, normal in-service stress, and fatigue stress can cause cracking. Other factors that can cause cracking include hydrogen embrittlement of the fusion zone through migration of hydrogen liberated from the weld metal, improper weld width-to-depth fusion ratio in the root pass, and stress risers such as notches or abrupt changes in shape. Items to control during fabrication that will reduce the possibility of cracking include the following:

(1) Hydrogen pickup. Toe cracks and under-bead cracks are usually hydrogen-induced cracks. Sources of hydrogen during welding are moisture in the air, moisture in the electrode coating, moisture in the joint, and contaminants on the surface of the base metal.

(2) Moisture in the air. Use SMAW low-hydrogen electrodes or other weld processes that exclude air from the weld puddle. Use proper storage and handling of low-hydrogen electrodes to avoid moisture pickup.

(3) Moisture in the joint. The base metal must be dry prior to welding. If preheating is not required, the joint should be heated sufficiently to drive off any moisture.

(4) Contaminants on the surface of the base metal. The base metal should be cleaned by power tool or brushoff blast followed by solvent cleaning 50 mm (2 in.) each side of the joint after the joint preparation has been completed and immediately prior to welding.

(5) Heat input.

(a) Preheat. Use preheat required by the code or calculated from the carbon equivalent derived from the base metal chemistry. Preheat retards the cooling rate, and thus prevents the formation of martensite.

(b) Welding heat. Controlling heat input lowers the shrinkage stresses and retards the cooling rate, which helps prevent excessive hardening in the heat-affected zone.

(c) Post heating. Slow cooling helps prevent shrinkage stresses. Insulated blankets or heat blankets placed over the completed welds will help retard the rate of cooling. Quenching the gate by placing it in service prior to slow cooling to ambient air temperature shall not be permitted.

(d) Bead shape. Deposit beads having a slightly convex surface and a width of a ratio of weld to depth of fusion of 1 to 1 minimum, to 1.4 to 1 maximum.

3-10. Design Details

a. Seals.

(1) General. Rubber is almost universally used for seals because of its ability to form a watertight contact against any reasonably smooth surface. The J-type seal mounted on either the upstream or downstream side of the gate is most suitable for vertical lift gates. It is not considered necessary to use cushion stock or an open hole in the bulb, either of which will add to the cost of the seal. Fabric reinforcement, which was used in years past, is not required. Fabric adds to the cost of the seals and has the disadvantages of shorter life and higher friction loads. Seals should be molded, not extruded, and selected based on availability. Seal types, sizes, and available molds are listed in catalogs of major rubber manufacturers who produce seals. For low and moderate head installations, the section most frequently used for side and top seals is the J type with a 45-mm (1-3/4-in.) bulb and a 14-mm (9/16-in.) stem with overall length up to 178 mm (7 in.). During gate operation, the seal does not add to hoisting friction because the pressure on both sides of the seal is the same. As the pressure downstream of the gate drops, the seal, under the influence of the head pressure, moves toward the seal plate.

(2) Design. To allow greater flexibility for the seal and allow it to deflect toward the seal plate, the stem should be attached to the gate on the outer edge by the clamp bars, and not toward the bulb. Seal mounting details should be carefully considered to prevent damage to the rubber under all conditions of operation. The side and top seals should be designed for a 6-mm (1/4-in.) preset space between seal and the sealing surface on the pier guide. This preset space should occur with no hydrostatic load on the gate and the bearing

shoes, wheels, or rollers bearing against the downstream guides. The design should prevent the seals from bearing on the guides when the gate is above the water passage in the upper portion of the slot. This will prevent excess friction and wear on the seal during operation of the gate. Care should be taken to provide support for the bulb so there is no possibility of water pressure rolling it. All top seals should be fluorocarbon-clad to help prevent rolling of the bulb during operation of the gate. The bottom rubber seal is normally a wedge seal that relies on the weight of the gate to provide the seal compression for sealing. Transitions from side seals to top, bottom, and intermediate seals should be made with molded corner pieces spliced to the main seal pieces at about 0.3 m (1 ft) from the corner. These special seal pieces should be as small as possible to minimize the cost of the molds. Sealing surfaces for rubber seals should be stainless steel or corrosion-resisting-clad steel. Seals can be mounted on the skin plate side or the flange plate side, oriented so that the water pressure is acting on the stem of the J seal increasing the contact pressure of the seal. The most common arrangement for emergency closure gates is to place the seal on the skin plate side. Placing the seal on the flange plate side creates a buoyant condition that will prevent the gate from submerging under its own weight or sealing properly due to lack of pressure on the bottom compression seal. This condition will cause out-of-plane bending on the web of the bottom girder. Typical seal details are provided in Plate 10.

(3) Material. Rubber hardness for all seals is normally 60 to 70 Shore Type A, Durometer Hardness (ASTM 1997a). For very low head gates, 3 m (10 ft) or less, a 50 durometer hardness may be used to provide greater flexibility and compression of the bulb on the seal plate. This will enhance the ability of the seal to prevent leaks. Seals should meet the physical characteristics in ASTM D395-89 (ASTM 1989), D412-97 (ASTM 1997b), D471-96 (ASTM 1996f), D572-88 (ASTM 1988), and D2240-97 (ASTM 1997a).

b. Wheels. For fixed-wheel gates, the end post may be a single girder supporting cantilevered wheels or a double girder with wheels mounted on pins bearing at both ends. The axle of the cantilevered wheel runs through the end post and to an interior diaphragm that transfers the reaction at the inner end of the axle. The portion of the axle on which the wheel is mounted is often turned about 3 mm (1/8 in.) eccentric with the portions that bear on the end post and inner diaphragm. This ensures that small inaccuracies in hole alignment may be compensated for by rotating the axles until all wheel treads are in line and then permanently securing the axles against further rotation. The tracks may be rails or flat bearing plates. When rails are used, the wheels are flanged to serve as guides, the tread is cylindrical, and the railhead is crowned to allow angular movement due to deflection of the gate. When a flat plate is used, the wheel tread is either cylindrical or crowned slightly, and independent guides are provided if required.

Crowned tracks or wheel treads limit the allowable bearing; hence, another method used to compensate for gate deflection is with cylindrical wheel treads operating on a flat track with self-aligning, anti-friction wheel bearings in the wheels. To limit the misalignment in bearings, mountings for self-aligning bearings should incorporate stops or guides. Allowable misalignments should be in accordance with recommendations of the bearing manufacturers. Closely spaced wheels mounted individually in the end girders require very accurate track alignment to prevent local overloads. It is sometimes advantageous to mount the wheels by pairs in trucks to increase the spacing between points of support on the end girder. If only two trucks are used at each end of each gate section, the loads may be determined by statics, as they are independent of the elastic properties of the gate, track, and pier concrete. The problem of overload due to inaccuracy in track surface has been partially overcome in some designs by mounting individual wheels on spring-backed bearing pedestals. However, this construction is complicated and expensive and is not advocated. Bronze sleeve wheel bearings may be satisfactory for light loads, but the friction developed under moderate and heavy loads may prevent operating the gate under head. For this case self-aligning antifriction bearings are used. For either sleeve or antifriction bearings it is essential that proper provision be made for lubrication and for sealing the parts against entrance of water and grit. Bearing seals are subject to variations of internal and external pressures resulting from variations of temperature and hydrostatic head, and are seldom watertight. Design of bearing enclosures and wheel mountings should include provisions to facilitate inspection and maintenance. Grease pipelines should be routed to all inaccessible submerged grease fittings. This will allow lubrication of the wheel bearings when the gate remains closed for long periods of time. The wheels, bearings, axles, and gate structure shall be designed for the maximum radial load, acting simultaneously with an assumed side thrust applied at the wheel tread at the point of radial load. The magnitude of the actual side thrust will depend largely on the flexibility of the wheel mounting and adjacent gate structure and the sliding friction developed between wheel tread and track by any tendency of the gate to move sideways while being raised or lowered under load. Assumed side thrusts from 10 to 33-1/3 percent of the radial load have been used.

c. Tracks. Tracks consist of stainless steel plates for flat wheels or rollers, or railroad or crane rails for flanged wheels. In either case, the track surface must be hardened to withstand the bearing pressures without excessive deformation. The plate or rail must be backed by a structural member to properly distribute the wheel or roller loads to the concrete pier. This structural member is usually a wide flange beam section with the plate welded to the beam flange. The track assembly member is adjusted into position in a blockout in the pier, anchored rigidly in place, with the concrete cast around it. Plate 11 depicts this type of arrangement. Rails are usually

attached to the structural support member with standard rail clips and corrosion-resisting steel bolts. Rail structural support members may be embedded in concrete and the rail attached later, or blockouts may be left for the entire assembly. If the structural support member is embedded, a means should be provided for adjusting the railhead into alignment. This may be done by closely spaced wedges between the rail and the beam flange. When the rail has been adjusted, the wedges are tack-welded in place. The structural support member should be designed to translate the maximum computed wheel loads, plus 100 percent for possible overload, from the track or rail supports to the concrete without exceeding permissible stresses for normal loads in either the beam or the concrete.

d. Guides. Structural steel guide members should be provided to limit the movement of the gate horizontally, either in the upstream or lateral direction. The maximum upstream movement may be determined by the allowable deflection of the seal, the depth of wheel flange, the clearance in the lifting or latching devices, or an established nominal clearance for

handling. The clearance in the upstream direction is usually from 6 mm (1/4 in.) to 10 mm (3/8 in.). Side clearance between the edge of the gate and the slot should allow for thermal expansion and contraction of the gate body, fabrication clearance in the lifting or latching mechanism, permissible deviation of center line of wheels or rollers from center line of track, and deflection of the seal, if mounted with sealing surface parallel to the pier. Accurate installation of the guides is accomplished by leaving blockouts in the structural concrete. Double-nutted anchor bolts are installed in the piers to allow for guide adjustment in two directions. After the guide steel has been accurately aligned, it is grouted in place using nonshrink grout. Sills should be wide steel flanges set in a blockout. Accurate adjustment to line and slope is accomplished with anchor bolts through the bottom flange, with nuts top and bottom. This also prevents movement while the nonshrink grout is cast in the blockout. The bearing surface of the top flange of the sill should be a corrosion-resistant steel or have a stainless steel plate welded to it.

Chapter 4 Spillway Crest Gates

4-1. General

Similar to navigation lock gates, spillway crest gates use a horizontal framing system. As with navigation lock gates, vertical framing systems are not structurally efficient and require special framing to accommodate roller guides for hoisting operations. Hence, vertical framing is not recommended for new vertical lift gates, except for replacement in kind. Most spillway crest gates use a fixed-wheel end support system. Tractor and slide gates have been used for spillway crest gates; however, their use is not very common for this type of application. Paragraph 2-2*b* describes the different arrangements of spillway crest gates. Much of the information regarding framing, loads, and load types provided in this chapter references information provided in Chapter 3. Only information unique to spillway crest gates is provided in this chapter.

4-2. Framing Systems

Horizontal girder framing is the most common type of framing system used for spillway crest gates. They may be framed with plate girders or rolled shapes. This type of framing system is described in paragraph 3-2*a*.

4-3. Load Types

The following load types are applicable to vertical lift gates used in navigation lock structures:

a. Hydrostatic. The hydrostatic load H_s shall be determined based on site-specific conditions that account for the differential between headwater and sill bearing at the spillway crest. Headwater is determined from reservoir regulation studies for the dam.

(1) For single-section gates, flow is under the gate. No consideration is given to water passing over the top of the gate. H_s represents hydrostatic head differential between headwater and the sill bearing at the spillway crest, and is represented in Figures 4-1 and 4-2. In addition, H_s acts as uplift on the bottom of the gate when passing flows through the spillway. The net uplift shall be determined from combined effects of downpull forces R .

(2) For multiple-section gates, consideration must be given to water passing over the top of the sections of the gate because the gate can be split to allow flow at various

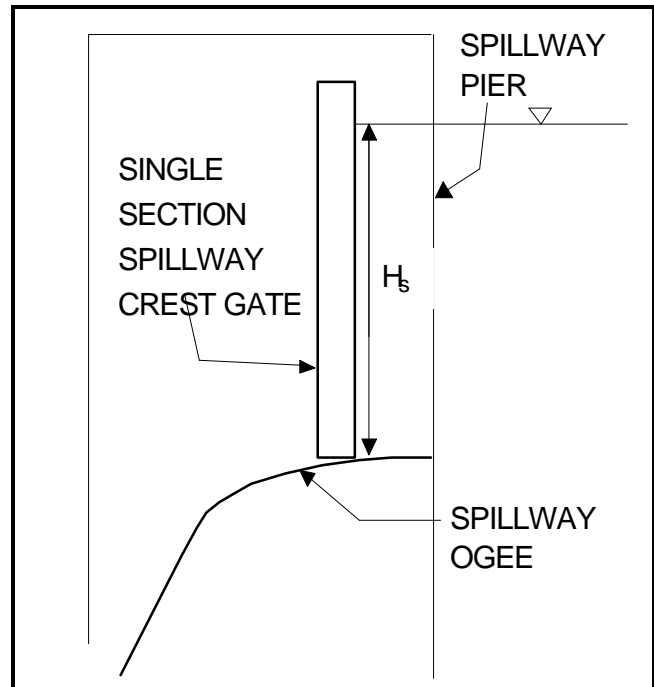

Figure 4-1. Single-section spillway crest gate

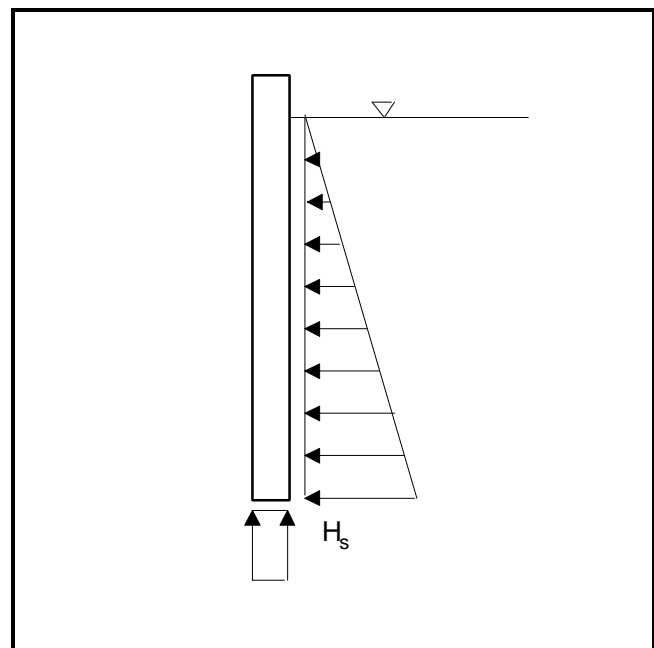

Figure 4-2. Single-section spillway crest gate, hydrostatic loading diagram

sections. For each section, H_s represents hydrostatic head differential between headwater and the bottom of each section, with the bottom section at the sill, bearing at the spillway crest. This is represented in Figures 4-3 and 4-4. These gates may

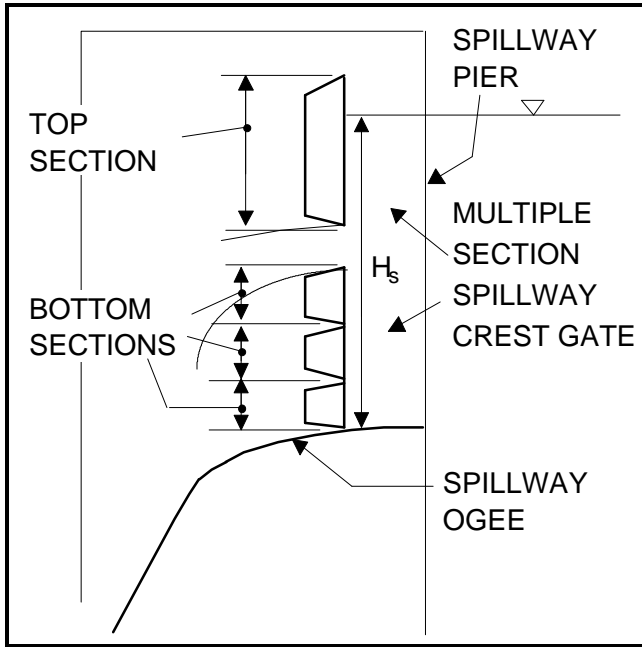

Figure 4-3. Multiple-section spillway crest gate

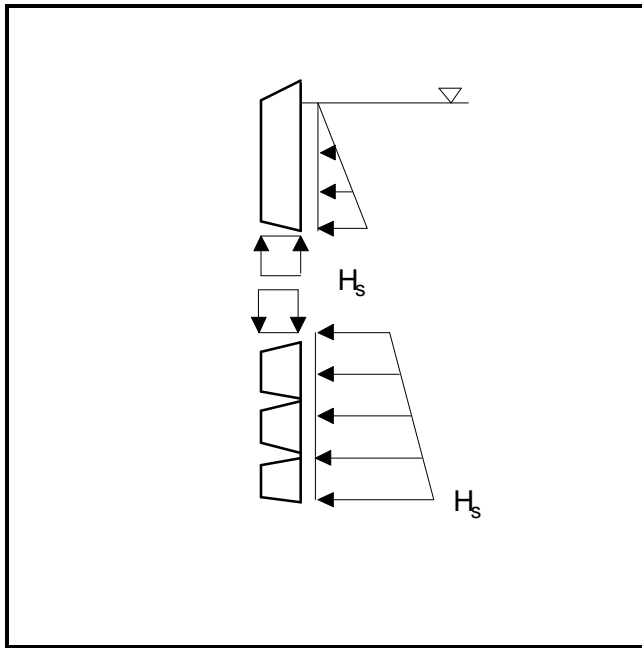

Figure 4-4. Multiple-section spillway crest gate, hydrostatic loading diagram, top and bottom sections split

be used as a single-section gate. For this condition, H_s will act as uplift on the bottom of the gate when flow is through the spillway. The net uplift shall be determined from combined effects of downpull forces R .

(3) For double-section gates, consideration must be given to flow over the top section. The amount of hydrostatic head flowing over the top section of the gate is determined from hydraulic studies and operational criteria for the reservoir. Operation of the bottom section should consider uplift (buoyant effects) on the bottom of the gate. H_s represents hydrostatic head differential between headwater and the bottom of both sections, with the bottom section at the sill, bearing at the spillway crest. This is represented in Figures 4-5 and 4-6. The net uplift shall be determined from combined effects of downpull forces R .

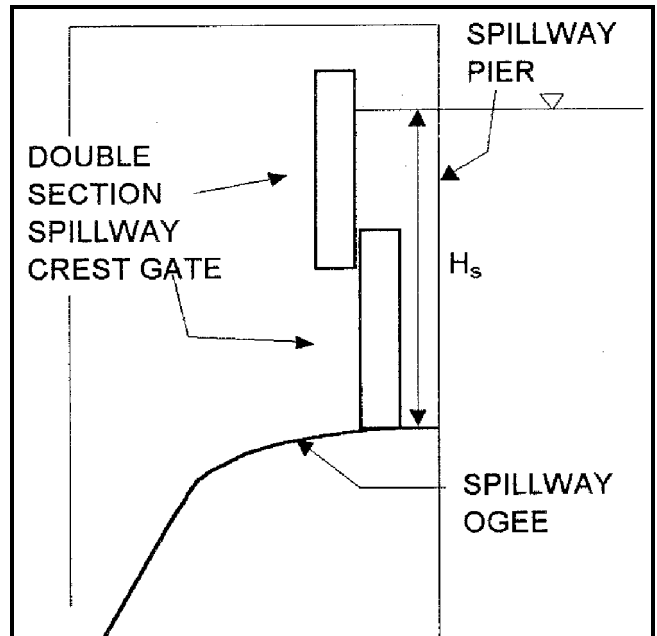

Figure 4-5. Double-section spillway crest gate

b. Hydrodynamic. The hydrodynamic loads H_d shall be determined based on site-specific conditions for vertical loads from water flowing over sections of spillway gates. The amount of head flowing over the sections of the gate is determined from hydraulic studies and operational criteria for the structure. H_d is applied similar to water flowing over leaves of submersible gates, shown in Figure 3-8.

c. Gravity. These loads shall be applied as described in paragraph 3-3c.

d. Operating equipment. Q is the maximum inertial load that can be exerted by the operating machinery. This shall consider the inertial effects of the deadweight, and in the case of double- or multiple-section gates, the inertial effects of the hydrodynamic load, H_d , ice C , and mud M , while using the gate for passing ice and debris.

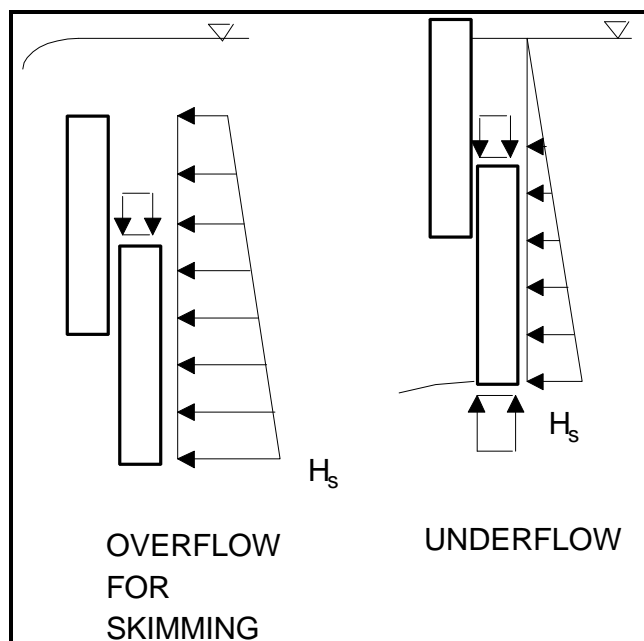

Figure 4-6. Double-section spillway crest gate, hydrostatic loading for overflow and underflow operation

e. Impact. Spillway crest gates are subject to debris or ice impact I of 5 kips/ft along the gate at the upstream water elevation. Impact loads need only be applied to main load-carrying members. For example, skin plate and intercostals need not be designed for impact loads.

f. Earthquake. These loads shall be applied as described in Paragraph 3-3f.

g. Downpull. Downpull forces R (sometimes referenced as downdrag) shall be determined based on flow conditions and the shape of the gate. These shall be determined by hydraulic studies or extrapolation of data from previous testing.

h. Wind loads. Wind loads shall be based on site-specific conditions. ANSI A.58.1/ASCE 7-95 (ANSI/ASCE 1995) may be used to determine wind pressures acting on the gate. Wind load shall be applied normal to the projected surface of the gate.

4-4. Load and Resistance Factor Design

a. Design guidance. Spillway crest vertical lift gates shall be designed using LRFD methods in accordance with EM 1110-2-2105. A synopsis of the methodology and general

guidance for use of LRFD for HSS is presented in EM 1110-2-2105 and will not be repeated here. Design strength factors shall conform to the requirements in EM 1110-2-2105.

b. Load cases and load factors. Lift gates shall have design strengths at all sections at least equal to the required strengths calculated for the factored loads and forces in the following load combinations. The most unfavorable effect may occur when one or more of the loads in a particular load combination is equal to zero. For each load combination the gate should be considered supported on either its fixed supports or by the hoisting equipment. For Equation 4-1, Q or R should be taken as zero when resting on its fixed supports.

$$1.2D + 1.6(C + M) + (1.3W \text{ or } 1.2 Q \text{ or } 1.0 R) \quad (4-1)$$

$$1.0D + 1.0(C + M + H_d) + 1.2Q \quad (4-2)$$

$$1.2D + 1.4 H_s + kI \quad (4-3)$$

where

$$k = 1.0 \text{ for debris with no ice and } k = 1.6 \text{ for ice}$$

$$1.2D + 1.2 H_s + 1.6 H_d \quad (4-4)$$

$$1.2D + 1.2H_s + 1.0E \quad (4-5)$$

where

D = deadweight load of the gate

C = weight of ice

M = weight of mud or debris

W = wind load acting on the exposed portion of the gate

Q = maximum inertial effects of machinery forces

R = downpull forces

H_d = hydrodynamic head due to waves or flow over gate leaves

H_s = hydrostatic load due to differential head

I = lateral impact forces from ice or debris

E = lateral seismic forces from adjacent water

4-5. Commentary on Loads and Load Factors

a. Loads.

(1) Hydrostatic. The loadings in Figures 4-1 to 4-6 represent the gate seals on the upstream face. This would be the general arrangement for this type of gate.

(2) Hydrodynamic. The total amount of head overtopping the sections of a multiple-section and double-section gate shall be determined by investigation of river hydraulics and operational criteria. For gate sections that are replacing old gates in the same structure, H_d shall be determined by existing operational data or conditions. Because loads from ice or debris will be greater than wave forces, loads resulting from wave forces may be neglected.

(3) Gravity. Ice and silt or mud vary based on site-specific information. Data or observations for replacement of existing gates may be used to determine C or M . Usually the skin plate for a spillway crest gate is located on the upstream side, which prevents silt from building up on the girders of the gate. Hence mud is not a contributing factor. Ice can build up on the gate and contribute significant forces, depending on the regional and ambient conditions.

(4) Operating equipment. Coordination between the structural and mechanical engineers is required to determine the operating equipment loading. The mechanical engineer will need gate deadweight D and hydrodynamic load H_d , ice C , mud M , and downpull R to determine operating equipment requirements, including inertial effects.

(5) Impact. Impact values are taken from EM 1110-2-2702. For gates used in extreme weather conditions, further information for ice loadings may be obtained from EM 1110-2-1612.

(6) Earthquake. See discussion in paragraph 3-5a(6).

(7) Downpull. Downpull force on a gate is the result of a reduction of pressure on the bottom of the gate from the static head, or may be viewed as a reduction in upthrust or reduction in buoyancy. These forces contribute to the hoisting requirements as well as the vertical load capacity of the gate. Factors that affect the amount of downpull include the location of the gate seals (upstream or downstream), gate seal friction, upward thrust component due to energy head acting on the bottom of the gate, shape of the bottom of the gate, and flow over the top of the gate. EM 1110-2-1602 and its referenced publications may be used to determine these loads acting on the gate. Other published data for methods of determining the effect of downpull forces may be obtained from U.S. Army Corps of Engineers Hydraulic Design Criteria (HDC)

Sheets 320-2 to 320-2/3; Sagar and Tullis (1979); and Sagar (1977a, 1977b, 1977c).

(8) Wind. Wind loads for spillway crest gates will not control the main member sizes and overall geometry of the gate; however, wind will affect the stability of the gate while in the raised condition. For single-section gates, a significant portion of the gate will be raised out of the slot while passing flood flows. Depending on the hoisting arrangement and dogging positions of the gate, wind may cause stability problems with the gate. For the same reason, latching mechanisms for multiple-section gates that are raised above the gate slot should be designed to resist wind loads that induce shearing forces in the latch pins. These shearing forces are a result of rotation of the exposed portion of the gate relative to the position of the gate fixed in the slot.

b. Load cases and load factors. The commentary presented in paragraph 3-5(b) is applicable to spillway crest gates and is not repeated in this chapter except as noted. Equations 4-1 and 4-2 are intended to provide a check on maximum vertical loads to hoisting equipment and lifting anchor points. Wind will add forces to the gate and gate latching mechanism when raised in the slot. In this case $1.3W$ should be substituted in Equation 4-1 with Q or R taken as zero. The addition of $1.0R$ to Equation 4-1 is to account for downpull while W may cause shear forces in the gate latching mechanisms to be greater than either Q or R . The greater affect of W , Q , or R shall be applied. Equation 4-2 provides a check for vertical components of hydrodynamic forces H_d that act in conjunction with operating equipment loads Q . The constant k in Equation 4-3 accounts for either debris or ice. In mild climates, ice does not form; however, debris does add additional load to the gate. Therefore, two load factors are given, one for ice and one to account for debris in mild climates. Where conditions present loads from both ice and debris, the greater of the two shall be applied.

4-6. Serviceability Requirements

Serviceability requirements presented in paragraph 3.6 for navigation lock vertical lift gates are applicable to spillway crest vertical lift gates and are not repeated in this chapter.

4-7. Fatigue and Fracture Control

Fatigue and fracture control requirements for members and their connections are discussed in paragraph 3-7 for navigation lock vertical lift gates. For spillway crest vertical lift gates, the total number of loading cycles is based on the projected frequency of usage over the life of the gate. Generally, spillway gates are not operated as frequently as navigation lock gates; hence the fatigue may not play a significant role in the design of the gate. Where projected

usage of the gate is expected to place the members and connections into fatigue stress categories listed in AISC (1995), then the requirements in paragraph 3-7 for navigation lock vertical lift gates shall apply.

4-8. Material Selection

Material selection for spillway crest vertical lift gates shall follow the same guidelines established in paragraph 3.8. Framing methods and material types are similar to those of navigation lock vertical lift gates and are not repeated here.

4-9. Weldments

Weldments for spillway crest vertical lift gates shall follow the same guidelines established in paragraph 3.9. Welding

materials and procedures are similar to those of navigation lock vertical lift gates and are not repeated here.

4-10. Design Details

Design details for spillway crest vertical lift gates shall follow the same guidelines established in paragraph 3-10. Seals, wheels, tracks, guides, and fatigue and fracture details are similar to those of navigation lock vertical lift gates and are not repeated here.

Chapter 5 Outlet Gates

5-1. General

Similar to navigation lock gates, outlet gates use a horizontal framing system. As with navigation lock gates, vertical framing systems are not structurally efficient and require special framing to accommodate roller guides for hoisting operations. Hence, vertical framing is not recommended for new vertical lift gates, except for replacement in kind. Outlet gates use fixed wheel, tractor, and slide end support systems. Paragraph 2-2c describes the different uses of outlet gates. Much of the information regarding framing, loads, and load types provided in this chapter references information provided in Chapter 3. Only information unique to outlet gates is provided here.

5-2. Framing Systems

Horizontal girder framing is the most common type of framing system used for outlet gates. They may be framed with plate girders or rolled shapes. This type of framing system is described in paragraph 3-2a. The main difference in framing compared with that of spillway crest gates and navigation lock gates is that outlet gates require a sloping bottom or flat bottom with lip extension on the downstream side to reduce downpull forces while operating with water flow.

5-3. Load Types

The following load types are applicable to vertical lift gates used for outlet gates:

a. Hydrostatic. The hydrostatic load H_s shall be determined based on site-specific conditions that account for the differential between headwater and sill bearing at the invert. Headwater is determined from reservoir regulation studies for the dam. Figures 5-1 and 5-2 represent loading diagrams for hydrostatic loading of an outlet gate with a downstream seal with an upstream skin plate. Figures 5-3 and 5-4 represent loading diagrams for hydrostatic loading of an outlet gate with an upstream seal with an upstream skin plate.

b. Hydrodynamic. Hydrodynamic loads for outlet gates shall account for water hammer.

c. Gravity. These loads shall be applied as described in paragraph 3-3c.

d. Operating equipment. These loads shall be applied as described in paragraph 3-3d.

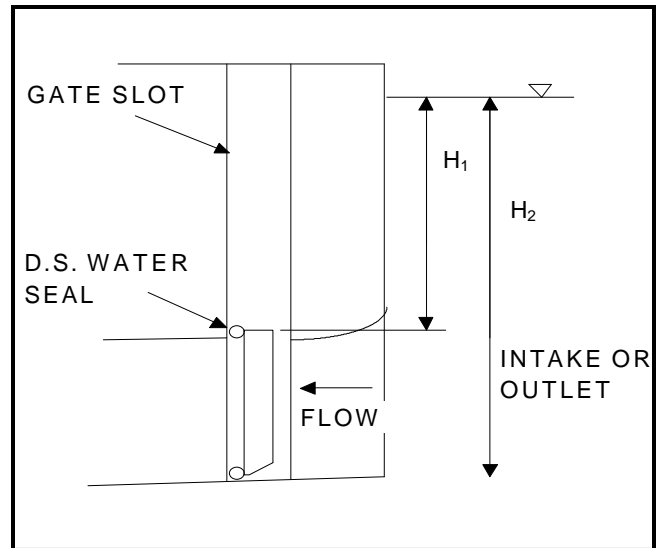

Figure 5-1. Outlet gate with downstream seal with an upstream skin plate

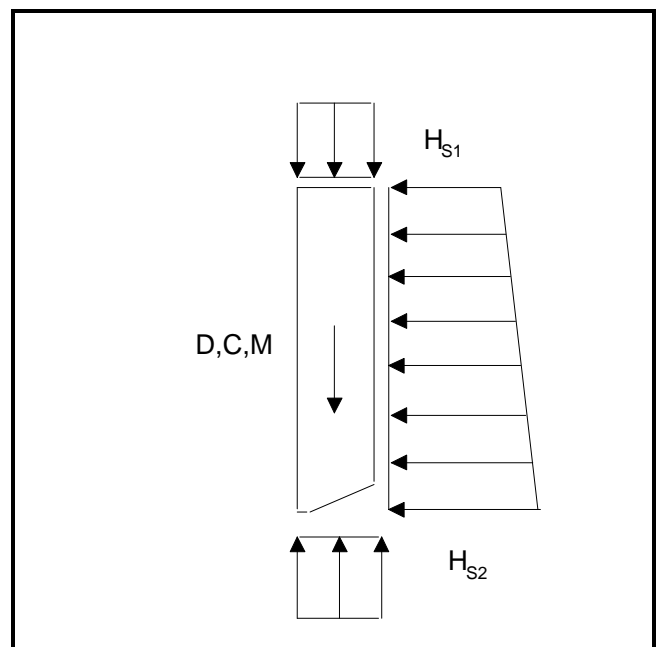

Figure 5-2. Outlet gate, hydrostatic loading, downstream seal with an upstream skin plate

e. Earthquake. These loads shall be applied as described in paragraph 3-3f.

f. Downpull. These loads shall be applied as described in paragraph 4-3g.

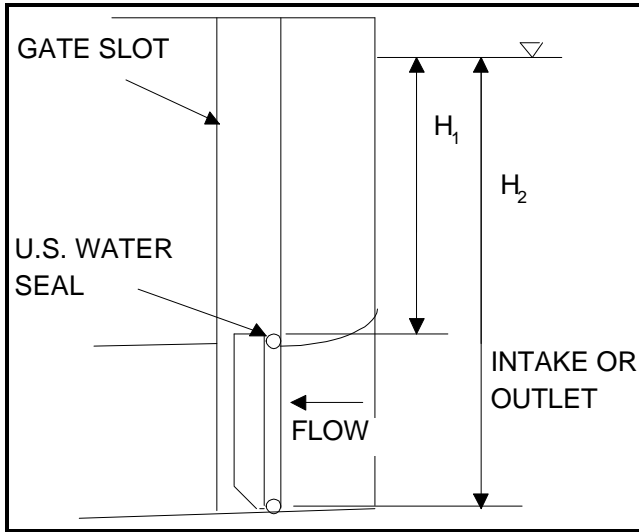

Figure 5-3. Outlet gate with upstream seal with an upstream skin plate

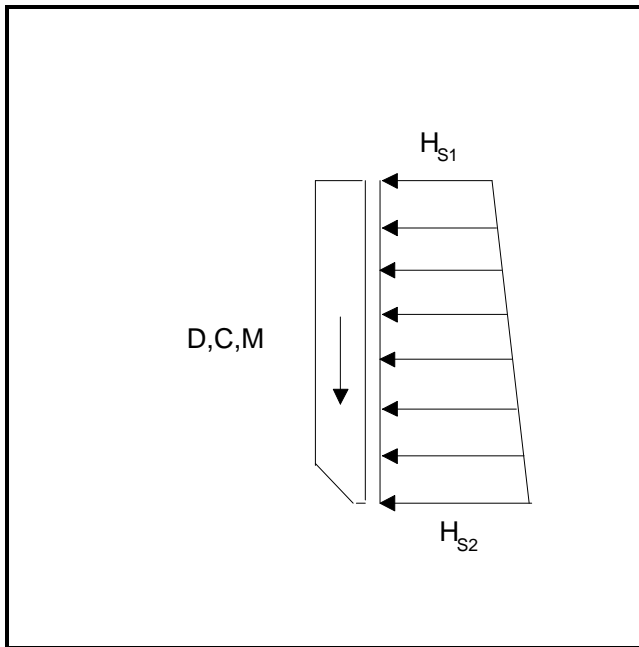

Figure 5-4. Outlet gate, hydrostatic loading, upstream seal with an upstream skin plate

5-4. Load and Resistance Factor Design

a. Design guidance. Outlet gates shall be designed using LRFD methods in accordance with EM 1110-2-2105. A brief synopsis of the methodology and general guidance for use of LRFD for HSS is presented in EM 1110-2-2105 and will not be repeated here. Design strength factors shall conform to the requirements in EM 1110-2-2105.

b. Load cases and load factors. Lift gates shall have design strengths at all sections at least equal to the required strengths calculated for the factored loads and forces in the following load combinations. The most unfavorable effect may occur when one or more of the loads in a particular load combination is equal to zero. For each load combination the gate should be considered supported on either its fixed supports or by the hoisting equipment. For Equation 5-1, Q or R should be taken as zero when resting on its fixed supports.

$$1.2D + 1.6(C + M) + (1.2Q \text{ or } 1.0R) \quad (5-1)$$

$$1.2D + 1.4H_s + 1.0H_d \quad (5-2)$$

$$1.2D + 1.2H_s + 1.0E \quad (5-3)$$

where

D = deadweight load of the gate

C = weight of ice

M = weight of mud or debris

Q = maximum inertial effects of machinery forces

R = downpull forces

H_s = hydrostatic load due to differential head

H_d = hydrodynamic load due to water hammer

E = lateral seismic forces from adjacent water

5-5. Commentary on Loads and Load Factors

a. Loads.

(1) Hydrostatic. Hydrostatic loads for outlet gates shall be as specified in paragraph 5-3*a*. Because there is only one operating leaf or section, no other special hydrostatic load conditions exist.

(2) Hydrodynamic. Hydrodynamic forces from flow either under or over the top of this type of gate are accounted for in downpull forces. Water hammer may develop depending on the type of application the gate will be subjected to. Variables associated with the magnitude of pressure change include the rate of change of the flow (closure time), the velocity of the water, and length of penstock or conduit. EM 1110-2-3001 provides information to determine the effects of water hammer and suggests that the hydraulic system be modeled using computer analysis for various operating conditions.

(3) Gravity. Gates used for outlet or emergency closures are normally stored in the gate slot. If they are stored out of the weather, ice will not be a consideration for loading to the gate. EM 1110-2-3001 provides further information on prevention of ice accumulation for powerhouse intakes. Because many emergency closure gates are stored below surface water, silt or mud will accumulate on the gate, the amount varying based on site-specific information. Data or observations for replacement of existing gates may be used to determine C or M .

(4) Operating equipment. Coordination between the structural and mechanical engineers is required to determine the operating equipment loading. The mechanical engineer will need gate deadweight D and hydrodynamic load H_d , ice C , mud M , and downpull R to determine operating equipment requirements, including inertial effects.

(5) Earthquake. See discussion in paragraph 3-5a(6).

(6) Downpull. Downpull forces are discussed in paragraph 4-5a(7). The same conditions apply for outlet gates, except the head on top of the gate is the static head in the gate well slot. All other references apply.

b. Load cases and load factors. The commentary presented in paragraph 3-5b is applicable to outlet gates and is not repeated in this chapter except as noted. The addition of $1.0R$ to Equation 5-1 is to account for downpull. It need not be included in combination with Q since Q accounts for hoisting forces, while downpull forces account for deployment of the gate. The greater of the two shall be applied in combination with $1.6(C + M)$. Water hammer associated with emergency closure is considered an extreme event and is given a load factor of $1.0H_d$ in Equation 5-2. Gate closing speeds should be designed to eliminate water hammer for normal operating conditions.

5-6. Serviceability Requirements

Serviceability requirements presented in paragraph 3-6 for navigation lock vertical lift gates are applicable to outlet gates and are not repeated in this chapter.

5-7. Fatigue and Fracture Control

Fatigue and fracture control requirements for members and their connections are discussed in paragraph 3-7 for navigation lock vertical lift gates. For outlet gates, the total number of loading cycles is based on the projected frequency of usage over the life of the gate. Generally, outlet gates are operated infrequently; hence the fatigue is not a contributing factor to the design of the gate. Where projected usage of the gate is expected to place the members and connections into fatigue stress categories listed in AISC (1995), then the requirements

in paragraph 3-7a for navigation lock vertical lift gates shall apply.

5-8. Material Selection

Material selection for outlet gates shall follow the same guidelines established in paragraph 3.8. In addition, intake gate guide tracks are normally fabricated from stainless steel type 304 and intake gate bearing tracks and roller chains from ASTM A564/A564M-95 (ASTM 1995) type 630 (17-4 PH; CUSTOM 450). Rollers and track require a Brinell hardness (ASTM 1996e) varying from 331 to 401 with pins and side bar having a Brinell hardness from 255 to 293.

5-9. Weldments

Weldments for outlet gates shall follow the same guidelines established in paragraph 3.9. Welding materials and procedures are similar to those for navigation lock vertical lift gates and are not repeated here.

5-10. Design Details

Design details for outlet gates shall follow the same guidelines established in paragraph 3-10. Seals, wheels, tracks, guides, and fatigue and fracturing detailing are similar to those for navigation lock vertical lift gates and are not repeated here except as noted for tractor roller gates. Because tractor roller gates are often used in high-head applications, additional considerations are required for seals and roller chain design.

For high-head installations, 60-m (200-ft) pressure-actuated seals are used. The designer is cautioned that a check should be made with the seal manufacturer before using a seal for a particular application. The pressure source is usually the head pressure of the reservoir itself. These seals are double-stem, center bulb type. To allow the seal to move toward the seal plate, the stem should be compressed only on the outer edge by the clamp bars and not toward the bulb. Observations of rubber seals indicate that the rubber has become extruded into the space between the clamp bar and the seal plate. To prevent this, brass-clad, or more recently, fluorocarbon-clad has been used. The fluorocarbon-clad has proven to be superior to the brass-clad because of its lower coefficient of friction (0.1) and greater flexibility and resiliency. The lower coefficient of friction reduces the load to hoisting equipment. The bottom rubber seal is normally a wedge seal that relies on the weight of the gate to provide the seal compression for sealing.

For tractor gates the roller trains are mounted on races supported either directly on the end girders or on weldments or castings bolted to the end girder webs. Rotation of the ends

EM 1110-2-2701
30 Nov 97

under load may cause excessive bearing pressures on the inside face of the rollers. This is corrected by articulating the roller race with the end girder. The tracks in the guide and roller races on the gate shall be machined to a surface roughness of 3.2 μm (125 microinches) and installed with a tolerance range

of -0 mm to +2.0 mm (-0 in. to +1/32 in.). Slight deviations from linearity will cause large roller overloads; therefore, rotation of the girder should limit deflection across the rollers to 0.5 mm (1/64 in.).

Chapter 6

Design Analysis and Detail Requirements

6-1. Gate Analysis Methods

a. General. It is the responsibility of the structural engineer to determine the appropriate level of analysis. There are many methods of analysis, both hand calculations and advanced computer programs, that will aid the engineer to obtain the optimum design of the gate. When using computer analyses, it is important for the structural engineer to understand the input parameters such as boundary conditions, material properties, and loading. Likewise, careful review of the output should show agreement with preliminary simplified calculations and simple statics checks.

b. Structural idealization. During analyses of vertical lift gates, consideration must be given to the methods of sealing, bearing, and hoisting to assure all loads are properly transferred to the guides, seals, plates, or rollers. Proper structural idealization of the boundary conditions will also ensure that the gate will perform as depicted in the structural model. For most vertical lift gates, two vertical sides and the top will bear against a downstream embedded bearing plate, with the bottom seal resting vertically on the bottom sill plate. For hydrostatic loads, the reaction components are orthogonal to the bearing face and are modeled as rollers with no resistance to rotation. Seal friction or plate bearing friction will ensure structural stability in the out-of-plane loading direction. In most cases where the gate rests on the sill, the bottom bearing surface should be modeled as having one vertical reaction component with the remaining degrees of freedom able to translate and rotate. Where the gate may be subjected to large changes in ambient conditions, restraint forces caused by friction should be examined to determine the magnitude of these forces that may induce additional stresses in the members and joints. This could lead to fatigue cracking problems if not properly addressed. These thermal forces would most likely occur in large navigation lock gates where the skin plate is subjected to cold water, while the other side is exposed to hot ambient conditions. In the case of the old downstream vertical lift gate at Ice Harbor Lock and Dam, restraint forces due to thermal differentials were studied. Analysis indicated that restraint forces increase stress from 206 to 310 MPa (30 to 45 ksi) to the main tension tie girders. This could play a significant role when the stress category for fatigue considerations is being determined.

c. Preliminary methods. Preliminary analyses are performed to determine the best framing method that will minimize the weight of the gate and still meet serviceability and physical restraints imposed by other structural features. The overall dimensions will be determined from the physical

requirements of the lock, intake, bulkhead slot, or spillway. These methods are generally employed during reconnaissance and feasibility level studies. Preliminary calculations should also consider fatigue and fracture control requirements discussed in Chapters 3, 4, and 5. Overhead lift gates used in navigation locks have been employed for high heads where it is more efficient to use tension tie arches or trusses. For these types of gates, the depth of the arch or truss combined with the horizontal spacing of the main structural framing will determine the size of the members. Submerged gates, spillway crest, and emergency closure gates generally use plate girders or wide flanges for the main load-carrying members. As in the case of the overhead lift gates, the skin plate thickness and spacing of the main load-carrying girders will determine the size of the members. Several trial analyses may be required to obtain optimal spacing of main framing members and skin plate thickness. Skin plates are discussed in further detail in paragraph 6-2a. It is beneficial to pattern trial framing based on existing structures; however, the designer is cautioned that most of the existing gates have not been designed using current fatigue criteria. In general, reductions in stress for fatigue will generally decrease girder spacing, require different connections and member shapes, or increase their size. Initial methods of analysis for this type of gate should use simple two-dimensional models. These methods include hand computations or simple two-dimensional frame analysis using readily available computer programs.

d. Detailed analyses. These include the analysis of the gate in sufficient detail to determine final member sizes and connections for the gate. Because structural analysis software has become widely accepted and more user friendly, can provide higher order analysis, and can be executed on most personal computers, it may be advantageous to perform a three-dimensional finite element analysis. This level of detail is up to the discretion of the designer. A three-dimensional analysis will reveal the overall structural response of main frame members in conjunction with secondary bracing, skin plates, intercostals, and diaphragms. This analysis will show contribution of secondary member forces to the total response of the structure. This was demonstrated in a three-dimensional analysis of the Ice Harbor Navigation Lock downstream vertical lift gate. Appendix B case histories provide more insight to the analysis of Ice Harbor as well as Lock and Dam 27. Attention should be given to the assembly of the model when meshing the skin plate to the framing members and, for the case of arched gates, the location of the intersection of the neutral axis of the main tension tie and the arch frame or truss. These will often be offset in the gate and will require special parameters in the finite element model. The same case exists for the connectivity of the skin plate to the upstream flange. In this case the plate and the structural member are modeled to join at a node. An offset parameter will be required to account for the eccentricity of the center of the plate to the neutral axis of the girder. One method to create the offset is to

use kinematic constraints (rigid links or master/slave combinations) for connectivity of the central plane of the plate to the neutral axis of the frame. This is illustrated in Figure 6.1. Another method is to apply specified joint offsets if the software has this capability. Intermediate vertical diaphragms or diagonal bracing used to separate girders or framing members can add considerable stiffness to the gate; therefore, they should be considered in the analysis. Three-dimensional finite element analyses, using commercially available software, have been performed for the gates at Ice Harbor Downstream Navigation Lock and Lock and Dam 27. Both model studies were initiated to determine the structural response of the gate when cracking occurred in the main framing members. Upon complete failure of the tension girder, W840x359, (WF 33x240) in Ice Harbor's old gate (Plate 1), it was demonstrated in the analysis that the skin plate and arch frame added considerable stiffness to the gate that transferred load to the adjacent arch frames. With a two-dimensional analysis, the arch and tension tie indicated only plane bending and axial stresses in the tension tie girders. A three-dimensional analysis revealed out-of-plane (weak axis) bending as a result of diagonal bracing lacing the downstream tension ties. In some cases, this added about 35 MPa (5 ksi) to the overall stress in the main tension tie. In the case of Lock and Dam 27, a three-dimensional finite element analysis was helpful in determining the distribution of vertical loads between the skin plate and the downstream bracing, and thus the out-of-plane loads to the downstream girder flanges.

6-2. Component Design and Detailing

a. Skin plate. The skin plate can be welded directly to the upstream or downstream edge of the main horizontal

framing member with continuous fillet welds and act as part or all of the flange, or be welded to the flange of a plate girder and used in combination. Design of the skin plate involves consideration of its function as a part of the girder flange as well as that of a load-carrying member transferring the water pressure to the girders. The latter function may be accomplished by action of the skin plate as a vertical continuous beam with reactions at the girder center lines, or as a number of rectangular panels with two opposite edges supported by adjacent girders and the other two edges supported by adjacent vertical diaphragms framing between the girders. Reference EM 1110-2-2105 for skin plate design criteria. Skin plates may be of uniform thickness for each gate section with little waste of material since the girder spacing and plate span decrease as the water pressure increases. Skin plate splices should be made in areas of low stress with full penetration welds and inspected by radiographic or ultrasonic inspection. It is not considered necessary to add an allowance for corrosion to the designed thickness of skin plate. Smaller vertical lift gates can be removed for maintenance and painting; however, with improvements in paint systems, this requirement is no longer necessary.

b. Plate girders. Plate girder arrangements consist of a horizontal web plate with a skin plate on one side and flange plate on the other side framing into end posts. The girder spacing and flange width should assure that there is adequate space between flanges to allow access between girders for fabrication, painting, anode installation, inspection, and maintenance. The clear span of the girders is the distance between the center line of the bearing supports on either side of the gate. They are designed as simply supported members using the strength requirements in EM 1110-2-2105.

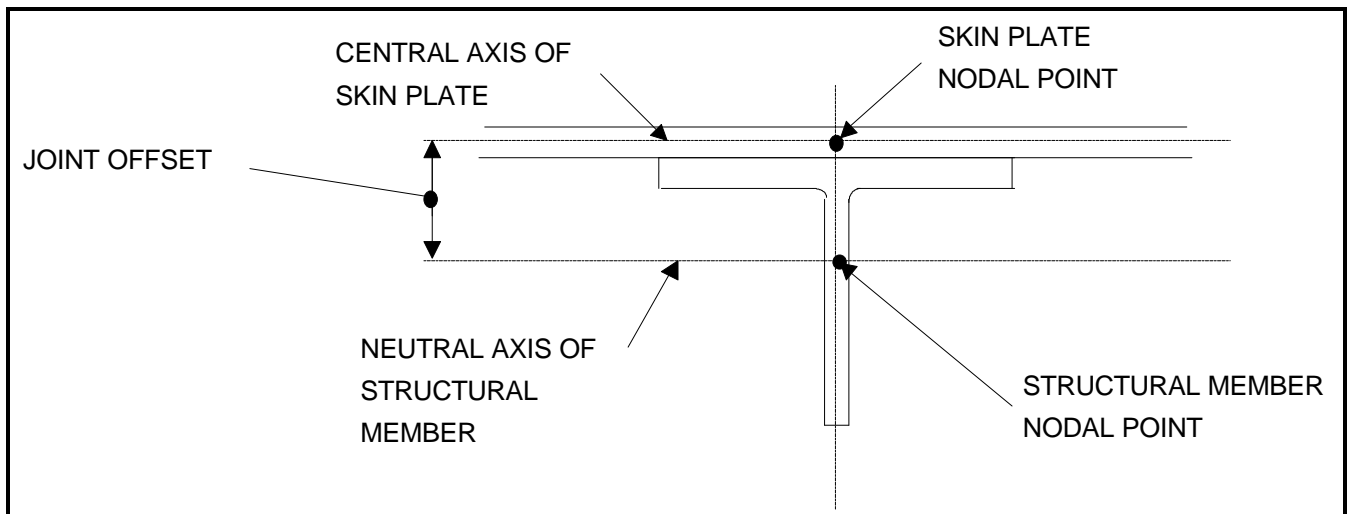

Figure 6-1. Joint offsets for plate to girder mesh

Transverse stiffeners shall be designed in accordance with the requirements specified in AISC (1995). Longitudinal stiffeners, if used, shall be proportioned in accordance with the appropriate paragraphs in AASHTO (1996).

c. Trusses. The design of the truss requires that secondary stresses be minimized by assuring that the connection of truss members coincides with the centroidal axis of the members at the joint. The effects of secondary stresses that are caused by stiffness, restrained joints, and excessive deflections require correct evaluation and proper detailing to increase the fatigue life of the structure. Combined compression plus bending will occur when the compression chords are welded to the skin plate or the skin plate is used in combination with the compression chord. A reduction of negative moments in the truss is not recommended for continuous members. To determine the stability of the tension chords under stress reversal, loads acting on the reverse side shall be investigated. These may include wave runup, wind loads, or in the case of hurricane or tide gates, effects of reverse hydrostatic loads. Vertical bracing, distributing loads from the downstream chord, helps distribute the horizontal truss loads and support the vertical loads applied to the gate or throughout its movement. Recent studies reveal considerable stiffness in the vertical trusses that can create adverse stress conditions in the gate framing. Therefore, care should be used when analyzing and accounting for attraction of additional stiffness at the joints. The degree of fixity will determine the appropriate value of equivalent pin ended member of length KL as specified by the AISC (1995) for compression members. Deflections should be investigated to determine the effects of tolerances for the gate slot depth and width, as well as upstream or downstream clearances. Camber should be considered where live load deflection will cause tolerance problems.

d. Tied arch members. Design of the main tension tie requires the consideration of weak axis bending and torsion. Mud and ice resting on the web as well diagonal and vertical bracing make a significant contribution to this type of loading. In addition, emphasis should be given to the load path from secondary bracing. The secondary bracing may have a direct load path to the tension ties, which will induce weak axis

bending in combination with tension from the arch. Proper detailing of fracture critical connections to the tension tie is important to the service life of the gate. The applicable sections of the AISC (1995) steel manual shall be used for determining the effects of members under tension, torsion, and other combined forces. Where the girder webs are resting horizontally, drainage holes need to be sized and spaced accordingly to eliminate weak axis bending, to reduce the weight to the operating machinery, and to prevent maintenance problems.

e. Intercostals. Intercostals span between main horizontal framing members to stiffen the skin plate and take advantage of two-way plate bending action. Their use may not be required where main framing members are closely spaced. Intercostals may be single bar or plate, or angles of unequal leg sizes. Load distribution and design rationale for intercostals are presented in EM 1110-2-2105 and shall be used for vertical lift gates. Proper detailing should consider the fracture and fatigue life of the intercostals and their contribution to the skin plates, girder flanges, and webs.

f. Diaphragms. Vertical diaphragms transfer horizontal loads to the girders and cause the gate to deflect more uniformly. They also support and distribute vertical loads. Hoisting equipment is located along the line of diaphragms to transfer the vertical hoisting loads.

g. End posts, end bearing. The end bearing transfers the girder reactions from bearing shoes, wheels, and rollers to bearing plates or tracks on the pier. Horizontal girders transfer load through shear into end posts. End posts may be single girders supporting cantilevered wheels or rollers, or double girders with wheels mounted on pins bearing on both sides. Two types of bearing conditions can occur. One type provides bearing directly from the rollers as a series of point loads or from wheels as a single point load. The other type relies on a bearing shoe mounted to the gate to transfer loads to the bearing plate. This type requires a recess in the guides to prevent the wheels from transferring hydrostatic load, allowing the bearing shoe to transfer hydrostatic load to the bearing plate. This becomes advantageous when loads are too great for wheel point bearing transfer, as with navigation lock gates.

Chapter 7 Operating Equipment

7-1. General

The operating equipment for vertical lift gates is referenced here for general description. Design criteria for operating machinery will be provided in EM 1110-2-2610 to be published. Interim guidance is provided by contacting CECW-E and in EM 1110-2-2703 and EM 1110-2-4205.

7-2. Types of Hoists

Vertical lift gates use hydraulic or wire rope hoist systems. Wire rope hoists are used for spillway crest, outlet, and navigation lock gates. They are more suitable for gates that have deep submergence requirements, applications that do not allow portions of hydraulic cylinders above the deck (shallow settings), or when hoisting loads are too large and economics makes hydraulic cylinders impractical, as in vertical lift gates in navigation locks.

a. Wire rope hoists. Wire rope hoists consist of drums and a system of sheaves and blocks that are driven through a motor and arrangement of shafts, speed reducers, and spur or helical gears. Motors may be electric or hydraulic driven. It is common to provide two speeds to permit lowering at approximately twice the raising rate. The hoisting equipment is normally located next to the gate or slot with controls located in the control room, governor control cabinets, or next to the navigation lock gate depending on the gate and its intended use.

(1) Bull wheels. Bull wheels are used in overhead lift gates as a friction drive for hoisting the gate. The bull wheel, motor, and gearing system are located in a tower, high enough to raise the gate to its full and open position. The wire ropes wrap over the top of the bull wheel in grooves, with one side of the wire ropes connected to the gate and the other end to a counterweight. The motor and gear system provide the mechanical effort required to hoist the gate. This type of drum system is advantageous when the hoisting loads are large.

(2) Counterweights. These are used mainly in overhead type gates to offset the dead load of the gate to minimize the hoisting effort. The weight of the vertical lift gate will determine the mass of the counterweight required. It should be designed to compensate for adjustment of its mass to calibrate it with the weight of the gate once the system is in place. It is normal to have the gate/counterweight slightly unbalanced to allow the gate to close without power.

Another method for reducing the lifting effort is with a series of drums and sheaves, which are selected to give the mechanical advantage desired.

(3) Motors and gear boxes. Motors and gear boxes are the primary drives for wire rope hoist systems. Guidance for design may be obtained from sources referenced in paragraph 7-1. In addition, gear box components should follow the general guidance from the American Gear Manufacturers Association (AGMA) (1997).

(4) Wire ropes and sheaves. Selection, installation, maintenance, and inspection requirements for wire ropes and sheaves are contained in a draft EM, "Wire Rope Selection Criteria for Gate Operator Devices."

b. Hydraulic hoists. Hydraulic hoists normally consist of a single acting cylinder, pumps, reservoir, controls, and piping. More recent applications use telescoping cylinders to accommodate deep submergence gates. One or two cylinders may be used, the number of which is determined by the hoisting requirement and economics. The arrangement may include the cylinder to be supported above the gate with the gate and cylinder rod hanging from the piston or the cylinder recessed within the gate.

c. Roller chain hoists. Roller chain hoists consist of the lifting chain, drive and idler sprockets, drive machinery, and counterweight. The roller chains are located in recesses in the lock wall. Roller chains are flexible about an axis parallel to the lock center line and rigid about an axis perpendicular to the lock center line. Near the top of each recess the lifting chain is redirected by an idler sprocket to the drive sprocket, which is located in a recess below the top of the lock wall. From the drive sprocket the lifting chain continues to a second idler sprocket at the top of a counterweight chase. From the second idler sprocket the lifting chain extends vertically to the counterweight. The chain connection to the gate leaf is a three-dimensional gimbal, which allows rotation about the axes both parallel and perpendicular to the lock center line. Rotation of the connection point is allowed to prevent the lifting chain from being bent about its rigid axis when the gate leaf rotates. The connection points on the gate should be located at the end portions, at the approximate center of gravity of the gate. The drive machinery, located in a watertight recess at the top of the lock wall, consists of electric motor, open gear sets, and reducers. An advantage of roller chains is the positive drive connection over the drive sprocket, which does not require the space of a cable drum. Disadvantages include relative high cost of chains, frequent maintenance for lubrication, corrosion, and critical alignment required between sprockets.

7-3. Dogging Devices

Dogging devices (dogs) are usually mounted on grillages in recesses in the piers opposite the end posts of the gate. They pivot to permit retraction for clearance of the gate and are operated with push rods. Two or more dogs at each end of the gate slot may be required. The number and location of the dogs are determined by the operating requirements for discharge regulation and gate storage. The gate sections require dogging seats fabricated with structural or cast steel, welded or bolted on the end posts. The treads of cantilevered wheels may be used as dogging seats. Another type of dogging device consists of a cantilevered mild steel H-beam that retracts inside the gate at each end between the top and second girder web. The beam is located at the center of gravity of the gate in the upstream/downstream direction and runs through the end post to a reaction point at an interior diaphragm. The dogging beam is extended and retracted by using a bar as a

manual lever extending through a hole in the top web and into a row of holes in the top of the dogging beam. The cantilevered end of the beam rests on bearing pads recessed in the piers. This type of dogging device is preferred for powerhouse gates and bulkheads since they can also be dogged at the intake or draft tube deck level and there are no mechanical devices to be lubricated or maintained. Dogging devices should be designed to support twice the calculated dead load to allow for impact.

7-4. Lifting Beams

Lifting beams are normally provided for outlet gates and maintenance bulkheads. Because these gates are normally stored in a submerged condition, the lifting beam provides a latching and unlatching mechanism to lift the gate from the slot. Design guidance for lifting beams can be found in EM 1110-2-4205.

Chapter 8 Corrosion Control

8-1. General

Corrosion damage will occur over time and can impair structural and operational capacity of vertical lift gates. To minimize future structural problems and high maintenance and rehabilitation costs, resistance to corrosion must be considered in the design process. Vertical lift gates are subject primarily to localized corrosion (i.e., crevice corrosion or pitting corrosion), general atmospheric corrosion, or mechanically assisted corrosion. Brief theoretical discussions on corrosion are presented in EM 1110-2-3400, EM 1110-2-2704, ETL 1110-2-351, and CASE Steel Structures Task Group (1993). Prudent design and maintenance practices can minimize these types of corrosion. Corrosion of vertical lift gates is best controlled by application of protective coatings, but is also effectively controlled by proper selection of materials, cathodic protection, and proper design of details. The selection of corrosion protection alternatives is highly dependent on the particular environment in which the gate will function.

8-2. Coating Systems

Application of coating systems is the primary method of corrosion protection for vertical lift gates. Coating systems include alkyd enamel, vinyl, and epoxy paint systems. Thermal spraying (metallizing) should be considered when extreme abrasion is predicted or when local or state governments have restricted the use of volatile organic compounds. EM 1110-2-3400 provides detailed information on selection, application, and specifications of coating systems. An EM on thermal spraying is being developed. Construction Engineering Research Laboratories can also be contacted for additional information.

8-3. Cathodic Protection

Cathodic protection is often used in the more corrosive environments to supplement the paint coatings. Since corrosion is a continuing process of removing electrons from the steel, cathodic protection introduces a low current to counteract this effect. This essentially causes all parts of the structure to be cathodic. Cathodic protection is achieved by applying a direct current to the structure from some outside source. The direct current can be invoked either by impressed current or sacrificial anodes attached to the gate. Sacrificial magnesium anodes are often installed on gates used in fresh water when carbon and stainless steels are in contact with each other. For example, anodes would be used when a painted mild steel gate is in contact with stainless steel tracks and rollers and also in contact with the stainless steel guides through the bearing

shoes, rollers, or wheels. Unfavorable area differences such as a small anode (less noble mild steel 99 percent covered with paint) and a cathode many times larger (more noble stainless steel bare) will cause rapid development of pits at holidays and other imperfections in the paint coating. Magnesium, being less noble than either mild steel or stainless steel, becomes a sacrificial anode and will protect these flaws in the paint coating and also protect oxygen-deficient areas on the stainless steel. To provide adequate protection, anodes must be within 600 mm (24 in.) and in line of sight of the surface they are protecting. Plate 12 depicts typical anodes installed on an emergency gate.

8-4. Control Contamination

Metallic contamination of the metal surface can cause galvanic corrosion. Nonmetallic contamination on stainless steel can result in loss of passivity at the contamination sites or create oxygen concentration cells, which can cause pitting. Such components as stainless steel rollers, wheels, axles, track plates, seal plates, and guides should be passivated after fabrication with a nitric acid solution according to ASTM A380-96 (ASTM 1996a). During manufacturing, metals may acquire contamination from metal forming and machining operations. Avoidance of contamination, or the discovery and removal of prior contamination on metals, is critical at the construction site during erection or installation of the structure or equipment.

8-5. Design Details

Structural detailing has a significant impact on the susceptibility of the structure to corrosion. Structures should be detailed to avoid conditions that contribute to corrosion. The following items should be considered in the design process:

- a.* Structural members should be detailed such that all exposed portions of the structure can be properly painted or coated.
- b.* Provide drain holes to prevent entrapment of water. Locate extra large drain holes in areas where silt or sand may be trapped.
- c.* Avoid lap joints, but where used, seal weld the joint so that water cannot be trapped between the connected plates.
- d.* Grind slag, weld splatter, or any other deposits off the steel. These are areas that form crevices that can trap water.
- e.* Where dissimilar metals are in contact (generally carbon steel with either stainless steel or bronze), provide an electric insulator between the two metals and avoid large ratios of cathode (stainless steel) to anode (carbon steel) area.

f. Use continuous welds in lieu of bolts where possible with caution given to the effect of or susceptibility to fracture.

g. Break or grind sharp corners or edges to a minimum 1-mm radius to allow paint or coating to properly cover the surface.

h. Avoid designs with enclosed spaces. If such spaces cannot be avoided, make them large enough for maintenance work and painting, or provide cathodic protection. In some gates it may be possible to fill and seal the space with a noncorrosive liquid or solid. This technique has been used on tanks for floating fish entrance gates.

i. Consider using corrosion-resistant metal for areas that will be inaccessible for replacement.

j. If anodes are used, allow enough room for maintenance workers to replace them.

8-6. Commentary

Crevices, areas where water may pond, locations where dissimilar metals are in contact, and areas subject to erosion all contribute to corrosion. Specifying a uniform increase in member component thickness provides a structure with increased resistance to corrosion damage. However, this is not effective for localized corrosion; the total structural cost is

increased; and the increase in member resistance to tension, compression, and bending effects is not uniform. Before a protective coating is applied, steel must generally be sandblasted, so accessibility for sandblasting should be considered. A sandblasting hose generally cannot be bent sharper than a 600 mm (24 in.) diameter. In general, welded connections are more resistant to corrosion than bolted connections. In bolted connections, it is not possible to seal areas between plies. Water can penetrate the plies. Weld ends are particularly vulnerable to corrosion since these are areas where crevices exist. Where dissimilar metals are in contact, if the anode is large with respect to the cathode, corrosion will be slight. If only the carbon steel is painted and there is a small defect in the coating, the relative areas have a large ratio of cathode to anode area and rapid corrosion can occur. Therefore, it is best to paint both surfaces.

8-7. Safety

Corrosion may be the cause of catastrophic damage or loss of life due to failure of a gate or structural members of a gate. Particular attention must be applied to structural members that are inaccessible to inspection or accessible only for infrequent inspection. Of concern is fracture critical members. Prevention of corrosion failures shall be investigated during the design of the gate. Of major concern is placing human life at risk. Where corrosion failure will place human life at risk, the most current methods of corrosion control will be employed.

Chapter 9 Maintenance Considerations

9-1. General

Vertical lift gates should be designed with consideration given to maintenance and inspection. Most gates, if properly designed, will be capable of performing for the service life of the structure. Access is a critical item when gates are inspected. These inspections provide a check of critical areas and identify when and what kind of maintenance is required. For new projects, the design of the gate should consider where and how access will be provided. For navigation lock gates, ladders on the downstream side of the gate are normally provided. This allows inspection of girders visible to the downstream side of the gate. To inspect or replace the end wheels, a watertight access cover in the guide slot should be provided. Outlet gates and spillway crest gates can be inspected as the gate is pulled from the gate slot.

9-2. Bulkheads

Bulkheads are placed upstream or downstream of vertical lift gates to serve as temporary damming structures while vertical lift gates are inspected or removed for service. This requires a bulkhead slot a short distance upstream (or on the pressure side) of vertical lift gates. Bulkheads are similar in construction to emergency gates except they do not have rollers or wheels since they are installed and removed under balanced head. A valve in the bulkhead or a valve and piping in the pier are required to provide equalizing head between the bulkhead and gate for bulkhead removal.

9-3. Lubrication

Wheel gates have either bronze sleeve or antifriction bearings. It is essential that provisions be made for lubrication of these bearings to seal them against entrance of water and silt. Lubrication should be performed on a regular basis and whenever the wheel gates are brought out of the water to ensure the bearings are continually filled with grease. Grease pipelines should be made to inaccessible and submerged grease fittings for lubrication when gates remain closed for long periods of time. Some gates use automatic lubrication systems where the gate experiences high usage in an environment that causes rapid deterioration of the bearings. Manual lubrication fittings would require excessive manual maintenance. For overhead vertical lift gates used in navigation locks, the bearing shoes are continuous along the length of the end post. These shoes have been lubricated to reduce friction for hoisting and to allow for expansion or contraction while under hydrostatic load. These generally employ automatic lubrication systems along the length of the

shoes. Gates that use roller chains, as in tractor gates, are designed to operate without lubrication. Lubrication should be considered for dogging pivot points and push rod guides. Where they will be inaccessible, piping should be provided to allow lubrication at convenient locations.

9-4. Inspection

Engineering inspection requirements for gates are specified in ER 1110-2-8157. Gates that are otherwise inaccessible should be inspected whenever the gates are removed from the slots or while the water passage is out of service. During routine dam safety inspections, it may not be practical to inspect all gates for projects that have numerous spillway crest gates, outlet gates, or emergency intake gates (as in powerhouses). In those cases, checking one gate will give a good indication of the condition of the other gates. Where some gates have been rehabilitated more recently than others, one of the older gates and gates that are used more frequently should be checked. The downstream side of powerhouse emergency gates can also be inspected as part of the normal unit outage without being completely removed from the gate slot. The same can be accomplished with outlet gates. When the outlet tunnel is dewatered for inspection, a bulkhead should be placed to allow inspection of both sides of the outlet gate. Navigation lock gates should have a formal inspection during the dam safety inspections for the project. Periodic inspection reports should contain an inspection list of gates, dates, and condition of welds, coatings, fasteners, and wheels; and unusual conditions should be noted so that an overall condition history can be used to determine when scheduled maintenance should occur.

a. Structural inspection.

(1) End bearing. Since the main load transfer from the gate is through end bearing, that is the normal place for wear due to rotation from loading and unloading and expansion or contraction. Some vertical lift gates will transfer load through bearing shoes rather than rollers or wheels. The shoes may already be curved to handle end post rotation; however, excessive wear may cause portions of the end post or girders to bear directly on the guides. If this occurs, the guides will normally show excessive wear. Bolts or welds holding the bearing shoes in place should be inspected for damage or cracking. The only way to inspect this condition is to have the gate above the gate slot or recess.

(2) Structural and fracture critical members. Primary concern for structural members is their ability to safely carry the load throughout the life of the gate. Cracks developing on the tension side of flanges or plates are the primary cause of failure of members or gates. Prior to inspection of the gate, FCM's should be identified, with splices identified in the girder or skin plates. All splices should be carefully inspected for

cracks in welds, bolts, or rivets. Generally, fatigue will be the major contributor to cracking and failure of FCM's. Corrosion will also be a major contributor to a splice failure. If corrosion is occurring in welds or bolts, further investigation will be necessary to determine the extent of its effects and when repair should take place. Cracks in welds in FCM's shall be repaired in accordance with AWS D1.5 (AWS 1996a). Where a skin plate is on the downstream side of the gate, the skin plate becomes a tension member and the FCM. Splices in these skin plates become critical joints in highly stressed areas. These splices should be carefully examined for cracks. Often small cracks can be identified by rust forming along the hairline and are visible against a painted surface. Another major contributor to cracks forming on tension side flanges on navigation lock gates is where secondary bracing members have been welded to the flanges of horizontal members. Fatigue causes these cracks to propagate, some to complete failure of the member. During the inspection, the connection of secondary bracing to the flanges of the main horizontal girders should be carefully checked. Some gates have been designed with intermittent stitch welds for main horizontal girders to skin plates. Because they have not been seal welded, corrosion can occur between the flange and the skin plate. This condition should be noted.

(3) Joints. Critical joints for vertical lift gates occur in trussed or arched tension tied girders. Joints connecting the tension tie to the arch and truss members are subject to fatigue cracking. As with splices in FCM's, these joints should be carefully inspected for cracks forming along the weld or near the heat affected zone. These locations are usually identified as fracture critical and shall be repaired in accordance with AWS D1.5-96 (AWS 1996a).

(4) Welds and bolts. Older gates may have steel that contains material contents identified as ASTM A7. These steels have a higher carbon content than modern steels such as ASTM A36/A36M (ASTM 1996c). These gates were joined using rivets instead of welding. All bolts, rivets, cap screws, or other types of fasteners on the gate should be checked for tightness and corrosion. The presence of riveting is an indication that the older type of steel is present. Special attention should be given to corrosion, loose rivets, and the existence of small cracks beginning at rivet holes. This material can be joined by welding; however, the higher carbon content steel requires prequalifying welding procedures and a higher degree of inspection during the repair. Bolts require the same level inspection as rivets. Attention should be given to places where dissimilar materials are bolted or riveted together since galvanic corrosion occurs in these areas. All replacement bolts should be stainless steel and painted after installation. All repair of fracture critical welds shall follow welding procedures specified in AWS D1.5-96 (AWS 1996a). All other weld repairs should follow guidance specified in AWS D1.1-96 (AWS 1996b).

b. Other components.

(1) Coatings. Coatings commonly fail by pitting, blistering, flaking, peeling, and wear or abrasion. Discoloration of a coating is usually not serious, since the coating is still functional. EM 1110-2-3400 provides guidance for maintenance painting. The primary purposes for maintaining a good paint system for vertical lift gates are safety, extending the life of the gate, and protecting against unscheduled shutdowns. All visible areas of the gates including top, bottom, ends, skin plate, flange plates, and inside compartments should be checked. Often, the paint may not be peeled; however, significant rust and deterioration of steel may exist under the paint surface. The extent of the rust underneath will not be apparent unless the paint is peeled away to expose the damage. Further damage can be prevented if these areas are touched up, and not left for further deterioration.

(2) Anode condition. Anodes should be replaced when more than 50 percent is corroded. Anodes do not protect around corners. Thus, all anodes should be inspected and replaced if defective. Do not assume that adjacent anodes will perform the function of one that is inoperative. They will continue to function as long as magnesium is present and they are electrically connected to the gate by welding. All welds of anode core wire to the gate should be checked for soundness.

(3) Seal conditions. An inspection for leakage is one measure of the condition of seals. Seals are resistant to aging or weathering and usually suffer from abrasive wear or damage from misalignment when the gate is being raised or lowered. The inspection should include the face of the bulb that bears against the embedded seal plate to make sure that it has not been ground flat, and at the splice points to make sure they are still connected. Vulcanized factory splices rarely fail, but many gates have field splices made with a rubber cement, which do not develop the strength or durability of vulcanized splices. Many seals have a fluorocarbon strip vulcanized into the bearing face of the bulb to reduce sliding resistance. This should be checked to make sure it has not come loose. All steel supporting plates and bolts or flathead mounting screws should be inspected for tightness and soundness. Since bolts, cap screws, and nuts are stainless steel and the supporting plates are mild steel, inspect for corrosion caused by the dissimilar metals. Replace bolts with stainless steel type 304 (ASTM 1996d) and stainless steel nuts with NITRONIC 60 (ASTM 1996b). Paint all dissimilar metals with a submersible paint system after installation.

(4) Guide condition. Gate guides should be inspected during the same time the gate is being inspected. The most difficult inspection task is usually with pier guides in outlet type gates. They are submerged and require dewatering to inspect. Most guides are fabricated from stainless steel

exposed surfaces attached to embedded carbon steel bolts or framework. They are embedded in the concrete to tight tolerances and must transfer the gate load safely to the concrete structure. The seal plates must be straight and smooth so the rubber seals can provide a watertight fit when the gate is in place. The only part that is visible at most installations is stainless steel portions of the guides. Stainless steel should be passivated during fabrication prior to installation in the piers but may become active if the passive film is interrupted by conditions where oxygen is excluded. This occurs when the surface is contaminated with trash, silt, and mud, which causes corrosion due to adjacent active/passive areas. This differential aeration can be destructive to the 300 and 400 series stainless steels. The area where oxygen is excluded becomes the anode and the balance of the metal the cathode. Guides corrode at the highest rate at the bottom of the slot or at the splash zone when oxygen, velocity, and temperature combine under differential conditions. These areas should be closely examined during inspection. Some projects have high-pressure water jet systems for removing mud and silt from the bottom of the slot prior to each gate use. Systematic removal of floating debris will help prevent oxygen-starved areas at the water surface in the guide area at the splash zone. Embedded portions of the guides cause dissimilar metal contact, which can cause corrosion of the less noble metal. The exposed stainless steel is welded to embedded mild steel that contacts concrete reinforcing steel, which may come in contact with prestressed tendons, electrical conduits, fluid piping, and eventually the copper ground mat at the project. All are dissimilar metals in the presence of water since concrete is porous and saturated when submerged. This can cause

corrosion under the exposed guide surface. Byproducts of steel corrosion occupy a volume many times the volume of the steel. An indication that the embedded portions are corroding would be spalling or swelling concrete around the guides and rust staining of the concrete. If swelling causes misalignment of the guides, the gate will not bear or seal properly, necessitating repair or replacement.

(5) Roller chain or wheel condition. Thorough inspection of roller chains and wheels is important since the ability of outlet or spillway gates to operate under full head is dependent on the proper functioning of the roller chain or wheels. Tractor type gates use a continuous roller chain on each side to transfer reaction forces to the embedded bearing plates. Many older gates use rollers that were built from type 410 stainless (ASTM 1996d), which is susceptible to cracking while in service. All gate roller chains should be checked for cracks and missing parts, such as retaining rings or keepers. The chain should have rollers that are free to turn on their shafts and side link bars that rotate freely where they join the roller shaft. The complete chain should have clearance between it and the bottom of the roller track so that it is free to move on the track. Fixed-wheel type gates use a series of fixed-position wheels on both sides of the gate to transfer reaction forces. These wheels are mounted on an eccentric pin so they can be adjusted to a proper position to bear equally on the embedded tracks. The wheels are made of cast steel and are mounted on bushings that fit on stainless steel pins. The wheels should be inspected for damage and cracks, making sure they can still turn freely. If wheels have grease fittings, check to see that they have been maintained.

Appendix A References

ER 1110-2-1806

Earthquake Design and Evaluation of Civil Works Projects

ER 1110-2-8157

Responsibility for Hydraulic Steel Structures

EM 1110-2-1412

Storm Surge Analysis and Design Water Level Determinations

EM 1110-2-1414

Water Levels and Wave Heights for Coastal Engineering Design

EM 1110-2-1602

Hydraulic Design of Reservoir Outlet Works

EM 1110-2-1607

Tidal Hydraulics

EM 1110-2-1612

Ice Engineering

EM 1110-2-1614

Design of Coastal Revetments, Seawalls and Bulkheads

EM 1110-2-2105

Design of Hydraulic Steel Structures

EM 1110-2-2602

Planning and Design of Navigation Locks

EM 1110-2-2607

Planning and Design of Navigation Dams

EM 1110-2-2610

Design Criteria for Operating Machinery, FY98 Scheduled Publication

EM 1110-2-2702

Design of Spillway Tainter Gates

EM 1110-2-2703

Lock Gates and Operating Equipment

EM 1110-2-2704

Cathodic Protection of Civil Works Structures, FY98 Scheduled Publication

EM 1110-2-3001

Planning and Design of Hydroelectric Power Plant Structures

EM 1110-2-3400

Painting: New Construction and Maintenance

EM 1110-2-4205

Hydroelectric Power Plants Mechanical Design

ETL 1110-2-338

Barge Impact Analysis

ETL 1110-2-346

Structural Inspection and Evaluation of Existing Welded Lock Gates

ETL 1110-2-351

Structural Inspection and Evaluation of Existing Spillway Gates

American Association of State Highway and Transportation Officials 1996

American Association of State Highway and Transportation Officials. 1996. "Standard Specifications for Highway Bridges," AASHTO HB-16, 16th ed., Washington, DC.

American Gear Manufacturers Association 1997

American Gear Manufacturers Association. 1997. "AGMA Standards," Alexandria, VA 22314.

American Institute of Steel Construction 1995

American Institute of Steel Construction. 1995. "Specification for Structural Steel Buildings - Load and Resistance Factor Design Manuals," Vol I and II, 2nd ed., AISC MO20L, Chicago, IL.

American National Standards Institute/American Society of Civil Engineers 1995

American National Standards Institute/American Society of Civil Engineers. 1995. "Minimum Design Loads for Buildings and Other Structures," ANSI A.58.1/ASCE 7-95, New York.

American Society for Testing and Materials 1988

American Society for Testing and Materials. 1988. "Standard Test Method for Rubber - Deterioration by Heat and Oxygen," D572-88 (R 1994), Philadelphia, PA 19103.

American Society for Testing and Materials 1989

American Society for Testing and Materials. 1989. "Standard Test Method for Rubber Property - Compression Set," D395-89, Philadelphia, PA 19103.

American Society for Testing and Materials 1993

American Society for Testing and Materials. 1993. "Standard Specification for High-Strength Low-Alloy Structural Steel," A242/A242M-93A, Philadelphia, PA 19103.

American Society for Testing and Materials 1994a

American Society for Testing and Materials. 1994a. "Standard Specification for High-Strength Low-Alloy Columbian-Vanadium Structural Steel," A572/A572M, Philadelphia, PA 19103.

American Society for Testing and Materials 1994b

American Society for Testing and Materials. 1994b. "Standard Specification for High-Strength Low-Alloy Structural Steel with 50 ksi (345 Mpa) Minimum Yield Point to 4 in. (100 mm) Thick," A588/A588M-94, Philadelphia, PA 19103.

American Society for Testing and Materials 1995

American Society for Testing and Materials. 1995. "Standard Specification for Hot-Rolled and Cold-Finished Age-Hardening Stainless Steel Bars and Shapes," A564/A564M-95, Philadelphia, PA 19103.

American Society for Testing and Materials 1996a

American Society for Testing and Materials. 1996a. "Standard Practice for Cleaning, Descaling, and Passivation of Stainless Steel Parts, Equipment, and Systems," A380-96, Philadelphia, PA 19103.

American Society for Testing and Materials 1996b

American Society for Testing and Materials. 1996b. "Standard Specification for Alloy-Steel and Stainless Steel Bolting Materials for High-Temperature Service," A193/ A193M-96b, Philadelphia, PA 19103.

American Society for Testing and Materials 1996c

American Society for Testing and Materials. 1996c. "Standard Specification for Carbon Structural Steel," A36/A36M, Philadelphia, PA 19103.

American Society for Testing and Materials 1996d

American Society for Testing and Materials. 1996d. "Standard Specification for Stainless Steel Bars and Shapes," A276-96, Philadelphia, PA 19103.

American Society for Testing and Materials 1996e

American Society for Testing and Materials. 1996e. "Standard Test Method for Brinell Hardness of Metallic Materials," E10-96, Philadelphia, PA 19103.

American Society for Testing and Materials 1996f

American Society for Testing and Materials. 1996f. "Standard Test Method for Rubber Property - Effect of Liquids," D471-96, Philadelphia, PA 19103.

American Society for Testing and Materials 1997a

American Society for Testing and Materials. 1997a. "Standard Test Method for Rubber Property - Durometer Hardness," D2240-97, Philadelphia, PA 19103.

American Society for Testing and Materials 1997b

American Society for Testing and Materials. 1997b. "Standard Test Method for Vulcanized Rubber and Thermoplastic Rubbers and Thermoplastic Elastomers-Tension," D412-97, Philadelphia, PA 19103.

American Society of Mechanical Engineers 1995

American Society of Mechanical Engineers. 1995. "Boiler and Pressure Vessel Code," New York.

American Welding Society 1996a

American Welding Society. 1996a. "Bridge Welding Code," AWS D1.5-96, Miami, FL 33126.

American Welding Society 1996b

American Welding Society. 1996b. "Structural Welding Code - Steel," D1.1-96, Miami, FL 33126.

CASE Steel Structures Task Group 1993

CASE Steel Structures Task Group. 1993. "Steel Structures for Civil Works, General Considerations for Design and Rehabilitation," Technical Report ITL-93-2, U.S. Army Engineer Waterways Experiment Station, Vicksburg, MS.

Sagar 1977a

Sagar, B. T. A. 1977. "Downpull in High-head Gate Installations," Part I, *International Water Power Dam Construction* 29(3), 38-39.

Sagar 1977b

Sagar, B. T. A. 1977. "Downpull in High-head Gate Installations," Part II, *International Water Power Dam Construction* 29(4), 52-55.

Sagar 1977c

Sagar, B. T. A. 1977. "Downpull in High-head Gate Installations," Part III, *International Water Power Dam Construction* 29(5), 29-35.

Sagar and Tullis 1979

Sagar, B. T. A., and Tullis, J. P. 1979. "Downpull on Vertical Lift Gates," *International Water Power Dam Construction* 31(12), 35-41.

U.S. Army Corps of Engineers

U.S. Army Corps of Engineers, "Hydraulic Design Criteria," prepared for Headquarters, U.S. Army Corps of Engineers, by U.S. Army Engineer Waterways Experiment Station, Vicksburg, MS, issued serially since 1952.

Appendix B Case Histories

Section I

Ice Harbor Lock and Dam, Downstream Navigation Lock Gate Replacement

B-1. Background

Ice Harbor Lock and Dam is located on river mile 9.7 on the Snake River, near Pasco, Washington. Placed in service in 1962, the navigation lock is 205 704 mm (675 ft) long and 26 213 mm (86 ft) wide. Gates in the lock consist of an upstream tainter gate and a downstream overhead vertical lift gate. This case history describes structural failures and replacement of the downstream overhead vertical lift gate.

B-2. Original Design and Construction

The overall size of the lift gate is 26 822 mm (88 ft) wide by 27 737 mm (91 ft) tall, and it weighs approximately 612 349 kg (675 tons). Normal operating static head on the gate ranges from 29 566 mm (97 ft) to 31 394 mm (103 ft). The gate consists of 18 welded tied arches spanning the navigation lock width, with the skin plate welded to the upstream face. Vertical spacing of the arches is approximately 1045 mm (3 ft 5 in.) at the bottom and increases to 2530 mm (8 ft 3 in.) at the top of the gate. Each tied arch has an upstream curved compression member composed of WT 460x223 (ST 18WF150) welded to the skin plate and a W 840x359 (33WF240) downstream straight tension tie. The downstream tension ties are laced with WT 180x22.5 (ST 7WF15) diagonal and vertical bracing. At the gate's center span and approximately 4570 mm (15 ft) from each end, a diaphragm plate is welded to the arch and tension tie the full height of the gate. Two lifting points are symmetrically placed at approximately 2605 mm (8 ft 6 in.) from the ends of the gate. The gate is operated by two hydraulic hoists, one on each side of the lock, located in concrete towers above the gate. Twelve 60-mm-(2-1/4-in.-) diameter wire ropes, connected on each side of the gate, wrap over a pinion-driven bull gear on a drum and connect to a counterweight that travels vertically in the tower and lock monolith. Plate 1, main text, represents framing of the existing gate.

B-3. Structural Failures

The first documented structural failures began in April 1980 when cracking occurred in the second tension tie from the bottom and adjacent tension ties through the fifth tie at each diaphragm connection. At the end diaphragms the cracks were present in the flange of the tie and entered the diaphragm plate, and in the center diaphragm the cracks propagated through

both flanges and into the web. There were no documented repair procedures; however, repairs consisted of welding cover plates over the cracks in the flanges. Cracks did not appear again until June 1992 when four large cracks were observed and later repaired near the bottom of the gate, at the vee, the intersection of the tension tie girder, and the upstream arch compression member. From 1980 to 1992, the only other incidences of repairs were the the hoisting drum bearings, gear boxes, shafts and hydraulic units in 1989, and in 1991 replacement of guide roller with a compressible shoe. After new cracking developed in 1992, additional cracks were found in August 1993, some located at intersections of diagonals and tension tie girders, others at the vee. Figures B-1 and B-2 represent the typical location of the cracks where holes were recommended for drilling to stop the crack propagation. All were in the lower part of the gate. Because project forces could not keep up with the numerous cracks and crack growth between scheduled outages, a construction contract was required to finish the welding cracks during a scheduled 2-week outage in March 1994. Results from a three-dimensional finite element model of the gate indicated that the diagonal bracing contributed to out-of-plane bending in the tension tie girders, hence increasing the stress in the flanges. Therefore, part of the welding contract required that all diagonal and vertical bracing be removed, with all gouges and sharp edges ground smooth. After the welding was completed, cracking continued. By May 1994, 80 cracks had developed on the gate. Where bracing was removed, the cracking decreased; however, the incidence of cracking at the middle and upper levels of the tension tie girders increased. By June 1994 the total number of cracks increased to 130, almost all on the downstream flange of the tension tie girder. To provide a margin of safety to the integrity of the gate, gussets were added at the vee in the lower six tied arches to reduce high stress. They were designed to carry a portion of the arch load, bypassing a crack in the flange in the vee.

B-4. Corrective Actions

Throughout the time from June 1992 until the lock was placed out of service in December 1995 for replacement of the gate, repair of the numerous cracks continued. Some holes were drilled at the tip of the crack; however, this proved ineffective.

a. Investigations. Investigations were performed to determine the stress level in the member of the gate, metallurgical components of the steel, and any relationship between crushing of the side roller and induced high stresses.

(1) Stress levels. Stress levels in the gate were determined by a three-dimensional finite element model, with instrumentation used for verification and investigation of strains during hoisting, filling, and emptying operations. The first strain monitoring included investigation of strain in the tension ties through various cycles of gate operation. Strain

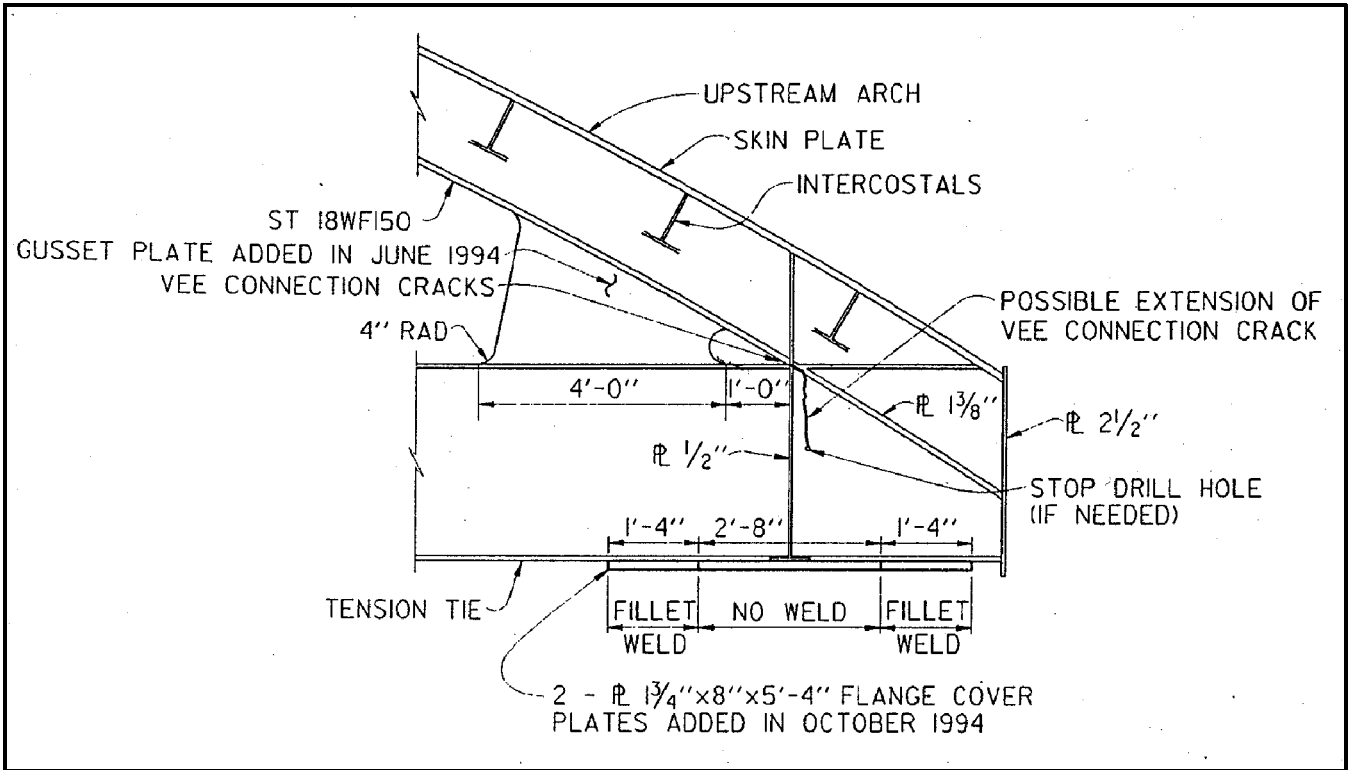

Figure B-1. Vee connection cracks and addition of gusset plate and flange cover plate for the existing gate

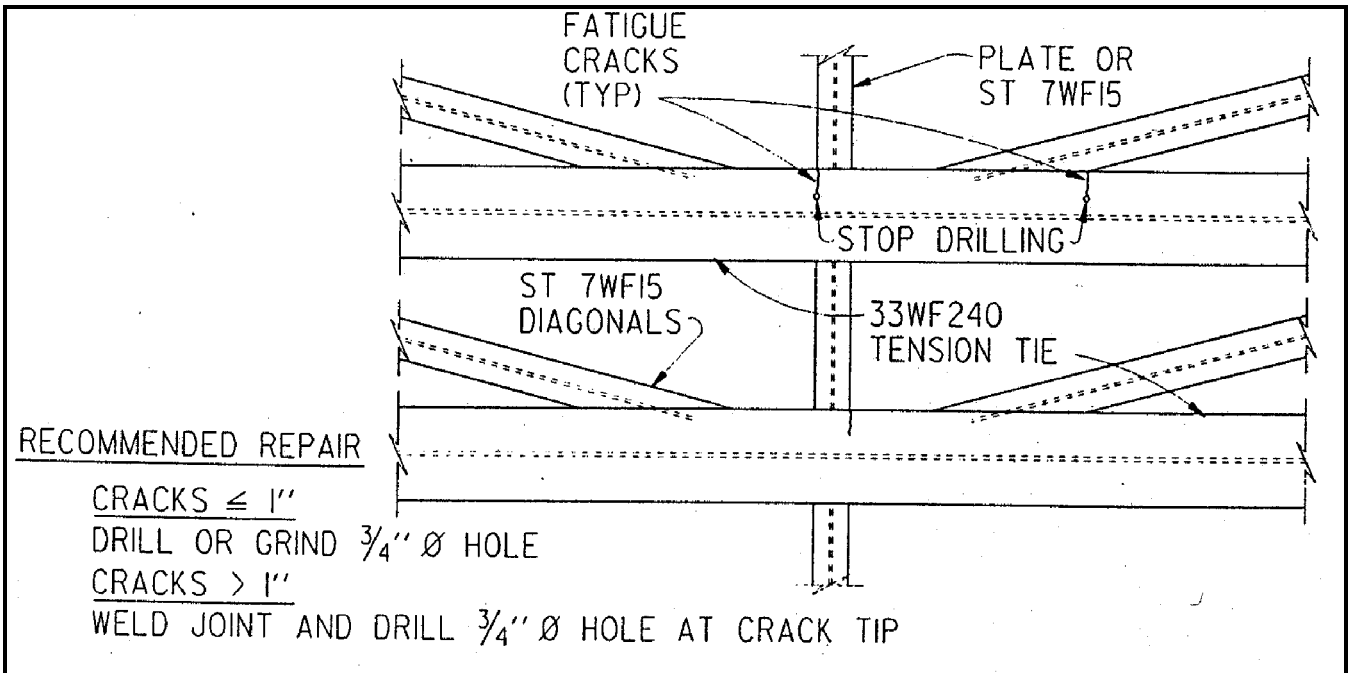

Figure B-2. Typical cracking located at downstream bracing to tension tie flange

monitoring revealed that during the gate's movement a very high stress in the lower tension ties occurred while the gate was raised a short distance. The largest stress was in excess of 372 MPa (54 ksi). No hydrostatic loads were placed on the gate during this operation. Because of this it was theorized that the gate motion was being restrained. During normal hydrostatic loading the stress range was 138 to 206 MPa (20 to 30 ksi), which was expected. To simulate the results that occurred during the gate's movement, various boundary restraints and hoisting loads were applied to the finite element model. The model could not simulate the loading indicated by the strain gauges, nor did pressure gauges in the hydraulic hoisting equipment indicate any overload due to restraint of the gate. To provide more conclusive data to verify computer analysis, and because side roller crushing could still be a factor in gate operation, a second series of strain monitoring was performed with a different contractor. These data indicated that stresses in the tension ties, diagonals, and compression arch were reasonable and similar to the results found in the computer model. No high stresses were reported during the raising and lowering of the gate. Therefore field instrumentation verified findings in the computer model.

(2) Metallurgical. Metallurgical analysis was performed on a coupon cut from the gate across an existing crack. Its chemical composition, hardness and microstructure were consistent with an ASTM A572/A572M, Type 2, Grade 345 (50), high-strength low-alloy steel (ASTM 1994a). This did not comply with the ASTM A242/A242M-93A (ASTM 1993) specified in the original contract. Results from Charpy V-notch tests did not indicate a problem related to low toughness of the steel. Examination of the fracture revealed an instantaneous overload tension failure. The primary failure mechanism was attributed to fatigue.

(3) Other investigations. In order to verify if the gate was restrained during raising and lowering, three separate tasks were performed. The first was an underwater camera inspection of the guide slot. This revealed a worn area on the north guide slot where the bearing shoe had rested. No irregularity existed in the guides. The second was a diver inspection, which involved taking measurements between guide slots, checking the width and depth of each slot, and visually inspecting the guide slots and bottom sill. There were no significant findings. The final was a field survey of the gate. Surveyors gathered three-dimensional coordinate data of the four corners of the gate at various elevations to determine if the gate translated or rotated during its operation. There were no significant findings.

b. Findings of investigations. The tension tie girders experienced a significant amount of cracking on the upstream flange near the vee. Numerous cracks formed on the downstream flange at the diaphragm and downstream bracing. Virtually all cracks start at the tip of welded joints. The

frequency of cracking accelerated to a point that keeping the gate functional for lockages was becoming impossible. Factors contributing to the cracking included the following:

(1) The heat-affected zone at the vee created large residual stresses that may have led to crack development. The vee connection creates a high stress zone due to its geometry.

(2) The welded joints were typically in an AISC fatigue category E. Most of these joints experienced between 172- and 221-MPa (25- and 32-ksi) tensile stresses under hydrostatic loads. The gate experienced approximately 60,000 cycles over 30 years since placed in service. Many of the joints in the gate met or exceeded their expected fatigue life.

(3) The quality of the welds made during the original fabrication were suspect.

(4) Undercutting, backing bars left in place, improper weld rods, and quenching hot steel were typical procedures used in repairs before 1992.

(5) The downstream diagonal bracing members contributed to secondary stresses. These were induced by temperature variations within the gate and residual forces created by frequent welding.

(6) There was no conclusive evidence that the gate was being restrained during raising and lowering.

B-5. Design and Construction of New Gate

All of the findings identified during the investigation of the existing gate were accounted for in the design of the new gate. The material, type of joints and gate configuration, weldments, fabrication, and installation contributed to the new design. Of major consideration was the type of joints as they relate to fatigue. AISC category E was avoided at all costs. Several gate configurations were considered for the replacement, including a miter gate. The miter gate was dropped from consideration due to the extreme cost differential to modify the lock monoliths. Framing options included tied arches, bowstring trusses, and plate girders. The tied arch was the most economical and the simplest to fabricate and was selected for design. Plate 2, main text, represents configuration of the replacement gate.

a. Design and structural configuration. Considered in the preliminary design was the type of connections, particularly revising the vee to a radius, to eliminate high stress risers at the connection of the arch to the tension tie. The preliminary design phase was used to develop connections and construction methods that would eliminate connections in high fatigue categories. By using a flat plate for the tension tie, rather than

a rolled or plate girder, and providing a continuous plate with a radius at the inside corner, category E connections could be avoided. Figure B-3 represents the structural configuration for connection of the compression arch to the tension tie. Preliminary member sizing was performed using hand calculations. Final design was performed using a three-dimensional finite element analysis. A refined model of the connection of arch to tension tie was performed to determine the radius required and resultant stresses. The general gate model consisted of 8,931 three-dimensional single-order quadrilateral shell elements and 1,506 three-dimensional beam elements. Because of large, out-of-plane friction forces that develop under hydrostatic load, stress analysis of the end post (plate) was performed using three-dimensional solid elements. The final design included tension ties consisting of 50- by 686-mm (2-in. by 2-ft 3-in.) plate lying flat, with vertical bracing at 3353-mm (11-ft) intervals. Vertical bracing and hydrostatic loads were resisted with a plate girder located at the top spanning the width of the gate. The skin plate was 32 mm (1 1/4 in.) thick with intercostals spanning the arch plates in the upper third of the gate. The arch consisted of 38- by 610-mm (1-1/2 in. by 2-ft) plate. Loads were transferred to end bearing plates in the concrete through an 89-mm-(3-1/2-in.-) thick end post (plate). Side rollers were replaced with a compressible shoe to eliminate crushing of the steel

rollers that had occurred on the existing gate. Other structural replacements included new wire ropes, new 305-mm-(12-in.-) diameter stainless steel lift pins, and additional concrete ballast and support plates for the counterweight.

b. *Material.* ASTM A572/A572M, Type 2, Grade 345 (50) steel (ASTM 1994a) was selected based on material toughness, strength, availability, and weldability. The higher strength steel helped reduce the overall weight of the gate, which was a consideration for using the existing hoisting equipment. This provided a significant cost savings in the overall design of the gate.

c. *Gate operation.* The existing drum, bull wheel, and hydraulic drive system remained in place. The existing selsyn drive was modified to include a zero backlash speed reducer and couplings, along with new limit switches.

d. *Fabrication.* Because the gate was 27 432 mm (90 ft) high by 26 670 mm (87 ft 6 in.) wide, the gate was fabricated in three sections. Individual sections of the gate were welded in the fabricator's yard, barged to the site, and erected in the gate slot. Because most of the welds in the tension tie and arch were considered fracture critical, welding procedures, including welder qualifications, joint preparation,

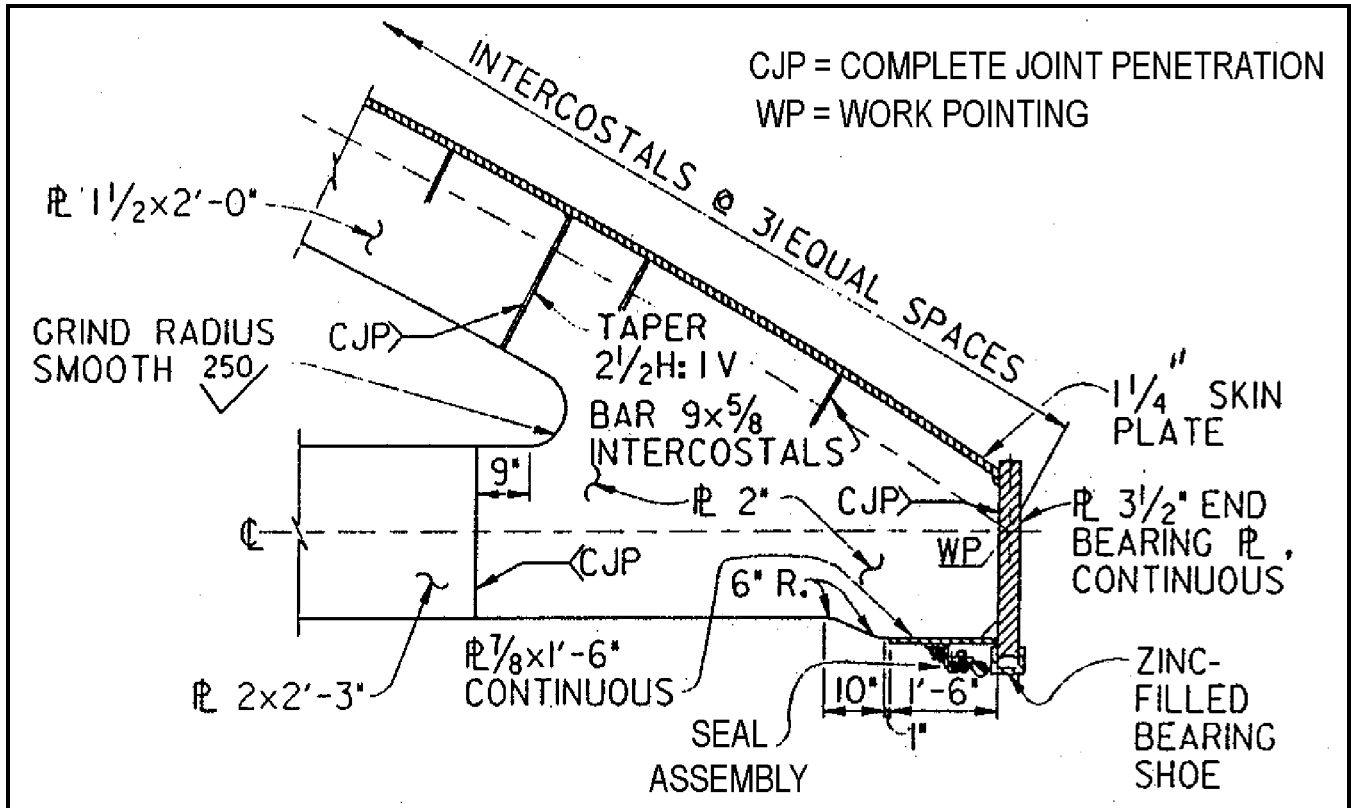

Figure B-3. Connection of compression arch to the tension tie and end bearing plate for the replacement gate

electrode type, and pre- and post-heating temperatures followed AWS D1.5-96 (AWS 1996a). The design was modified during construction to require a full penetration weld joining the gate section skin plate and end post. Scheduled lock outage for the erection of the gate was from 1 January to 29 February 1996, which was extended to 9 March 1996.

e. Corrosion. Corrosion protection for the gate uses a paint system for its primary defense, with cathodic protection applied at the top of the gate where painted mild steel plates connect to a stainless steel pin and cables. Other areas for corrosion potential are where stainless steel bolts were used for connecting seal angles to the gate and seals to the seal angles. All mild steel surfaces are painted. The seal angle mounting detail was revised to provide a neoprene gasket between the stainless steel seal angle and the gate. This will help prevent leakage as well as provide a separation from the two dissimilar metals.

Section II

Locks No. 7, Upstream Gate, Downstream Gate Leaf Replacement

B-6. Background

Locks No. 27 are located on the Chain of Rocks Canal (which bypasses the Chain of Rocks stretch of the Mississippi River) at Granite City, Illinois. Construction of the locks was completed in 1953. The locks consist of a main lock, 365 760 by 33 528 mm (1,200 by 110 ft), and an auxiliary lock, 182 880 by 33 528 mm (600 by 110 ft). The lock gates consist of vertical lift gates at the upstream end and miter gates at the downstream end of the locks. Prior to the addition of a low-water dam at the Chain of Rocks on the Mississippi River in the early 1960's and a subsequent raise in pool elevation at Locks 27, alterations were made to the lift gates to accommodate the higher head caused by the addition of the low-water dam.

B-7. Original Design and Construction

Each lift gate consists of two welded structural steel leaves that span the width of the lock chamber. Each gate leaf is 9144 mm (30 ft) high. A skin plate on the upstream side of each gate leaf forms the vertical damming surface. Plate girders transfer horizontal loads acting on the skin plate to the reactions at the lock walls. The top girder of the upstream gate leaf forms a horizontal damming surface, with pressure from the upper pool acting on the top surface and pressure from the lower pool acting on the bottom of the girder. The bracing on the downstream side of the gate leaf between the girders forms a truss to support vertical loads. Sealed buoyancy chambers are intended to be watertight and provide a reduction in vertical load. Chains and associated machinery, located in

recesses in the lock walls at each end of the gate, adjust the elevation of the gate leaves. The upper gate leaf (downstream gate leaf) is operated (lowered and raised) for each lockage. The lower gate leaf (upstream gate leaf) is operated infrequently, only to adjust for varying pool elevations. Plate 4, main text, shows gate geometry. For large hydrostatic heads, which occur at minimum upper pool levels, the upstream gate leaf is required to be supported on the gate rests at the bottom of the lock.

B-8. Structural Failures

Severe cracking in the upstream gate leaf was discovered in March 1989 during an unrelated construction contract at the main lock. Under normal conditions, the upstream gate leaf is submerged and is not visible. An inspection of the gate leaf revealed numerous cracks in the girders and bracing, adjacent to connections, on the downstream face of the upstream gate leaf. Additionally, all buoyancy chambers were found to be flooded. It is believed the cracking was a result of fatigue as the gate leaf had undergone approximately 250,000 loading cycles at that time. Additionally, almost all of the numerous downstream bracing connections were fatigue category E or E' according to AISC Appendix K (AISC 1995). As part of the alterations in 1960, additional vertical members were added to the downstream bracing, and cover plates were added to the tension flanges of the girders. The connections for these members resulted in additional category E' fatigue details.

B-9. Corrective Actions

Because the damage was considered to be severe, an emergency contract was written for initial repairs to the gate leaf so that the lock could open as planned for the unrelated construction contract. After completion of the initial repairs, a plan of action for permanent repairs was established. The plan involved material testing, review of the original structural computations, placement of strain gauges on the gate leaf, and an in-depth structural analysis using a three-dimensional computer model. Frequent inspections of the gate leaf were conducted while permanent repairs were being considered.

a. Initial repairs. The intention of the initial repairs was to return the gate leaf as much as possible to its original condition while permanent repairs were being considered. Cracks in girder flanges were gouged and fastened using full penetration welds. Cracks in girder webs were gouged and welded closed. The crack tips were located using dye penetrant and a 25.4-mm-(1-in.-) diameter hole was drilled at the crack tip; the holes were left open. Gusset plates were used where the downstream bracing members tied into the horizontal girder flanges to stiffen the joints and to facilitate the repair. Weld repairs were nondestructively examined.

b. Material testing. Samples of material from the original construction contract and alteration contract were removed and tested. Plate, angle, bar, and weld material were tested. The following tests were performed:

(1) Charpy V-Notch. This test provides an indication of a material's ability to absorb energy, which is directly related to toughness (a material's ability to resist crack propagation). The data from the testing for all samples indicated that this material had poor toughness compared to historical data for similar material.

(2) Tensile. Tensile tests were performed to determine yield strength, ultimate strength, and percent elongation. The yield strengths varied from 200 to 241 MPa (29 to 35 ksi) (the material was ASTM A7.) Elongation values were appropriate.

(3) Chemical analyses. Chemical analyses determined the percentage of 10 different elements. These analyses provided information that was used to evaluate two aspects concerning the weldability of the material: the susceptibility to underbead cracking and the potential for heat-affected zone cracking. The carbon content was found to exceed the limit for ASTM A7. As carbon content increases, a material will tend to behave in a more brittle manner.

(4) Micro hardness survey and Brinell hardness. Brinell hardness tests (ASTM 1996e), along with micro hardness surveys and chemical composition tests, provided information to evaluate the susceptibility to cracking. The test data showed that all samples had hardness values below the maximum suggested limiting values to assure satisfactory performance against underbead cracking and heat-affected zone cracking, thus indicating the material was satisfactory in this respect.

(5) Fracture analysis. A fracture analysis of a crack located in the angle was performed to determine additional information concerning how the crack developed. The fracture analysis revealed that the fracture was of a fatigue nature due to one-way bending and low to moderate overload in an area of concentrated high stresses.

c. Original structural computations. The original and alteration design computations were obtained and reviewed to determine what assumptions were made so they could be compared to the actual operating conditions. The gate leaf was analyzed using hand methods. Vertical water loads and dead loads (which included ice and mud loads) were assumed to be divided equally between the skin plate on the upstream face and the bracing on the downstream face. Horizontal loading was assumed to be transferred from the skin plate to the horizontal girders. It was further assumed that the three vertical diaphragms prevented differential loading between girders and caused the gate to deflect uniformly in the

horizontal direction. It was also assumed that the downstream bracing prevented local buckling of the downstream girder flanges as well as supporting the vertical load. The downstream bracing was assumed to act as five separate trusses, stacked on top of one another. Each truss was assumed to carry a portion of the total vertical load, the portion being the ratio of the panel height to the total gate leaf height. Buoyancy chambers located in the bottom two truss panels were designed to provide a buoyant force of 50 percent of the total gate weight.

d. Structural analysis. An in-depth structural analysis of the gate leaf using a three-dimensional computer model of the upstream gate leaf was conducted. The purpose of the analysis was to determine member stresses. A three-dimensional finite element model was used to analyze the gate leaf. Bending and stretching (6 degrees of freedom) elements were used to represent the skin plate, girder webs, buoyancy chambers, end framing, and reaction girder web. Beam elements were used to represent the girder flanges, skin plate intercostals, downstream bracing, chain girder, reaction girder flanges, and apron braces. The model consisted of approximately 600 nodes and 1,300 elements.

(1) Instrumentation. Because of the complex nature of the structural analysis of the lift gate, it was felt that some indication of service stress would be helpful in determining the validity of some assumptions concerning the analysis. Strain gages were placed on several downstream bracing members. For the original loading cases, the strain gages indicated member forces much higher than those indicated by the structural analysis. These data indicated a problem with the loading and/or the structural model. These were later investigated and corrected in the computer analysis, and better agreement was obtained.

(2) Conclusions from structural analysis. The controlling load condition was found to be a combination of the case added to account for the removal of the seal at the sill (removed in the 1960's in an attempt to abate vibration of the gate leaf) and the case added to account for the ineffectiveness of the buoyancy chambers. For the case of no seal at the sill, the net pressure varied from full net horizontal pressure at the top of the sill to zero net pressure at the bottom of the gate leaf (Figure 3-5, main text.) The results of the analysis using the loading cases described above showed improved agreement between overstressed members and members with observed failures, and also improved agreement with strain gage information. The results of the analysis indicated that the gate leaf underwent bending in both vertical and horizontal directions, not just horizontal bending as was assumed in the original computations. Bending in the vertical direction caused an increase in compression in the downstream bracing for certain loading conditions.

(a) Improper assumption of load distribution. It was apparent that horizontal loading of the lift gate had a greater effect on member forces in the downstream bracing than was believed by the original designers. The original designers believed all horizontal loads were distributed to the girders through the vertical diaphragms and the downstream bracing prevented only local buckling of the girder flanges under horizontal loading. However, it was clear from the computer analysis, and substantiated by the strain gage testing, that the lift gate acted as a unit under load with the downstream bracing affected by the distribution of the horizontal load. The additional compression in the downstream bracing face, caused by vertical loads due to water and weight of the gate, combined with horizontal loads resulted in overstress in the downstream bracing members.

(b) Omission of important load case. The original designers did not consider a load case for the buoyancy chambers zero percent effective while the gate was supported on the chains. During the gate repairs many of the chambers were found to be filled with water. The additional vertical load of the water in the buoyancy chambers caused further overstress in the downstream bracing members.

(c) Operating procedures. For higher heads the gate leaf should be supported on the gate rests at the bottom of the lock. Lock personnel identified that the gate leaf had been routinely supported on the chains for conditions when hydrostatic head exceeded the limiting value. This was due to conflicting information given in the operating manual and tolerances in the gate position indicating equipment. This contributed greatly to high stresses in the downstream bracing as indicated by the computer analysis of this loading condition.

(d) Modeling technique. The original designer's assumption of truss behavior of the downstream bracing members is unconservative. Furthermore, the gate was fabricated with many eccentric joints. Both of these items introduced bending moments into the downstream bracing members, which increased the stress. The simplified assumption that the downstream bracing behaved as a truss was made necessary by the crude analysis tools available at that time.

e. Final conclusions. Based on the results from the material testing program, structural analysis, and other information obtained, at least five factors, discussed below, contributed to the cracking of the gate. Based on the cost of repairs and the fact that much of the gate leaf would still have deficient material and welds, the final district recommendation was to replace the upstream gate leaf of the main lock lift gate.

(1) Defective material. The material used to fabricate the gate and the material used for the alterations made to the gate in 1960 both had very poor toughness relative to similar

material being produced presently. These materials did not have the ability to resist crack propagation once a crack initiated from overstress or fatigue.

(2) Design assumptions. Some of the original design assumptions concerning load distribution, load cases, and modeling technique were unconservative. This resulted in actual member stresses (as indicated by the computer analysis and instrumentation) higher than those predicted in the original design. In addition, the bracing connection details were fatigue category E and E' according to AISC (1995) Appendix K, and no consideration was given to fatigue in the design.

(3) Operating procedures. The operating procedures were such that under certain conditions the gate was not on the supports for some loading conditions, as assumed in the design. This resulted in additional load in the bracing. The limit switches for the gate leaf have since been reset to account for tolerances in the gate position indicating equipment to prevent the condition from occurring again.

(4) Fabrication procedure. There was no evidence of low hydrogen welding practice. This is poor practice considering the alterations to the gate leaves in 1960 were made during the winter months. These practices made the welds susceptible to cracking. Also many of the welds were undercut, which reduced the cross-sectional area of the bracing and caused stress risers and susceptibility to cracking. Approximately 90 percent of the welds connecting the downstream bracing to the girder flanges were found to be deficient (did not meet AWS (1996a) bridge specifications) by an independent testing laboratory that performed an inspection as part of the repair contract. In addition to undercutting, the welds did not meet AWS (1996a) profile and porosity requirements. The deficient welds were repaired during the initial repair contract.

(5) Corrosion. As cracks initiate and begin to propagate, corrosion occurs at the crack tip and reduces the critical stress intensity factor, thus promoting crack growth. Corrosion also causes reduction in the net area of members, resulting in increased stresses.

B-10. Design and Construction of New Gate Leaf

The five factors identified in the investigation of the existing gate leaf as contributing to the cracking of the gate leaf, as well as altering the structural configuration, were considered in the design of the new gate leaf.

a. Material toughness. For adequate material toughness a minimum toughness requirement for all members was written into the specification. To minimize gate weight, ASTM A572/A572M Grade 345 (50) steel (ASTM 1994a) was used. Deflections were considered and kept within acceptable limits.

b. Design assumptions. A three-dimensional finite element model was used for the design of the new gate leaf. Much information concerning overall gate leaf behavior and distribution of loads was obtained, minimizing the number of assumptions necessary. Because of concerns regarding the reliability of buoyancy chambers, they were not used in the new gate leaf. Loading cases generally followed the original gate leaf except for an additional case to account for the missing water seal at the sill.

c. Structural configuration. Similar to the existing gate leaf, the new gate leaf is horizontally framed. The horizontal girder spacing was altered to provide uniformity, which is the most efficient when considering all possible loading conditions. Based on the results of the structural model and gate testing, it was determined that additional vertical diaphragms were necessary. A vertical diaphragm was placed at each panel point. Panel point spacing remains the same as the original gate leaf and corresponds to the spacing of the gate rests at the bottom of the lock. For the downstream bracing, a perforated skin plate was used instead of discrete bracing members. The rounded perforations provide access for inspection as well as a reduction in gate weight. The system of discrete downstream bracing members was flawed in that it was difficult to obtain connections that were not susceptible to fatigue. The skin plate with smooth rounded perforations has very good resistance to fracture and fatigue. All connections throughout the new gate leaf were designed in accordance with AISC (1995), Appendix K. Improving fatigue performance involved stopping transverse stiffeners short of tension girder

flanges, and coping vertical diaphragms so that no contact is made with girder flanges. All joint details were designed so that allowable stress ranges would not be exceeded.

d. Operating procedures. The original gate leaf used float-operated selsyn transmitters to report the position of the gate leaf. This type of device is unreliable for determining if the gate leaf is supported on the rests or on the chains. Hence, operating restrictions with regard to when the gate leaf was required to be on the rests or on the chains could not be met. A system of digital encoders was installed, replacing the original selsyn transmitting equipment. The new system, mounted on the existing chain sprocket, accurately indicates when the gate leaf is supported on the rests or on the chains and therefore ensures that operating restrictions can be met.

e. Fabrication. The majority of the new gate leaf was fabricated in the shop, where conditions are readily controlled. Strict control of welding procedures, including welder qualification, joint preparation, electrode preparation, and pre- and post-heating temperatures, was maintained. Low hydrogen welding practice, in accordance with AWS D1.1 (AWS 1996b), was specified for all welded connections.

f. Corrosion. Elimination of crack potential was a major goal in the design of the new gate leaf; however, should cracking occur during the service life of the new gate leaf, corrosion will be minimized through the use of passive cathodic protection devices mounted at regular intervals.

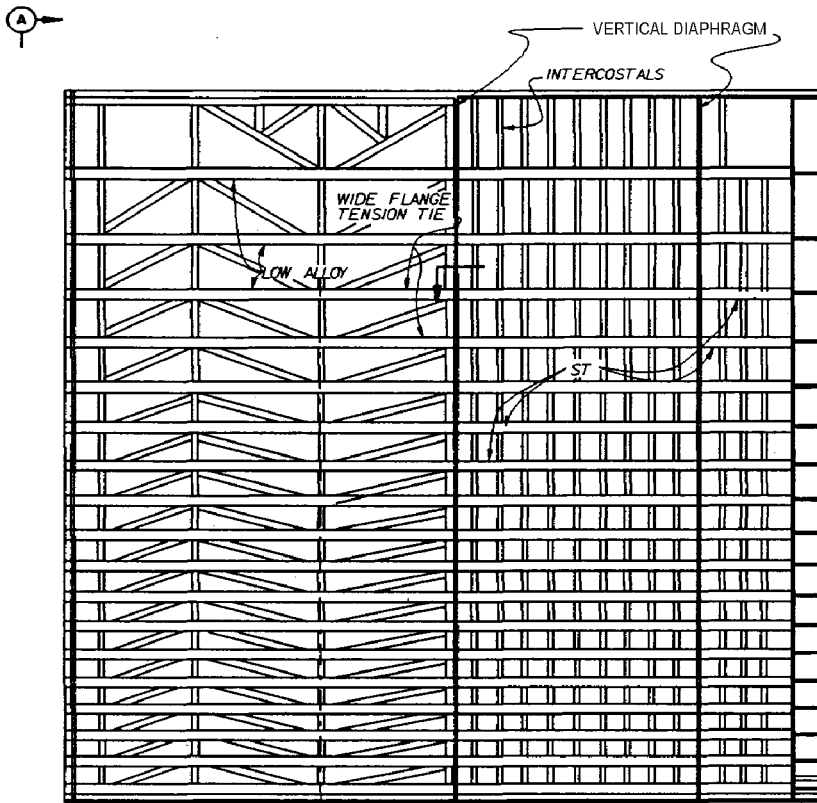

REAR CHORD FRAMING SKIN PLATE FRAMING
ELEVATION LOOKING UPSTREAM

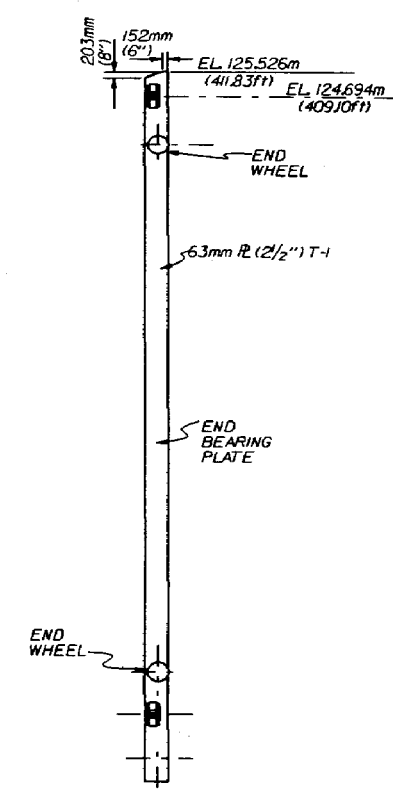

SECTION A

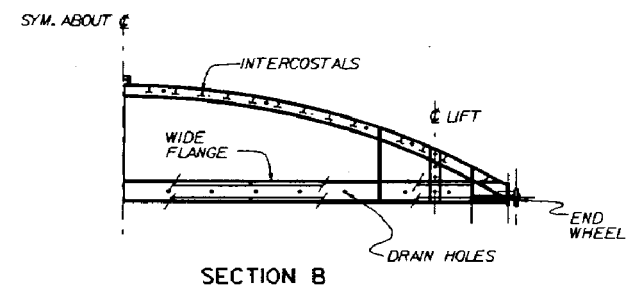

SECTION B

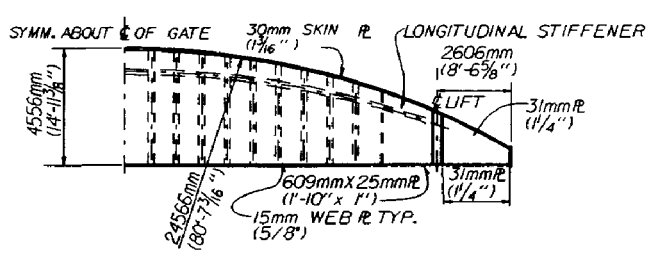

HALF PLAN OF TOP GIRDER

NOTE: NOT TO SCALE

Snake River, Ore., Ida., Wash
ICE HARBOR LOCK AND DAM
NAVIGATION LOCK
OLD
DOWNSTREAM LIFT GATE

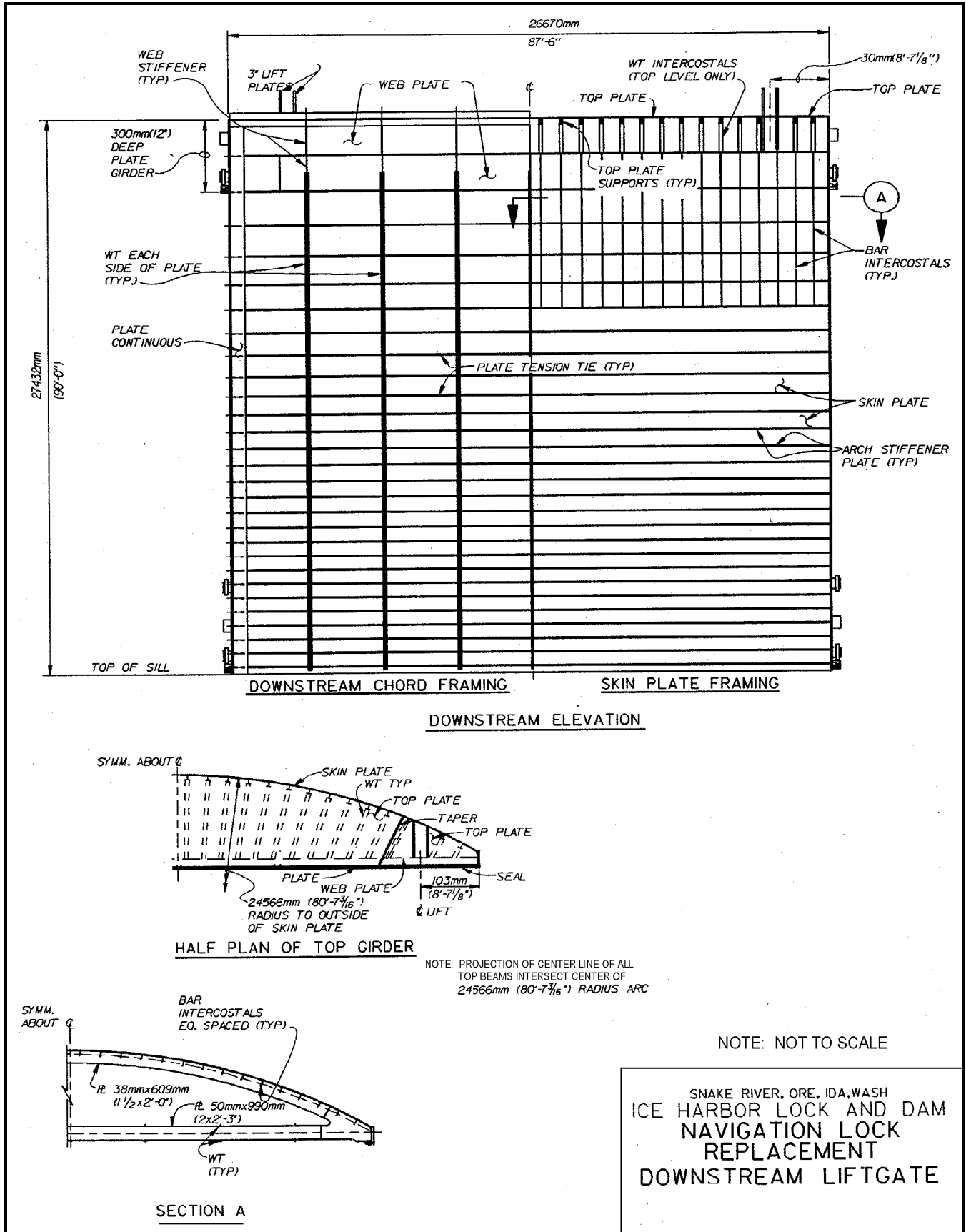

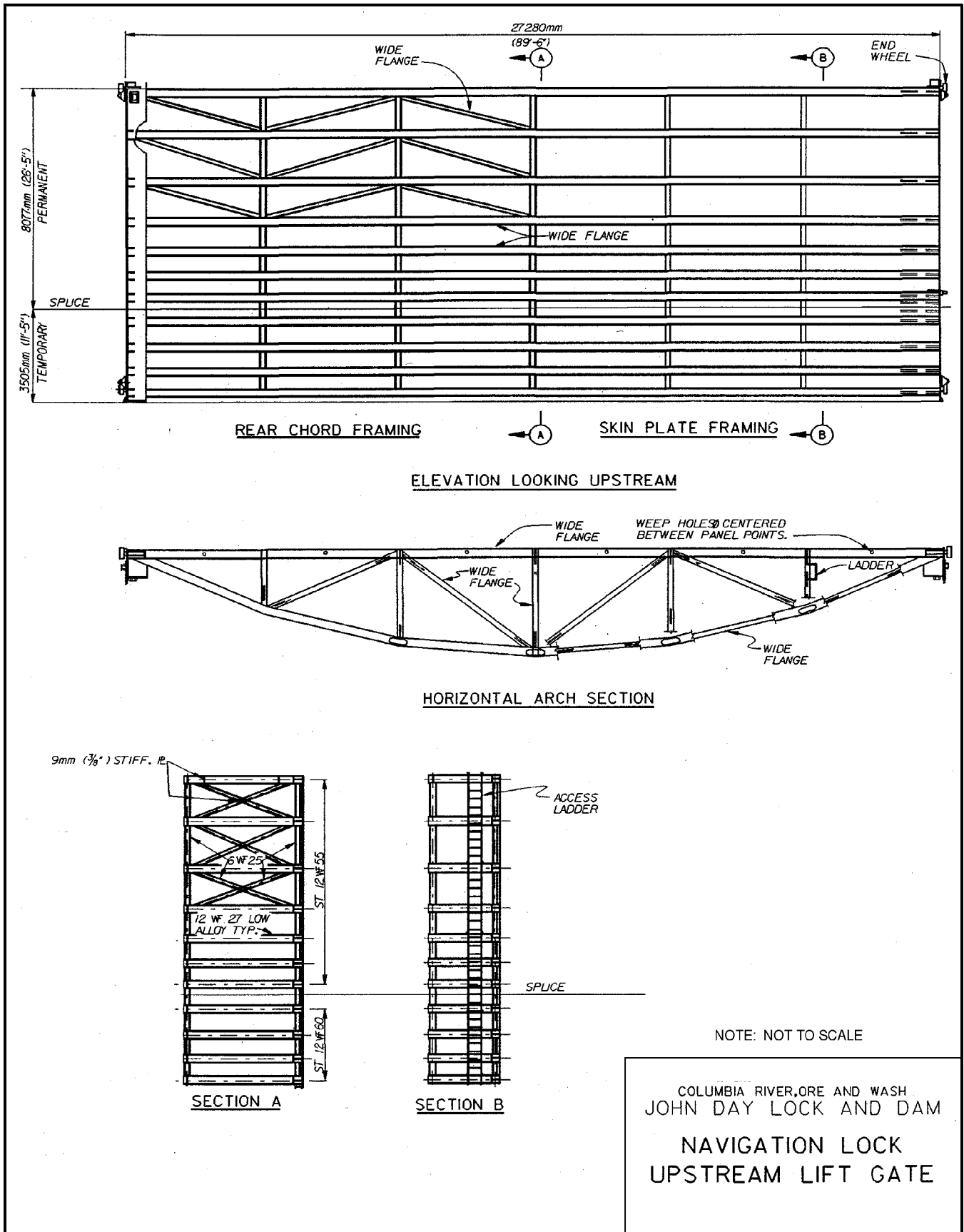

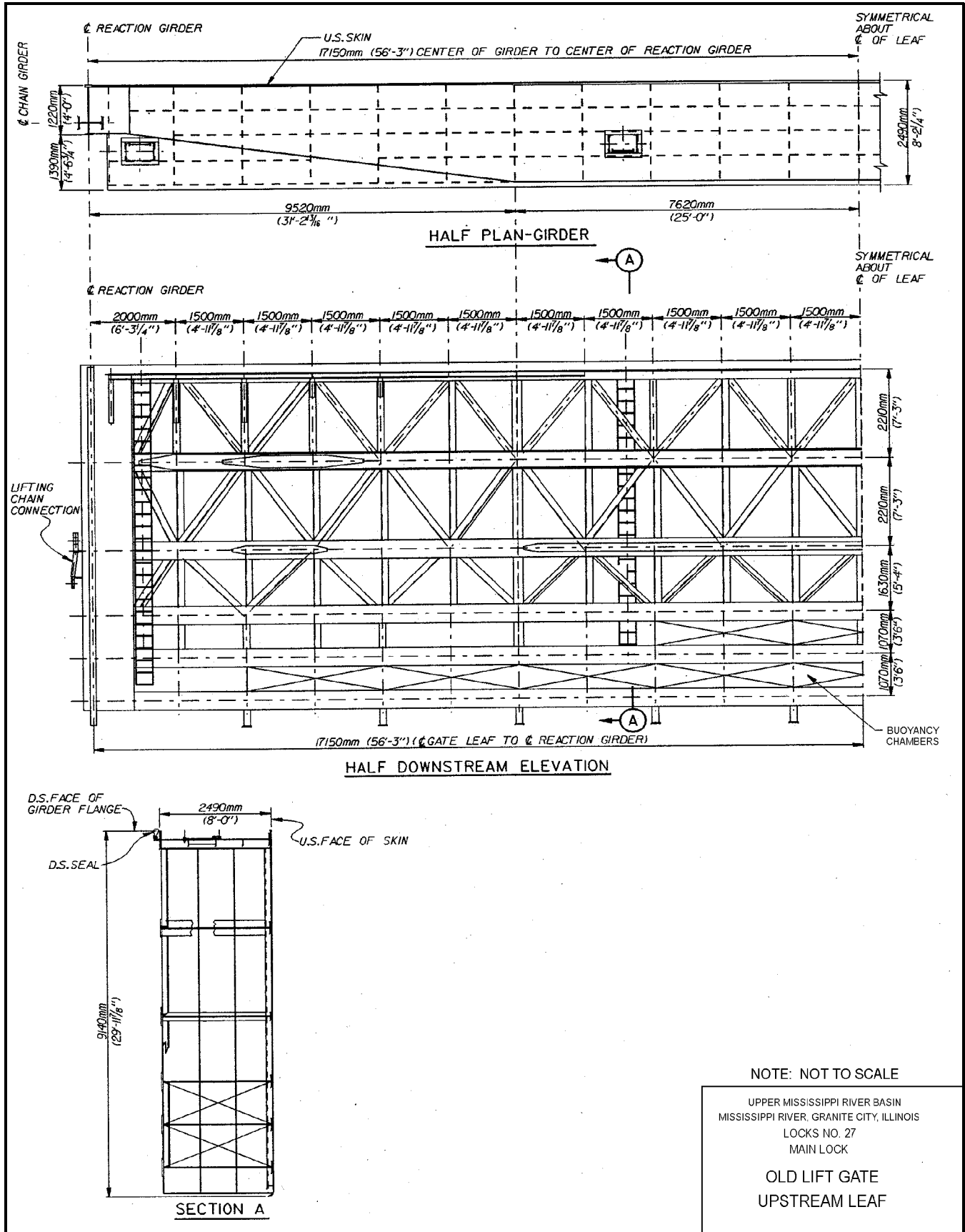

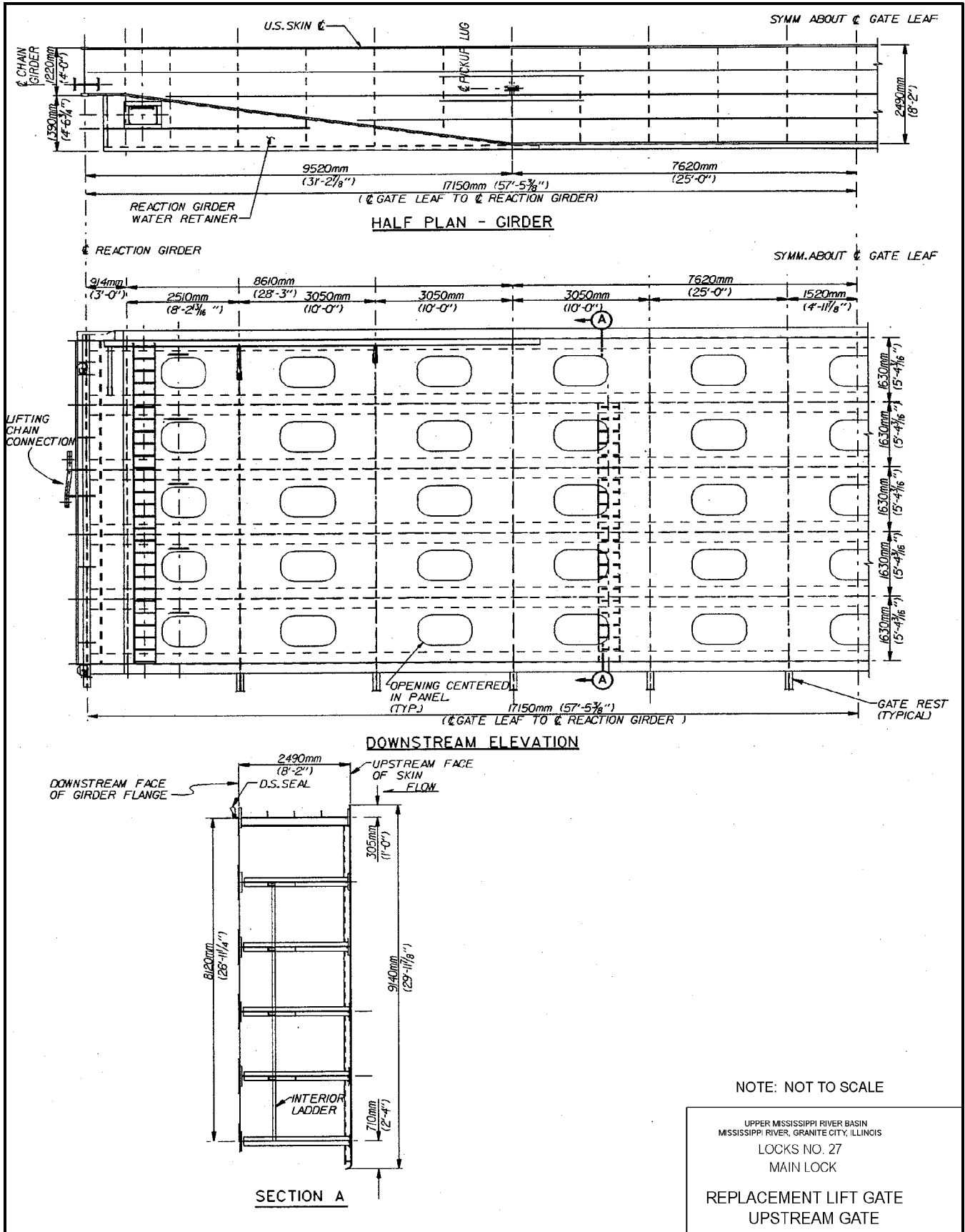

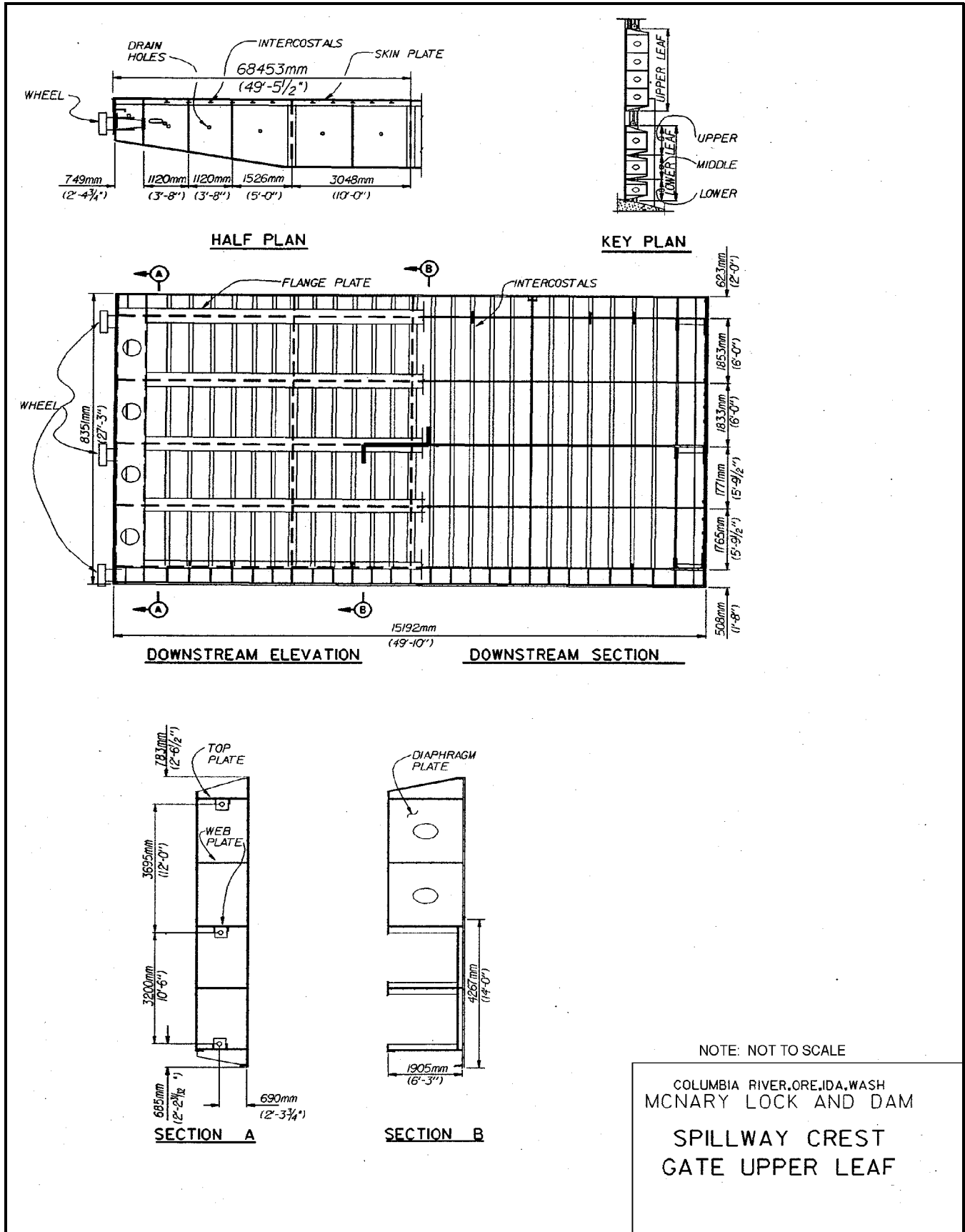

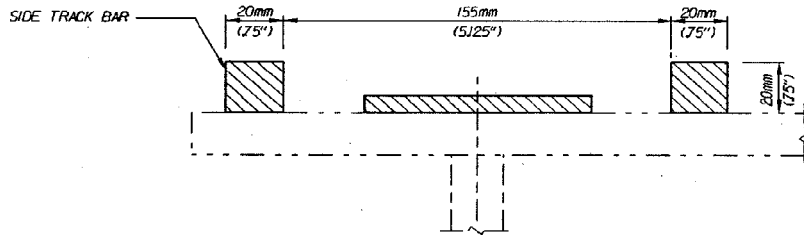

UPSTREAM ROLLER TRACK

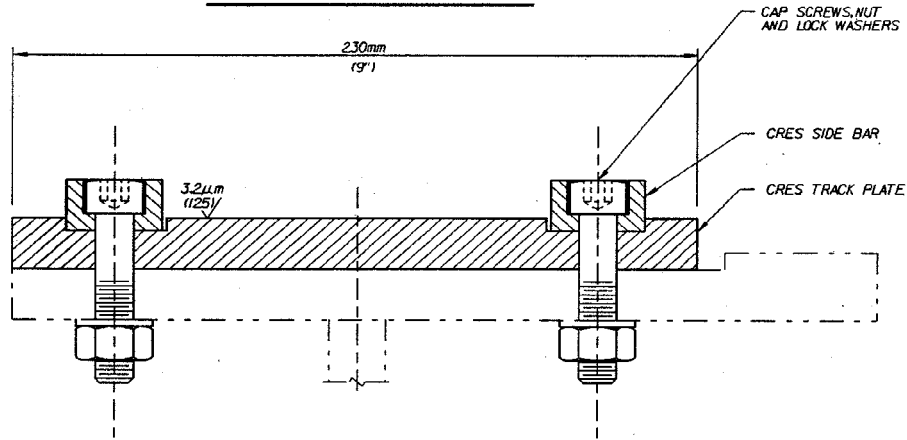

DOWNSTREAM ROLLER TRACK

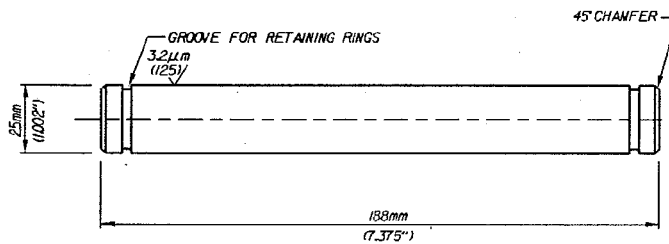

ROLLER PIN

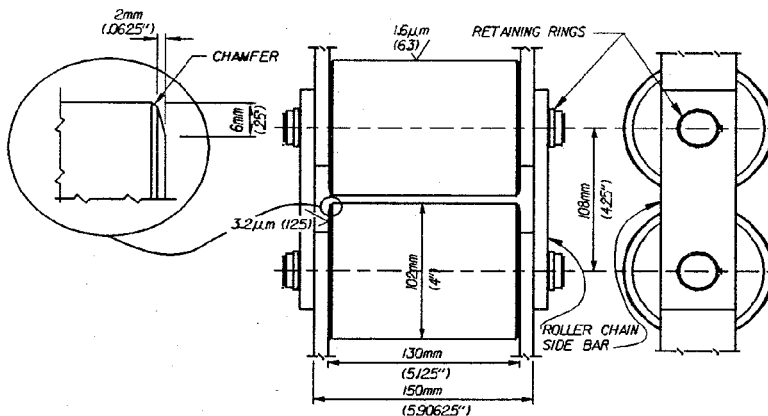

TYPICAL ROLLER ASSEMBLY

CRES = CORROSION RESISTANT STEEL

NOTE: NOT TO SCALE

**TRACTOR GATE
CHAIN AND ROLLER
TRACK DETAILS**

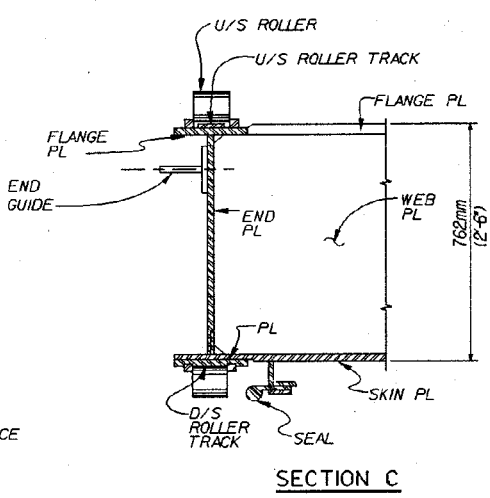
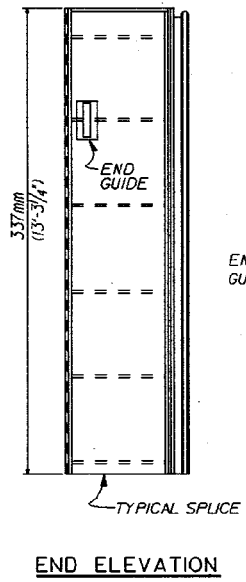
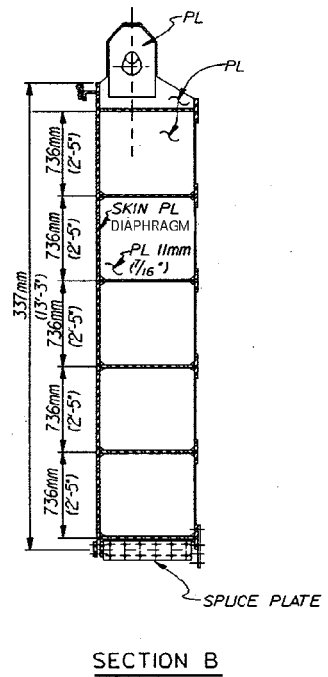
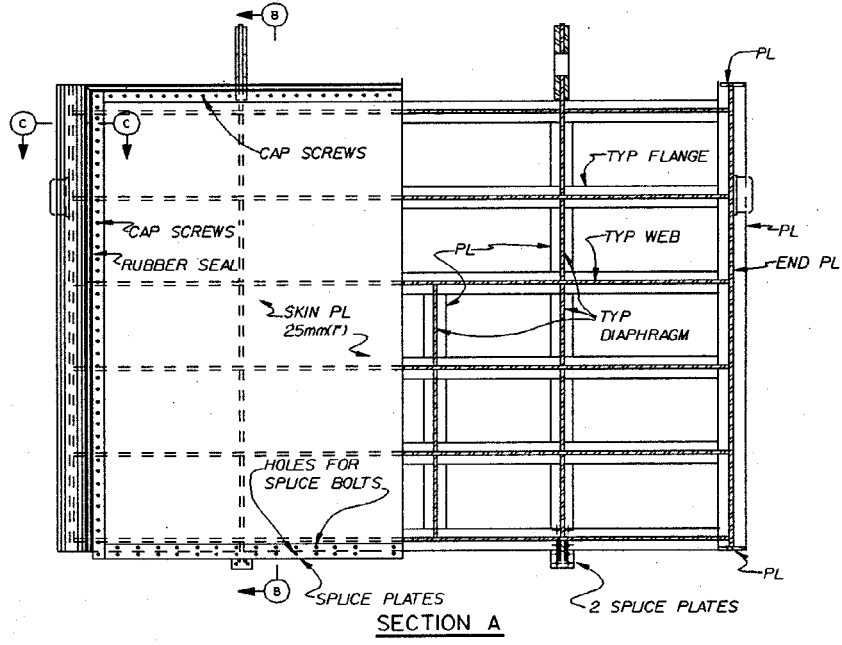
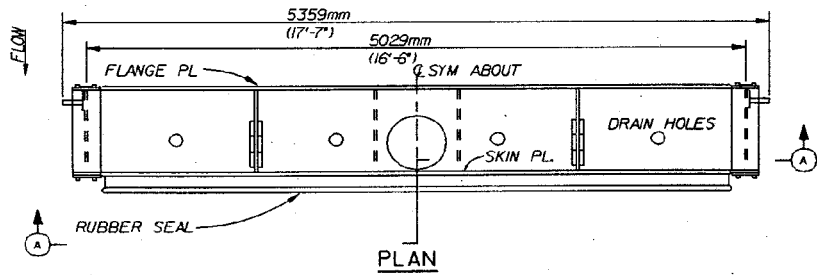

NOTE: NOT TO SCALE

COLUMBIA RIVER, ORE AND WASH
BONNEVILLE LOCK AND DAM
FISH TURBINE EMERGENCY
CLOSURE GATE

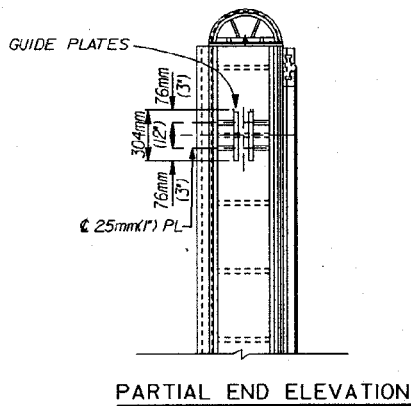
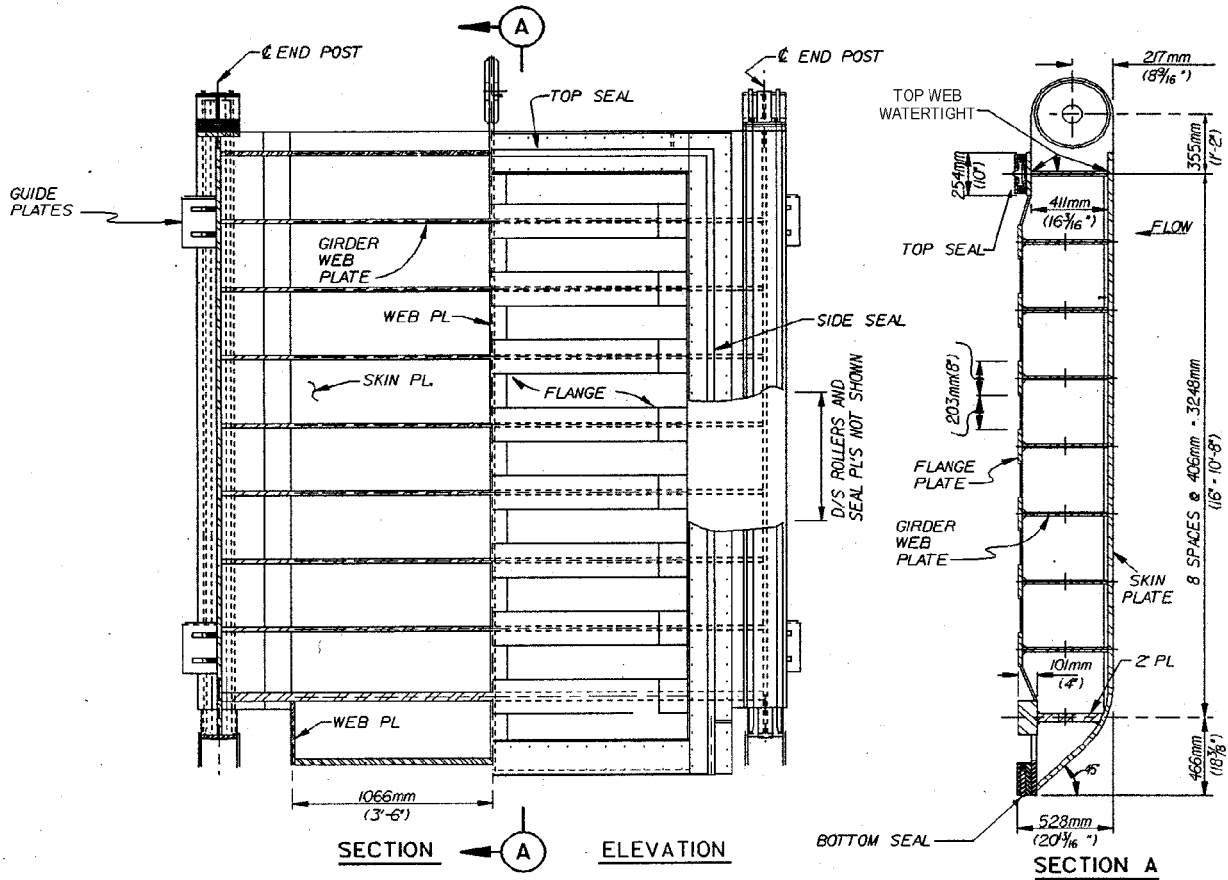
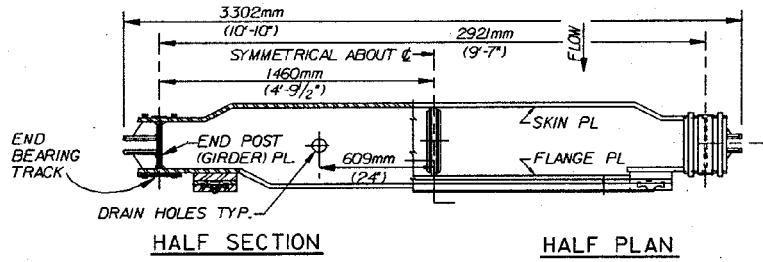

NOTE: NOT TO SCALE

WHITE RIVER, WASHINGTON
MUD MOUNTAIN DAM
EMERGENCY CLOSURE
GATES

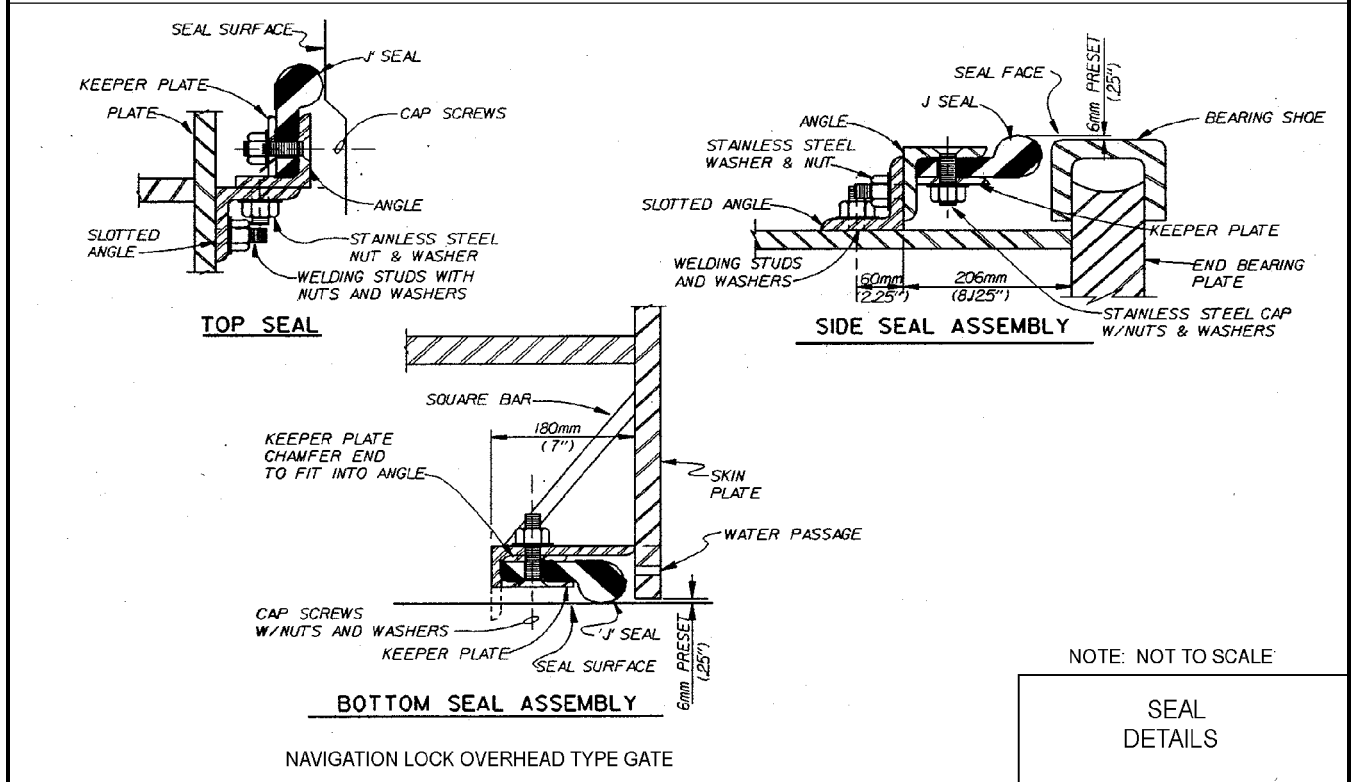
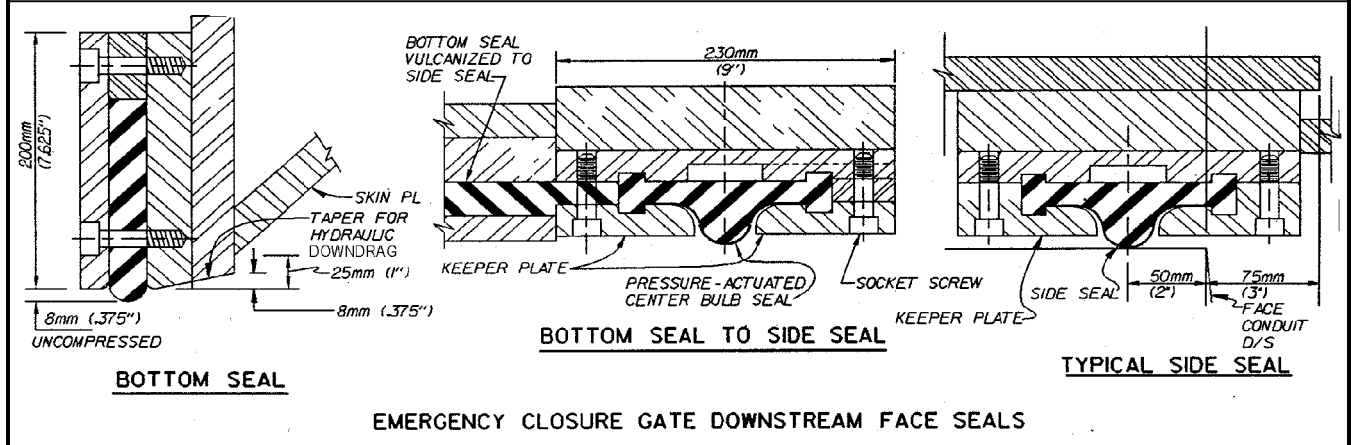
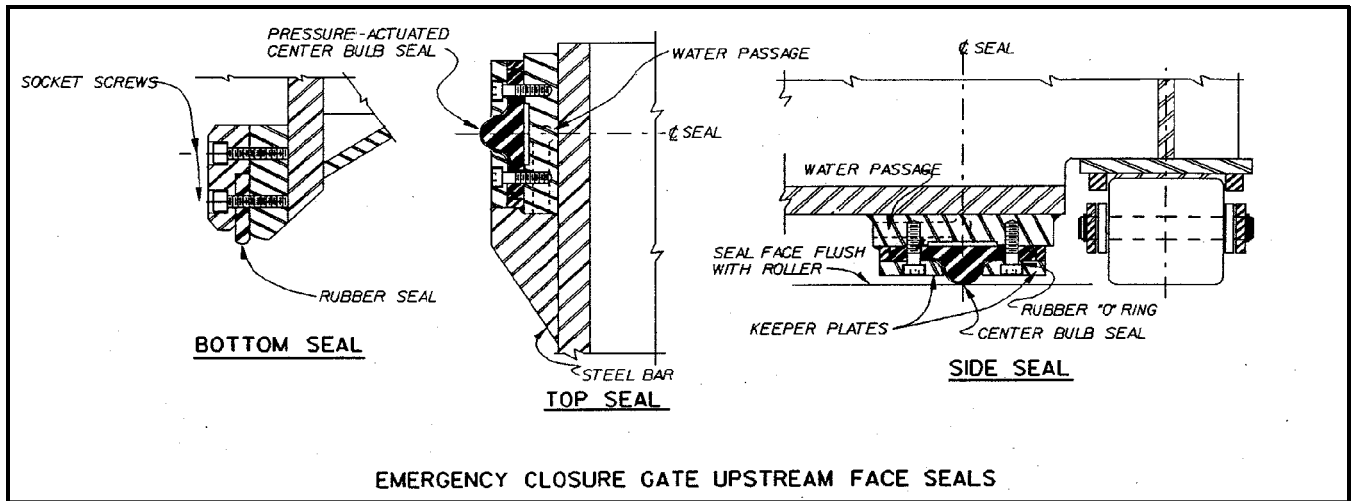

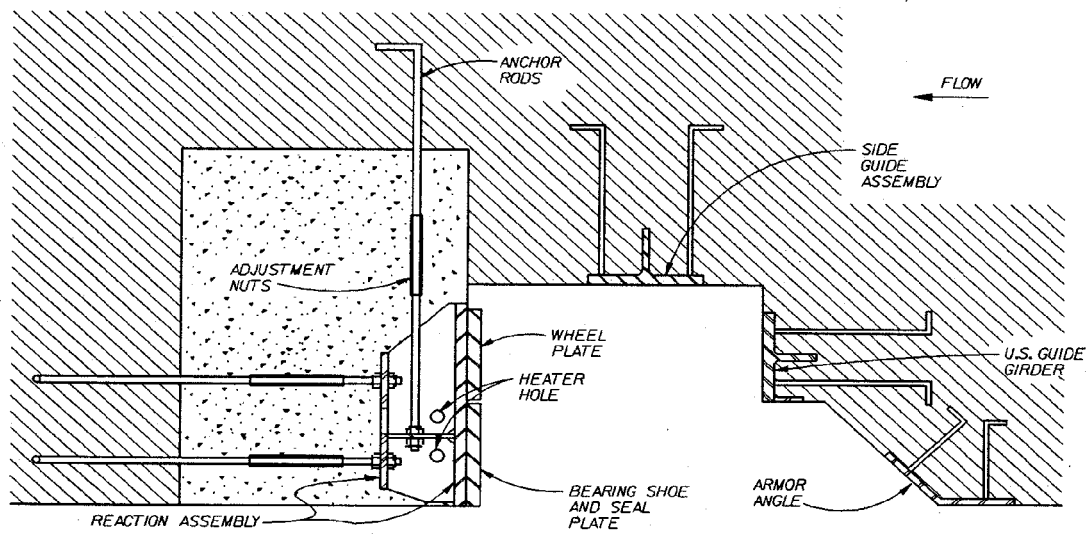
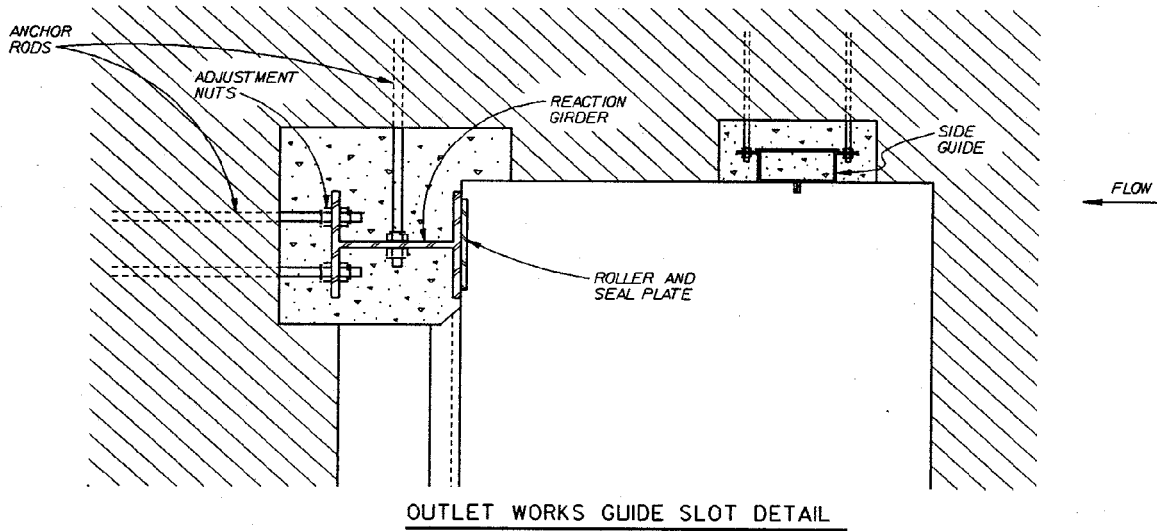
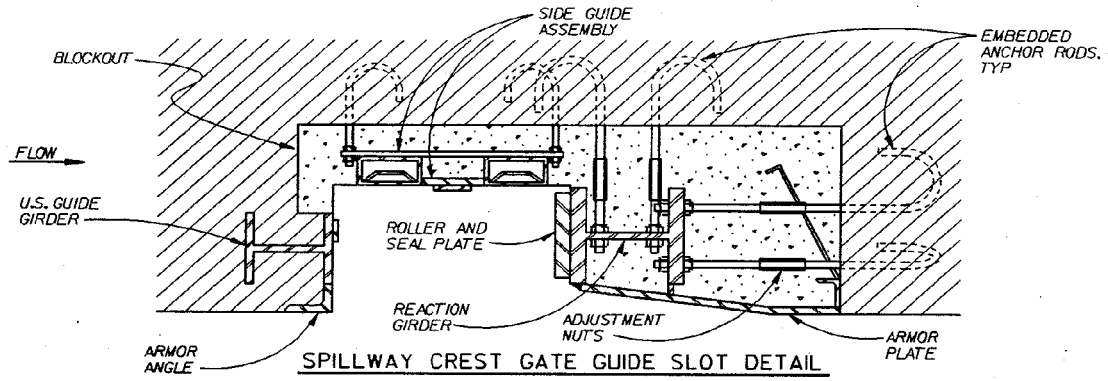

NOTE: NOT TO SCALE

GUIDE DETAILS

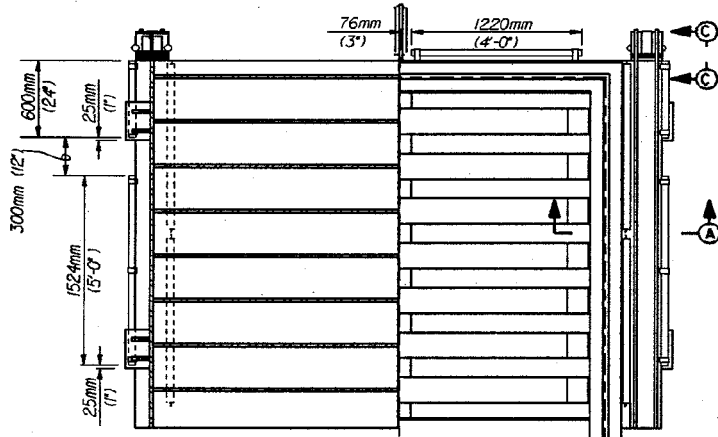
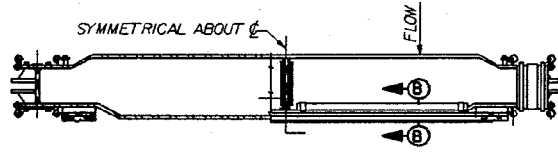

ELEVATION EMERGENCY GATE

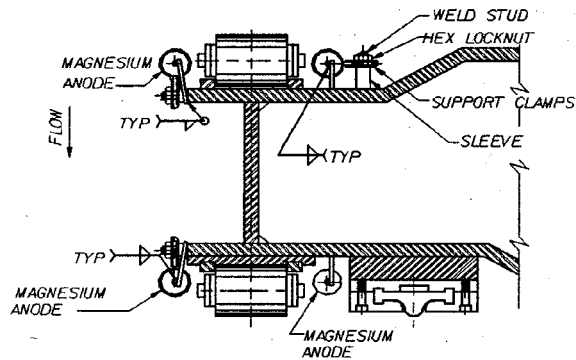

SECTION A

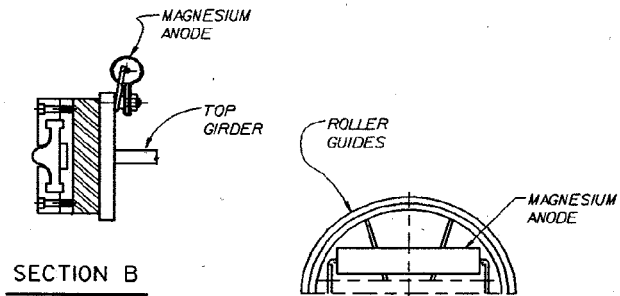

NOTE: NOT TO SCALE

CATHODIC PROTECTION
 DETAILS