

COMPLETION REPORT
UPPER STOKES
FISH PASSAGE IMPROVEMENT PROJECT
BEAVER CREEK,
METHOW SUBBASIN, WASHINGTON
MARCH 2004



On the cover

Cover Photo 1. Upper Stokes Fish Passage Improvement Project — nearly completed double-drop (A-shaped) Weir No. 1; backfill not yet done.

Cover Photo 2. Upper Stokes Fish Passage Improvement Project — Completed project with silt fence in place. View looking at lower position of A-shaped Weir No. 1. Headgate diversion structure is at left side of photo (photo taken November 2003).

CONTENTS

1. INTRODUCTION AND BACKGROUND	1
1.1 ENDANGERED SPECIES ACT (ESA)	1
1.2 PROBLEMS AND SOLUTIONS.....	2
1.3 PARTICIPATION AND COOPERATION	2
1.4 PERMITTING	3
1.5 CONTRACTS SPECIFICATIONS AND BIDDING	3
2. PROJECT DESCRIPTION	4
2.1 PROJECT MATERIALS, QUANTITIES, AND SUPPLIERS.....	4
2.2 CONSTRUCTION TIMELINE.....	6
3. CONCLUSIONS	7

APPENDIX A. CONSTRUCTION PHOTOGRAPHS

All photographs by U.S. Bureau of Reclamation, Pacific Northwest Region, Boise, Idaho, PN-3400/Design Group, Boise, Idaho, October 2003 (except as noted)

APPENDIX B. AS-BUILT DRAWINGS

Figure B-1. Location Map, Upper and Lower Stokes Diversions (1678-100-272)

Figure B-2. Upper Stokes Diversion, Diversion Structure, Plan, Detail, and Section (1678-100-277)

Figure B-3. Upper Diversion, Diversion Profile (1678-100-278)

Figure B-4. Upper Diversion, Cross Vane Weirs, Profiles and Sections (1678-100-279)

Figure B-5. Upper Diversion, Diversion Structure, Plan and Sections (1678-100-280)

Figure B-6. Upper Diversion, Diversion Structure, Plan Detail, and Section (1678-100-299)

1. INTRODUCTION AND BACKGROUND

In the fall of 2003, the Upper Stokes Diversion Dam (photo A-1), identified by the Washington Department of Fish and Wildlife (WDFW) as a barrier to fish movement, was replaced by two rock weirs. These allow fish passage for all species and life stages, meet diversion flow requirements for the landowner, and are less noticeable. The project, the second of three in the area, is located on Beaver Creek, a tributary of the Methow River in Okanogan County, Washington. This report explains the design process and regulatory requirements leading to the new diversion and documents the construction that took place. To better illustrate what was accomplished, we have included two appendices. Appendix A shows a series of photographs documenting the work that was done. Appendix B contains “as-built” drawings of the project.

1.1 ENDANGERED SPECIES ACT (ESA)

The ESA requires all Federal agencies, including the Bureau of Reclamation (Reclamation), to take actions that will assist in the protection of “listed” species. Under the ESA, NOAA Fisheries (formerly the National Marine Fisheries Service or NMFS) oversees the protection and recovery of certain “endangered” or “threatened” species, including salmon and steelhead. NOAA Fisheries’ judgment of how to protect these species is presented in a “biological opinion” (BiOp) issued to Federal agencies. A BiOp is a detailed description of the present situation and includes actions which Federal agencies are required to take.

The Federal Columbia River Power System (FCRPS) consists of 14 dams and related facilities operated by the U.S. Army Corps of Engineers (ACOE) and Reclamation; the Bonneville Power Administration (BPA) markets the power from these facilities. In December 2000, NMFS issued its “2000 FCRPS BiOp” containing 199 actions that BPA, ACOE, and Reclamation must implement. These actions are intended to avoid jeopardy to the continued survival of eight stocks of salmon and steelhead in the Columbia River Basin.

The responsibilities for habitat improvement are shared among the FCRPS agencies. Reclamation is currently working on fish passage improvements in nine tributary subbasins in Idaho, Oregon, and Washington, including the Methow River subbasin. There are no authorized Bureau of Reclamation projects in these subbasins. Actions identified in these subbasins are “off-site” from Reclamation’s projects and are designed to improve the survival of fish during spawning and rearing life stages. Reclamation’s charge for its nine subbasins is to work with willing partners on non-Federal lands to correct fish screen deficiencies, provide for fish passage at instream diversion barriers, and secure adequate instream flow for the listed fish.

1.2 PROBLEMS AND SOLUTIONS

The project is one of a series of voluntary efforts by various Beaver Creek landowners implemented by and through the Twin Creeks Coordinated Resources Management (CRM) process. The original surveys and the initial design work were provided by the USDA Natural Resources Conservation Service (NRCS). At the request of Beaver Creek landowners, Reclamation reviewed the existing NRCS work. Reclamation developed additional concepts. The irrigator selected his preference in coordination with the landowner. Reclamation then made final designs. The projects continued to evolve over time in response to landowner and permitting agency comments.

The Twin Creeks CRM meetings were an important tool, particularly during the early phases of the design process. (The meetings are held as necessary, usually about every six weeks.) Landowners in the Beaver Creek watershed, other interested parties, and all local, State, and Federal agencies with resource management responsibilities were invited to the Twin Creeks CRM meetings. The venue was used to explain and discuss the issues and processes involved in such projects. It was also a good forum to keep people informed of issues in the watershed and ongoing progress with project and grant applications. The meetings are an ongoing program and are coordinated by the Okanogan Conservation District (OCD).

Based on the early designs, OCD obtained construction funding for the project through a grant from the State of Washington Salmon Recovery Funding Board (SRFB, informally called the “Surf Board”). In addition, the district coordinated and administered the contracting process between the landowner and the construction company. OCD received and held the SRFB grant funds. When provided with paid invoices, the district reimbursed the landowner for contractor payments and for construction materials (such as pipe and the concrete diversion structure). The district also provided materials and manpower for restoration of the construction site. As part of the SRFB agreement, OCD will continue its participation by monitoring its restoration efforts

1.3 PARTICIPATION AND COOPERATION

The Upper Stokes Diversion fish passage improvement project was successful because of the teamwork of the willing participants. The Upper Stokes Diversion supplies water to the Stokes & Stokes Ranch. The irrigator provided a great deal of site and water flow information during the design phase of the project and was available to help with installation and to answer questions as they arose. In addition, he allowed the storage of materials at his ranch and helped load and unload materials as necessary. The Upper Stokes Diversion is located on land owned by the Campbell family, which provided access and staging areas.

Another important aspect of this project was the cooperation and coordination between the various permitting agencies; this was fostered in large part by their participation in the Twin Creeks CRM

process. As a result, the permitting agencies were involved with the design concepts from the beginning; this led to expedited permit issuance and no unpleasant surprises during construction. WDFW and the Okanogan National Forest provided valuable on-site assistance and advice during fish-salvage operations at no cost to the landowner.

Boulder Creek Contracting, locally owned by Pete and Patti DeLange, performed the construction work. The firm provided all heavy equipment and various other items, including a dewatering pump, motorized hand compactor, welding equipment, and hand tools.

1.4 PERMITTING

Because the State of Washington SRFB funding originated from Federal sources, consultation was required with NOAA Fisheries and with the U.S. Fish and Wildlife Service (FWS) under Section 7 of the ESA.

To save time and money, OCD prepared a single plan that combined six proposed projects on Beaver Creek and submitted one “biological assessment” (BA) to NOAA Fisheries and to FWS in March 2003. Reclamation provided technical assistance to OCD during consultation. NOAA Fisheries issued a single BiOp for all six projects on August 6, 2003, along with a letter of concurrence from FWS.

WDFW administers a coordinated interagency permitting process (Joint Aquatic Resource Permit Application, or “JARPA”). As part of this process, a “Hydraulic Project Approval” (HPA) is required from WDFW prior to construction. The HPA has specific requirements for the protection of aquatic habitat, streambank vegetation, prevention of oil and gas spills from equipment, and requirements for site restoration. A separate HPA is required for each project; the HPA for the Upper Stokes project was issued in early October, 2003.

1.5 CONTRACTS SPECIFICATIONS AND BIDDING

Technical specifications and contract language for the project were completed by Reclamation using standard NRCS format and language. The owner of the diversion dam, who was responsible for contract administration, reviewed and accepted the specifications and contract package. The diversion dam owner sent the specifications for the Upper Stokes project to nine contractors in June 2003. Proposals from the contractors were due on July 11, 2003; two were received.

For the Upper Stokes project, the contract for construction was between the landowner and the construction company. OCD received and held the SRFB grant funds. When provided with paid invoices, the district reimbursed the landowner for contractor payments and construction materials (such as pipe and the concrete diversion structure). During construction, Reclamation had no contractual relationship or other obligations with the contractor or OCD.

2. PROJECT DESCRIPTION

The purpose of the Upper Stokes project was to improve fish passage both upstream and down. This was accomplished by the removal of the old diversion dam and the construction of a new diversion using a rock weir. Rather than build several rock structures to raise the water surface to the existing headgate and ditch, the invert elevation of the new headgate, existing fishscreen, and ditch were lowered about 12 inches to reduce the water height required in the creek to make the diversion. The existing ditch runs quite a distance to the point of use and has a fairly steep slope, making it relatively easy to drop the ditch elevation.

The existing 3½-foot-high diversion dam, made of stacked logs and lined with plastic (photo A-1), was removed entirely. To replace it, a so-called “Rosgen” rock vortex (A-type) weir (Cover Photo No. 1) was installed at the former site of the existing log structure. The new weir was designed with two drops, each 0.8 foot, which meets State standards for fish passage. Because the large rocks establish a hardened point, Weir No. 1 provides “grade control;” this means the stream is unable to downcut its bed over time. It also forms a small pool at the new point of diversion which was sufficient to allow diversion of the water right.

As measured after construction, the downstream drop is actually over 1 foot, mostly as a result of channel restructuring downstream. However, some bedload is expected to drop out of the stream at high flows and accumulate just downstream of the scour hole; this would reduce the drop to the 0.8 foot design standard. If necessary, modifications to the structure or to the streambed downstream of the drop will be made after highwater in the spring of 2004.

Weir No. 2, a Rosgen V-type rock weir was constructed about 60 feet upstream from Weir No. 1. This was designed to provide grade control, stabilize the streambed, and eliminate “headcutting” (photo A-9). Headcutting is a large, downward movement of a streambed created when a stream is steepened.

A new diversion box and headgate was installed at Weir No. 1. About 40 feet of 18-inch-diameter conveyance pipe was installed from the diversion box to just upstream of the fishscreen. The old headgate was removed. Minor realignment of the ditch was also completed from the fishscreen to about 200 feet downstream.

2.1 PROJECT MATERIALS, QUANTITIES, AND SUPPLIERS

The materials used for the project were ordered separately from the construction contract. Invoices for materials were sent to the landowner who made payment to the suppliers; he was then reimbursed by OCD from the SRFB funds. The contractor was responsible only for the installation of materials.

The concrete diversion box — including the headgate, trashrack, grating, and pipe stub — was pre-cast locally and delivered to the site by Arm and Hammer Construction Company of Twisp. The

diversion box was built to the dimensions shown on the drawings with minor changes (the method of attaching the trashrack to the concrete box). The diversion box grating (on top) is standard 1-inch grate and galvanized as a unit (photo A-8). The trashrack was fabricated as a single piece and also galvanized. The pipe stub was 18-inch-diameter plastic irrigation pipe (PIP) rated for 100 psi.

The 18-inch conveyance pipe was also PIP but rated for 63 psi; one 20-foot section was installed from the diversion box into the ditch (photo A-10). After reviewing conditions in the field, the depth of the ditch after the pipe was determined too deep to be safe. Another 20-foot section of pipe was purchased, making the total length of pipe out of the diversion box 40 feet (photo A-10). The second length is 18-inch-diameter, double-wall, HDPE (high density polyethylene) pipe.

The connection between the two pipe sections was made by cutting lateral slits in the HDPE pipe and forcing it over the PIP pipe (photo A-12). The joint was then covered in concrete to a depth of three inches over the joint. Approximately eight bags of premixed concrete were used. The soils in which the pipe was placed were a sandy-silt with significant number of cobble-sized material. The average depth of fill over the pipe is about 5 feet. All pipe for this project was supplied by Cascade Pipe and Feed Supply of Twisp.

The worksite was dewatered using 30-inch-diameter, double-wall, HDPE pipe, which was routed around the construction area (photo A-6); the pipe and its watertight gaskets were manufactured by the ADS Company. A total of 200 feet of dewatering pipe and two 45-degree fittings were purchased for use on several projects. About 125 feet of dewatering pipe was used for the Upper Stokes project. No fittings were required. Surface excavation ranging in depth from 1 to 5 feet was needed to ensure proper grade. The dewatering pipeline was not backfilled unless necessary for weight on the pipe or where the equipment needed to cross. The dewatering pipe was used for other Beaver Creek projects and OCD divided the cost among them

The large-diameter rocks used in this project (photo A-5) were provided by a family-owned quarry located about 30 miles east, near the town of Malott. After inspection and selection, about 100 rocks of various sizes were brought to the site around October 10th. Additional rocks were delivered from another commercial pit but calcite lenses limited their use, and no further rocks were ordered from that pit. The Malott rocks were angular and granitic ranging from just less than 2 feet in average diameter to over 4 feet. The estimated weights of the rocks ranged from 600 to 4,000 pounds.

The material excavated from the two rock weir sites was similar in composition and consisted of a silt-sand-gravel-cobble mixture with an occasional large boulder (photo A-3). Typically, the material was “well graded” (evenly mixed) although along the banks of the creek, there was some layering from flood deposits and heavier percentages of fine materials.

After the rocks for each weir were in place, an impervious “geocomposite” fabric was spread on the upstream side of each one (photos A-6 and A-7). The purpose of the fabric was to reduce or prevent water from traveling underneath the large rocks and to encourage deposition of fine materials if

small leaks through the backfill did occur. The fabric was placed in various configurations and was held in place by the weight of the large rocks and by fill material.

The fabric consists of two layers of “16-ounce” geotextile (weight per square yard) bonded to each side of a 50-mil-thick (about 1/20th of an inch), impermeable polyvinylacetate membrane. The fabric was manufactured by Huesker Inc. (product number HGC-165016) and purchased directly from the company. About 500 square feet of material was installed at the Upper Stokes site. At Weir No. 1, where the diversion box is located and minimal seepage is preferred, the pool was fully lined. The upper Weir No. 2, primarily used for stabilization and low-flow fish passage, was only lined in the middle third.

2.2 CONSTRUCTION TIMELINE

Construction on the project began on the morning of October 8, 2003 with the excavation for the dewatering pipe trench. The last of the cleanup was completed on October 16. The weather was very good with seasonal temperatures and some rainfall. Creek flows stayed consistent and were estimated to range between 4 and 6 cfs. Revegetation will be completed in the spring of 2004 and will be monitored by OCD; informal site monitoring by the irrigator, OCD, and Reclamation will continue through the years.

The project was built in the following steps:

1. Installation of 125 feet of dewatering pipe around site of both weirs and the existing dam; Photo A-6.
2. Installation of ecology block cofferdam with plastic; electroshocking and removal of resident fish from site (1 day); Photos A-2 and A-25.
3. Deconstruction of log-and-plastic diversion dam.
4. Construction of Weir No. 1, including geocomposite liner and backfill (2 days); Photos A-3, A-4, A-5, A-6, and A-7.
5. Installation of diversion box and backfill (1 day); Photos A-8, A-9, A10, and A-11.
6. Installation of 18-inch-diameter conveyance pipe (1 day); Photos A-10 and A-12.
7. Deepen ditch and reinstall existing fishscreen. (1 day); Photos A-13, A-14, A-15, and A-16.
8. Construction of Weir No. 2 and backfill (1 day); Photos A-19 and A-20.
9. Completion of cleanup, regrading, removal of materials, etc.; initial revegetation (½ day); Photo A-18.

A walkthrough was conducted on October 14, 2003 by the landowner, irrigator, OCD, the contractor, and Reclamation. The group reached agreement on final grading and cleanup and

discussed revegetation, including the type and number of plants, and the schedule for work. A few “punchlist” (minor post-project completion work) items were identified, including removal of the rebar lifting eyes from the new diversion box, changing the attachment bolts for the trashrack to make it easier to remove, and placement of excess large rocks for instream habitat. The majority of punchlist items were completed by October 15, 2003; the remainder will be completed in the spring of 2004.

A final walkthrough of the project by the landowner, irrigator, OCD, and Reclamation is scheduled to occur sometime in July 2004. By that time, the new structures should have been tested by snowmelt and the highwater season. Continued monitoring of the double-drop weir (No. 1) is expected to be sure that it meets criteria. Modifications using hand tools may be required and will be accomplished prior to the final walkthrough. Any additional punchlist items or required repairs can be discussed at that time, including items related to revegetation.

Once it has been determined that the project has performed well and is delivering the required amount of water to the ditch, then the parties will sign a “turnover” agreement. This would establish that the maintenance of the project and any necessary repairs to the facilities would become the responsibility of the irrigator. If specific repairs or punchlist items are identified by that time, they would be fixed prior to signing. It is anticipated that the irrigator, OCD, and Reclamation would each sign the agreement.

Basic monitoring will occur over the next couple of years to make sure the project is functioning satisfactorily. In addition to that type of sporadic monitoring, Reclamation has proposed a long-term monitoring plan for the entire Beaver Creek watershed. The plan is being drafted by the Reclamation subbasin liaison, who is working with the landowners and various agencies to make sure the monitoring meets the needs of all concerned.

3. CONCLUSIONS

So far, the Upper Stokes Fish Passage Improvement project has been successful. It has yet to be tested by seasonal high flows. Weir No. 1 and the diversion box appear to deliver the required water flows to the ditch. It is expected that fish passage will meet all appropriate standards by June 2004. The maintenance of the new rock structures and headworks should be minimal for the landowner. The revegetation program will be completed in the spring and plant growth will be monitored. A turnover document will be signed by the landowner, OCD, and Reclamation after the first high-water season has passed and any necessary repairs or changes are made.

Upper Stokes Fish Passage Improvement Project

Appendix A. Construction Photographs (color)

All photographs by U.S. Bureau of Reclamation, Pacific Northwest Region, Boise, Idaho, PN-3400/Design Group, Boise, Idaho, October 2003 (except as noted)



Photo A-1. Looking upstream at original Upper Stokes Diversion Dam (photo taken July 2002).



Photo A-2. The ecology block and plastic cofferdam was set about 80 feet upstream from the original diversion dam.



Photo A-3. Looking downstream at the double-drop Weir No. 1; rock has been placed and tied into the right bank. This is the upper portion of the A-shaped weir. The suction pump in center picture is sending seepage water into the woods.



Photo A-4. Looking downstream at site of Weir No. 1 as technicians set elevation for the new diversion structure. The existing ditch was excavated about 12 inches to serve the lower elevation of the new headgate.



Photo A-5. Looking upstream at the left arm of Weir No. 1. Diversion structure is set in the center of the photo. The large rocks were brought in from a quarry about 30 miles east. Note the even slope of the rocks and lack of gaps between them.



Photo A-6. Looking upstream at Weir No. 1. A section of the dewatering pipe can be seen at the upper right; the seepage-pump line is at lower right; and the new diversion box is at the lower left.



Photo A-7. Downstream view of Weir No. 1; the non-permeable geomembrane has been installed but not fully covered.



Photo A-8. The intake side of the new diversion box, before placement. Both the trashrack and the grate(on top) are galvanized.



Photo A-9. Looking downstream, the new diversion structure (at middle right) has been set.



Photo A-10. Looking downstream at Weir No. 1, which has been lined with geotextile and then backfilled. The pipe trench has also been backfilled.



Photo A-10. Looking upstream across the right arm of Weir No. 1. The white PVC pipe is attached to the box's "stub." In a field modification to extend the irrigation further down the ditch, the corrugated black HDPE pipe was attached to the PVC pipe.



Photo A-12. The concrete protects and weights the transition between the PVC (white) and HDPE (black) irrigation pipes (see photo A-10). The fish screen is in the upper center of the photo, just above the black pipe.



Photo A-13. Along the diversion ditch, just downstream from the fish screen. The new ramp flume is shown near the center of the picture. This portion of the ditch have been cleared of vegetation and deepened.



Photo A-14. Downstream of the ramp flume, more cleaned-out ditch.



Photo A-15. The fish bypass channel, before installation of the fish bypass return pipe.



Photo A-16. The diversion pipe extension and the ditch transition at the fish screen. Note the benching of the ditch slopes.



Photo A-17. Looking across Beaver Creek to the left arm of Weir No. 2.



Photo A-18. Looking upstream at Weir No. 2 and the rebuilt stream bank.



Photo A-19. Weir No. 2 during low flow on November 15, 2003. The silt fence in the background will remain in place until the spring of 2004.



Photo A-20. Looking downstream from above Weir No. 2 on November 20. The upper position of Weir No. 1 is in the left-center of the picture. The headgate has been closed for the winter.



Photo A-21. Looking upstream from the exit of the fish bypass. Weir No. 1 is shown in the center of the picture.



Photo A-22. A closer view of Weir No. 1 on November 15.



Photo A-23. At Weir No. 1, the drop at the downstream portion is greater than designed. After highwater in 2004, if the bed of the pool has not been built up by deposited gravels, the drop will be adjusted.



Photo A-24. November high flow over the double-drop Weir No. 1, which is the diversion control structure.

Upper Lower Stokes Fish Passage Improvement Project

Appendix B. As-Built Drawings

Figure B-1. Location Map: Upper and Lower Stokes Diversions (1678-100-272) (not shown)

Figure B-2. Upper Stokes Diversion, Diversion Structure, Plan, Detail, and Section (1678-100-277)

Figure B-3. Upper Stokes Diversion, Diversion Profiles (1678-100-278)

Figure B-4. Upper Stokes Diversion, Cross Vane Weirs, Profiles and Sections (1678-100-279)

Figure B-5. Upper Stokes Diversion, Diversion Structure, Plan and Sections (1678-100-280)

Figure B-6. Upper Stokes Diversion, Diversion Structure, Plan Detail, and Section (1678-100-299)



Photo A-25. The Upper Stokes project job site during construction. The cofferdam is at left center.

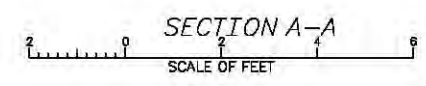
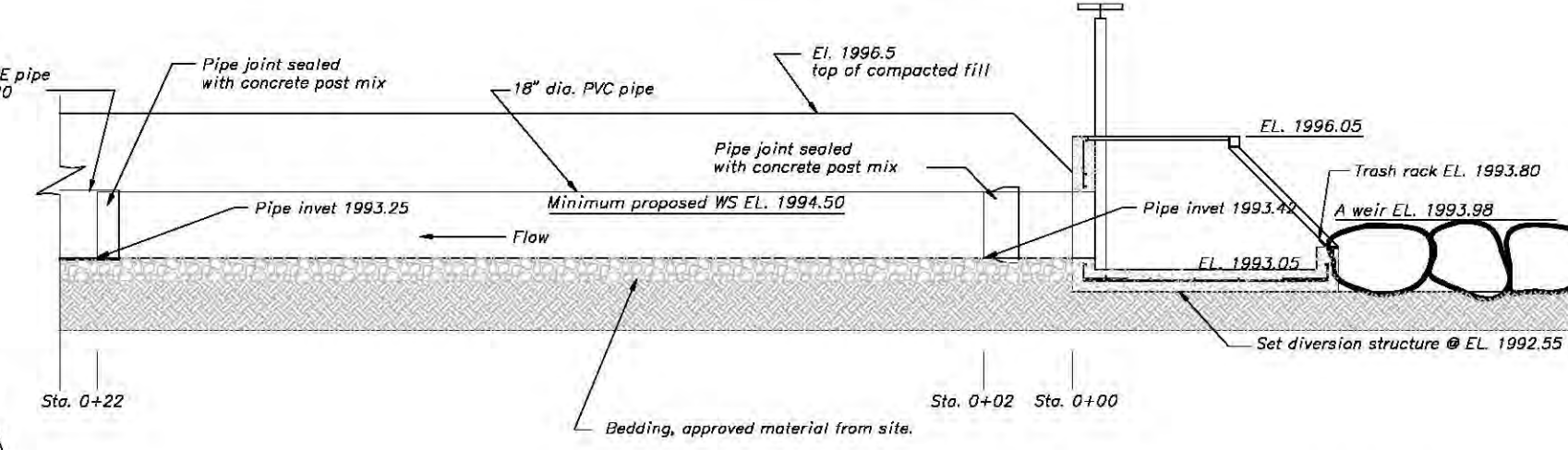
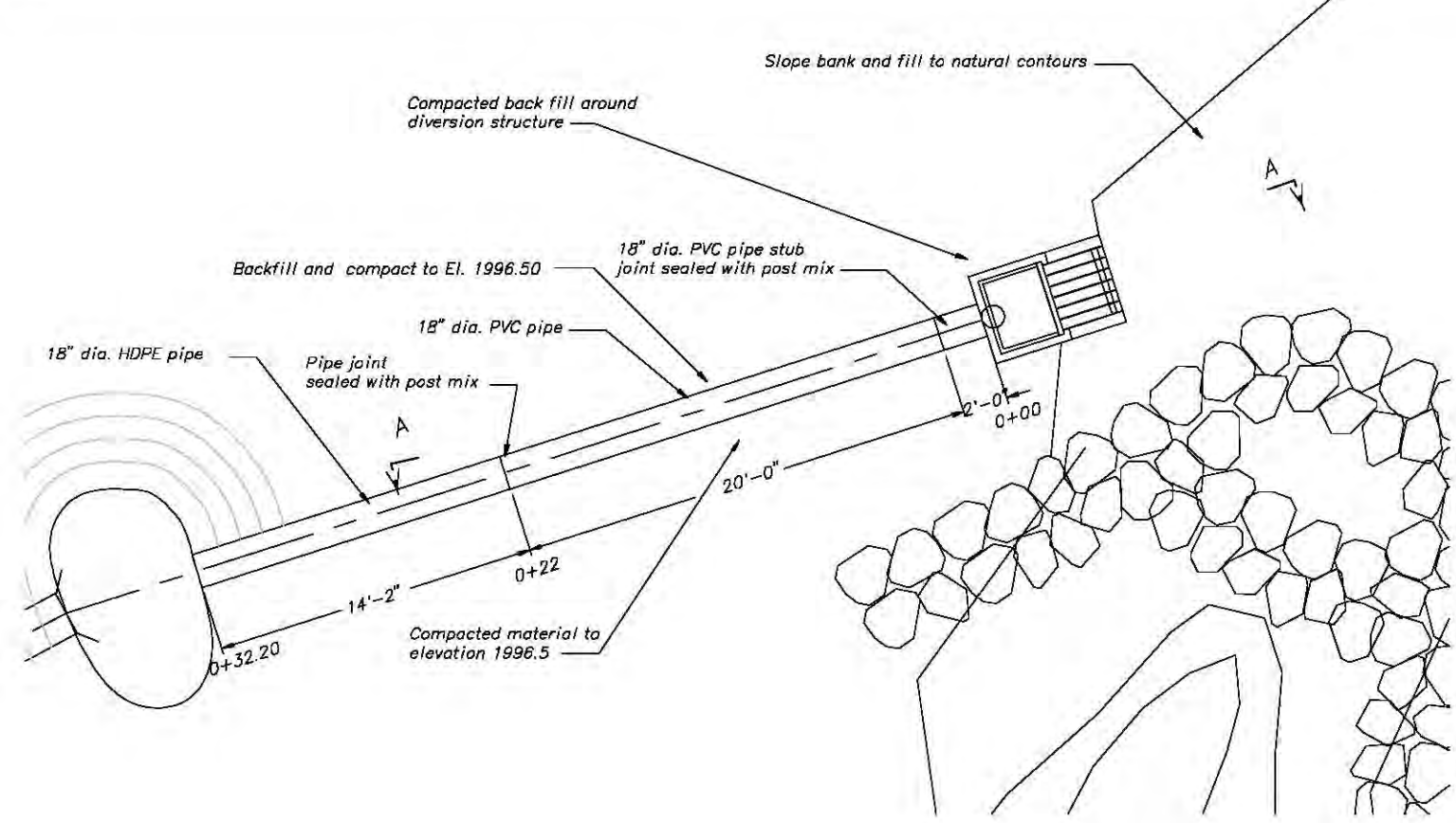
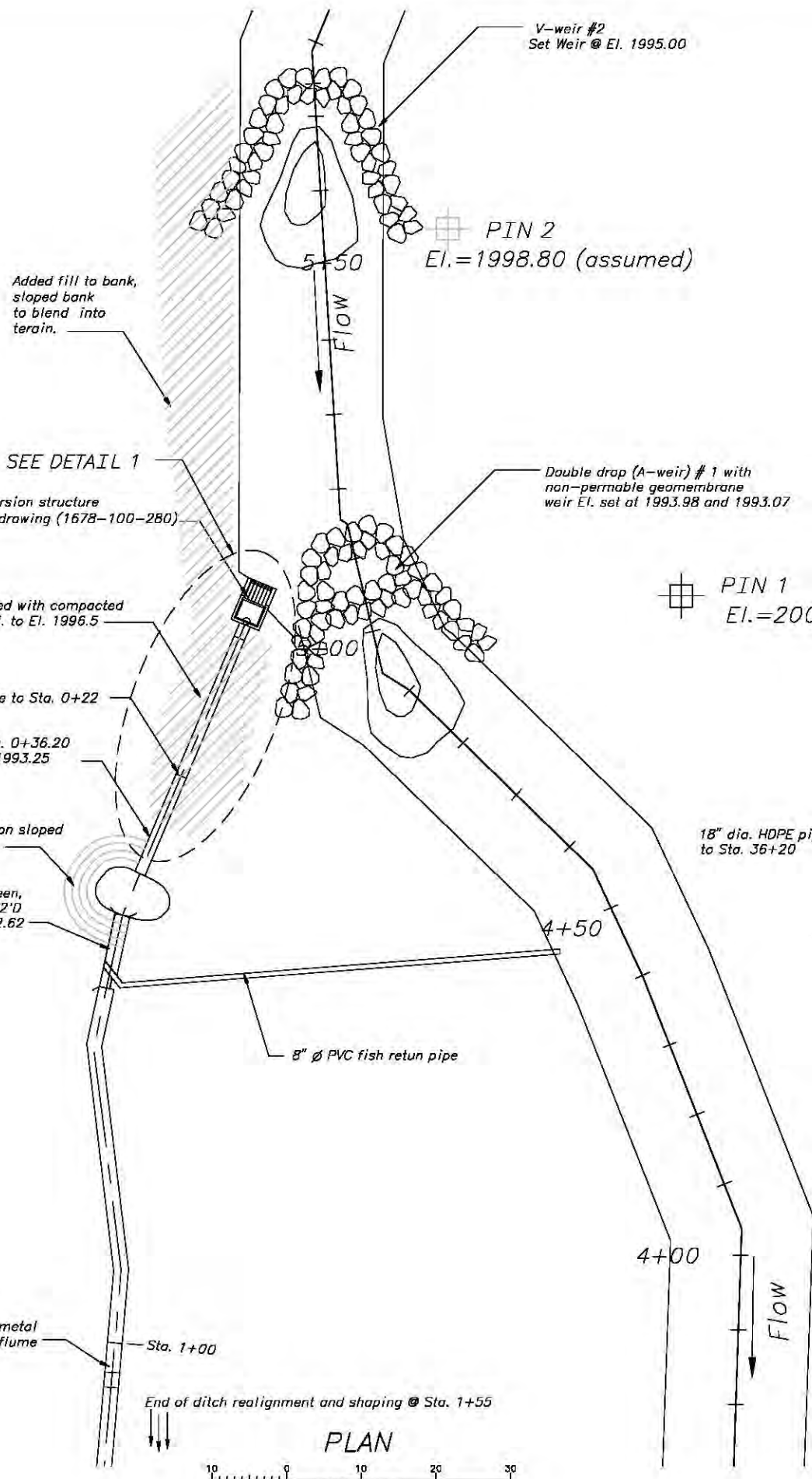

- NOTE:**
- Existing survey hubs are not to be damaged or removed by Contractor.
 - All materials including rocks, all pipe, the control structure, etc... are furnished by the District.
 - All layout and elevations will be provided by the Engineer.

REV. NO. 1	AS BUILT BY 100, JBW, 2004-02-27
ALWAYS THINK SAFETY	
UNITED STATES DEPARTMENT OF THE INTERIOR BUREAU OF RECLAMATION FCRPS HABITAT IMPROVEMENT PROGRAM METHOW RIVER SUBBASIN	
UPPER STOKES DIVERSION DIVERSION STRUCTURE PLAN, DETAIL, AND SECTION	
DESIGNED Jeff McLaughlin	CHECKED Gene Humbles
DRAWN Scott Weddle	TECH. APPROVAL Jeff McLaughlin
APPROVAL Dave Jennings PEER REVIEWER/PROGRAM MANAGER	
CADD SYSTEM AutoCAD Rev. 16.0 BOISE, IDAHO	CADD FILENAME 1678-100-277.DWG JANUARY 2003
SPECIFICATION # 1678-100-277	

DRAWN BY: JAW
PLOTTED BY: SWEDDLE

PROPOSED V-WEIR LOCATIONS

STATION	ELEVATION	DESCRIPTION
5+03	1993.07	Proposed double drop A-weir #1
5+12	1993.98	
5+73	1995.00	Proposed V-weir #2

* Elevation and Station are at the low point of V weir

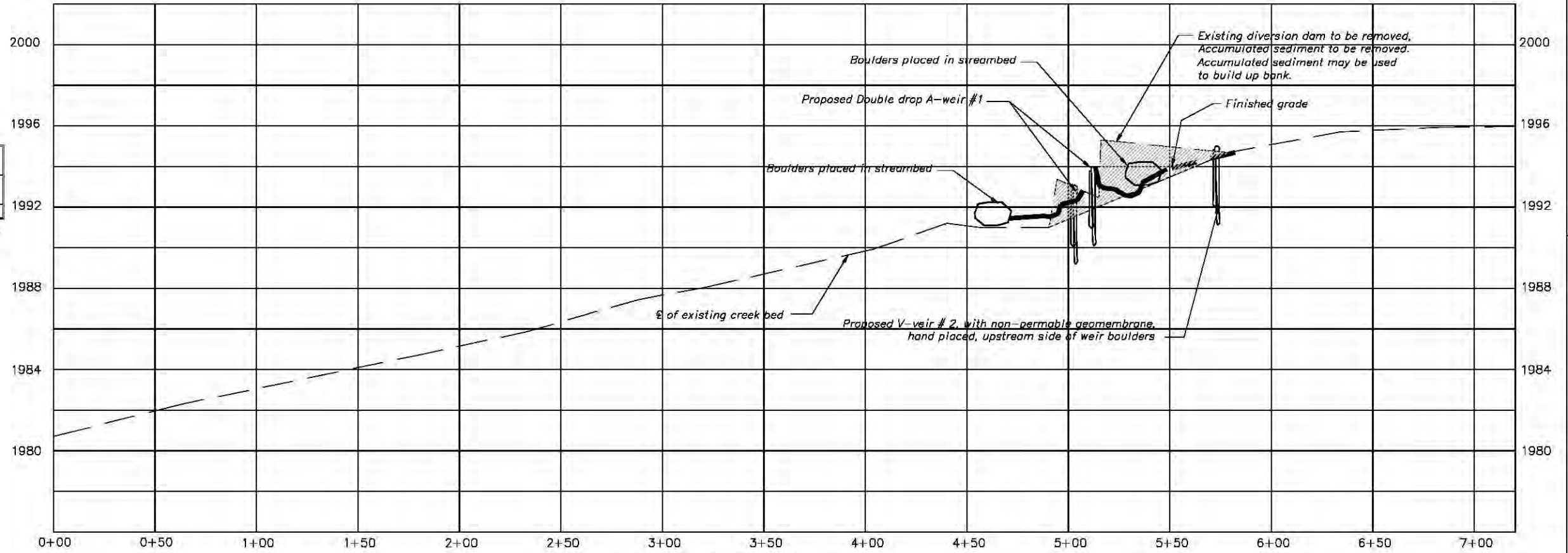

RIVER PROFILE

EXISTING DITCH PROFILE (OLD)		
STATION	ELEVATION	DESCRIPTION
0+00	1994.85	Invert @ Entrance
0+17	1994.90	Ditch invert
0+37	1994.31	Existing fishscreen invert (begin)
0+46	1994.31	Existing fish screen invert (end)
1+07	1993.23	Existing weir invert (begin)
1+10	1992.75	Existing weir invert (end)
1+87	1992.80	Ditch invert
1+14	1992.65	Ditch invert

CONSTRUCTED DITCH PROFILE (NEW)		
STATION	ELEVATION	DESCRIPTION
	1993.05	Bottom of diversion structure
0+00	1993.42	Begin 18" dia. PVC pipe
0+22	1993.25	End of 18" dia. PVC pipe
0+36.20	1993.25	End of 18" dia. HDPE pipe
0+42.20	1992.62	Fish screen invert (begin)
0+50.20	1992.60	Fish screen invert (end)
1+00	1992.49	Entrance of ramp flume (invert)
1+55	1992.50	End of ditch realignment

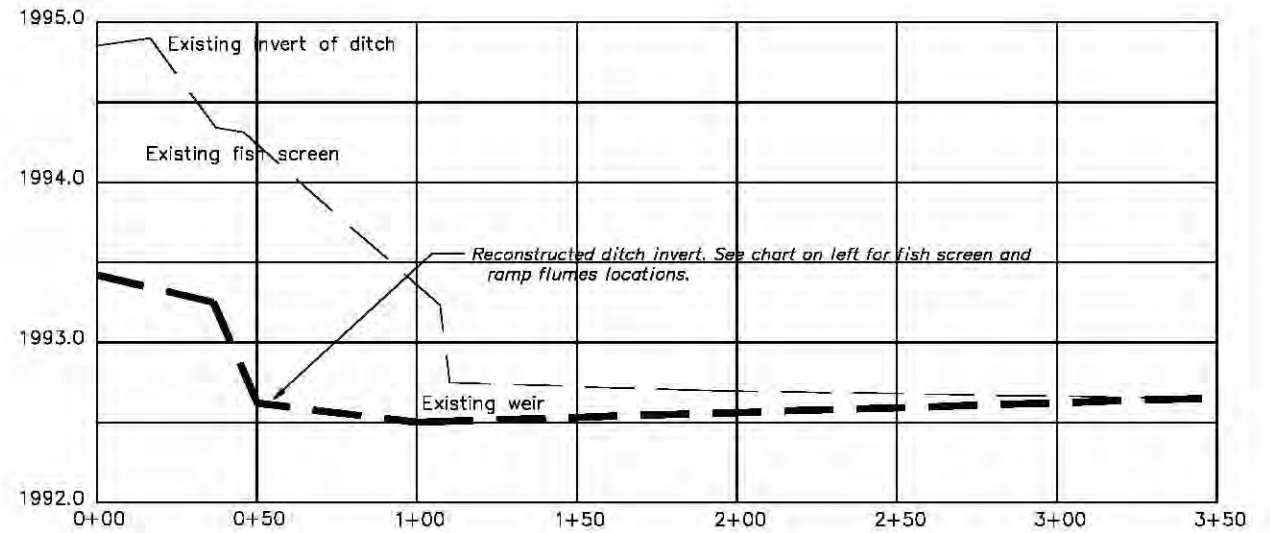

DITCH PROFILE

NOTE:
Ramp flume furnished and installed by others.

REV NO. 7

AS BUILT BY 100, JBW, 2004-02-27

ALWAYS THINK SAFETY

UNITED STATES
DEPARTMENT OF THE INTERIOR
BUREAU OF RECLAMATION
FCRPS HABITAT IMPROVEMENT PROGRAM
METHOW RIVER SUBBASIN

**UPPER STOKES DIVERSION
DIVERSION
PROFILES**

DESIGNED Jeff McLaughlin CHECKED Gene Humbles
DRAWN Scott Weddle TECH. APPROVAL Jeff McLaughlin
APPROVAL Dave Jennings
PERM REVIEWER/PROGRAM MANAGER

CADD SYSTEM AutoCAD Rev. 15.0 CADD FILENAME 1678-100-278.DWG
BOISE, IDAHO JANUARY 2003 1678-100-278

MARCH 24, 2004 10:20
 PLOTTED BY
 SWEDDLE

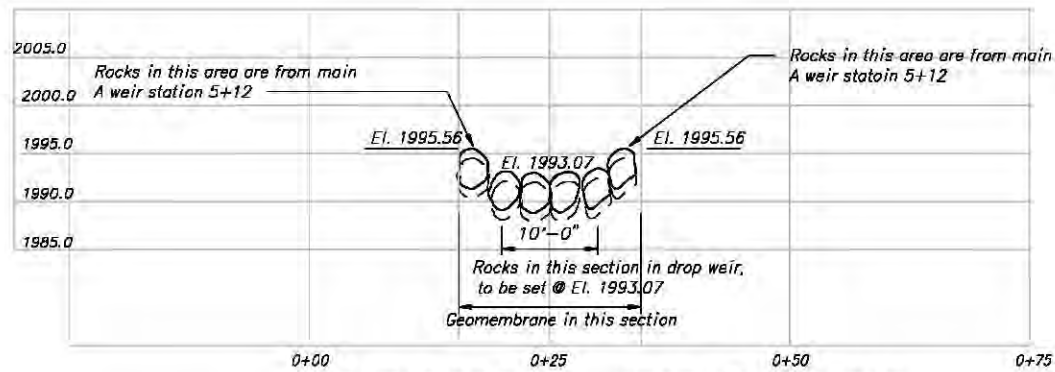

DOUBLE DROP A - WEIR #1 PROFILE
STATION 5+03

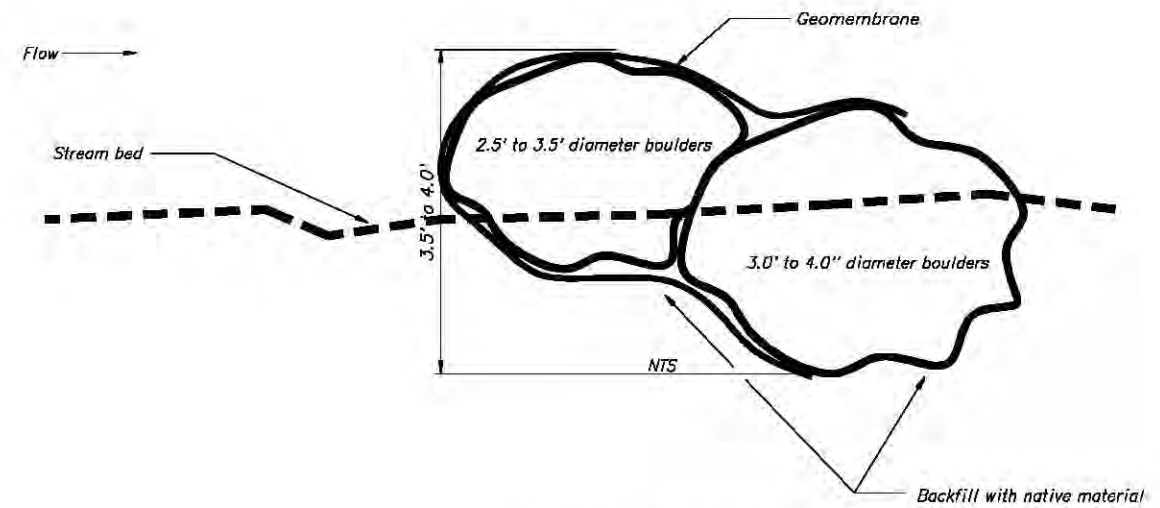
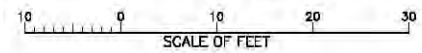

SECTION OF TYPICAL ROCK WEIR

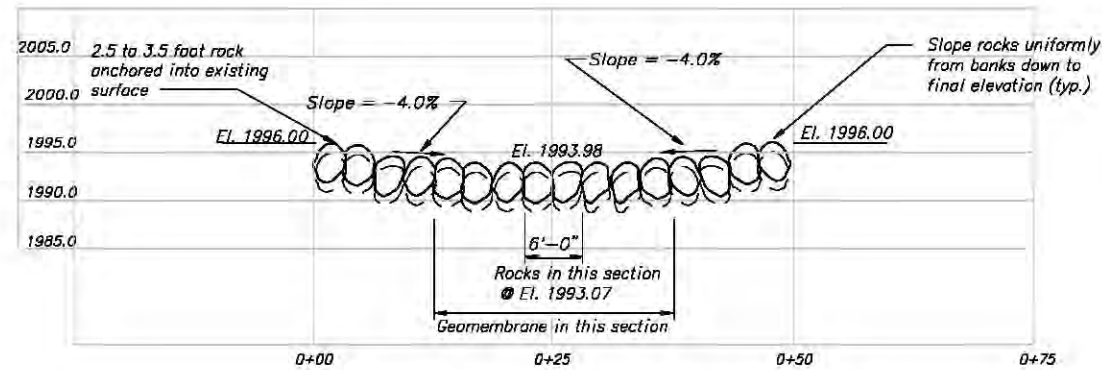

DOUBLE DROP A - WEIR #1 PROFILE
STATION 5+12

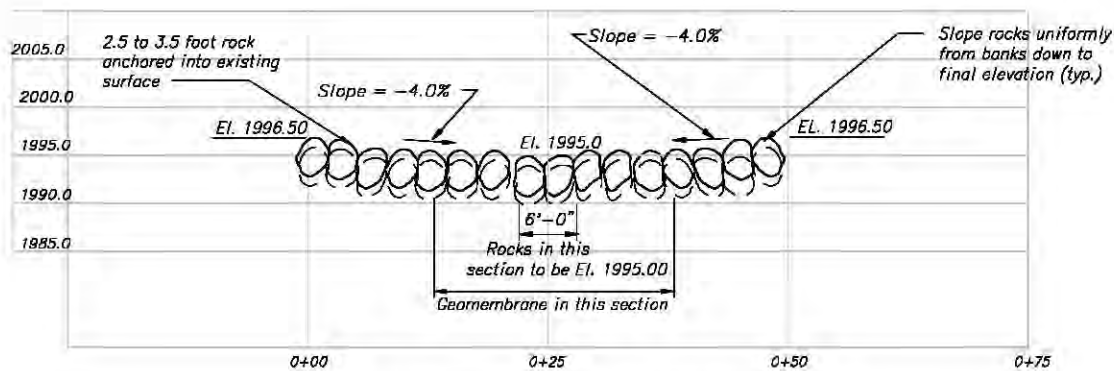
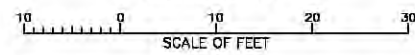

V - WEIR #2 PROFILE
STATION 5+73

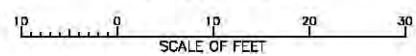

NOTES:

1. Local elevations used and are not based on sea level datum.
2. Rocks furnished by the District, approx. distance to point of use is 150 ft.

REV. NO. 1	AS BUILT BY 100, JBW, 2004-02-27
ALWAYS THINK SAFETY	
UNITED STATES DEPARTMENT OF THE INTERIOR BUREAU OF RECLAMATION FCRPS HABITAT IMPROVEMENT PROGRAM METHOW RIVER SUBBASIN UPPER STOKES CROSS VANE WEIRS PROFILES AND SECTION	
DESIGNED <u>Jeff McLaughlin</u>	CHECKED <u>Gene Humbles</u>
DRAWN <u>Scott Weddis</u>	TECH. APPROVAL <u>Jeff McLaughlin</u>
APPROVED <u>Dave Jennings</u> PEER REVIEWER/PROGRAM MANAGER	
CADD SYSTEM AutoCAD Rev. 16.0 BOISE, IDAHO	CADD FILENAME 1678-100-279.DWG JANUARY 2003
1678-100-279	

PRINTED BY: ADAM LUTZ
 PLOTTED BY:
 SWEEDLE

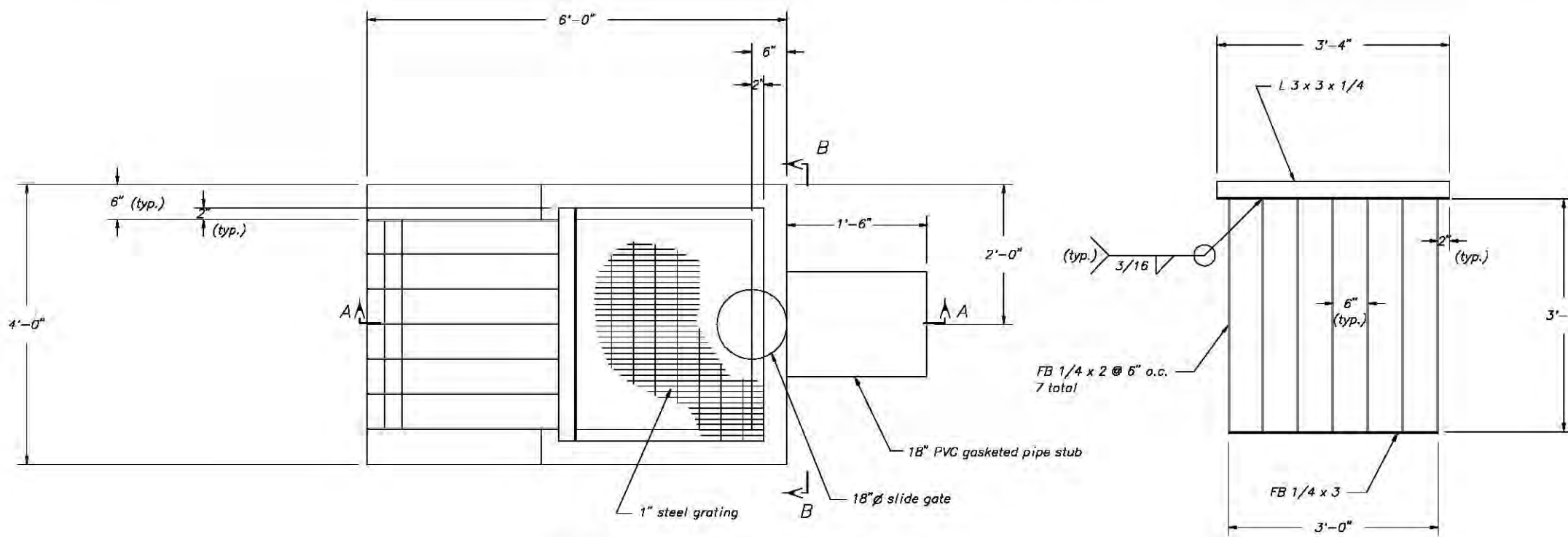

PLAN

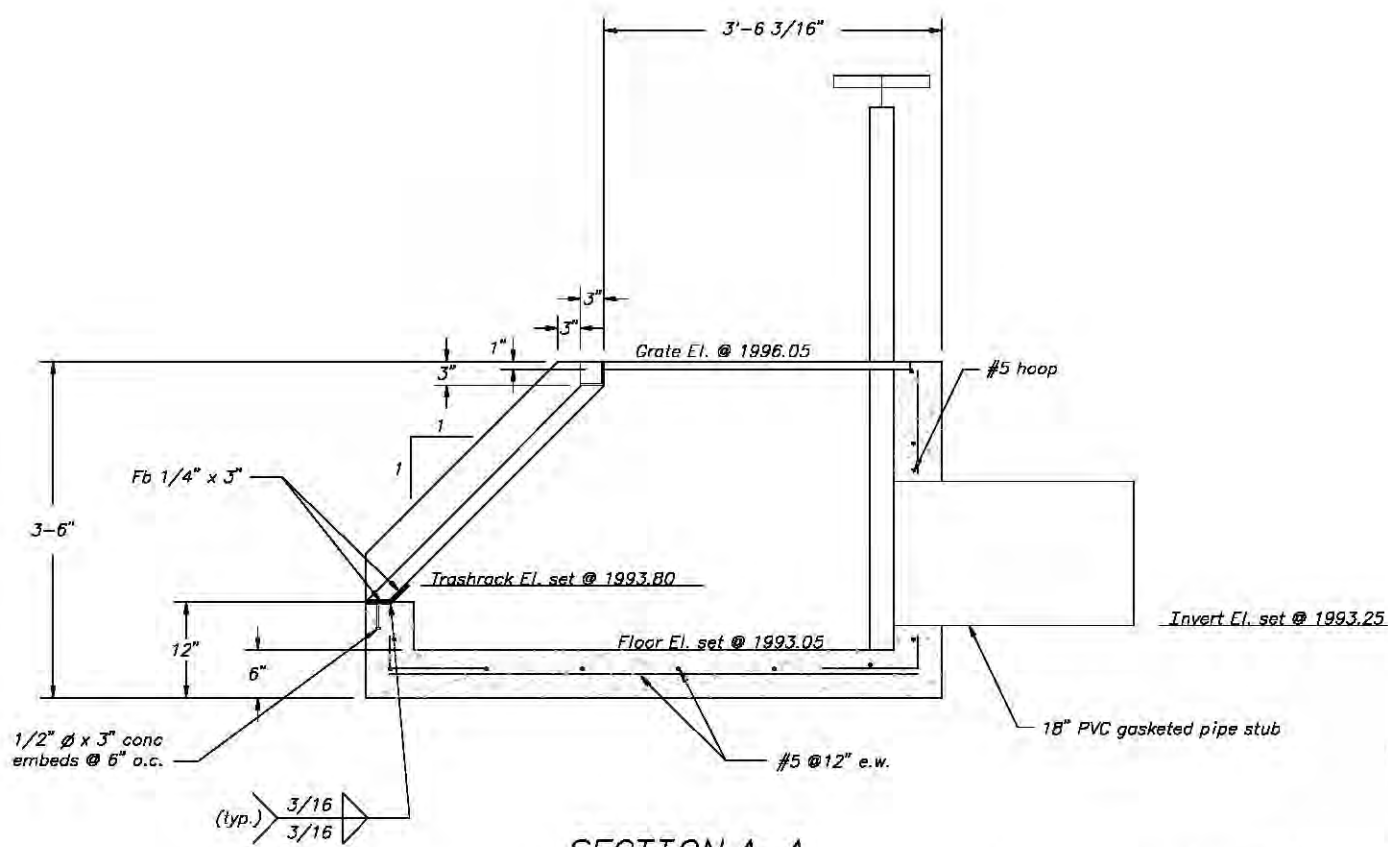
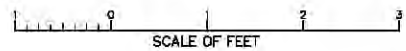

SECTION A-A

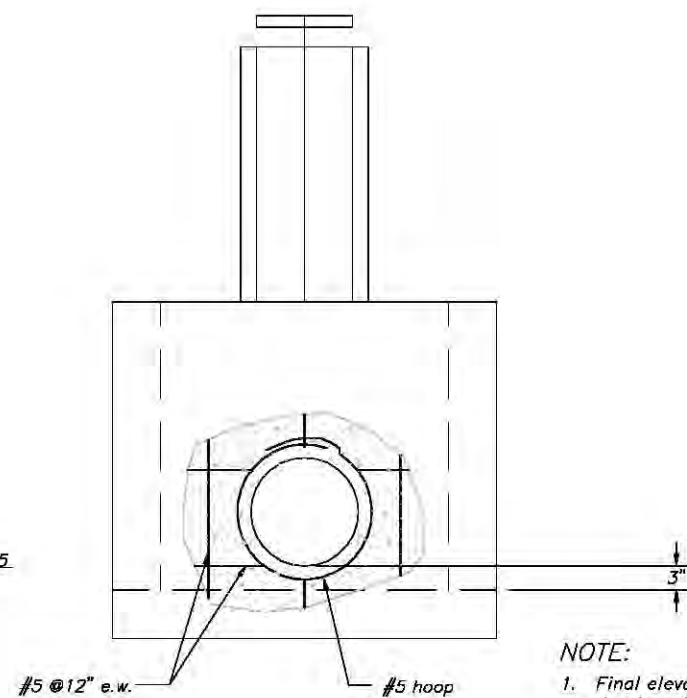
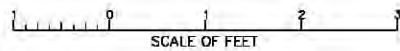

SECTION B-B

Headgate structure supplied by Others. Installed by Contractor.

NOTE:

1. Final elevation of headgate structure determined in the field. (Bottom set @ EL.1992.55)
2. Grate to have a tolerance of -.25" to allow grate to fit within design dimensions.
3. Add temporary lifting eyes or cables to structure.

REVISED	AS BUILT BY 100, JBW. 2004-02-27
1	
ALWAYS THINK SAFETY	
UNITED STATES DEPARTMENT OF THE INTERIOR BUREAU OF RECLAMATION FCRPS HABITAT IMPROVEMENT PROGRAM METHOW RIVER SUBBASIN UPPER STOKES DIVERSION DIVERSION STRUCTURE PLAN AND SECTIONS	
DESIGNED <u>Jeff McLaughlin</u>	CHECKED <u>Cene Humbles</u>
DRAWN <u>Scott Weddle</u>	TECH. APPROVAL <u>Jeff McLaughlin</u>
	APPROVED <u>Dave Jennings</u> PEER REVIEWER/PROGRAM MANAGER
CADD SYSTEM AutoCAD Rev. 15.0 BOISE, IDAHO	CADD FILENAME 1678-100-280.DWG JANUARY 2002
	1678-100-280

SPECIFICATION #

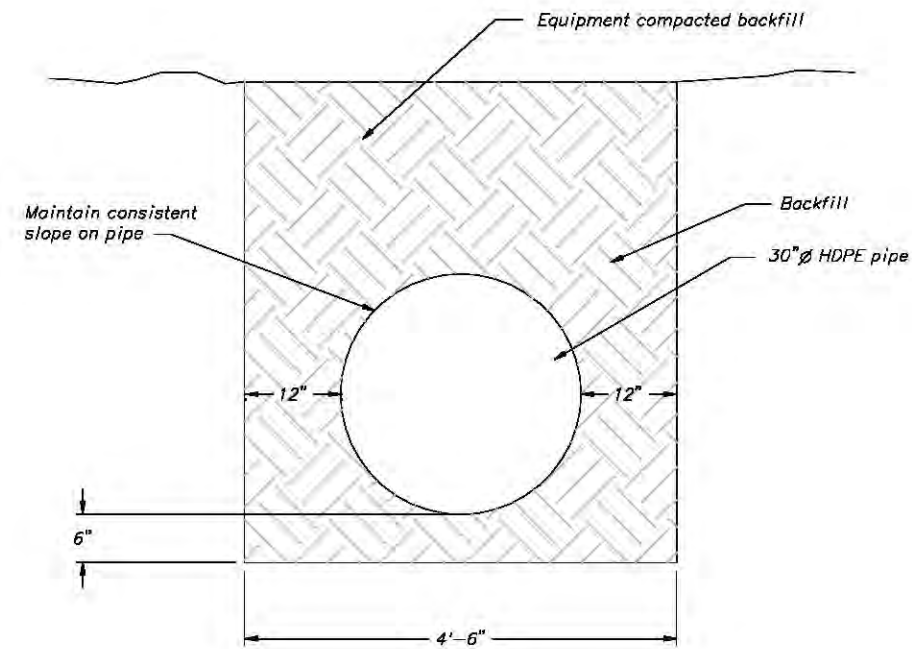
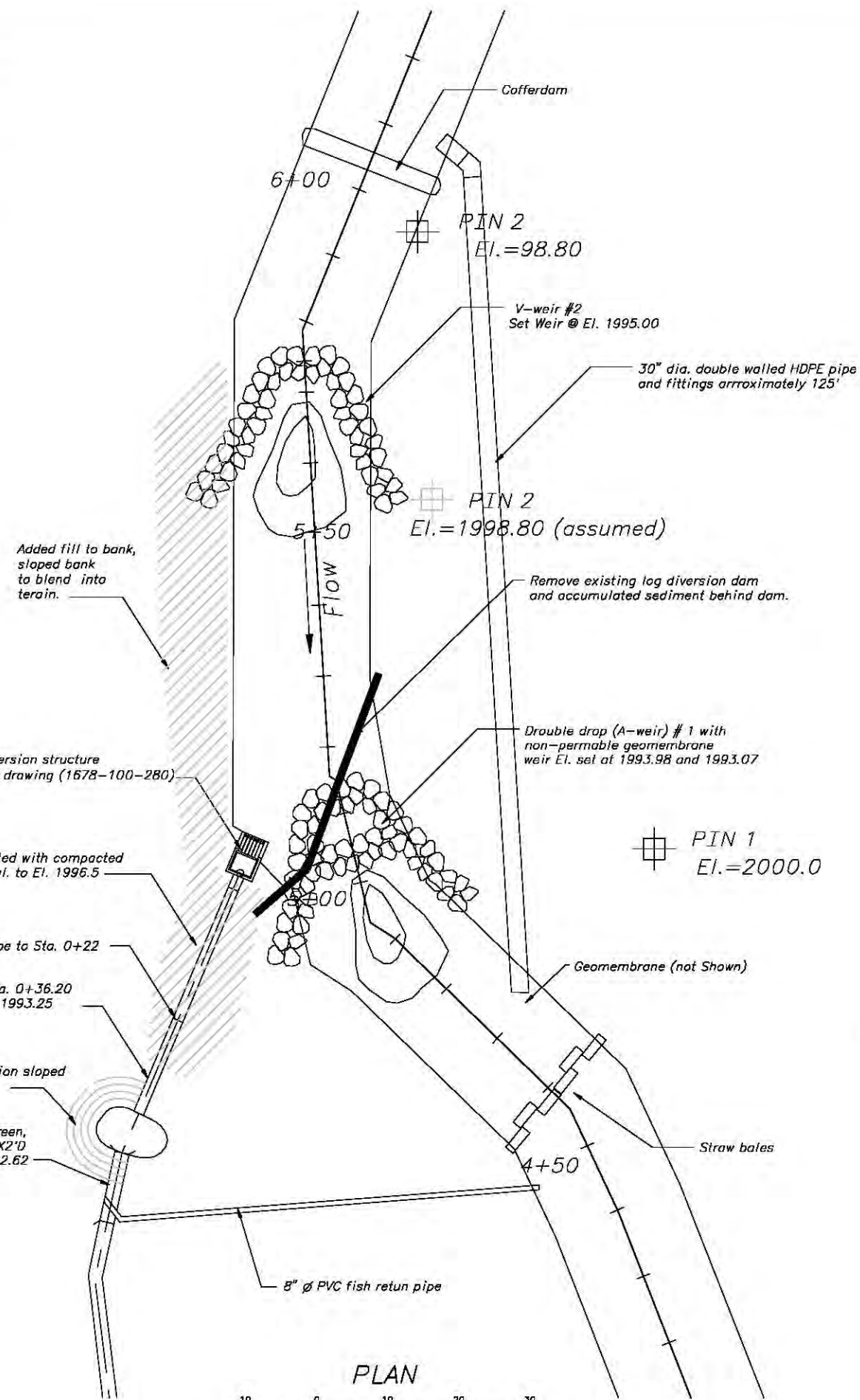

TYPICAL DEWATERING PIPE SECTION

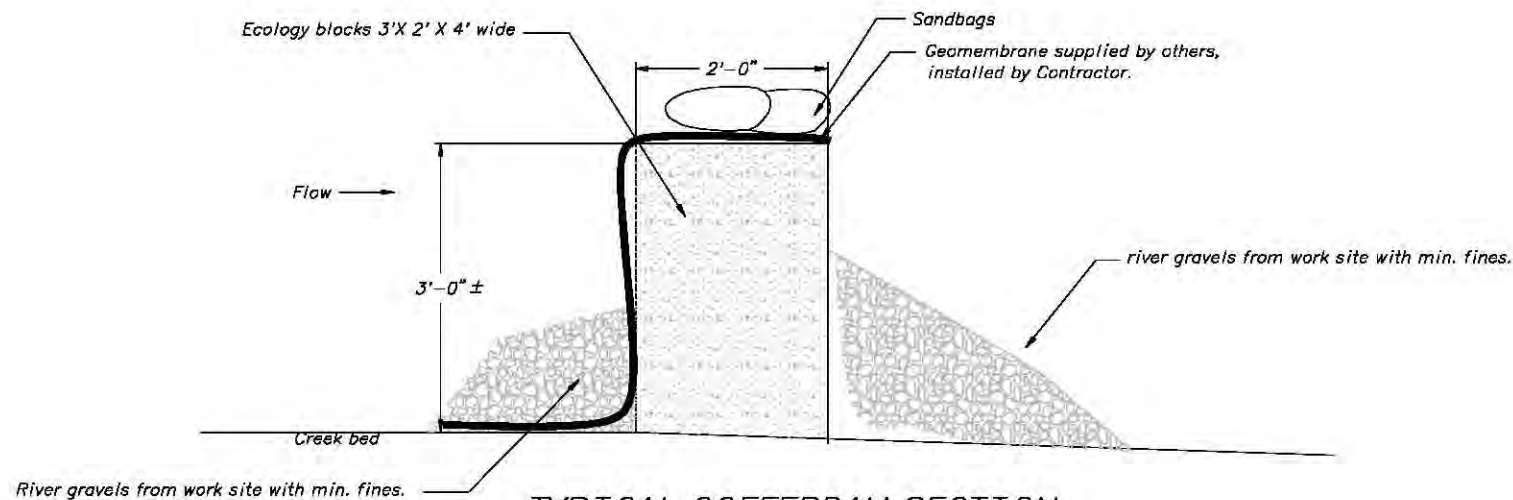
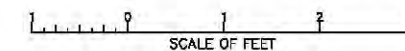

TYPICAL COFFERDAM SECTION

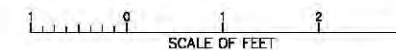

NOTE:

1. Actual alignment staked in field.
2. All fittings and pipe supplied by district/landowner.
3. Geotextile material for cofferdam also supplied by district/landowner.

REV. NO. 1	AS BUILT BY 100, JBW. 2004-02-27
ALWAYS THINK SAFETY	
UNITED STATES DEPARTMENT OF THE INTERIOR BUREAU OF RECLAMATION FCRPS HABITAT IMPROVEMENT PROGRAM METHOW RIVER SUBBASIN UPPER STOKES DIVERSION DIVERSION STRUCTURE PLAN, DETAIL, AND SECTION	
DESIGNED Jeff McLaughlin	CHECKED Gene Humbles
Additional fittings may be required.	
DRAWN Scott Weddle	TECH. APPROVAL Jeff McLaughlin
APPROVAL Dave Jennings	
PEER REVIEWER/PROGRAM MANAGER	
CADD SYSTEM AutoCAD Rev. 16.0	CADD FILENAME 1678-100-299.DWG
BOISE, IDAHO	JANUARY 2003
1678-100-299	
SPECIFICATION #	