

**UNITED STATES NUCLEAR REGULATORY COMMISSION
BOILING WATER REACTOR GENERIC FUNDAMENTALS EXAMINATION
SEPTEMBER 2008 --FORM A**

Please Print

Name: _____

Docket No.: _____

Facility: _____

Start Time: _____ Stop Time: _____

INSTRUCTIONS TO APPLICANT

Answer all the test items using the answer sheet provided, ensuring a single answer is marked for each test item. Each test item has equal point value. A score of at least 80% is required to pass this portion of the NRC operator licensing written examination. All examination papers will be collected 3.0 hours after the examination begins. This examination applies to a typical boiling water reactor (BWR) nuclear power plant.

SECTION	QUESTIONS	% OF TOTAL	SCORE
COMPONENTS	1 - 22		
REACTOR THEORY	23 - 36		
THERMODYNAMICS	37 - 50		
TOTALS	50		

All work performed on this examination is my own. I have neither given nor received aid.

Applicant's Signature

**RULES AND GUIDELINES FOR THE NRC
GENERIC FUNDAMENTALS EXAMINATION**

During the administration of this examination the following rules apply:

NOTE: The generic term "control rod" refers to the length of neutron absorber material that can be positioned by the operator to change core reactivity.

1. Print your name in the blank provided on the cover sheet of the examination.
2. Fill in your individual docket number.
3. Fill in the name of your facility.
4. Fill in your start and stop times at the appropriate time.
5. Two aids are provided for your use during the examination:
 - (1) An equations and conversions sheet contained within the examination copy, and
 - (2) Steam tables and Mollier Diagram provided by your proctor.
6. Place your answers on the answer sheet provided. Credit will only be given for answers properly marked on this sheet. Follow the instructions for filling out the answer sheet.
7. Scrap paper will be provided for calculations.
8. Cheating on the examination will result in the automatic forfeiture of this examination. Cheating could also result in severe penalties.
9. Restroom trips are limited. Only **ONE** examinee may leave the room at a time. In order to avoid the appearance or possibility of cheating, avoid all contact with anyone outside of the examination room.
10. After you have completed the examination, sign the statement on the cover sheet indicating that the work is your own and you have neither given nor received any assistance in completing the examination. Either pencil or pen may be used.
11. Turn in your examination materials, answer sheet on top, followed by the examination copy and the examination aids - steam table booklets, handouts, and scrap paper used during the examination.
12. After turning in your examination materials, leave the examination area, as defined by the proctor. If after leaving you are found in the examination area while the examination is in progress, your examination may be forfeited.

GENERIC FUNDAMENTALS EXAMINATION
EQUATIONS AND CONVERSIONS HANDOUT SHEET

EQUATIONS

$$\dot{Q} = \dot{m}c_p\Delta T$$

$$\dot{Q} = \dot{m}\Delta h$$

$$\dot{Q} = UA\Delta T$$

$$\dot{Q} \propto \dot{m}_{\text{Nat Circ}}^3$$

$$\Delta T \propto \dot{m}_{\text{Nat Circ}}^2$$

$$K_{\text{eff}} = 1/(1 - \rho)$$

$$\rho = (K_{\text{eff}} - 1)/K_{\text{eff}}$$

$$\text{SUR} = 26.06/\tau$$

$$\tau = \frac{\bar{\beta}_{\text{eff}} - \rho}{\lambda_{\text{eff}} \rho}$$

$$\rho = \frac{\ell^*}{\tau} + \frac{\bar{\beta}_{\text{eff}}}{1 + \lambda_{\text{eff}} \tau}$$

$$\ell^* = 1 \times 10^{-4} \text{ sec}$$

$$\lambda_{\text{eff}} = 0.1 \text{ sec}^{-1} \text{ (for small positive } \rho)$$

$$\text{DRW} \propto \phi_{\text{tip}}^2 / \phi_{\text{avg}}^2$$

$$P = P_o 10^{\text{SUR}(t)}$$

$$P = P_o e^{(t/\tau)}$$

$$A = A_o e^{-\lambda t}$$

$$\text{CR}_{\text{S/D}} = S/(1 - K_{\text{eff}})$$

$$\text{CR}_1(1 - K_{\text{eff}1}) = \text{CR}_2(1 - K_{\text{eff}2})$$

$$1/M = \text{CR}_1/\text{CR}_x$$

$$A = \pi r^2$$

$$F = PA$$

$$\dot{m} = \rho A \bar{v}$$

$$\dot{W}_{\text{pump}} = \dot{m}\Delta P v$$

$$E = IR$$

Thermal Efficiency = Net Work Out/Energy In

$$\frac{g(z_2 - z_1)}{g_c} + \frac{(\bar{v}_2^2 - \bar{v}_1^2)}{2g_c} + v(P_2 - P_1) + (u_2 - u_1) + (q - w) = 0$$

$$g_c = 32.2 \text{ lbm-ft/lbf-sec}^2$$

CONVERSIONS

$$1 \text{ Mw} = 3.41 \times 10^6 \text{ Btu/hr}$$

$$1 \text{ hp} = 2.54 \times 10^3 \text{ Btu/hr}$$

$$1 \text{ Btu} = 778 \text{ ft-lbf}$$

$$^\circ\text{C} = (5/9)(^\circ\text{F} - 32)$$

$$^\circ\text{F} = (9/5)(^\circ\text{C}) + 32$$

$$1 \text{ Curie} = 3.7 \times 10^{10} \text{ dps}$$

$$1 \text{ kg} = 2.21 \text{ lbm}$$

$$1 \text{ gal}_{\text{water}} = 8.35 \text{ lbm}$$

$$1 \text{ ft}^3_{\text{water}} = 7.48 \text{ gal}$$

**USNRC GENERIC FUNDAMENTALS EXAMINATION
SEPTEMBER 2008 BWR--FORM A**

QUESTION: 1

Which one of the following statements describes the operation of a reactor pressure vessel safety valve?

- A. An open safety valve will close when reactor pressure decreases enough for gravity and spring tension to overcome the effect of reactor pressure on the main valve disk.
- B. An open safety valve will close when the pilot valve senses a reduced reactor pressure and isolates reactor pressure to the main valve disk.
- C. When reactor pressure reaches the lift set point, the safety valve begins to open and will modulate to a position that is directly proportional to reactor pressure.
- D. When reactor pressure reaches the lift set point, a pilot valve closes to create a differential pressure across the main valve disk, which overcomes gravity and spring tension to open the valve.

**USNRC GENERIC FUNDAMENTALS EXAMINATION
SEPTEMBER 2008 BWR--FORM A**

QUESTION: 2

Refer to the drawing of a pneumatically-operated valve (see figure below). The valve actuator may be shown with or without air pressure applied to it.

Which one of the following describes the type of valve shown, and the fail position on loss of air to the actuator?

- | | <u>Valve Type</u> | <u>Fail Position</u> |
|----|-------------------|----------------------|
| A. | Gate | Open |
| B. | Gate | Closed |
| C. | Globe | Open |
| D. | Globe | Closed |

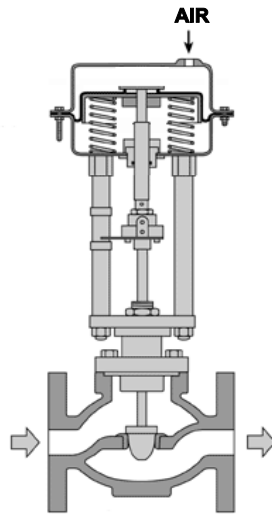

**USNRC GENERIC FUNDAMENTALS EXAMINATION
SEPTEMBER 2008 BWR--FORM A**

QUESTION: 3

A typical motor-operated valve (MOV) has just been opened from the main control room, and the breaker for the MOV has been opened. A plant operator has been directed to close the MOV locally for a surveillance test.

If the operator attempts to turn the MOV handwheel in the clockwise direction without first operating the clutch lever, which one of the following will occur?

- A. The handwheel will not turn, and the valve stem will not move.
- B. The handwheel will turn, but the valve stem will not move.
- C. The handwheel will turn, and the valve stem will move toward the closed position because the clutch is automatically engaged when the handwheel is turned.
- D. The handwheel will turn, and the valve stem will move toward the closed position because the clutch is automatically engaged when the breaker is opened.

QUESTION: 4

The change in pressure across a main steam line flow element is...

- A. directly proportional to the volumetric flow rate.
- B. inversely proportional to the volumetric flow rate.
- C. directly proportional to the mass flow rate.
- D. inversely proportional to the mass flow rate.

**USNRC GENERIC FUNDAMENTALS EXAMINATION
SEPTEMBER 2008 BWR--FORM A**

QUESTION: 5

Refer to the drawing of a reactor vessel differential pressure (D/P) level detection system that was calibrated at normal operating conditions (see figure below).

A reactor vessel cooldown has resulted in a decrease in reactor vessel pressure from 900 psia to 400 psia in one hour. Without density compensation of the level instrumentation, at the end of the cooldown, reactor vessel level indication would indicate _____ than actual level because the density of the water in the _____ has changed significantly.

- A. higher; reference leg
- B. higher; reactor vessel
- C. lower; reference leg
- D. lower; reactor vessel

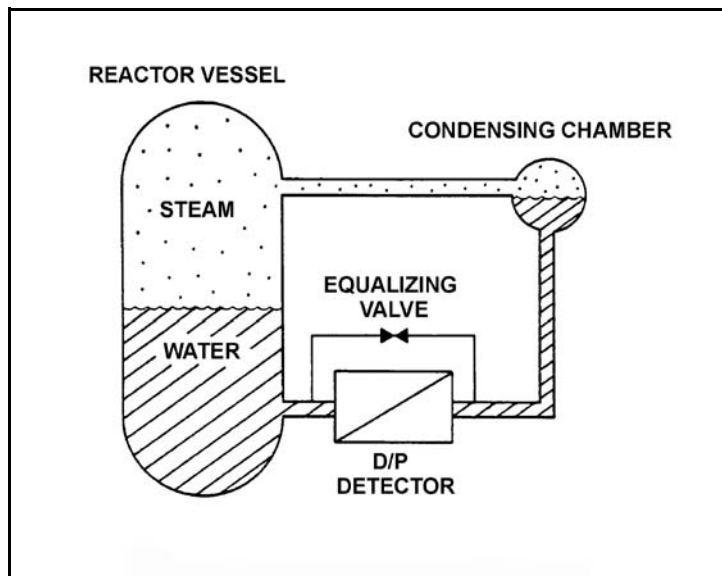

**USNRC GENERIC FUNDAMENTALS EXAMINATION
SEPTEMBER 2008 BWR--FORM A**

QUESTION: 6

Reed switches are being used in an electrical measuring circuit to monitor the position of a control rod in a nuclear reactor. The reed switches are mounted in a column below the reactor vessel such that the control rod drive shaft passes by the reed switches as the control rod is withdrawn.

Which one of the following describes the action that causes the electrical output of the measuring circuit to change as the control rod is withdrawn?

- A. An ac coil on the control rod drive shaft induces a voltage into each reed switch as the drive shaft passes by.
- B. A metal tab on the control rod drive shaft mechanically closes each reed switch as the drive shaft passes by.
- C. The primary and secondary coils of each reed switch attain maximum magnetic coupling as the drive shaft passes by.
- D. A permanent magnet on the control rod drive shaft attracts the movable contact arm of each reed switch as the drive shaft passes by.

QUESTION: 7

Which one of the following describes a characteristic of a self-reading pocket dosimeter?

- A. Provides dose rate indication in mR/hr.
- B. More sensitive to gamma radiation than beta radiation.
- C. Contains crystals that luminesce when exposed to ionizing radiation.
- D. Can be stored as an accurate record of lifetime radiation exposure.

**USNRC GENERIC FUNDAMENTALS EXAMINATION
SEPTEMBER 2008 BWR--FORM A**

QUESTION: 8

An emergency diesel generator (D/G) is operating as the only power source connected to an emergency bus. The governor of the D/G is directly sensing D/G _____ and will directly adjust D/G _____ flow to maintain a relatively constant D/G frequency.

- A. speed; air
- B. speed; fuel
- C. load; air
- D. load; fuel

**USNRC GENERIC FUNDAMENTALS EXAMINATION
SEPTEMBER 2008 BWR--FORM A**

QUESTION: 9

Refer to the drawing of a lube oil temperature control system (see figure below).

The temperature controller is a direct-acting proportional controller with a gain of 1.0. Which one of the following describes the effect of changing the gain to 2.0?

- A. Increases the range of lube oil temperatures that produces a proportional controller response.
- B. Increases the change in valve position resulting from a given change in lube oil temperature.
- C. Increases the difference between the controller setpoint and the lube oil temperature at steady state conditions.
- D. Increases the lube oil temperature deviation from setpoint required to produce a given controller output.

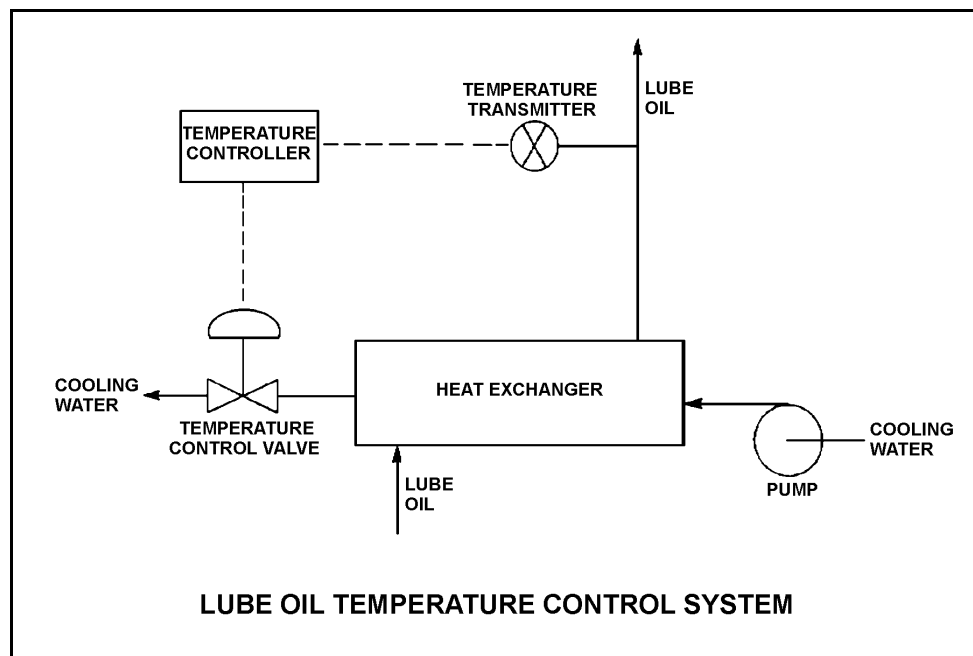

**USNRC GENERIC FUNDAMENTALS EXAMINATION
SEPTEMBER 2008 BWR--FORM A**

QUESTION: 10

Which one of the following describes gas binding of a centrifugal pump?

- A. Pump capacity is reduced due to the presence of steam or air in the pump impeller.
- B. Pump capacity is reduced due to windage losses between the pump impeller and pump casing.
- C. Pump motor current increases due to the compression of gases in the pump volute.
- D. Pump motor current increases due to the high head requirements for pumping a fluid saturated with dissolved gases.

QUESTION: 11

A centrifugal fire water pump takes a suction on an open storage tank and discharges through a fire hose. Which one of the following will cause the pump to operate at shutoff head?

- A. A firefighter inadvertently severs the fire hose.
- B. The fire hose becomes partially crimped in a fire door.
- C. Fire water storage tank level drops below the pump suction tap.
- D. A firefighter adjusts the fire hose nozzle spray pattern from “deluge” to “off”.

**USNRC GENERIC FUNDAMENTALS EXAMINATION
SEPTEMBER 2008 BWR--FORM A**

QUESTION: 12

Refer to the graph that represents the head-capacity characteristics for a single-speed centrifugal cooling water pump (see figure below).

Which one of the following lists a pair of parameters that could be represented by curves A and B?
(Note: NPSH = net positive suction head.)

- | <u>Curve A</u> | <u>Curve B</u> |
|---------------------|------------------|
| A. Pump Head | Available NPSH |
| B. Available NPSH | Required NPSH |
| C. Required NPSH | System Head Loss |
| D. System Head Loss | Pump Head |

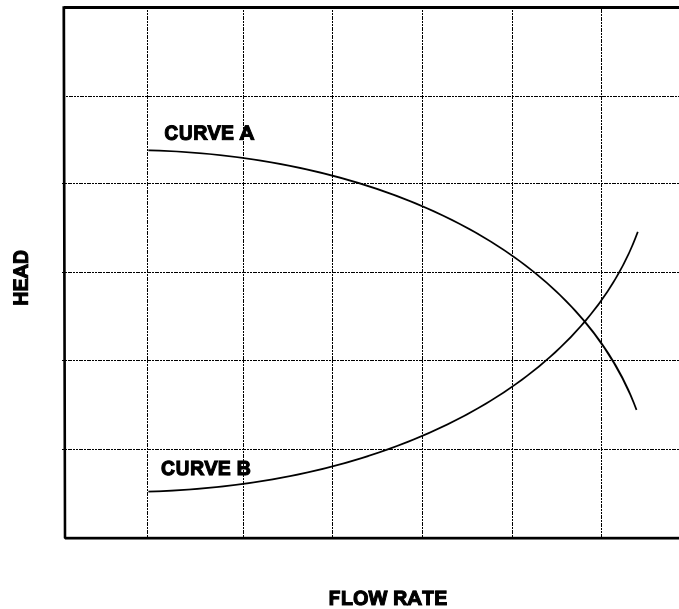

**USNRC GENERIC FUNDAMENTALS EXAMINATION
SEPTEMBER 2008 BWR--FORM A**

QUESTION: 13

Which one of the following describes the proper location for a relief valve that will be used to prevent exceeding the design pressure of a positive displacement pump and associated piping?

- A. On the pump suction piping upstream of the suction isolation valve.
- B. On the pump suction piping downstream of the suction isolation valve.
- C. On the pump discharge piping upstream of the discharge isolation valve.
- D. On the pump discharge piping downstream of the discharge isolation valve.

QUESTION: 14

Two identical 4,160 VAC three-phase induction motors are connected to identical radial-flow centrifugal pumps in identical but separate cooling water systems. Each motor is rated at 200 hp. The discharge valve for motor/pump A is fully open and the discharge valve for motor/pump B is fully closed.

When the motors are started under these conditions, the shorter time period required to reach a stable running current will be experienced by motor _____, and the higher stable running current will be experienced by motor _____.

- A. A; A
- B. A; B
- C. B; A
- D. B; B

**USNRC GENERIC FUNDAMENTALS EXAMINATION
SEPTEMBER 2008 BWR--FORM A**

QUESTION: 15

Two identical 1,000 MW electrical generators are operating in parallel supplying the same isolated electrical bus. The generator output breakers provide identical protection for the generators. Generator A and B output indications are as follows:

<u>Generator A</u>	<u>Generator B</u>
22 KV	22 KV
60.2 Hertz	60.2 Hertz
200 MW	200 MW
25 MVAR (out)	50 MVAR (out)

A malfunction causes the voltage regulator setpoint for generator B to slowly increase continuously toward a maximum of 25 KV. If no operator action is taken, generator A output current will...

- A. increase continuously until the output breaker for generator A trips on overcurrent.
- B. decrease continuously until the output breaker for generator B trips on overcurrent.
- C. initially decrease, and then increase until the output breaker for generator A trips on overcurrent.
- D. initially decrease, and then increase until the output breaker for generator B trips on overcurrent.

**USNRC GENERIC FUNDAMENTALS EXAMINATION
SEPTEMBER 2008 BWR--FORM A**

QUESTION: 16

Refer to the drawing of an operating parallel-flow lube oil heat exchanger (see figure below). Assume that lube oil (LO) inlet temperature is greater than cooling water (CW) inlet temperature.

Unlike a counter-flow heat exchanger, in a parallel-flow heat exchanger the _____ temperature can never be greater than the _____ temperature.

- A. LO outlet; CW inlet
- B. LO outlet; CW outlet
- C. CW outlet; LO inlet
- D. CW outlet; LO outlet

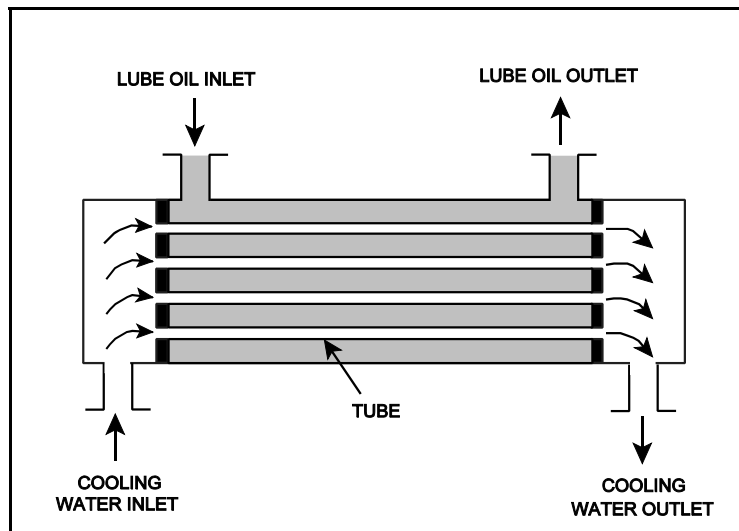

**USNRC GENERIC FUNDAMENTALS EXAMINATION
SEPTEMBER 2008 BWR--FORM A**

QUESTION: 17

During normal plant operation at 100% power, a main condenser develops an air leak that degrades vacuum at a rate of 1 inch Hg/min. Assuming the plant continues to operate at 100% power, condenser hotwell temperature will...

- A. increase because condensation of turbine exhaust steam is occurring at a higher temperature.
- B. increase because more work is being extracted from the steam by the turbine.
- C. decrease because condensation of turbine exhaust steam is occurring at a lower temperature.
- D. decrease because less work is being extracted from the steam by the turbine.

**USNRC GENERIC FUNDAMENTALS EXAMINATION
SEPTEMBER 2008 BWR--FORM A**

QUESTION: 18

Refer to the drawing of an operating lube oil heat exchanger (see figure below).

Given the following initial parameters:

Cooling water inlet temperature (T_{cw-in}) = 75°F
Cooling water outlet temperature (T_{cw-out}) = 95°F
Oil inlet temperature (T_{oil-in}) = 150°F
Oil outlet temperature ($T_{oil-out}$) = 120°F

Air introduction to the heat exchanger results in some of the heat exchanger tubes becoming uncovered. As a result, T_{cw-out} decreases to 91°F. Assume the inlet temperatures, mass flow rates, and specific heats of both fluids remain the same.

Which one of the following will be the resulting temperature of the oil exiting the heat exchanger ($T_{oil-out}$)?

- A. 126°F
- B. 130°F
- C. 134°F
- D. 138°F

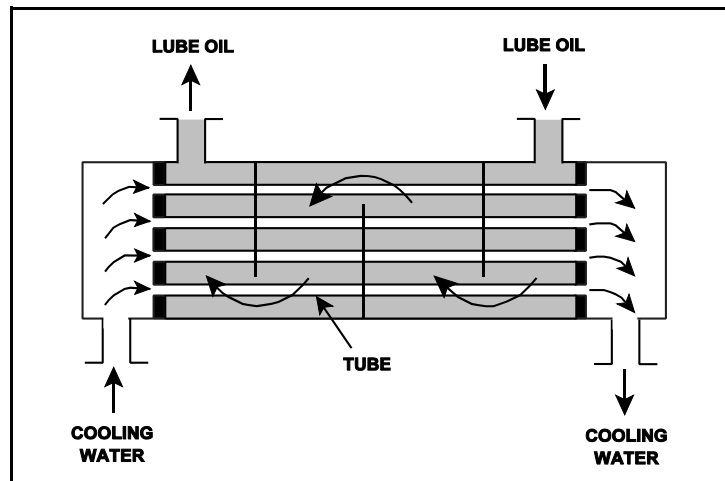

**USNRC GENERIC FUNDAMENTALS EXAMINATION
SEPTEMBER 2008 BWR--FORM A**

QUESTION: 19

The temperature of the water passing through a demineralizer must be controlled because excessively hot water will...

- A. increase the ion exchange rate for hydronium ions, thereby changing effluent pH.
- B. degrade the corrosion inhibitor applied to the inner wall of the demineralizer.
- C. result in excessive demineralizer retention element thermal expansion, thereby releasing resin.
- D. reduce the affinity of the demineralizer resin for ion exchange.

QUESTION: 20

If water containing positively-charged ionic impurities passes through a mixed-bed ion exchanger, the positively-charged ionic impurities will be removed by the _____ exchange resin, with the corresponding release of _____ ions into the water.

- A. anion; negative
- B. anion; positive
- C. cation; negative
- D. cation; positive

**USNRC GENERIC FUNDAMENTALS EXAMINATION
SEPTEMBER 2008 BWR--FORM A**

QUESTION: 21

Refer to the drawing of a valve motor control circuit (see figure below) for a valve that is currently fully closed and has a 10-second stroke time.

Note: Limit switch (LS) contacts are shown open regardless of valve position, but relay contacts are shown open/closed according to the standard convention for control circuit drawings.

Which one of the following describes the valve response if the control switch is taken to the “Open” position for two seconds and then released?

- A. The valve will not move.
- B. The valve will open fully.
- C. The valve will begin to open and then stop moving.
- D. The valve will begin to open and then close fully.

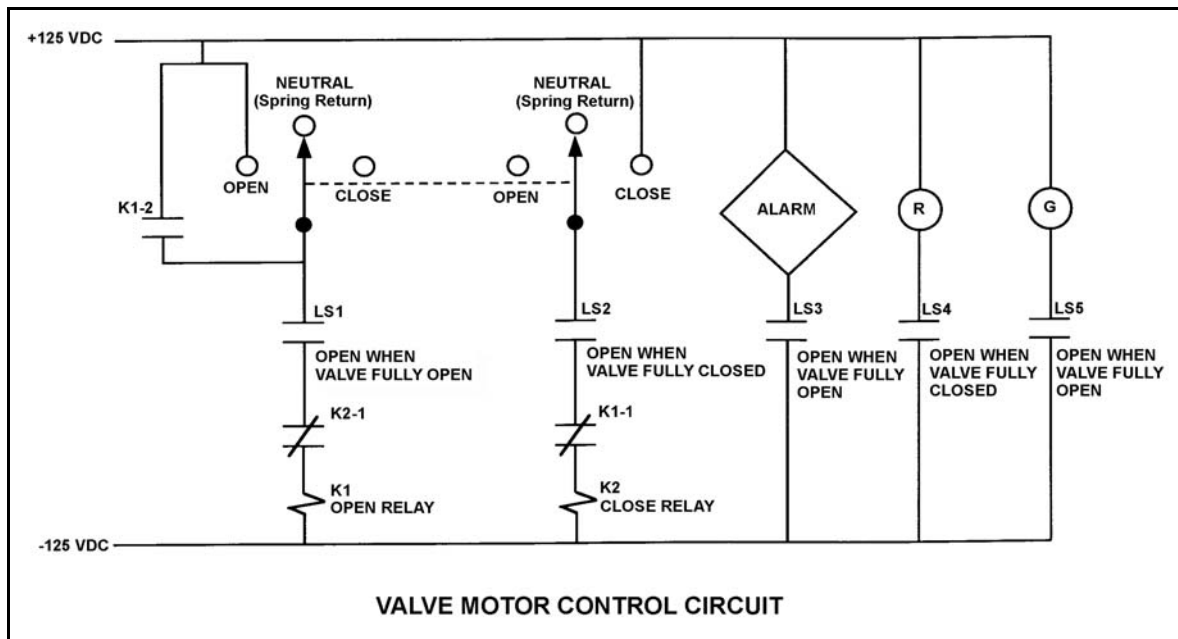

**USNRC GENERIC FUNDAMENTALS EXAMINATION
SEPTEMBER 2008 BWR--FORM A**

QUESTION: 22

Which one of the following is an unsafe practice if performed when working on or near energized electrical equipment?

- A. Use insulated tools to prevent inadvertent contact with adjacent equipment.
- B. Cover exposed energized circuits with insulating material to prevent inadvertent contact.
- C. Attach a metal strap from your body to a nearby neutral ground to ensure that you are grounded.
- D. Have a person standing by with the ability to remove you from the equipment in the event of an emergency.

QUESTION: 23

Which one of the following will decrease the ability of the coolant to moderate neutrons in a nuclear reactor operating at saturated conditions?

- A. Decreasing moderator temperature.
- B. Decreasing feedwater inlet temperature.
- C. Decreasing reactor vessel pressure.
- D. Increasing reactor recirculation system flow rate.

**USNRC GENERIC FUNDAMENTALS EXAMINATION
SEPTEMBER 2008 BWR--FORM A**

QUESTION: 24

Which one of the following does not affect core K_{eff} ?

- A. Core dimensions
- B. Core burnup
- C. Moderator-to-fuel ratio
- D. Installed neutron sources

QUESTION: 25

For an operating nuclear reactor, the “effective” delayed neutron fraction may differ from the delayed neutron fraction because, compared to prompt neutrons, delayed neutrons...

- A. are less likely to leak out of the reactor core, and they are less likely to cause fast fission.
- B. are less likely to cause fast fission, and they require more time to complete a neutron generation.
- C. require more time to complete a neutron generation, and they spend less time in the resonance absorption energy region.
- D. spend less time in the resonance absorption energy region, and they are less likely to leak out of the reactor core.

**USNRC GENERIC FUNDAMENTALS EXAMINATION
SEPTEMBER 2008 BWR--FORM A**

QUESTION: 26

The moderator temperature coefficient of reactivity generally becomes _____ negative over core life because the utilization of thermal neutrons _____.

- A. more; decreases
- B. less; decreases
- C. more; increases
- D. less; increases

QUESTION: 27

Which one of the following lists the moderator temperature coefficient (MTC), fuel temperature coefficient (FTC), and void coefficient (VC) in typical order of magnitude from most negative to least negative for a nuclear reactor at 50% power in the middle of a fuel cycle?

- A. FTC, VC, MTC
- B. FTC, MTC, VC
- C. VC, FTC, MTC
- D. VC, MTC, FTC

**USNRC GENERIC FUNDAMENTALS EXAMINATION
SEPTEMBER 2008 BWR--FORM A**

QUESTION: 28

Rod position indications indicate that a control rod is at position 16. When the control rod is moved to position 22, it is being...

- A. inserted 18 inches.
- B. withdrawn 18 inches.
- C. inserted 36 inches.
- D. withdrawn 36 inches.

QUESTION: 29

A control rod is positioned in a nuclear reactor with the following neutron flux parameters:

Core average thermal neutron flux	= 1×10^{12} n/cm ² -sec
Control rod tip thermal neutron flux	= 5×10^{12} n/cm ² -sec

If the control rod is slightly withdrawn such that the control rod tip is located in a thermal neutron flux of 1×10^{13} n/cm²-sec, then the differential control rod worth will increase by a factor of _____. (Assume the core average thermal neutron flux is constant.)

- A. 0.5
- B. 1.4
- C. 2.0
- D. 4.0

**USNRC GENERIC FUNDAMENTALS EXAMINATION
SEPTEMBER 2008 BWR--FORM A**

QUESTION: 30

A nuclear reactor has been operating at 25% power for five days when a scram occurs. Xe-135 will peak in approximately...

- A. 2 hours.
- B. 5 hours.
- C. 10 hours.
- D. 20 hours.

QUESTION: 31

A nuclear reactor is operating at 100% power with equilibrium core xenon-135 near the beginning of a fuel cycle when a scram occurs. When the reactor is taken critical 5 hours later, xenon distribution will be maximum at the _____ of the core.

- A. bottom and center
- B. bottom and outer circumference
- C. top and center
- D. top and outer circumference

**USNRC GENERIC FUNDAMENTALS EXAMINATION
SEPTEMBER 2008 BWR--FORM A**

QUESTION: 32

Why are burnable poisons installed in a nuclear reactor core?

- A. To shield reactor fuel from thermal neutron flux until later in core life
- B. To compensate for control rod burnout that occurs over core life
- C. To flatten the radial thermal neutron flux distribution at the end of core life
- D. To ensure a negative moderator temperature coefficient early in core life

QUESTION: 33

During an initial fuel load, the subcritical multiplication factor increases from 1.0 to 8.0. What is the current core K_{eff} ?

- A. 0.125
- B. 0.5
- C. 0.75
- D. 0.875

**USNRC GENERIC FUNDAMENTALS EXAMINATION
SEPTEMBER 2008 BWR--FORM A**

QUESTION: 34

A nuclear reactor is being started up with a stable positive 100-second period, and power is entering the intermediate range. Assuming no operator action, which one of the following describes the future response of reactor period?

- A. Prior to reaching the point of adding heat, the fuel temperature increase will add negative reactivity and reactor period will approach infinity.
- B. As heat production in the reactor exceeds ambient heat losses, the temperature of the fuel and moderator will increase, adding negative reactivity, and reactor period will approach infinity.
- C. The heat produced by the reactor when operating in the intermediate range is insufficient to raise the fuel or moderator temperatures, and reactor period remains nearly constant throughout the entire intermediate range.
- D. As heat production in the reactor exceeds ambient losses, positive reactivity added by the fuel temperature increase counteracts the negative reactivity added by the moderator temperature increase, and reactor period remains nearly constant throughout the entire intermediate range.

QUESTION: 35

A nuclear power plant is operating at 80% of rated power near the end of a fuel cycle. Which one of the following lists the typical method(s) used to add positive reactivity during a normal power increase to 100%?

- A. Withdrawal of deep control rods and increasing recirculation flow rate
- B. Withdrawal of deep control rods only
- C. Withdrawal of shallow control rods and increasing recirculation flow rate
- D. Withdrawal of shallow control rods only

**USNRC GENERIC FUNDAMENTALS EXAMINATION
SEPTEMBER 2008 BWR--FORM A**

QUESTION: 36

Which one of the following describes the core void fraction response that accompanies a reactor power increase from 20% to 30% using only control rod withdrawal?

- A. Decreases and stabilizes at a lower void fraction
- B. Increases and stabilizes at a higher void fraction
- C. Initially decreases, then increases and stabilizes at the initial void fraction
- D. Initially increases, then decreases and stabilizes at the initial void fraction

**USNRC GENERIC FUNDAMENTALS EXAMINATION
SEPTEMBER 2008 BWR--FORM A**

QUESTION: 37

Refer to the drawing of four tank differential pressure level detectors (see figure below).

The tanks are identical and are being maintained at 30 psia and a water level of 20 feet. They are surrounded by standard atmospheric pressure. The water in the tank and reference leg is at 70°F.

If each detector experiences a ruptured diaphragm, which detector(s) will cause indicated tank level to increase? (Assume actual tank water level remains constant.)

- A. No. 1 only
- B. No. 2 only
- C. No. 1 and 3
- D. No. 2 and 4

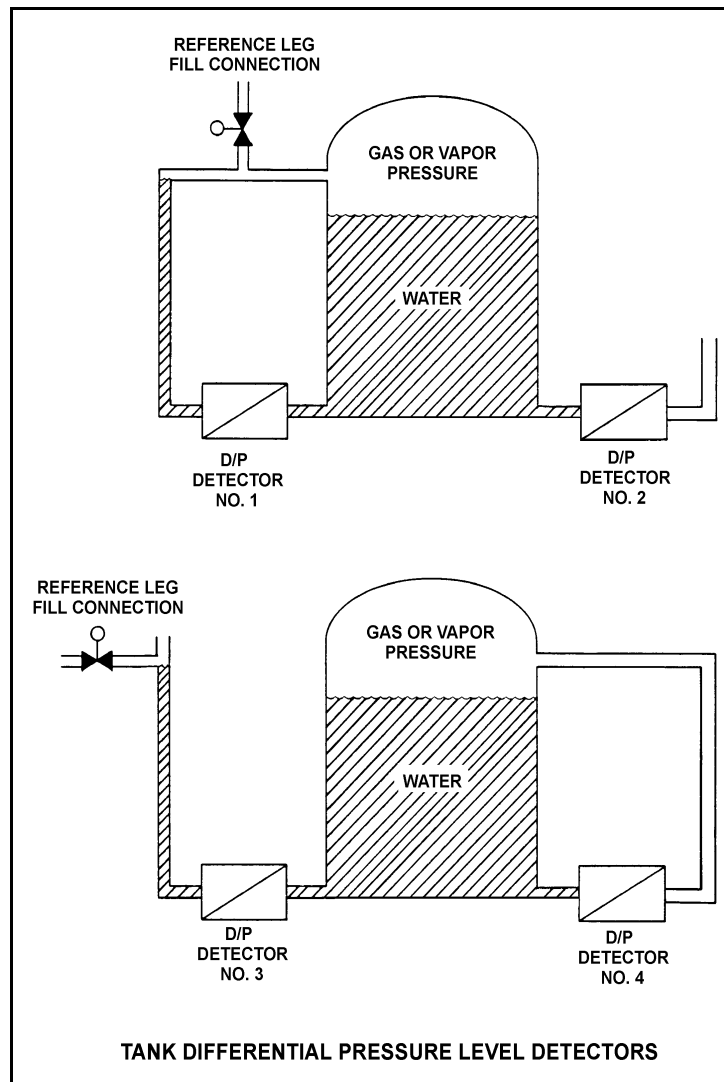

**USNRC GENERIC FUNDAMENTALS EXAMINATION
SEPTEMBER 2008 BWR--FORM A**

QUESTION: 38

A steam turbine exhausts to a steam condenser at 1.0 psia. The steam turbine is supplied with saturated steam at 900 psia at a flow rate of 200,000 lbm/hr. What is the approximate rate of condensate addition to the condenser hotwell in gallons per minute (gpm)?

- A. 400 gpm
- B. 2,400 gpm
- C. 4,000 gpm
- D. 24,000 gpm

QUESTION: 39

A nuclear power plant is operating at 90% of rated power. Which one of the following describes the effect of increasing cooling water flow rate through the main condenser?

- A. The saturation temperature in the main condenser decreases.
- B. The enthalpy of the condensate leaving the main condenser increases.
- C. The temperature of the cooling water leaving the main condenser increases.
- D. The total rate of heat transfer from the turbine exhaust steam to the cooling water decreases.

**USNRC GENERIC FUNDAMENTALS EXAMINATION
SEPTEMBER 2008 BWR--FORM A**

QUESTION: 40

If superheating of the inlet steam to the low pressure turbines is reduced, low pressure turbine work output will _____ and low pressure turbine exhaust steam moisture content will _____.

- A. increase; increase
- B. increase; decrease
- C. decrease; increase
- D. decrease; decrease

QUESTION: 41

A nuclear power plant is operating at full power when a 200 gpm reactor coolant leak occurs, which results in a reactor scram and initiation of emergency coolant injection. Reactor vessel pressure stabilizes at 900 psia and all centrifugal injection pumps are operating with all pump miniflow paths isolated. The shutoff heads for the pumps are as follows:

High pressure coolant injection (HPCI) pumps: 1,200 psia
Low pressure coolant injection (LPCI) pumps: 200 psia

Which pumps are currently threatened for operability and why?

- A. LPCI pumps due to pump overheating
- B. LPCI pumps due to motor overheating
- C. HPCI pumps due to pump overheating
- D. HPCI pumps due to motor overheating

**USNRC GENERIC FUNDAMENTALS EXAMINATION
SEPTEMBER 2008 BWR--FORM A**

QUESTION: 42

An 85 gpm leak to atmosphere has developed from a cooling water system that is operating at 100 psig. Which one of the following will be the approximate leak rate when system pressure has decreased to 50 psig?

- A. 33.3 gpm
- B. 42.5 gpm
- C. 51.7 gpm
- D. 60.1 gpm

QUESTION: 43

Which one of the following has the largest thermal conductivity?

- A. Fuel pellet
- B. Fuel clad
- C. Fuel rod fill gas
- D. Fission product gases

**USNRC GENERIC FUNDAMENTALS EXAMINATION
SEPTEMBER 2008 BWR--FORM A**

QUESTION: 44

Initially, subcooled water is flowing into a fuel assembly, with subcooled water exiting the fuel assembly several degrees hotter than when it entered, and no boiling is occurring in the fuel assembly. Assume that fuel assembly thermal power and water flow rate remain the same.

System pressure is decreased, causing some of the water in contact with the fuel rods to boil during transit through the fuel assembly. If the water exiting the fuel assembly remains subcooled, the average fuel temperature in the fuel assembly will be _____, and the temperature of the water exiting the fuel assembly will be _____.

- A. higher; the same
- B. higher; higher
- C. lower; the same
- D. lower; higher

QUESTION: 45

Given the following conditions:

10 lbm mixture of vapor and liquid
Steam quality = 20%
Pressure = 1,000 psia

Which one of the following is the approximate void fraction?

- A. 42%
- B. 48%
- C. 84%
- D. 96%

**USNRC GENERIC FUNDAMENTALS EXAMINATION
SEPTEMBER 2008 BWR--FORM A**

QUESTION: 46

Which one of the following describes the relationship between the feedwater mass flow rate entering the reactor vessel and the core mass flow rate at steady-state 100% reactor power?

- A. The mass flow rates are about the same as long as the reactor vessel downcomer level is constant.
- B. The mass flow rates are about the same as long as the reactor recirculation mass flow rate is constant.
- C. The feedwater mass flow rate is much smaller than the core mass flow rate because most of the core mass flow is returned to the reactor vessel downcomer by the steam separators.
- D. The feedwater mass flow rate is much larger than the core mass flow rate because the feedwater pump differential pressure is much larger than the core differential pressure.

QUESTION: 47

Thermal limits are established to protect the nuclear reactor core, and thereby protect the public during nuclear power plant operations which include...

- A. normal operations only.
- B. normal and abnormal operations only.
- C. normal, abnormal, and postulated accident operations only.
- D. normal, abnormal, postulated and unpostulated accident operations.

**USNRC GENERIC FUNDAMENTALS EXAMINATION
SEPTEMBER 2008 BWR--FORM A**

QUESTION: 48

If a nuclear reactor is operating above its Maximum Average Planar Linear Heat Generation Rate (MAPLHGR) prior to a loss of coolant accident, fuel pellet centerline temperature may reach 4,200°F and fuel cladding temperature may reach 2,300°F during the accident.

Which one of the following describes the likely clad rupture mechanism?

- A. Excessive fuel pellet expansion
- B. Excessive plastic strain in the clad
- C. Excessive embrittlement of the clad
- D. Excessive cadmium and iodine attack on the clad

QUESTION: 49

A step increase in reactor power results in a fuel rod surface temperature increase from 555°F to 585°F at steady state conditions. The fuel thermal time constant is 6 seconds.

Which one of the following is the approximate fuel rod surface temperature 6 seconds after the power change?

- A. 574°F
- B. 570°F
- C. 567°F
- D. 563°F

**USNRC GENERIC FUNDAMENTALS EXAMINATION
SEPTEMBER 2008 BWR--FORM A**

QUESTION: 50

A nuclear reactor is shut down for refueling. During the shutdown, a reactor vessel metal specimen is removed from the reactor vessel for testing. The specimen was last tested six years ago. During the subsequent six years, the reactor has completed several 18-month fuel cycles with an average power level of 85%.

The test determines that the nil-ductility transition (NDT) temperature of the specimen has remained unchanged at 44°F since it was last tested. Which one of the following conclusions is warranted?

- A. The test results are credible, however, the reactor vessel is more susceptible to brittle fracture now than six years ago.
- B. The test results are credible, however, the reactor vessel is less susceptible to brittle fracture now than six years ago.
- C. The test results are questionable because the specimen NDT temperature should have increased since it was last tested.
- D. The test results are questionable because the specimen NDT temperature should have decreased since it was last tested.

*****FINAL ANSWER KEY *****

**SEPTEMBER 2008 NRC GENERIC FUNDAMENTALS EXAMINATION
BOILING WATER REACTOR - ANSWER KEY**

<u>FORM A</u>	<u>FORM B</u>	<u>ANS.</u>	<u>FORM A</u>	<u>FORM B</u>	<u>ANS.</u>
1	15	A	26	40	D
2	16	C	27	41	D
3	17	B	28	42	B
4	18	A	29	43	D
5	19	B	30	44	B
6	20	D	31	45	A
7	21	B	32	46	A
8	22	B	33	47	D
9	23	B	34	48	B
10	24	A	35	49	A
11	25	D	36	50	B
12	26	B	37	1	A
13	27	C	38	2	A
14	28	C	39	3	A
15	29	D	40	4	C
16	30	D	41	5	A
17	31	A	42	6	D
18	32	A	43	7	B
19	33	D	44	8	D
20	34	D	45	9	C
21	35	B	46	10	C
22	36	C	47	11	C
23	37	C	48	12	C
24	38	D	49	13	A
25	39	A	50	14	C