

**UNITED STATES NUCLEAR REGULATORY COMMISSION
BOILING WATER REACTOR GENERIC FUNDAMENTALS EXAMINATION
OCTOBER 2001--FORM A**

Please Print

Name: _____

Facility: _____

Docket No.: _____

Start Time: _____ Stop Time: _____

INSTRUCTIONS TO APPLICANT

Answer all the test items using the answer sheet provided. Each item has equal point value. A score of at least 80% is required to pass this portion of the written licensing examination. All examination papers will be collected 4.0 hours after the examination starts. This examination applies to a typical boiling water reactor (BWR) power plant.

SECTION	QUESTIONS	% OF TOTAL	SCORE
COMPONENTS	1 - 44		
REACTOR THEORY	45 - 72		
THERMODYNAMICS	73 - 100		
TOTALS	100		

All work done on this examination is my own. I have neither given nor received aid.

Applicant's Signature

**RULES AND GUIDELINES FOR THE
GENERIC FUNDAMENTALS EXAMINATION**

During the administration of this examination the following rules apply:

NOTE: The generic term "control rod" refers to the length of neutron absorber material that can be positioned by the operator to change core reactivity.

1. Print your name in the blank provided on the cover sheet of the examination.
2. Fill in the name of your facility.
3. Fill in your individual docket number.
4. Fill in your start and stop times at the appropriate time.
5. Two aids are provided for your use during the examination:
 - (1) An equations and conversions sheet contained within the examination copy, and
 - (2) Steam tables provided by your proctor.
6. Place your answers on the answer sheet provided. Credit will only be given for answers properly marked on this sheet. Follow the instructions for filling out the answer sheet.
7. Scrap paper will be provided for calculations.
8. Cheating on the examination will result in the automatic forfeiture of this examination. Cheating could also result in severe penalties.
9. Restroom trips are limited. Only **ONE** examinee may leave the room at a time. In order to avoid the appearance or possibility of cheating, avoid all contact with anyone outside of the examination room.
10. After you have completed the examination, sign the statement on the cover sheet indicating that the work is your own and you have neither given nor received any assistance in completing the examination.
11. Turn in your examination materials, answer sheet on top, followed by the examination booklet, then examination aids - steam table booklets, handouts, and scrap paper used during the examination.
12. After turning in your examination materials, leave the examination area, as defined by the proctor. If after leaving you are found in the examination area while the examination is in progress, your examination may be forfeited.

GENERIC FUNDAMENTALS EXAMINATION
EQUATIONS AND CONVERSIONS HANDOUT SHEET

EQUATIONS

$$\dot{Q} = \dot{m}c_p\Delta T$$

$$\dot{Q} = \dot{m}\Delta h$$

$$\dot{Q} = UA\Delta T$$

$$\dot{Q} \propto \dot{m}_{\text{Nat Circ}}^3$$

$$\Delta T \propto \dot{m}_{\text{Nat Circ}}^2$$

$$K_{\text{eff}} = 1/(1 - \rho)$$

$$\rho = (K_{\text{eff}} - 1)/K_{\text{eff}}$$

$$\text{SUR} = 26.06/\tau$$

$$\tau = \frac{\bar{\beta} - \rho}{\lambda_{\text{eff}} \rho}$$

$$\rho = \frac{\ell^*}{\tau} + \frac{\bar{\beta}}{1 + \lambda_{\text{eff}}\tau}$$

$$\ell^* = 1 \times 10^{-4} \text{ seconds}$$

$$\lambda_{\text{eff}} = 0.1 \text{ seconds}^{-1}$$

$$\text{DRW} \propto \phi_{\text{tip}}^2 / \phi_{\text{avg}}^2$$

$$P = P_o 10^{\text{SUR}(t)}$$

$$P = P_o e^{(t/\tau)}$$

$$A = A_o e^{-\lambda t}$$

$$\text{CR}_{\text{S/D}} = S/(1 - K_{\text{eff}})$$

$$\text{CR}_1(1 - K_{\text{eff}1}) = \text{CR}_2(1 - K_{\text{eff}2})$$

$$1/M = \text{CR}_1/\text{CR}_X$$

$$A = \pi r^2$$

$$F = PA$$

$$\dot{m} = \rho A \bar{v}$$

$$\dot{W}_{\text{Pump}} = \dot{m}\Delta P v$$

$$E = IR$$

$$\text{Eff.} = \text{Net Work Out}/\text{Energy In}$$

$$v(P_2 - P_1) + \frac{(\bar{v}_2^2 - \bar{v}_1^2)}{2g_c} + \frac{g(z_2 - z_1)}{g_c} = 0$$

$$g_c = 32.2 \text{ lbm-ft/lbf-sec}^2$$

CONVERSIONS

$$1 \text{ Mw} = 3.41 \times 10^6 \text{ Btu/hr}$$

$$1 \text{ hp} = 2.54 \times 10^3 \text{ Btu/hr}$$

$$1 \text{ Btu} = 778 \text{ ft-lbf}$$

$$^\circ\text{C} = (5/9)(^\circ\text{F} - 32)$$

$$^\circ\text{F} = (9/5)(^\circ\text{C}) + 32$$

$$1 \text{ Curie} = 3.7 \times 10^{10} \text{ dps}$$

$$1 \text{ kg} = 2.21 \text{ lbm}$$

$$1 \text{ gal}_{\text{water}} = 8.35 \text{ lbm}$$

$$1 \text{ ft}^3_{\text{water}} = 7.48 \text{ gal}$$

**USNRC GENERIC FUNDAMENTALS EXAMINATION
OCTOBER 2001 BWR--FORM A**

QUESTION: 1

A vertical safety valve with a 2-inch diameter disk has a compressed spring applying 2,400 lbf to the top of the valve disk in opposition to system pressure. Which one of the following is the approximate system pressure at which the safety valve will open?

- A. 95 psig
- B. 191 psig
- C. 382 psig
- D. 764 psig

USNRC GENERIC FUNDAMENTALS EXAMINATION
OCTOBER 2001 BWR--FORM A

QUESTION: 2

Refer to the drawing of two pressure vessels with relief protection (see figure below).

Vessel A is completely filled with water at 150°F. Vessel B is in a saturated condition containing 1/2 steam (100% quality) and 1/2 water (0% quality) by volume. Both vessels are currently pressurized to 50 psig and are protected by identical relief valves.

If both relief valves open simultaneously, the faster pressure reduction will occur in vessel _____ and if both relief valves close at 40 psig, the greater mass loss will have occurred in vessel _____.

- A. A; A
- B. A; B
- C. B; A
- D. B; B

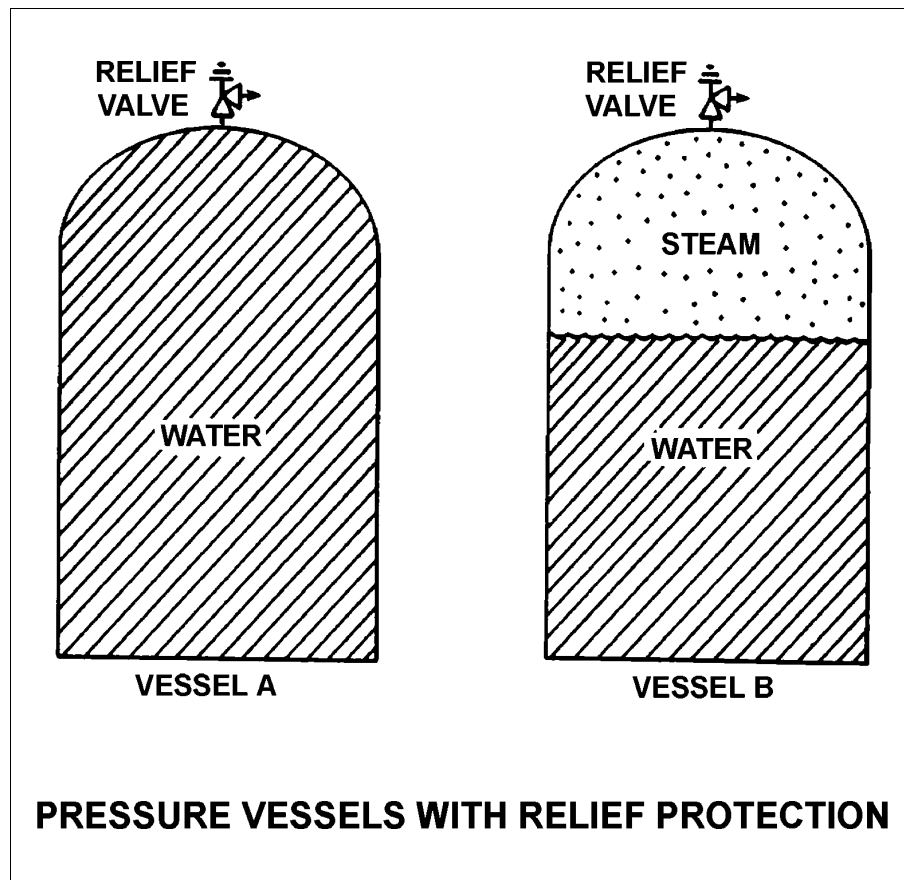

**USNRC GENERIC FUNDAMENTALS EXAMINATION
OCTOBER 2001 BWR--FORM A**

QUESTION: 3

Refer to the drawing of a spring-loaded air-operated valve (see figure below).

Upon a loss of air pressure, this valve will:

- A. go to the fully open position.
- B. remain at the current position.
- C. go to the fully closed position.
- D. go to the midposition.

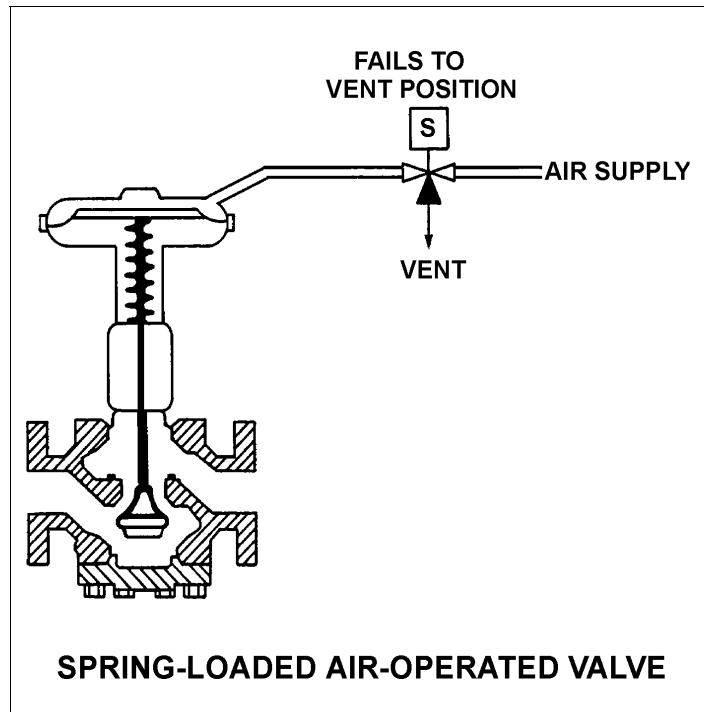

**USNRC GENERIC FUNDAMENTALS EXAMINATION
OCTOBER 2001 BWR--FORM A**

QUESTION: 4

Why must an operator pay particular attention to an auto/manual valve controller when it is placed in the manual mode?

- A. Manual valve control is not as stable as automatic valve control.
- B. Valve position will no longer change in response to changes in system parameters.
- C. The position of the valve can only be determined locally during manual control.
- D. The valve can only be operated locally during manual control.

QUESTION: 5

When comparing a globe valve and a gate valve in the same application, the gate valve has a _____ pressure drop when fully open and is the _____ choice for throttling.

- A. higher; better
- B. lower; better
- C. higher; poorer
- D. lower; poorer

**USNRC GENERIC FUNDAMENTALS EXAMINATION
OCTOBER 2001 BWR--FORM A**

QUESTION: 6

A cooling water system uses a horizontal venturi with a flow detector to provide cooling water flow rate indication. Water enters and leaves the venturi at 70°F, 120 psig and 20 ft/sec. Water velocity at the throat of the venturi is 45 ft/sec. Assume water is incompressible and the venturi experiences no unrecoverable head loss.

What is the approximate pressure of the water at the throat of the venturi?

- A. 109 psig
- B. 98 psig
- C. 86 psig
- D. 71 psig

QUESTION: 7

Density input is normally used in steam flow instruments to convert _____ into _____.

- A. mass flow rate; volumetric flow rate
- B. differential pressure; volumetric flow rate
- C. mass flow rate; differential pressure
- D. volumetric flow rate; mass flow rate

**USNRC GENERIC FUNDAMENTALS EXAMINATION
OCTOBER 2001 BWR--FORM A**

QUESTION: 8

If the orifice in a differential pressure (D/P) flow sensor erodes such that the orifice opening becomes larger, indicated flow rate will _____ due to a _____ D/P across the orifice. (Assume actual flow rate remains the same.)

- A. increase; larger
- B. increase; smaller
- C. decrease; larger
- D. decrease; smaller

**USNRC GENERIC FUNDAMENTALS EXAMINATION
OCTOBER 2001 BWR--FORM A**

QUESTION: 9

Refer to the drawing of a horizontal pipe elbow (top view) in an operating water system (see figure below). Three separate bellows differential pressure flow detectors are connected to taps A, B, C, and D as follows:

<u>DETECTOR</u>	<u>TAPS</u>
AD	A and D
BD	B and D
CD	C and D

Assuming zero head loss in the elbow, how will the detectors be affected if tap D ruptures?

- A. All detectors will fail high.
- B. All detectors will fail low.
- C. Two detectors will fail high and one will fail low.
- D. Two detectors will fail low and one will fail high.

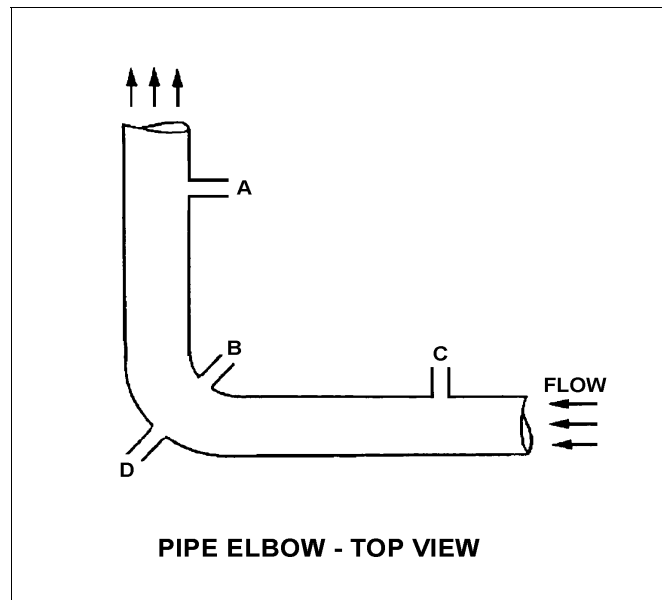

**USNRC GENERIC FUNDAMENTALS EXAMINATION
OCTOBER 2001 BWR--FORM A**

QUESTION: 10

A reactor is currently shut down at 180°F and 100 psig. Reactor vessel (RV) level is being monitored using a normal at-power RV level instrument that was calibrated at normal plant operating conditions.

The RV level instrument indicates _____ than actual RV level because, compared to the calibration conditions, there has been a significant change in the density of the fluid in the _____.

- A. less; reference leg
- B. less; reactor vessel
- C. greater; reference leg
- D. greater; reactor vessel

QUESTION: 11

A bourdon tube system pressure detector is located inside a sealed building and currently indicates 100 psig. A building ambient temperature increase of 100°F will cause a _____ change in indicated system pressure, and a building pressure increase of 40 psig will cause a _____ change in indicated system pressure.

- A. significant; significant
- B. negligible; significant
- C. significant; negligible
- D. negligible; negligible

**USNRC GENERIC FUNDAMENTALS EXAMINATION
OCTOBER 2001 BWR--FORM A**

QUESTION: 12

Unlike a resistance temperature detector, a typical thermocouple:

- A. uses a single type of metal in the sensing element
- B. requires a temperature-controlled reference junction.
- C. can provide temperature input to a valve controller in a cooling water system.
- D. requires an external power supply to provide indication of temperature.

QUESTION: 13

Which one of the following devices is commonly used to provide remote indication of valve position on an analog meter in units of "percent of full open"?

- A. Limit switch
- B. Reed switch
- C. Linear variable differential transformer
- D. Resistance temperature detector

**USNRC GENERIC FUNDAMENTALS EXAMINATION
OCTOBER 2001 BWR--FORM A**

QUESTION: 14

What is the effect on a proportional neutron detector if it is operated at a voltage near the high end of the proportional (true proportional) region on the gas-filled detector characteristic curve?

- A. Detection of any single ionizing event will result in ionizing nearly the entire detector gas volume. The resulting large pulses will prevent the detector from differentiating between radiation types, yielding a less accurate neutron count rate.
- B. A high gamma radiation field will result in multiple small gamma pulses that combine to look like a larger pulse. The combined pulses will be counted as neutron pulses, yielding a less accurate neutron count rate.
- C. Neutron pulses will become so large that gamma pulse discrimination is no longer needed, yielding a more accurate neutron count rate.
- D. The positive space charge effect will increase and prevent collection of both gamma and neutron pulses, yielding a less accurate neutron count rate.

QUESTION: 15

Which one of the following controller types is designed to control the measured parameter at the controller set point?

- A. Integral
- B. Proportional
- C. On-Off
- D. Derivative

**USNRC GENERIC FUNDAMENTALS EXAMINATION
OCTOBER 2001 BWR--FORM A**

QUESTION: 16

Refer to the drawing of a pressure bistable in an alarm circuit (see figure below).

Assume the orientation of the bistable symbol indicates the characteristics of the bistable. The bistable turns on to actuate an alarm at a system pressure of 100 psig. The bistable has a 5 psig dead band, or neutral zone.

If current system pressure is 90 psig, which one of the following describes the alarm response as system pressure is slowly increased to 110 psig?

- A. The alarm is currently actuated and will turn off at 95 psig.
- B. The alarm is currently actuated and will turn off at 105 psig.
- C. The alarm will actuate at 100 psig and will NOT turn off.
- D. The alarm will actuate at 100 psig and will turn off at 105 psig.

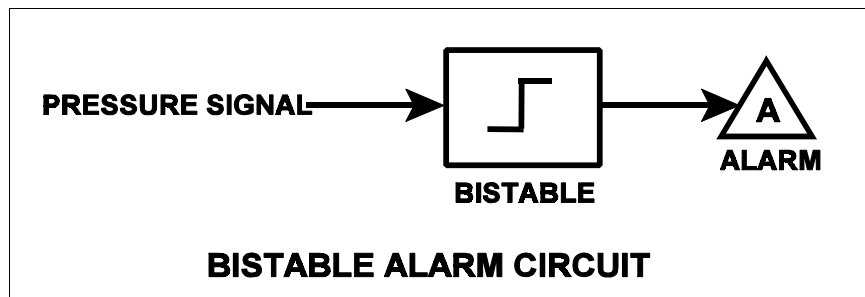

**USNRC GENERIC FUNDAMENTALS EXAMINATION
OCTOBER 2001 BWR--FORM A**

QUESTION: 17

Given the following diesel generator design ratings:

Overspeed trip setpoint:	2000 rpm
Operating speed, no load:	1800 rpm
Operating speed, full load:	1720 rpm

Which one of the following is the speed droop for the diesel generator?

- A. 2.8%
- B. 3.4%
- C. 3.8%
- D. 4.4%

USNRC GENERIC FUNDAMENTALS EXAMINATION
OCTOBER 2001 BWR--FORM A

QUESTION: 18

Refer to the drawing of a centrifugal pump operating curve (see figure below).

Which point represents pump operation at shutoff head?

- A. Point A
- B. Point B
- C. Point C
- D. Point D

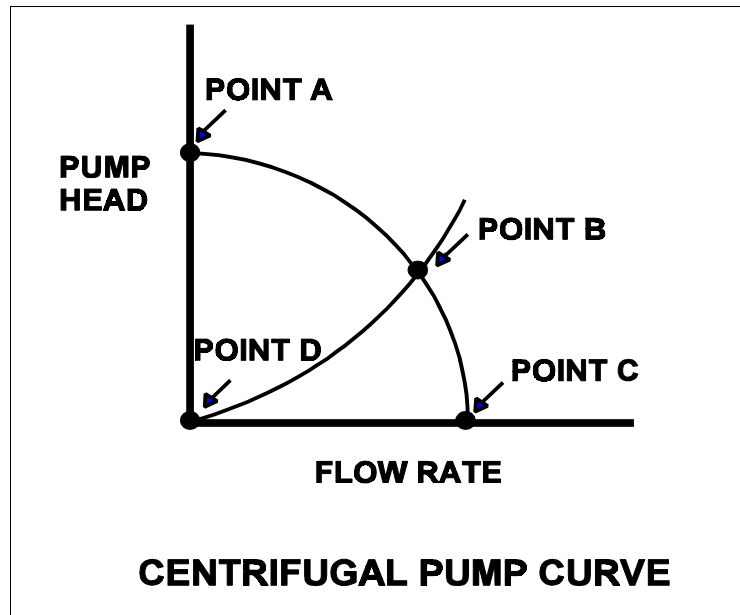

**USNRC GENERIC FUNDAMENTALS EXAMINATION
OCTOBER 2001 BWR--FORM A**

QUESTION: 19

A centrifugal pump is taking suction on an open storage tank that is filled to a level of 40 feet with 10,000 gallons of 60°F water. The pump is located at the base of the tank, takes a suction from the bottom of the tank, and discharges through a fire hose.

Given:

- The pump is currently operating at its design flow rate of 200 gpm and a total developed head of 150 feet.
- The pump requires 4 feet of net positive suction head (NPSH).

How will the centrifugal pump flow rate be affected as the water storage tank level decreases?

- A. Flow rate will remain constant until the pump begins to cavitate at a tank level of about 4 feet.
- B. Flow rate will remain constant until the pump becomes air bound when the tank empties.
- C. Flow rate will gradually decrease until the pump begins to cavitate at a tank level of about 4 feet.
- D. Flow rate will gradually decrease until the pump becomes air bound when the tank empties.

QUESTION: 20

A centrifugal pump in a cooling water system is circulating water at 180°F with a motor current of 200 amps. After several hours, system temperature has changed such that the water density has increased by 3%.

Assuming pump head remains the same, which one of the following is the new pump motor current?

- A. 203 amps
- B. 206 amps
- C. 218 amps
- D. 236 amps

**USNRC GENERIC FUNDAMENTALS EXAMINATION
OCTOBER 2001 BWR--FORM A**

QUESTION: 21

Many large centrifugal pumps are interlocked so that the pump will not start unless its discharge valve is at least 90% closed. This interlock is provided to minimize the:

- A. duration of the pump motor starting current.
- B. required net positive suction head.
- C. loading on the pump thrust bearing.
- D. pump discharge pressure.

QUESTION: 22

Two identical centrifugal pumps (CPs) and two identical positive displacement pumps (PDPs) are able to take suction on a vented water storage tank and provide makeup water flow to a cooling water system. The pumps are capable of being cross-connected to provide multiple configurations. In single pump alignment, each pump will supply 100 gpm at a system pressure of 1200 psig.

Given the following information:

Centrifugal Pumps

Shutoff head:	1500 psig
Maximum design pressure:	2000 psig
Flow rate with no backpressure:	180 gpm

Positive Displacement Pumps

Maximum design pressure:	2000 psig
--------------------------	-----------

Which one of the following pump configurations will supply the highest makeup flow rate to the cooling water system if system pressure is at 1700 psig?

- A. Two CPs in series
- B. Two CPs in parallel
- C. Two PDPs in parallel
- D. One PDP and one CP in series (CP supplying PDP)

**USNRC GENERIC FUNDAMENTALS EXAMINATION
OCTOBER 2001 BWR--FORM A**

QUESTION: 23

A motor-driven centrifugal pump is operating in an open system with its discharge valve throttled to 50%. How will the pump be affected if the discharge valve is fully opened?

- A. Motor current decreases and total developed head decreases.
- B. Available net positive suction head (NPSH) decreases, and pump differential pressure decreases.
- C. Total developed head increases and available NPSH decreases.
- D. The potential for pump cavitation decreases, and pump differential pressure decreases.

QUESTION: 24

A variable-speed positive displacement pump is operating at 100 rpm with a flow rate of 60 gpm in an open system. To decrease pump flow rate to 30 gpm, pump speed must be decreased to approximately:

- A. 25 rpm.
- B. 33 rpm.
- C. 50 rpm.
- D. 71 rpm.

**USNRC GENERIC FUNDAMENTALS EXAMINATION
OCTOBER 2001 BWR--FORM A**

QUESTION: 25

A positive displacement pump should be started with its suction valve _____ and its discharge valve _____.

- A. closed; closed
- B. closed; open
- C. open; closed
- D. open; open

QUESTION: 26

Continuous operation of a motor at rated load with a loss of required cooling to the motor windings will eventually result in:

- A. cavitation of the pumped fluid.
- B. failure of the motor overcurrent protection devices.
- C. breakdown of the motor insulation and electrical grounds.
- D. phase current imbalance in the motor and overspeed trip actuation.

**USNRC GENERIC FUNDAMENTALS EXAMINATION
OCTOBER 2001 BWR--FORM A**

QUESTION: 27

A cooling water system is being returned to service following maintenance on the two identical centrifugal cooling water pumps. The two pumps take suction from a common suction header and discharge to a common discharge header. Each pump is driven by a three phase ac induction motor.

Cooling water pump A was started five minutes ago to initiate flow in the cooling water system. Cooling water pump B is about to be started in parallel alignment with pump A.

When pump B is started, which one of the following would cause the ammeter for pump B to remain off-scale high for several seconds longer than usual before returning to normal running current indication?

- A. The pump packing was removed and not reinstalled.
- B. The pump was initially rotating in the reverse direction.
- C. Two phases of the motor windings were electrically switched.
- D. The coupling between the motor and the pump was removed and not reinstalled.

QUESTION: 28

A difference in electrical potential is measured in:

- A. volts.
- B. amps.
- C. ohms.
- D. volt-amps reactive.

**USNRC GENERIC FUNDAMENTALS EXAMINATION
OCTOBER 2001 BWR--FORM A**

QUESTION: 29

The main generator is paralleled to the grid with VARs currently at zero. If generator field excitation increases, generator VARs will become _____ and generator power factor will become _____.

- A. positive (VARs out); leading
- B. negative (VARs in); leading
- C. positive (VARs out); lagging
- D. negative (VARs in); lagging

QUESTION: 30

A 4160 Vac diesel generator (D/G) is loaded to 2850 kW with a 0.85 power factor. What is the approximate kVAR load on the D/G?

- A. 503 kVAR
- B. 1766 kVAR
- C. 2850 kVAR
- D. 3353 kVAR

**USNRC GENERIC FUNDAMENTALS EXAMINATION
OCTOBER 2001 BWR--FORM A**

QUESTION: 31

Which one of the following describes the process for placing a steam (shell) and water (tube) heat exchanger into service?

- A. Water side is valved in before the steam side to ensure adequate venting.
- B. Water side is valved in before the steam side to minimize thermal shock.
- C. Steam side is valved in before the water side to minimize scale buildup on the heat exchanger tubes.
- D. Steam side is valved in before the water side to ensure that the cooldown rate does not exceed 100°F/hr.

**USNRC GENERIC FUNDAMENTALS EXAMINATION
OCTOBER 2001 BWR--FORM A**

QUESTION: 32

Refer to the drawing of a water cleanup system (see figure below). Valves A, B, and D are fully open and valve C is 20% open.

If valve C is opened to 50%, how will the temperatures at points 3 and 6 be affected?

- | <u>Point 3</u> | <u>Point 6</u> |
|----------------|----------------|
| A. Decrease | Decrease |
| B. Decrease | Increase |
| C. Increase | Decrease |
| D. Increase | Increase |

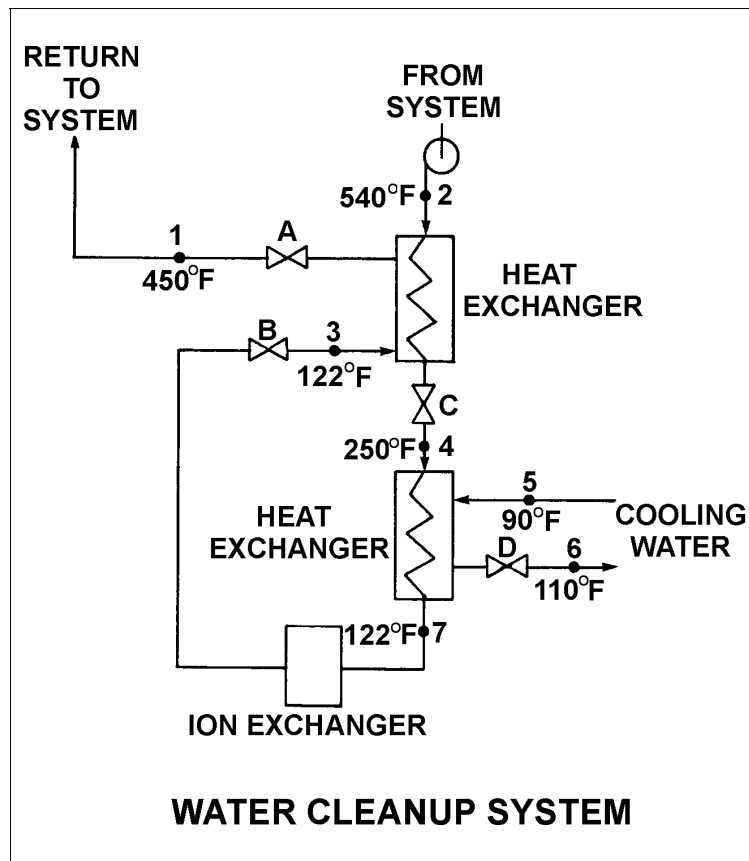

**USNRC GENERIC FUNDAMENTALS EXAMINATION
OCTOBER 2001 BWR--FORM A**

QUESTION: 33

Refer to the drawing of a lube oil heat exchanger (see figure below).

The heat exchanger is operating with the following parameters:

$$\begin{aligned} C_{p\text{-oil}} &= 1.1 \text{ Btu/lbm-}^\circ\text{F} \\ C_{p\text{-water}} &= 1.0 \text{ Btu/lbm-}^\circ\text{F} \\ T_{\text{oil in}} &= 174^\circ\text{F} \\ T_{\text{oil out}} &= 114^\circ\text{F} \\ T_{\text{water in}} &= 85^\circ\text{F} \\ T_{\text{water out}} &= 115^\circ\text{F} \\ \dot{m}_{\text{oil}} &= 4.0 \times 10^4 \text{ lbm/hr} \\ \dot{m}_{\text{water}} &= ? \end{aligned}$$

What is the mass flow rate of the cooling water?

- A. 8.8×10^4 lbm/hr
- B. 7.3×10^4 lbm/hr
- C. 2.2×10^4 lbm/hr
- D. 1.8×10^4 lbm/hr

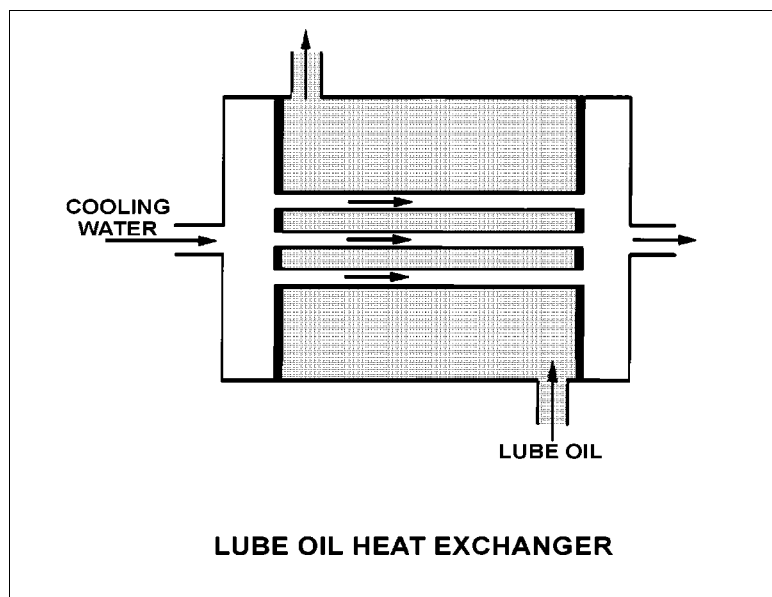

**USNRC GENERIC FUNDAMENTALS EXAMINATION
OCTOBER 2001 BWR--FORM A**

QUESTION: 34

The reactor is shut down at 400°F with all control rods fully inserted. What is the major adverse consequence resulting from rapidly reducing the reactor coolant/moderator temperature to 250°F?

- A. Excessive stress in the ceramic fuel pellets of the reactor core
- B. Excessive stress on the reactor vessel wall
- C. Uncontrolled reactor criticality
- D. Loss of core inlet subcooling

QUESTION: 35

A pressure gauge on a condenser reads 2 psiv. What is the approximate absolute pressure corresponding to this vacuum?

- A. 2 psia
- B. 13 psia
- C. 15 psia
- D. 17 psia

**USNRC GENERIC FUNDAMENTALS EXAMINATION
OCTOBER 2001 BWR--FORM A**

QUESTION: 36

A reactor is shut down at 400 psia during a maintenance outage when all forced decay heat removal is lost. Which one of the following will enhance natural circulation within the reactor vessel?

- A. Increasing reactor vessel pressure to 500 psia
- B. Increasing reactor vessel water level above the steam separators
- C. Decreasing reactor vessel pressure to 300 psia
- D. Decreasing reactor vessel water level to just above the top of the core

QUESTION: 37

High differential pressure in a demineralizer could be caused by all of the following except:

- A. resin exhaustion.
- B. resin overheating.
- C. crud buildup.
- D. high flow rate.

**USNRC GENERIC FUNDAMENTALS EXAMINATION
OCTOBER 2001 BWR--FORM A**

QUESTION: 38

What percentage of ionic impurities is being removed from the water passing through an ion exchanger if the ion exchanger has a decontamination factor of 50?

- A. 98%
- B. 96%
- C. 75%
- D. 50%

QUESTION: 39

The cation resin in a mixed-bed demineralizer releases desirable _____ ions into solution while removing undesirable _____ ions from solution.

- A. negative; negative
- B. negative; positive
- C. positive; negative
- D. positive; positive

**USNRC GENERIC FUNDAMENTALS EXAMINATION
OCTOBER 2001 BWR--FORM A**

QUESTION: 40

Circuit breaker local overcurrent trip flag indicators, when actuated, indicate that:

- A. a breaker trip will occur unless current is reduced.
- B. a breaker overcurrent condition is responsible for a breaker trip.
- C. an overcurrent condition has cleared and the breaker can be closed.
- D. the associated circuit breaker has failed to trip open during an overcurrent condition.

QUESTION: 41

The following remote indications are observed for a 480 Vac load supply breaker. (The breaker is normally open.)

Red indicating light is on.
Green indicating light is off.
Load voltage indicates 0 Vac.
Line voltage indicates 480 Vac.

What is the condition of the breaker?

- A. Open and racked in
- B. Closed and racked in
- C. Open and racked to the "test" position
- D. Closed and racked to the "test" position

**USNRC GENERIC FUNDAMENTALS EXAMINATION
OCTOBER 2001 BWR--FORM A**

QUESTION: 42

A typical 120 Vac manual circuit breaker has tripped due to overload. To close this circuit breaker the handle must be moved from the:

- A. OFF position directly to the ON position; trip latch reset is not required.
- B. midposition directly to the ON position; trip latch reset is not required.
- C. OFF position to the midposition to reset the trip latch, and then to the ON position.
- D. midposition to the OFF position to reset the trip latch, and then to the ON position.

**USNRC GENERIC FUNDAMENTALS EXAMINATION
OCTOBER 2001 BWR--FORM A**

QUESTION: 43

Refer to the drawing of a motor controller circuit for a three-phase ac motor (see figure below).

Select the combination below that completes the following statement:

The two overload (OL) relays protect the motor from overload current on _____ motor phases, and _____ OL relay(s) must actuate to deenergize the main coil.

- A. only two; only one
- B. only two; both
- C. all three; only one
- D. all three; both

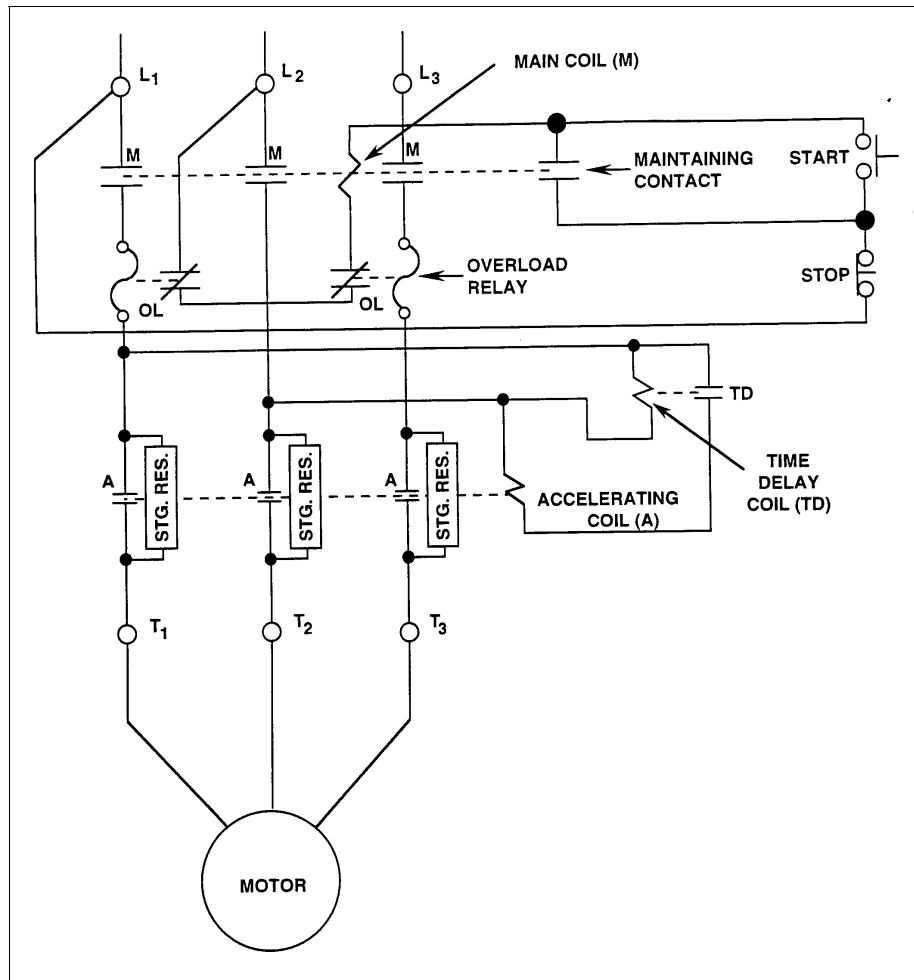

**USNRC GENERIC FUNDAMENTALS EXAMINATION
OCTOBER 2001 BWR--FORM A**

QUESTION: 44

A typical main generator is being paralleled to the grid. Generator voltage is slightly higher than grid voltage and the synchroscope is rotating slowly in the clockwise direction. The generator breaker is closed just as the synchroscope pointer reaches the 3 o'clock position.

Which one of the following will occur after the breaker is closed?

- A. The breaker will remain closed and the generator will supply only MW to the grid.
- B. The breaker will remain closed and the generator will supply both MW and MVAR to the grid.
- C. The breaker will open due to overcurrent.
- D. The breaker will open due to reverse power.

QUESTION: 45

Compared to a prompt neutron, a delayed neutron born from the same fission event is more likely to:

- A. leak out of the core.
- B. be absorbed in a B-10 nucleus.
- C. undergo resonance capture in a Pu-240 nucleus.
- D. cause fission of a U-238 nucleus.

**USNRC GENERIC FUNDAMENTALS EXAMINATION
OCTOBER 2001 BWR--FORM A**

QUESTION: 46

Which one of the following ranges contains the energy level of thermal neutrons in a reactor operating at full power?

- A. less than 0.1 eV
- B. 1 to 10 eV
- C. 100 to 1,000 eV
- D. greater than 1 MeV

QUESTION: 47

Shutdown margin for an operating reactor is the amount of reactivity by which a xenon-free reactor at 68°F would be subcritical if all control rods were:

- A. withdrawn, assuming an average worth rod remains fully inserted.
- B. inserted, assuming an average worth rod remains fully withdrawn.
- C. withdrawn, assuming the highest worth rod remains fully inserted.
- D. inserted, assuming the highest worth rod remains fully withdrawn.

**USNRC GENERIC FUNDAMENTALS EXAMINATION
OCTOBER 2001 BWR--FORM A**

QUESTION: 48

With $K_{\text{eff}} = 0.987$, how much reactivity must be added to make the reactor exactly critical?
(Answer options are rounded to the nearest 0.01% $\Delta K/K$.)

- A. 1.01% $\Delta K/K$
- B. 1.03% $\Delta K/K$
- C. 1.30% $\Delta K/K$
- D. 1.32% $\Delta K/K$

QUESTION: 49

Two reactors are identical in every way except that reactor A is at the end of core life and reactor B is at the beginning of core life. Both reactors are operating at 100% power when a reactor scram occurs at the same time on each reactor. The reactor systems for each reactor respond identically to the scram and no operator action is taken.

Ten minutes after the scram, the higher fission rate will exist in reactor _____ because it has a _____ delayed neutron fraction.

- A. A; larger
- B. B; larger
- C. A; smaller
- D. B; smaller

**USNRC GENERIC FUNDAMENTALS EXAMINATION
OCTOBER 2001 BWR--FORM A**

QUESTION: 50

Refer to the unlabeled reactor response curve shown below for a reactor that was initially stable in the source range. A momentary control rod withdrawal occurred at time = 0 sec.

The response curve shows _____ versus time for a reactor that was initially _____.

- A. reactor period; subcritical
- B. reactor period; critical
- C. reactor fission rate; subcritical
- D. reactor fission rate; critical

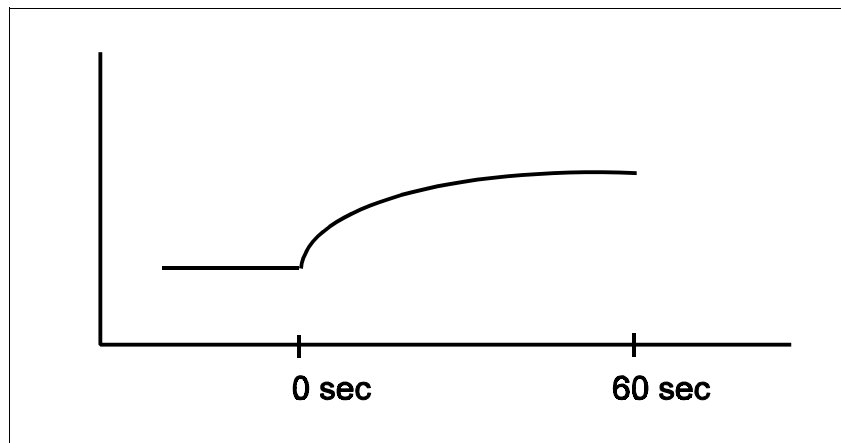

**USNRC GENERIC FUNDAMENTALS EXAMINATION
OCTOBER 2001 BWR--FORM A**

QUESTION: 51

During a reactor startup, the reactor is critical at 3,000 counts per second (cps). A control rod is notched out, resulting in a doubling time of 85 seconds. How much time is required for the reactor to reach 888,000 cps?

- A. 341 seconds
- B. 483 seconds
- C. 697 seconds
- D. 965 seconds

QUESTION: 52

How does control rod withdrawal affect the moderator temperature coefficient (MTC) in an overmoderated reactor core?

- A. The initially positive MTC becomes more positive.
- B. The initially positive MTC becomes less positive.
- C. The initially negative MTC becomes more negative.
- D. The initially negative MTC becomes less negative.

**USNRC GENERIC FUNDAMENTALS EXAMINATION
OCTOBER 2001 BWR--FORM A**

QUESTION: 53

A reactor plant is operating at 70% power. Which one of the following will result in a less negative fuel temperature coefficient? (Consider only the direct effect of the change in each listed parameter.)

- A. Increase in Pu-240 inventory in the core
- B. Increase in moderator temperature
- C. Increase in fuel temperature
- D. Increase in void fraction

QUESTION: 54

The reverse power effect (or reverse reactivity effect) occasionally observed when a shallow control rod is withdrawn one or two notches is due to a relatively:

- A. small local power decrease due to increased local Doppler effects.
- B. small local power decrease due to the shadowing effect of nearby control rods.
- C. large local power increase being offset by a void-related power decrease.
- D. large local power increase being offset by a moderator temperature-related power decrease.

**USNRC GENERIC FUNDAMENTALS EXAMINATION
OCTOBER 2001 BWR--FORM A**

QUESTION: 55

Which one of the following events will cause control rod worth to become less negative?

- A. Fuel temperature decreases as the fuel pellets come into contact with the fuel clad.
- B. The moderator is heated from 170°F to 215°F during a startup.
- C. Reactor power is increased from 40% to 60% by withdrawing control rods.
- D. Early in core life, the concentration of burnable poison decreases.

QUESTION: 56

Neutron flux shaping within a reactor core is designed to:

- A. ensure that local core thermal power limits are not exceeded.
- B. minimize the reverse power effect during control rod motion.
- C. prevent the effects of rod shadowing during control rod motion.
- D. generate more power in the top portion of the core early in core life.

**USNRC GENERIC FUNDAMENTALS EXAMINATION
OCTOBER 2001 BWR--FORM A**

QUESTION: 57

A control rod located at notch position _____ in the core would be considered a _____ control rod.

- A. 36; deep
- B. 36; intermediate
- C. 12; intermediate
- D. 12; deep

QUESTION: 58

A reactor plant is being returned to operation following a refueling outage. Fuel preconditioning requires reactor power to be increased from 10% to full power gradually over a one week period.

During this slow power increase, most of the positive reactivity added by the operator is required to overcome the negative reactivity from:

- A. fuel burnup.
- B. xenon buildup.
- C. fuel temperature increase.
- D. moderator temperature increase.

**USNRC GENERIC FUNDAMENTALS EXAMINATION
OCTOBER 2001 BWR--FORM A**

QUESTION: 59

A reactor is initially operating at equilibrium 100% power. An operator inserts control rods intermittently over a period of 30 minutes. At the end of this time period, reactor power is 70%.

Given:

$$\begin{aligned} \text{Total reactivity added by operator} &= -3.3 \times 10^{-3} \Delta K/K \\ \text{Total power coefficient} &= -1.1 \times 10^{-4} \Delta K/K/\% \text{ power} \end{aligned}$$

Assuming no additional operator actions are taken, what will reactor power be after an additional 60 minutes?

- A. 70% and stable
- B. Less than 70% and increasing
- C. Less than 70% and decreasing
- D. Less than 70% and stable

QUESTION: 60

Compared to other poisons in the core, the two characteristics that cause Xe-135 to be a major reactor poison are its relatively _____ absorption cross section and its relatively _____ variation in concentration for large reactor power changes.

- A. small; large
- B. small; small
- C. large; small
- D. large; large

**USNRC GENERIC FUNDAMENTALS EXAMINATION
OCTOBER 2001 BWR--FORM A**

QUESTION: 61

Which one of the following describes the change in core xenon-135 concentration immediately following a power increase from equilibrium conditions?

- A. Initially decrease due to the decreased rate of xenon-135 production from fission.
- B. Initially decrease due to the increased rate of thermal neutron absorption by xenon-135.
- C. Initially increase due to the increased rate of xenon-135 production from fission.
- D. Initially increase due to the decreased rate of thermal neutron absorption by xenon-135.

QUESTION: 62

Which one of the following reactor startup conditions requires the least amount of control rod withdrawal to attain reactor criticality during peak core xenon-135 conditions after a reactor scram from equilibrium core xenon-135 conditions? (Assume equilibrium core xenon-135 reactivities at 20% power and 100% power do not change over core life.)

- A. Scram from 20% power at beginning of core life (BOL)
- B. Scram from 20% power at end of core life (EOL)
- C. Scram from 100% power at BOL
- D. Scram from 100% power at EOL

**USNRC GENERIC FUNDAMENTALS EXAMINATION
OCTOBER 2001 BWR--FORM A**

QUESTION: 63

A reactor has been operating at full power for 10 weeks when a scram occurs. The reactor is made critical 24 hours later, and power level is maintained low in the intermediate range.

To maintain a constant power level for the next several hours, control rods must be:

- A. inserted, because xenon burnout will cause increased neutron flux peaking near the periphery of the core.
- B. maintained at the present height as xenon establishes its equilibrium value for this power level.
- C. inserted, because xenon will approximately follow its normal decay curve.
- D. withdrawn, because xenon concentration is increasing toward equilibrium.

**USNRC GENERIC FUNDAMENTALS EXAMINATION
OCTOBER 2001 BWR--FORM A**

QUESTION: 64

Refer to the curve of K_{eff} versus core age for an operating reactor (see figure below).

The reactor has been operating at 100% power for several weeks and is currently operating between points 2 and 3 on the curve.

Assuming reactor recirculation flow rate remains the same, what general control rod operation will be necessary to maintain the reactor operating at 100% power until point 3 is reached?

- A. Withdrawal for the entire period.
- B. Withdrawal at first, then insertion.
- C. Insertion for the entire period.
- D. Insertion at first, then withdrawal.

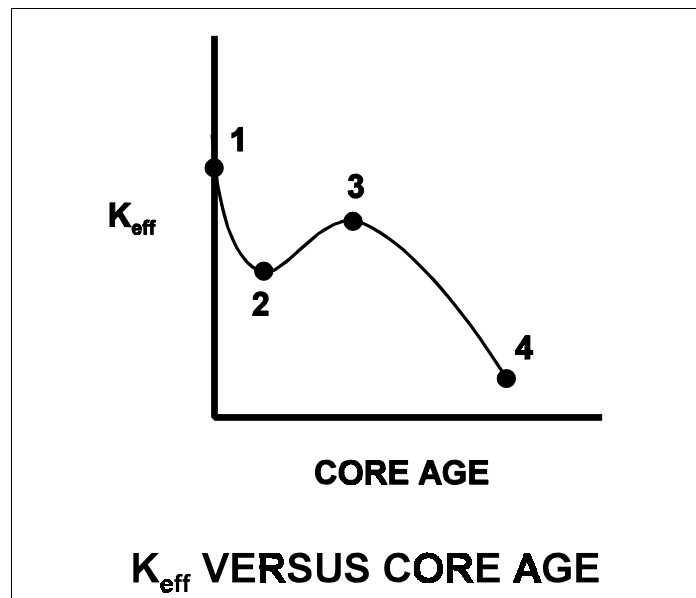

**USNRC GENERIC FUNDAMENTALS EXAMINATION
OCTOBER 2001 BWR--FORM A**

QUESTION: 65

After taking critical data during a reactor startup, the operator establishes a stable 38-second reactor period to increase power to the point of adding heat (POAH). Which one of the following is the approximate negative reactivity required to stop the power increase at the POAH? (Assume that $\beta = 0.00579$.)

- A. 0.01% $\Delta K/K$
- B. 0.12% $\Delta K/K$
- C. 0.16% $\Delta K/K$
- D. 0.21% $\Delta K/K$

QUESTION: 66

A reactor is critical and a heat-up is in progress with reactor temperature currently at 140°F. If the point of adding heat was 1% reactor power, and reactor power is held constant at 3% during the heat-up, which one of the following describes the heat-up rate (HUR) from 140°F to 200°F?

- A. HUR will initially decrease and then increase.
- B. HUR will slowly decrease during the entire period.
- C. HUR will slowly increase during the entire period.
- D. HUR will remain the same during the entire period.

**USNRC GENERIC FUNDAMENTALS EXAMINATION
OCTOBER 2001 BWR--FORM A**

QUESTION: 67

Neglecting the effects of changes in core Xe-135, which one of the following power changes requires the greatest amount of positive reactivity addition?

- A. 3% power to 5% power
- B. 5% power to 15% power
- C. 15% power to 30% power
- D. 30% power to 60% power

QUESTION: 68

Reactor power is increased from 70% to 90% by changing recirculation flow. Which one of the following describes the effect on the plant?

- A. Core void fraction increases.
- B. Feedwater temperature decreases.
- C. Reactor vessel outlet steam pressure increases.
- D. Condensate depression in the main condenser hotwell increases.

**USNRC GENERIC FUNDAMENTALS EXAMINATION
OCTOBER 2001 BWR--FORM A**

QUESTION: 69

A reactor has been operating at full power for several months. Following a normal reactor shutdown, steam production will continue for some period of time, with the rate of steam production dependent upon the:

- A. rate of reactor power decrease from full power to the point of adding heat.
- B. pressure being maintained in the reactor pressure vessel (RPV).
- C. previous power history of the plant and the time elapsed since shutdown.
- D. recirculation flow rate and the water level being maintained in the RPV.

QUESTION: 70

A plant is operating normally at 50% power when a steam line break occurs that releases 5% of rated steam flow. Assume no operator or protective actions occur, automatic pressure control returns reactor pressure to its value prior to the break, and feedwater injection temperature remains the same.

How will reactor power respond to the steam line break?

- A. Decrease and stabilize at a lower power level
- B. Increase and stabilize at a higher power level
- C. Decrease initially, then increase and stabilize at the previous power level
- D. Increase initially, then decrease and stabilize at the previous power level

**USNRC GENERIC FUNDAMENTALS EXAMINATION
OCTOBER 2001 BWR--FORM A**

QUESTION: 71

Reactors A and B are identical and have been operated at 100% power for six months when a reactor scram occurs simultaneously on both reactors. All reactor A control rods fully insert. One reactor B control rod sticks fully withdrawn.

After five minutes, when compared to reactor B, the core fission rate in reactor A will be _____, and the reactor period in reactor A will be _____.

- A. lower; the same
- B. lower; shorter
- C. the same; the same
- D. the same; shorter

QUESTION: 72

A reactor is operating at 100% power when one recirculation pump trips. Reactor power decreases and stabilizes at a lower power level. Which one of the following reactivity coefficients caused the initial decrease in reactor power?

- A. Void
- B. Pressure
- C. Moderator temperature
- D. Fuel temperature (Doppler)

**USNRC GENERIC FUNDAMENTALS EXAMINATION
OCTOBER 2001 BWR--FORM A**

QUESTION: 73

Refer to the drawing of four identical tank differential pressure level detectors (see figure below).

The tanks are identical and are presently at 2 psig overpressure and the same constant water level and a temperature of 60°F. They are surrounded by atmospheric pressure. All level detectors have been calibrated and are producing the same level indication. A leak in the top of each tank causes a complete loss of overpressure in both tanks.

Which level detector(s) will produce the lowest level indication?

- A. 1
- B. 2
- C. 1 and 4
- D. 2 and 3

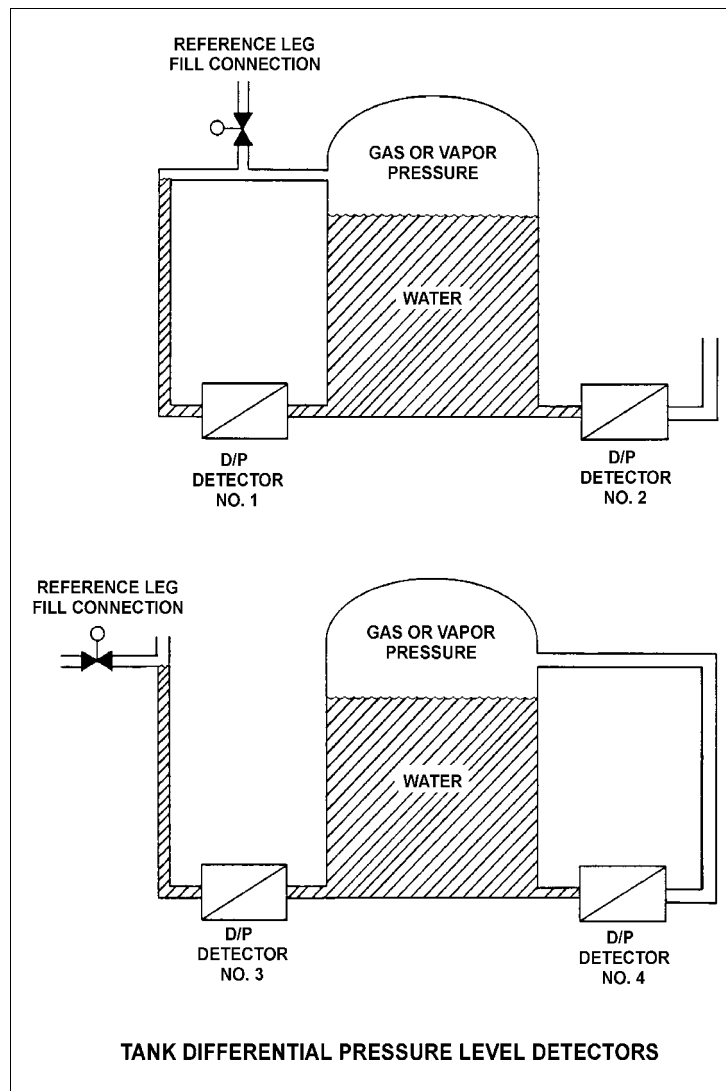

**USNRC GENERIC FUNDAMENTALS EXAMINATION
OCTOBER 2001 BWR--FORM A**

QUESTION: 74

An ideal main turbine generator (MTG) is producing 1000 MW of electrical power while being supplied with 100% quality steam at 920 psig. Steam supply pressure is then gradually increased to 980 psig at the same quality. Assume turbine control valve position and condenser vacuum remain the same.

Which one of the following describes why the MTG output increases as steam pressure increases?

- A. Each lbm of steam entering the turbine has a higher specific heat.
- B. Each lbm of steam entering the turbine has a higher specific enthalpy.
- C. Each lbm of steam passing through the turbine expands to fill a greater volume.
- D. Each lbm of steam passing through the turbine performs increased work in the turbine.

QUESTION: 75

A reactor plant is shutdown at normal operating temperatures and pressures. Reactor coolant temperature is being controlled by dumping main steam (100% quality) to the main condenser.

Given the following:

- Main steam pressure: 1000 psia
- Main condenser vacuum: 28"Hg

Which one of the following is the approximate temperature of the steam as it enters the main condenser?

- A. 102°F
- B. 212°F
- C. 295°F
- D. 358°F

**USNRC GENERIC FUNDAMENTALS EXAMINATION
OCTOBER 2001 BWR--FORM A**

QUESTION: 76

Condensate is collecting in a main condenser hotwell at 90°F with a condenser pressure of 28 inches Hg vacuum. Which one of the following will improve steam cycle efficiency?

- A. Main condenser cooling water flow rate decreases by 5% with no change in condenser vacuum.
- B. Main condenser cooling water inlet temperature decreases by 10°F with no change in condenser vacuum.
- C. Main condenser vacuum decreases to 27 inches Hg due to buildup of noncondensable gases.
- D. Steam flow through the turbine decreases by 10% with no change in condenser vacuum.

QUESTION: 77

The steam inlet nozzles used in steam jet air ejectors convert the _____ of the steam into _____.

- A. kinetic energy; pressure
- B. enthalpy; kinetic energy
- C. kinetic energy; velocity
- D. enthalpy; pressure

**USNRC GENERIC FUNDAMENTALS EXAMINATION
OCTOBER 2001 BWR--FORM A**

QUESTION: 78

A reactor plant was initially operating normally at 90% power when heating steam (extracted from the main turbine) was automatically isolated to several feedwater heaters. Reactor power was returned to 90% and the plant was stabilized.

Compared to the initial main generator MW load, the current main generator MW load is:

- A. lower, because the steam cycle is less efficient.
- B. lower, because less steam is being extracted from the main turbine.
- C. higher, because the steam cycle is less efficient.
- D. higher, because less steam is being extracted from the main turbine.

QUESTION: 79

An ac motor-driven centrifugal pump is operating at rated flow and pressure in a cooling water system. A break occurs in the pump discharge piping resulting in a loss of pump backpressure.

As a result of the break, the pump will operate at a _____ flow rate and the pump motor will draw _____ electrical power.

- A. higher; more
- B. higher; less
- C. lower; more
- D. lower; less

**USNRC GENERIC FUNDAMENTALS EXAMINATION
OCTOBER 2001 BWR--FORM A**

QUESTION: 80

Refer to the drawing of four centrifugal pump operating curves (see figure below).

A centrifugal pump is operating in a closed water system and discharging through a heat exchanger. A second heat exchanger, in parallel with the first, is then placed in service.

Which set of curves illustrates the initial and final operating conditions?

- A. 1.
- B. 2.
- C. 3.
- D. 4.

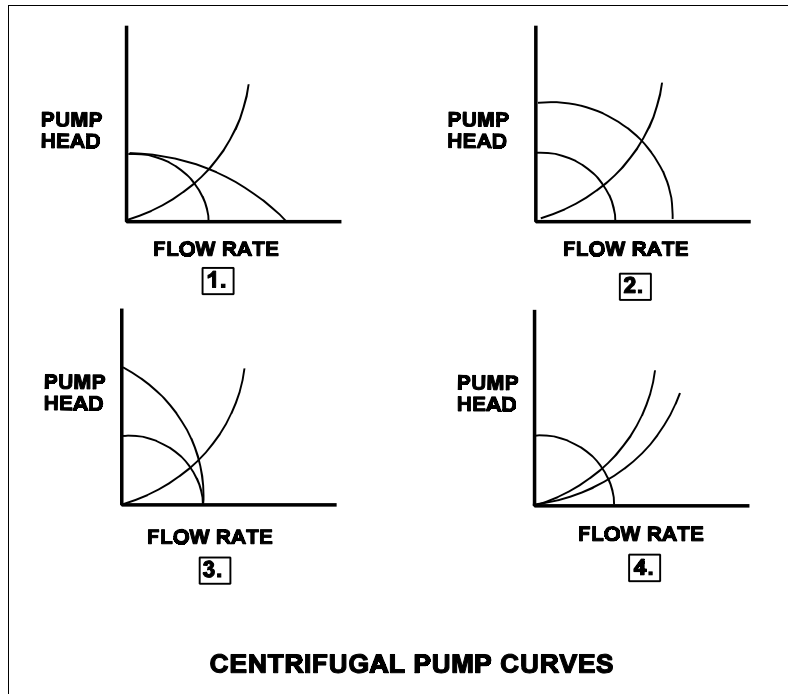

**USNRC GENERIC FUNDAMENTALS EXAMINATION
OCTOBER 2001 BWR--FORM A**

QUESTION: 81

A plant is operating at full power when a 200 gpm reactor coolant leak occurs, which results in a reactor scram and initiation of emergency coolant injection. Reactor vessel pressure stabilizes at 900 psia and all injection pumps are operating with all pump miniflow paths isolated. The shutoff heads for the pumps are as follows:

High pressure coolant injection (HPCI) pumps: 800 psia
Low pressure coolant injection (LPCI) pumps: 200 psia

Which pumps must be stopped quickly and why?

- A. Only the LPCI pumps to avoid pump overheating caused by low flow
- B. All LPCI and HPCI pumps to avoid pump overheating caused by low flow
- C. Only the HPCI pumps to avoid motor overheating caused by high flow
- D. All LPCI and HPCI pumps to avoid motor overheating caused by high flow

QUESTION: 82

Which one of the following is responsible for the majority of the heat transferred from the reactor vessel to the main turbine?

- A. Radiolysis
- B. Radiation
- C. Conduction
- D. Convection

**USNRC GENERIC FUNDAMENTALS EXAMINATION
OCTOBER 2001 BWR--FORM A**

QUESTION: 83

Which one of the following pairs of fluids undergoing heat transfer in typical cross-flow design heat exchangers will yield the greatest heat exchanger overall heat transfer coefficient?

- A. Oil to water in a lube oil cooler
- B. Air to water in an air compressor after-cooler
- C. Steam to water in a turbine exhaust steam condenser
- D. Water to water in a cooling water heat exchanger

QUESTION: 84

Which one of the following expressions describes core thermal power?

- A. $\dot{Q}_{\text{core}} = \dot{Q}_{\text{Feedwater}} - \dot{Q}_{\text{Steam}} - \dot{Q}_{\text{CRD}} - \dot{Q}_{\text{Recirc}} + \dot{Q}_{\text{Ambient}} + \dot{Q}_{\text{RWCU}}$
- B. $\dot{Q}_{\text{core}} = \dot{Q}_{\text{Steam}} - \dot{Q}_{\text{Feedwater}} + \dot{Q}_{\text{CRD}} + \dot{Q}_{\text{Recirc}} - \dot{Q}_{\text{Ambient}} - \dot{Q}_{\text{RWCU}}$
- C. $\dot{Q}_{\text{core}} = \dot{Q}_{\text{Steam}} - \dot{Q}_{\text{Feedwater}} - \dot{Q}_{\text{CRD}} - \dot{Q}_{\text{Recirc}} + \dot{Q}_{\text{Ambient}} + \dot{Q}_{\text{RWCU}}$
- D. $\dot{Q}_{\text{core}} = \dot{Q}_{\text{Steam}} - \dot{Q}_{\text{Feedwater}} - \dot{Q}_{\text{CRD}} - \dot{Q}_{\text{Recirc}} - \dot{Q}_{\text{Ambient}} - \dot{Q}_{\text{RWCU}}$

**USNRC GENERIC FUNDAMENTALS EXAMINATION
OCTOBER 2001 BWR--FORM A**

QUESTION: 85

If ΔT is the temperature difference between the fuel rod clad and the coolant, which one of the following describes the heat transfer from a fuel rod at the departure from nucleate boiling?

- A. Steam bubbles begin to form on the fuel rod clad, causing a rapid decrease in the heat flux from the fuel rod for a given ΔT .
- B. Steam bubbles completely blanket the fuel rod clad, causing a rapid increase in the heat flux from the fuel rod for a given ΔT .
- C. Steam bubbles begin to blanket the fuel rod clad, causing a rapid increase in the ΔT for a given heat flux.
- D. Steam bubbles completely blanket the fuel rod clad, causing a rapid decrease in the ΔT for a given heat flux.

QUESTION: 86

Nucleate boiling occurring at the surface of a fuel rod:

- A. increases the convective heat transfer from the fuel rod to the coolant.
- B. decreases the convective heat transfer from the fuel rod to the coolant.
- C. has no effect on convective heat transfer because it is boiling heat transfer.
- D. causes damage to the fuel rod because it disrupts the laminar flow of coolant next to the fuel rod.

**USNRC GENERIC FUNDAMENTALS EXAMINATION
OCTOBER 2001 BWR--FORM A**

QUESTION: 87

Core inlet subcooling is defined as the difference between the temperature of the fluid _____ and the saturation temperature of the fluid in the core inlet plenum.

- A. in the core inlet plenum
- B. at the feedwater pump discharge
- C. in the downcomer area
- D. in the lower fuel channel area

QUESTION: 88

Forced circulation through a reactor core is required at all times during power operation to prevent:

- A. the core from becoming prompt critical due to high fuel and coolant temperatures.
- B. exceeding reactor vessel and core design steaming rates.
- C. high fuel clad surface temperatures that would result in a crack or leak in the clad.
- D. jet pump cavitation which would reduce the power generated by the core.

**USNRC GENERIC FUNDAMENTALS EXAMINATION
OCTOBER 2001 BWR--FORM A**

QUESTION: 89

Two reactors have the same rated power level and are currently operating at 50% power with the same power distribution in each core. The reactors are identical except that one reactor has core orifices and the other core does not. Each reactor has the same core mass flow rate.

The orificed core will have the _____ critical power and the _____ core differential pressure.

- A. higher; higher
- B. higher; lower
- C. lower; higher
- D. lower; lower

QUESTION: 90

A reactor is operating at equilibrium 100% power. Assuming reactor coolant flow rate into the core region does not change, how will core bypass flow rate be affected during a reactor power decrease to 80%?

- A. Increase because greater two-phase flow resistance exists in the core at 80% power.
- B. Decrease because less two-phase flow resistance exists in the core at 80% power.
- C. Remain the same because core bypass flow rate is dependent only on reactor core flow rate.
- D. Remain the same because core bypass flow rate is unaffected by changes in reactor power.

**USNRC GENERIC FUNDAMENTALS EXAMINATION
OCTOBER 2001 BWR--FORM A**

QUESTION: 91

Reactor coolant flow that bypasses the core is necessary to:

- A. provide a source of water to the incore thermocouples to ensure they measure a representative coolant temperature.
- B. act as a neutron reflector to minimize fast neutron leakage.
- C. ensure that recirculation pump flow rate is adequate to prevent pump overheating.
- D. provide cooling to prevent excessive boiling in the bypass region.

QUESTION: 92

A reactor is operating at steady state 100% reactor power near the beginning of a fuel cycle with core power distribution peaked radially at the center of the core and axially in the bottom of the core. Control rods are used to maintain a constant reactor power over the next three months.

Neglecting any change in reactor poisons, during the next three months the maximum radial peaking factor will _____ and the maximum axial peaking factor will _____.

- A. increase; decrease
- B. increase; increase
- C. decrease; decrease
- D. decrease; increase

**USNRC GENERIC FUNDAMENTALS EXAMINATION
OCTOBER 2001 BWR--FORM A**

QUESTION: 93

The axial peaking factor for a node of a fuel bundle is defined as:

- A. $\frac{\text{core average bundle power}}{\text{peak nodal power}}$
- B. $\frac{\text{peak nodal power}}{\text{core average bundle power}}$
- C. $\frac{\text{bundle average nodal power}}{\text{nodal power}}$
- D. $\frac{\text{nodal power}}{\text{bundle average nodal power}}$

QUESTION: 94

A BWR core consists of 30,000 fuel rods; each fuel rod has an active length of 12 feet. The core is producing 1,800 MW of thermal energy. If the total peaking factor for a node is 2.0, what is the maximum local linear power density being produced in the node?

- A. 4.0 kW/ft
- B. 6.0 kW/ft
- C. 8.0 kW/ft
- D. 10.0 kW/ft

**USNRC GENERIC FUNDAMENTALS EXAMINATION
OCTOBER 2001 BWR--FORM A**

QUESTION: 95

Which one of the following limits takes into consideration fuel-pellet swell effects?

- A. Average gain adjustment factor
- B. Maximum linear heat generation rate
- C. Rated thermal power
- D. Minimum critical power ratio

QUESTION: 96

The amount of heat stored in the fuel, resulting from the operating kW/foot existing in the fuel prior to a scram, is measured by the:

- A. average planar linear heat generation rate (APLHGR).
- B. linear heat generation rate (LHGR) multiplied by the total peaking factor.
- C. core fraction of limiting power density.
- D. APLHGR-to-MAPLHGR ratio.

**USNRC GENERIC FUNDAMENTALS EXAMINATION
OCTOBER 2001 BWR--FORM A**

QUESTION: 97

The primary purpose of the gap between a fuel pellet and the surrounding cladding is to:

- A. allow insertion of fuel pellets into the fuel rods.
- B. provide a collection volume for fission product gases.
- C. maintain the design fuel thermal conductivity throughout the fuel cycle.
- D. accommodate different expansion rates of the fuel pellets and cladding.

QUESTION: 98

Studies of nuclear fuel rod damage revealed that two essential criteria for pellet-clad interaction fuel damage are cladding stress and a chemical embrittling fission product interaction between two chemical agents and the zircalloy cladding.

What are the two (2) chemical agents?

- A. Iodine and cadmium
- B. Cadmium and bromine
- C. Bromine and ruthenium
- D. Ruthenium and iodine

**USNRC GENERIC FUNDAMENTALS EXAMINATION
OCTOBER 2001 BWR--FORM A**

QUESTION: 99

Which one of the following comparisons will result in a higher probability of brittle fracture of the reactor vessel?

- A. A high reactor gamma flux rather than a high neutron flux
- B. A high reactor vessel material strength rather than a high material ductility
- C. A high reactor coolant oxygen content rather than a low oxygen content
- D. A rapid 100°F reactor cooldown at a high temperature rather than a low temperature

QUESTION: 100

A reactor is shut down for refueling following 18 months of operation at an average power level of 85%. During the shutdown, a reactor vessel metal specimen is removed from the reactor vessel for testing. The testing determines that the nil-ductility transition (NDT) temperature of the specimen has increased from 42°F to 44°F since the last refueling.

Which one of the following conclusions is warranted?

- A. The test results are credible and the reactor vessel is more susceptible to brittle fracture now than after the last refueling.
- B. The test results are credible and the reactor vessel is less susceptible to brittle fracture now than after the last refueling.
- C. The test results are questionable because the vessel NDT temperature would not increase during the described 18-month period of operation.
- D. The test results are questionable because the vessel NDT temperature would increase by at least 10°F during the described 18-month period of operation.

*** FINAL ANSWER KEY ***

OCTOBER 2001 NRC GENERIC FUNDAMENTALS EXAMINATION
BOILING WATER REACTOR - ANSWER KEY

FORM		ANS	FORM		ANS	FORM		ANS	FORM		ANS
A	B		A	B		A	B		A	B	
1	29	D	26	54	C	51	79	C	76	4	A
2	30	B	27	55	B	52	80	A/B	77	5	B
3	31	C	28	56	A	53	81	C	78	6	A
4	32	B	29	57	C	54	82	C	79	7	A
5	33	D	30	58	B	55	83	C	80	8	D
6	34	A	31	59	B	56	84	A	81	9	B
7	35	D	32	60	D	57	85	D	82	10	D
8	36	D	33	61	A	58	86	B	83	11	C
9	37	B	34	62	B	59	87	C	84	12	C
10	38	D	35	63	B	60	88	D	85	13	C
11	39	B	36	64	B	61	89	B	86	14	A
12	40	B	37	65	A	62	90	A	87	15	A
13	41	C	38	66	A	63	91	C	88	16	C
14	42	B	39	67	D	64	92	C	89	17	A
15	43	A	40	68	B	65	93	B	90	18	B
16	44	C	41	69	D	66	94	B	91	19	D
17	45	D	42	70	D	67	95	D	92	20	C
18	46	A	43	71	A/C	68	96	C	93	21	D
19	47	D	44	72	C	69	97	C	94	22	D
20	48	B	45	73	B	70	98	C	95	23	B
21	49	A	46	74	A	71	99	A	96	24	A
22	50	C	47	75	D	72	100	A	97	25	D
23	51	B	48	76	D	73	1	D	98	26	A
24	52	C	49	77	B	74	2	D	99	27	B
25	53	D	50	78	C	75	3	C	100	28	A