

**UNITED STATES NUCLEAR REGULATORY COMMISSION  
BOILING WATER REACTOR GENERIC FUNDAMENTALS EXAMINATION  
JUNE 2007--FORM A**

**Please Print**

Name: \_\_\_\_\_

Docket No.: \_\_\_\_\_

Facility: \_\_\_\_\_

Start Time: \_\_\_\_\_ Stop Time: \_\_\_\_\_

**INSTRUCTIONS TO APPLICANT**

Answer all the test items using the answer sheet provided, ensuring a single answer is marked for each test item. Each test item has equal point value. A score of at least 80% is required to pass this portion of the NRC operator licensing written examination. All examination papers will be collected 3.0 hours after the examination starts. This examination applies to a typical boiling water reactor (BWR) nuclear power plant.

SECTION	QUESTIONS	% OF TOTAL	SCORE
COMPONENTS	1 - 22		
REACTOR THEORY	23 - 36		
THERMODYNAMICS	37 - 50		
TOTALS	50		

All work performed on this examination is my own. I have neither given nor received aid.

\_\_\_\_\_  
Applicant's Signature

**RULES AND GUIDELINES FOR THE NRC  
GENERIC FUNDAMENTALS EXAMINATION**

During the administration of this examination the following rules apply:

**NOTE:** The generic term "control rod" refers to the length of neutron absorber material that can be positioned by the operator to change core reactivity.

1. Print your name in the blank provided on the cover sheet of the examination.
2. Fill in your individual docket number.
3. Fill in the name of your facility.
4. Fill in your start and stop times at the appropriate time.
5. Two aids are provided for your use during the examination:
  - (1) An equations and conversions sheet contained within the examination copy, and
  - (2) Steam tables and Mollier Diagram provided by your proctor.
6. Place your answers on the answer sheet provided. Credit will only be given for answers properly marked on this sheet. Follow the instructions for filling out the answer sheet.
7. Scrap paper will be provided for calculations.
8. Cheating on the examination will result in the automatic forfeiture of this examination. Cheating could also result in severe penalties.
9. Restroom trips are limited. Only **ONE** examinee may leave the room at a time. In order to avoid the appearance or possibility of cheating, avoid all contact with anyone outside of the examination room.
10. After you have completed the examination, sign the statement on the cover sheet indicating that the work is your own and you have neither given nor received any assistance in completing the examination. Either pencil or pen may be used.
11. Turn in your examination materials, answer sheet on top, followed by the examination copy and the examination aids - steam table booklets, handouts, and scrap paper used during the examination.
12. After turning in your examination materials, leave the examination area, as defined by the proctor. If after leaving you are found in the examination area while the examination is in progress, your examination may be forfeited.

**GENERIC FUNDAMENTALS EXAMINATION**  
**EQUATIONS AND CONVERSIONS HANDOUT SHEET**

**EQUATIONS**

---

$$\dot{Q} = \dot{m}c_p\Delta T$$

$$\dot{Q} = \dot{m}\Delta h$$

$$\dot{Q} = UA\Delta T$$

$$\dot{Q} \propto \dot{m}_{\text{Nat Circ}}^3$$

$$\Delta T \propto \dot{m}_{\text{Nat Circ}}^2$$

$$K_{\text{eff}} = 1/(1 - \rho)$$

$$\rho = (K_{\text{eff}} - 1)/K_{\text{eff}}$$

$$\text{SUR} = 26.06/\tau$$

$$\tau = \frac{\bar{\beta} - \rho}{\lambda_{\text{eff}} \rho}$$

$$\rho = \frac{\ell^*}{\tau} + \frac{\bar{\beta}}{1 + \lambda_{\text{eff}}\tau}$$

$$\ell^* = 1 \times 10^{-4} \text{ sec}$$

$$\lambda_{\text{eff}} = 0.1 \text{ sec}^{-1} \text{ (for small positive } \rho)$$

$$\text{DRW} \propto \phi_{\text{tip}}^2 / \phi_{\text{avg}}^2$$

$$P = P_o 10^{\text{SUR}(t)}$$

$$P = P_o e^{(t/\tau)}$$

$$A = A_o e^{-\lambda t}$$

$$\text{CR}_{\text{S/D}} = S/(1 - K_{\text{eff}})$$

$$\text{CR}_1(1 - K_{\text{eff}1}) = \text{CR}_2(1 - K_{\text{eff}2})$$

$$1/M = \text{CR}_1/\text{CR}_x$$

$$A = \pi r^2$$

$$F = PA$$

$$\dot{m} = \rho A \bar{v}$$

$$\dot{W}_{\text{Pump}} = \dot{m}\Delta P v$$

$$E = IR$$

$$\text{Thermal Efficiency} = \text{Net Work Out}/\text{Energy In}$$

$$\frac{g(z_2 - z_1)}{g_c} + \frac{(\bar{v}_2^2 - \bar{v}_1^2)}{2g_c} + v(P_2 - P_1) + (u_2 - u_1) + (q - w) = 0$$

$$g_c = 32.2 \text{ lbf-ft/lbf-sec}^2$$

**CONVERSIONS**

---

$$1 \text{ Mw} = 3.41 \times 10^6 \text{ Btu/hr}$$

$$1 \text{ hp} = 2.54 \times 10^3 \text{ Btu/hr}$$

$$1 \text{ Btu} = 778 \text{ ft-lbf}$$

$$^\circ\text{C} = (5/9)(^\circ\text{F} - 32)$$

$$^\circ\text{F} = (9/5)(^\circ\text{C}) + 32$$

$$1 \text{ Curie} = 3.7 \times 10^{10} \text{ dps}$$

$$1 \text{ kg} = 2.21 \text{ lbf}$$

$$1 \text{ gal}_{\text{water}} = 8.35 \text{ lbf}$$

$$1 \text{ ft}^3_{\text{water}} = 7.48 \text{ gal}$$

**USNRC GENERIC FUNDAMENTALS EXAMINATION  
JUNE 2007 BWR--FORM A**

QUESTION: 1

Refer to the drawing of two identical water storage tanks (see figure below). Tank A is protected by a relief valve and Tank B is protected by a safety valve. Each valve has an opening setpoint of 205 psig and a maximum rated discharge flow rate of 8 gpm.

The tanks are being hydrostatically tested to 200 psig. Each tank is being supplied with a smooth and constant flow rate of 2 gpm from separate positive displacement pumps (PDPs). Both PDPs are inadvertently left running when tank pressures reach 200 psig.

With the PDPs running continuously, what will be the resulting status of the relief and safety valves?

- |    | <u>Relief Valve Status</u>                  | <u>Safety Valve Status</u>                  |
|----|---|---|
| A. | Partially open                              | Partially open                              |
| B. | Partially open                              | Cycling between fully open and fully closed |
| C. | Cycling between fully open and fully closed | Partially open                              |
| D. | Cycling between fully open and fully closed | Cycling between fully open and fully closed |

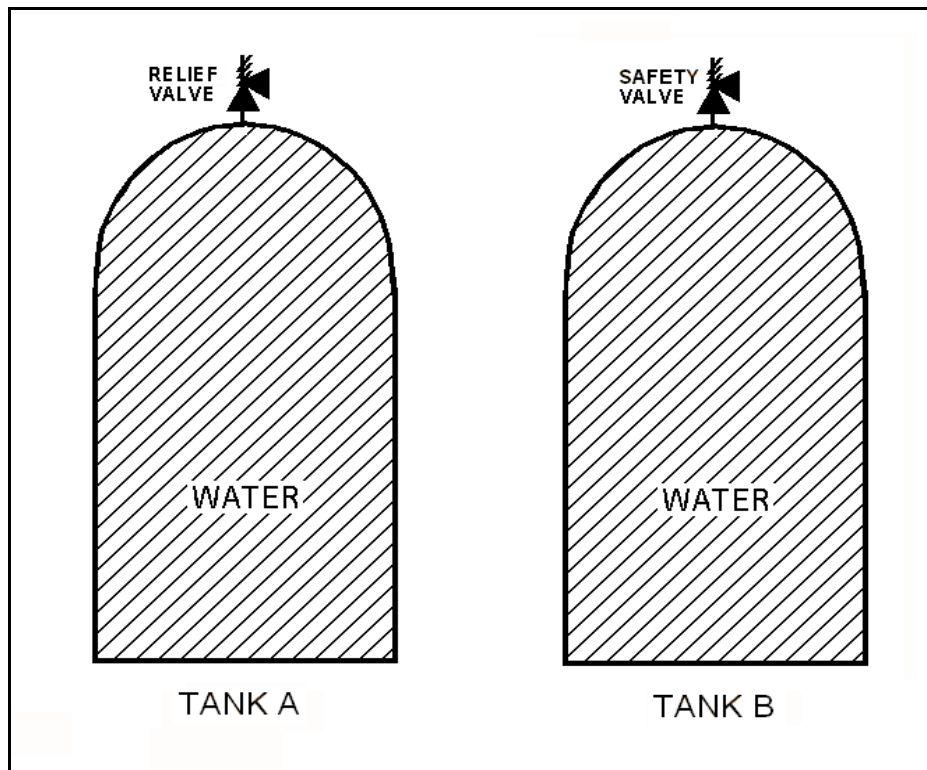

**USNRC GENERIC FUNDAMENTALS EXAMINATION  
JUNE 2007 BWR--FORM A**

QUESTION: 2

When transferring a valve controller from the manual mode to the automatic mode, the automatic valve controller output signal should be \_\_\_\_\_ the manual valve controller output signal at the time of transfer.

- A. equal to
- B. greater than
- C. less than
- D. increasing with

QUESTION: 3

Which one of the following describes the function and use of the backseat on a manual valve?

- A. Removes pressure from the packing/stuffing box and is typically used to isolate the stuffing box for valve repacking.
- B. Removes pressure from the packing/stuffing box and is typically used when needed to isolate packing leakage.
- C. Acts as a backup in case the primary seat leaks and is typically used during system isolation for personnel protection.
- D. Acts as a backup in case the primary seat leaks and is typically used when needed to prevent the primary seat from leaking excessively.

**USNRC GENERIC FUNDAMENTALS EXAMINATION  
JUNE 2007 BWR--FORM A**

QUESTION: 4

Refer to the drawing of a differential pressure (D/P) level detection system (see figure below) for a reactor vessel at normal operating temperature and pressure. The level detector has just been calibrated.

The high pressure side of the detector is connected to the \_\_\_\_\_; and if the equalizing valve is opened the indicated reactor vessel level will be \_\_\_\_\_ than the actual level.

- A. condensing chamber; lower
- B. condensing chamber; higher
- C. reactor vessel; lower
- D. reactor vessel; higher

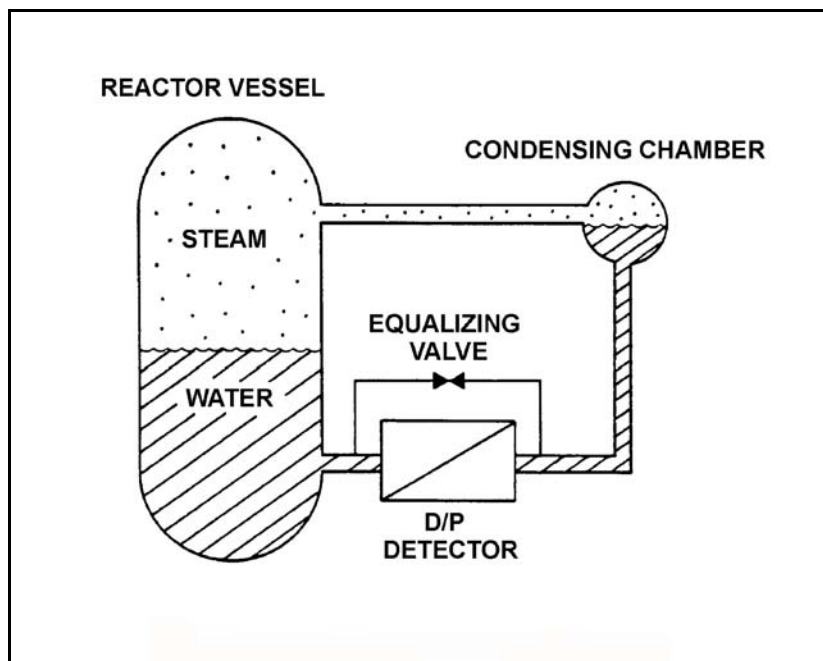

**USNRC GENERIC FUNDAMENTALS EXAMINATION  
JUNE 2007 BWR--FORM A**

QUESTION: 5

If the pressure sensed by a bourdon tube increases, the curvature of the detector will \_\_\_\_\_ because the greater force is being applied to the \_\_\_\_\_ curve of the detector.

- A. increase; outer
- B. increase; inner
- C. decrease; outer
- D. decrease; inner

**USNRC GENERIC FUNDAMENTALS EXAMINATION  
JUNE 2007 BWR--FORM A**

QUESTION: 6

Refer to the drawing of a simple thermocouple circuit (see figure below).

Thermocouple temperature indication is currently 350°F. A small steam leak occurs that raises reference (cold) junction temperature by 20°F. Assume measuring junction temperature remains constant. Without temperature compensation for the reference junction, the new temperature indication will be...

- A. 310°F.
- B. 330°F.
- C. 370°F.
- D. 390°F.

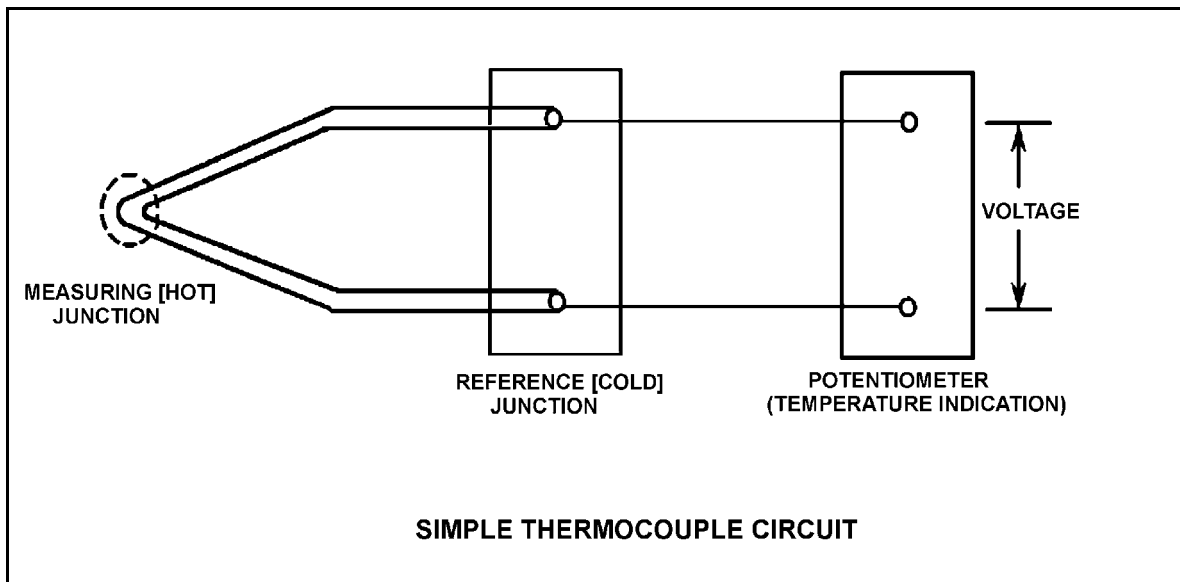



**USNRC GENERIC FUNDAMENTALS EXAMINATION  
JUNE 2007 BWR--FORM A**

QUESTION: 7

A beta particle and an alpha particle with equal kinetic energies cause ionization in a gas-filled radiation detector. The detector is operating in the ion chamber region of the gas ionization curve. Which one of the following describes the amplitudes of the detector pulses caused by each type of radiation?

- A. The beta particle pulse will be larger in amplitude.
- B. The alpha particle pulse will be larger in amplitude.
- C. The amplitudes of both pulses will be approximately equal for all detector voltages in the ion chamber region.
- D. The amplitudes of both pulses will be approximately equal for all detector voltages in the ion chamber region, as well as all detector voltages outside the ion chamber region.

QUESTION: 8

The water level in a water storage tank is being controlled by an automatic bistable level controller. If water level increases to 70%, the controller bistable turns on to open a tank drain valve. When water level decreases to 60%, the controller bistable turns off to close the drain valve.

Which one of the following bistable symbols indicates the characteristics of the bistable used in the level controller?

- A. 1.
- B. 2.
- C. 3.
- D. 4.

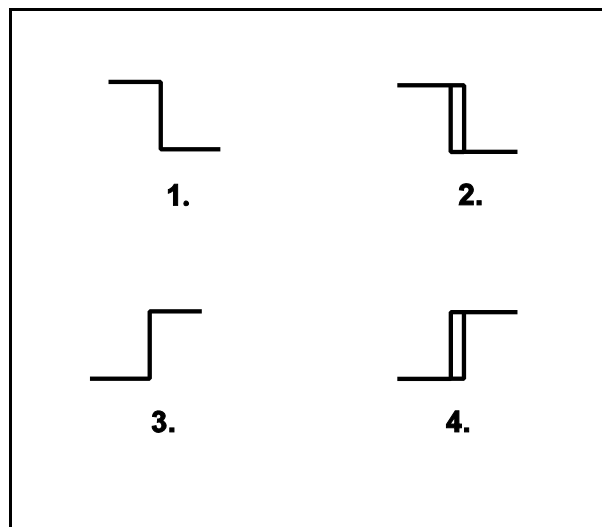

**USNRC GENERIC FUNDAMENTALS EXAMINATION  
JUNE 2007 BWR--FORM A**

QUESTION: 9

Which one of the following describes the operation of a typical pneumatic valve positioner?

- A. Compares the valve controller demand signal with actual valve position and sends an error signal to the valve controller for adjustment of the demand signal.
- B. Compares the valve controller automatic and manual setpoints and sends an error signal to the valve controller to ensure the manual demand signal is tracking the automatic demand signal.
- C. Receives a valve position error signal from the valve controller and positions the valve as necessary to null the valve position error signal.
- D. Receives a demand signal from the valve controller and supplies the appropriate air pressure to the valve actuator to move the valve to the demanded position.

**USNRC GENERIC FUNDAMENTALS EXAMINATION  
JUNE 2007 BWR--FORM A**

QUESTION: 10

Consider a centrifugal pump that is taking suction from the bottom of an open water storage tank. (See figure below.)

Given:

The tank contains 60°F water.

The eye of the pump impeller is located 50 feet above the bottom of the tank.

The pump requires a minimum net positive suction head of 4 feet.

Which one of the following describes the effect on pump operation if tank water level is allowed to continuously decrease?

- A. The pump will operate normally until tank water level decreases below approximately 20 feet, at which time the pump will cavitate.
- B. The pump will operate normally until tank water level decreases below approximately 16 feet, at which time the pump will cavitate.
- C. The pump will operate normally until the pump suction becomes uncovered, at which time the pump will cavitate.
- D. The pump will operate normally until the pump suction becomes uncovered, at which time the pump will become air bound.

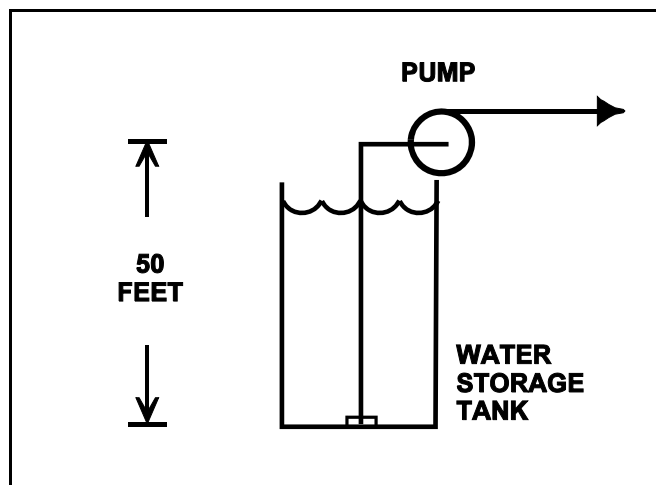

**USNRC GENERIC FUNDAMENTALS EXAMINATION  
JUNE 2007 BWR--FORM A**

QUESTION: 11

Refer to the drawing of an operating cooling water system (see figure below).

Which one of the following will increase available net positive suction head for the centrifugal pump?

- A. Draining the surge tank to decrease level by 10%.
- B. Positioning heat exchanger service water valve "B" more closed.
- C. Positioning pump discharge valve "C" more closed.
- D. Positioning pump suction valve "D" more closed.

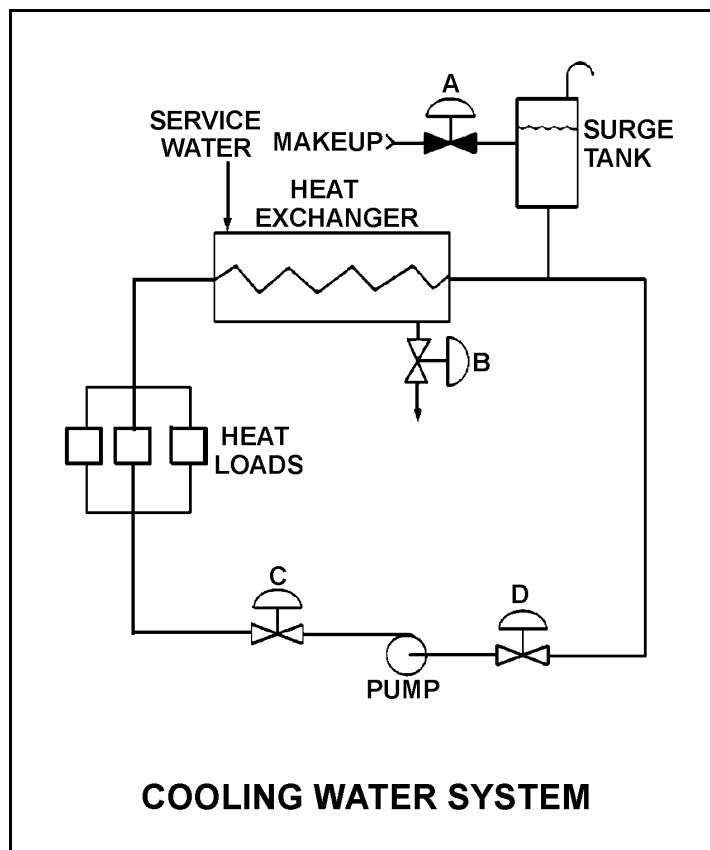

**USNRC GENERIC FUNDAMENTALS EXAMINATION  
JUNE 2007 BWR--FORM A**

QUESTION: 12

An ac motor-driven centrifugal water pump was just started. During the start, motor current remained peaked for 2 seconds, and then decreased and stabilized at about one-fifth the standard running current. Normally, the starting current peak lasts about 4 seconds.

Which one of the following could have caused the abnormal start indications above?

- A. The pump shaft was initially seized and the motor breaker opened.
- B. The pump was initially rotating slowly in the reverse direction.
- C. The pump was initially air bound, and then primed itself after 2 seconds of operation.
- D. The coupling between the motor and pump shafts was left unfastened after maintenance.

QUESTION: 13

What is the purpose of the safety/relief valve located between the pump outlet and the discharge isolation valve of most positive displacement pumps?

- A. Protect the pump and suction piping from overpressure if the discharge valve is open during system startup.
- B. Protect the pump and suction piping from overpressure if the suction valve is closed during pump operation.
- C. Protect the pump and discharge piping from overpressure if the discharge valve is closed during pump operation.
- D. Protect the pump and discharge piping from overpressure due to thermal expansion of pump contents when the pump is stopped with its suction valve closed.

**USNRC GENERIC FUNDAMENTALS EXAMINATION  
JUNE 2007 BWR--FORM A**

QUESTION: 14

A centrifugal pump is operating with the following parameters:

Speed = 1,800 rpm  
Current = 40 amperes  
Pump head = 20 psi  
Pump flow rate = 400 gpm

Which one of the following will be the new value of pump head and current if the speed is increased to 2,000 rpm?

- A. 22 psi, 44 amps
- B. 25 psi, 49 amps
- C. 22 psi, 49 amps
- D. 25 psi, 55 amps

QUESTION: 15

What is the significance of a 0.8 power factor when describing the output of a generator?

- A. 80% of the generator output is being converted to useful power.
- B. 80% of the generator output is being consumed by reactive loads.
- C. The generator is operating at 80% of its maximum rated output.
- D. The generator is 80% efficient at converting mechanical power to electrical power.

**USNRC GENERIC FUNDAMENTALS EXAMINATION  
JUNE 2007 BWR--FORM A**

QUESTION: 16

The rate of heat transfer between two liquids in a heat exchanger will be increased if the: (Assume single-phase conditions and a constant specific heat.)

- A. temperature of the hotter liquid is decreased by 20°F.
- B. temperature of the colder liquid is increased by 20°F.
- C. flow rates of both liquids are decreased by 10%.
- D. flow rates of both liquids are increased by 10%.

USNRC GENERIC FUNDAMENTALS EXAMINATION  
JUNE 2007 BWR--FORM A

QUESTION: 17

Refer to the drawing of an operating water cleanup system (see figure below).

All valves are identical and are initially 50% open. To lower the temperature at point 4, the operator can adjust valve \_\_\_\_\_ in the \_\_\_\_\_ direction.

- A. A; open
- B. B; shut
- C. C; open
- D. D; shut

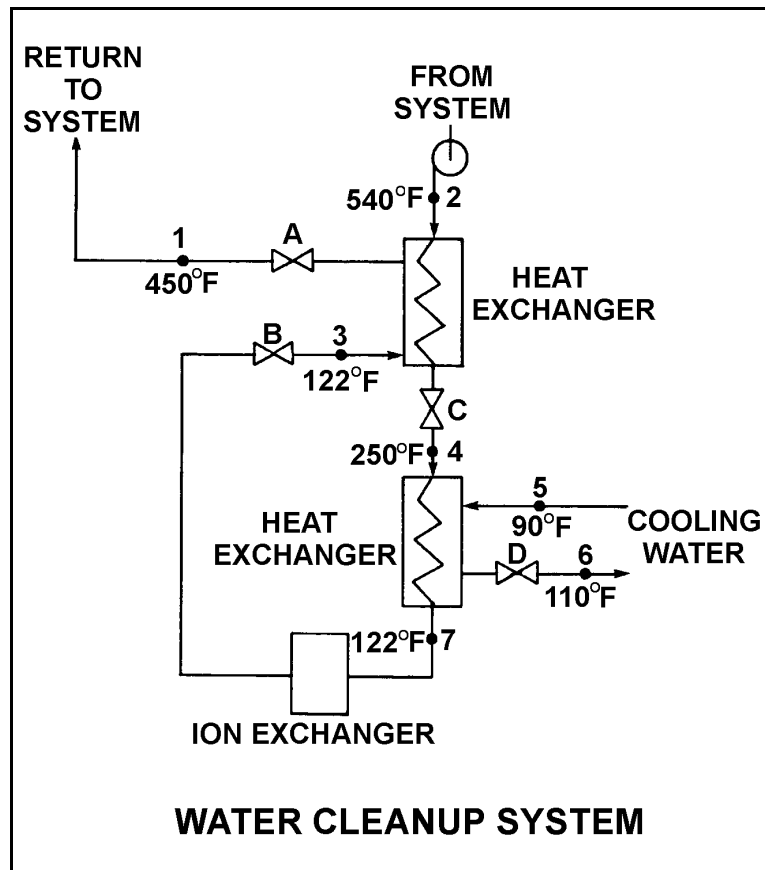



**USNRC GENERIC FUNDAMENTALS EXAMINATION  
JUNE 2007 BWR--FORM A**

QUESTION: 18

Refer to the drawing of an operating lube oil heat exchanger (see figure below).

If deposits accumulate on the outside of the cooling water tubes, cooling water outlet temperature will \_\_\_\_\_ and oil outlet temperature will \_\_\_\_\_. (Assume oil and cooling water inlet temperatures and flow rates remain the same.)

- A. increase; increase
- B. increase; decrease
- C. decrease; increase
- D. decrease; decrease

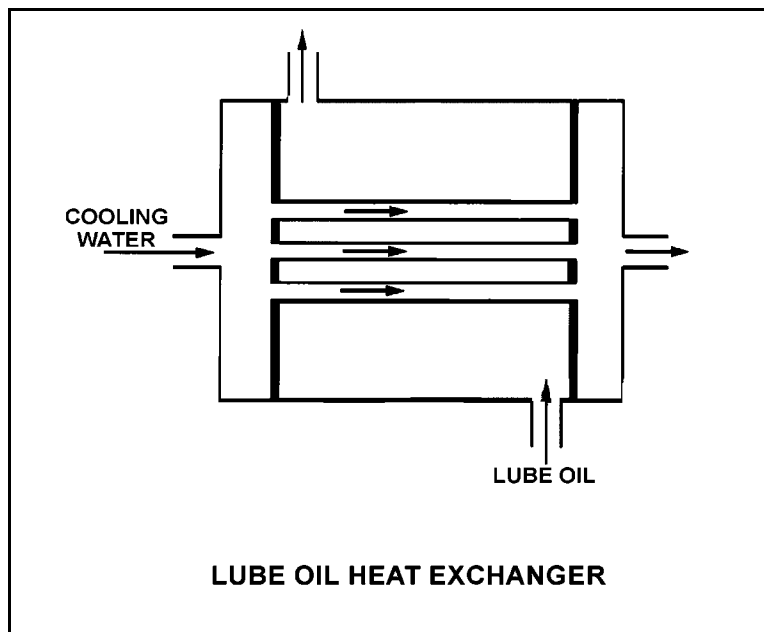

**USNRC GENERIC FUNDAMENTALS EXAMINATION  
JUNE 2007 BWR--FORM A**

QUESTION: 19

What percentage of ionic impurities is being removed from the water passing through an ion exchanger if the ion exchanger has a decontamination factor of 1.0?

- A. 100%
- B. 99%
- C. 1%
- D. 0%

QUESTION: 20

An operating nuclear power plant uses a mixed-resin deep-bed demineralizer to purify condensate. Condensate temperature gradually increases from 90°F to 110°F while the mass flow rate of condensate through the demineralizer remains the same.

As a result of the condensate temperature increase, the demineralizer will be \_\_\_\_\_ efficient at removing ionic impurities; and the demineralizer will experience a \_\_\_\_\_ pressure drop.

- A. more; higher
- B. more; lower
- C. less; higher
- D. less; lower

**USNRC GENERIC FUNDAMENTALS EXAMINATION  
JUNE 2007 BWR--FORM A**

QUESTION: 21

A typical 120 Vac manual circuit breaker has tripped due to overload. To close this circuit breaker the handle must be moved from the...

- A. OFF position directly to the ON position; trip latch reset is not required.
- B. midposition directly to the ON position; trip latch reset is not required.
- C. OFF position to the midposition to reset the trip latch, and then to the ON position.
- D. midposition to the OFF position to reset the trip latch, and then to the ON position.

**USNRC GENERIC FUNDAMENTALS EXAMINATION  
JUNE 2007 BWR--FORM A**

QUESTION: 22

Refer to the drawing of a valve motor control circuit (see figure below) for a valve that is currently fully open and has a 10-second stroke time.

**Note:** Limit switch (LS) contacts are shown open regardless of valve position, but relay contacts follow the standard convention for control circuit drawings.

The operator takes the control switch to “Close”. Two seconds later, after verifying the valve is closing, the operator releases the control switch. Which one of the following describes the valve motor control circuit alarm response after the switch is released?

- A. The alarm will continue to actuate for approximately 8 seconds.
- B. The alarm will continue to actuate until additional operator action is taken.
- C. The alarm will actuate after approximately 8 seconds.
- D. The alarm will not actuate until additional operator action is taken.

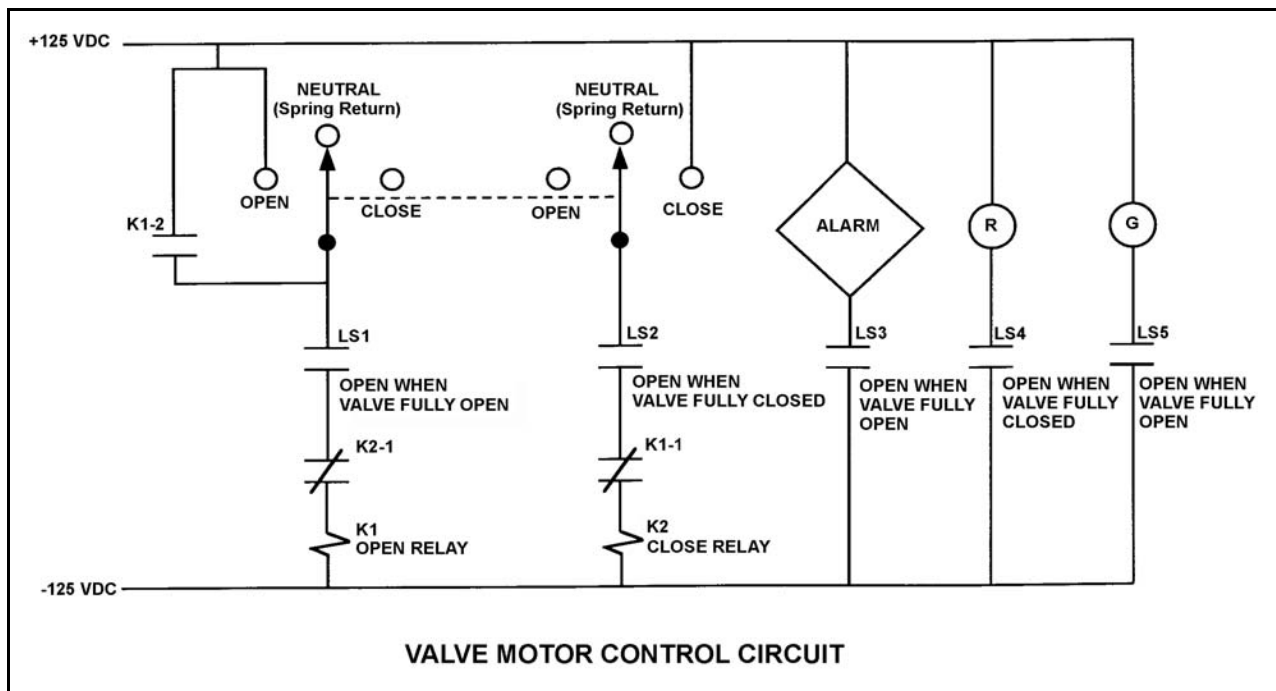

**USNRC GENERIC FUNDAMENTALS EXAMINATION  
JUNE 2007 BWR--FORM A**

QUESTION: 23

The ideal moderator has a \_\_\_\_\_ macroscopic absorption cross section for thermal neutrons and a \_\_\_\_\_ average logarithmic energy decrement.

- A. large; small
- B. large; large
- C. small; small
- D. small; large

QUESTION: 24

A nuclear reactor was initially operating at steady state 100% power when it was shut down and cooled down to 200 °F over a three-day period.

Given the following absolute values of reactivities added during the shutdown and cooldown, assign a (+) or (-) as appropriate and choose the current value of core reactivity.

Control rods	= ( ) 12.50% $\Delta K/K$
Voids	= ( ) 3.50% $\Delta K/K$
Xenon	= ( ) 2.50% $\Delta K/K$
Fuel temperature	= ( ) 2.00% $\Delta K/K$
Moderator temperature	= ( ) 0.50% $\Delta K/K$

- A. -3.0%  $\Delta K/K$
- B. -4.0%  $\Delta K/K$
- C. -8.0%  $\Delta K/K$
- D. -9.0%  $\Delta K/K$

**USNRC GENERIC FUNDAMENTALS EXAMINATION  
JUNE 2007 BWR--FORM A**

QUESTION: 25

A nuclear power plant was initially shutdown with a stable source range count rate of 30 cps. Using many small additions of positive reactivity, a total of 0.1%  $\Delta K/K$  was added to the core and stable source range count rate is currently 60 cps.

What was the stable source range count rate after 0.05%  $\Delta K/K$  was added to the core?

- A. 40 cps
- B. 45 cps
- C. 50 cps
- D. 55 cps

QUESTION: 26

If the average temperature of a fuel pellet decreases by 50°F, the microscopic cross-section for absorption of neutrons at a resonance energy of U-238 will \_\_\_\_\_; and the microscopic cross-sections for absorption of neutrons at energies that are slightly higher or lower than a U-238 resonance energy will \_\_\_\_\_.

- A. increase; increase
- B. increase; decrease
- C. decrease; increase
- D. decrease; decrease

**USNRC GENERIC FUNDAMENTALS EXAMINATION  
JUNE 2007 BWR--FORM A**

QUESTION: 27

Which one of the following describes why most reactor power is produced in the lower half of a core (versus the upper half) that has been operating at 100% power for several weeks at the beginning of a fuel cycle?

- A. Xenon concentration is higher in the upper half of the core.
- B. The moderator-to-fuel ratio is higher in the upper half of the core.
- C. The void coefficient is adding more negative reactivity in the upper half of the core.
- D. Control rods are adding more negative reactivity in the upper half of the core.

QUESTION: 28

Criticality has been achieved during a xenon-free nuclear reactor startup. The core neutron flux level is low in the intermediate range and a stable positive 60-second reactor period has been established. The operator begins inserting control rods in an effort to stabilize the core neutron flux level near its current value. The operator stops inserting control rods exactly when the reactor period indicates infinity.

Immediately after the operator stops inserting the control rods, the reactor period will become \_\_\_\_\_ ; and the core neutron flux level will \_\_\_\_\_.

- A. positive; increase exponentially
- B. positive; increase linearly
- C. negative; decrease exponentially
- D. negative; decrease linearly

**USNRC GENERIC FUNDAMENTALS EXAMINATION  
JUNE 2007 BWR--FORM A**

QUESTION: 29

Which one of the following expresses the relationship between differential rod worth (DRW) and integral rod worth (IRW)?

- A. DRW is the area under the IRW curve at a given rod position.
- B. DRW is the slope of the IRW curve at a given rod position.
- C. DRW is the IRW at a given rod position.
- D. DRW is the square root of the IRW at a given rod position.

QUESTION: 30

A nuclear reactor is operating at 100% power with equilibrium core xenon-135 near the beginning of a fuel cycle when a scram occurs. When the reactor is taken critical 5 hours later, xenon distribution will be maximum at the \_\_\_\_\_ of the core.

- A. bottom and center
- B. bottom and outer circumference
- C. top and center
- D. top and outer circumference



**USNRC GENERIC FUNDAMENTALS EXAMINATION  
JUNE 2007 BWR--FORM A**

QUESTION: 31

A nuclear reactor that had been operating at 100% power for about two months was shutdown over a 2-hour period. Following the shutdown, core xenon-135 will reach a long-term steady-state concentration in \_\_\_\_\_ hours.

- A. 8 to 10
- B. 20 to 25
- C. 40 to 50
- D. 70 to 80

**USNRC GENERIC FUNDAMENTALS EXAMINATION  
JUNE 2007 BWR--FORM A**

QUESTION: 32

Refer to the curve of  $K_{\text{eff}}$  versus core age for an operating nuclear reactor (see figure below).

The reactor has been operating at 100% power for several weeks and is currently operating between points 2 and 3 on the curve.

Assuming reactor recirculation flow rate remains the same, what general control rod operation will be necessary to maintain the reactor operating at 100% power until point 3 is reached?

- A. Withdrawal for the entire period.
- B. Withdrawal at first, then insertion.
- C. Insertion for the entire period.
- D. Insertion at first, then withdrawal.

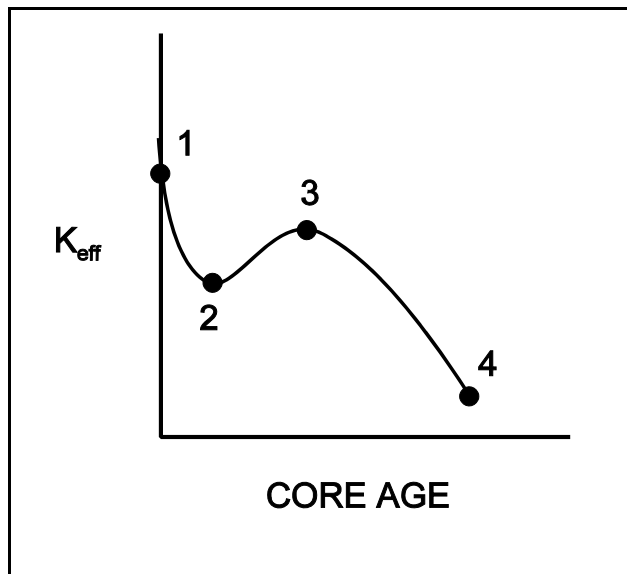

**USNRC GENERIC FUNDAMENTALS EXAMINATION  
JUNE 2007 BWR--FORM A**

QUESTION: 33

A nuclear reactor startup is in progress with  $K_{\text{eff}}$  at 0.999 and stable source range indication. If a control rod is withdrawn one notch reactor period will initially become \_\_\_\_\_; and then \_\_\_\_\_. (Assume  $K_{\text{eff}}$  remains less than 1.0.)

- A. positive; approach infinity
- B. positive; stabilize at a positive value
- C. negative; approach infinity
- D. negative; stabilize at a negative value

QUESTION: 34

A nuclear reactor is initially stable at the point of adding heat (POAH) with a reactor coolant temperature of 160°F during the reactor heat-up and pressurization phase of a reactor startup. Control rods are withdrawn a few notches to raise reactor power and establish a heat-up rate. Assume no core voiding occurs.

If no further control rod withdrawal occurs, reactor power will initially increase, and then...

- A. remain stable until voiding begins to occur.
- B. continue to increase until the control rods are reinserted.
- C. decrease and stabilize at a subcritical power level.
- D. decrease and stabilize at the POAH.

**USNRC GENERIC FUNDAMENTALS EXAMINATION  
JUNE 2007 BWR--FORM A**

QUESTION: 35

A nuclear reactor is critical and a reactor coolant heat-up is in progress with coolant temperature currently at 140°F. If the point of adding heat is initially 1% reactor power, and reactor power is held constant at 3% during the heat-up, which one of the following describes the coolant heat-up rate (HUR) from 140°F to 200°F?

- A. HUR will initially decrease and then increase.
- B. HUR will slowly decrease during the entire period.
- C. HUR will slowly increase during the entire period.
- D. HUR will remain the same during the entire period.

QUESTION: 36

A nuclear power plant is operating at 90% of rated power near the end of a fuel cycle. If a turbine control system malfunction opens the turbine control valves an additional 5 percent, reactor power will initially...

- A. increase due to positive reactivity addition from the void coefficient only.
- B. increase due to positive reactivity addition from the void and moderator temperature coefficients.
- C. decrease due to negative reactivity addition from the void coefficient only.
- D. decrease due to negative reactivity addition from the void and moderator temperature coefficients.

**USNRC GENERIC FUNDAMENTALS EXAMINATION  
JUNE 2007 BWR--FORM A**

QUESTION: 37

Refer to the drawing of four tank differential pressure level detectors (see figure below).

The tanks are identical and are being maintained at 30 psia and a water level of 20 feet. They are surrounded by standard atmospheric pressure. The water in the tank and reference leg is at 70°F.

If each detector experiences a ruptured diaphragm, which detector(s) will cause indicated tank level to increase? (Assume actual tank water level remains constant.)

- A. No. 1 only
- B. No. 2 only
- C. No. 1 and 3
- D. No. 2 and 4

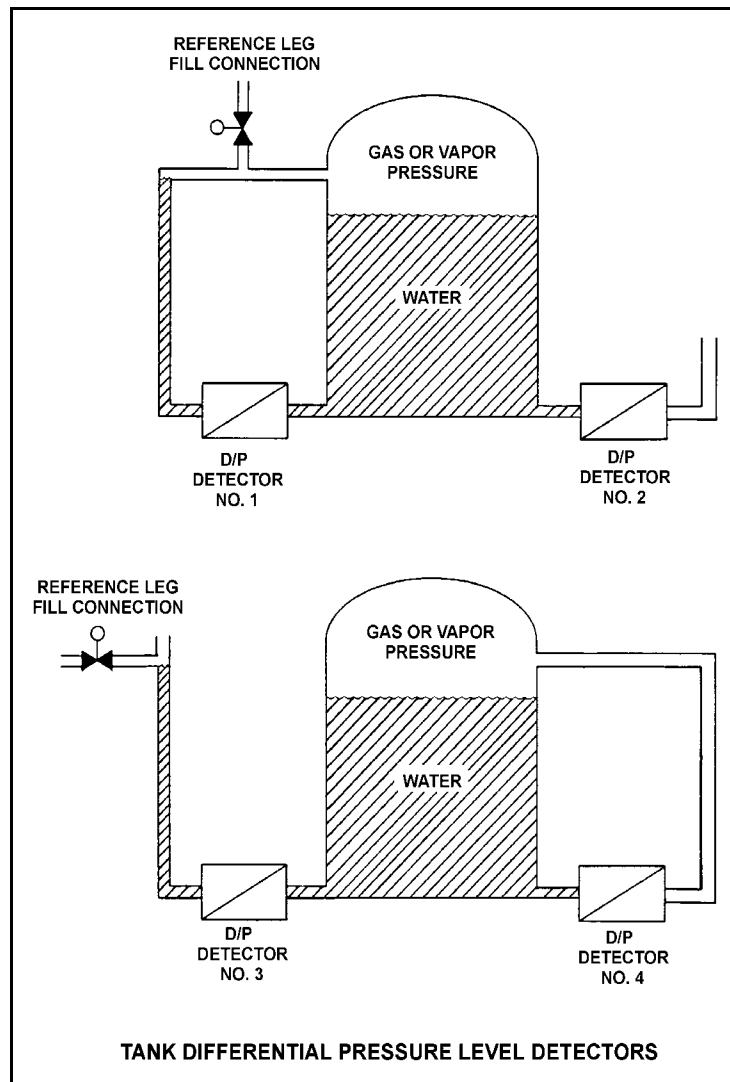

**USNRC GENERIC FUNDAMENTALS EXAMINATION  
JUNE 2007 BWR--FORM A**

QUESTION: 38

Saturated steam enters a frictionless convergent-divergent nozzle with the following parameters:

Pressure = 850 psia

Velocity = 10 ft/sec

The steam at the throat of the nozzle has a subsonic velocity of 950 ft/sec.

Given that nozzles convert enthalpy to kinetic energy, and assuming no heat transfer to or from the nozzle, what is the enthalpy of the steam at the throat of the nozzle?

- A. 1,162 Btu/lbm
- B. 1,171 Btu/lbm
- C. 1,180 Btu/lbm
- D. 1,189 Btu/lbm

**USNRC GENERIC FUNDAMENTALS EXAMINATION  
JUNE 2007 BWR--FORM A**

QUESTION: 39

A nuclear power plant is operating at 90% of rated power. Main condenser pressure is 1.69 psia and hotwell condensate temperature is 120°F.

Which one of the following describes the effect of a 5% decrease in cooling water flow rate through the main condenser?

- A. Overall steam cycle thermal efficiency will increase because the work output of the turbine will increase.
- B. Overall steam cycle thermal efficiency will increase because condensate depression will decrease.
- C. Overall steam cycle thermal efficiency will decrease because the work output of the turbine will decrease.
- D. Overall steam cycle thermal efficiency will decrease because condensate depression will increase.

QUESTION: 40

A steam plant main turbine consists of a high-pressure (HP) unit and several low-pressure (LP) units. The main turbine is most likely to experience stress-related failures of the rotor blades in the \_\_\_\_\_ stages of the \_\_\_\_\_ unit(s).

- A. inlet; HP
- B. inlet; LP
- C. outlet; HP
- D. outlet; LP

**USNRC GENERIC FUNDAMENTALS EXAMINATION  
JUNE 2007 BWR--FORM A**

QUESTION: 41

Refer to the drawing of a cooling water system (see figure below).

Pumps A and B are identical single-speed centrifugal pumps, but only pump A is operating. Assume real (non-ideal) system and pump operating characteristics.

If pump B is started, system flow rate will \_\_\_\_\_ and the total pump head will \_\_\_\_\_.

- A. increase; increase
- B. increase; remain the same
- C. remain the same; increase
- D. remain the same; remain the same

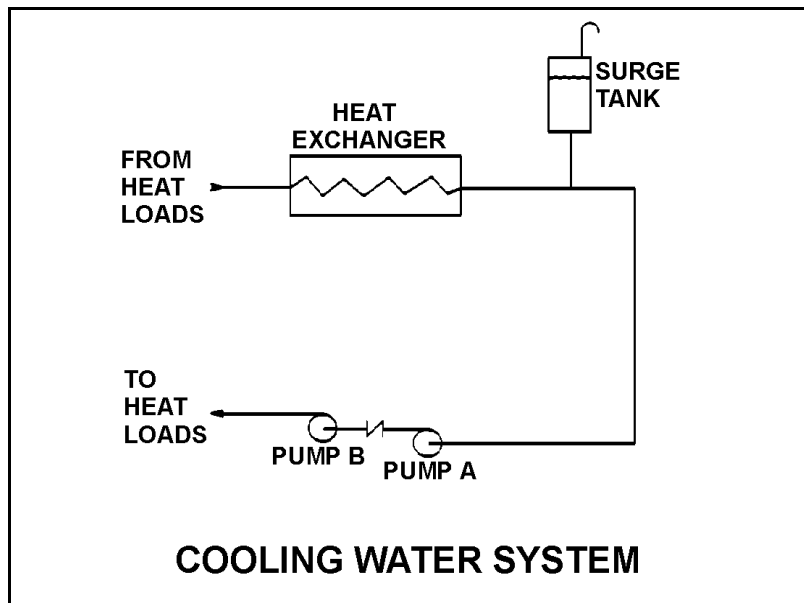



**USNRC GENERIC FUNDAMENTALS EXAMINATION  
JUNE 2007 BWR--FORM A**

QUESTION: 42

A length of pipe in a cooling water system uses a reducer fitting to decrease the pipe diameter from 6 inches to 4 inches. The flow rate in the 6-inch diameter section of pipe is 200 gpm. What is the flow rate in the 4-inch diameter section of pipe?

- A. 133 gpm
- B. 200 gpm
- C. 300 gpm
- D. 450 gpm

QUESTION: 43

Which one of the following describes a heat transfer flow path in which conduction is the most significant heat transfer mechanism?

- A. From the reactor fuel to the core barrel during core uncover.
- B. From the main turbine exhaust steam to the atmosphere via main condenser cooling water and a cooling tower during normal operation.
- C. From the reactor fuel to the steam outlet of the reactor vessel during a station blackout.
- D. From a fuel pellet to the fuel clad via the fuel rod fill gas during normal operation.

**USNRC GENERIC FUNDAMENTALS EXAMINATION  
JUNE 2007 BWR--FORM A**

QUESTION: 44

A nuclear power plant is currently shut down after several months of operation at full power. The shutdown cooling system is in operation, maintaining an average reactor coolant temperature of 280°F. A pressure control malfunction causes RCS pressure to slowly and continuously decrease from 100 psia while reactor coolant temperature remains constant. (Assume a normal reactor coolant flow direction through the core.)

Which one of the following describes where nucleate boiling will first occur?

- A. At a scratch on the surface of a fuel rod near the top of a fuel assembly.
- B. At a scratch on the surface of a fuel rod near the bottom of a fuel assembly.
- C. In the bulk fluid of a coolant channel near the top of a fuel assembly.
- D. In the bulk fluid of a coolant channel near the bottom of a fuel assembly.

QUESTION: 45

How does critical heat flux vary from the bottom to the top of a typical fuel bundle during normal full power operation?

- A. Decreases continuously
- B. Decreases, then increases
- C. Increases continuously
- D. Increases, then decreases

**USNRC GENERIC FUNDAMENTALS EXAMINATION  
JUNE 2007 BWR--FORM A**

QUESTION: 46

Carry-under is most damaging to which one of the following components?

- A. Main turbine
- B. Moisture separator (turbine)
- C. Recirculation pump
- D. Moisture separator (reactor vessel)

QUESTION: 47

A nuclear reactor is operating at 3,400 MW thermal power. The linear heat generation rate (LHGR) limit is 14.7 kW/ft.

Given:

- The reactor core contains 640 fuel bundles.
- Each bundle contains 62 fuel rods, each with an active length of 12.5 feet
- The highest total peaking factors are at the following core locations:

Location A: 2.4

Location B: 2.3

Location C: 2.2

Location D: 2.1

Which one of the following describes the operating conditions in the core relative to the LHGR limit?

- A. All locations in the core are operating below the LHGR limit.
- B. Location A has exceeded the LHGR limit while the remainder of the core is operating below the limit.
- C. Locations A and B have exceeded the LHGR limit while the remainder of the core is operating below the limit.
- D. Locations A, B, and C have exceeded the LHGR limit while the remainder of the core is operating below the limit.

**USNRC GENERIC FUNDAMENTALS EXAMINATION  
JUNE 2007 BWR--FORM A**

QUESTION: 48

Which one of the following describes the fuel-to-coolant thermal conductivity for a fuel assembly at the beginning of a fuel cycle (BOC) as compared to the end of a fuel cycle (EOC)?

- A. Larger at BOC due to a higher fuel pellet density.
- B. Larger at BOC due to lower contamination of fuel rod fill gas with fission product gases.
- C. Smaller at BOC due to a larger gap between the fuel pellets and clad.
- D. Smaller at BOC due to a smaller corrosion film on the surface of the fuel rods.

QUESTION: 49

A nuclear power plant is operating at 90% power near the end of a fuel cycle when the turbine control system opens the turbine control valves an additional 5 percent. Assuming the reactor does not scram immediately, critical power ratio will initially \_\_\_\_\_ due to a(n) \_\_\_\_\_ latent heat of vaporization.

- A. increase; increased
- B. increase; decreased
- C. decrease; increased
- D. decrease; decreased

**USNRC GENERIC FUNDAMENTALS EXAMINATION  
JUNE 2007 BWR--FORM A**

QUESTION: 50

Which one of the following will prevent brittle fracture failure of a reactor vessel?

- A. Manufacturing the reactor vessel from low carbon steel.
- B. Maintaining reactor vessel pressure below the maximum design limit.
- C. Operating above the reference temperature for nil-ductility transition ( $RT_{NDT}$ ).
- D. Maintaining the number of reactor vessel heatup/cool-down cycles within limits.

**\*\*\*FINAL ANSWER KEY \*\*\***

**JUNE 2007 NRC GENERIC FUNDAMENTALS EXAMINATION  
BOILING WATER REACTOR - ANSWER KEY**

<u>FORM A</u>	<u>FORM B</u>	<u>ANS.</u>	<u>FORM A</u>	<u>FORM B</u>	<u>ANS.</u>
1	15	B	26	40	B
2	16	A	27	41	C
3	17	B	28	42	A
4	18	B	29	43	B
5	19	C	30	44	A
6	20	B	31	45	D
7	21	B	32	46	C
8	22	D	33	47	A
9	23	D	34	48	D
10	24	A	35	49	B
11	25	C	36	50	C
12	26	D	37	1	A
13	27	C	38	2	C
14	28	D	39	3	C
15	29	A	40	4	D
16	30	D	41	5	A
17	31	B	42	6	B
18	32	C	43	7	D
19	33	D	44	8	A
20	34	A or C	45	9	A
21	35	D	46	10	C
22	36	B	47	11	D
23	37	D	48	12	C
24	38	B	49	13	A
25	39	A	50	14	C