

TOPIC: 291006
KNOWLEDGE: K1.01 [2.7/2.7]
QID: B104

Which one of the following describes the proper sequence for placing a steam (shell) and water (tube) heat exchanger into service?

- A. The water side is valved in before the steam side to minimize thermal shock.
- B. The water side is valved in before the steam side to ensure adequate venting.
- C. The steam side is valved in before the water side to minimize scale buildup on the heat exchanger tubes.
- D. The steam side is valved in before the water side to ensure that the cooldown rate does not exceed 100°F/hr.

ANSWER: A.

TOPIC: 291006
KNOWLEDGE: K1.02 [2.6/2.6]
QID: B36

Why is proper venting of a shell-and-tube heat exchanger important?

- A. An air bubble reduces the heat transfer coefficient of the heat exchanger.
- B. An air bubble causes pressure transients within the tubes as heat load changes.
- C. An air bubble will cause thermal shock as it moves through the heat exchanger.
- D. An air bubble will cause corrosion in the heat exchanger.

ANSWER: A.

TOPIC: 291006
KNOWLEDGE: K1.02 [2.6/2.6]
QID: B531

A liquid-to-liquid heat exchanger containing trapped air on the shell side will be less efficient because the air...

- A. causes more turbulent fluid flow.
- B. increases the differential temperature across the tubes.
- C. reduces the fluid contact with the heat transfer surface.
- D. causes pressure oscillations.

ANSWER: C.

TOPIC: 291006
KNOWLEDGE: K1.02 [2.6/2.6]
QID: B932

Reduced heat transfer performance in a heat exchanger will result from...

- A. tube wall thinning.
- B. turbulent flow in the tubes.
- C. increased ΔT between fluids.
- D. gas collection in the shell.

ANSWER: D.

TOPIC: 291006
KNOWLEDGE: K1.03 [2.4/2.6]
QID: B631 (P1832)

The rate of heat transfer between two liquids in a heat exchanger will be increased if the: (Assume single-phase conditions and a constant specific heat for each liquid.)

- A. flow rate of the colder liquid is decreased by 10%.
- B. flow rate of the hotter liquid is increased by 10%.
- C. inlet temperature of both liquids is decreased by 20°F.
- D. inlet temperature of both liquids is increased by 20°F.

ANSWER: B.

TOPIC: 291006
KNOWLEDGE: K1.03 [2.4/2.6]
QID: B832 (P1632)

The rate of heat transfer between two liquids in a heat exchanger will be decreased if the: (Assume single-phase conditions and a constant specific heat capacity.)

- A. temperature of both liquids is decreased by 20°F.
- B. temperature of both liquids is increased by 20°F.
- C. flow rate of the colder liquid is decreased by 10%.
- D. flow rate of the hotter liquid is increased by 10%.

ANSWER: C.

TOPIC: 291006
KNOWLEDGE: K1.03 [2.4/2.6]
QID: B1432 (P1432)

The rate of heat transfer between two liquids in a heat exchanger will be increased if the: (Assume single-phase conditions and a constant specific heat.)

- A. temperature of the hotter liquid is decreased by 20°F.
- B. temperature of the colder liquid is increased by 20°F.
- C. flow rates of both liquids are decreased by 10%.
- D. flow rates of both liquids are increased by 10%.

ANSWER: D.

TOPIC: 291006
KNOWLEDGE: K1.03 [2.4/2.6]
QID: B1732 (P1732)

Which one of the following will reduce the rate of heat transfer between two liquids in a heat exchanger? (Assume single-phase conditions and a constant specific heat for both liquids.)

- A. The inlet temperatures of both liquids are decreased by 20°F.
- B. The inlet temperatures of both liquids are increased by 20°F.
- C. The inlet temperature of the hotter liquid is increased by 20°F.
- D. The inlet temperature of the colder liquid is increased by 20°F.

ANSWER: D.

TOPIC: 291006
KNOWLEDGE: K1.03 [2.4/2.6]
QID: B2531 (P2632)

The rate of heat transfer between two liquids in a heat exchanger will be decreased if the: (Assume single-phase conditions and a constant specific heat for both liquids.)

- A. inlet temperature of the hotter liquid is increased by 20°F.
- B. inlet temperature of the colder liquid is decreased by 20°F.
- C. flow rates of both liquids are decreased by 10%.
- D. flow rates of both liquids are increased by 10%.

ANSWER: C.

TOPIC: 291006
KNOWLEDGE: K1.03 [2.4/2.6]
QID: B3631 (P3632)

Refer to the drawing of an operating water cleanup system (see figure below).

If cooling water flow rate is 1.0×10^6 lbm/hr, what is the approximate water flow rate in the cleanup system?

- A. 2.2×10^5 lbm/hr
- B. 3.2×10^5 lbm/hr
- C. 2.2×10^6 lbm/hr
- D. 3.2×10^6 lbm/hr

ANSWER: A.

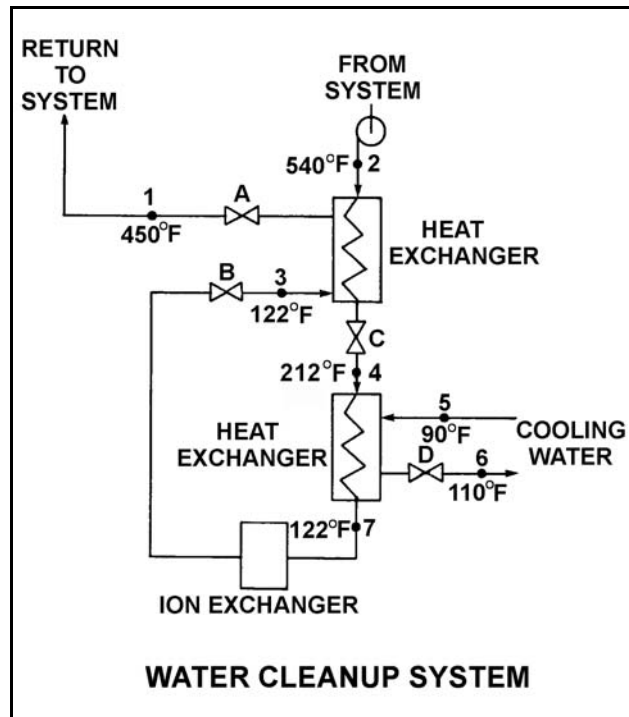

TOPIC: 291006
KNOWLEDGE: K1.04 [2.8/2.8]
QID: B632 (P3232)

Refer to the drawing of an operating water cleanup system (see figure below). Valves A, B, and D are fully open and valve C is 50% open.

If valve C is opened to 100%, how will the temperatures at points 3 and 6 be affected?

Point 3

Point 6

- | | |
|-------------|----------|
| A. Decrease | Decrease |
| B. Decrease | Increase |
| C. Increase | Decrease |
| D. Increase | Increase |

ANSWER: D.

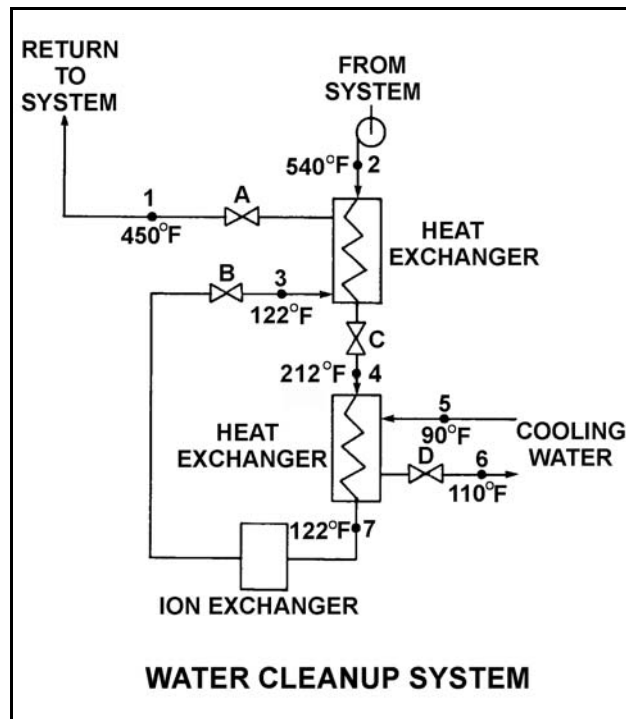

TOPIC: 291006
KNOWLEDGE: K1.04 [2.8/2.8]
QID: B1031 (P1032)

Refer to the following drawing of an operating water cleanup system. Valves A, B, and C are fully open. Valve D is 20% open. All temperatures are as shown.

If valve D is then opened to 100%, the temperature at point...

- A. 3 will increase.
- B. 4 will decrease.
- C. 5 will decrease.
- D. 7 will increase.

ANSWER: B.

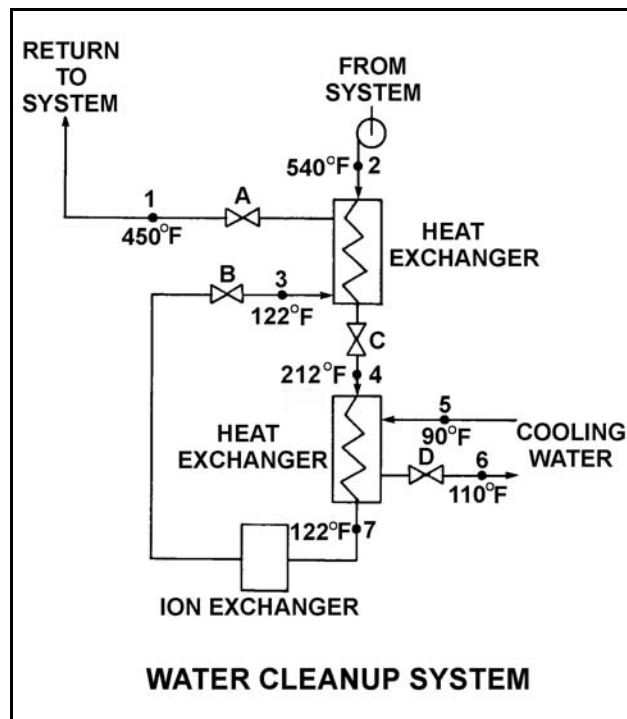

TOPIC: 291006
KNOWLEDGE: K1.04 [2.8/2.8]
QID: B1834 (P732)

Refer to the drawing of an operating water cleanup system (see figure below).

Valves A, B, and C are fully open. Valve D is 80% open. All temperatures are as shown. If valve D is then throttled to 50%, the temperature at point...

- A. 3 will decrease.
- B. 4 will increase.
- C. 5 will increase.
- D. 6 will decrease.

ANSWER: B.

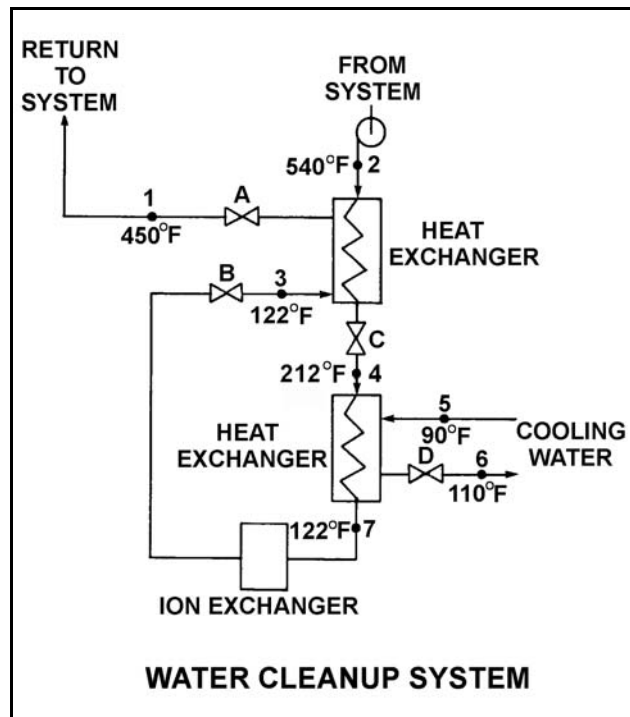

TOPIC: 291006
KNOWLEDGE: K1.04 [2.8/2.8]
QID: B1930 (P3332)

Refer to the drawing of an operating water cleanup system. All valves are identical and are initially 50% open (see figure below).

To raise the temperature at point 7, the operator should adjust valve _____ in the close direction.

- A. A
- B. B
- C. C
- D. D

ANSWER: D.

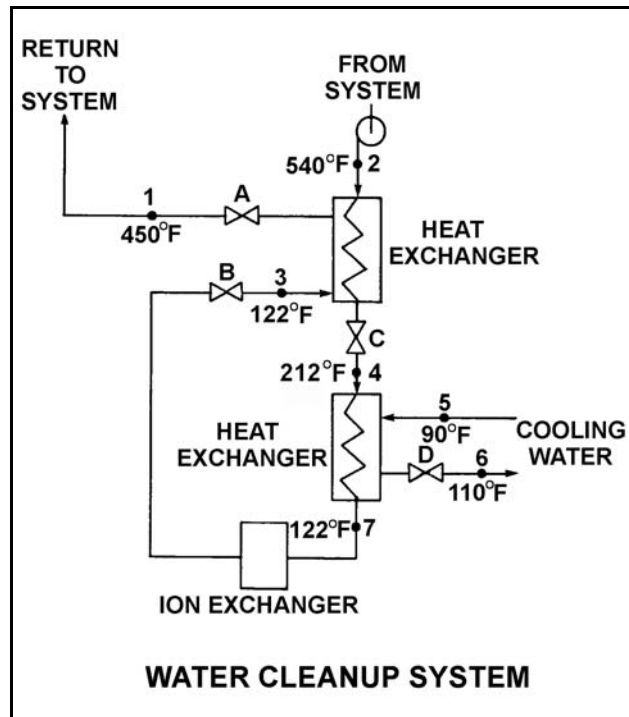

TOPIC: 291006
KNOWLEDGE: K1.07 [2.7/2.8]
QID: B31

Decreasing the temperature of the lube oil leaving a lube oil heat exchanger is normally accomplished by...

- A. increasing the cooling water flow rate.
- B. increasing the lube oil flow rate.
- C. decreasing the cooling water flow rate.
- D. decreasing the lube oil flow rate.

ANSWER: A.

TOPIC: 291006
KNOWLEDGE: K1.07 [2.9/3.0]
QID: B101

Refer to the drawing of an operating water cleanup system (see figure below).

All valves are identical and are initially 50% open. The temperature at point 3 is exceeding operating limits. To lower the temperature at point 3, the operator should adjust valve _____ in the open direction.

- A. A
- B. B
- C. C
- D. D

ANSWER: D.

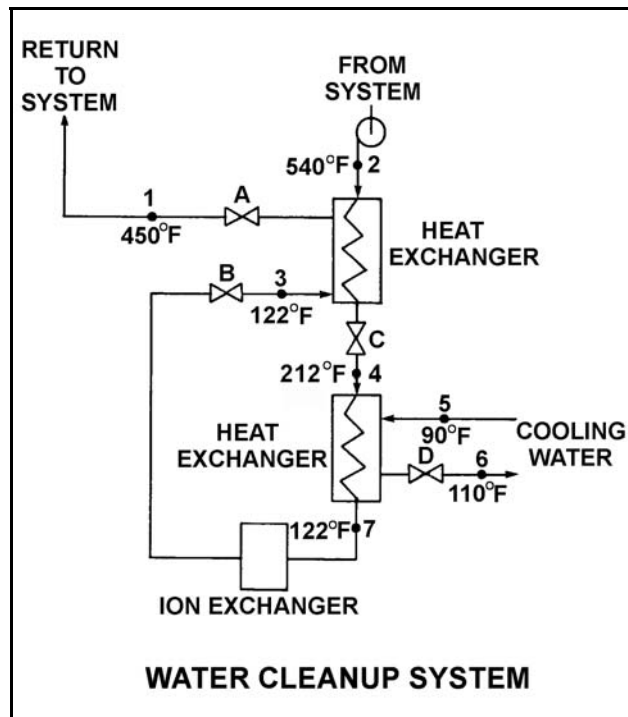

TOPIC: 291006
KNOWLEDGE: K1.07 [2.7/2.8]
QID: B231 (P104)

Refer to the drawing of an operating water cleanup system (see figure below).

All valves are identical and are initially 50% open. To lower the temperature at point 7, the operator can adjust valve _____ in the open direction.

- A. A
- B. B
- C. C
- D. D

ANSWER: D.

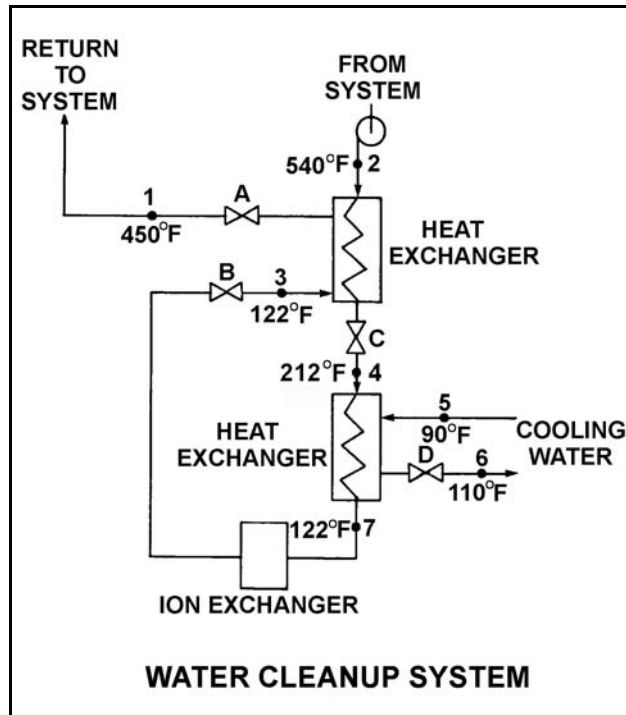

TOPIC: 291006
KNOWLEDGE: K1.07 [2.7/2.8]
QID: B1231 (P1231)

Refer to the drawing of an operating water cleanup system (see figure below).

All valves are identical and are initially 50% open. To lower the temperature at point 4, the operator can adjust valve _____ in the _____ direction.

- A. A; open
- B. B; shut
- C. C; open
- D. D; shut

ANSWER: B.

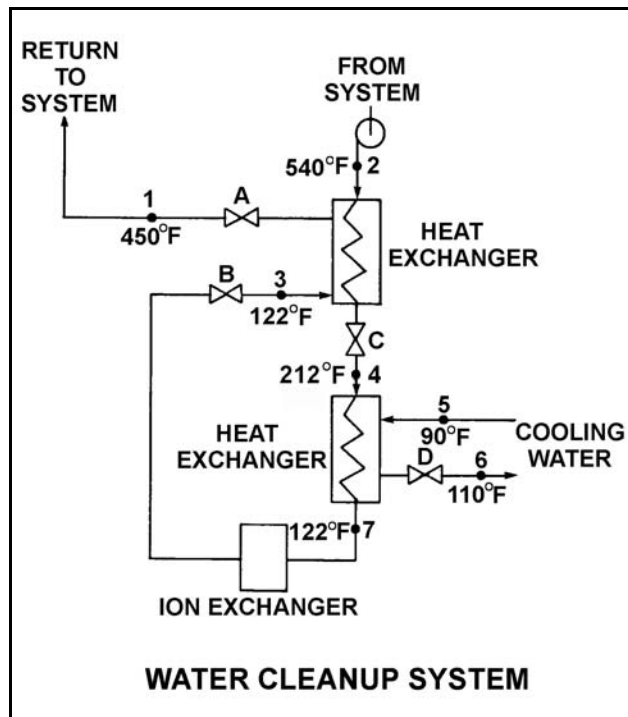

TOPIC: 291006
KNOWLEDGE: K1.07 [2.7/2.8]
QID: B2732 (P2732)

Refer to the drawing of an operating water cleanup system (see figure below).

All valves are identical and are initially 50% open. To raise the temperature at point 4, the operator can adjust valve _____ in the _____ direction.

- A. A; shut
- B. B; shut
- C. C; open
- D. D; open

ANSWER: C.

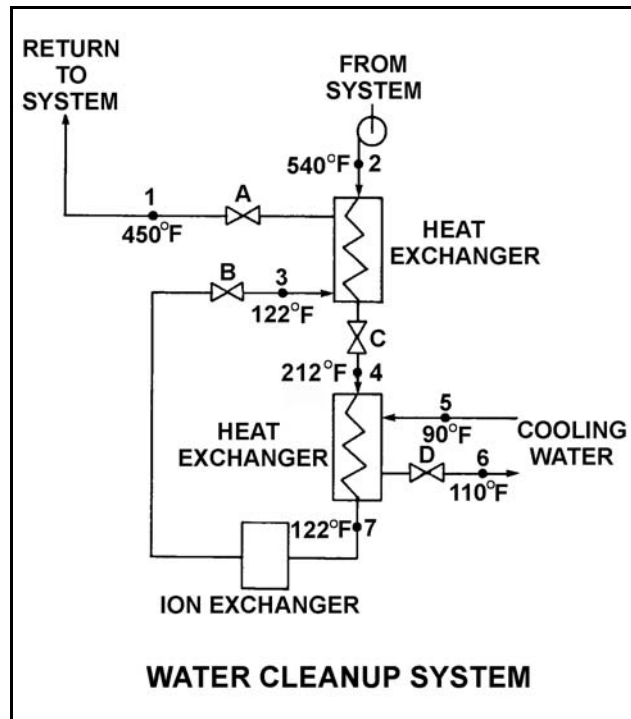

TOPIC: 291006
KNOWLEDGE: K1.07 [2.6/2.8]
QID: B3832 (P3833)

A main turbine-generator was operating at 80% load with the following initial steady-state lube oil and cooling water temperatures for the main turbine lube oil heat exchanger:

$$\begin{aligned}T_{\text{oil in}} &= 174^{\circ}\text{F} \\T_{\text{oil out}} &= 114^{\circ}\text{F} \\T_{\text{water in}} &= 85^{\circ}\text{F} \\T_{\text{water out}} &= 115^{\circ}\text{F}\end{aligned}$$

Six months later, the following current steady-state heat exchanger temperatures are observed:

$$\begin{aligned}T_{\text{oil in}} &= 177^{\circ}\text{F} \\T_{\text{oil out}} &= 111^{\circ}\text{F} \\T_{\text{water in}} &= 85^{\circ}\text{F} \\T_{\text{water out}} &= 115^{\circ}\text{F}\end{aligned}$$

Assume that the total heat exchanger heat transfer coefficient and the cooling water mass flow rate do not change, and that the specific heat values for the cooling water and lube oil do not change. Also, assume that the lube oil system is a closed system.

Which one of the following could be responsible for the differences between the initial and current steady-state heat exchanger temperatures?

- A. The current main turbine-generator load is lower than the initial load.
- B. The current main turbine-generator load is higher than the initial load.
- C. The current main turbine lube oil mass flow rate is less than the initial flow rate.
- D. The current main turbine lube oil mass flow rate is greater than the initial flow rate.

ANSWER: C.

TOPIC: 291006
KNOWLEDGE: K1.07 [2.6/2.8]
QID: B5317 (P5316)

A main turbine-generator was operating at 80% load with the following initial steady-state lube oil and cooling water temperatures for the main turbine lube oil heat exchanger:

$$\begin{aligned}T_{\text{oil in}} &= 174^{\circ}\text{F} \\T_{\text{oil out}} &= 114^{\circ}\text{F} \\T_{\text{water in}} &= 85^{\circ}\text{F} \\T_{\text{water out}} &= 115^{\circ}\text{F}\end{aligned}$$

Six months later, the current steady-state heat exchanger temperatures are:

$$\begin{aligned}T_{\text{oil in}} &= 174^{\circ}\text{F} \\T_{\text{oil out}} &= 120^{\circ}\text{F} \\T_{\text{water in}} &= 85^{\circ}\text{F} \\T_{\text{water out}} &= 120^{\circ}\text{F}\end{aligned}$$

Assume that the lube oil mass flow rate does not change, and that the specific heat values for the cooling water and lube oil do not change. Also, assume that the main turbine lube oil system is a closed system.

The differences between the initial and current steady-state heat exchanger temperatures could be caused by the current main turbine-generator load being _____ with the current heat exchanger cooling water mass flow rate being _____.

- A. higher; lower
- B. higher; higher
- C. lower; lower
- D. lower; higher

ANSWER: C.

TOPIC: 291006
KNOWLEDGE: K1.07 [2.7/2.8]
QID: B5716 (P5716)

Refer to the drawing of an operating parallel-flow lube oil heat exchanger (see figure below). Assume that lube oil (LO) inlet temperature is greater than cooling water (CW) inlet temperature.

Unlike a counter-flow heat exchanger, in a parallel-flow heat exchanger the _____ temperature can never be greater than the _____ temperature.

- A. LO outlet; CW inlet
- B. LO outlet; CW outlet
- C. CW outlet; LO inlet
- D. CW outlet; LO outlet

ANSWER: D.

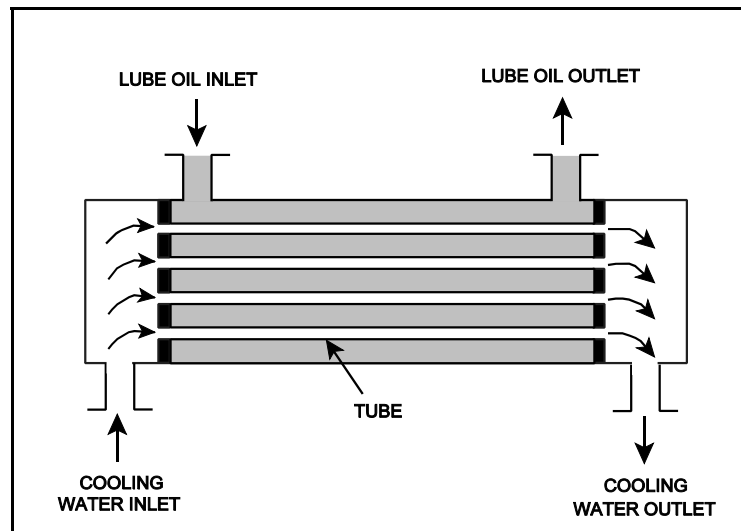

TOPIC: 291006
KNOWLEDGE: K1.08 [2.9/3.0]
QID: B331 (P534)

Refer to the drawing of an operating lube oil heat exchanger (see figure below).

Increasing the oil flow rate through the heat exchanger will cause the oil outlet temperature to _____ and the cooling water outlet temperature to _____.

- A. increase; increase
- B. increase; decrease
- C. decrease; increase
- D. decrease; decrease

ANSWER: A.

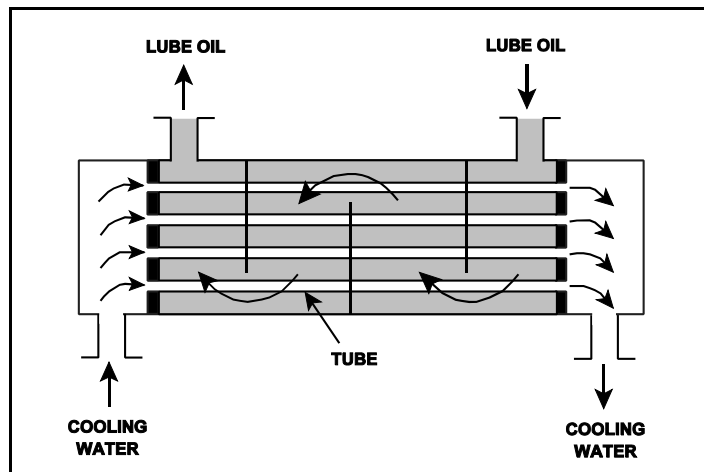

TOPIC: 291006
KNOWLEDGE: K1.08 [2.9/3.0]
QID: B431 (P632)

Refer to the drawing of an operating lube oil heat exchanger (see figure below).

Assume that the inlet lube oil and inlet cooling water temperatures are constant and cooling water flow rate remains the same. Decreasing the oil flow rate through the heat exchanger will cause the oil outlet temperature to _____ and the cooling water outlet temperature to _____.

- A. increase, increase
- B. increase, decrease
- C. decrease, increase
- D. decrease, decrease

ANSWER: D.

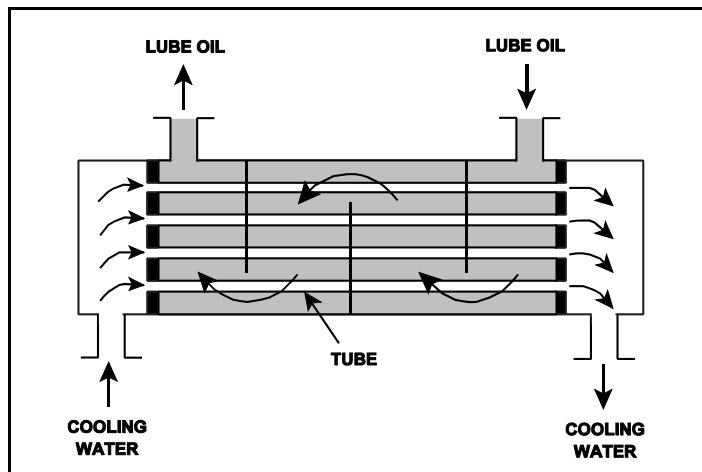

TOPIC: 291006
KNOWLEDGE: K1.08 [2.9/3.0]
QID: B834 (P2034)

Refer to the drawing of an operating lube oil heat exchanger (see figure below).

Given the following existing conditions:

$c_{p\text{-oil}}$ = 1.1 Btu/lbm-°F
 $c_{p\text{-water}}$ = 1.0 Btu/lbm-°F
 \dot{m}_{oil} = 1.8×10^4 lbm/hr
 \dot{m}_{water} = 1.65×10^4 lbm/hr
 $T_{\text{oil in}}$ = 170°F
 $T_{\text{oil out}}$ = 120°F
 $T_{\text{water out}}$ = 110°F
 $T_{\text{water in}}$ = ?

Which one of the following is the cooling water inlet temperature ($T_{\text{water in}}$) in this heat exchanger?

- A. 45°F
- B. 50°F
- C. 55°F
- D. 60°F

ANSWER: B.

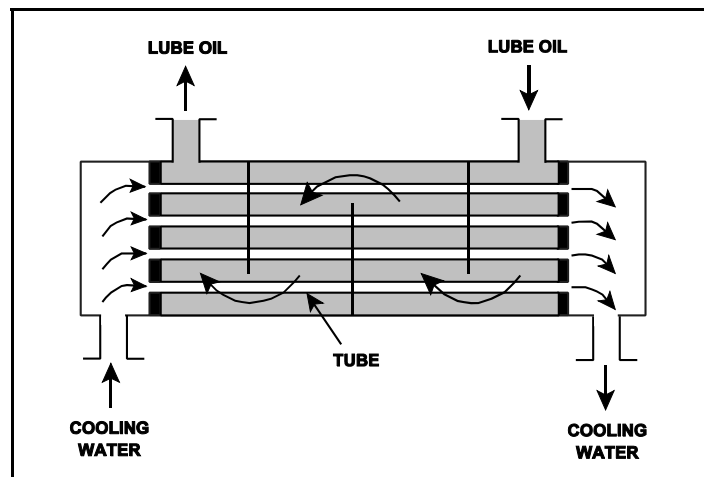

TOPIC: 291006
KNOWLEDGE: K1.08 [2.9/3.0]
QID: B934 (P3132)

Refer to the drawing of a lube oil heat exchanger (see figure below).

The heat exchanger is operating with the following parameters:

$$\begin{aligned}\dot{Q}_{\text{oil}} &= 1.0 \times 10^7 \text{ Btu/hr} \\ T_{\text{oil in}} &= 170^\circ\text{F} \\ T_{\text{oil out}} &= 134^\circ\text{F} \\ T_{\text{water in}} &= 85^\circ\text{F} \\ T_{\text{water out}} &= 112^\circ\text{F} \\ c_{p\text{-oil}} &= 1.1 \text{ Btu/lbm-}^\circ\text{F} \\ c_{p\text{-water}} &= 1.0 \text{ Btu/lbm-}^\circ\text{F} \\ \dot{m}_{\text{water}} &= ?\end{aligned}$$

Which one of the following is the mass flow rate of the cooling water?

- A. 4.5×10^5 lbm/hr
- B. 3.7×10^5 lbm/hr
- C. 2.5×10^5 lbm/hr
- D. 1.2×10^5 lbm/hr

ANSWER: B.

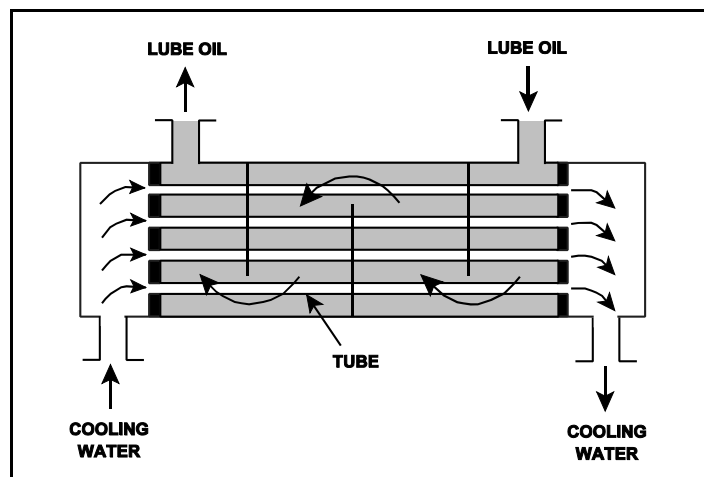

TOPIC: 291006
KNOWLEDGE: K1.08 [2.9/3.0]
QID: B1033

Refer to the drawing of an operating lube oil heat exchanger (see figure below).

Given the following existing conditions:

$c_{p\text{-oil}} = 1.1 \text{ Btu/lbm-}^\circ\text{F}$
 $c_{p\text{-water}} = 1.0 \text{ Btu/lbm-}^\circ\text{F}$
 $\dot{m}_{\text{oil}} = 1.8 \times 10^4 \text{ lbm/hr}$
 $\dot{m}_{\text{water}} = 1.65 \times 10^4 \text{ lbm/hr}$
 $T_{\text{oil in}} = 115^\circ\text{F}$
 $T_{\text{oil out}} = 90^\circ\text{F}$
 $T_{\text{water out}} = 110^\circ\text{F}$
 $T_{\text{water in}} = ?$

Which one of the following is the approximate cooling water inlet temperature ($T_{\text{water in}}$) for this heat exchanger?

- A. 50°F
- B. 60°F
- C. 75°F
- D. 80°F

ANSWER: D.

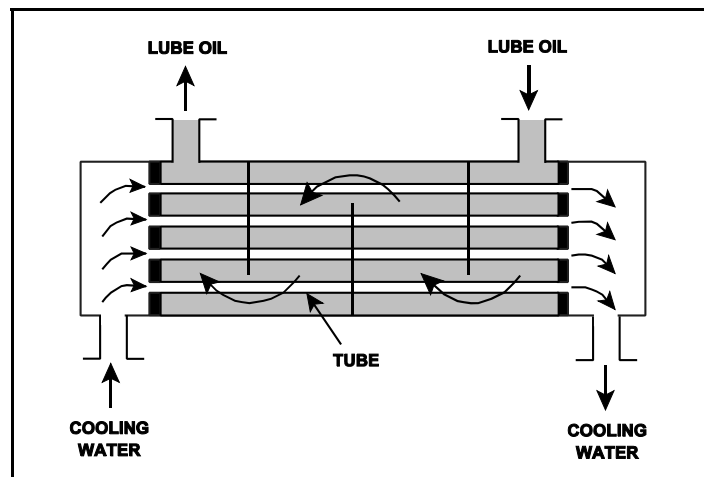

TOPIC: 291006
KNOWLEDGE: K1.08 [2.9/3.0]
QID: B1331

Refer to the drawing of an operating lube oil heat exchanger (see figure below).

Given the following existing conditions:

$$\begin{aligned}\dot{m}_{\text{oil}} &= 1.8 \times 10^4 \text{ lbm/hr} \\ \dot{m}_{\text{water}} &= 3.3 \times 10^4 \text{ lbm/hr} \\ c_{p\text{-oil}} &= 1.1 \text{ Btu/lbm-}^\circ\text{F} \\ c_{p\text{-water}} &= 1.0 \text{ Btu/lbm-}^\circ\text{F} \\ T_{\text{cw-in}} &= 90^\circ\text{F} \\ T_{\text{cw-out}} &= 120^\circ\text{F} \\ T_{\text{oil-in}} &= 170^\circ\text{F} \\ T_{\text{oil-out}} &= ?\end{aligned}$$

Which one of the following is the approximate temperature of the oil exiting the heat exchanger ($T_{\text{oil-out}}$)?

- A. 110°F
- B. 120°F
- C. 130°F
- D. 140°F

ANSWER: B.

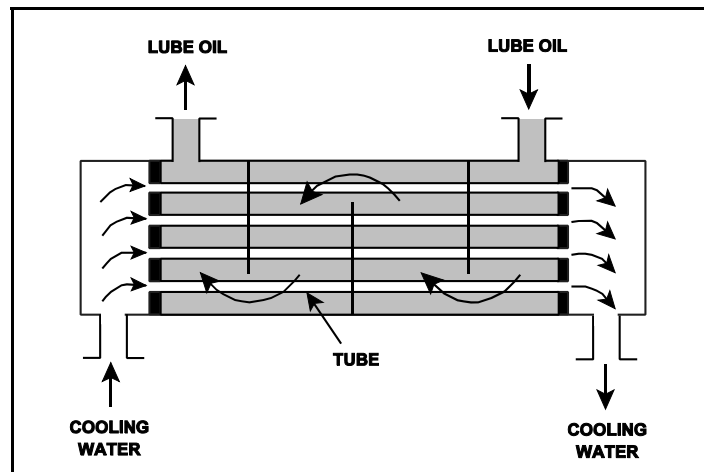

TOPIC: 291006
KNOWLEDGE: K1.08 [2.9/3.0]
QID: B1435 (P2232)

Refer to the drawing of an operating lube oil heat exchanger (see figure below).

Given the following existing conditions:

$\dot{m}_{oil} = 1.8 \times 10^4 \text{ lbm/hr}$
 $\dot{m}_{water} = 3.3 \times 10^4 \text{ lbm/hr}$
 $c_{p-oil} = 1.1 \text{ Btu/lbm-}^\circ\text{F}$
 $c_{p-water} = 1.0 \text{ Btu/lbm-}^\circ\text{F}$
 $T_{cw-in} = 90^\circ\text{F}$
 $T_{cw-out} = 120^\circ\text{F}$
 $T_{oil-in} = 170^\circ\text{F}$
 $T_{oil-out} = ?$

What is the approximate temperature of the oil exiting the heat exchanger ($T_{oil-out}$)?

- A. 110°F
- B. 120°F
- C. 130°F
- D. 140°F

ANSWER: B.

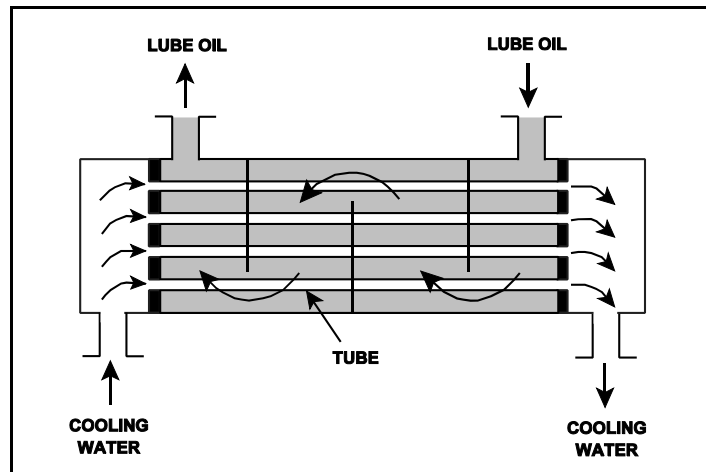

TOPIC: 291006
KNOWLEDGE: K1.08 [2.9/3.0]
QID: B1531 (P1533)

Refer to the drawing of an operating lube oil heat exchanger (see figure below).

Given the following existing conditions:

$\dot{m}_{oil} = 1.8 \times 10^4 \text{ lbm/hr}$
 $\dot{m}_{water} = 3.3 \times 10^4 \text{ lbm/hr}$
 $c_{p-oil} = 1.1 \text{ Btu/lbm-}^\circ\text{F}$
 $c_{p-water} = 1.0 \text{ Btu/lbm-}^\circ\text{F}$
 $T_{cw-in} = 90^\circ\text{F}$
 $T_{cw-out} = 120^\circ\text{F}$
 $T_{oil-in} = 170^\circ\text{F}$
 $T_{oil-out} = ?$

What is the approximate temperature of the oil exiting the heat exchanger ($T_{oil-out}$)?

- A. 110°F
- B. 120°F
- C. 130°F
- D. 140°F

ANSWER: B.

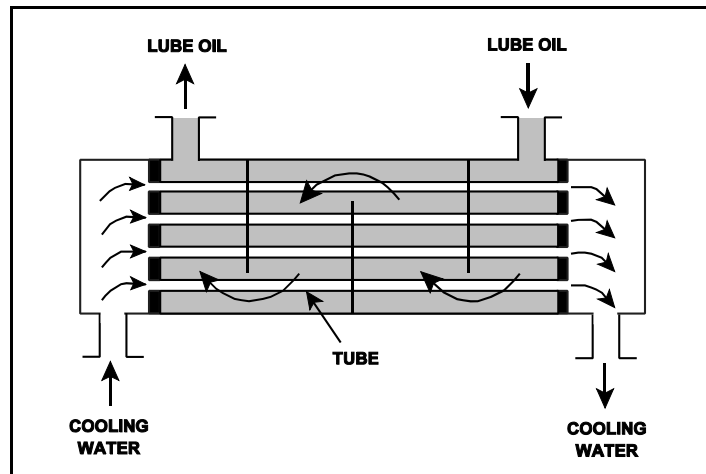

TOPIC: 291006
KNOWLEDGE: K1.08 [2.9/3.0]
QID: B1631 (P1634)

Refer to the drawing of an operating lube oil heat exchanger (see figure below).

Given the following information, which one of the following is the temperature of the oil exiting the heat exchanger ($T_{\text{oil-out}}$)?

$$\begin{aligned}\dot{m}_{\text{oil}} &= 2.0 \times 10^4 \text{ lbm/hr} \\ \dot{m}_{\text{water}} &= 3.0 \times 10^4 \text{ lbm/hr} \\ c_{p\text{-oil}} &= 1.1 \text{ Btu/lbm-}^\circ\text{F} \\ c_{p\text{-water}} &= 1.0 \text{ Btu/lbm-}^\circ\text{F} \\ T_{\text{cw-in}} &= 92^\circ\text{F} \\ T_{\text{cw-out}} &= 125^\circ\text{F} \\ T_{\text{oil-in}} &= 180^\circ\text{F} \\ T_{\text{oil-out}} &= ?\end{aligned}$$

- A. 126°F
- B. 135°F
- C. 147°F
- D. 150°F

ANSWER: B.

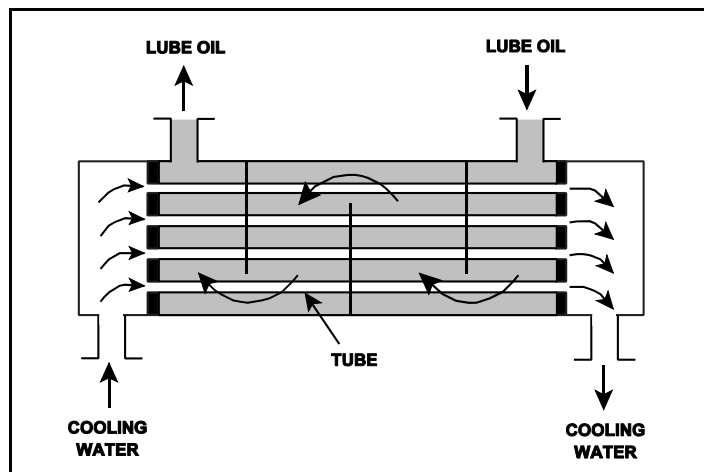

TOPIC: 291006
KNOWLEDGE: K1.08 [2.9/3.0]
QID: B1933 (P1934)

Refer to the drawing of an operating lube oil heat exchanger (see figure below).

Given the following information, which one of the following is the temperature of the oil exiting the heat exchanger ($T_{\text{oil-out}}$)?

$$\begin{aligned}\dot{m}_{\text{oil}} &= 1.5 \times 10^4 \text{ lbm/hr} \\ \dot{m}_{\text{water}} &= 2.5 \times 10^4 \text{ lbm/hr} \\ c_{p\text{-oil}} &= 1.1 \text{ Btu/lbm-}^\circ\text{F} \\ c_{p\text{-water}} &= 1.0 \text{ Btu/lbm-}^\circ\text{F} \\ T_{\text{cw-in}} &= 92^\circ\text{F} \\ T_{\text{cw-out}} &= 125^\circ\text{F} \\ T_{\text{oil-in}} &= 160^\circ\text{F} \\ T_{\text{oil-out}} &= ?\end{aligned}$$

- A. 110°F
- B. 127°F
- C. 135°F
- D. 147°F

ANSWER: A.

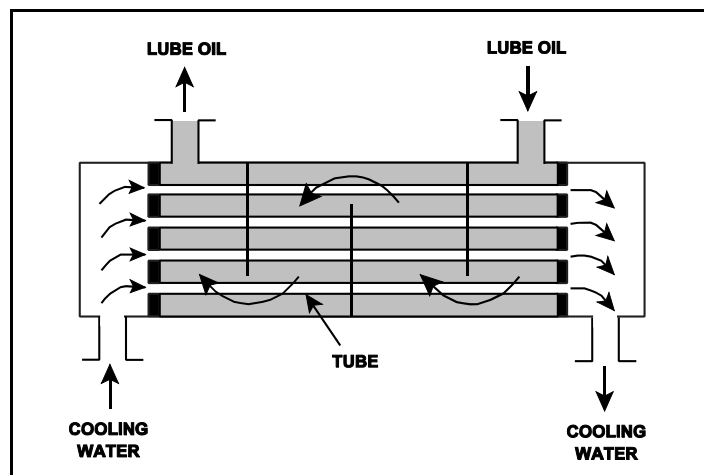

TOPIC: 291006
KNOWLEDGE: K1.08 [2.9/3.0]
QID: B2132 (P2133)

Refer to the drawing of a lube oil heat exchanger (see figure below).

The lube oil heat exchanger is in service with the following inlet temperatures:

Lube oil inlet temperature: 120°F
Cooling water inlet temperature: 60°F

Assuming cooling water flow rate is greater than lube oil flow rate, which one of the following sets of heat exchanger outlet temperatures is possible? (Neglect any difference between fluid-specific heats.)

- | <u>Lube Oil
Outlet Temp</u> | <u>Cooling Water
Outlet Temp</u> |
|---------------------------------|--------------------------------------|
| A. 100°F | 100°F |
| B. 90°F | 90°F |
| C. 80°F | 80°F |
| D. 80°F | 100°F |

ANSWER: C.

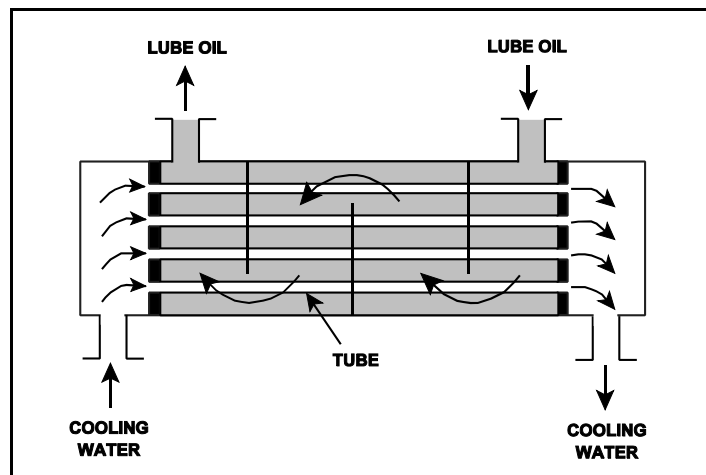

TOPIC: 291006
KNOWLEDGE: K1.08 [2.9/3.0]
QID: B2233 (P2434)

Refer to the drawing of a lube oil heat exchanger (see figure below).

The lube oil heat exchanger is in service with the following inlet temperatures:

Lube oil inlet temperature: 130°F
Cooling water inlet temperature: 70°F

Assuming cooling water flow rate is greater than lube oil flow rate, which one of the following sets of heat exchanger outlet temperatures is possible? (Assume both fluids have the same c_p .)

	<u>Lube Oil Outlet Temp</u>	<u>Cooling Water Outlet Temp</u>
A.	90°F	100°F
B.	90°F	110°F
C.	100°F	100°F
D.	100°F	110°F

ANSWER: A.

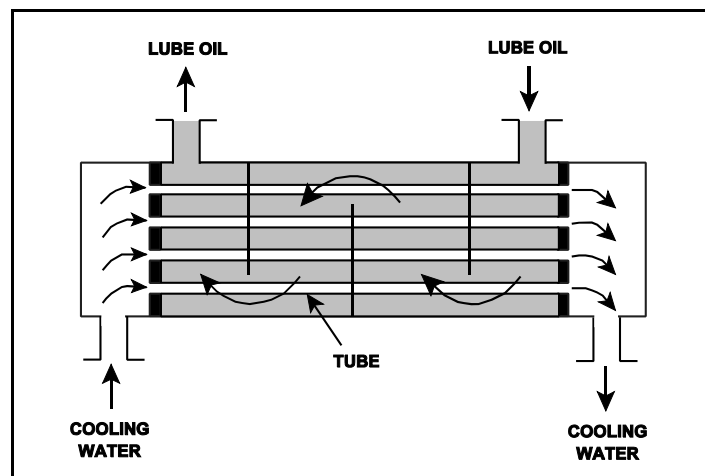

TOPIC: 291006
KNOWLEDGE: K1.08 [2.9/3.0]
QID: B2534 (P2532)

Refer to the drawing of an operating lube oil heat exchanger (see figure below).

Given the following information, which one of the following is the temperature of the cooling water exiting the heat exchanger (T_{cw-out})?

$$\begin{aligned}\dot{m}_{oil} &= 1.5 \times 10^4 \text{ lbm/hr} \\ \dot{m}_{water} &= 2.5 \times 10^4 \text{ lbm/hr} \\ c_{p-oil} &= 1.1 \text{ Btu/lbm-}^\circ\text{F} \\ c_{p-water} &= 1.0 \text{ Btu/lbm-}^\circ\text{F} \\ T_{oil-in} &= 160^\circ\text{F} \\ T_{oil-out} &= 110^\circ\text{F} \\ T_{cw-in} &= 92^\circ\text{F} \\ T_{cw-out} &= ?\end{aligned}$$

- A. 110°F
- B. 115°F
- C. 120°F
- D. 125°F

ANSWER: D.

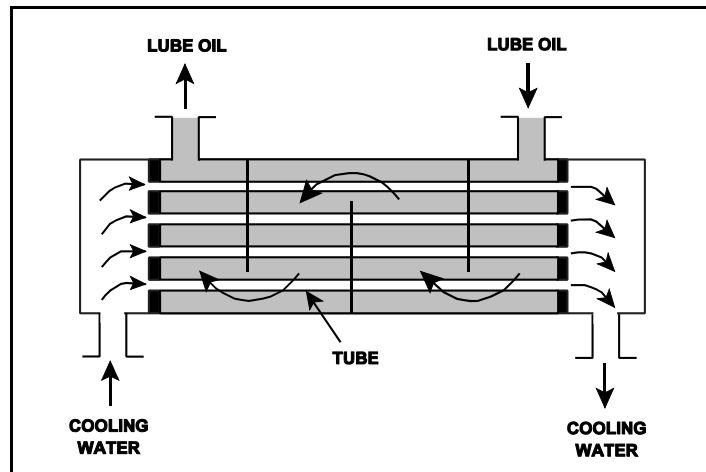

TOPIC: 291006
KNOWLEDGE: K1.08 [2.9/3.0]
QID: B2632 (P2633)

Refer to the drawing of a lube oil heat exchanger (see figure below).

The lube oil heat exchanger is in service with the following inlet temperatures:

Lube oil inlet temperature: 110°F
Cooling water inlet temperature: 75°F

Assuming cooling water flow rate is greater than lube oil flow rate, which one of the following sets of heat exchanger outlet temperatures is possible? (Neglect any difference between fluid specific heats.)

- | | <u>Lube Oil
Outlet Temp</u> | <u>Cooling Water
Outlet Temp</u> |
|----|---------------------------------|--------------------------------------|
| A. | 100°F | 100°F |
| B. | 100°F | 90°F |
| C. | 90°F | 100°F |
| D. | 90°F | 90°F |

ANSWER: D.

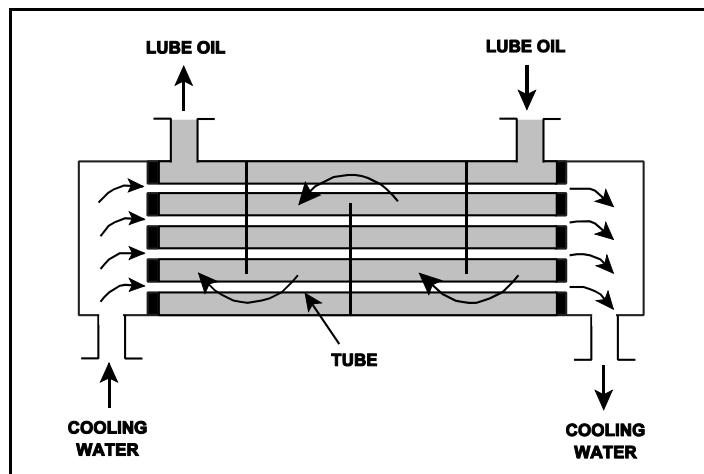

TOPIC: 291006
KNOWLEDGE: K1.08 [2.9/3.0]
QID: B2733 (P2733)

Refer to the drawing of a lube oil heat exchanger (see figure below).

The lube oil heat exchanger is in service with the following inlet temperatures:

Lube oil inlet temperature: 130°F
Cooling water inlet temperature: 70°F

Assuming cooling water flow rate is greater than lube oil flow rate, which one of the following pairs of heat exchanger outlet temperatures is not possible? (Assume both fluids have the same specific heat.)

- | | <u>Lube Oil
Outlet Temp</u> | <u>Cooling Water
Outlet Temp</u> |
|----|---------------------------------|--------------------------------------|
| A. | 90°F | 86°F |
| B. | 100°F | 85°F |
| C. | 110°F | 84°F |
| D. | 120°F | 83°F |

ANSWER: D.

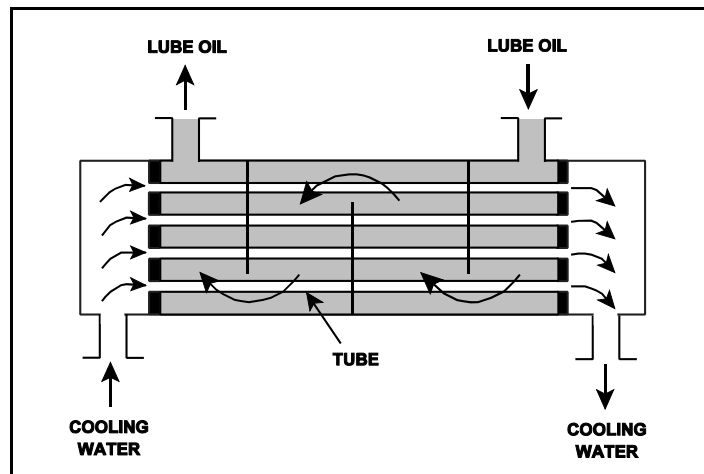

TOPIC: 291006
KNOWLEDGE: K1.08 [2.9/3.0]
QID: B2832

Refer to the drawing of an operating lube oil heat exchanger (see figure below).

Given the following initial parameters:

Cooling water inlet temperature (T_{cw-in}) = 75°F
Cooling water outlet temperature (T_{cw-out}) = 105°F
Oil inlet temperature (T_{oil-in}) = 140°F
Oil outlet temperature ($T_{oil-out}$) = 100°F

Air introduction to the heat exchanger results in some of the heat exchanger tubes becoming uncovered. As a result, T_{cw-out} decreases to 99°F. Assume that the mass flow rate and specific heat of both fluids remain the same, and that T_{oil-in} does not change. Which one of the following will be the approximate temperature of the oil exiting the heat exchanger ($T_{oil-out}$)?

- A. 99°F
- B. 108°F
- C. 116°F
- D. 122°F

ANSWER: B.

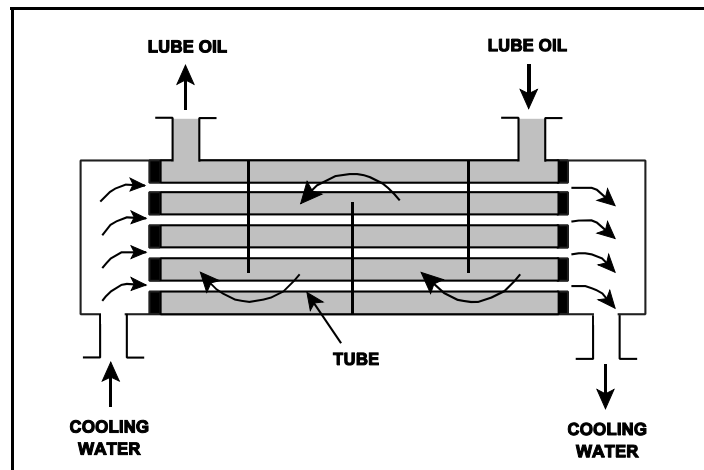

TOPIC: 291006
KNOWLEDGE: K1.08 [2.9/3.0]
QID: B2933 (P2934)

Refer to the drawing of a lube oil heat exchanger (see figure below).

The lube oil heat exchanger is in service with the following inlet temperatures:

Lube oil inlet temperature: 130°F
Cooling water inlet temperature: 70°F

Assuming the cooling water flow rate exceeds the lube oil flow rate, which one of the following pairs of heat exchanger outlet temperatures is possible? (Assume both fluids have the same specific heat.)

- | | <u>Lube Oil
Outlet Temp</u> | <u>Cooling Water
Outlet Temp</u> |
|----|---------------------------------|--------------------------------------|
| A. | 100°F | 90°F |
| B. | 100°F | 100°F |
| C. | 110°F | 90°F |
| D. | 110°F | 100°F |

ANSWER: A.

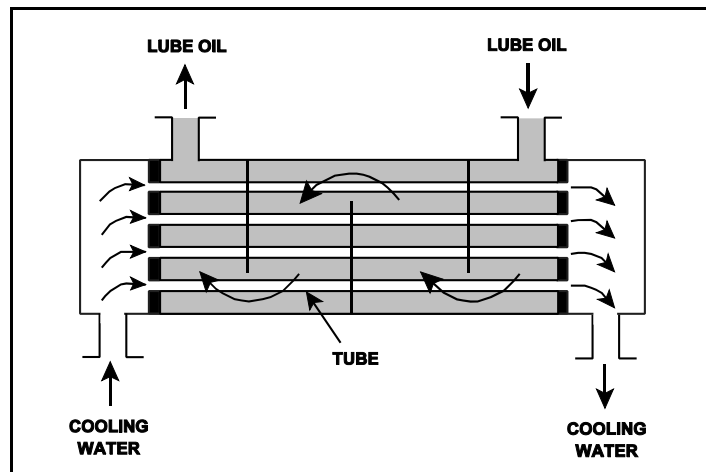

TOPIC: 291006
KNOWLEDGE: K1.08 [2.9/3.0]
QID: B3032 (P3081)

The volumetric flow rate of cooling water entering a heat exchanger is 500 gpm.

Given the following:

Cooling water pressure entering and leaving the heat exchanger is 10 psig.

Cooling water inlet temperature is 90°F.

Cooling water outlet temperature is 160°F.

Heat exchanger inlet and outlet piping have the same diameter.

What is the approximate volumetric flow rate of the cooling water exiting the heat exchanger?

- A. 496 gpm
- B. 500 gpm
- C. 504 gpm
- D. 509 gpm

ANSWER: D.

TOPIC: 291006
KNOWLEDGE: K1.08 [2.9/3.0]
QID: B3431

Refer to the drawing of a lube oil heat exchanger (see figure below).

The heat exchanger is operating with the following parameters:

$c_{p\text{-oil}}$ = 1.1 Btu/lbm-°F
 $c_{p\text{-water}}$ = 1.0 Btu/lbm-°F
 $T_{\text{oil in}}$ = 174°F
 $T_{\text{oil out}}$ = 114°F
 $T_{\text{water in}}$ = 85°F
 $T_{\text{water out}}$ = 121°F
 \dot{m}_{oil} = 4.0×10^4 lbm/hr
 \dot{m}_{water} = ?

What is the mass flow rate of the cooling water?

- A. 8.0×10^4 lbm/hr
- B. 7.3×10^4 lbm/hr
- C. 2.6×10^4 lbm/hr
- D. 2.2×10^4 lbm/hr

ANSWER: B.

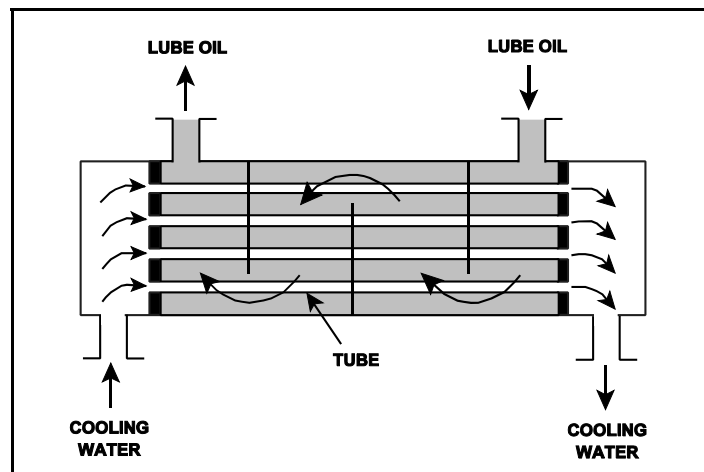

TOPIC: 291006
 KNOWLEDGE: K1.08 [2.9/3.0]
 QID: B3732 (P3732)

Refer to the drawing of a lube oil heat exchanger (see figure below).

The lube oil heat exchanger is in service with the following inlet temperatures:

Lube oil inlet temperature: 130°F
 Cooling water inlet temperature: 70°F

Assume that cooling water mass flow rate is less than lube oil mass flow rate, and that both fluids have the same specific heat. Which one of the following pairs of heat exchanger outlet temperatures is not possible?

- | | <u>Lube Oil
Outlet Temp</u> | <u>Cooling Water
Outlet Temp</u> | |
|----|---------------------------------|--------------------------------------|--|
| A. | 100°F | 105°F | |
| B. | 105°F | 105°F | |
| C. | 110°F | 90°F | |
| D. | 115°F | 90°F | |

ANSWER: C.

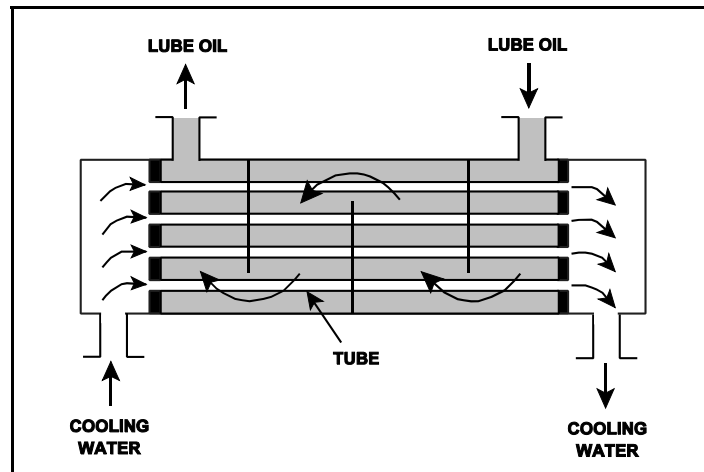

TOPIC: 291006
KNOWLEDGE: K1.08 [2.9/3.0]
QID: B3733 (P3783)

A condensate pump is taking suction on a main condenser hotwell, containing water at 100°F, and discharging the water at a volumetric flow rate of 100,000 gpm to the main feedwater system. The main feedwater system heats the water to 400°F before it enters the reactor vessel. Assume there is no leakage, and no bypass or recirculation flow paths are in use.

What is the approximate volumetric flow rate of the feedwater entering the reactor vessel?

- A. 100,000 gpm
- B. 105,000 gpm
- C. 109,000 gpm
- D. 115,000 gpm

ANSWER: D.

TOPIC: 291006
KNOWLEDGE: K1.08 [2.9/3.0]
QID: B4416 (P4416)

Refer to the drawing of a lube oil heat exchanger (see figure below).

The lube oil heat exchanger is in service with the following inlet temperatures:

Lube oil inlet temperature: 120°F
Cooling water inlet temperature: 60°F

Assuming cooling water flow rate is greater than lube oil flow rate, which one of the following sets of heat exchanger outlet temperatures is possible? (Neglect any difference between fluid specific heats.)

- | | <u>Lube Oil
Outlet Temp</u> | <u>Cooling Water
Outlet Temp</u> |
|----|---------------------------------|--------------------------------------|
| A. | 90°F | 100°F |
| B. | 90°F | 85°F |
| C. | 95°F | 100°F |
| D. | 95°F | 85°F |

ANSWER: B.

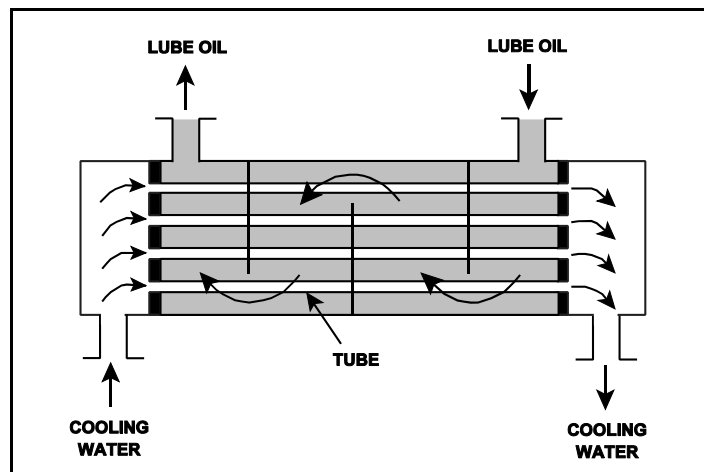

TOPIC: 291006
KNOWLEDGE: K1.08 [2.9/3.0]
QID: B5517 (P5516)

Refer to the drawing of a lube oil heat exchanger (see figure below).

The lube oil heat exchanger is in service with the following inlet temperatures:

Lube oil inlet temperature: 130°F
Cooling water inlet temperature: 70°F

Given that cooling water mass flow rate is greater than lube oil mass flow rate, which one of the following pairs of heat exchanger outlet temperatures is not possible? (Neglect any difference between the fluid specific heat capacities.)

- | | <u>Lube Oil</u>
<u>Outlet Temp</u> | <u>Cooling Water</u>
<u>Outlet Temp</u> |
|----|---------------------------------------|--------------------------------------------|
| A. | 90°F | 105°F |
| B. | 90°F | 100°F |
| C. | 110°F | 95°F |
| D. | 110°F | 85°F |

ANSWER: C.

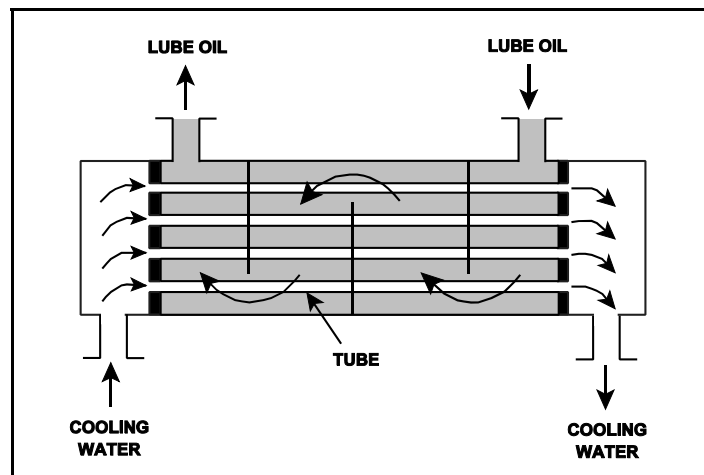

TOPIC: 291006
KNOWLEDGE: K1.08 [2.9/3.0]
QID: B5617 (P5616)

Refer to the drawing of an operating lube oil heat exchanger (see figure below).

Assume that the inlet lube oil and inlet cooling water temperatures are constant and the lube oil flow rate remains the same. If the cooling water flow rate increases, the lube oil outlet temperature will _____ and the cooling water outlet temperature will _____.

- A. increase, increase
- B. increase, decrease
- C. decrease, increase
- D. decrease, decrease

ANSWER: D.

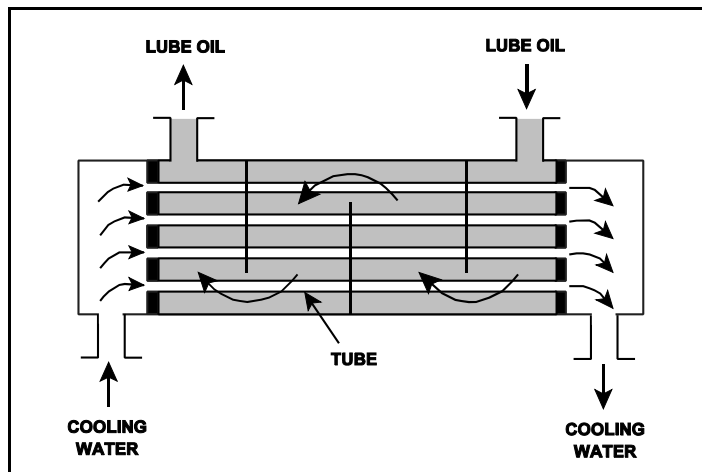

TOPIC: 291006
KNOWLEDGE: K1.09 [2.7/2.8]
QID: B232

A reactor is shut down with a reactor coolant temperature of 400°F and all control rods fully inserted. What is the major adverse consequence resulting from rapidly reducing the reactor coolant temperature to 250°F?

- A. Excessive stress in the ceramic fuel pellets of the reactor core
- B. Excessive stress on the reactor vessel wall
- C. Uncontrolled reactor criticality
- D. Loss of core inlet subcooling

ANSWER: B.

TOPIC: 291006
KNOWLEDGE: K1.09 [2.7/2.8]
QID: B633 (P2832)

Steam has been admitted to a main condenser for 25 minutes with no cooling water. Initiating full cooling water flow rate at this time will...

- A. reduce the stress on the condenser shell by rapidly cooling the shell.
- B. reduce the stress on the condenser tubes by rapidly cooling the tubes.
- C. induce large thermal stresses on the condenser shell.
- D. induce large thermal stresses on the junctions between the condenser tubes and the tubesheet.

ANSWER: D.

TOPIC: 291006
KNOWLEDGE: K1.10 [2.8/2.8]
QID: B32

A nuclear power plant is operating at full power with 2°F of condensate subcooling. Which one of the following changes will decrease subcooling of the condensate entering the main condenser hot well? (Assume condensate temperature does not change.)

- A. Decreased circulating water flow rate
- B. Increased gas buildup in the main condenser
- C. Decreased main condenser hotwell level
- D. Decreased main turbine steam flow

ANSWER: D.

TOPIC: 291006
KNOWLEDGE: K1.10 [2.8/2.8]
QID: B111 (P1834)

During normal reactor operation, a main condenser develops an air leak which decreases vacuum at a rate of 1 inch Hg/min. Which one of the following would increase because of this condition?

- A. Extraction steam flow rate
- B. Condenser hotwell temperature
- C. Low pressure turbine exhaust steam moisture content
- D. Steam cycle efficiency

ANSWER: B.

TOPIC: 291006
KNOWLEDGE: K1.10 [2.8/2.8]
QID: B733

Which one of the following changes will result in increased subcooling of the condensate water in the condenser hot well?

- A. Decrease circulating water flow.
- B. Increase circulating water temperature.
- C. Decrease the main turbine generator MW load.
- D. Isolate one bay of the condenser circulating water system.

ANSWER: C.

TOPIC: 291006
KNOWLEDGE: K1.10 [2.8/2.8]
QID: B1232

Assuming that condenser cooling water inlet temperature and flow rate do not change, if condenser vacuum improves, condensate temperature will...

- A. increase because condensate subcooling has decreased.
- B. increase because condenser saturation pressure has increased.
- C. decrease because condensate subcooling has increased.
- D. decrease because condenser saturation pressure has decreased.

ANSWER: D.

TOPIC: 291006
KNOWLEDGE: K1.10 [2.8/2.8]
QID: B2133

During normal plant operation at 100% power, a main condenser develops an air leak that degrades vacuum at a rate of 1 inch Hg/min. Assuming the plant continues to operate at 100% power, condenser hotwell temperature will...

- A. increase because condensation of turbine exhaust steam is occurring at a higher temperature.
- B. increase because more work is being extracted from the steam by the turbine.
- C. decrease because condensation of turbine exhaust steam is occurring at a lower temperature.
- D. decrease because less work is being extracted from the steam by the turbine.

ANSWER: A.

TOPIC: 291006
KNOWLEDGE: K1.10 [2.8/2.8]
QID: B2633 (P2634)

A nuclear power plant is operating at steady-state 100% power. Assuming that condenser cooling water inlet temperature and flow rate do not change, if condenser vacuum decreases, condensate temperature will...

- A. increase because condensate subcooling has decreased.
- B. increase because condenser saturation pressure has increased.
- C. decrease because condensate subcooling has increased.
- D. decrease because condenser saturation pressure has decreased.

ANSWER: B.

TOPIC: 291006
KNOWLEDGE: K1.10 [2.8/2.8]
QID: B2736 (P3534)

A nuclear power plant is operating at steady-state 100% power when air inleakage causes main condenser vacuum to decrease from 28 inches Hg to 27 inches Hg. Assume the steam inlet quality and mass flow rate of steam through the main turbine remain unchanged, and that condenser cooling water inlet temperature and flow rate do not change.

When the plant stabilizes, turbine exhaust quality will be _____ and turbine exhaust temperature will be _____.

- A. higher; higher
- B. higher; lower
- C. lower; higher
- D. lower; lower

ANSWER: A.

TOPIC: 291006
KNOWLEDGE: K1.11 [2.8/2.8]
QID: B374

A pressure gauge on a condenser reads 27 inches of mercury (Hg) vacuum. What is the absolute pressure corresponding to this vacuum? (Assume that standard atmospheric pressure equals 15 psia.)

- A. 1.0 psia
- B. 1.5 psia
- C. 13.5 psia
- D. 14.0 psia

ANSWER: B.

TOPIC: 291006
KNOWLEDGE: K1.11 [2.8/2.8]
QID: B434

A steam-driven turbine exhausts to a condenser. As condenser vacuum is increased, the turbine backpressure will _____ and the turbine power output will _____.

- A. increase; increase
- B. increase; decrease
- C. decrease; increase
- D. decrease; decrease

ANSWER: C.

TOPIC: 291006
KNOWLEDGE: K1.11 [2.8/2.8]
QID: B835

A pressure gauge on a main condenser reads 2 psiv. What is the approximate absolute pressure in the main condenser?

- A. 2 psia
- B. 13 psia
- C. 15 psia
- D. 17 psia

ANSWER: B.

TOPIC: 291006
KNOWLEDGE: K1.11 [2.8/2.8]
QID: B1035

A condenser absolute pressure of 4 inches Hg is equivalent to...

- A. 11 inches Hg vacuum.
- B. 13 inches Hg vacuum.
- C. 26 inches Hg vacuum.
- D. 28 inches Hg vacuum.

ANSWER: C.

TOPIC: 291006
KNOWLEDGE: K1.11 [2.8/2.8]
QID: B1633

Which one of the following is the approximate condenser vacuum when condenser pressure is 7 inches Hg absolute?

- A. 0 inches Hg vacuum
- B. 7 inches Hg vacuum
- C. 23 inches Hg vacuum
- D. 30 inches Hg vacuum

ANSWER: C.

TOPIC: 291006
KNOWLEDGE: K1.11 [2.8/2.8]
QID: B2131

Which one of the following is the approximate condenser vacuum (inches Hg vacuum) when condenser pressure is 16 inches Hg absolute?

- A. 4 inches Hg vacuum
- B. 8 inches Hg vacuum
- C. 12 inches Hg vacuum
- D. 14 inches Hg vacuum

ANSWER: D.

TOPIC: 291006
KNOWLEDGE: K1.12 [2.9/3.0]
QID: B1133

A nuclear reactor is shut down at 400 psia during a maintenance outage when all forced core coolant flow is lost. Which one of the following will enhance natural circulation within the reactor vessel?

- A. Increasing reactor vessel pressure to 500 psia.
- B. Increasing reactor vessel water level above the steam separators.
- C. Decreasing reactor vessel pressure to 300 psia.
- D. Decreasing reactor vessel water level to just above the top of the core.

ANSWER: B.

TOPIC: 291006
KNOWLEDGE: K1.13 [2.7/2.9]
QID: B34

What is the saturation temperature for a boiling water reactor operating at 920 psig?

- A. 532.6°F
- B. 533.9°F
- C. 536.5°F
- D. 538.4°F

ANSWER: C.

TOPIC: 291006
KNOWLEDGE: K1.13 [2.7/2.9]
QID: B534

Which one of the following is the state of water at 20 psia and 250°F?

- A. Subcooled liquid
- B. Saturated liquid
- C. Mixture of saturated liquid and vapor
- D. Superheated vapor

ANSWER: D.

TOPIC: 291006
KNOWLEDGE: K1.13 [2.7/2.9]
QID: B1335

Which one of the following describes the state of water at 35 psia and 240°F?

- A. Subcooled liquid
- B. Saturated liquid
- C. Mixture of saturated liquid and vapor
- D. Superheated vapor

ANSWER: A.

TOPIC: 291006
KNOWLEDGE: K1.13 [2.7/2.9]
QID: B1433

Which one of the following is the state of water at 120 psig and 340°F?

- A. Subcooled liquid
- B. Saturated liquid
- C. Mixture of saturated liquid and saturated vapor
- D. Superheated vapor

ANSWER: A.

TOPIC: 291006
KNOWLEDGE: K1.13 [2.7/2.9]
QID: B1536

Which one of the following describes the state of water at 160 psig and 366°F?

- A. Saturated liquid
- B. Subcooled liquid
- C. Superheated vapor
- D. Mixture of saturated liquid and vapor

ANSWER: B.

TOPIC: 291006
KNOWLEDGE: K1.13 [2.7/2.9]
QID: B2336

Which one of the following describes the state of water at 160 psig and 372°F?

- A. Saturated liquid
- B. Subcooled liquid
- C. Superheated vapor
- D. Mixture of saturated liquid and vapor

ANSWER: C.

TOPIC: 291006
KNOWLEDGE: K1.13 [2.7/2.9]
QID: B2834

Which one of the following describes the state of water at 150 psig and 360°F?

- A. Saturated liquid
- B. Subcooled liquid
- C. Superheated vapor
- D. Mixture of saturated liquid and vapor

ANSWER: B.

TOPIC: 291006
KNOWLEDGE: K1.14 [3.1/3.2]
QID: B535

What is the reason for ensuring that a piping system is completely filled and vented prior to initiating system flow?

- A. To minimize the system head losses
- B. To ensure all noncondensable gases are removed from the piping system to reduce system corrosion
- C. To preclude a reduction in the overall system heat transfer coefficient
- D. To minimize the potential for water hammer

ANSWER: D.

TOPIC: 291006
KNOWLEDGE: K1.14 [3.1/3.2]
QID: B635

The discharge valve for a large operating centrifugal pump should be positioned slowly to minimize the...

- A. change in available net positive suction head.
- B. potential for causing water hammer.
- C. differential pressure stress exerted on the valve disk and stem.
- D. mechanical wear on the valve seat and stem packing.

ANSWER: B.

TOPIC: 291006
KNOWLEDGE: K1.14 [3.1/3.2]
QID: B1135

After starting a large motor-driven centrifugal cooling water pump, the pump discharge valve should be opened slowly to minimize the...

- A. potential for a water hammer.
- B. potential for pump cavitation.
- C. motor running current requirements.
- D. net positive suction head requirements.

ANSWER: A.

TOPIC: 291006
KNOWLEDGE: K1.15 [2.6/2.8]
QID: B3635 (P3633)

A main turbine-generator is operating at 80% load with the following initial steady-state temperatures for the main turbine lube oil heat exchanger:

$$\begin{aligned}T_{\text{oil in}} &= 174^{\circ}\text{F} \\T_{\text{oil out}} &= 114^{\circ}\text{F} \\T_{\text{water in}} &= 85^{\circ}\text{F} \\T_{\text{water out}} &= 115^{\circ}\text{F}\end{aligned}$$

After six months of main turbine-generator operation, the following final steady-state lube oil heat exchanger temperatures are observed:

$$\begin{aligned}T_{\text{oil in}} &= 179^{\circ}\text{F} \\T_{\text{oil out}} &= 119^{\circ}\text{F} \\T_{\text{water in}} &= 85^{\circ}\text{F} \\T_{\text{water out}} &= 115^{\circ}\text{F}\end{aligned}$$

Assume that the final cooling water and lube oil flow rates are the same as the initial flow rates, and that the specific heat values for the cooling water and lube oil do not change.

Which one of the following could be responsible for the differences between the initial and final heat exchanger steady-state temperatures?

- A. The heat exchanger tubes have become fouled with scale.
- B. The temperature of the cooling water source has increased.
- C. The final main turbine-generator load is higher than the initial load.
- D. The final main turbine-generator load is lower than the initial load.

ANSWER: A.

TOPIC: 291006
KNOWLEDGE: K1.15 [2.6/2.8]
QID: B4616 (P4617)

Refer to the drawing of two system curves for a typical main condenser cooling water system (see figure below).

Which one of the following will cause the system curve to shift from the solid curve toward the dashed curve?

- A. The main condenser tubes are cleaned.
- B. The main condenser tubes become increasingly fouled.
- C. Cooling water flow rate is increased by 25% by starting an additional cooling water pump.
- D. Cooling water flow rate is decreased by 25% by stopping one of the operating cooling water pumps.

ANSWER: A.

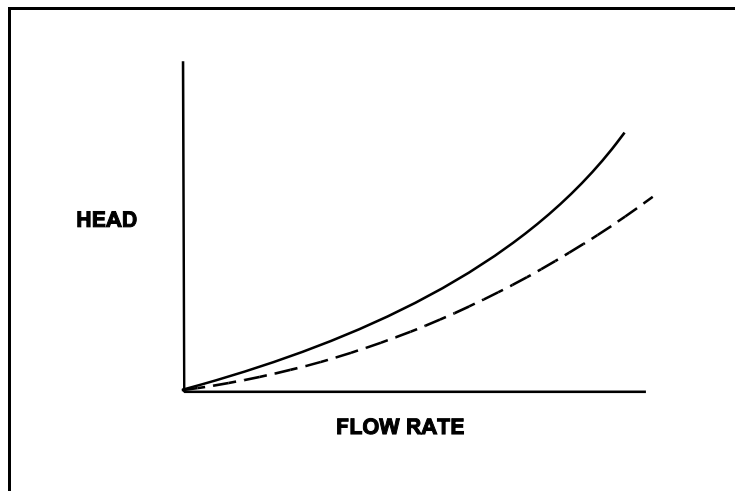

TOPIC: 291006
KNOWLEDGE: K1.15 [2.6/2.8]
QID: B5117 (P5116)

Refer to the drawing of two system curves for a typical main condenser cooling water system (see figure below).

Which one of the following will cause the system curve to shift from the solid curve toward the dashed curve?

- A. The main condenser tubes are cleaned.
- B. The main condenser tubes become increasingly fouled.
- C. Cooling water system flow rate is increased by 25% by starting an additional cooling water pump.
- D. Cooling water system flow rate is decreased by 25% by stopping one of the operating cooling water pumps.

ANSWER: B.

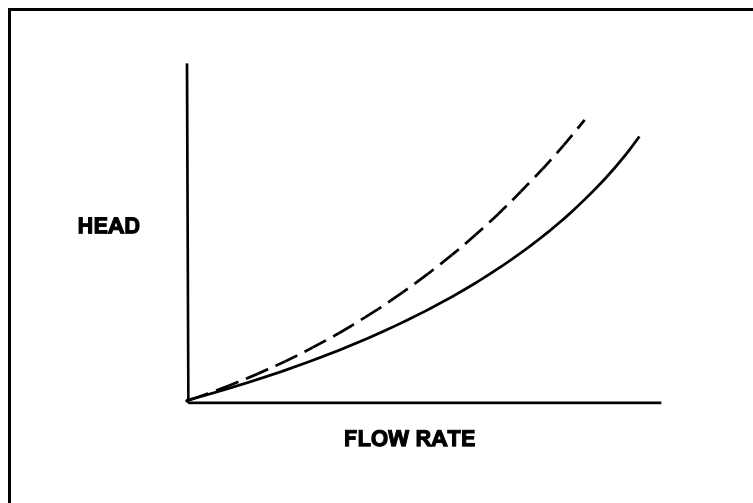

TOPIC: 291006
KNOWLEDGE: K1.16 [2.5/2.6]
QID: B156

The buildup of scale on heat-transfer surfaces in the reactor vessel...

- A. results in lower fuel temperature, which decreases the nuclear fuel cycle efficiency.
- B. is controlled by complying with core thermal limits and adhering to fuel preconditioning requirements.
- C. is controlled by using reactor water cleanup system and condensate system demineralizers.
- D. results in higher coolant temperature, which increases overall plant efficiency.

ANSWER: C.

TOPIC: 291006
KNOWLEDGE: K1.16 [2.5/2.6]
QID: B1136

Tube scaling in a parallel flow heat exchanger causes heat transfer rate to decrease because the...

- A. surface area of the tubes decreases.
- B. cooling fluid outlet temperature decreases.
- C. thermal conductivity of the scale is very low.
- D. flow through the heat exchanger becomes more turbulent.

ANSWER: C.

TOPIC: 291006
KNOWLEDGE: K1.16 [2.5/2.6]
QID: B1234 (P32)

Refer to the drawing of an operating lube oil heat exchanger (see figure below).

If scaling occurs inside the cooling water tubes, cooling water outlet temperature will _____ and lube oil outlet temperature will _____. (Assume oil and cooling water flow rates remain the same.)

- A. decrease; decrease
- B. decrease; increase
- C. increase; decrease
- D. increase; increase

ANSWER: B.

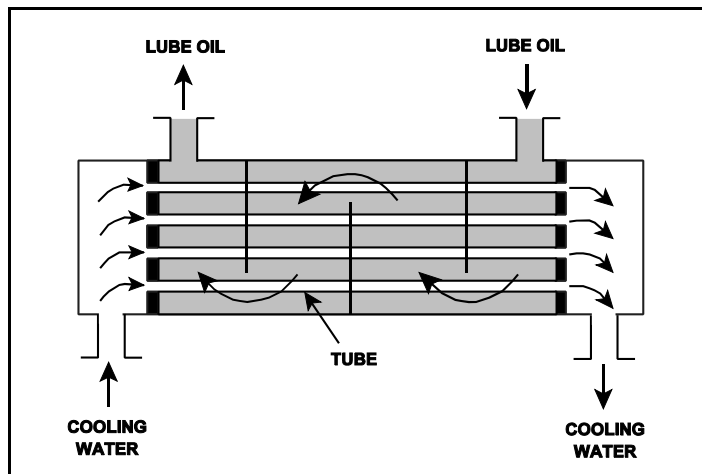

TOPIC: 291006
KNOWLEDGE: K1.16 [2.5/2.6]
QID: B1833 (P2233)

Refer to the drawing of an operating lube oil heat exchanger (see figure below).

If deposits accumulate on the outside of the cooling water tubes, cooling water outlet temperature will _____ and oil outlet temperature will _____. (Assume oil and cooling water inlet temperatures and flow rates remain the same.)

- A. increase; decrease
- B. increase; increase
- C. decrease; decrease
- D. decrease; increase

ANSWER: D.

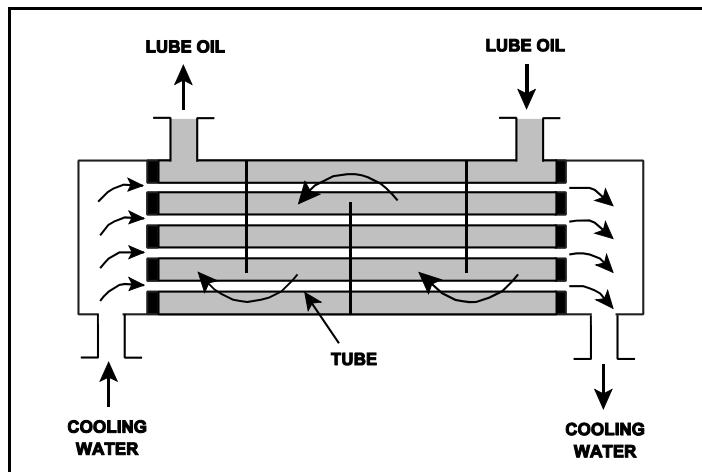

TOPIC: 291006
KNOWLEDGE: K1.17 [2.7/2.8]
QID: B234

Refer to the drawing of an operating cooling water system (see figure below) that is transferring heat between a low pressure (LP) and high pressure (HP) water system.

Which one of the following effects will initially occur as a result of a tube failure in the heat exchanger?

- A. Level in the surge tank will increase.
- B. HP fluid pump flow rate will decrease.
- C. HP fluid heat exchanger differential temperature will increase.
- D. LP fluid heat exchanger outlet temperature will increase.

ANSWER: D.

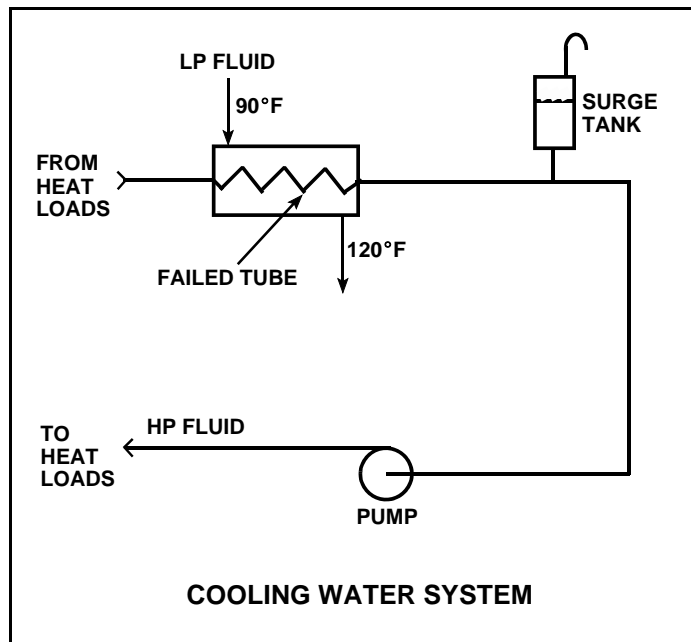

TOPIC: 291006
KNOWLEDGE: K1.17 [2.7/2.8]
QID: B332 (P331)

A nuclear power plant is operating at steady-state conditions with the main generator supplying 1,000 MW to the power grid. Assume main generator load remains constant.

If 1% of the tubes in the main condenser become plugged, condenser absolute pressure will _____; and condenser hotwell temperature will _____.

- A. increase; increase
- B. decrease; increase
- C. increase; decrease
- D. decrease; decrease

ANSWER: A.

TOPIC: 291006
KNOWLEDGE: K1.17 [2.7/2.8]
QID: B333 (P333)

A nuclear power plant is operating normally at 50% of rated power. Which one of the following will result from a cooling water tube rupture in the main condenser?

- A. Increased condenser vacuum
- B. Increased conductivity of the condensate
- C. Decreased condensate pump net positive suction head
- D. Decreased condensate pump flow rate

ANSWER: B.

TOPIC: 291006
KNOWLEDGE: K1.17 [2.7/2.8]
QID: B1535 (P1234)

Refer to the drawing of an operating cooling water system (see figure below).

Which one of the following will occur as a result of the indicated tube failure in the heat exchanger?

- A. High pressure (HP) fluid inventory increases.
- B. Pressure in the low pressure (LP) system decreases.
- C. Temperature in the low pressure (LP) system increases.
- D. Level in the surge tank decreases.

ANSWER: D.

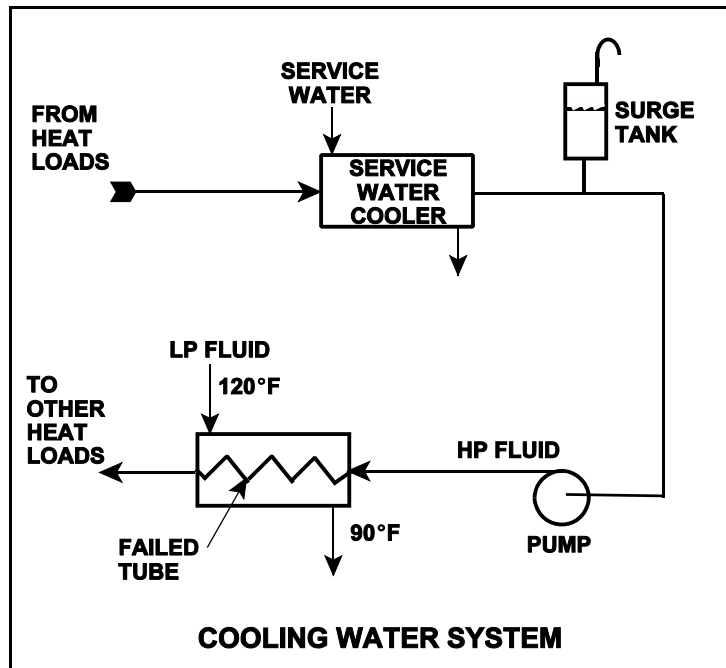

TOPIC: 291006
KNOWLEDGE: K1.17 [2.7/2.8]
QID: B1931 (P1134)

Which one of the following effects will occur as a result of multiple tube failures (leaks) in the main condenser with the plant at 50% power? (Assume condenser vacuum does not change.)

- A. Condensate depression will decrease.
- B. Condensate conductivity will increase.
- C. Condensate oxygen concentration will decrease.
- D. Condenser inlet cooling water flow rate will decrease.

ANSWER: B.

TOPIC: 291006
KNOWLEDGE: K1.17 [2.7/2.8]
QID: B3535 (P234)

Refer to the drawing of an operating cooling water system (see figure below).

Which one of the following effects would occur as a result of the failed tube in the heat exchanger?

- A. Level in the surge tank increases.
- B. Flow in the low pressure system reverses.
- C. Pressure in the low pressure system decreases.
- D. Low pressure fluid heat exchanger outlet temperature decreases.

ANSWER: D.

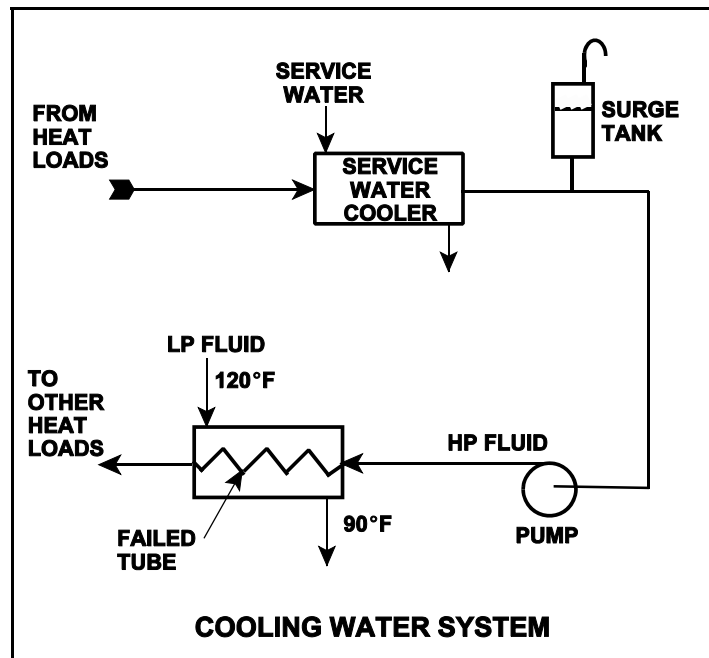

TOPIC: 291006
KNOWLEDGE: K1.17 [2.7/2.8]
QID: B4918 (P4917)

A nuclear power plant was initially operating at steady-state 50% rated thermal power with 50 gpm of main condenser cooling water inleakage through a cooling water tube rupture. Thermal power was then increased and is currently stable at 60%.

Assume that the size of the cooling water tube rupture does not change, and that the main condenser cooling water inlet pressure and inlet temperature do not change.

When compared to the flow rate of main condenser cooling water inleakage at 50% power, the flow rate of main condenser cooling water inleakage at 60% power is _____ because the main condenser pressure at 60% power is _____.

- A. higher; lower
- B. higher; higher
- C. lower; lower
- D. lower; higher

ANSWER: D.

TOPIC: 291006
KNOWLEDGE: K1.18 [2.8/2.9]
QID: B936 (P1912)

During normal nuclear power plant operation, why does air entry into the main condenser reduce the thermodynamic efficiency of the steam cycle?

- A. The rate of steam flow through the main turbine increases.
- B. The condensate subcooling in the main condenser increases.
- C. The enthalpy of the low pressure turbine exhaust increases.
- D. The air mixes with the steam and enters the condensate.

ANSWER: C.

TOPIC: 291006
KNOWLEDGE: K1.18 [2.8/2.9]
QID: B1236

During power plant operation, the accumulation of air and non-condensable gases in the main condenser will...

- A. not effect turbine work.
- B. not effect turbine efficiency.
- C. increase generator load.
- D. increase turbine backpressure.

ANSWER: D.

TOPIC: 291006
KNOWLEDGE: K1.18 [2.9/3.0]
QID: B4018 (P4016)

Refer to the drawing of an operating lube oil heat exchanger (see figure below).

Given the following initial parameters:

Cooling water inlet temperature (T_{cw-in}) = 75°F
Cooling water outlet temperature (T_{cw-out}) = 95°F
Oil inlet temperature (T_{oil-in}) = 150°F
Oil outlet temperature ($T_{oil-out}$) = 120°F

Air introduction to the heat exchanger results in some of the heat exchanger tubes becoming uncovered. As a result, T_{cw-out} decreases to 91°F. Assume the inlet temperatures, mass flow rates, and specific heats of both fluids remain the same.

Which one of the following will be the resulting temperature of the oil exiting the heat exchanger ($T_{oil-out}$)?

- A. 126°F
- B. 130°F
- C. 134°F
- D. 138°F

ANSWER: A.

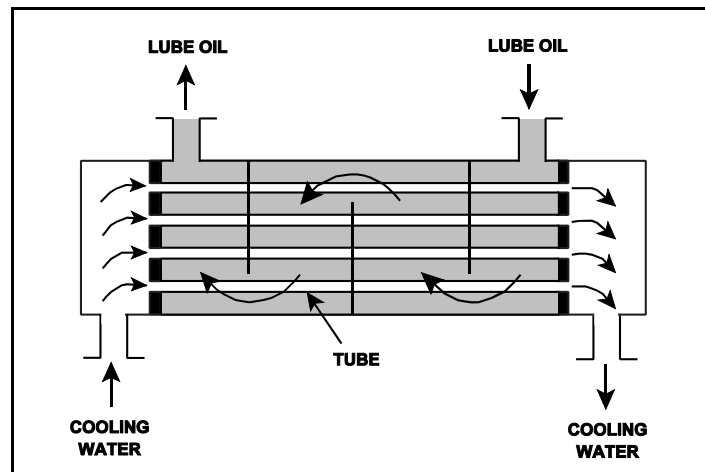

TOPIC: 291006
KNOWLEDGE: K1.18 [2.8/2.9]
QID: B4817 (P4816)

Refer to the drawing of an operating lube oil heat exchanger (see figure below).

Given the following initial parameters:

Cooling water inlet temperature (T_{cw-in}) = 75°F
Cooling water outlet temperature (T_{cw-out}) = 95°F
Oil inlet temperature (T_{oil-in}) = 150°F
Oil outlet temperature ($T_{oil-out}$) = 110°F

Air leakage into the heat exchanger causes some of the heat exchanger tubes to become uncovered. As a result, T_{cw-out} decreases to 89°F. Assume the inlet temperatures, mass flow rates, and specific heats of both fluids remain the same.

Which one of the following will be the new approximate temperature of the oil exiting the heat exchanger ($T_{oil-out}$)?

- A. 116°F
- B. 122°F
- C. 130°F
- D. 138°F

ANSWER: B.

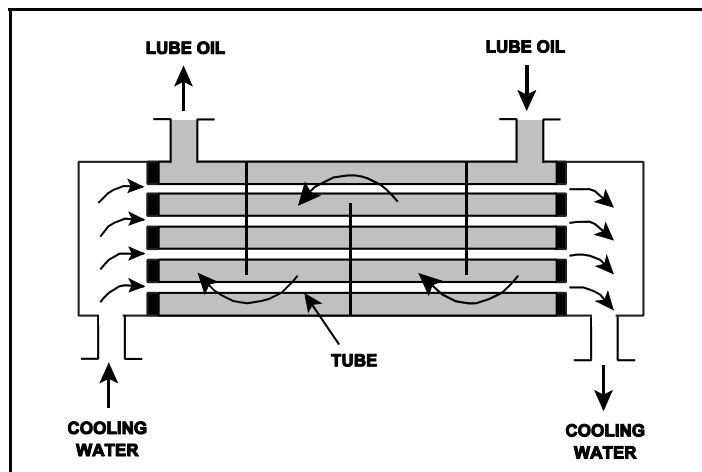

TOPIC: 291006
KNOWLEDGE: K1.18 [2.8/2.9]
QID: B5418 (P5417)

Refer to the drawing of an operating lube oil heat exchanger (see figure below).

The heat exchanger was operating with the following initial parameters:

Cooling water inlet temperature (T_{cw-in}) = 71 °F
Cooling water outlet temperature (T_{cw-out}) = 91 °F
Oil inlet temperature (T_{oil-in}) = 175 °F
Oil outlet temperature ($T_{oil-out}$) = 125 °F

The heat exchanger was vented, resulting in the following current parameters:

Cooling water inlet temperature (T_{cw-in}) = 71 °F
Cooling water outlet temperature (T_{cw-out}) = 95 °F
Oil inlet temperature (T_{oil-in}) = 175 °F
Oil outlet temperature ($T_{oil-out}$) = ?

Assume that the mass flow rates and specific heats of both fluids were unchanged.

Which one of the following is the current lube oil outlet temperature ($T_{oil-out}$)?

- A. 115 °F
- B. 120 °F
- C. 130 °F
- D. 135 °F

ANSWER: A.

