

Noise Assessment Guidelines

Foreword

In choosing among alternative sites for housing, potential noise problems are prominent among the issues that must be examined. These Noise Assessment Guidelines were developed to provide HUD field staff, interested builders, developers, and local officials with an easy-to-use method of evaluating noise problems with a minimum of time and effort.

We believe that this set of tools will simplify the process of balancing the goal of environmental protection with those of efficiency and reduced housing costs. We hope you will find them useful, and invite your comments.

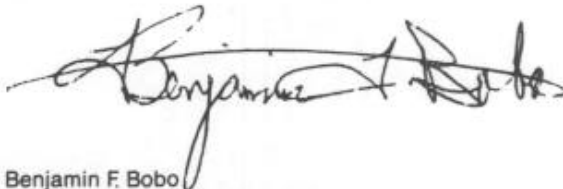

Benjamin F. Bobo
Acting Assistant Secretary for
Policy Development and Research



Stephen J. Bollinger
Assistant Secretary for
Community Planning and
Development

Preface

The Department of Housing and Urban Development, in its efforts to provide decent housing and a suitable living environment, is concerned with noise as a major source of environmental pollution and has issued Subpart B on Noise Abatement and Control to Part 51 of Title 24 of the Code of Federal Regulations.

The policy established by Subpart B embodies HUD objectives to make the assessment of the suitability of the noise environment at a site: (1) easy to perform; (2) uniformly applicable to different noise sources; and (3) as consistent as possible with the assessment policies of other Federal departments and agencies. In furtherance of these objectives, the Office of Policy Development and Research has sponsored research to provide site analysis techniques. These *Noise Assessment Guidelines* do not constitute established policy of the Department but do provide a methodology whose use is encouraged by HUD as being consistent with its objectives. The *Guidelines* provide a means for assessing separately the noise produced by airport, highway, and railroad operations, as well as the means for aggregating their combined effect on the overall noise environment at a site.

This booklet has been prepared by Bolt Beranek and Newman Inc., under Contract No. H-2243R for the U.S. Department of Housing and Urban Development. It is a revision of an earlier edition published in August 1971. With the exception of changes made by the Department, the contractor is solely responsible for the accuracy and completeness of the data and information contained herein.

Contents

III	Foreword
IV	Preface
2	Introduction
3	Combining Sound Levels in Decibels
4	Aircraft
4	Necessary Information
4	Evaluation of Site Exposure to Aircraft Noise
6	Roadways
6	Necessary Information
6	Evaluation of Site Exposure to Roadway Noise
6	Automobile Traffic
7	Adjustments for Automobile Traffic
8	Truck Traffic
8	Adjustments for Heavy Trucks
9	Attenuation of Noise by Barriers
10	Steps to Evaluate a Barrier
14	Railways
14	Necessary Information
14	Evaluation of Site Exposure to Railway Noise
14	Diesel Locomotives
14	Adjustments for Diesel Locomotives
15	Railway Cars and Rapid Transit Systems
15	Adjustments for Railway Cars and Rapid Transit Trains
17	References
18	Summary of Adjustment Factors

Introduction

These guidelines are presented as part of a continuing effort by the Department of Housing and Urban Development to provide decent housing and a suitable living environment for all Americans.

The procedures described here have been developed so that people without technical training will be able to assess the exposure of a housing site to present and future noise conditions. In this context, the site may hold only one small building, in which case the noise assessment is straightforward. Larger sites may hold larger buildings, or many buildings, and the noise level may be different at different parts of the site (or building). Assessments of the noise exposure should be made at representative locations around the site where significant noise is expected. These are designated as "Noise Assessment Locations," abbreviated NAL in the following text.

The only materials required are a map of the area, a ruler (straight edge), a protractor and a pencil. Worksheets and working figures are provided separately.

All of the information you need can be easily obtained – usually by telephone. For convenience, this information is listed at the beginning of each section under headings that indicate the most likely source. While you are obtaining this information, be sure to ask about any approved plans for future changes that may affect noise levels at the site – for example: land-use changes, changes in airport runway traffic, widening of roads, and so forth. In all evaluations, you

should assess the condition that will have the most severe or most lasting effect on the use of the site.

Wherever possible, you should try to assess noise environments expected at least ten years in the future.

The degree of acceptability of the noise environment at a site is determined by the outdoor day-night average sound level (DNL) in decibels (dB). The assessment of site acceptability is presented first as an evaluation of the site's exposure to three major sources of noise – aircraft, roadways, and railways. These are then combined to assess the total noise at a site. Worksheets are provided at the back of these Guidelines to use in summarizing your evaluations.

The noise environment at a site will come under one of three categories:

Acceptable (DNL not exceeding 65 decibels) The noise exposure may be of some concern but common building constructions will make the indoor environment acceptable and the outdoor environment will be reasonably pleasant for recreation and play.

Normally Unacceptable (DNL above 65 but not exceeding 75 decibels) The noise exposure is significantly more severe; barriers may be necessary between the site and prominent noise sources to make the outdoor environment acceptable; special building constructions may be necessary to ensure that people indoors are sufficiently protected from outdoor noise.

Unacceptable (DNL above 75 decibels) The noise exposure at the site is so severe that the construction cost to make the indoor

noise environment acceptable may be prohibitive and the outdoor environment would still be unacceptable.

When measuring the distance from the site to any noise source, measure from the source to the nearest points on the site where buildings having noise-sensitive uses are located. These points define the Noise Assessment Locations for the site. The relevant measurement location for buildings is a point 2 meters (6.5 feet) from the facade.

If at any point during the assessment the site's exposure to noise is found to be Unacceptable or Normally Unacceptable, every effort should be made to improve the condition, e.g., the location of the proposed dwellings can be changed or some shielding can be provided to block the noise from that source.

Where quiet outdoor space is desired at a site, distances should be measured from the important noise sources to the outdoor area in question and the combined noise exposure should be assessed.

Frequently, the locations of dwellings have not yet been specified at the time the noise assessment of a site is made. In these instances, distances used in the noise assessment should be measured as 2 meters less than the distance from the building setback line to the major sources of noise.

Combining Sound Levels in Decibels

The noise environment at a site is determined by combining the contributions of different noise sources. In these Guidelines, Workcharts are provided to estimate the contribution of aircraft, automobile, truck, and train noise to the total day-night average sound level (DNL) at a site. The DNL contributions from each source are expressed in decibels and entered on Worksheet A. The combined DNL from all the sources is the DNL for the site and is the value used to determine the acceptability of the noise environment.

Sound levels in decibels are *not combined by simple addition!* The following table shows how to combine sound levels:

Difference in Sound Level	Add to Larger Level
0	3.0
1	2.5
2	2.1
3	1.8
4	1.5
5	1.2
6	1.0
7	0.8
8	0.6
9	0.5
10	0.4
12	0.3
14	0.2
16	0.1
greater than 16	0

Use the table by first finding the numerical difference in sound level between two levels being combined. Entering the table with this value, find the value to be added to the larger of the two levels, add this value to the larger level to determine the total. Where more than two levels are to be combined, use the same procedure to combine any two levels; then use this subtotal and combine it with any other level, and so on. Fractional numerical values may be interpolated from the table; however, the final result should be rounded to the nearest whole number.

Example 1: In performing a site evaluation, the separate DNL values for airports, road traffic, and railroads have been listed on Worksheet A as 56, 63, and 61 decibels. In order to complete the final evaluation of the site, these separate DNL values must be combined. The difference between 63 and 56 is 7; from the table you find that 0.8 should be added to 63, for a subtotal of 63.8. The difference between 63.8 and 61 is 2.8; from the table you interpolate that approximately 1.9 should be added to 63.8 for a total of 65.7 or 66 dB when rounded to whole numbers. This example shows how noise from different sources may be Acceptable, individually, at a site, but when combined, the total noise environment may exceed the Acceptable DNL limit of 65 decibels.

Aircraft

Necessary Information

To evaluate a site's exposure to aircraft noise, you will need to consider all airports (civil and military) within 15 miles of the site. The information required for this evaluation is listed below under headings that indicate the most likely source. Before beginning the evaluation, you should record the following information on Worksheet B:

From the FAA Area Office or the Military Agency in charge of the airport:

- Are current DNL or NEF (Noise Exposure Forecast) contours available? Noise contours are available for almost all military airports. These contours have been developed and published as part of the Air Installation Compatible Use Zone (AICUZ) program of the Department of Defense. The contours are published normally as part of an AICUZ report. Noise contours are also available for many civil airports. When available, they are superimposed on a map with an appropriately marked scale (see Figure 1, page 4).
- Any available information about approved plans for runway changes (extensions or new runways).

From the FAA Control Tower or Airport Operations (if DNL or NEF contours are not available):

- The number of nighttime jet operations (10 p.m. - 7 a.m.)
- The number of daytime jet operations (7 a.m. - 10 p.m.)
- The flight paths of the major runways.
- Any available information about expected changes in airport traffic, e.g., will the number of operations increase or decrease in the next 10 or 15 years.

In making your evaluation, use the data for the heaviest air traffic condition, whether present or future.

Evaluation of Site Exposure to Aircraft Noise

If current DNL (or NEF) contours are available (as in Figure 1 page 4), locate the site on the map by referring to the marked distance scale. If there are no other noise sources in the area, you do not need to do anything else. If there are other noise sources affecting the site, you will need to find the precise DNL value so you can combine it with the other sources. Obtain the DNL at the appropriate NAL on the site by interpolation between the

contours on either side of the NAL. If NEF contours are used, estimate DNL by adding 35 decibels to the NEF values. Note that contours are usually provided in 5 decibel increments. (See Example 2 on page 4.) When supersonic aircraft operations are present, DNL contours are *required* for the assessment.

If DNL or NEF contours are *not* available, the DNL at a site may be estimated in several different ways:

- An FAA Handbook (Reference 1) can be used to estimate DNL contours for sites in general aviation airport vicinities. General aviation airports exclude commercial jet transports but may include business jets.
- A handbook available from EPA (Reference 2 at the back of this Guide) can be used to calculate DNL at individual points.
- A procedure for constructing approximate DNL contours for sites near commercial jet

Figure 1
Example of DNL Contours

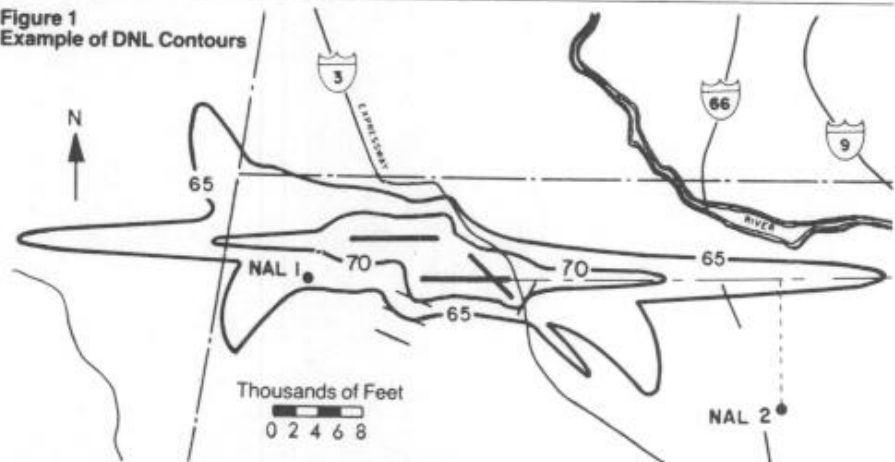

Example 2: The illustration in Figure 1 at the top of page 4 shows the NAL's on a map that has DNL contours. We find that NAL number 1 lies between the 65 and 70 dB contours and that NAL number 2 lies outside the 65 dB contour.

We find the DNL at NAL number 1 by interpolation from the distances between the NAL and the 65 and 70 dB contours.

By scaling off the map, we find that the distance from the NAL, measured perpendicularly to the contours, is 800 feet to the 65 dB contour and 2400 feet to the 70 dB contour. The distance between the 65 and 70 dB contours is $2400 + 800 = 3200$ feet. We find the DNL at the NAL number 1 to be 65 decibels plus $800/3200 \times 5$ decibels = 66.3 decibels.

Example 3: The illustration in Figure 2 at the bottom of page 5 shows an airport for which DNL or NEF contours are not available. The airport has 10 nighttime and 125 daytime jet operations.

To construct the approximate contours, we determine the effective number of operations as follows:

$$10 \text{ (nighttime)} \times 10 = 100$$

Add to this the actual number of daytime operations:

$$100 + 125 \text{ (daytime)} = 225$$

To determine the distances A and B in relation to the runway (see Figure 3, page 5), enter the effective number of operations on the horizontal scales of the charts in Figure 3;

airports without supersonic aircraft is as follows:

Determine the "effective" number of jet operations at the airport by first multiplying the number of nighttime jet operations by 10.

Then add the number of daytime jet operations to obtain an effective total (see Example 3, page 4).

On a map of the area showing the principal runways, mark the location of the site and, using the diagram and charts of Figure 3 on page 5, construct approximate DNL contours of 65, 70, and 75 dB for the major runways and flight paths most likely to affect the site. (see Figure 2, page 5.)

Although a site may be Acceptable for exposure to aircraft noise; exposure to other sources of noise, when combined with the aircraft noise, may make the site Unacceptable. Therefore, if necessary, values of aircraft noise exposure less than 65 dB can be estimated from Table 2. Scale the shortest

distance D^2 from the NAL to the flight path, as in Figure 2. Scale the distance D^1 from the 65 dB contour to the flight path. Divide D^2 by D^1 and enter this value into the following table to find the approximate DNL at the NAL.

Table 2

$\frac{D^2}{D^1}$	DNL dB
1.00	65
1.12	64
1.26	63
1.41	62
1.58	61
1.78	60
2.00	59
2.24	58
2.51	57
2.82	56
3.16	55

Figure 3
Charts for Estimating
DNL for Aircraft Operations

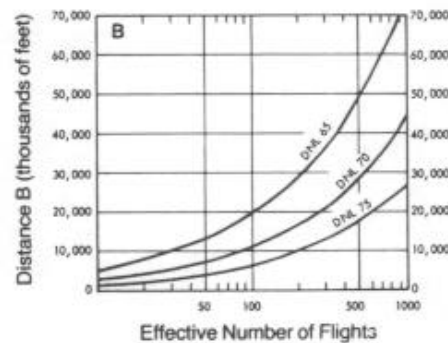
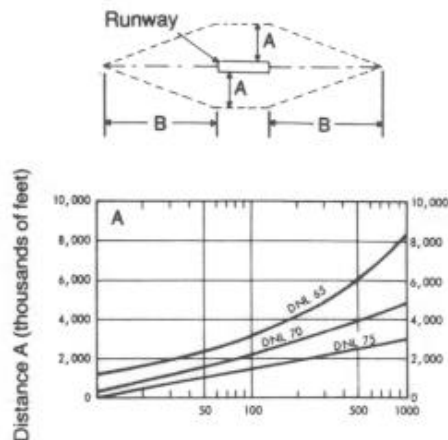
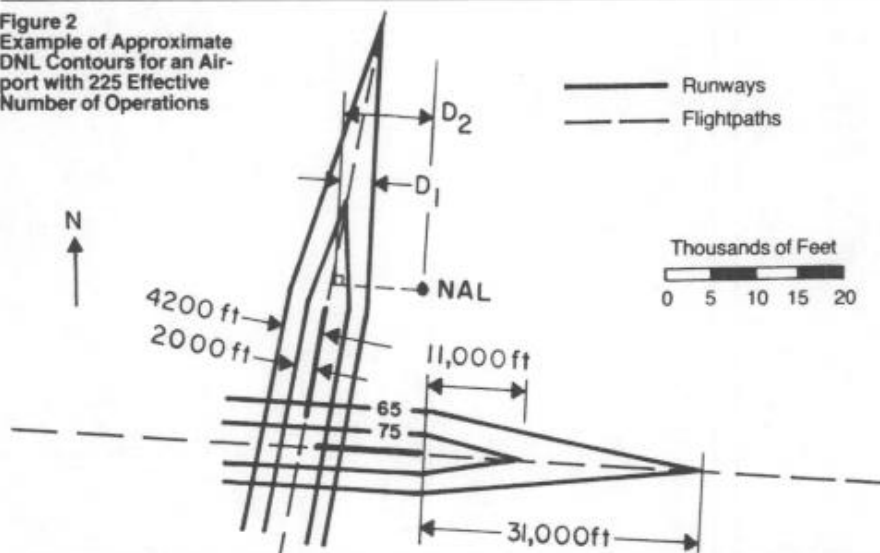

Figure 2
Example of Approximate
DNL Contours for an Air-
port with 225 Effective
Number of Operations



read up to the DNL curves; read across the chart to the left to obtain distances A and B from the vertical scales on the charts.

We find from Figure 3, for example, that for 225 effective operations, distance A is 4200 feet for the 65 dB contour and 2000 feet for the 75 dB contour. Distance B is 31,000 feet for the 65 dB contour and 11,000 feet for the 75 dB contour.

Example 4a: The NAL shown in Figure 2 is outside the 65 dB contour. The distance D^2 from the NAL to the flight path is 9700 feet. The distance D^1 from the 65 dB contour to the flight path, measured perpendicularly from the contour, is 3700 feet. The ratio D^2/D^1 is $9700/3700 = 2.62$. From Table 2 we find the DNL from the airport to be 56.6 dB. We do not know whether the site is Acceptable or not, however, since we must also assess the contribution of roadway and train noise to the total DNL at the site.

Example 4b: We observe that the perpendicular distance (D^2) from NAL number 2 (Figure 1) to the flight path is more than 3 times the distance (D^1) from the 65 dB contour to the flight path. From Table 2 we find that the contribution of the airport to the DNL at NAL number 2 is less than 55 decibels. We need not consider the airport further in accessing the noise environment at this site.

Roadways

Necessary Information

To evaluate a site's exposure to roadway noise, you will need to consider all roads that might contribute to the site's noise environment; roads farther away than 1000 feet normally may be ignored.

Before beginning the evaluation, determine if roadway noise predictions already exist for roads near the site. Also try to obtain all available information about approved plans for roadway changes (e.g., widening existing roads or building new roads) and about expected changes in road traffic (e.g., will the traffic on this road increase or decrease in the next 10 to 15 years).

If noise predictions have been made, they should be available from the City (County) Highway or Transportation Department. If not, record the following information on page 1 of Worksheet C:

- The distances from the NAL's for the site to the near edge of the nearest lane and the far edge of the farthest lane for each road.
- Distance to stop signs.
- Road gradient, if 2 percent or greater.
- Average speed.
- The total number of automobiles for both directions during an average 24-hour day. Traffic engineers refer to this as ADT, Average Daily Traffic (or sometimes AADT, meaning Annual Average Daily Traffic).
- The number of trucks during an average 24-hour day in each direction.

If possible, separate trucks into "heavy trucks" – those weighing more than 26,000 pounds with three or more axles – and "medium trucks" – those between 10,000 and 26,000 pounds. (Each medium truck is counted as equal to 10 automobiles.) Trucks under 10,000 pounds are counted as automobiles. Count buses capable of carrying more than 15 seated passengers as "heavy" trucks – others, as "medium" trucks. If it is

not possible to separate the trucks into those that are heavy and those that are not, treat *all* trucks as though they are "heavy."

Note: If the road has a gradient of 2 percent or more, record the numbers for uphill and downhill traffic separately since these figures will be needed later; otherwise, simply record the total number of trucks. Most often you will have to assume that the uphill and downhill traffic are equally split.

- The fraction of ADT that occurs during nighttime (10 p.m. to 7 a.m.). If this is unknown, assume 0.15 for both trucks and autos.

Evaluation of Site Exposure to Roadway Noise

Traffic surveys show that the amount of roadway noise depends on the percentage of trucks in the total traffic volume. To account for this effect, you must evaluate automobile and truck traffic separately and then combine the results.

The noise environment at each site due to traffic noise is determined by utilizing a series of Workcharts to define the contribution of automobiles and trucks from one or more roads at that site. Each noise source yields a separate DNL value.

Workchart 1 provides a graph for assessing a site with respect to the noise from automobiles, light and medium trucks; Workchart 2 provides a similar graph for assessment of heavy truck noise. These values are combined for each road affecting the noise environment at the site to obtain the total contribution of roadway noise. Remember, the noise from aircraft and railways must also be considered before determining the suitability of this site's noise environment.

Effective Distance

Before proceeding with these separate eval-

uations, however, determine the "effective distance" to each road from the dwelling or outdoor residential activity (the NAL's for the site) by averaging the distances to the nearest edge of the nearest lane and to the farthest edge of the farthest lane of traffic. (See Example 5, page 6, and Figure 4, page 7.)

Note: For roads with the same number of lanes in both directions, the effective distance is the distance to the center of the roadway (or median strip, if present).

Automobile Traffic

Workchart 1 was derived with the following assumptions:

- There is line-of-sight exposure from the site to the road; i.e., there is no barrier which effectively shields the site from the noise of the road.
- There is no stop sign within 600 feet of the site; traffic lights do not count because there is usually traffic moving on one street or the other.
- The average automobile traffic speed is 55 mph.
- The nighttime portion of ADT is 0.15.

If each road meets these four conditions, proceed to Workchart 1 for the evaluation. Enter the horizontal axis with the effective distance from the roadway to the NAL; draw a vertical line upward from this point. Enter the vertical axis with the effective automobile ADT; draw a horizontal line across from this point. (The "effective" automobile ADT is the sum of automobiles, light trucks, and 10 times the number of medium trucks in a 24-hour day.) Read the DNL value from Workchart 1 where the vertical and horizontal lines intersect. Record this value in column 16, Worksheet C.

But:

If any of the four conditions is different, make

Example 5: The site shown in Figure 4 is exposed to noise from three major roads: Road No. 1 has four lanes, each 12 feet wide, and a 30-foot wide median strip which accommodates a railroad track. Road No. 2 has four lanes, each 12 feet wide. Road No. 3 has six lanes, each 15 feet wide, and a median strip 30 feet wide.

The distance from NAL No. 1 to the near edge of Road No. 1 is 300 feet. The distance

to the far edge of Road No. 1 is 300 feet, plus the number of lanes times the lane width, plus the width of the median strip. Thus, the distance to the farthest edge of the road is:

$$300 + (4 \times 12) = 378 \text{ ft}$$

The effective distance is

$$\frac{378 + 300}{2} = 339 \text{ ft}$$

This is the value to be entered on line 1c of Worksheet C. The effective distances from the appropriate NAL's to Road No. 2 and Road No. 3 are found by the same method.

The distances shown in Figure 4 will be used for all roadway examples in this booklet.

Figure 4
Plan View of Site showing How Distance Should Be Measured from the Noise Assessment Location (NAL) of the Dwelling Nearest to the Source

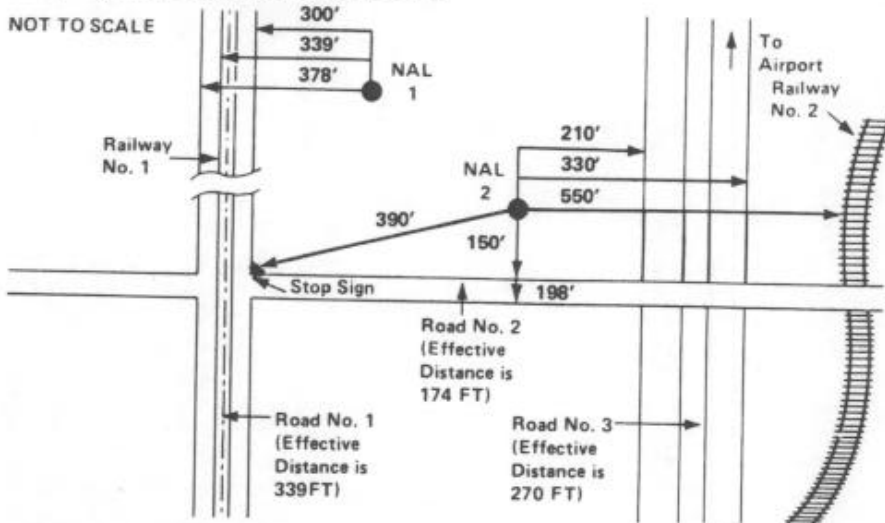

the necessary adjustments (on page 2, Worksheet C) listed below and then use Workchart 1 for the final evaluation.

First, a few general words about adjustments as they are applied in these Guidelines. Each Workchart has been derived for a baseline condition which is often found in practical cases. Where conditions differ from the baseline, they are accounted for by a series of one or more adjustment factors.

The adjustment factors are used as multipliers times the average number of vehicles operating during a 24-hour day. If more than one adjustment is required, it is not necessary that each be multiplied times the basic traffic flow separately; all adjustment factors are multiplied together, and then multiplied times the original traffic flow data. This will become clearer as you examine the Worksheets at the back of these Guidelines and

Figure 5
Use of Workchart 1 To Evaluate Automobile Traffic Noise

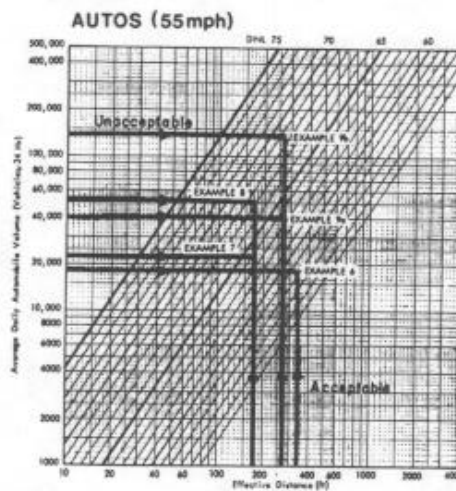

Example 6: Road No. 1 meets the four conditions that allow for an immediate evaluation. In obtaining the information necessary for this evaluation, it was found that the automobile ADT is 18,000 vehicles (Line 5c of Worksheet C). On Workchart 1 we locate on the vertical scale the point representing 18,000 and on the horizontal scale the point representing 339 feet (see Figure 5). (Note that we must estimate the location of this point.) Using a straight-edge we draw lines to connect these two values and find that the NAL exposure to automobile noise from this road is a DNL of 58 dB, as read from the scale at the top of the graph.

Example 7: Road No. 2 has a stop sign at 390 feet from NAL No. 2. The automobile ADT is reported as being 32,500 vehicles (line 5c of Worksheet C). From Table 3 we interpolate between 300 and 400 feet to find the adjustment factor for stop-and-go traffic to be 0.69. The adjusted traffic ADT is

$$0.69 \times 32,500 = 22,425 \text{ vehicles per day}$$

and with an effective distance of 174 feet from NAL No. 2, we find from Workchart 1 that the approximate value of DNL is 64 dB.

work through the examples. After you have become familiar with the Guidelines, you will be able to work examples directly from the worksheets without referring back to the text. To simplify your work, all the adjustment factors are summarized at the back of these Guidelines.

Adjustments for Automobile Traffic

Stop-and-Go Traffic:

If there is a stop sign (not a traffic signal) within 600 feet of the NAL so that the flow of traffic is completely interrupted on the road under consideration, find the stop-and-go adjustment factor for automobiles from Table 3. Enter this value in column 9 on Worksheet C.

Table 3

Distance from NAL to Stop Sign In Feet	Automobile Stop-and-Go Adjustment Factor
0	0.10
100	0.25
200	0.40
300	0.55
400	0.70
500	0.85
600	1.00

Average Traffic Speed:

If the average automobile speed is other than 55 mph, enter the appropriate adjustment from Table 4 in column 10 of Worksheet C.

Table 4

Average Traffic Speed	Auto Speed Adjustment Factor
20 (mph)	0.13
25	0.21
30	0.30
35	0.40
40	0.53
45	0.67
50	0.83
55	1.00
60	1.19
65	1.40
70	1.62

Example 8: Suppose that the stop sign on Road No. 2 were replaced by a traffic signal for which no stop-and-go adjustment is made and that the ADT increases to 75,000 vehicles. In addition, assume that the average speed is 45 mph instead of 55 mph. You adjust the new automobile ADT of 75,000 vehicles by the Auto Speed Adjustment Factor from Table 4

$$0.67 \times 75,000 = 50,250 \text{ vehicles}$$

and at an effective distance of 174 feet find from Workchart 1 that the approximate value of DNL is 67 dB.

Nighttime Adjustment.

DNL values are affected by the proportion of traffic volume that occurs during "daytime" (7 a.m. to 10 p.m.) and "nighttime" (10 p.m. to 7 a.m.). The graph on Workchart 1 assumes that 15 percent of the total ADT occurs during nighttime. If a different proportion of the traffic occurs at night, find the appropriate nighttime adjustment factor from Table 5. Record your answer in column 11 of Worksheet C.

Table 5

Nighttime Fraction of ADT	Nighttime Adjustment Factor
0	0.43
0.01	0.46
0.02	0.50
0.05	0.62
0.10	0.81
0.15	1.00
0.20	1.19
0.25	1.38
0.30	1.57
0.35	1.77
0.40	1.96
0.45	2.15
0.50	2.34

Once you have selected all the appropriate adjustment factors and entered them on page 2 of Worksheet C, multiply all the factors together, then multiply by the automobile ADT (column 12) for 24 hours, found on page 1 of Worksheet C. The resulting adjusted ADT should be entered in column 13. This is the ADT value to be used, in conjunction with the effective distance from the NAL to the road, to find the DNL value from Workchart 1. Enter this DNL value in column 14 of Worksheet C. Remember this is the DNL from automobile (as well as light and medium truck) noise; you must still find the DNL contribution from heavy truck noise in order to obtain the total DNL produced by the roadway you are assessing.

Example 9a: Road No. 3 is a limited access highway with no stop signs and the average speed is 55 mph. Current traffic data indicate an automobile ADT of 40,000 vehicles of which 15 percent occurs during nighttime hours (10 p.m. to 7 a.m.). With an effective distance of 270 feet to NAL No. 2, Workchart 1 is used to show that the DNL for existing automobile traffic is between 63 and 64 dB. Round off to 64 dB.

Attenuation of Noise by Barriers:

This adjustment reduces the noise produced by automobiles and trucks on the same road. Instructions for this adjustment appear after the noise assessment for truck traffic below.

Truck Traffic

Wherever possible, separate the average daily volume of trucks into heavy trucks (more than 26,000 pounds vehicle weight and three or more axles); medium trucks (less than 26,000 pounds but greater than 10,000 pounds), light trucks (counted as if they are automobiles). You should already have accounted for medium and light trucks in your automobile evaluation. Do not forget that buses that can carry more than 15 seated passengers are counted as heavy trucks. Heavy trucks (including buses) must be analyzed separately because they have quite different noise characteristics. If it is not possible to separate the trucks into those that are heavy and those that are not, treat *all* trucks as though they are "heavy."

Workchart 2, which is used to evaluate the site's exposure to heavy truck noise, was derived with the following assumptions:

- There is line-of-sight exposure from the site to the road; i.e., there is no barrier which effectively shields the site from the road noise.
- The road gradient is less than 2 percent.
- There is no stop sign (traffic signals are permissible) within 600 feet of the site.
- The average truck traffic speed is 55 mph.
- The nighttime fraction of ADT is 0.15.

If the road meets these five conditions, proceed to Workchart 2 for an immediate evaluation of the site's exposure to heavy truck noise from that road.

But:

If any of the conditions is different, make the

Example 9b: However, traffic projections estimate that in 10 years the ADT will increase to 100,000 vehicles at an average speed of 55 mph and nighttime usage will increase to 25 percent. For future traffic, you must adjust the future ADT of 100,000 for the effect of increased nighttime use. From Table 5, you find an adjustment factor of 1.38. The adjusted ADT is

$$1.38 \times 100,000 = 138,000$$

and at an effective distance of 270 feet you find from Workchart 1 that the DNL will increase to 69 dB; therefore, provision for extra noise control measures should be explored. We will examine in Example 13 the effect of terrain as a shielding barrier that provides sound attenuation.

necessary adjustment(s) listed below and then use Workchart 2 for the evaluation.

Figure 6. Use of Workchart 2 to Evaluate Heavy Truck Noise

Heavy Trucks (55 mph)

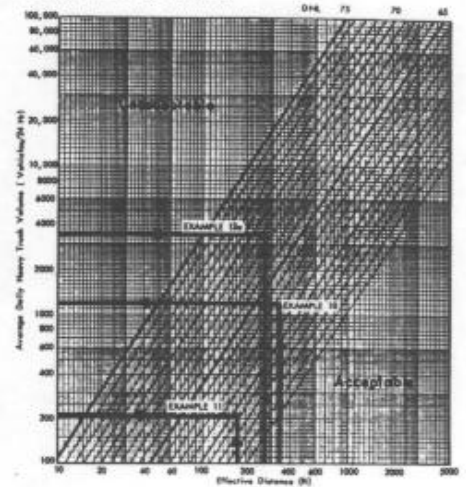

Adjustments for Heavy Trucks

Road Gradient:

If there is a gradient of 2 percent or more, find the appropriate adjustment factor, for heavy trucks going uphill only, as shown in Table 6. List this factor in column 17 of Worksheet C.

Table 6

Percent of Gradient	Adjustment Factor
2	1.4
3	1.7
4	2.0
5	2.3
6 or more	2.5

Example 10: Road No. 1 on Figure 4 meets the four conditions that allow for an immediate evaluation. The ADT for heavy truck flow is 1200 vehicles. Workchart 2 shows that the exposure to truck noise from this road at an effective distance of 339 feet is a DNL of 63 dB at NAL No. 1.

Average Traffic Speed:

Make this adjustment if the average speed differs from 55 mph. If the average truck speed differs with direction, treat the uphill and downhill traffic separately. Select the appropriate adjustment factors from Table 7 below, entering them in column 18 of Worksheet C.

Table 7

Average Traffic Speed MPH	Heavy Truck Speed Adjustment Factor
50 or less	0.81
55	1.00
60	1.17
65	1.38

Once you have found the speed adjustment factor, you can combine the uphill and downhill traffic. For uphill traffic, multiply the gradient factor times the speed adjustment factor times uphill traffic volume (truck ADT column 19) (assuming one half the total 24-hour average number of trucks unless specific information to the contrary exists), entering the product in column 20. Multiply the speed adjustment factor for downhill traffic times the downhill traffic volume (truck ADT/2 column 19). Add the values for uphill and downhill traffic, entering this sum in column 21. You may now complete the assessment of heavy truck noise without regard to uphill and downhill traffic separation.

Stop-and-Go Traffic:

If there is a stop sign (remember, not a traffic signal) within 600 feet of an NAL for the site on the road being assessed, find the adjustment factor determined according to Table 8. Enter it in Column 22 of Worksheet C.

Table 8

Heavy Truck Traffic Volume per Day	Heavy Truck Stop-and-Go Adjustment Factor
Less than 1200	1.8
1201 to 2400	2.0
2401 to 4800	2.3
4801 to 9600	2.8
9601 to 19,200	3.8
More than 19,200	4.5

Nighttime Adjustment

After all the above adjustments are made, do not forget to adjust for nighttime operations if they are not 15 percent of the total ADT, using the factors obtained from Table 5 just as for automobiles. Enter this value in column 23 of Worksheet C.

At this point, multiply the adjustment factors for nighttime and stop-and-go traffic times the heavy truck traffic volume in column 21 to find the adjusted heavy truck ADT, entering the product in column 24. Use this value and the effective distance from the NAL to the road to find the truck DNL from Workchart 2, entering your answer in column 25 of Worksheet C. If no shielding barriers are to be considered, combine the DNL from heavy trucks with the DNL from automobiles (column 14). The result is the DNL from the road being assessed and should be entered on Worksheet C.

But:

If a shielding barrier is to be considered for the site, make the analysis described below separately for automobiles and then for heavy trucks *before* combining the DNL values. This step is necessary since barriers are far more effective for automobiles than for heavy trucks. Once you have found the amount of attenuation provided by the barrier for automobiles, enter it in column 15. Find the value of barrier attenuation for heavy

trucks and enter it in column 25. Subtract these attenuation values from the DNL values obtained previously (columns 14 and 24), entering the reduced DNL values in columns 16 and 27. Combine the automobile and heavy truck DNL values, reduced by the attenuation provided by the barrier, to find the final DNL produced by the roadway at the site.

Remember to combine the contributions to DNL of *all* roads that affect the noise environment at each NAL for the site to obtain the total DNL from all roadways. Enter this DNL on both Worksheet C and the summary Worksheet A.

Attenuation of Noise by Barriers

Noise barriers are useful for shielding sensitive locations from ground level noise sources. For example, a barrier may be the best way to deal with housing sites at which the noise exposure is not acceptable because of nearby roadway traffic.

A barrier may be formed by the road profile, by a solid wall or embankment, by a continuous row of noise-compatible buildings, or by the terrain itself. To be an *effective* shield, however, the barrier must block all residential levels from line of sight to the road; it must not have any gaps that would allow noise to leak through.

Some Preliminary Matters:

In evaluating noise barrier performance, you will be working with different kinds of "distances" between the sound source, the observer, and the barrier.

Actual Distance – the existing distance that would be measured using a tape measure with no corrections or adjustments. This may mean one of two things, *depending on the application*; either the:

- *slant distance* – the actual distance,

Example 11: Road No. 2 has a stop sign at 390 feet from NAL No. 2. There is also a road gradient of 4 percent. No heavy trucks are allowed on this road, but a schedule shows an average of 12 large buses pass along the road per hour between 7 a.m. and 10 p.m., although no buses are scheduled during the remaining nighttime period. The buses are equally divided in each direction along the road. (Remember large buses, those that carry over 15 seated passengers, count as heavy trucks.)

We find the ADT for the "heavy trucks" (the buses in this case) by multiplying the average number of vehicles per hour by the number of hours between 7 a.m. and 10 p.m. That is, $12 \times 15 = 180$, or 90 vehicles in each direction. We find from Table 6 that the gradient adjust-

ment factor for uphill traffic is 2.0. We find the truck volume adjusted for gradient is

$$\begin{aligned} \text{uphill:} & 90 \times 2.0 = 180 \\ \text{downhill:} & = 90 \\ \text{total (column 21)} & = 270 \text{ vehicles} \end{aligned}$$

From Table 8, we find the adjustment factor for stop-and-go traffic to be 1.8.

We also remember that we have no buses in the nighttime period and find the factor in Table 5 on page 8 for zero nighttime operations to be 0.43.

Our final adjusted ADT is (column 24)

$$1.8 \times 0.43 \times 270 = 209 \text{ Vehicles}$$

From Workchart 2, with an effective distance of 174 feet, we find a DNL of 59 dB.

Example 12a: Road No. 3 is a depressed highway and the profile shields all residential levels of the housing from line of sight to the traffic. The average truck speed is 50 mph. The ADT for heavy trucks is 4400 vehicles. We adjust for average speed (from Table 7)

$$4400 \times 0.81 = 3564$$

and find from Workchart 2 that, with an effective distance of 270 feet, the DNL from truck noise would be 69 dB if no barrier existed. We proceed to analyze the barrier attenuation.

measured along the line of sight between two points; or the

- *map distance* – the actual distance, measured on a horizontal plane, between the two points, as on a map or on the project plan.

For an observer high in an apartment tower, the slant distance to the road may be much longer than the map distance.

Barrier effectiveness is expressed in terms of noise attenuation in decibels (dB), determined with the aid of Workchart 6. This numerical value is subtracted from the previously calculated DNL in order to find the resultant DNL at the Noise Assessment Location.

Note: A noise barrier can be considered as a means of protecting a site from noise even if it cannot wrap around the site to shield from view practically all of the source of noise at every sensitive location on the site. It must be recognized, however, that such a barrier is much less effective than an ideal barrier. (See Workchart 7 and Step 6 below.)

Barriers of reasonable height cannot be expected to protect housing more than a few stories above ground level. Barriers will generally protect the ground and the first two or three floors, but not the higher floors. If there are to be frequently occupied balconies on the upper levels, one solution is to move the building farther from the noise source and face the sensitive areas away from the noise.

Steps to Evaluate a Barrier

1. For the observer's position, use the mid-height of the highest residential level. For the source position, use the following heights (see Figure 7):

- autos, medium trucks, railway cars – the road or railway surface height
- heavy trucks – 8 feet above the road surface

- diesel locomotives or trains using horns or whistles at grade crossings – 15 feet above the rails.

Figure 7.
Source Heights to Be Used in Roadway Barrier Designs

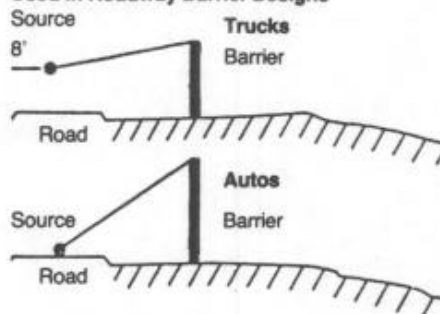

Get accurate values for the following quantities: *h*, the shortest distance from the barrier top to the line of sight from source to observer; *R* and *D*, the slant distances along the line of sight from the barrier to the source and observer, respectively (see Figure 8).

Figure 8.
Generalized Geometry of Acoustical Barrier

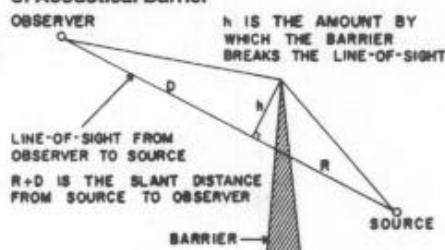

Specifically, *R* and *D* are the two segments into which *h* breaks the line of sight. Note that *h* is *not* the height of the barrier above the ground but the distance from the barrier top to the line of sight.

2. Enter at the top of Workchart 6 with the value of *h* on the left-hand scale; move right to intersect the curve corresponding to *R* (or *D*, whichever is *smaller*).

3. Move down to intersect the curve corresponding to the value of *D/R* (or *R/D*, whichever is *smaller*).

4. Move right to intersect the vertical scale in order to find the barrier shielding value *A* in decibels.

5. Interruption of the line of sight with a barrier between the noise source and an observer reduces the amount of sound attenuation provided by the ground. Find the amount of this loss *B* from the table on Workchart 6 by entering the table with the value of *D/R*. Find the barrier attenuation value *S* corresponding to an ideal barrier that completely hides the noise source from view by subtracting *B* from the value of *A* obtained in Step 4.

6. If the barrier exists along only a part of the road so that unshielded sections of the road would be visible from the site, the barrier is less effective than an ideal barrier. On a plan view of the site, locate the two ends of the barrier and draw lines from these points to the Noise Assessment Location. Use a protractor to measure the angle formed at the NAL by the two lines. Enter the horizontal scale of Workchart 7 with the values of this angle; read up to the curve having the value of *S* determined from Step 5 (interpolating if necessary); read left across to the vertical scale labeled "actual barrier performance" to find the value of *FS* to use for the actual barrier in question.

7. Subtract the barrier attenuation value *S* (or *FS* if adjusted for finite barrier length according to Workchart 7) from the value of DNL previously determined to reevaluate the site with the noise barrier in place.

Example 12b: (Refer to Figure 9.) Six stories are planned for the housing where the site has an elevation of 130 feet. The effective elevation for the highest story is found by multiplying the number of stories by 10 feet, adding the site elevation, and subtracting 5 feet.

$$(6 \times 10) + 130 - 5 = 185 \text{ feet}$$

The barrier, which in this case is formed by the road profile, has no "height" other than the elevation of the natural terrain above the noise sources traveling on the roadway. The important dimensions are indicated in Figure 9.

Some people with a technical background will be able to fit the geometric diagram to the site situation readily, working from the project drawings and a scratch sheet.

But if you are *not* confident of your geometry, Workchart 5 gets you the values of *R*, *D*, and *h* from the map distances and elevations of the site. We illustrate that procedure in this example.

First, enter the elevations of the source (*S*), the observer (*O*), and the top of the barrier (*H*), as well as the map distances from the barrier to the source (*R'*) and observer (*D'*), at the top right of Workchart 5. Then, follow the steps on that Workchart to derive the values of *h*, *R*, and *D* that are needed in using Workchart 6.

Entering Workchart 6 at the upper left with the value of *h* (5.5 feet), we move horizontally

Figure 9.
Detail of Site Showing Measurements
Necessary for a Barrier Adjustment

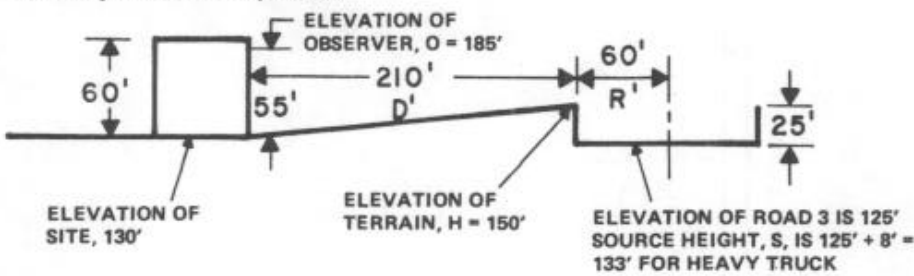

Figure 10.
Use of Workchart 5 to Determine Barrier
Dimensions in Example 12b

Workchart 5
Noise Barrier

To find R, D and h from Site Elevations and Distances

Fill out the following worksheet (all quantities are in feet):

Enter the values for:

H = 150 R = 60
S = 133 D = 210
O = 185



1. Elevation of barrier top minus elevation of source [1] 150] - [2] 133] = [3] 17]
2. Elevation of observer minus elevation of source [4] 185] - [5] 133] = [6] 52]
3. Map distance between source and observer (R + D) [7] 270]
4. Map distance between barrier and source (R) [8] 60]
5. Line 2 divided by line 3 [9] 52] ÷ [7] 270] = [10] 0.19]
6. Square the quantity on line 5 (i.e., multiply it by itself), always positive [11] 0.19] × [10] 0.19] = [12] 0.04]
7. 40% of line 6 [13] 0.4] × [12] 0.04] = [14] 0.016]
8. One minus line 7 [15] 1.0] - [14] 0.016] = [16] 0.984]
9. Line 2 times line 4 (will be negative if line 2 is negative) [17] 52] × [8] 60] = [18] 11.4]
10. Line 1 minus line 9 [19] 17] - [18] 11.4] = [20] 5.6]
11. Line 10 times line 8 [21] 5.6] × [8] 60] = [22] 5.5] = h
12. Line 5 times line 10 [23] 0.19] × [10] 5.6] = [24] 1.06]
13. Line 4 divided by line 11 [25] 60] ÷ [22] 5.5] = [26] 61]
14. Line 13 plus line 12 [27] 61] + [24] 1.06] = [28] 62] = R
15. Line 3 minus line 4 [29] 270] - [8] 60] = [30] 210]
16. Line 15 divided by line 9 [31] 210] ÷ [9] 0.19] = [32] 213]
17. Line 16 minus line 12 [33] 213] - [24] 1.06] = [34] 212] = D

(Note: the value on line 2 may be negative, in which case so will the values on lines 5, 8, and 12; line 1 may also be negative. Remember, then, in

lines 10, 14, and 17, that adding a negative number is the same as subtracting: $x + (-y) = x - y$. And subtracting a negative number is like adding: $x - (-y) = x + y$.)

Round off R and D to nearest integer, h to one decimal place.

to the right until we meet the value of R or D, whichever is smaller: in this example, $R = 62$ feet. From that point we drop vertically downward until we meet the value of R/D or D/R , whichever is smaller: in this case, $R/D = 0.29$. From that point, move horizontally to the right to find the value for $A = 9$ dB. Entering the table for determining loss of ground attenuation effect due to the barrier with a value for D/R of 3.5, the reduction in attenuation (B) is found to be 3 dB. Subtracting 3 dB from 9 dB provides a net attenuation of 6 dB. With 6 dB of attenuation, the original DNL of 69 dB (Example 12a) is reduced to 63 dB.

Example 13: An alternative approach, which is somewhat more direct, is illustrated here for the noise of automobiles on Road No. 3.

A preliminary step is to make an accurately scaled sketch of the general geometry introduced on page 8. It must include the positions of the source (this time at the road surface), the observer, and the top of the barrier; and will show the distances h, R, and D. Such a sketch is shown superimposed on the profile of the road and its neighborhood in Figure 12.

Figure 11.
Use of Workchart 6 to Evaluate Barrier
in Examples 12b, 13 and 14

Noise Barrier Workchart 6

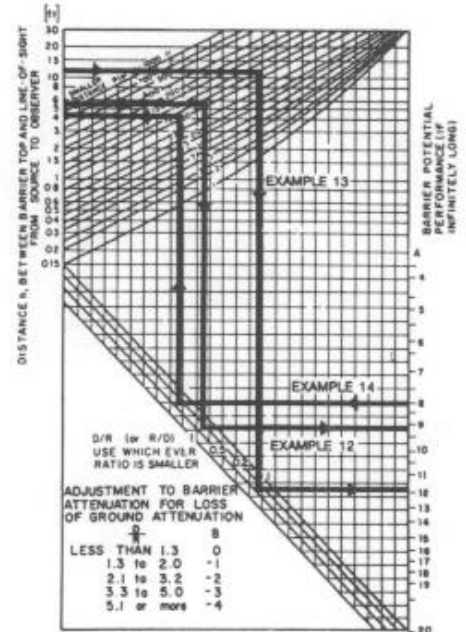

If we carefully scale the dimensions directly from this sketch, we find the following values for h, R, and D:

$$R = 63 \text{ feet}$$

$$D = 214 \text{ feet}$$

$$h = 11 \text{ feet}$$

$$R/D = 0.3$$

The barrier attenuation is found, by entering Workchart 6 with these values, to be $A = 12$ dB. It is larger than that found for trucks because the noise source is lower and is, therefore, better shielded by the barrier. The loss from ground attenuation is again $B = 3$ dB for a net attenuation of $12 - 3 = 9$ dB. In Example 9b, we found that the DNL

Figure 12.
Sketch Showing Dimensions for Example 13

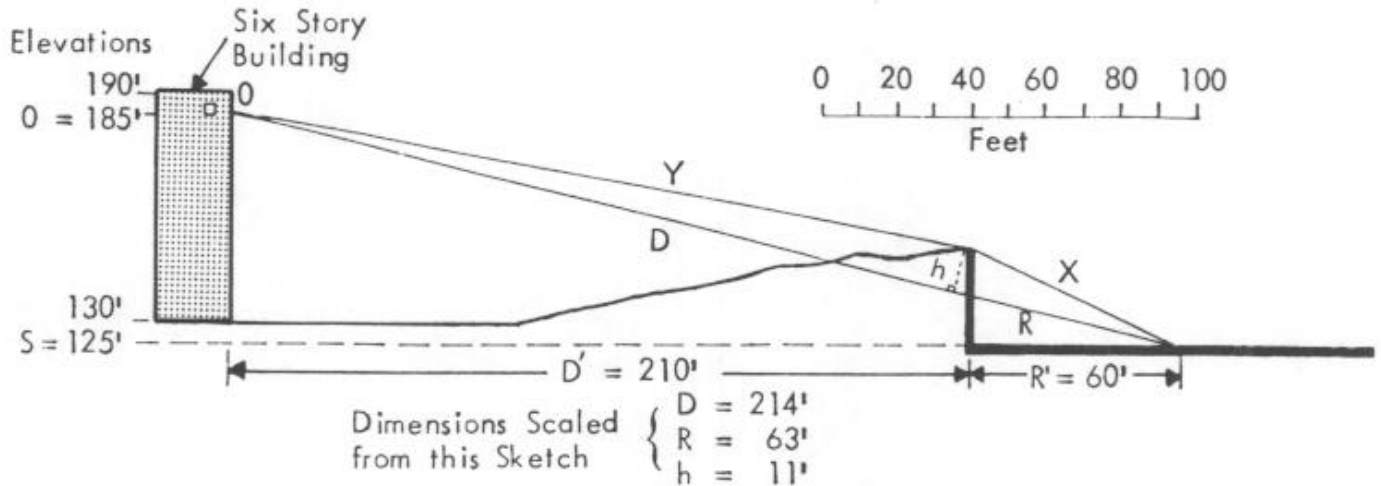

for the projected traffic volume of 100,000 vehicles per day was 69 dB if no consideration was given the shielding provided by the terrain. Subtracting the 9 dB attenuation from 69, we find the partial DNL for automobiles is 60 dB.

In order to find the combined truck and automobile noise for Road No. 3, we combine the 63 dB of truck noise with the 60 dB of automobile noise using Table 1. We find that 1.8 should be added to 63 dB, for a combined DNL of 64.8 dB, or 65 dB when rounded to the nearest whole number.

Example 14: Where no natural barrier exists, Workchart 6 can be used in reverse to estimate the height of a barrier needed to obtain a required attenuation. In example 9b we found that, without any attenuation from terrain or a barrier, the automobile traffic produced a DNL of 69 dB, and in Example 12a the heavy truck traffic produced a DNL of 69 dB. When combined, the total DNL is 72 dB. Suppose the terrain were not rising between NAL and Road No. 3, as shown in Figure 12, but instead was level between the NAL and the edge of the road, as shown in Figure 13. We want to find out how high a wall, infinite in length, would be required at the edge of the road to reduce the combined truck and automobile noise to less than 65 dB. We have found in the previous examples that a barrier

of a given height will provide more attenuation for automobiles than it will for trucks. As a first step in our analysis, we will find the height of a wall that will reduce the truck noise to just below 65 dB, say 64 dB, and then find out whether the additional attenuation it provides for automobile noise will be sufficient to reduce the combined truck and automobile noise to less than 65 dB. We begin by finding the height of wall that will provide 5 dB attenuation for truck noise.

We estimate that the ratio of R/D is about the same as R'/D' , the ratio of horizontal distance in Figure 13, which is equal to 0.29. Before entering Workchart 6, we find from the loss of ground attenuation table that for $D/R = 3.4$ we will lose 3 dB attenuation from an ideal barrier. In order to have a net attenu-

Figure 13.
Sketch Showing Dimensions for Example 14

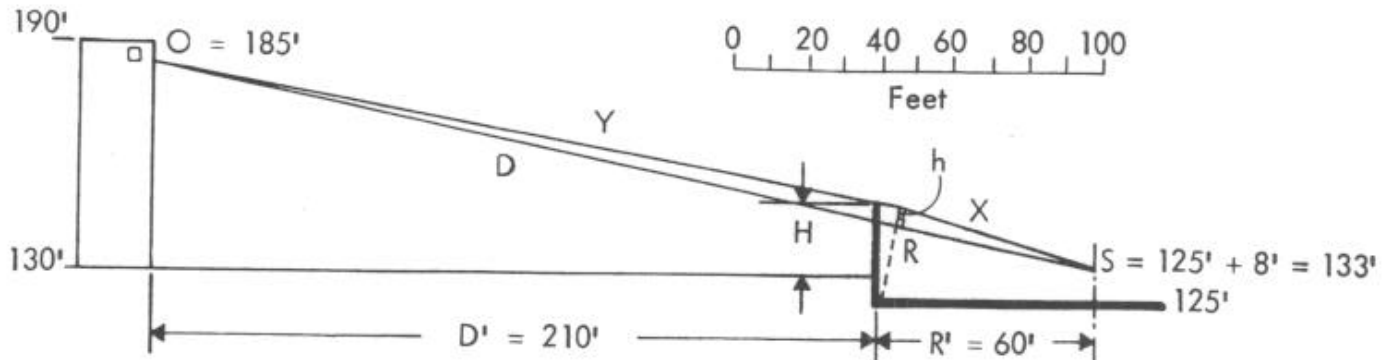

tion of 5 dB, we must have an ideal barrier that provides $5 + 3 = 8$ dB attenuation.

Entering Workchart 6 on the right side scale A at 8 decibels, we move across to the diagonal lines, finding 0.29 by interpolating between the lines marked at 0.2 and 0.5. Moving directly up to a point midway between the R lines of 50 and 70, we find our estimated R of approximately 60. Moving across to the left we find that the line of sight between the observer and the truck source height must be broken by a value of h equal to 4.5 feet.

We can determine the height of the wall H in several ways. By drawing $h = 4.5$ feet to scale on Figure 13, we can scale the total wall height H to be approximately 20 feet. Those who feel comfortable with geometry can

calculate H by using the similar triangle relationships in Figure 13 to determine that H is 19.1 feet.

Now we must find how much a wall 19 feet high will attenuate automobile noise, remembering that the source height for automobiles is at the road surface elevation of 125 feet. By scaling the drawing, or by geometry, we determine that the line of sight between the observer position and the automobile source is broken by a value of h that is approximately 13 feet. Entering Workchart 6 at 13 feet we find, for $R = 60$ feet and $R/D = 0.29$, that the potential barrier attenuation is 12dB. We must reduce this by 3 dB for loss of ground attenuation to find the actual shielding of automobile noise to be 9

dB. The original 69 dB of automobile noise is reduced to $69 - 9 = 60$ dB.

Finally, we combine the heavy truck noise, attenuated by the wall to $69 - 5 = 64$ dB, with the automobile noise reduced to 60 dB, to find a combined DNL of 65.5 dB, or 66 dB when rounded upward. Remember, however, that this is for an infinite wall. Further adjustments would have to be made once the actual length was known.

Railways

Necessary Information

To evaluate a site's exposure to railway noise, you will need to consider all rapid transit lines and railroads within 3000 feet of the site (except totally covered subways). The information required for this evaluation is listed below under headings that indicate the most likely source.

Before beginning the evaluation, you should record the following information on Worksheet D:

From the area map and/or the (County) Engineer:

- The distance from the appropriate NAL on the site to the center of the railway track carrying most of the traffic.

From the Supervisor of Customer Relations for the railway:

- The number of diesel trains and the number of electrified trains in both directions during an average 24-hour day.
- The fraction of trains that operate during nighttime (10 p.m. - 7 a.m.) If this is unknown, assume 0.15.
- The average number of diesel locomotives per train. If this is unknown, assume 2.
- The average number of railway cars per diesel train and per electrified train. If this is unknown, assume 50 for diesel trains and 8 for electrified trains.
- The average train speed. If this is unknown, assume 30 mph.
- Is the track made from welded or bolted rails?

From the Engineering Department of the railway:

- Is the site near a grade crossing that requires prolonged use of the train's horn or whistle? if so, where are the whistle posts located? (Whistle posts are signposts which

tell the engineer to start blowing the horn or whistle. Every grade crossing has whistle posts and they are listed on the railroad's "track charts." If traffic on the track is one-way, there will be only one whistle post. The grade crossing itself is the other "whistle post."

Electrified rapid transit and commuter trains that do not use diesel engines should be treated the same as railway cars.

Note: Buildings closer than 100 feet to a railroad track are often subject to excessive vibration transmitted through the ground. Construction at such sites is discouraged.

Evaluation of Site Exposure to Railway Noise

Railway noise is produced by the combination of diesel engine noise and railway car noise. These Guidelines provide for the separate evaluation of diesel locomotives and railroad cars, and then the combination of the two, in order to obtain the DNL from trains. When rapid transit or electrified trains that do *not* use diesel engines are the only trains passing near a site go directly to the second part of the evaluation since these trains are treated in the same manner as railway cars.

Diesel Locomotives

Workchart 3 was derived with the following assumptions:

- A clear line of sight exists between the railway track and the Noise Assessment Location.
- There are two diesel locomotives per train.
- The average train speed is 30 mph.
- Nighttime operations are 0.15 of the 24-hour total.
- The site is not near a grade crossing re-

quiring prolonged use of the train's horn or whistle.

If the situation meets these conditions, proceed to Workchart 3 for an immediate evaluation of diesel locomotive noise.

But:

If any of the conditions is different, make the necessary adjustments listed below and *then* use Workchart 3 for the evaluation.

Figure 14.
Use of Workchart 3 to Evaluate Diesel Locomotive Noise

Railroads – Diesel Locomotives

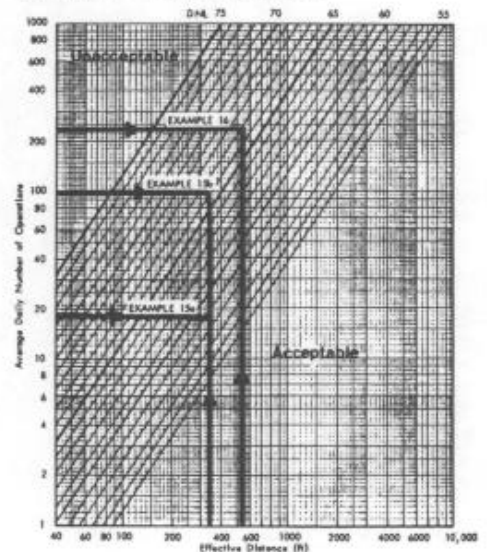

Adjustments for Diesel Locomotives

Number of Locomotives:

If the average number of diesel locomotives per train is not 2, divide the average number by 2. Enter this value in column 9 of Worksheet D.

Example 15a: The distance from NAL number 1 to Railway Number 1 is 339 feet. Two percent of the 35 daily operations occur at night; there is clear line of sight between the tracks and the NAL, and no horns or whistles are used. No information is available on train size or speed, therefore we will assume 2 engines per train and a speed of 30 mph.

Since the percentage of nighttime operations is different from 15 percent, we must adjust the actual number of daily operations, multiplying by 0.50 according to Table 5.

$$0.50 \times 35 = 17.5 = 18$$

Entering Workchart 3 with 18 daily operations and a distance of 339 feet, we find that

the contribution of diesel engine noise is a DNL of 59 dB (see Figure 14).

In order to find the total contribution of the trains to the total DNL, we must also find the noise level produced by the train's cars. Entering Workchart 4 (see Figure 15) with 18 daily operations and a distance of 339 feet, we find the DNL is below 50 on the chart, or more than 10 decibels lower than the noise level produced by the engines. Based on the chart for decibel addition, the combination of the noise from the engines and the cars adds less than 0.5 decibels to the DNL value for the engines alone, 59 dB.

Example 15b: Suppose that a forecast of train operations for Railway 1 indicates that there will still be 35 trains per day, but now 50 percent of the operations will occur at night, the average train will have 4 engines and 75 cars, and the average speed will be 50 mph.

We first find the contribution to DNL made by diesel locomotives by using the following adjustment factors:

- number of engines adjustment: 2
- speed adjustment: 0.60
- day/night adjustment: 2.34

We multiply these adjustments together with the number of trains:

$$2 \times 0.60 \times 2.34 \times 35 = 98$$

Entering Workchart 3 (see Figure 14) with 98 daily operations and a distance of 339

Average Train Speed:

If the average train speed is different from 30 mph, find the appropriate adjustment factor from Table 9 and list in column 10 of Worksheet D.

Table 9

Average Speed (mph)	Speed Adjustment Factor
10	3.00
20	1.50
30	1.00
40	0.75
50	0.60
60	0.50
70	0.43

Horns or Whistles:

If the NAL is perpendicular to any point on the track between the whistle posts for the grade crossing, enter the number 10 in column 11, Worksheet D.

Nighttime Adjustment:

Remember to adjust for nighttime operations, if different from 0.15 of the total, by selecting the appropriate adjustment factor from Table 5 on page 8. Enter in column 12, Worksheet D.

Multiply the adjustment factors together, times the number of diesel trains per day (you have listed this number previously on line 2a, page 1, of Worksheet D, and should enter this number again in column 13) to obtain the adjusted number of trains per day. Enter the adjusted number of diesel trains per day in column 14. Use this value, in conjunction with the distance from the NAL to the track (line 1, page 1, of Worksheet D), to find from Workchart 3 the DNL produced by diesel locomotives. List in column 15 of Worksheet D.

Railway Cars and Rapid Transit Systems

Workchart 4 was derived with the following assumptions:

- A clear line of sight exists between the railway and the NAL.
- There are 50 cars per train.
- The average train speed is 30 mph.
- Nighttime operations are 0.15 of the 24-hour total.
- Rails are welded together.

If the situation meets these conditions, proceed to Workchart 4 for an immediate evaluation of railway car noise. Again, if any of the conditions is different, make the necessary adjustments listed below and then use Workchart 4 for the evaluation.

Figure 15. Use of Workchart 4 to Evaluate Railway Car Noise

Railroads – Cars and Rapid Transit

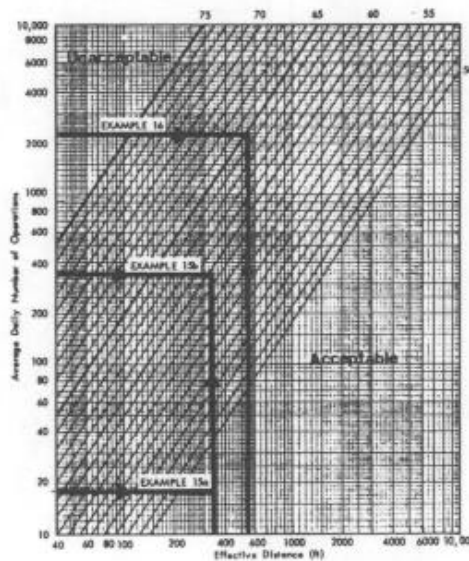

Adjustments for Railway Cars and Rapid Transit Trains

Number of Cars:

Divide the average number of cars by 50 and enter this number in column 18 of Workchart D.

Average Speed:

Make this adjustment, if the average speed is not 30 mph, by selecting the appropriate value from Table 10, entering it in column 19 of Worksheet D.

Table 10

Average Speed (mph)	Speed Adjustment Factor
10	0.11
20	0.44
30	1.00
40	1.78
50	2.78
60	4.00
70	5.44
80	7.11
90	9.00
100	11.11

Bolted Rails:

Enter the number 4 in column 20 of Worksheet D.

Nighttime Adjustment:

Enter the appropriate adjustment factor from Table 5 in column 21 of Worksheet D.

feet, we find that the site has an engine noise contribution to DNL of 66 dB.

We next obtain the adjustment factors for the noise produced by the cars:

- number of cars adjustment: 1.50
- speed adjustment: 2.78
- day/night adjustment: 2.34

Multiplying the adjustment factors times the average daily number of trains:

$$1.5 \times 2.78 \times 2.34 \times 35 = 342$$

Entering Workchart 4 (see Figure 15) with 342 operations and a distance of 339 feet, we find the contribution of the cars to the DNL is 60 dB. Using Table 1 for combining levels, we find that the 6 dB difference between engine noise at 66 and car noise at 60 gives a combined DNL of 67 dB for these trains.

Example 16: The distance from NAL number 2 to Railroad Number 2 is 550 feet; there are 100 operations per day, of which 30 percent occur at night. A clear line of sight exists between the site and the railroad, and no horns or whistles are used nearby. An average train on this track uses 4 engines, has 100 cars, the average speed is 40 miles per hour, and the track has bolted, not welded, rails.

We first find the adjustment factors for the diesel engines:

- number of engines adjustment: 2
- speed adjustment: 0.75
- day/night adjustment: 1.57

Multiplying the adjustments together, times the number of trains:

$$2 \times 0.75 \times 1.57 \times 100 = 236$$

Entering Workchart 3 (see Figure 14) with 236 operations at a distance of 550 feet, we find the DNL contribution from engine noise to be 67 dB.

Next we find the adjustment factors for the railroad cars:

- number of cars adjustment: 2
- speed adjustment: 1.78
- bolted track adjustment: 4
- day/night adjustment: 1.57

Multiplying the adjustments together, times the number of trains:

$$2 \times 1.78 \times 4 \times 1.57 \times 100 = 2236$$

Entering Workchart 4 (see Figure 15) with

(Continued next page)

Figure 16. Sketch Showing Dimensions for Example 16

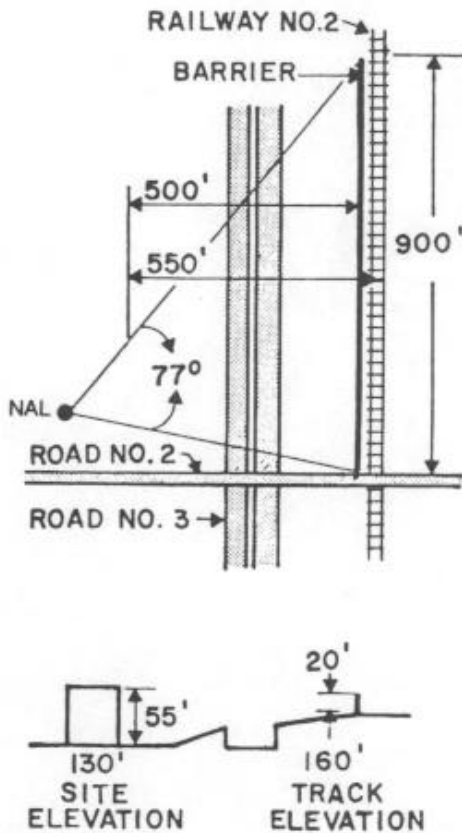

Figure 17. Use of Workchart 6 in Example 16

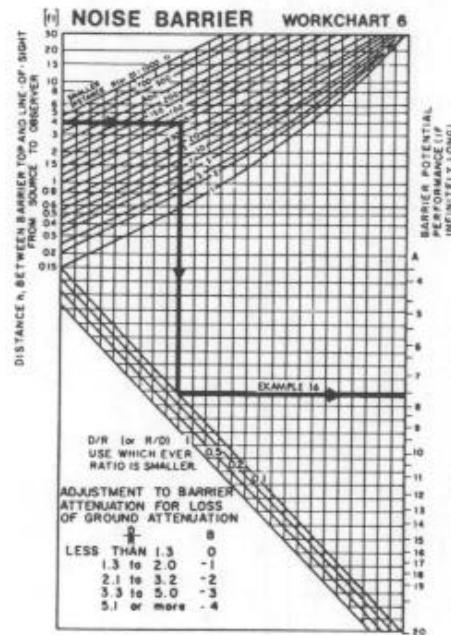
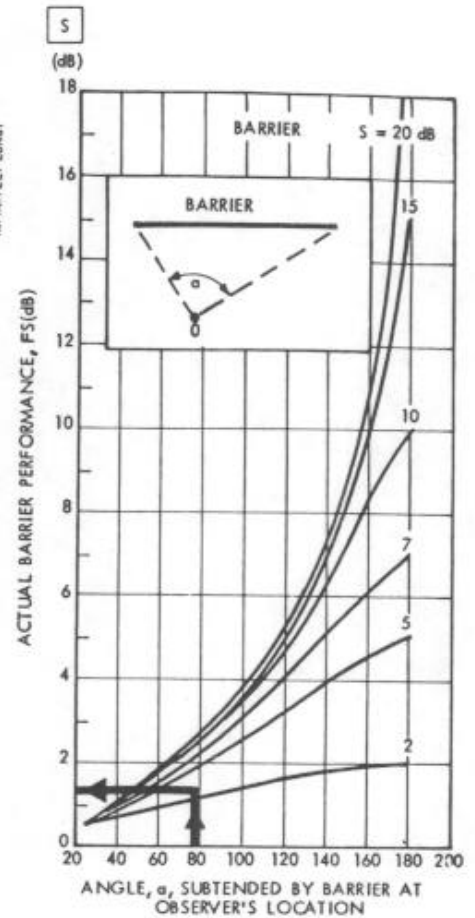

Figure 18. Use of Workchart 7 in Example 16



2236 operations at a distance of 550 feet, we find the DNL contribution from the railroad cars to be 65 dB. Combining the engine sound levels with the car sound levels we find the total DNL from the trains to be 69 dB.

It would be possible to erect a 20-foot noise barrier, running parallel to the track at a distance of 50 feet; it could start at Road Number 2 and run 900 feet north toward the airport, as shown in Figure 16. Both the railroad track and the ground level at the barrier location are at an elevation of 160 feet. Thus, we have the following values with which to calculate the potential reduction in engine noise (using Workchart 5). (Because the distances involved are so unequal, this situation does

not lend itself to direct scaling of the distances.)

$H = 180$ feet (20' above the ground)

$S = 175$ feet (15' above the track, see page 19)

$O = 285$ feet (from Example 11 in the section on roadway noise)

$R' = 50$ feet

$D' = 500$ feet

We find from Worksheet 5 that the values of R and D are no different (within the accuracy of the calculation) from R' and D' , a situation that will always occur when the differences in elevation are so much smaller than the distances from the site to the noise source. The value of h is 4 feet; $R/D = 0.1$

We can now use these numbers to enter Workchart 6 to find the *potential* barrier performance (that is, the barrier adjustment factor that would apply in the case of an infinitely long barrier). Entering Workchart 6 at $h = 4$ feet, with $R/D = 0.1$, we find the basic attenuation of the barrier to be 7.5 dB. However, with $D/R = 10$, we find from the table of loss-of-ground-effect attenuation that we must subtract 4 dB from the 7.5, or a net effect of 3.5 dB. However, the situation is even worse, since the barrier is finite in length.

To find the actual attenuation for this *finite* barrier, we must first find the angle subtended by the barrier to the NAL. Referring to Figure 16, we draw lines from the NAL each end of the barrier. With

References

1. D.E. Bishop, A.P. Hays, "Handbook for Developing Noise Exposure Contours for General Aviation Airports," FAA-AS-75-1, December 1975 (NTIS No. AD-A023429).
2. D.E. Bishop, et al., "Calculation of Day-Night Levels Resulting From Civil Aircraft Operations," BBN Report 3157 for Environmental Protection Agency, March 1976 (NTIS No. PB 266 165).
3. B.A. Kugler, D.E. Commins, W.J. Galloway, "Highway Noise – A Design Guide for Prediction and Control," NCHRP Report 174, Transportation Research Board, National Research Council, 1976.
4. T.J. Schultz, W.J. Galloway, "Noise Assessment Guidelines – Technical Background," Office of Policy Development and Research, U.S. Department of Housing and Urban Development," 1980.
5. M.A. Simpson, "Noise Barrier Design Handbook," FHWA-RD-76-58, Federal Highway Administration, February 1976 (NTIS No. PB 266 378).

a protractor we measure the angle between the two lines to be 77 degrees. Locate the curve on Workchart 7 corresponding to the potential barrier attenuation of 3.5 dB; it lies midway between the two lowest curves (see Figure 18). The point on this curve corresponding to a subtended angle of 77 degrees indicates that the actual barrier performance would be only 1.5 dB. With only 1.5 dB of attenuation, the barrier is clearly not cost-effective. In order to achieve a usable attenuation from the barrier, it would have to be extended beyond the other side of Road Number 2 to obtain a larger subtended angle. This extension, however, would still not be cost-effective unless the height of the barrier were increased substantially.

Summary of Adjustment Factors

Combination of Sound Levels

Table 1

Difference in Sound Level	Add to Larger Level
0	3.0
1	2.5
2	2.1
3	1.8
4	1.5
5	1.2
6	1.0
7	0.8
8	0.6
9	0.5
10	0.4
12	0.3
14	0.2
16	0.1
greater than 16	0.

Aircraft

Table 2 DNL Outside 65 dB Contour

D¹ = distance from 65 dB contour to flight path
D² = distance from site to flight path

D2/D1	DNL dB
1.0	65
1.12	64
1.26	63
1.41	62
1.58	61
1.78	60
2.00	59
2.24	58
2.51	57
2.82	56
3.16	55

Automobile Traffic

Table 3 Stop-and-go

Distance from Site to Stop Sign feet	Automobile Stop-and-go Adjustment Factor
0	0.10
100	0.25
200	0.40
300	0.55
400	0.70
500	0.85
600	1.00

Table 4 Average Traffic Speed

Average Traffic Speed	Adjustment Factor
20 (mph)	0.13
25	0.21
30	0.30
35	0.40
40	0.53
45	0.67
50	0.83
55	1.00
60	1.19
65	1.40
70	1.62

Table 5 Nighttime (applies to all sources)

Nighttime Fraction of ADT	Nighttime Adjustment Factor
0	0.43
0.01	0.46
0.02	0.50
0.05	0.62
0.10	0.81
0.15	1.00
0.20	1.19
0.25	1.38
0.30	1.57
0.35	1.78
0.40	1.96
0.45	2.15
0.50	2.34

Medium Trucks

(less than 26,000 pounds, greater than 10,000 pounds)

Multiply adjusted automobile traffic by 10.

Heavy Trucks

Table 6 Road Gradient

Percent of Adjustment Gradient Factor	
2	1.4
3	1.7
4	2.0
5	2.2
6 or more	2.5

Table 7 Average Speed

Average Traffic Speed (mph)	Truck Speed Adjustment Factor
50 or less	0.81
55	1.00
60	1.17
65	1.38

Table 8 Stop-and-go

Heavy Truck Traffic Volume per Day	Heavy Truck Stop-and-Go Adjustment Factor
Less than 1200	1.8
1201 to 2400	2.0
2401 to 4800	2.3
4801 to 9600	2.8
9601 to 19,200	3.8
More than 19,200	4.5

Railroads - Diesel Engines

Number of Engines per Train

The number of engines divided by 2.

Table 9 Average Train Speed

Average Speed (mph)	Speed Adjustment Factor
10	3.00
20	1.50
30	1.00
40	0.75
50	0.60
60	0.50
70	0.43

Whistles or horns

Multiply number of trains by 10.

Railroads - Cars and Rapid Transit

Numbers of cars.

Number of cars per train divided by 50.

Table 10 Average Train Speed

Average Speed (mph)	Speed Adjustment Factor
10	0.11
20	0.44
30	1.00
40	1.78
50	2.78
60	4.00
70	5.44
80	7.11
90	9.00
100	11.11

Bolted Rails

Multiply number of trains by 4.

Whistles or Horns

Multiply number of trains by 100.

**Workchart 1
Autos (55 mph)**

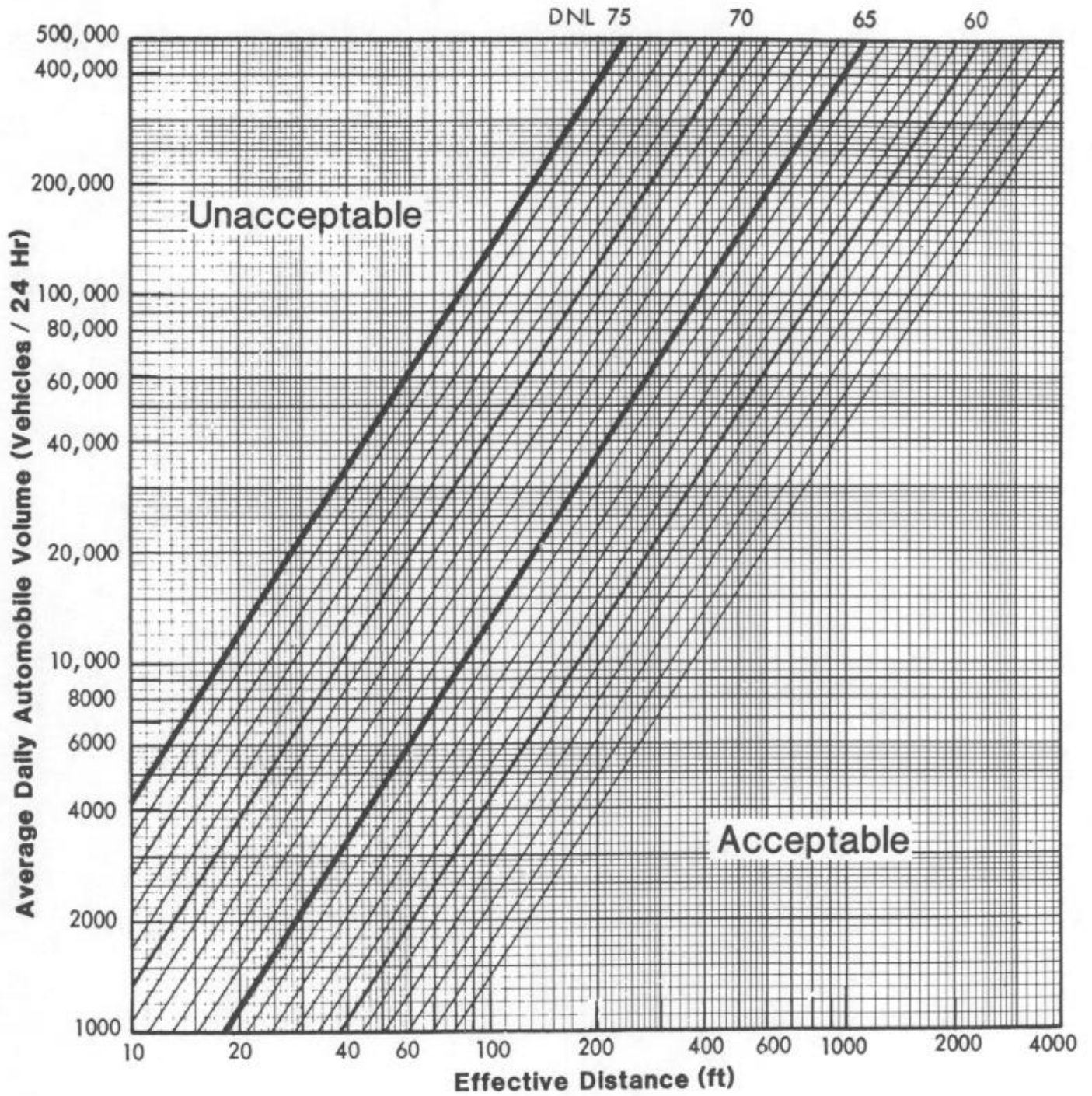

**Workchart 2
Heavy Trucks (55 mph)**

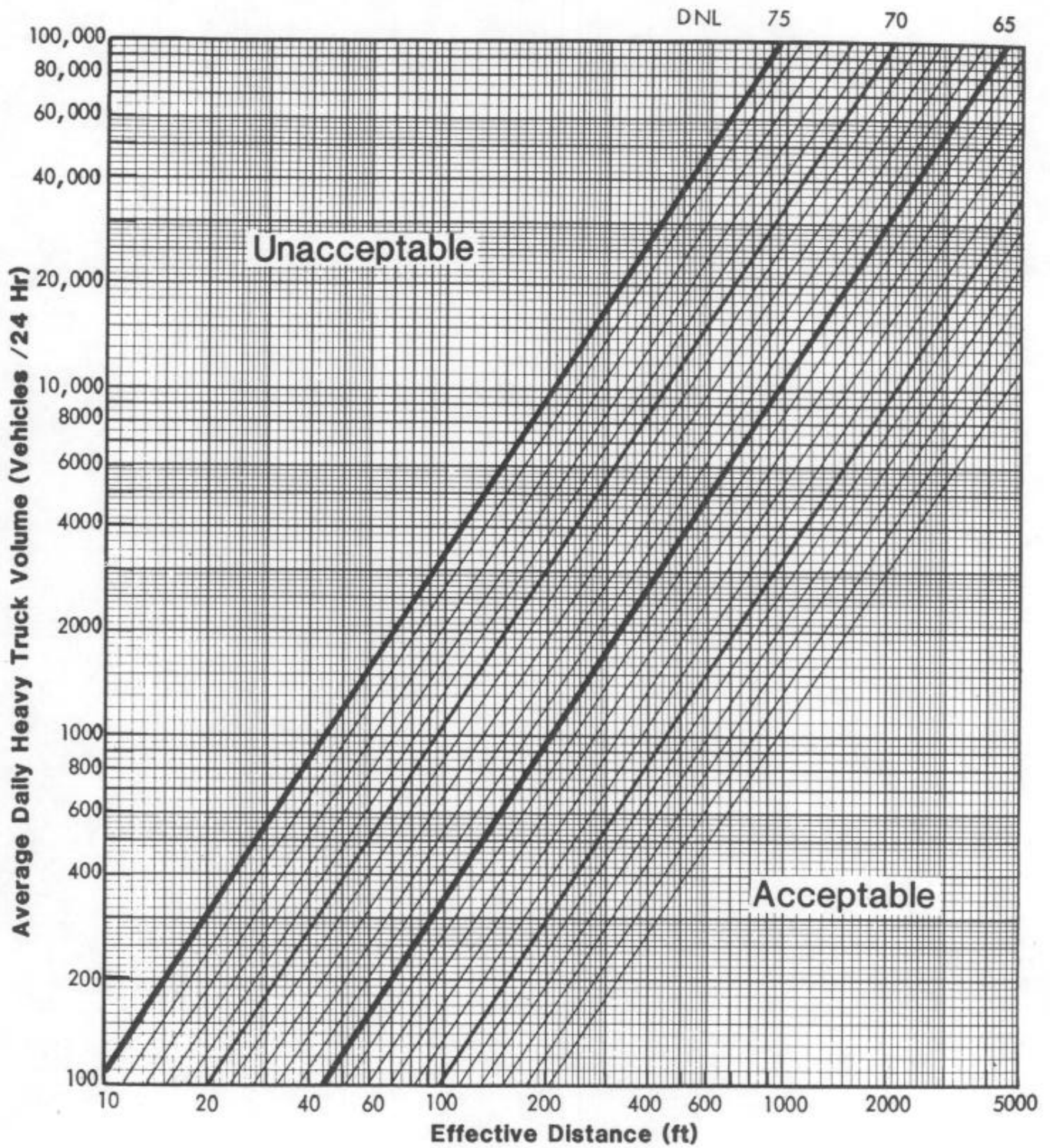

Workchart 3
Railroads - Diesel Locomotives

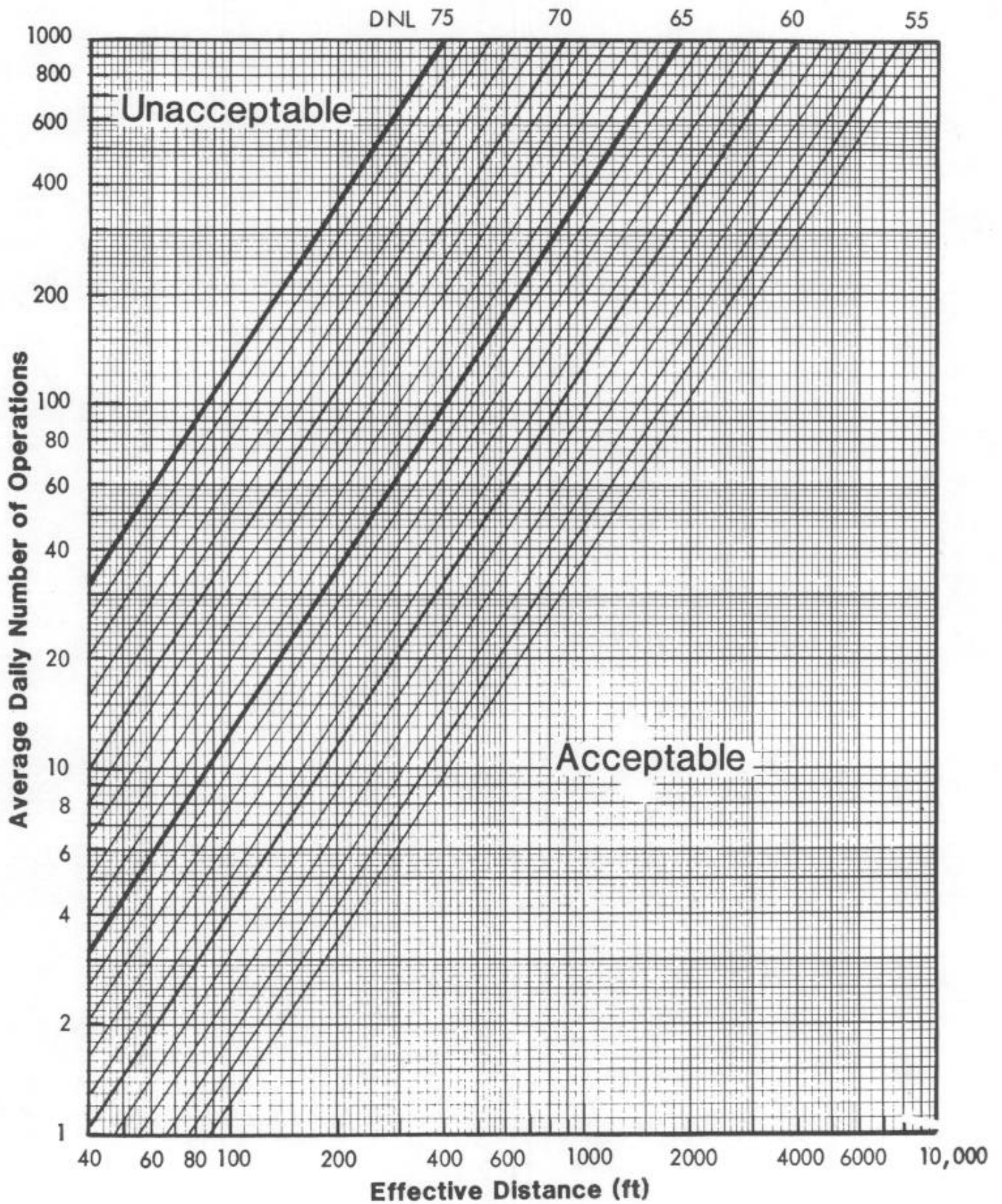

**Workchart 4
Railroads - Cars and Rapid Transit**

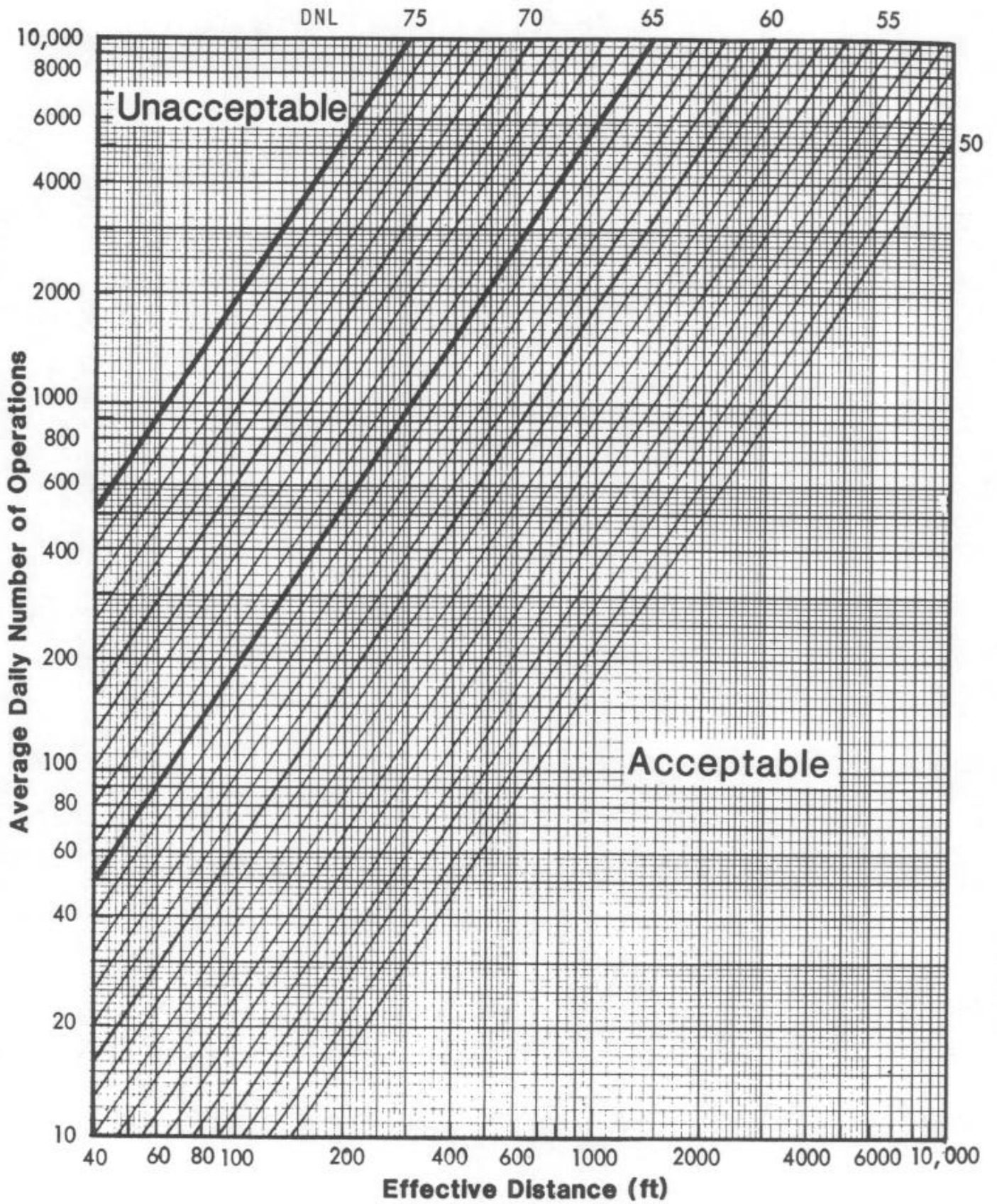

Workchart 5 Noise Barrier

To find R, D and h from Site Elevations and Distances

Fill out the following worksheet (all quantities are in feet):

Enter the values for:

H = _____ R' = _____

S = _____ D' = _____

O = _____

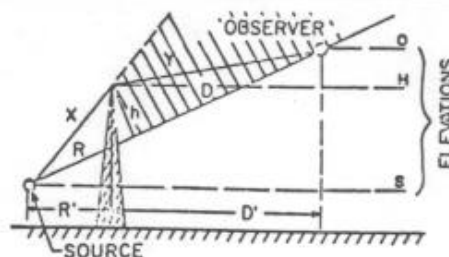

- | | |
|---|------------------------------|
| 1. Elevation of barrier top minus elevation of source | [H] - [S] = [1] |
| 2. Elevation of observer minus elevation of source | [O] - [S] = [2] |
| 3. Map distance between source and observer (R' + D') | [3] |
| 4. Map distance between barrier and source (R') | [4] |
| 5. Line 2 divided by line 3 | [2] ÷ [3] = [5] |
| 6. Square the quantity on line 5 (i.e., multiply it by itself); always positive | [5] × [5] = [6] |
| 7. 40% of line 6 | [0.4] × [6] = [7] |
| 8. One minus line 7 | [1.0] - [7] = [8] |
| 9. Line 5 times line 4 (will be negative if line 2 is negative) | [5] × [4] = [9] |
| 10. Line 1 minus line 9 | [1] - [9] = [10] |
| 11. Line 10 times line 8 | [10] × [8] = [11] = h |
| 12. Line 5 times line 10 | [5] × [10] = [12] |
| 13. Line 4 divided by line 8 | [4] ÷ [8] = [13] |
| 14. Line 13 plus line 12 | [13] + [12] = [14] = R |
| 15. Line 3 minus line 4 | [3] - [4] = [15] |
| 16. Line 15 divided by line 8 | [15] ÷ [8] = [16] |
| 17. Line 16 minus line 12 | [16] - [12] = [17] = D |

[Note: the value on line 2 may be negative, in which case so will the values on lines 5, 9, and 12; line 1 may also be negative. Remember, then, in

lines 10, 14, and 17, that adding a negative number is the same as subtracting:
 $x + (-y) = x - y$. And subtracting a negative number is like adding: $x - (-y) = x + y$.

Round off R and D to nearest integer, h to one decimal place.

Workchart 6 Noise Barrier

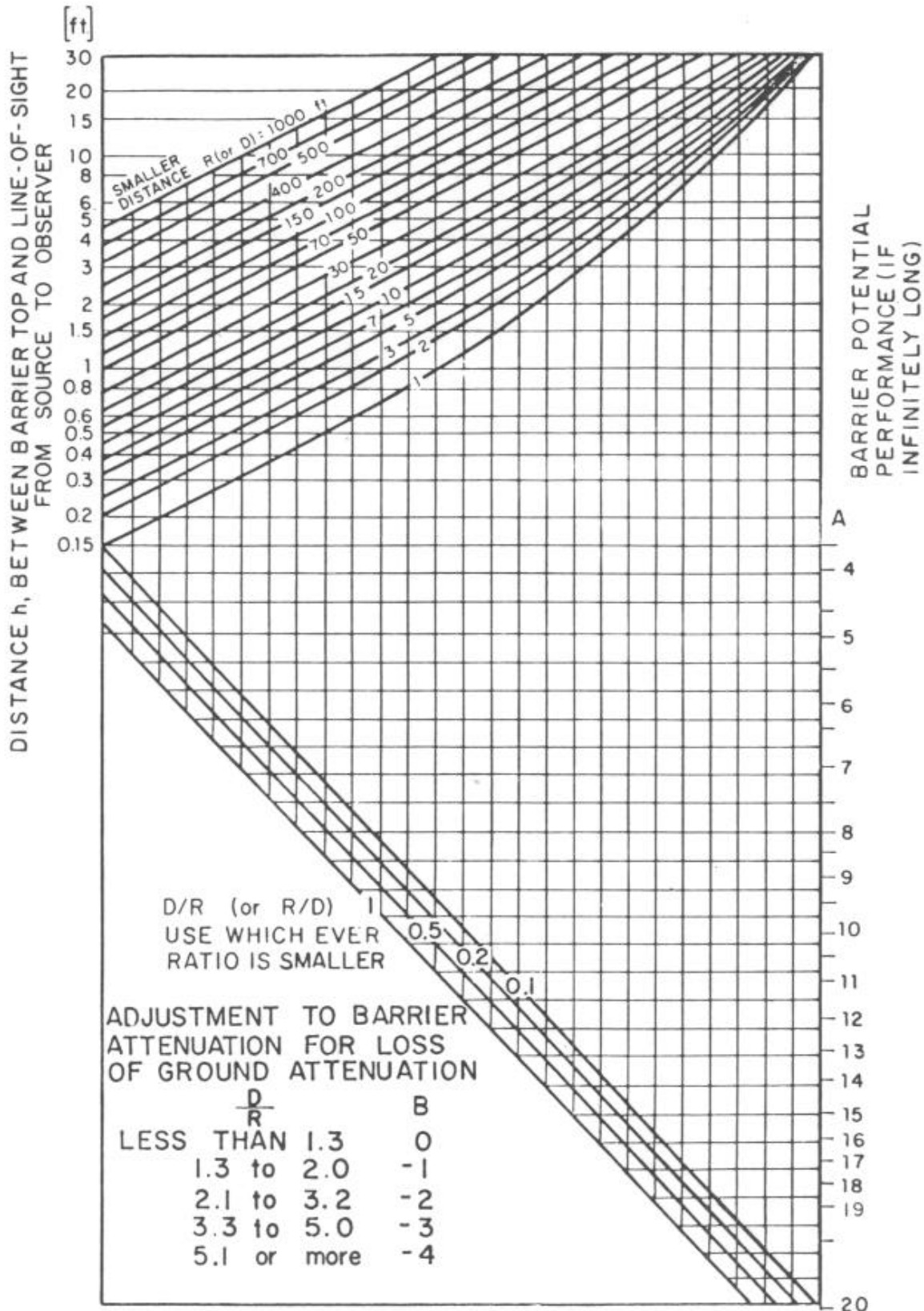

Workchart 7

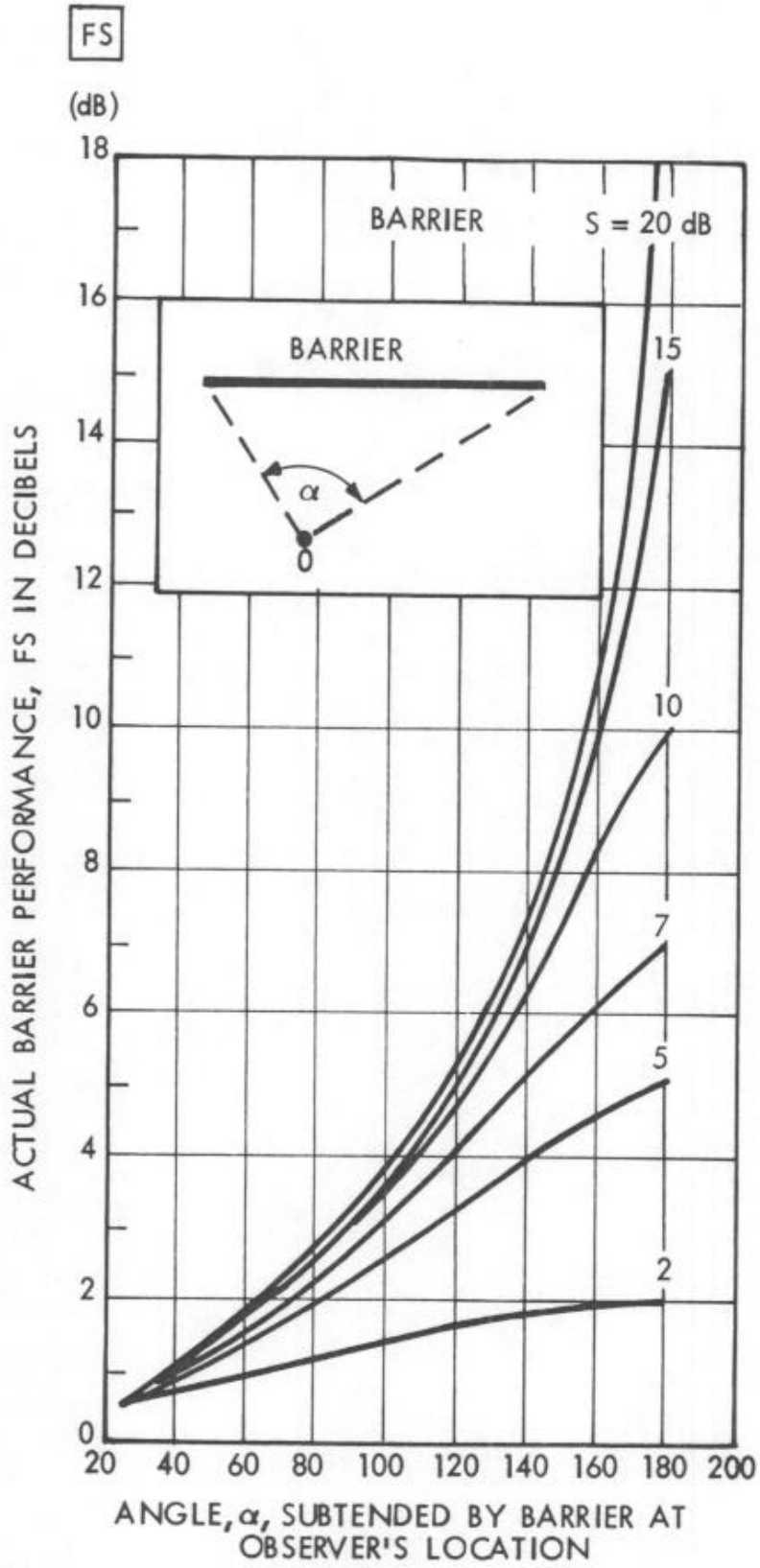

Correction to be applied to barrier potential in order to find the actual performance of the barrier of the same construction but of finite length.

**Worksheet A
Site Evaluation**

Noise Assessment Guidelines

Site Location _____

Program _____

Project Name _____

Locality _____

File Number _____

Sponsor's Name _____

Phone _____

Street Address _____

City, State _____

	Acceptability Category	DNL	Predicted for Operations in Year
1. Roadway Noise	_____	_____	_____
2. Aircraft Noise	_____	_____	_____
3. Railway Noise	_____	_____	_____

Value of DNL for all noise sources: (see page 3 for combination procedure) _____

Final Site Evaluation (circle one)

Acceptable

Normally Unacceptable

Unacceptable

Signature _____

Date _____

Clip this worksheet to the top of a package containing Worksheets B-E and Workcharts 1-7 that are used in the site evaluations

**Worksheet B
Aircraft Noise**

List all airports within 15 miles of the site:

- 1. _____
- 2. _____
- 3. _____

Necessary Information:

Airport 1 Airport 2 Airport 3

- 1. Are DNL, NEF or CNR contours available?
(yes/no) _____
- 2. Any supersonic aircraft operations?
(yes/no) _____
- 3. Estimating approximate contours from Figure 3:
 - a. number of nighttime jet operations _____
 - b. number of daytime jet operations _____
 - c. effective number of operations
(10 times a + b) _____
 - d. distance A for 65 dB _____
 - 70dB _____
 - 75 dB _____
 - e. distance B for 65 dB _____
 - 70 dB _____
 - 75 dB _____
- 4. Estimating DNL from Table 2:
 - a. distance from 65 dB contour to
flight path, D^1 _____
 - b. distance from NAL to flight
path, D^2 _____
 - c. D^2 divided by D^1 _____
 - d. DNL _____
- 5. Operations projected for what year? _____
- 6. Total DNL from all airports _____

Signed _____

Date _____

List all major roads within 1000 feet of the site:

1. _____
2. _____
3. _____
4. _____

Necessary Information	Road 1	Road 2	Road 3	Road 4
1. Distance in feet from the NAL to the edge of the road				
a. nearest lane	_____	_____	_____	_____
b. farthest lane	_____	_____	_____	_____
c. average (effective distance)	_____	_____	_____	_____
2. Distance to stop sign	_____	_____	_____	_____
3. Road gradient in percent	_____	_____	_____	_____
4. Average speed in mph				
a. Automobiles	_____	_____	_____	_____
b. heavy trucks - uphill	_____	_____	_____	_____
c. heavy trucks - downhill	_____	_____	_____	_____
5. 24 hour average number of automobiles and medium trucks in both directions (ADT)				
a. automobiles	_____	_____	_____	_____
b. medium trucks	_____	_____	_____	_____
c. effective ADT (a + (10xb))	_____	_____	_____	_____
6. 24 hour average number of heavy trucks				
a. uphill	_____	_____	_____	_____
b. downhill	_____	_____	_____	_____
c. total	_____	_____	_____	_____
7. Fraction of nighttime traffic (10 p.m. to 7 a.m.)	_____	_____	_____	_____
8. Traffic projected for what year?	_____	_____	_____	_____

Adjustments for Automobile Traffic

	9 Stop and-go Table 3	10 Average Speed Table 4	11 Night- Time Table 5	12 Auto ADT (line 5c)	13 Adjusted Auto ADT	14 DNL (Workchart 1)	15 Barrier Attenuation	16 Partial DNL
Road No. 1	_____ X _____	_____ X _____	_____ X _____	_____ X _____	= _____	_____	- _____	= _____
Road No. 2	_____ X _____	_____ X _____	_____ X _____	_____ X _____	= _____	_____	- _____	= _____
Road No. 3	_____ X _____	_____ X _____	_____ X _____	_____ X _____	= _____	_____	- _____	= _____
Road No. 4	_____ X _____	_____ X _____	_____ X _____	_____ X _____	= _____	_____	- _____	= _____

Adjustments for Heavy Truck Traffic

	17 Gradient Table 6	18 Average Speed Table 7	19 Truck ADT 2	20	21	22 Stop and-go Table 8	23 Night- Time Table 5	24 Adjusted Truck ADT	25 DNL (Work- chart 2)	26 Barrier Attn.	27 Partial DNL	
Uphill	_____ X _____	_____ X _____	_____ X _____	_____	_____	_____	_____	_____	_____	_____	_____	
Road No. 1	_____	_____	_____	_____	_____	Add _____	X _____	X _____	= _____	_____	- _____	= _____
Downhill	_____	_____ X _____	_____	_____	_____	_____	_____	_____	_____	_____	_____	
Uphill	_____ X _____	_____ X _____	_____ X _____	_____	_____	_____	_____	_____	_____	_____	_____	
Road No. 2	_____	_____	_____	_____	_____	Add _____	X _____	X _____	= _____	_____	- _____	= _____
Downhill	_____	_____ X _____	_____	_____	_____	_____	_____	_____	_____	_____	_____	
Uphill	_____ X _____	_____ X _____	_____ X _____	_____	_____	_____	_____	_____	_____	_____	_____	
Road No. 3	_____	_____	_____	_____	_____	Add _____	X _____	X _____	= _____	_____	- _____	= _____
Downhill	_____	_____ X _____	_____	_____	_____	_____	_____	_____	_____	_____	_____	
Uphill	_____ X _____	_____ X _____	_____ X _____	_____	_____	_____	_____	_____	_____	_____	_____	
Road No. 4	_____	_____	_____	_____	_____	Add _____	X _____	X _____	= _____	_____	- _____	= _____
Downhill	_____	_____ X _____	_____	_____	_____	_____	_____	_____	_____	_____	_____	

Combined Automobile & Heavy Truck DNL

Road No. 1 _____	Road No. 2 _____	Road No. 3 _____	Road No. 4 _____	Total DNL for All Roads _____
------------------	------------------	------------------	------------------	-------------------------------

Signature _____ Date _____

List All Railways within 3000 feet of the site:

- 1. _____
- 2. _____
- 3. _____

Necessary Information:

Railway No. 1 Railway No. 2 Railway No. 3

- 1. Distance in feet from the NAL to the railway track: _____
- 2. Number of trains in 24 hours:
 - a. diesel _____
 - b. electrified _____
- 3. Fraction of operations occurring at night (10 p.m. – 7 a.m.): _____
- 4. Number of diesel locomotives per train: _____
- 5. Number of rail cars per train:
 - a. diesel trains _____
 - b. electrified trains _____
- 6. Average train speed: _____
- 7. Is track welded or bolted? _____
- 8. Are whistles or horns required for grade crossings? _____

Adjustments for Diesel Locomotives

	9 No. of Locomotives 2	10 Average Speed Table 9	11 Horns (enter 10)	12 Night- time Table 5	13 No. of Trains (line 2a)	14 Adj. No. of Opns.	15 DNL Workchart 3	16 Barrier Attn.	17 Partial DNL
Railway No. 1	_____ X	_____ X	_____ X	_____ X	_____ X	= _____	_____ - _____	= _____	
Railway No. 2	_____ X	_____ X	_____ X	_____ X	_____ X	= _____	_____ - _____	= _____	
Railway No. 3	_____ X	_____ X	_____ X	_____ X	_____ X	= _____	_____ - _____	= _____	

Adjustments for Railway Cars or Rapid Transit Trains

	18 Number of cars 50	19 Average Speed Table 10	20 Bolted Rails (enter 4)	21 Night- time Table 5	22 No. of Trains (Line 2a or 2b)	23 Adj. No. of Opns.	24 DNL Work- chart 4	25 Barrier Attn.	26 Partial DNL
Railway No. 1	_____ X	_____ X	_____ X	_____ X	_____ X	= _____	_____ - _____	= _____	
Railway No. 2	_____ X	_____ X	_____ X	_____ X	_____ X	= _____	_____ - _____	= _____	
Railway No. 3	_____ X	_____ X	_____ X	_____ X	_____ X	= _____	_____ - _____	= _____	

Combined Locomotive and Railway Car DNL

Railway No. 1 _____ Railway No. 2 _____ Railway No. 3 _____ Total DNL for all Railways _____

Signature _____ Date _____