



U.S. Department  
of Transportation  
**Federal Highway**

**Administration**

400 Seventh St., S.W.  
Washington, D.C.  
20590

Refer to: HSA-10/WZ-80

Mr. Henry A. Ross  
Director of Sales and Marketing  
United Rentals Highway Technologies  
880 North Addison Road  
Villa Park, IL 60181-7050

Dear Mr. Ross:

Thank you for your letter of March 6 requesting Federal Highway Administration (FHWA) acceptance of your revised Safety Cade Type I and Type II barricade as a crashworthy traffic control device for use in work zones on the National Highway System (NHS). Accompanying your letter were drawings of the old and new designs. You requested that we find your company's revised Safety Cade barricade acceptable for use on the NHS under the provisions of National Cooperative Highway Research Program (NCHRP) Report 350 "Recommended Procedures for the Safety Performance Evaluation of Highway Features."

We found the Type I and Type II SafetyCade barricades and vertical panels acceptable for use on June 19, 1997, with acceptance letter WZ-1. The modified SafetyCade Vertical Panel was found acceptable on June 30, 1999, in acceptance letter WZ-15. The modifications included a larger panel and the redesign of the warning light attachments. The lightweight warning lights with their batteries are now mounted in the top of the panel. Your specific request is for a new Type I and Type II SafetyCade barricade that uses the same light receptacle at the top of the barricade. The redesigned barricade has a mass of 15.4 kg (34 pounds) without the light or ballast. With the light the mass is 16.8 kg (37 pounds). Typically, approximately 10 kg (23 pounds) of sand are used to ballast the device.

#### **Introduction and Testing**

The FHWA guidance on crash testing of work zone traffic control devices is contained in two memoranda. The first, dated July 25, 1997, titled "INFORMATION: Identifying Acceptable Highway Safety Features," established four categories of work zone devices: Category I devices were those lightweight devices which could be self-certified by the vendor, Category II devices were other lightweight devices which needed individual crash testing, Category III devices were barriers and other fixed or massive devices also needing crash testing, and Category IV devices were trailer mounted lighted signs, arrow panels, etc. The second guidance memorandum was issued on August 28, 1998, and is titled "INFORMATION: Crash Tested Work Zone Traffic Control Devices." This later memorandum lists devices that are acceptable under Categories I, II, and III.

The new extended panel SafetyCade Vertical Panel houses the entire warning light assembly in a special receptacle in the top of the barricade whereas the earlier design had a separate compartment for the warning light battery below bumper height. The same design feature has been incorporated into the Type I and Type II barricades.

The test article, (vertical panel, as accepted in WZ-15) was outfitted with the “ToughLite 2000 L.E.D. Warning Light” and two optional sand-filled ballast boots locked onto the barricade leg. The test article mass, including the warning light, was 14.1 kg. The two sand-filled boots had a mass of 11.4 kg each. The overall height is 1296 mm and is 419 mm wide.

Full-scale automobile testing was conducted on your company’s vertical panel. Two examples of the device were tested in tandem, one head-on and the next at 90 degrees, as called for in our guidance memorandum. The impact speed with the first device was 100.4 km/hr and 97.0 km/hr with the second. The velocity changes were 3.4 km/r and 3.3 km/hr (both approximately 1 m/s, which is well within the 5 m/s maximum) after the successive impacts. During the test there was no damage to the windshield, and only minor damage occurred to the test vehicle’s hood. There was no occupant compartment intrusion or deformation observed, nor did any test article debris show potential for penetrating the occupant compartment.

### **Findings**

The results of the testing met the FHWA requirements. The prior testing of the SafetyCade Type I and Type II barricades also performed acceptably. We concur in your assertion that the modification of the Type I and Type II barricade will perform in an acceptable manner as did the vertical panel. Therefore, the SafetyCade Type I and Type II Barricades discussed above and shown in the enclosed drawings for reference are acceptable for use as Test Level 3 devices on the NHS under the range of conditions tested, when proposed by a State.

Please note the following standard provisions which apply to FHWA letters of acceptance:

- Our acceptance is limited to the crashworthiness characteristics of the devices and does not cover their structural features, nor conformity with the Manual on Uniform Traffic Control Devices.
- Any changes that may adversely influence the crashworthiness of the device will require a new acceptance letter.
- Should the FHWA discover that the qualification testing was flawed, that in-service performance reveals unacceptable safety problems, or that the device being marketed is significantly different from the version that was crash tested, it reserves the right to modify or revoke its acceptance.
- You will be expected to supply potential users with sufficient information on design and installation requirements to ensure proper performance.
- You will be expected to certify to potential users that the hardware furnished has essentially the same chemistry, mechanical properties, and geometry as that submitted for acceptance, and that they will meet the crashworthiness requirements of FHWA and NCHRP Report 350.
- To prevent misunderstanding by others, this letter of acceptance, designated as number WZ-80 shall not be reproduced except in full. This letter, and the test documentation upon which this letter is based, is public information. All such letters and documentation may be reviewed at our office upon request.
- SafetyCade barricades may include patented components and if so are considered

"proprietary." The use of proprietary work zone traffic control devices in Federal-aid projects is generally of a temporary nature. They are selected by the contractor for use as needed and removed upon completion of the project. Under such conditions they can be presumed to meet requirement "a" given below for the use of proprietary products on Federal-aid projects. On the other hand, if proprietary devices are specified for use on Federal-aid projects, except exempt, non-NHS projects, they: (a) must be supplied through competitive bidding with equally suitable unpatented items; (b) the highway agency must certify that they are essential for synchronization with existing highway facilities or that no equally suitable alternative exists or; (c) they must be used for research or for a distinctive type of construction on relatively short sections of road for experimental purposes. Our regulations concerning proprietary products are contained in Title 23, Code of Federal Regulations, Section 635.411, a copy of which is enclosed.

Sincerely yours,

Frederick G. Wright, Jr.  
Program Manager, Safety

Enclosure

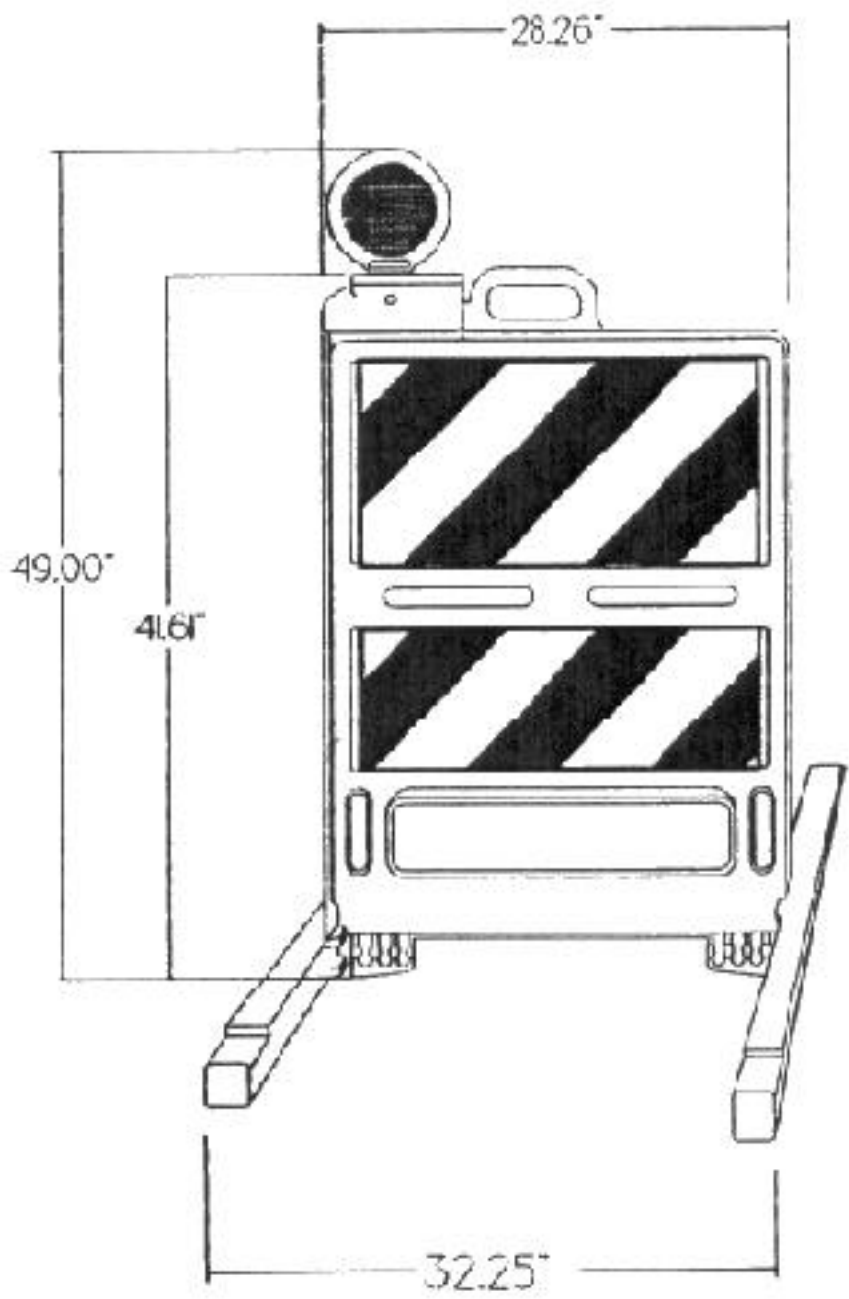

34" INCLUDING  
DETENT HARDWARE

V

WZ 15

WZ-1

