

July 30, 2004

Refer to: HSA-10/WZ-186

Mr. Chad A. LaCivita
Vice President of Operations
Eastern Molding International, LLC
P.O. Box 311
1 Elizabeth Street
Batavia, New York 14020

Dear Mr. LaCivita:

Thank you for your letter of May 3, 2004, requesting Federal Highway Administration (FHWA) acceptance of your company's 42 inch tall Channelizer Cones with warning lights as crashworthy traffic control devices for use in work zones on the National Highway System (NHS). Accompanying your letter were reports of crash testing conducted by Engineering Code Services and video of the tests. You requested that we find these devices acceptable for use on the NHS under the provisions of National Cooperative Highway Research Program (NCHRP) Report 350 "Recommended Procedures for the Safety Performance Evaluation of Highway Features."

Introduction

The FHWA guidance on crash testing of work zone traffic control devices is contained in two memoranda. The first, dated July 25, 1997, titled "INFORMATION: Identifying Acceptable Highway Safety Features," established four categories of work zone devices: Category I devices are those lightweight devices which are to be self-certified by the vendor, Category II devices are other lightweight devices which need individual crash testing but with reduced instrumentation, Category III devices are barriers and other fixed or heavy devices also needing crash testing with normal instrumentation, and Category IV devices are trailer mounted lighted signs, arrow panels, etc. for which crash testing requirements have not yet been established. The second guidance memorandum was issued on August 28, 1998, and is titled "INFORMATION: Crash Tested Work Zone Traffic Control Devices." This later memorandum lists devices that are acceptable under Categories I, II, and III.

A brief description of the devices follows:

The Highway Safety Tech 42" Channelizer Cone is molded of low-density polyethylene weighing 2.8 pounds. Its base diameter is a nominal 7.7 inches, tapering to 4 inches nominal at the top. The top of the handle measures 49.8 inches from the ground, while the top of the reflective sheeting panels is 42.1 inches. The tested devices also had Collt Incase Type A&C warning lights with 2 Rayovac 6 volt batteries enclosed in a light case and affixed to the cone with a 1/2 inch diameter, 3-3/4 inch long bolt and cupped washer/bolt protector. The lights, including batteries, weighed 4.1 pounds. Each tested cone was weighted with a 16-pound drop over rubber base.

Testing

Full-scale automobile testing was conducted on your company's devices. Two stand-alone examples of the device were tested in tandem, one head-on and the next placed downstream turned at 90 degrees, as called for in our guidance memoranda. The vehicle (1987 Toyota Camry, weighing 2734 pounds) impacted both devices at approximately 62 mph. Each channelizer separated from the rubber base and impacted the vehicle's bumper, grille, and hood. While the warning light cases were cracked, the lenses and battery packs remained intact and attached to the top of the channelizer.

Although the test vehicle did not conform to the NCHRP Report 350 specifications for the 820C vehicle, it appeared to be adequate for this test as the principal object was to see if any part of the test article would impact and damage the windshield. The points at which the warning lights hit the hood were well away from the windshield and would not have posed a threat on an 820C vehicle.

Findings

Damage was limited to cosmetic scrapes and minor dents, with no damage to the windshield. The results of the testing met the FHWA requirements and, therefore, the devices described above and detailed in the enclosed drawings are acceptable for use on the NHS under the range of conditions tested, when proposed by a State.

Please note the following standard provisions that apply to the FHWA letters of acceptance:

- Our acceptance is limited to the crashworthiness characteristics of the devices and does not cover their structural features, nor conformity with the Manual on Uniform Traffic Control Devices.
- Any changes that may adversely influence the crashworthiness of the device will require a new acceptance letter.
- Should the FHWA discover that the qualification testing was flawed, that in-service performance reveals unacceptable safety problems, or that the device being marketed is significantly different from the version that was crash tested, it reserves the right to modify or revoke its acceptance.
- You will be expected to supply potential users with sufficient information on design and installation requirements to ensure proper performance.
- You will be expected to certify to potential users that the hardware furnished has essentially the same chemistry, mechanical properties, and geometry as that submitted for acceptance, and that they will meet the crashworthiness requirements of the FHWA and the NCHRP Report 350.
- To prevent misunderstanding by others, this letter of acceptance, designated as number WZ-186 shall not be reproduced except in full. This letter, and the test documentation upon which this letter is based, is public information. All such letters and documentation may be reviewed at our office upon request.

- This acceptance letter shall not be construed as authorization or consent by the FHWA to use, manufacture, or sell any patented device for which the applicant is not the patent holder. The acceptance letter is limited to the crashworthiness characteristics of the candidate device, and the FHWA is neither prepared nor required to become involved in issues concerning patent law. Patent issues, if any, are to be resolved by the applicant.

Sincerely yours,

/Original Signed by/

John R. Baxter, P.E.
Director, Office of Safety Design
Office of Safety

Enclosures

FHWA:HSA-10:NArtimovich:tb:x61331:7/28/04

File: h://directory folder/nartimovich/WZ186-EasternMoldingFIN

cc: HSA-10 (Reader, HSA-1; Chron File, HSA-10;
N. Artimovich, HSA-10)

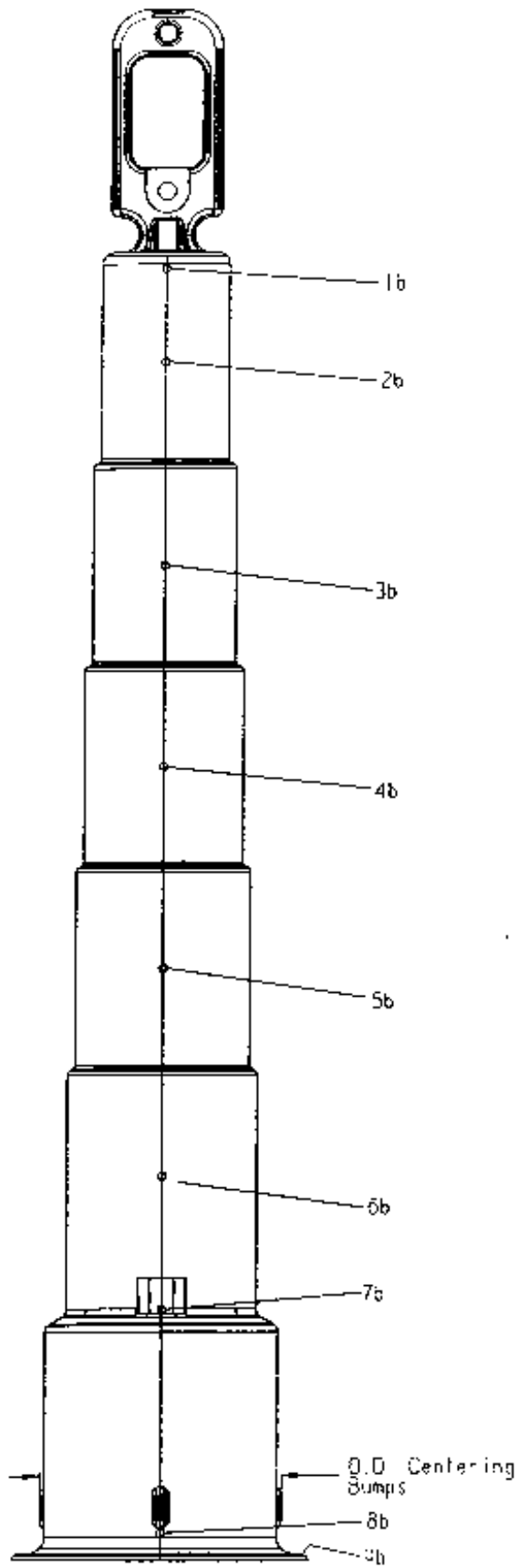

REV.	DESCRIPTION	DATE
1	CONE POCKETS REPLACED BY CIRCULAR POCKET	FEB. 05/03

TOP VIEW

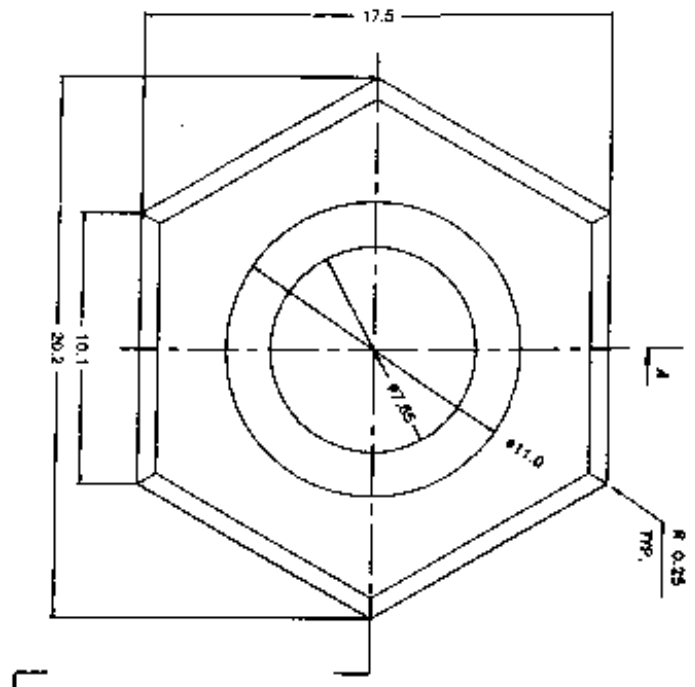

SECTION A-A

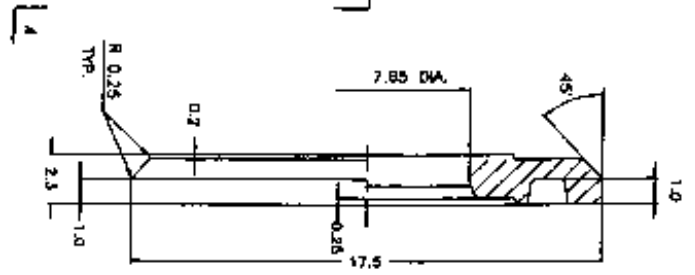

BOTTOM VIEW

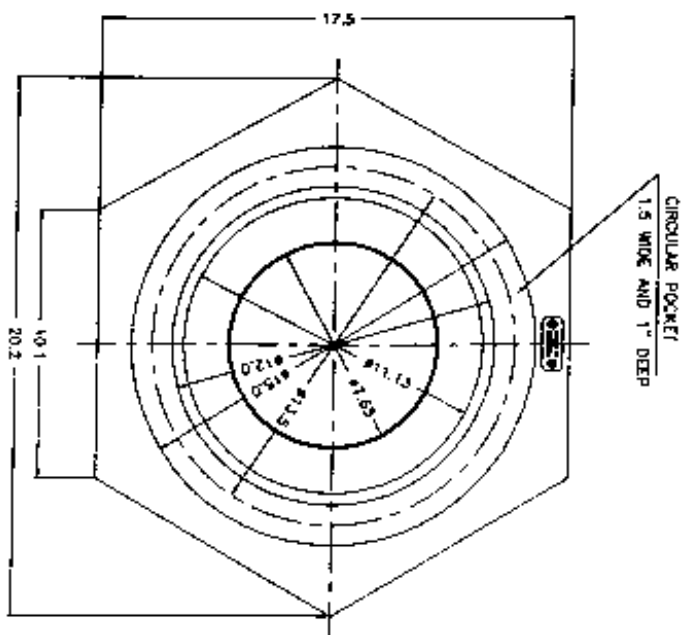

THIS DRAWING IS THE PROPERTY OF GNR TECHNOLOGIES INC. AND MAY NOT BE DISSEMINATED, REPRODUCED, COPIED, OR OTHERWISE USED FOR ANY PURPOSES WITHOUT WRITTEN PERMISSION FROM GNR TECHNOLOGIES INC.

UNLESS OTHERWISE SPECIFIED DIMENSIONS ARE IN INCHES DECIMALS FRACTIONS 1/16" 1/8" 1/4" 3/8" 1/2"		GNR TECHNOLOGIES INC. HEXAGONAL RUBBER BASE QUOTE: PST16887.6 DRAWN: S. JOWASE CHECKED: S. JOWASE DATE: MAY 01/03 DATE: MAY 01/03 MATERIAL: RUBBER SEAL: 1-6 PARTIAL: RUBBER SCALE: 1:1 SHEET: 1 OF 1 DATE:	
---	--	--	--