

March 8, 2004

Refer to: HSA-10

Mr. Peter Connors
Remcon Plastics, Incorporated
208 Chestnut Street
Reading, Pennsylvania 19602-1809

Dear Mr. Connors:

Thank you for your letter of January 26, 2004, requesting Federal Highway Administration's (FHWA) acceptance of your company's Type I and Type II Barricades as crashworthy traffic control devices for use in work zones on the National Highway System (NHS). Accompanying your letter were drawings of the device and a comparison to generic crash-tested barricades. You requested that we find your company's barricades acceptable for use on the NHS under the provisions of National Cooperative Highway Research Program (NCHRP) Report 350 "Recommended Procedures for the Safety Performance Evaluation of Highway Features."

Introduction

The FHWA guidance on crash testing of work zone traffic control devices is contained in two memoranda. The first, dated July 25, 1997, titled "INFORMATION: Identifying Acceptable Highway Safety Features," established four categories of work zone devices: Category I devices are those lightweight devices which are to be self-certified by the vendor, Category II devices are other lightweight devices which need individual crash testing but with reduced instrumentation, Category III devices are barriers and other fixed or heavy devices also needing crash testing with normal instrumentation, and Category IV devices are trailer mounted lighted signs, arrow panels, etc. for which crash testing requirements have not yet been established. The second guidance memorandum was issued on August 28, 1998, and is titled "INFORMATION: Crash Tested Work Zone Traffic Control Devices." This later memorandum lists devices that are acceptable under Categories I, II, and III.

A brief description of the devices follows:

The Remcon Type I and Type II barricades are assembled from high density polyethylene parts. It can be fabricated using one or two 12x24 or 8x24 panels on each side which are attached to the legs using 20-1/4x1.00 steel bolts and hex nuts. The legs are each 44.5 inches long, and are joined at the top using 13-1/2x1.5 stainless steel carriage bolts and hex nuts. The panels are manufactured to hold interchangeable

transparent diagonal striped “lenses” with retroreflective sheeting affixed to the face of the panels. The total assembled weight using a pair of 12x24 panels above, a pair of 8x24 panels below, and a pair of 3x24 panels at the base for stability and handicap detection, is 21 pounds. The height to the top of the legs when the barricade is deployed is 40.0 inches. The height to the top of the upper panel is 36.125 inches.

Findings

The Remcon high-density polyethylene plastic Type I and II barricades are similar in size, weight, and materials to other crashworthy barricades. They can be expected to perform as well as the generic steel leg barricades found acceptable in the FHWA acceptance letter WZ-85 dated November 15, 2001. Therefore, the devices described above and detailed in the enclosed drawings are acceptable for use on the NHS under the range of conditions that the generic barricades were tested, when proposed by a State. **NOTE: This acceptance is for the barricades plus reflective sheeting and striping lens (and properly located ballast, if needed), only. If these are to be used with warning lights they should be crash tested with the type of light(s) they will be used with.**

Please note the following standard provisions that apply to the FHWA letters of acceptance:

- Our acceptance is limited to the crashworthiness characteristics of the devices and does not cover their structural features, nor conformity with the Manual on Uniform Traffic Control Devices.
- Any changes that may adversely influence the crashworthiness of the device will require a new acceptance letter.
- Should the FHWA discover that the qualification testing was flawed, that in-service performance reveals unacceptable safety problems, or that the device being marketed is significantly different from the version that was crash tested, it reserves the right to modify or revoke its acceptance.
- You will be expected to supply potential users with sufficient information on design and installation requirements to ensure proper performance.
- You will be expected to certify to potential users that the hardware furnished has essentially the same chemistry, mechanical properties, and geometry as that submitted for acceptance, and that they will meet the crashworthiness requirements of FHWA and NCHRP Report 350.
- To prevent misunderstanding by others, this letter of acceptance, designated as number WZ-171 shall not be reproduced except in full. This letter, and the test documentation upon which this letter is based, is public information. All such letters and documentation may be reviewed at our office upon request.
- The Remcon barricades are patented devices and considered "proprietary." The use of proprietary work zone traffic control devices in Federal-aid projects is generally of a temporary nature. They are *selected by the contractor* for use as needed and removed upon completion of the project. Under such conditions they can be presumed to meet requirement "a" given below for the use of

proprietary products on Federal-aid projects. On the other hand, if proprietary devices are *specified by a highway agency* for use on Federal-aid projects they: (a) must be supplied through competitive bidding with equally suitable unpatented items; (b) the highway agency must certify that they are essential for synchronization with existing highway facilities or that no equally suitable alternative exists or; (c) they must be used for research or for a distinctive type of construction on relatively short sections of road for experimental purposes. These provisions do not apply to exempt Non-NHS projects. Our regulations concerning proprietary products are contained in Title 23, Code of Federal Regulations, Section 635.411, a copy of which is enclosed.

- This acceptance letter shall not be construed as authorization or consent by the FHWA to use, manufacture, or sell any patented device. Patent issues are to be resolved by the applicant and the patent owner.

Sincerely yours,

/Original Signed by/

John R. Baxter, P.E.
Director, Office of Safety Design
Office of Safety

Enclosures

FHWA:HSA-10:NArtimovich:tb:x61331:3/1/04

File: h://directory folder/nartimovich/WZ171-RemconFIN

cc: HSA-10 (Reader, HSA-1; Chron File, HSA-10;
N. Artimovich, HSA-10)

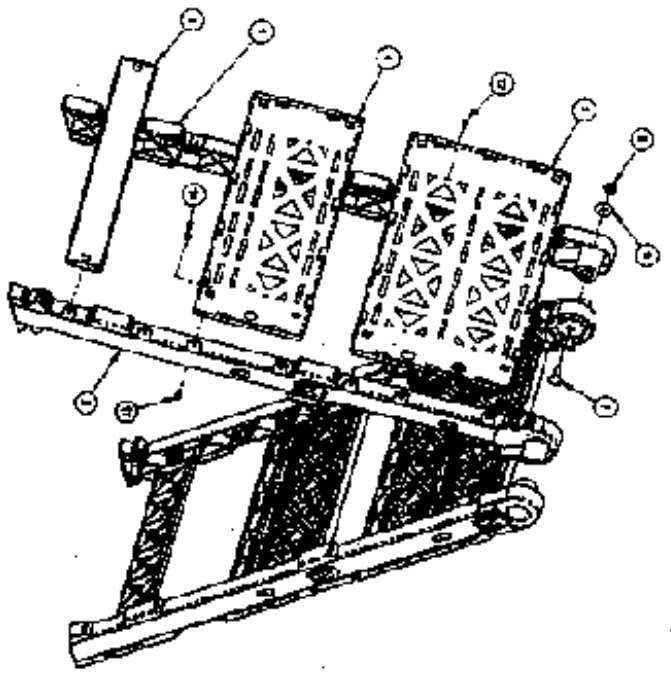

EXPLODED VIEW OF ROLLER ASSEMBLY

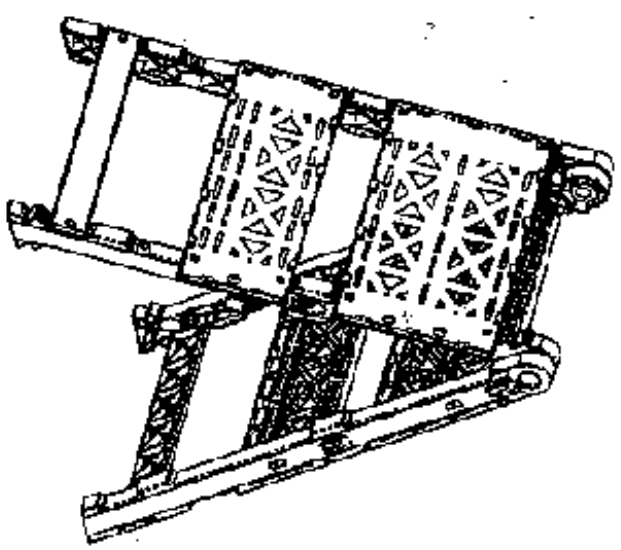

ASSEMBLED VIEW OF ROLLER ASSEMBLY

ITEM	QTY	DRAWING DESCRIPTION	NET WT. LBS	ASST. WT. LBS
1	1	ROLLER SET	2.08	4.31
2	2	NO. 2000 ROLLER	1.25	3.28
3	2	NO. 2000 ROLLER	1.25	3.28
4	2	NO. 2000 ROLLER	1.25	3.28
5	2	NO. 2000 ROLLER	1.25	3.28
6	2	NO. 2000 ROLLER	1.25	3.28
7	1	ROLLER SET - ALUMINUM FINISH	2.08	4.31
8	1	ROLLER SET - INVOCK FINISH	2.08	4.31
9	1	ROLLER SET - POLYURETHANE FINISH	2.08	4.31
10	20	ROLLERS WITH POLYURETHANE FINISH	0.20	0.40
11	20	ROLLERS WITH INVOCK FINISH	0.20	0.40
12	4	ROLLERS WITH ALUMINUM FINISH	0.50	0.20
13	2	ROLLER SET - ALUMINUM FINISH	2.08	4.31
14	2	ROLLER SET - INVOCK FINISH	2.08	4.31
15	2	ROLLER SET - POLYURETHANE FINISH	2.08	4.31
16	2	ROLLER SET - ALUMINUM FINISH	2.08	4.31
17	2	ROLLER SET - INVOCK FINISH	2.08	4.31
18	2	ROLLER SET - POLYURETHANE FINISH	2.08	4.31
19	2	ROLLER SET - ALUMINUM FINISH	2.08	4.31
20	2	ROLLER SET - INVOCK FINISH	2.08	4.31
21	2	ROLLER SET - POLYURETHANE FINISH	2.08	4.31
22	2	ROLLER SET - ALUMINUM FINISH	2.08	4.31
23	2	ROLLER SET - INVOCK FINISH	2.08	4.31
24	2	ROLLER SET - POLYURETHANE FINISH	2.08	4.31
25	2	ROLLER SET - ALUMINUM FINISH	2.08	4.31
26	2	ROLLER SET - INVOCK FINISH	2.08	4.31
27	2	ROLLER SET - POLYURETHANE FINISH	2.08	4.31
28	2	ROLLER SET - ALUMINUM FINISH	2.08	4.31
29	2	ROLLER SET - INVOCK FINISH	2.08	4.31
30	2	ROLLER SET - POLYURETHANE FINISH	2.08	4.31
31	2	ROLLER SET - ALUMINUM FINISH	2.08	4.31
32	2	ROLLER SET - INVOCK FINISH	2.08	4.31
33	2	ROLLER SET - POLYURETHANE FINISH	2.08	4.31
34	2	ROLLER SET - ALUMINUM FINISH	2.08	4.31
35	2	ROLLER SET - INVOCK FINISH	2.08	4.31
36	2	ROLLER SET - POLYURETHANE FINISH	2.08	4.31
37	2	ROLLER SET - ALUMINUM FINISH	2.08	4.31
38	2	ROLLER SET - INVOCK FINISH	2.08	4.31
39	2	ROLLER SET - POLYURETHANE FINISH	2.08	4.31
40	2	ROLLER SET - ALUMINUM FINISH	2.08	4.31
41	2	ROLLER SET - INVOCK FINISH	2.08	4.31
42	2	ROLLER SET - POLYURETHANE FINISH	2.08	4.31
43	2	ROLLER SET - ALUMINUM FINISH	2.08	4.31
44	2	ROLLER SET - INVOCK FINISH	2.08	4.31
45	2	ROLLER SET - POLYURETHANE FINISH	2.08	4.31
46	2	ROLLER SET - ALUMINUM FINISH	2.08	4.31
47	2	ROLLER SET - INVOCK FINISH	2.08	4.31
48	2	ROLLER SET - POLYURETHANE FINISH	2.08	4.31
49	2	ROLLER SET - ALUMINUM FINISH	2.08	4.31
50	2	ROLLER SET - INVOCK FINISH	2.08	4.31
51	2	ROLLER SET - POLYURETHANE FINISH	2.08	4.31
52	2	ROLLER SET - ALUMINUM FINISH	2.08	4.31
53	2	ROLLER SET - INVOCK FINISH	2.08	4.31
54	2	ROLLER SET - POLYURETHANE FINISH	2.08	4.31
55	2	ROLLER SET - ALUMINUM FINISH	2.08	4.31
56	2	ROLLER SET - INVOCK FINISH	2.08	4.31
57	2	ROLLER SET - POLYURETHANE FINISH	2.08	4.31
58	2	ROLLER SET - ALUMINUM FINISH	2.08	4.31
59	2	ROLLER SET - INVOCK FINISH	2.08	4.31
60	2	ROLLER SET - POLYURETHANE FINISH	2.08	4.31
61	2	ROLLER SET - ALUMINUM FINISH	2.08	4.31
62	2	ROLLER SET - INVOCK FINISH	2.08	4.31
63	2	ROLLER SET - POLYURETHANE FINISH	2.08	4.31
64	2	ROLLER SET - ALUMINUM FINISH	2.08	4.31
65	2	ROLLER SET - INVOCK FINISH	2.08	4.31
66	2	ROLLER SET - POLYURETHANE FINISH	2.08	4.31
67	2	ROLLER SET - ALUMINUM FINISH	2.08	4.31
68	2	ROLLER SET - INVOCK FINISH	2.08	4.31
69	2	ROLLER SET - POLYURETHANE FINISH	2.08	4.31
70	2	ROLLER SET - ALUMINUM FINISH	2.08	4.31
71	2	ROLLER SET - INVOCK FINISH	2.08	4.31
72	2	ROLLER SET - POLYURETHANE FINISH	2.08	4.31
73	2	ROLLER SET - ALUMINUM FINISH	2.08	4.31
74	2	ROLLER SET - INVOCK FINISH	2.08	4.31
75	2	ROLLER SET - POLYURETHANE FINISH	2.08	4.31
76	2	ROLLER SET - ALUMINUM FINISH	2.08	4.31
77	2	ROLLER SET - INVOCK FINISH	2.08	4.31
78	2	ROLLER SET - POLYURETHANE FINISH	2.08	4.31
79	2	ROLLER SET - ALUMINUM FINISH	2.08	4.31
80	2	ROLLER SET - INVOCK FINISH	2.08	4.31
81	2	ROLLER SET - POLYURETHANE FINISH	2.08	4.31
82	2	ROLLER SET - ALUMINUM FINISH	2.08	4.31
83	2	ROLLER SET - INVOCK FINISH	2.08	4.31
84	2	ROLLER SET - POLYURETHANE FINISH	2.08	4.31
85	2	ROLLER SET - ALUMINUM FINISH	2.08	4.31
86	2	ROLLER SET - INVOCK FINISH	2.08	4.31
87	2	ROLLER SET - POLYURETHANE FINISH	2.08	4.31
88	2	ROLLER SET - ALUMINUM FINISH	2.08	4.31
89	2	ROLLER SET - INVOCK FINISH	2.08	4.31
90	2	ROLLER SET - POLYURETHANE FINISH	2.08	4.31
91	2	ROLLER SET - ALUMINUM FINISH	2.08	4.31
92	2	ROLLER SET - INVOCK FINISH	2.08	4.31
93	2	ROLLER SET - POLYURETHANE FINISH	2.08	4.31
94	2	ROLLER SET - ALUMINUM FINISH	2.08	4.31
95	2	ROLLER SET - INVOCK FINISH	2.08	4.31
96	2	ROLLER SET - POLYURETHANE FINISH	2.08	4.31
97	2	ROLLER SET - ALUMINUM FINISH	2.08	4.31
98	2	ROLLER SET - INVOCK FINISH	2.08	4.31
99	2	ROLLER SET - POLYURETHANE FINISH	2.08	4.31
100	2	ROLLER SET - ALUMINUM FINISH	2.08	4.31

TOTAL ASSEMBLY WEIGHT LBS. 15.00

DRAWING NUMBER: RC-1014-C
 SHEET: 1 OF 1
 DATE: 10/15/54
 DESIGNED BY: [Name]
 CHECKED BY: [Name]
 APPROVED BY: [Name]
 TITLE: TYPE 1 BARRICADE
 MANUFACTURED BY: RENDON PLASTICS
 PART NUMBER: [Number]
 QUANTITY: [Quantity]

Sec. 635.411 Material or product selection.

(a) Federal funds shall not participate, directly or indirectly, in payment for any premium or royalty on any patented or proprietary material, specification, or process specifically set forth in the plans and specifications for a project, unless:

- (1) Such patented or proprietary item is purchased or obtained through competitive bidding with equally suitable unpatented items; or
- (2) The State highway agency certifies either that such patented or proprietary item is essential for synchronization with existing highway facilities, or that no equally suitable alternate exists; or
- (3) Such patented or proprietary item is used for research or for a distinctive type of construction on relatively short sections of road for experimental purposes.

(b) When there is available for purchase more than one nonpatented, nonproprietary material, semifinished or finished article or product that will fulfill the requirements for an item of work of a project and these available materials or products are judged to be of satisfactory quality and equally acceptable on the basis of engineering analysis and the anticipated prices for the related item(s) of work are estimated to be approximately the same, the PS&E for the project shall either contain or include by reference the specifications for each such material or product that is considered acceptable for incorporation in the work. If the State highway agency wishes to substitute some other acceptable material or product for the material or product designated by the successful bidder or bid as the lowest alternate, and such substitution results in an increase in costs, there will not be Federal-aid participation in any increase in costs.

(c) A State highway agency may require a specific material or product when there are other acceptable materials and products, when such specific choice is approved by the Division Administrator as being in the public interest. When the Division Administrator's approval is not obtained, the item will be nonparticipating unless bidding procedures are used that establish the unit price of each acceptable alternative. In this case Federal-aid participation will be based on the lowest price so established.

(d) Appendix A sets forth the FHWA requirements regarding (1) the specification of alternative types of culvert pipes, and (2) the number and types of such alternatives which must be set forth in the specifications for various types of drainage installations.

(e) Reference in specifications and on plans to single trade name materials will not be approved on Federal-aid contracts.