



U.S. Department
of Transportation

**Federal Highway
Administration**

June 3, 1999

400 Seventh St., S.W.
Washington, D.C. 20590

Refer to: HMHS

Mr. Jan Miller
Eastern Metal/USA Sign
1430 Sullivan Street
Elmira, NY 14901-1698

Dear Mr. Miller:

Thank you for your letters of January 20 and May 3 requesting Federal Highway Administration (FHWA) acceptance of a number of your company's barricades and portable sign stands as crashworthy traffic control devices for use in work zones on the National Highway System (NHS). Accompanying your January 20 letter was a copy of the crash test report by Safety Quest, Inc., and a video documentation of the crash tests. You requested that we find the tested devices, as well as certain lighter or smaller devices of similar design, acceptable for use on the NHS. Through subsequent correspondence and conversations with Mr. Nicholas Artimovich of my office you provided additional information.

The FHWA guidance on crash testing of work zone traffic control devices is contained in two memoranda. The first, dated July 25, 1997, titled "Information: Identifying Acceptable Highway Safety Features," established four categories of work zone devices: Category I devices were those lightweight which could be self-certified by the vendor, Category II devices were other lightweight devices which needed individual crash testing, Category III devices were barriers and other fixed or massive devices also needing crash testing, and Category IV devices were trailer mounted lighted signs, arrow panels, etc. The second guidance memorandum was issued on August 28, 1998, and is titled "INFORMATION: Crash Tested Work Zone Traffic Control Devices." This recent memorandum lists devices that are acceptable under Categories I, II, and III. The devices tested for your company are all "Category II" devices.

You have requested acceptance for the devices listed below. The enclosed tables and product literature provide additional significant details.

"Melba Vertical Panel" is an all plastic channelizer constructed from recycled PVC. Panels are attached to a recycled PVC composite base by inserting two thin walled polyethylene pipes into holes located in the base structure and up into hollow cavities in the panel. Self-tapping screws hold the panel in place. The tested device used a 1067-mm tall, 305-mm wide panel.

“Melba Type I Long Board 2 Base Barricade with Sign Panel Attached” uses similar base and panel components as the vertical panel. Additional hardware includes PVC composite collar recepticals (connecting hardware) and polyethylene tubes (support posts.) A polycarbonate sign was mounted on the test article and is an optional device. The barricade panel was 1829-mm long and 229-mm wide.

“Melba Type II Highway 2-Base Barricade” is a two-rail version of the barricade described above but using shorter panels, reducing the overall width. Additional PVC composite connectors are used to mount the rails in place. The barricade panels were 610-mm long and 305-mm wide.

“C-202 Series Wind Deflecting Super-Flex Compact Stand” is a portable sign stand with a vertical fiberglass leaf spring to support roll-up signs. The base of the stand is 16-ga cold-formed ASTM A-500 steel tubing. A 6 x 457 x 51- mm fiberglass leaf spring is used to attach the base unit to the fiberglass vertical brace for the sign. A screw clamp holds the upper steel tube to the fiberglass leaf spring. The upper steel tube is a “mini mast” which accepts the roll up sign’s vertical brace. The sign’s horizontal brace is also fiberglass. A steel holder for flags is riveted to the top of the vertical sign brace

“C-902 Series Wind Deflecting Super-Flex Compact Stand” for roll-up signs differs from the C-202 in that the base legs are 6061-T6 aluminum rather than steel.

“X-600 Series Wind Deflecting Interstate Series Sign Stand” uses two vertically mounted steel coil springs above a base of 6061-T6 aluminum legs. The vertical mast is similar aluminum square tubing. This support was tested with both roll-up and rigid aluminum signs. Sign stands supporting aluminum substrate sign panels are not included in this acceptance, pending additional testing with the signs oriented 90 degrees to the impacting vehicle.

“X-500 Series Spring Mounted Sign Stand” is similar to the X-600 series except for the reduced height. Our review of the X-600 tests indicates that the smaller X-500 stands supporting roll-up signs would perform in a similar manner.

Crash Test Summary

Full-scale automobile testing was conducted on your company’s barricades and portable sign supports. In all tests two devices were tested in tandem, one head-on and the next at 90 degrees. In some cases the same device was tested in both orientations as called for in our guidance memoranda. In others, different devices of the same “family” were tested to evaluate a wider range of hardware. “Enclosure A” is a summary of the tested devices. Enclosure “B” is illustrations of the tested device, and Appendix “C” is the summary of the crash tests conducted.

During most of the tests the most extensive windshield damage (for the specific devices you are requesting acceptance for) was minor cracking. Tests of the Melba vertical panel and Type II barricade with lights were an exception. The lights separated from the devices and caused significant local cracking. The pattern of cracking was not bad enough to obscure driver visibility, but the glass was dished in to the point where it contacted the protective screen that was shielding the live driver. It is unknown how much more severe the damage would have been without the protective screen in place.

The FHWA considered your request to find portable sign stands using aluminum sign panels acceptable for use without the end-on testing called for in our July 25, 1997, memorandum. You stated that your "Interstate" model sign support is intended only for use on high-speed freeways, and that it would be possible to prohibit the installation of the stands with the signs oriented end-on through training and the use of labels on the supports themselves. It is our belief that the common industry practice of turning the signs to face away from approaching traffic would be exceptionally difficult to stop. Also the effects of a vehicle striking the side of a support holding an aluminum blank are unknown. Therefore, additional testing will be required before portable sign stands with any rigid sign substrate will be considered for use.

For the successful tests of your devices there was no occupant compartment intrusion or deformation observed, nor did any test article debris show potential for penetrating the occupant compartment. The results of this testing met the NCHRP Report 350 and FHWA requirements. Therefore, the devices listed below and described above and in Enclosures A and B are acceptable for use on the National Highway System with "roll-up" signs under the range of conditions tested, without lights, when proposed by a state:

- Melba Vertical Panel
- Melba Type II Barricade
- Melba Type I Long Board Barricade with Sign
- Super Flex Compact Stand with Fiberglass Leaf Spring C-200, C-202, C-242, C-232 (galvanized steel construction)
- Super Flex Compact Stand with Fiberglass Leaf Spring C-902, C-942, C-942 (Aluminum construction)
- Interstate Stands, with Full Size Coil Spring X-600 Series (Alum), Model X-601 X-500 Series (Alum.), Model X-501, X-550 (Galv. steel), Model X-551
-

The testing of the above stands also permits us to find the following stands acceptable with "roll-up" signs (some of these stands were already covered by our Acceptance Letter WZ-7).

Descriptive information may be found in enclosure B.

- Hi-Performance Compact Stands C-102, C-132, C-142 (Steel)
- C-802, C-842, C-832 Sign Stands (Aluminum)

Our acceptance is limited to the crashworthiness characteristics of the devices and does not cover their structural features, nor conformity with the Manual on Uniform Traffic Control Devices. Presumably, you will supply potential users with sufficient information on design and installation requirements to ensure proper performance. We anticipate that the States will require certification from Eastern Metal/USA-SIGN that the hardware furnished has essentially the same chemistry, mechanical properties, and geometry as that submitted for acceptance. To prevent misunderstanding by others, this letter of acceptance, designated as number WZ-13, shall not be reproduced except in full.

The Eastern Metal/USA-SIGN and/or MELBA hardware are patented products and considered "proprietary." The use of proprietary work zone traffic control devices in Federal-aid projects is generally of a temporary nature. They are selected by the contractor for use as needed and removed upon completion of the project. Under such conditions they can be presumed to meet requirement "a" given below for the use of proprietary products on Federal-aid projects. On the other hand, if proprietary devices are specified for use on Federal-aid projects, except exempt, non-NHS projects, they: (a) must be supplied through competitive bidding with equally suitable unpatented items; (b) the highway agency must certify that they are essential for synchronization with existing highway facilities or that no equally suitable alternative exists or; (c) they must be used for research or for a distinctive type of construction on relatively short sections of road for experimental purposes. Our regulations concerning proprietary products are contained in Title 23, Code of Federal Regulations, Section 635.411, a copy of which is enclosed.

Sincerely yours,



Dwight A. Horne
Director, Office of Highway Safety
Infrastructure

3 Enclosures

FHWA:HMHS:NArtimovich:x61331:5/28/99

cc: Reader - HMHS, Chron - Rm 3407

N. Artimovich - HMHS

FHWA Field Offices w/enclosures

Product Specification Sheet



4212-EG Vertical Channelizer

Description:

Eastern Metal/USA-SIGN Melba '98 Large Vertical Panel Channelizer.
(Barricade Light not included)

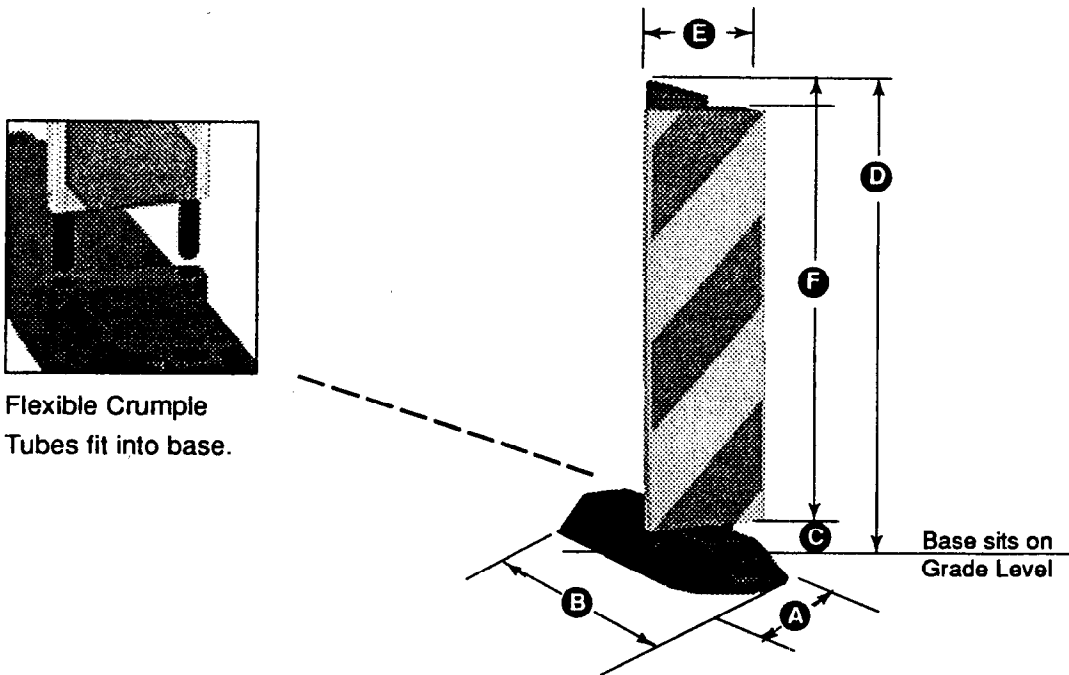

Model Number	Channelizer Description	Weight	Foot Print		Above Grade	Bottom Top of	Width of Panel	Height of Panel
			Width A	Depth B	of Panel C	Panel D		
V-4212-EG*	12" Vertical Panel - 42" High	30.1 lbs	12"	24"	3"	45"	12"	42"
V-3612-EG	12" Vertical Panel - 36" High	28.0 lbs	12"	24"	3"	39"	12"	36"
V-429-EG	9" Vertical Panel - 42" High	27.9 lbs	12"	24"	3"	45"	9"	42"
V-369-EG	9" Vertical Panel - 36" High	27.2 lbs	12"	24"	3"	39"	9"	36"

Common Material/Construction Features

Barricade Panels: 1-1/4" thick reinforced hollow 100% Recycled UV Stable Window Grade PVC.

Attachment, Flexible Crumple Tube: 18" x 1" dia. x 1/8" wall thickness, Recycled Polyethylene

Base and Handle: 100% Recycled High Compression, High Density PVC Composite. (Base weight 23 lbs)

Attachment Method: Handle & Crumple Tubes to panel with self-tapping Galvanized Screws.

Figure 2. Product specification sheet (Large Panel Vertical Channelizer)

*Tested Product

12/2/98

Product Specification Sheet



B2-2-12924-EG Type II Barricade

Description:

Eastern Metal/USA-SIGN Melba '98 Type II Highway 2-Base Barricade/Directional Barricade.
(Barricade Light not included)

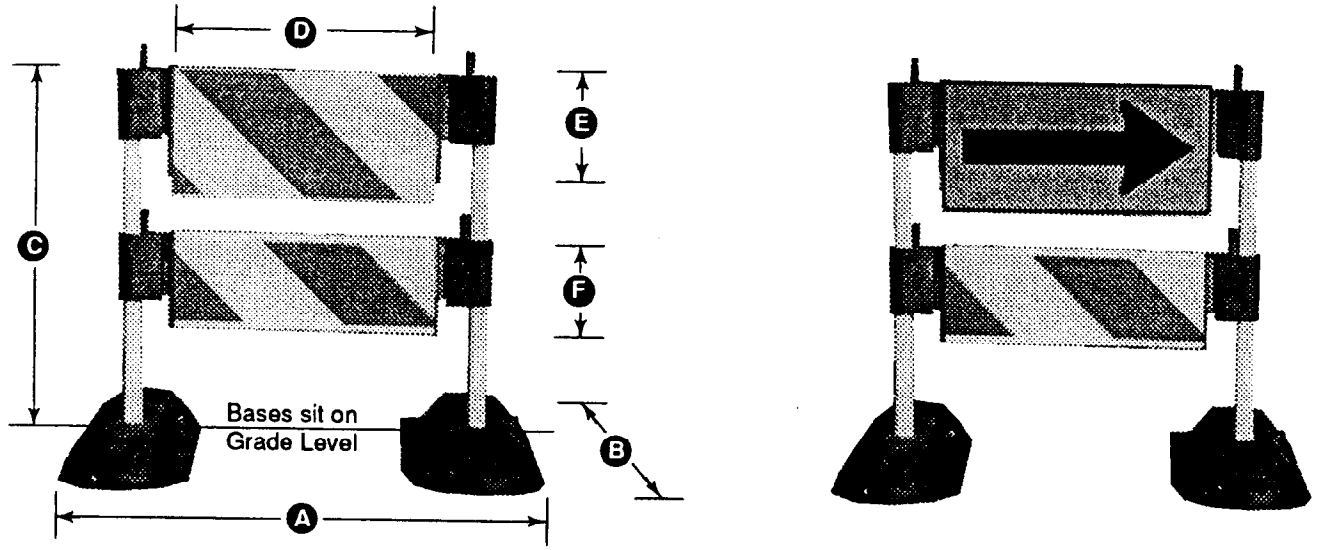

Model Number	Description	Weight	Foot Print		Top of Panel C	Width of Panel D	Height of Panel E	Height of Panel F
			A	B				
B2-2-12924-EG*	Type II Barricade- 2 Panels	62.7 lbs	43"	24"	37"	24"	12"	9"
B2-2-9924-EG	Type II Barricade- 2 Panels	61.7 lbs	43"	24"	37"	24"	9"	9"
B2-1-924-EG	Type I Barricade- 1 Panel	57.7 lbs	43"	24"	37"	24"	9"	

Common Material/Construction Features

Barricade Panels: 1-1/4" thick reinforced hollow 100% Recycled UV Stable Window Grade PVC.

Vertical Support Tubing: 36" high x 42mm dia. x 3.5mm wall thickness, 100% Recycled Polyethylene with Recycled PVC Insert Stiffener Tube.

Bases, Collars, and Panel End-caps: 100% Recycled High Compression, High Density PVC Composite.

(Base weight 23 lbs)

Attachment Method: Collars and panel end-caps with self-tapping Galvanized Screws.

Figure 6. Product specification sheet (Type II Highway 2-Base Barricade/Directional Barricade)

*Tested Product

Product Specification Sheet



B2-1-972-EG Type I Barricade

Description:

Eastern Metal/USA-SIGN Melba '98 Type I "long board" 2-Base Barricade with 48" wide x 24" high sign panel attached.

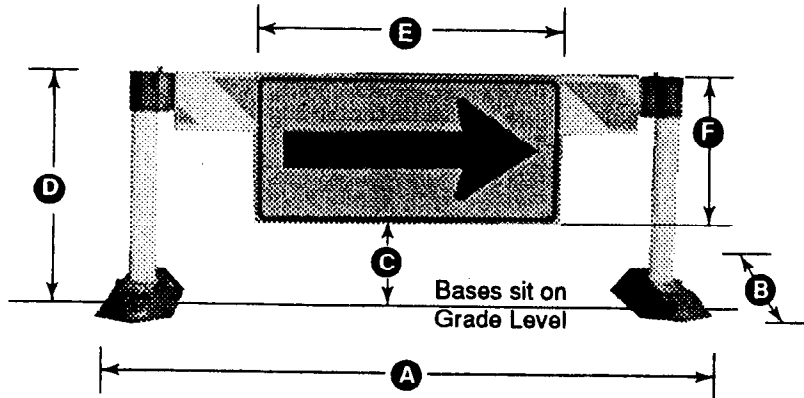

Model Number	Description	Weight	Foot Print		Above Grade		Width of Sign (E)	Height of Sign (F)
			Width (A)	Depth (B)	Bottom of Sign (C)	Top of Blade (D)		
B2-1-972-EG-001*	Type I Barricade & Sign	70.2 lbs	94"	24"	13"	37"	48"	24"
B2-1-972-EG	Type I Barricade - 6'	65.8 lbs	94"	24"		37"		
B2-1-960-EG	Type I Barricade - 5'	64.4 lbs	82"	24"		37"		
B2-1-948-EG	Type I Barricade- 4'	63.1 lbs	70"	24"		37"		
B2-1-936-EG	Type I Barricade- 3'	61.8	58"	24"		37"		

Common Material/Construction Features

Barricade Panels: 1-1/4" thick reinforced hollow 100% Recycled UV Stable Window Grade PVC.

Vertical Support Tubing: 36" High x 96mm dia. x 2.5mm Wall thickness, 100% Recycled Polyethylene.

Base and Handle: 100% Recycled High Compression, High Density PVC Composite. (Base weight 23 lbs)

Attachment Method: Self-Tapping Galvanized Screws.

Sign Panel: 48" wide x 24" high x .080" thick Polycarbonate Panel with reflective sheeting.

Figure 4. Product specification sheet (Type I "long board" 2-Base Barricade with Sign)

Product Specification Sheet



C-202/200 Series Sign Stand

Description:

Eastern Metal/USA-SIGN C/48 Series C-Sign, 48" Diamond Roll-up Sign with 3 wood dowel flags, attached to C-202/200 Series Wind Deflecting Super-Flex™ Compact Sign Stand.

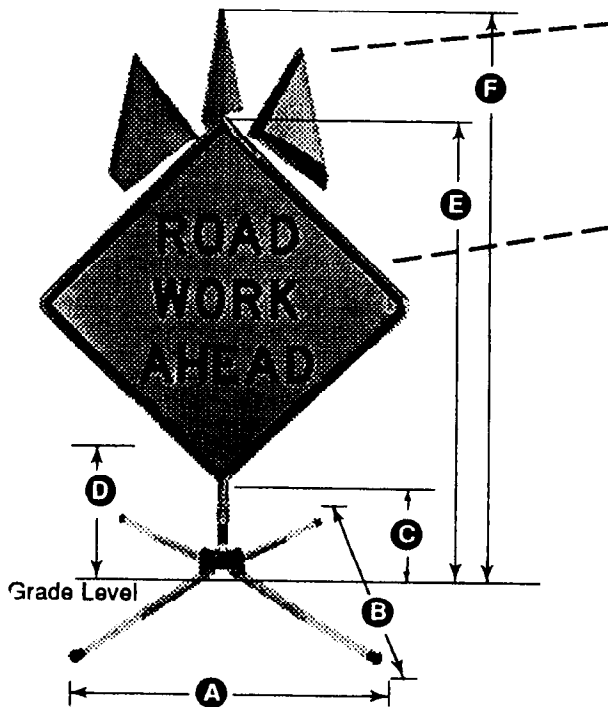

FROV-118/24* 18" Square fluorescent vinyl flags on 24" x 3/4" wooden staffs.
Individual Flag Weight: 0.4 lbs

Roll-up Sign Material/Construction Features:
Roll-up "C" Signs: All Fabrics, w/ 3/16" or 5/16" thick Horizontal and 3/8" thick Vertical Fiberglass Cross Braces, lexan pockets and washers with steel or molded plastic flag holder attached to top of vertical cross brace inside sign perimeter. With exception of hardware, no other metal parts are used.

C/48-* 48" Roll-up Sign for Compact Stands .
(16 square feet of Roll-up Material)
Total Sign Weight:..... 6.6 lbs

C/36- 36" Roll-up Sign for Compact Stands
(9 square feet of Roll-up Material)
Total Sign Weight:..... 4.2 lbs

Model Number	Description	Weight	Fully Extended Foot Print		Height Above Grade Level			
			Width (A)	Depth (B)	Bottom of Sign (C)	Top of Mast (D)	Top of Sign (E)	Top of Flag (F)
C-202*	Series Standard Steel Super-Flex Compact Stand	24.0 lbs	42-1/2"	69"	18"	26-1/2"	85"	98-1/2"
C-200	(Same) with Different Pull-release leg set-up method	28.0 lbs	46"	72-1/2"	18"	27-1/2"	85"	98-1/2"
C-242	(Same) with foot-release leg set-up method	22 lbs	42"	68"	18"	26-1/2"	85"	98-1/2"

Stand Material/Construction Features:

Stand Tubing: 16 ga. Cold-formed galvanized 1-1/4", and 1" tubing ASTM-A500 Rated Steel.

Wind-deflecting Leaf-Spring™: 1/4" thick x 18" h x 2" w, custom formulated pultruded fiberglass sandwiched by protective plastic spacers with predictable shear point at approximately 6" above grade.

Common 1-1/4" Steel tubing mini-mast attaches to leaf-spring with adjustable turn-knob pressure plate for movement up from lowest setting to create more flex. Test performed at mid-range setting. Same tightening turn-knob pressure plate concept used at mast top, to attach sign to stand at predetermined minimum height setting.

Figure 8. Product specification sheet (C-202 Series Wind Deflecting Super-Flex™ Compact Stand™)

*Tested Product

12/2/98

Product Specification Sheet



C-902 Series Sign Stand

Description:

Eastern Metal/USA-SIGN C/48 Series C-Sign, 48" Diamond Roll-up Sign with 3 wood dowel flags, attached to C-902 Series Wind Deflecting Super-Flex™ Compact Sign Stand.

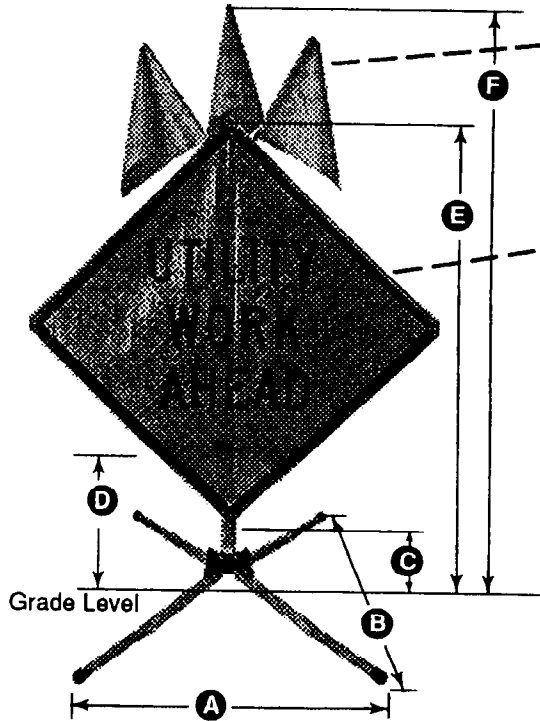

FROV-118/24* 18" Square fluorescent vinyl flags on 24" x 3/4" wooden staffs.
Individual Flag Weight: 0.4 lbs

Roll-up Sign Material/Construction Features:
Roll-up "C" Signs: All Fabrics, w/ 3/16" or 5/16" thick Horizontal and 3/8" thick Vertical Fiberglass Cross Braces, lexan pockets and washers with steel or molded plastic flag holder attached to top of vertical cross brace inside sign perimeter. With exception of hardware, no other metal parts are used.

C/48-* 48" Roll-up Sign for Compact Stands .
(16 square feet of Roll-up Material)
Total Sign Weight:..... 5.3 lbs

C/36- 36" Roll-up Sign for Compact Stands
(9 square feet of Roll-up Material)
Total Sign Weight:..... 3.3 lbs

Model Number	Description	Weight	Fully Extended Foot Print		Above Grade Level		Top of Sign	Top of Flag
			Width A	Depth B	Bottom of Sign C	Top of Mast D		
C-902*	Series Standard Super-flex Compact Stand	20.0 lbs	42-1/2"	69"	18"	26-1/2"	85"	98-1/2"
C-942	(Same as above) with foot-release leg set-up method	18.0 lbs	42"	68"	18"	26-1/2"	85"	98-1/2"

Stand Material/Construction Features:

Stand Tubing: 16 ga. Cold-formed galvanized 1-1/4", and 1" tubing ASTM-A500 Rated Steel.

Wind-deflecting Leaf-Spring™: 1/4" thick x 18" h x 2" w, custom formulated pultruded fiberglass sandwiched by protective plastic spacers with predictable shear point at approximately 6" above grade.

Common 1-1/4" Steel tubing mini-mast attaches to leaf-spring with adjustable turn-knob pressure plate for movement up from lowest setting to create more flex. Test performed at mid-range setting. Same tightening turn-knob pressure plate concept used at mast top, to attach sign to stand at predetermined minimum height setting.

Figure 10. Product specification sheet (C-902 Series Wind Deflecting Super-Flex™ Compact Stand™)

Product Specification Sheet



600/X-500 Series Sign Stands

Description:

Eastern Metal/USA-SIGN 48" Diamond Roll-up Sign or a Rigid Aluminum Sign with 3 wood dowel flags, attached to **X-600** Series Wind Deflecting Interstate Series Sign Stand.

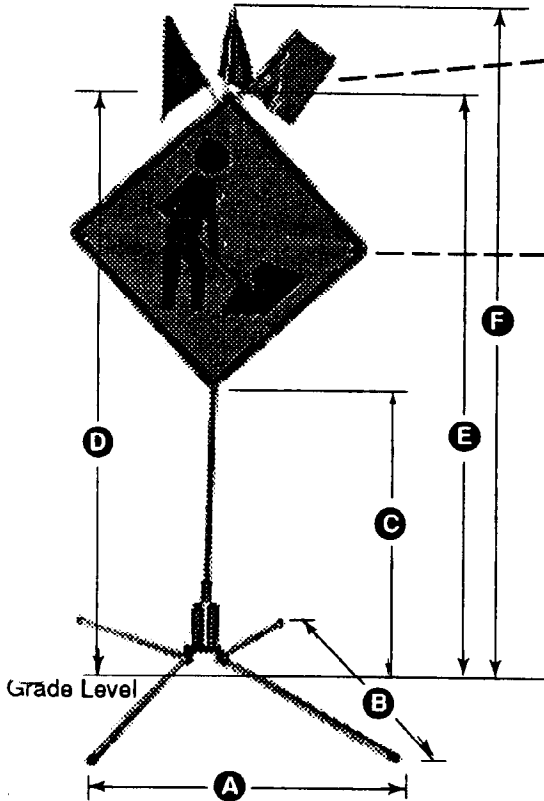

FROV-118/24* 18" Square fluorescent vinyl flags on 24" x 3/4" wooden staffs.
Individual Flag Weight: 0.4lbs

Roll-up Sign Material/Construction Features:

Roll-up Signs: All Fabrics, with 3/16" thick Horizontal and Vertical Fiberglass Cross Braces, lexan pockets and washers. With exception of hardware, no other metal parts are used.

- 48-RR* 48" Roll-up Sign
(16 square feet of Roll-up Material)
Total Sign Weight: 5.3 lbs
- 36-RR 36" Roll-up Sign
(9 square feet of Roll-up Material)
Total Sign Weight: 3.3 lbs

Rigid Sign Material/Construction Features:

- Rigid Sign: 48" Diamond Shaped .080" Aluminum with reflective sheeting (16 square feet)
Total Sign Weight: 18.2 lbs
- Rigid Sign: 36" Diamond Shaped .080" Aluminum with reflective sheeting (9 square feet)
Total Sign Weight: 10.2 lbs

Model Number	Description	Fully Extended Weight	Foot Print		Height Above Grade Level			
			Width (A)	Depth (B)	Bottom of Sign (C)	Top of Mast (D)	Top of Sign (E)	Top of Flag (F)
X-600*	Large Interstate Dual Coil Spring Aluminum Sign Stand with steel Roll-up Sign bracket on mast	52 lbs	52"	121.5"	60"	136"	136"	156"
X-500	Mid Size Interstate Dual Coil Spring Aluminum Sign Stand with steel Roll-up Sign bracket on mast	34.0 lbs	36"	81"	12"	96"	96"	116"

Stand Material/Construction Features:

Stand Tubing: .125" Wall thickness x 1-19/16" and 1-1/4" 6061-T6 Extruded Aluminum

Spring System: 2 Vertical heavy coil steel springs mounted to base and mast with bolt/lock washer set threading into custom composite cast "plug" turned into spring.

Sign Bracket(s), Flag Holder, Connecting Brackets: Formed/Fabricated Steel with powder coated finish.

Figure 12. Product specification sheet (X-600 Series Wind Deflecting Interstate™ Series Sign Stand)

*Tested Product

Product Specification Sheet



X-550 Series Sign Stands

Description:

Eastern Metal/USA-SIGN 48" Diamond Roll-up Sign with 3 wood dowel flags, attached to X-550 Series Wind Deflecting Interstate Series Sign Stand.

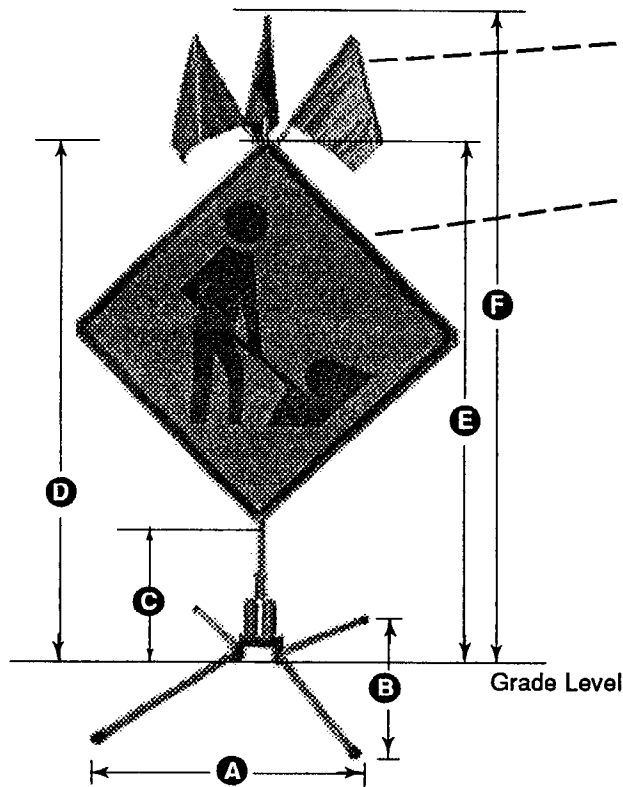

FROV-118/24 18" Square fluorescent vinyl flags on 24" x 3/4" wooden staffs.
Individual Flag Weight: 0.4lbs

Roll-up Sign Material/Construction Features:
Roll-up Signs: All Fabrics, with 3/16" thick Horizontal and Vertical Fiberglass Cross Braces, lexan pockets and washers. With exception of hardware, no other metal parts are used.

48-RR 48" Roll-up Sign
(16 square feet of Roll-up Material)
Total Sign Weight: 5.3 lbs

36-RR 36" Roll-up Sign
(9 square feet of Roll-up Material)
Total Sign Weight: 3.3 lbs

Model Number	Description	Fully Extended Weight	Height Above Grade Level					
			Foot Print Width A	Foot Print Depth B	Bottom of Sign C	Top of Mast D	Top of Sign E	Top of Flag F
X-550	Mid Size Interstate Dual Coil Spring Steel Sign Stand with steel Roll-up Sign bracket on mast	35.0 lbs	36"	80"	18"	96"	96"	116"

Stand Material/Construction Features:

Stand Tubing: 16 ga. Cold-formed galvanized 1-1/4", and 1" tubing ASTM-A500 Rated Steel.

Spring System: 2 Vertical heavy coil steel springs mounted to base and mast with bolt/lock washer set threading into custom composite cast "plug" turned into spring.

Base, Sign Bracket(s), Flag Holder, Connecting Brackets: Formed/Fabricated Steel with powder coated finish.

Product Specification Sheet



102/142 Series Sign Stand

Description:

Eastern Metal/USA-SIGN C/48 Series C-Sign, 48" Diamond Roll-up Sign with 3 wood dowel flags, attached to C-102/142 Series Wind Deflecting Super-Flex™ Compact Sign Stand.

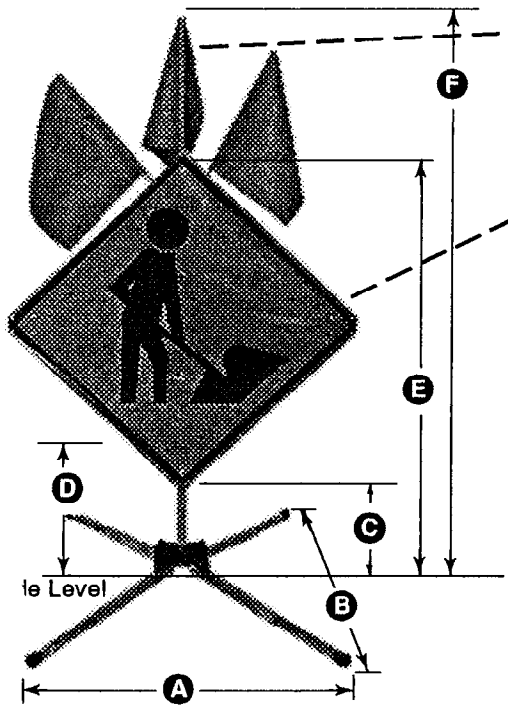

FROV-118/24* 18" Square fluorescent vinyl flags on 24" x 3/4" wooden staffs.
Individual Flag Weight: 0.4 lbs

Roll-up Sign Material/Construction Features:
Roll-up "C" Signs: All Fabrics, w/ 3/16" or 5/16" thick Horizontal and 3/8" thick Vertical Fiberglass Cross Braces, lexan pockets and washers with steel or molded plastic flag holder attached to top of vertical cross brace inside sign perimeter. With exception of hardware, no other metal parts are used.

C/48-* 48" Roll-up Sign for Compact Stands .
(16 square feet of Roll-up Material)
Total Sign Weight:..... 6.6 lbs

C/36- 36" Roll-up Sign for Compact Stands
(9 square feet of Roll-up Material)
Total Sign Weight:..... 4.2 lbs

Model Number	Description	Weight	Fully Extended Foot Print		Height Above Grade Level			
			Width A	Depth B	Bottom of Sign C	Top of Mast D	Top of Sign E	Top of Flag F
C-102	Series Standard Steel Super-Flex Compact Stand	22.0 lbs	41"	70"	15"	27-3/4"	82"	95-1/2"
C-142	(Same) with foot-release leg set-up method	20.0 lbs	40-1/2"	69"	15"	27-3/4"	82"	95-1/2"

Stand Material/Construction Features:

Stand Tubing: 16 ga. Cold-formed galvanized 1-1/4", and 1" tubing ASTM-A500 Rated Steel.

Wind-deflection: Non-deflecting mast, wind-deflection achieved from roll-up sign.

Product Specification Sheet

C-802/842 Series Sign Stand

Description:

Eastern Metal/USA-SIGN C/48 Series C-Sign, 48" Diamond Roll-up Sign with 3 wood dowel flags, attached to C-802/842 Series Wind Deflecting Super-Flex™ Compact Sign Stand.

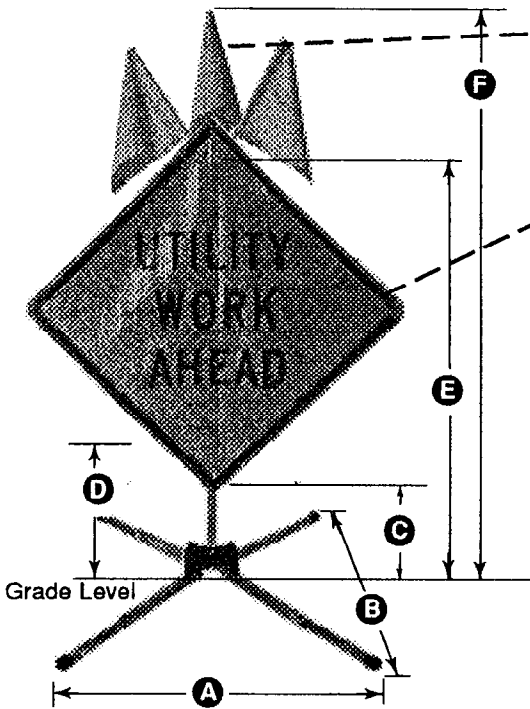

FROV-118/24* 18" Square fluorescent vinyl flags on 24" x 3/4" wooden staffs.
Individual Flag Weight: 0.4 lbs

Roll-up Sign Material/Construction Features:
Roll-up "C" Signs: All Fabrics, w/ 3/16" or 5/16" thick Horizontal and 3/8" thick Vertical Fiberglass Cross Braces, lexan pockets and washers with steel or molded plastic flag holder attached to top of vertical cross brace inside sign perimeter. With exception of hardware, no other metal parts are used.

C/48-* 48" Roll-up Sign for Compact Stands .
(16 square feet of Roll-up Material)
Total Sign Weight:..... 6.6 lbs

C/36- 36" Roll-up Sign for Compact Stands
(9 square feet of Roll-up Material)
Total Sign Weight:..... 4.2 lbs

Model Number	Description	Weight	Fully Extended Foot Print		Height Above Grade Level			
			Width A	Depth B	Bottom of Sign C	Top of Mast D	Top of Sign E	Top of Flag F
C-802	Series Standard Steel Super-Flex Compact Stand	18.0 lbs	41"	70"	15"	27-3/4"	82"	95-1/2"
C-842	(Same) with foot-release leg set-up method	16.0 lbs	40-1/2"	69"	15"	27-3/4"	82"	95-1/2"

Stand Material/Construction Features:

Stand Tubing: .125" Wall thickness x 1-19/16" and 1-1/4" 6061-T6 Extruded Aluminum

Wind-deflection: Non-deflecting mast, wind-deflection achieved from roll-up sign.

Common 1-1/4" Steel tubing mini-mast.