



Algal Laboratory Methodology

Where are we going

And

how do we not screw it up?

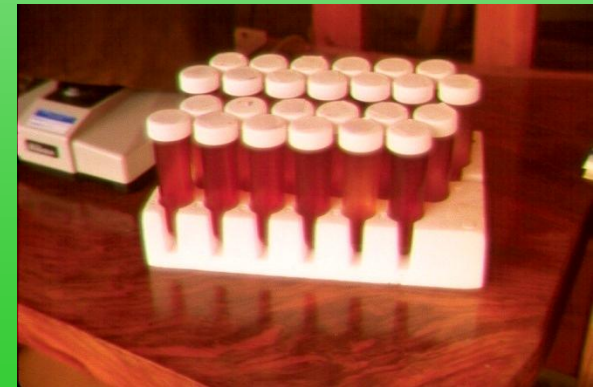

Algal Laboratory Methodology

Sampling and
Analysis should
be based on
project Goals,
NOT goals based
Sampling and
Analysis



Algal Laboratory Methodology

For Example:

**RBP is a stream
sampling and
analysis protocol,
NOT a plankton
protocol**



Algal Laboratory Methodology

Preservation – **NO** perfect preservative

- **Formaldehyde** - hazardous fumes, distorts many cells, bleaches color, added at 2-5% as formalin (40% formaldehyde)
- **Lugol's Iodine** - stains starch, may cause loss of flagella, loses preservative power over time-must re-add every 6 months, added at 1-2%, can cause 30-40% shrinkage from live biovolume
- **Glutaraldehyde** - hazardous fumes, retains color and fluorescence, limited cell distortion, added at only 0.25-1%

Algal Laboratory Methodology

Concentration Methods

- Concentrate to get a higher density for counting
- Don't have to count in the same chamber you concentrate in, so you can build your own settling tower or buy an utermohl

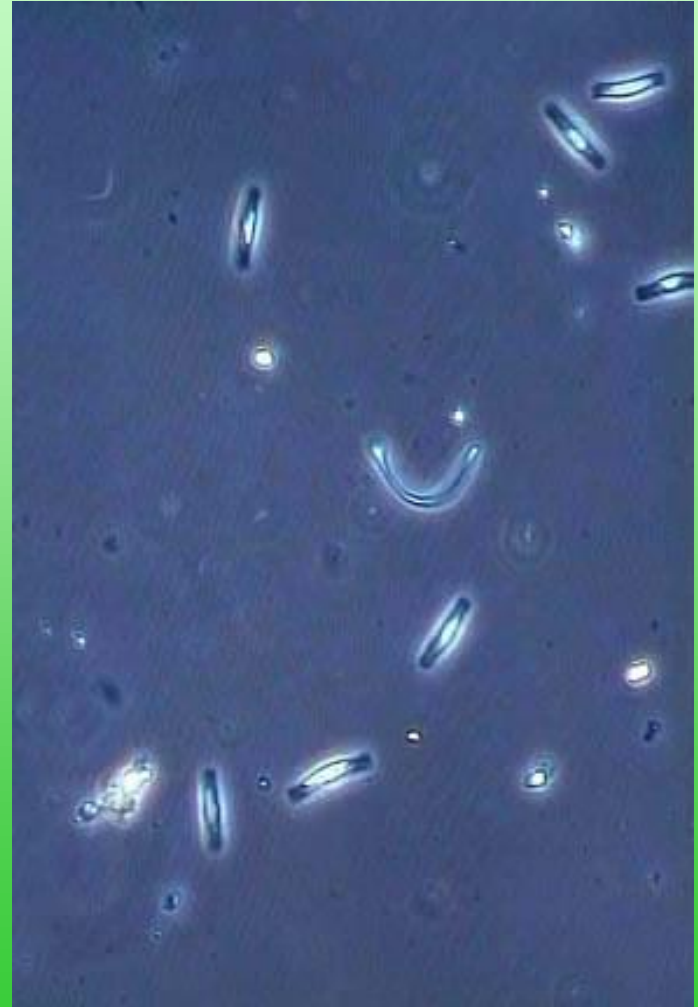

Algal Laboratory Methodology

More Concentration Methods

- Centrifugation (not recommended for counting, disrupts flagellates, hard to make it quantitative)
- Filtration & Reverse Filtration-not often used

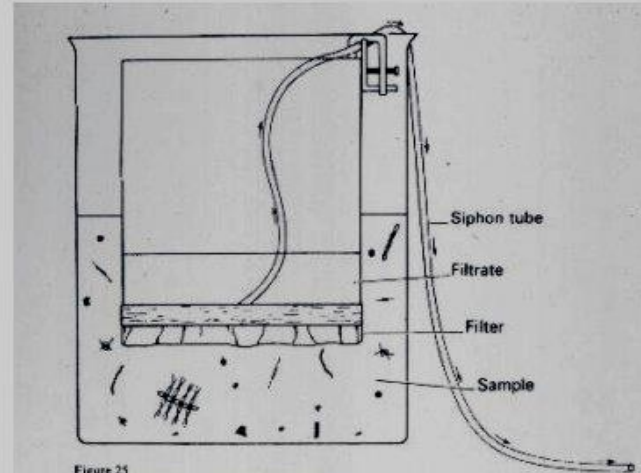
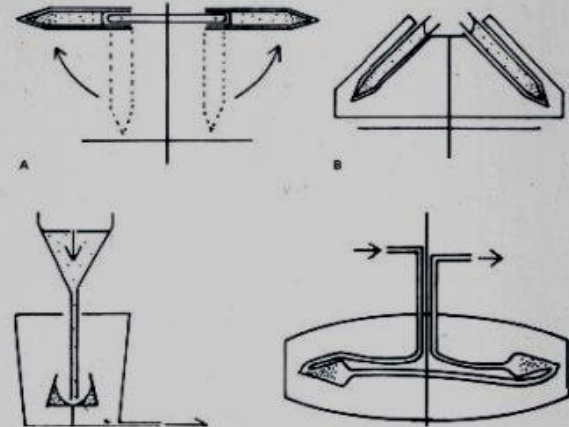

Figure 25
Schematic drawing of a reverse-filtration device.



Algal Laboratory Methodology

Temporary Mounting Methods*

- Less investment of materials/equipment
- Can be faster if sample already concentrated
- No mounting distortion
- Settle 1 cm/hr, can take days to settle a sample
- Buoyant blue-green algae/nannoplankton don't settle well
- Limited to certain microscope choices because generally a thick preparation

***I use a permanent mounting method, see me if you are interested**

Algal Laboratory Methodology

Which Counting Chamber?

- Density of sample
- Particulates/color
- Size distribution of algae
- Type of microscope
- Cost

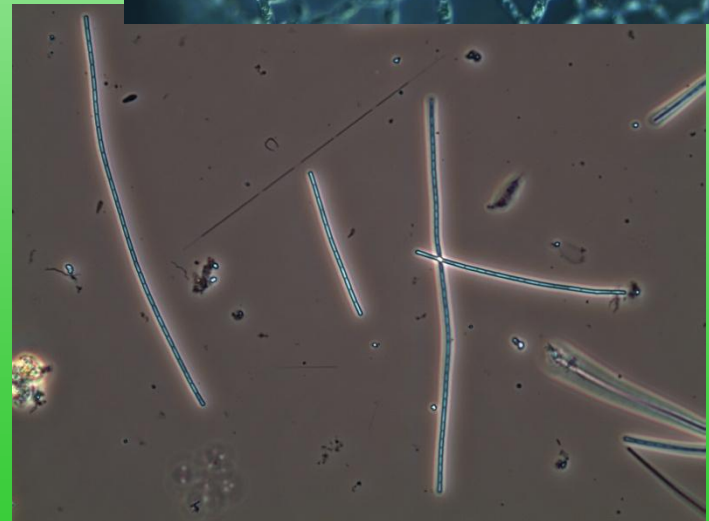
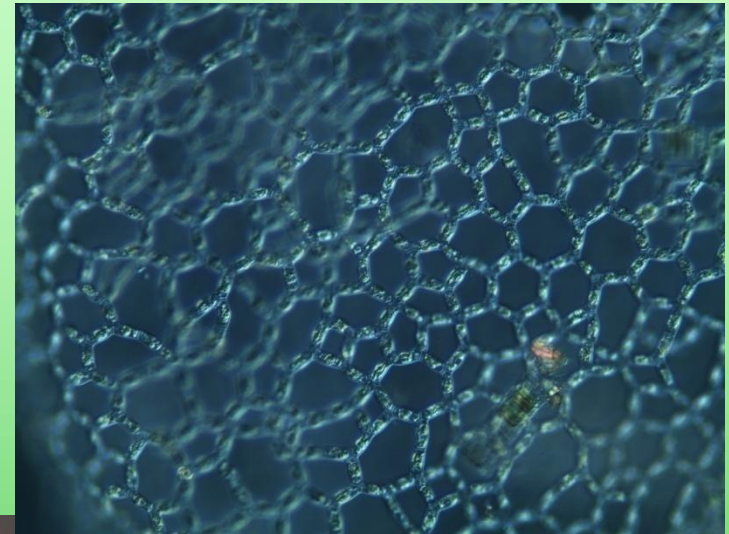

Algal Laboratory Methodology

Temporary Chambers

- Sedgwick-Rafter Cells (grid or non-grid)
- Nanoplankton Counting Chambers
- Palmer-Maloney Cells



Remember: Concentrated Sample!

Algal Laboratory Methodology

Temporary Chambers

Utermohl Chambers-just a note!

- ❖ Buoyant blue-greens present a problem and don't settle randomly or don't settle at all.
- ❖ Percussive techniques help them settle, you literally hit your chamber with a rubber mallet (VERY CAREFULLY).

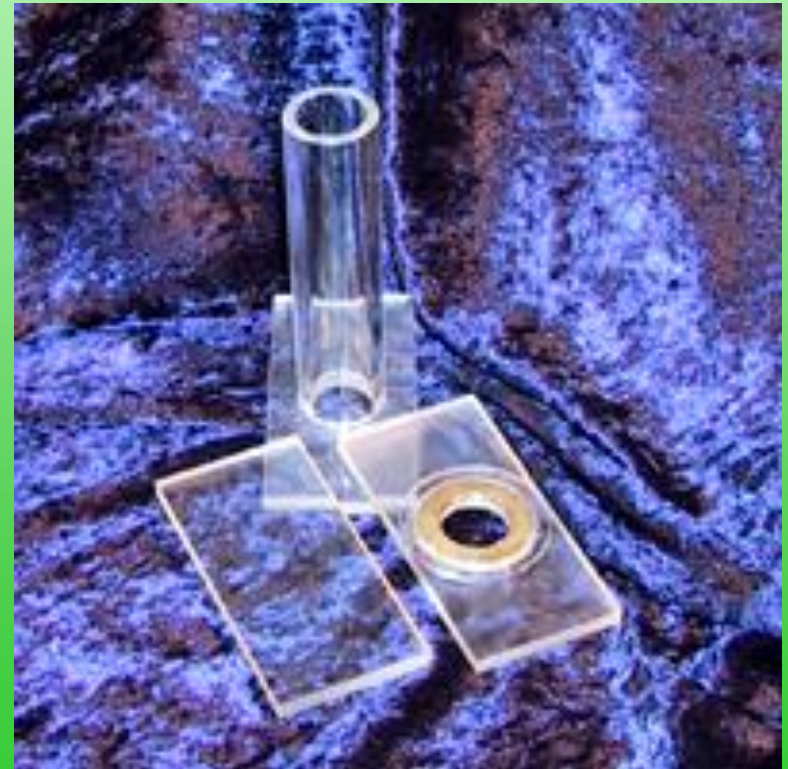

Algal Laboratory Methodology

Primary Optical Enhancements

- **Brightfield**
 - No enhancement, produces little detail, real color
- **Phase**
 - Uses annuli to scatter light at different angles through sample, all color distorted
- **Differential Interference Contrast (Nomarski DIC)**
 - Uses crystal prisms as beam splitters, eliminates halo effect get with phase contrast, looks 3D, good color
- **Epifluorescence**
 - Uses specified light wavelength to excite pigment or dye which then emits light back at a different wavelength

Algal Methodology

Bright Field

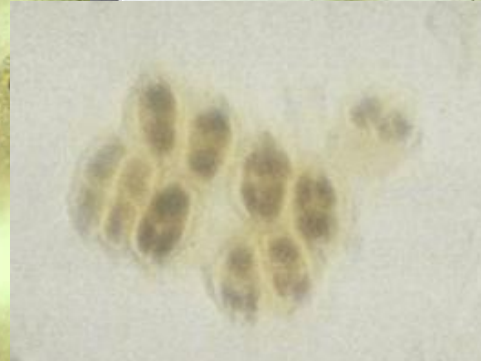
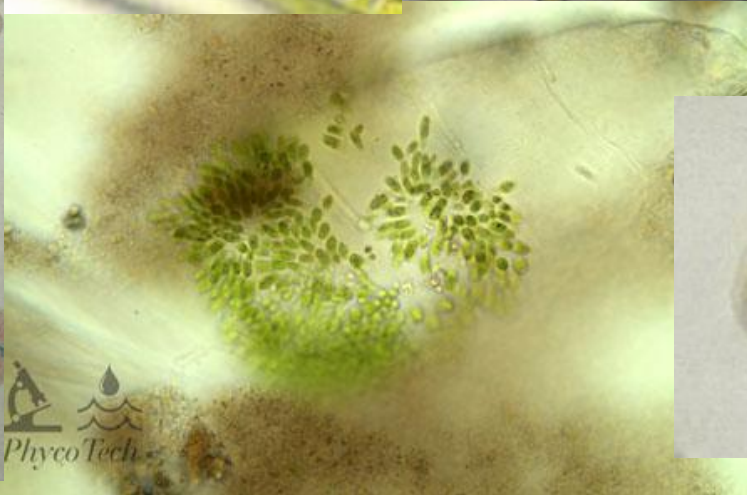
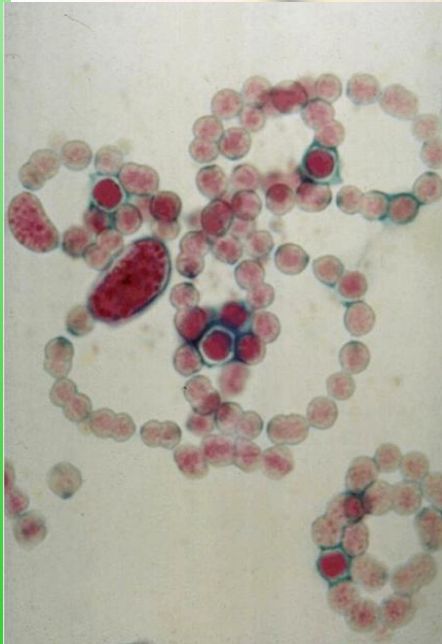
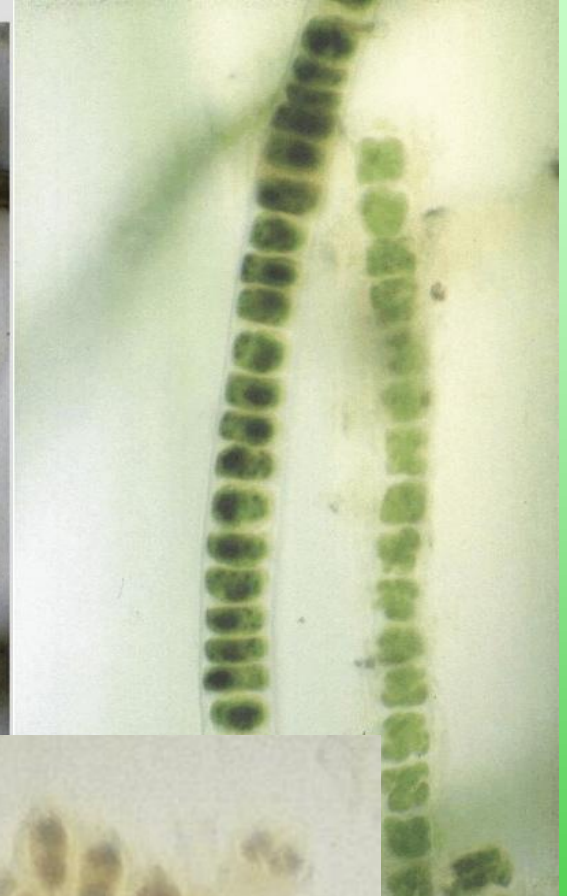
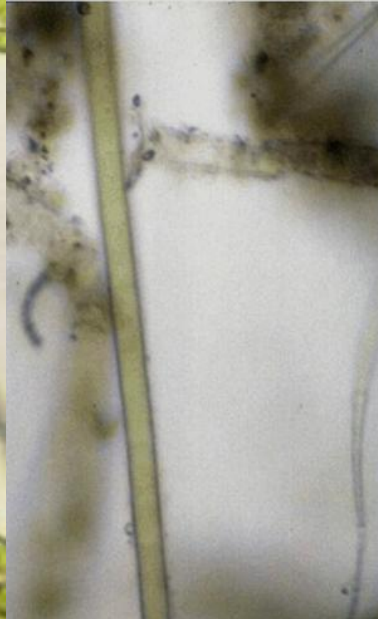
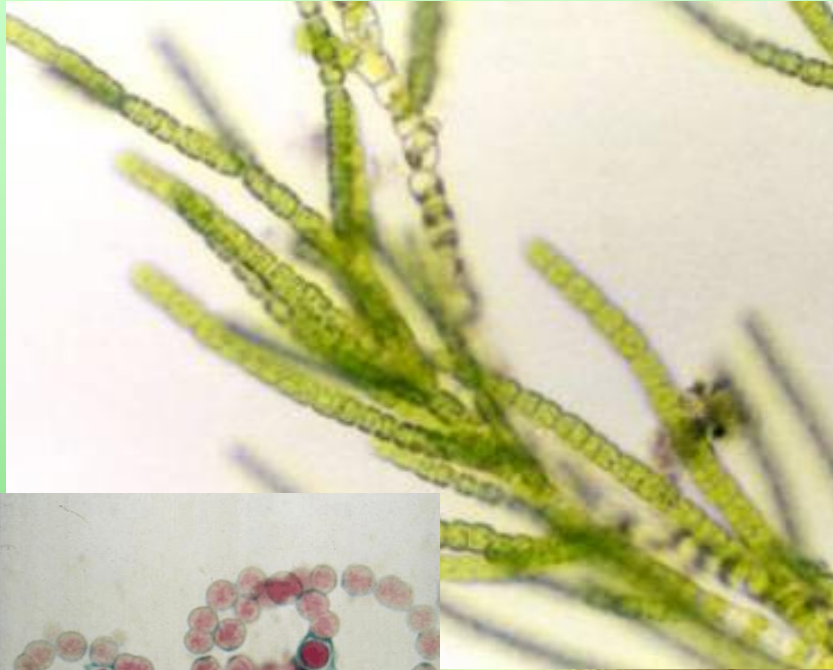

Algal Methodology

Phase

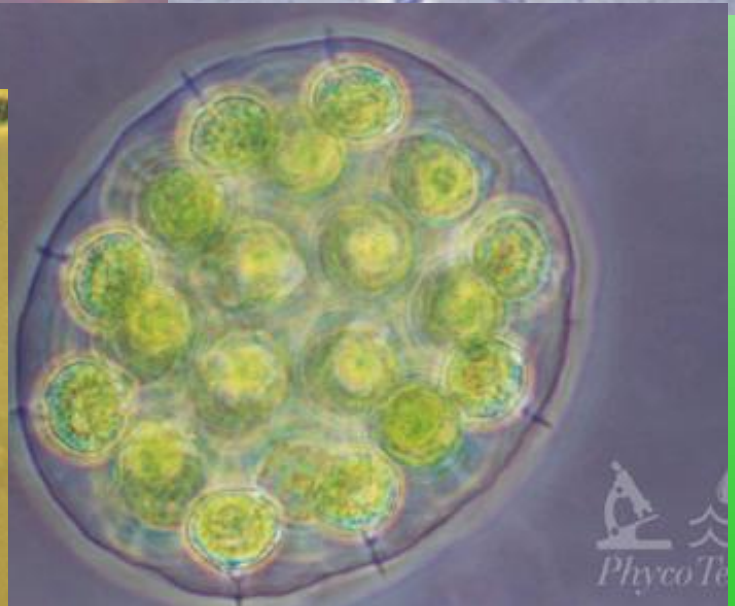
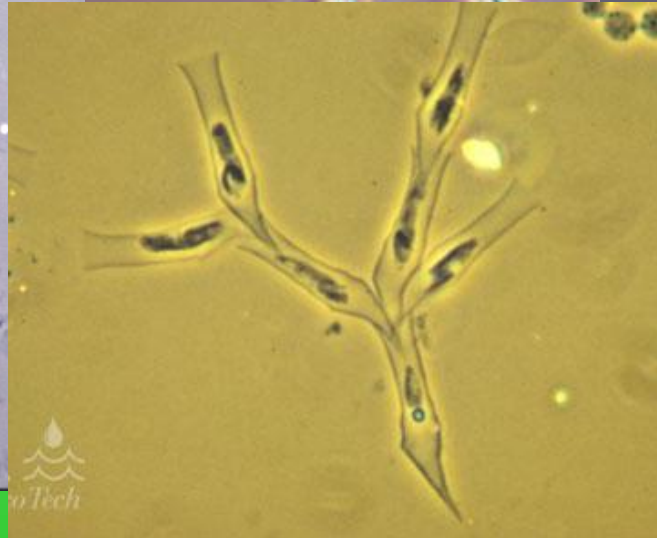
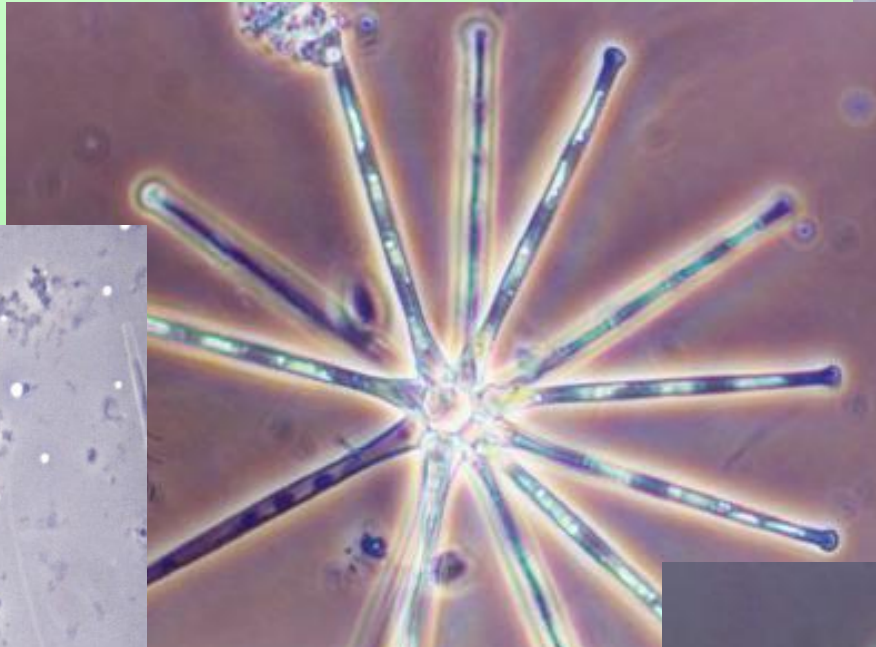

DIC

Algal Methodology

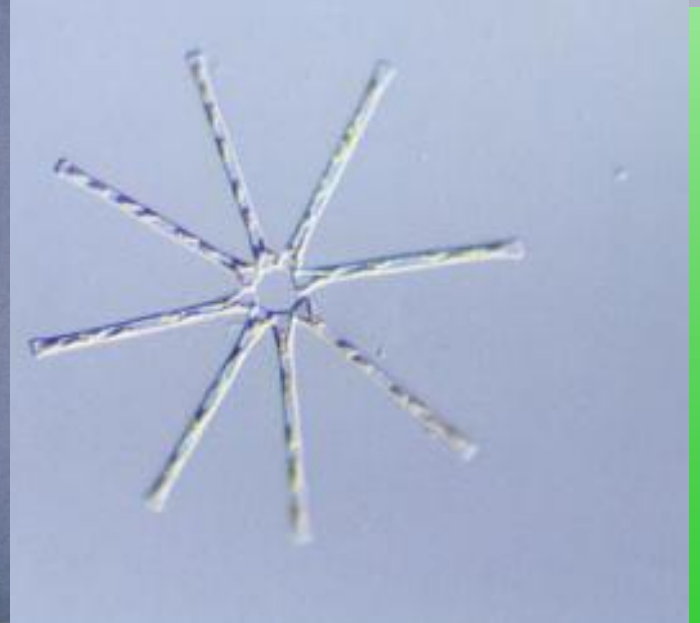
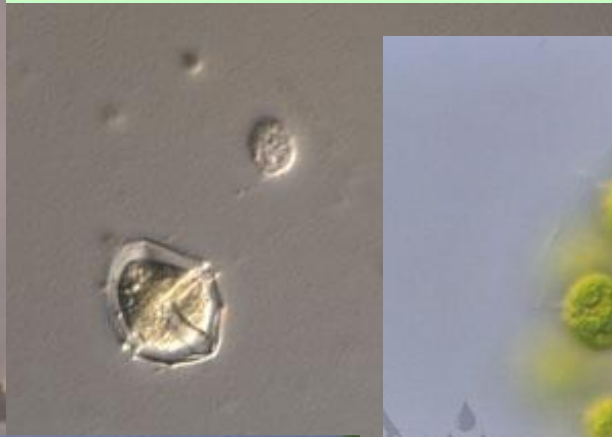

Algal Laboratory Methodology

Epifluorescence

- **Blue** excitation causes chlorophyll *a* to fluoresce back **red**.
- **Green** excitation causes phycoerythrin to fluoresce back bright **orange-red** and phycocyanin to fluoresce back **orange yellow**.

Algal Laboratory Methodology

Epifluorescence vs other optics

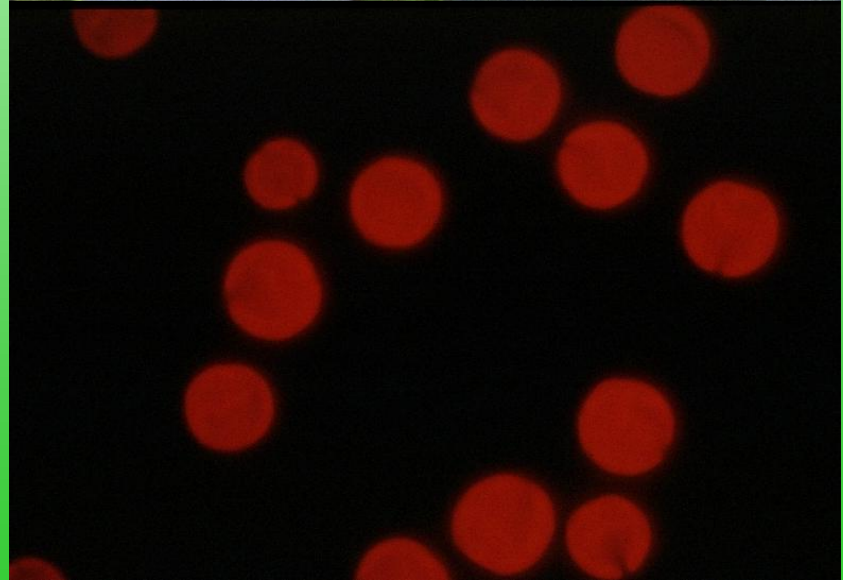
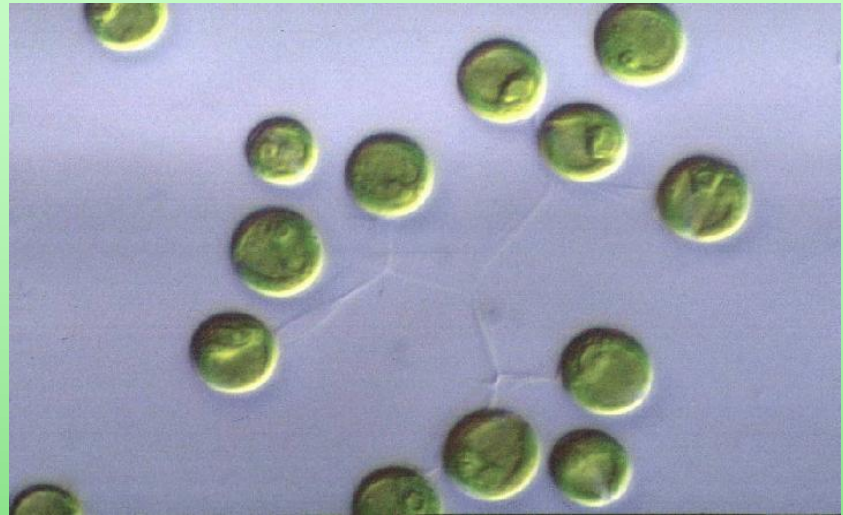
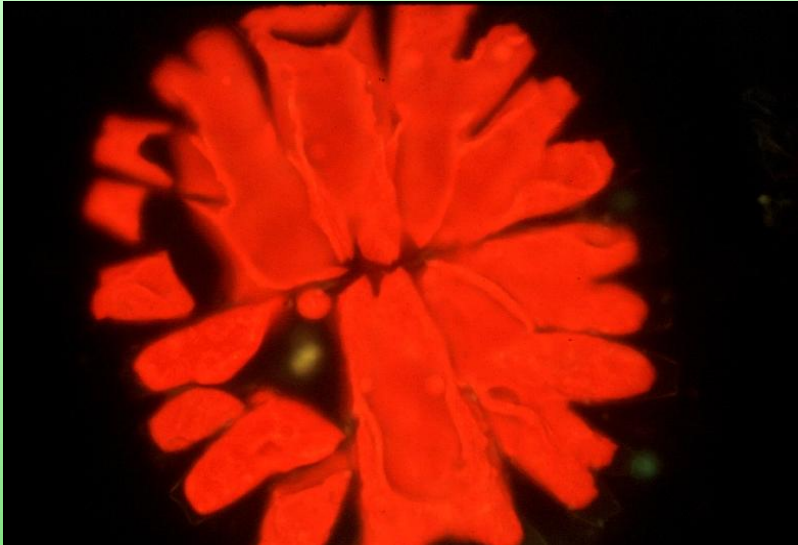

Algal Laboratory Methodology

**Epifluorescence
vs other optics**

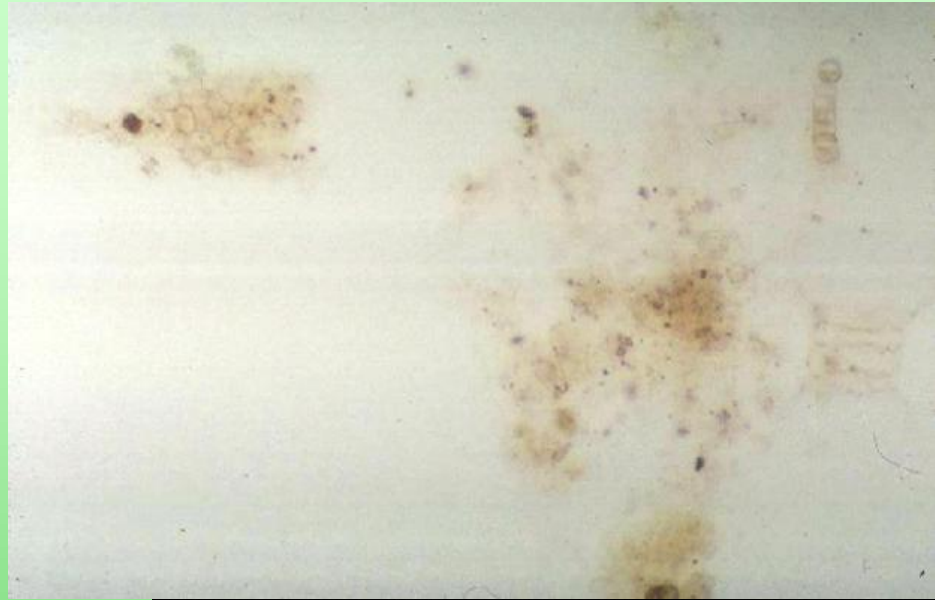

**Required for
picoplankton**



Algal Laboratory Methodology

Epifluorescence vs other optics

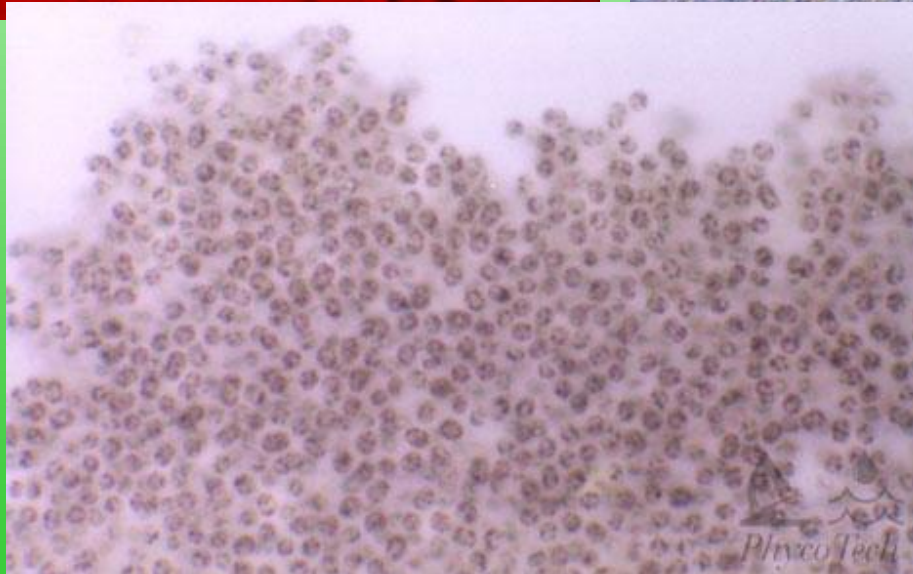
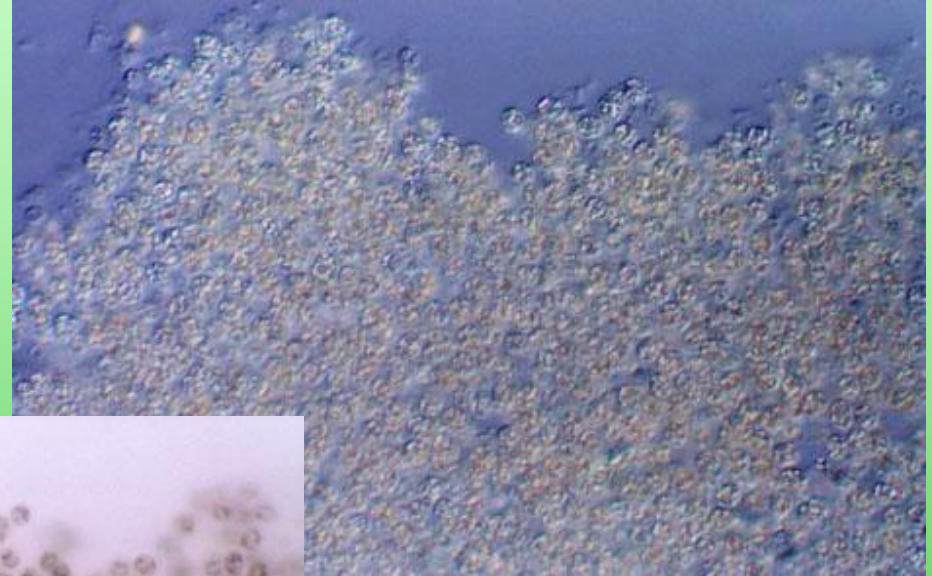
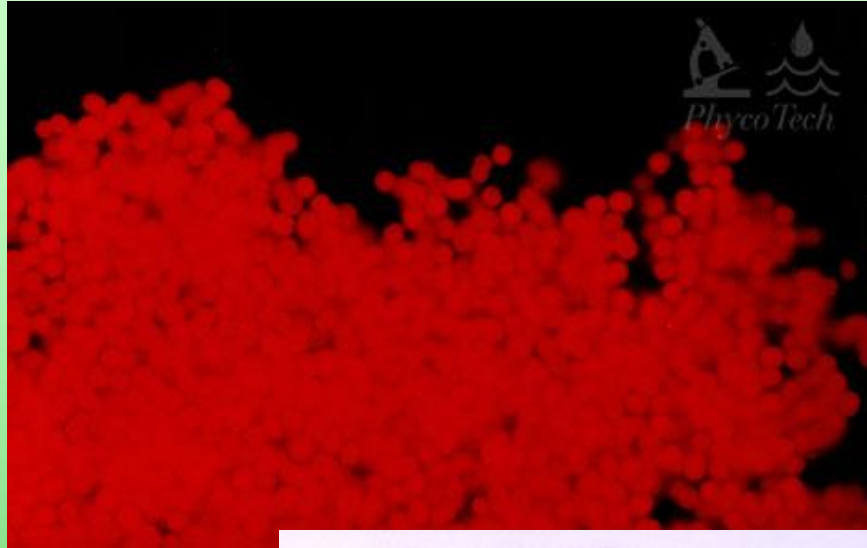

Algal Laboratory Methodology

Epifluorescence vs other optics

phycocyanin
vs.
phycoerythrin

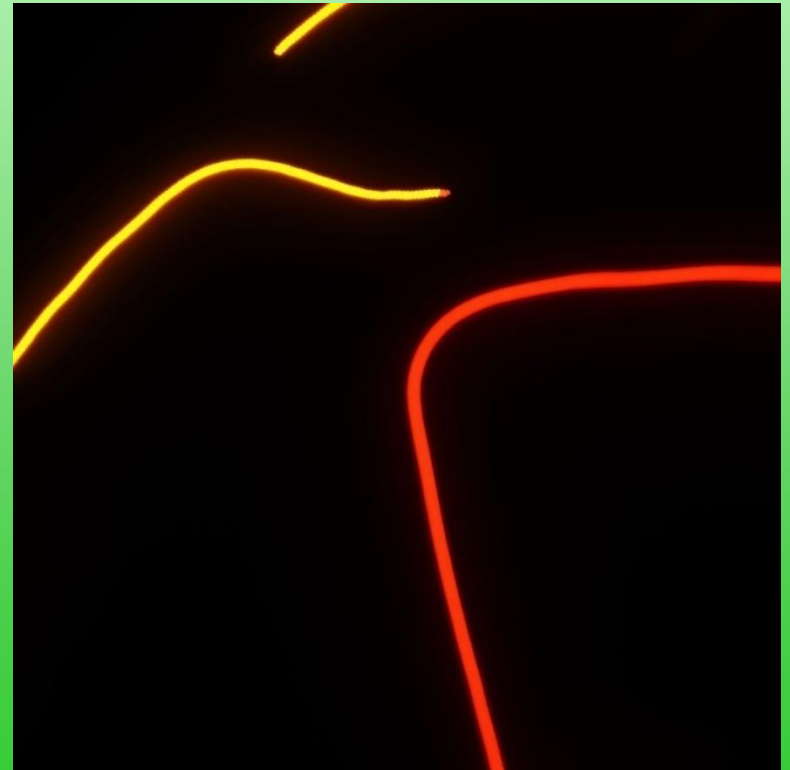
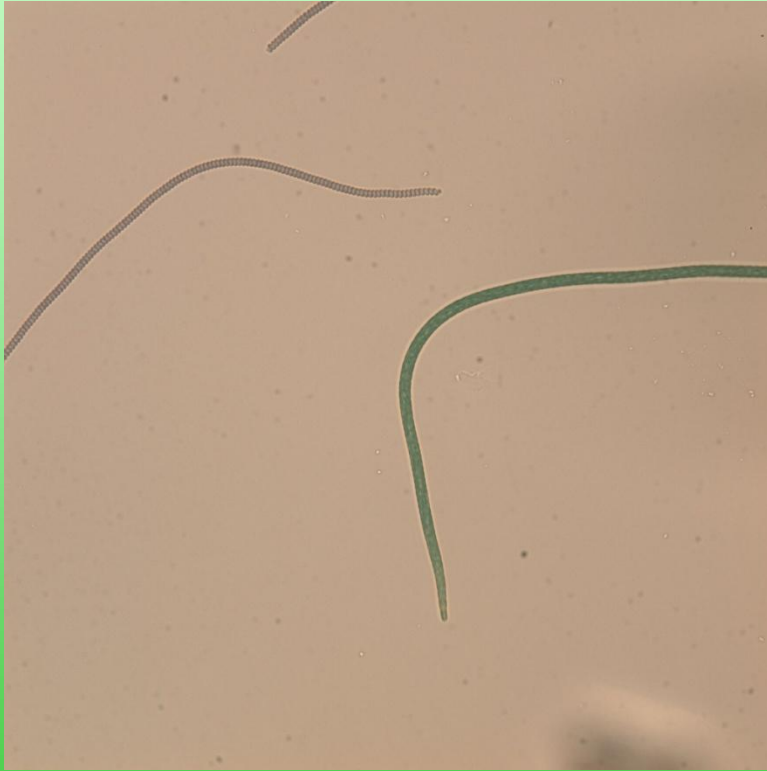

Algal Laboratory Methodology

Quantification

- Counting Unit
 - Natural units
 - Total cells
 - Areal standard units
- Precision vs. Accuracy
- Counting Method
 - Fields
 - Passes
 - Strips
 - Whole sample



Algal Laboratory Methodology

Quantification

- Biomass Estimates
 - Biovolume
 - Biomass (assume a specific gravity of 1)
 - Carbon estimates (based on biovolume)

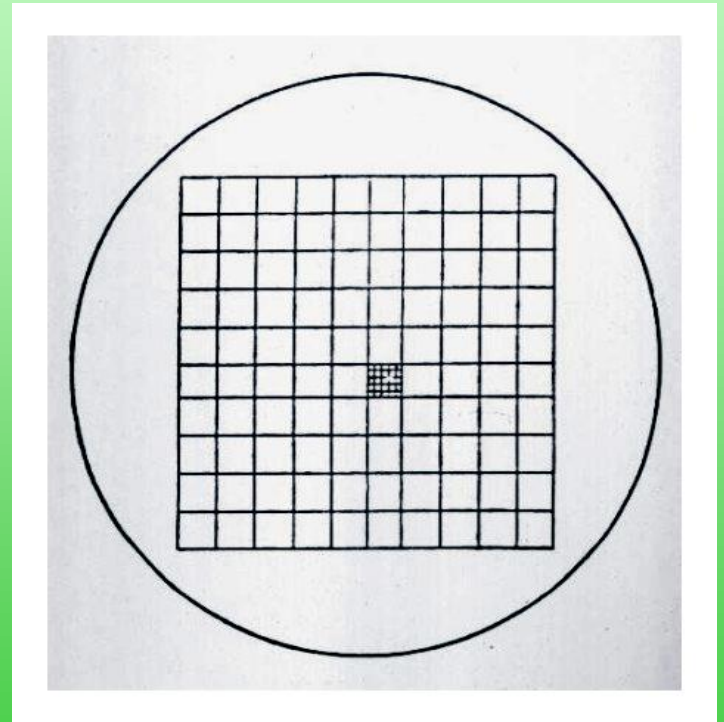

Whipple Grid

Algal Laboratory Methodology

Biovolume Estimates

- Allow you to estimate the importance of individual taxa based on size AND abundance
- Calculate the volume of living protoplasm based on common geometric figures
 - Cube, sphere, cone, cylinder, spherule
- Exclusive of sheaths, spines, setae
- **Everyone measures differently!**

Algal Laboratory Methodology

Shape Estimates

Sphere

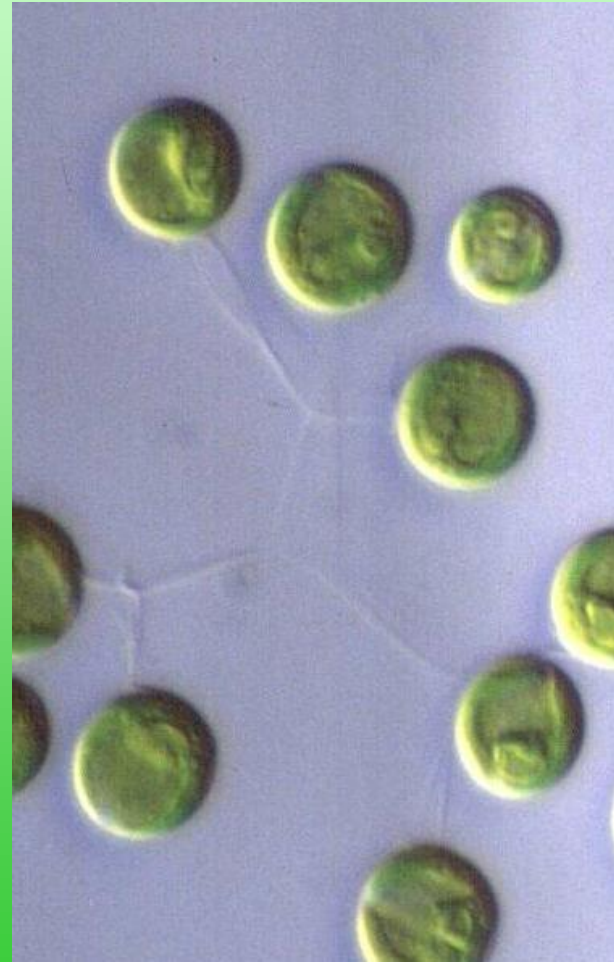
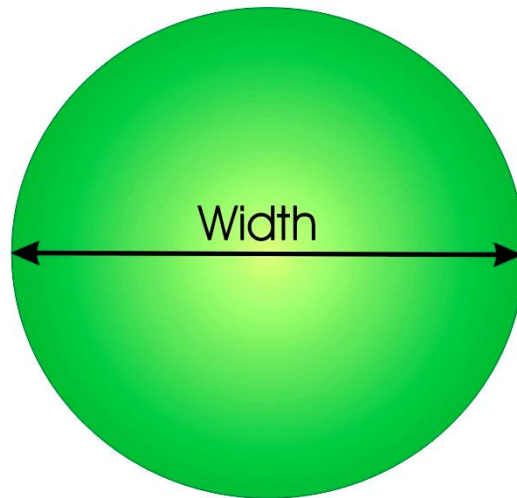

Algal Laboratory Methodology

Shape Estimates

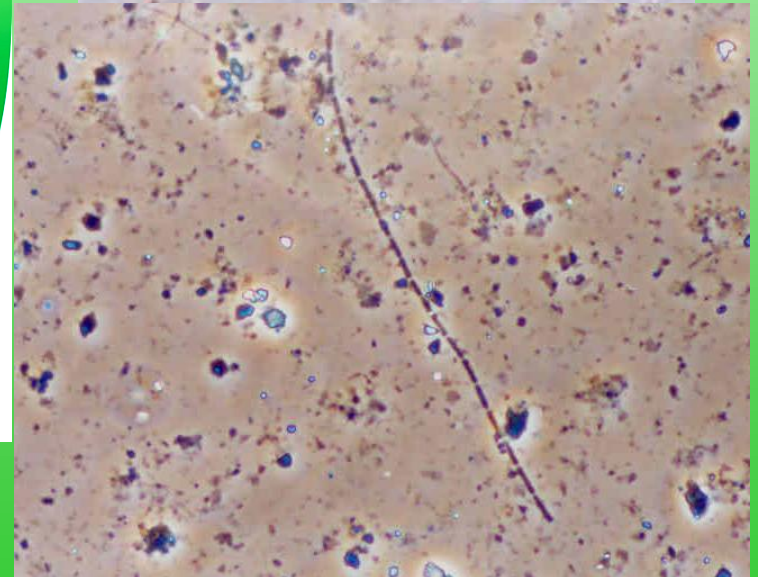
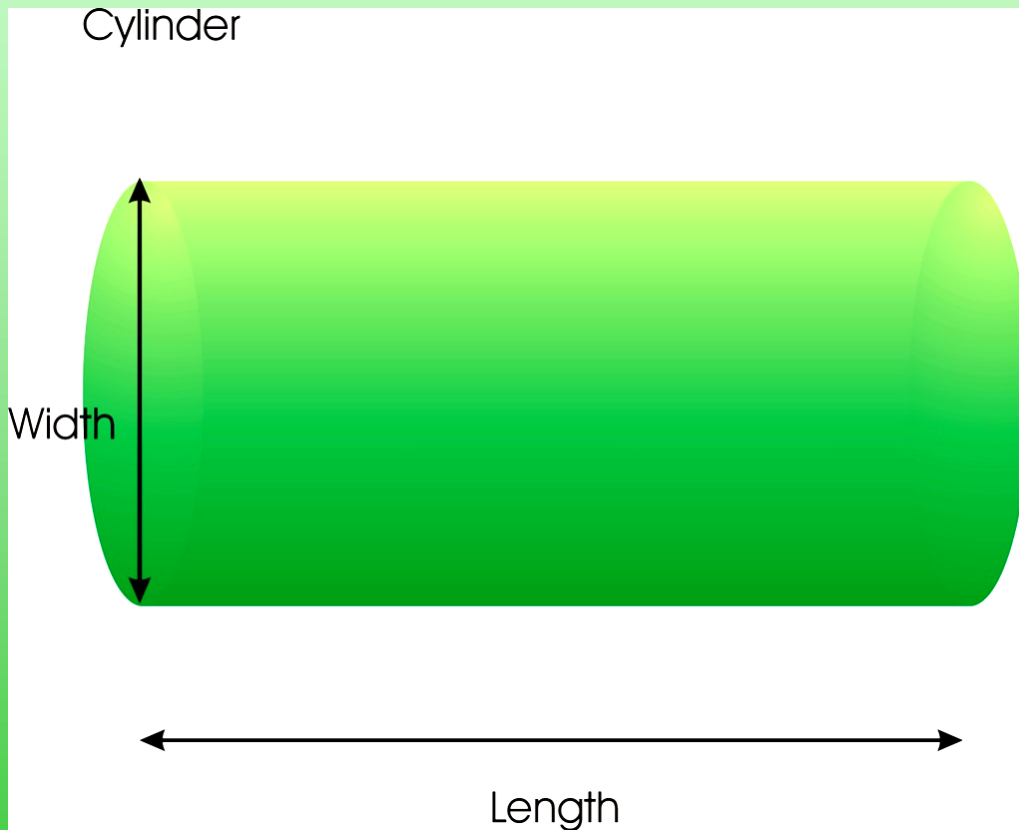

Algal Laboratory Methodology

Shape Estimates

Rectangular Box with Sheath

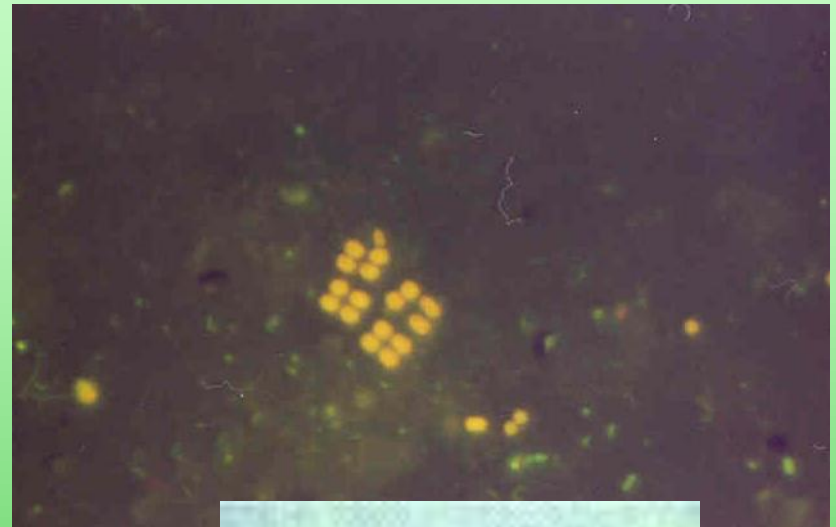
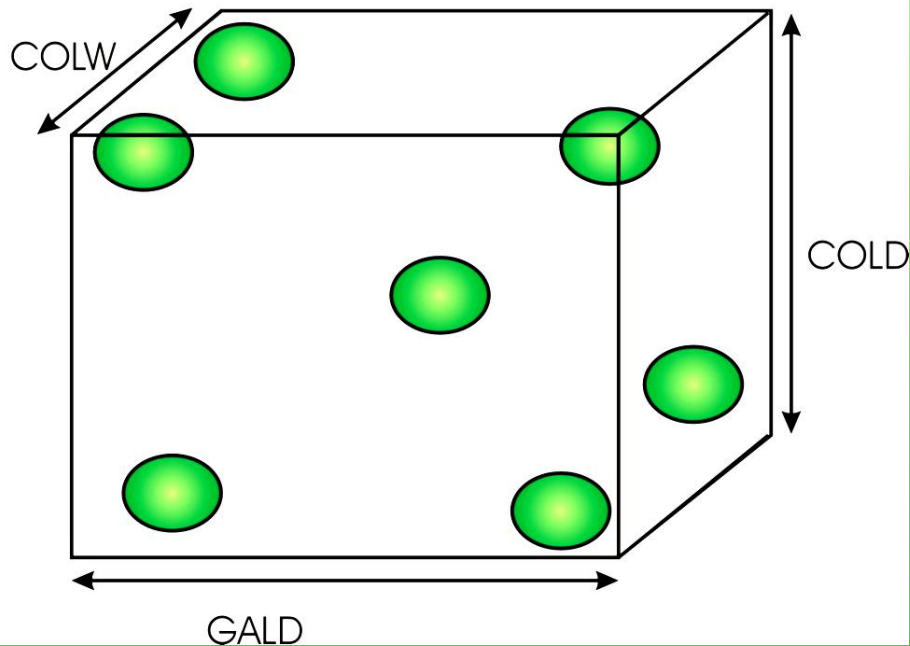

Algal Laboratory Methodology

Shape Estimates

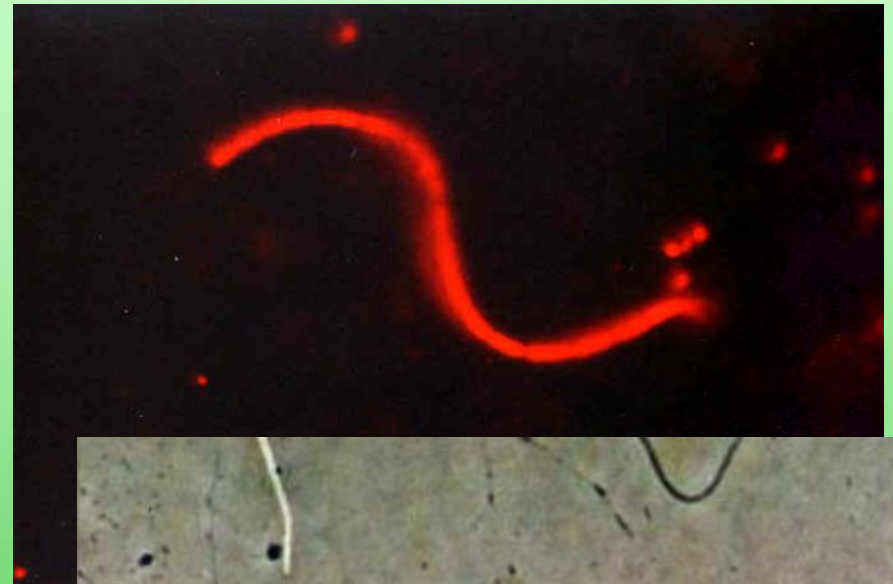
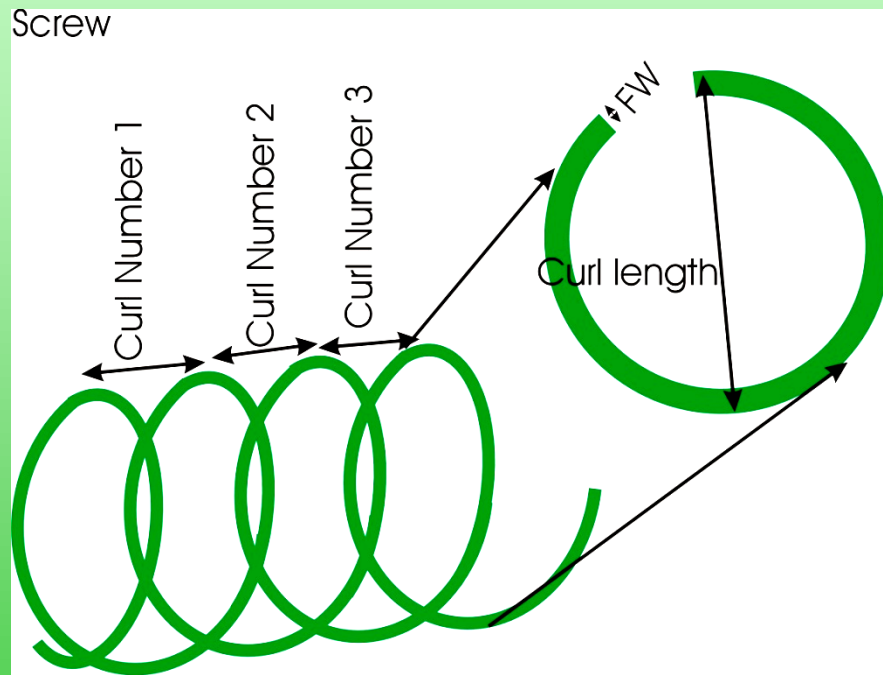

Algal Laboratory Methodology

Shape Estimates

**Different growth forms,
same taxon!!!**



Algal Laboratory Methodology

Quantifying Algae

Evaluation of Quantity

- Depends upon units of measure
- Depends on counting threshold, 100 NU-80%, 400 NU 90%
- Can have data in cells, areal units, natural units, or biovolume/biomass per unit volume
- May also have pigment (usually chlorophyll) data
- Filter run times may be a useful measure in water supply
- Some knowledge of algal types (quality) is essential

Algal Laboratory Methodology

Quantifying Algae

Limitations on Quantitative Relationships

- Variable cell size affects interpretation
 - **Everyone measures differently!**
- Chlorophyll per unit of algae varies with division, species, cell health, and phase of growth
- Ash-free dry weight to chlorophyll a ratio varies from 50:1 (healthy greens) to 300:1 (many blue-greens) – average is about 100:1

Algal Laboratory Methodology

Quantifying Algae

Bar graph for showing assemblages over time

Concentration - Station 1

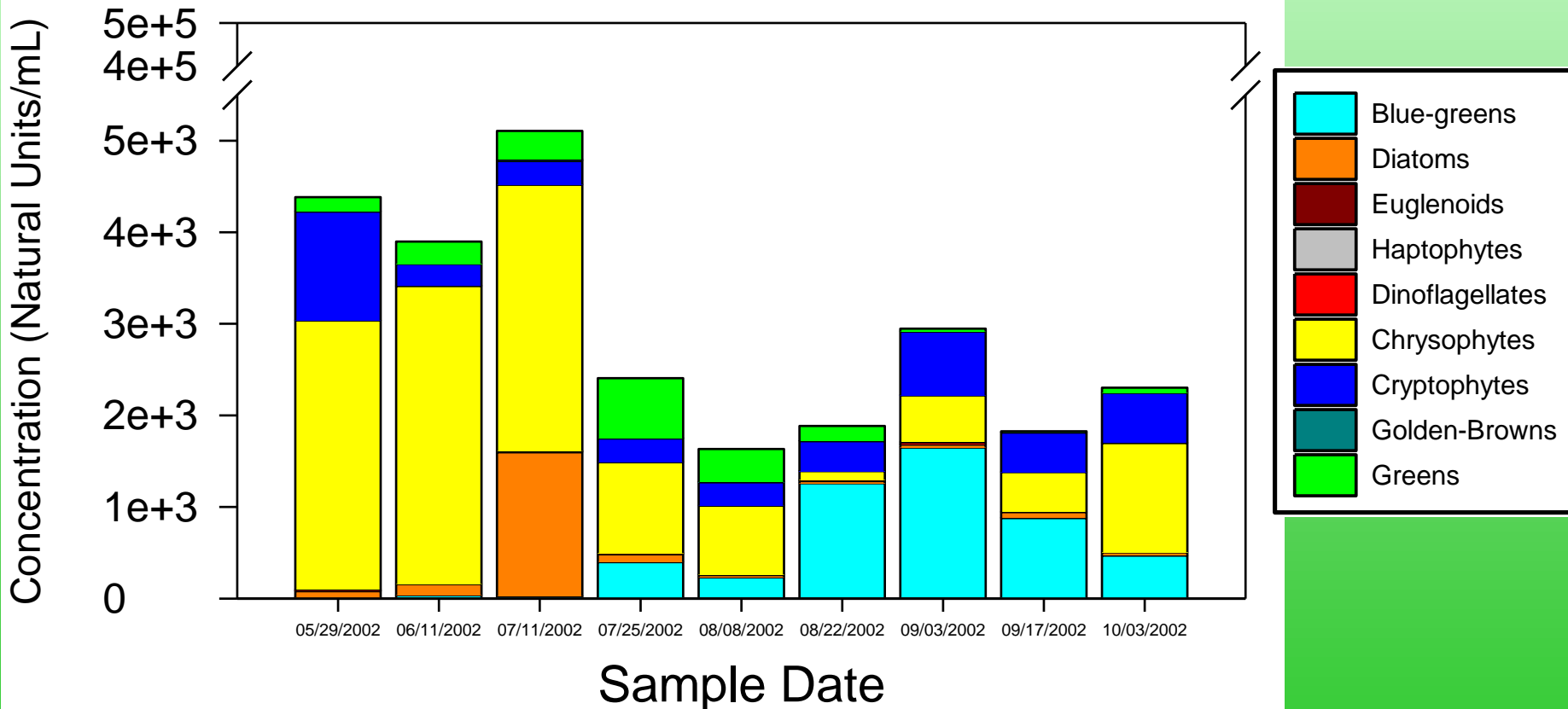

Algal Laboratory Methodology

Quantifying Algae

Percent Algal Abundance by Division -1

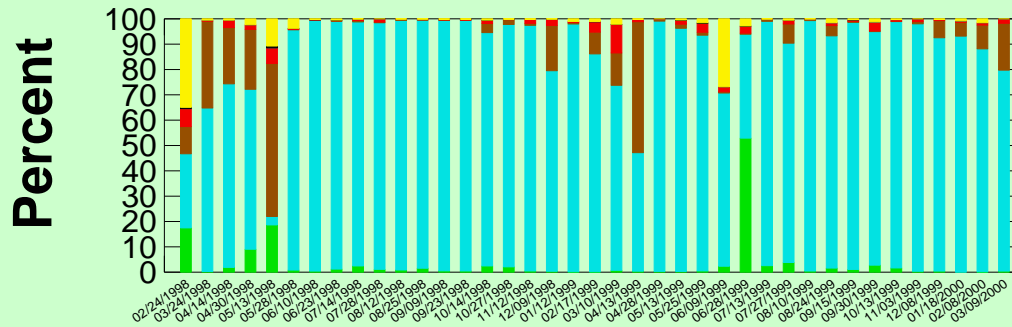

Percent Algal Biovolume by Division -1

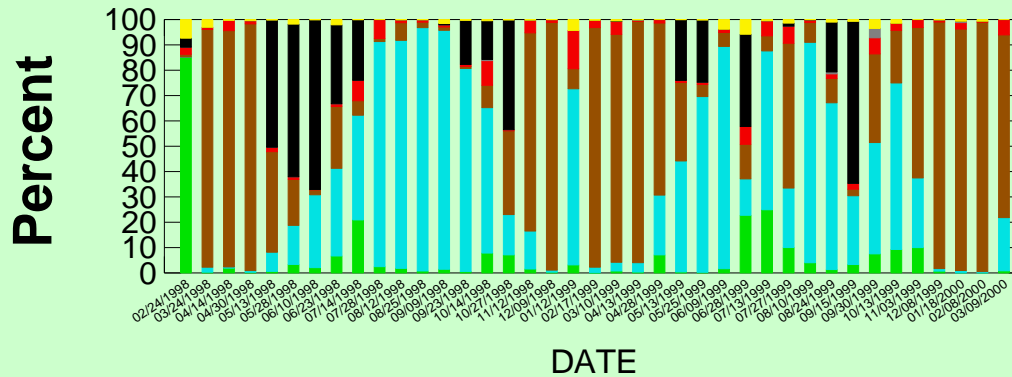

DATE

Algal Laboratory Methodology

Quantifying Algae

Area graph for showing assemblages over time –
NOT continuous data, can't express as solid
fill....

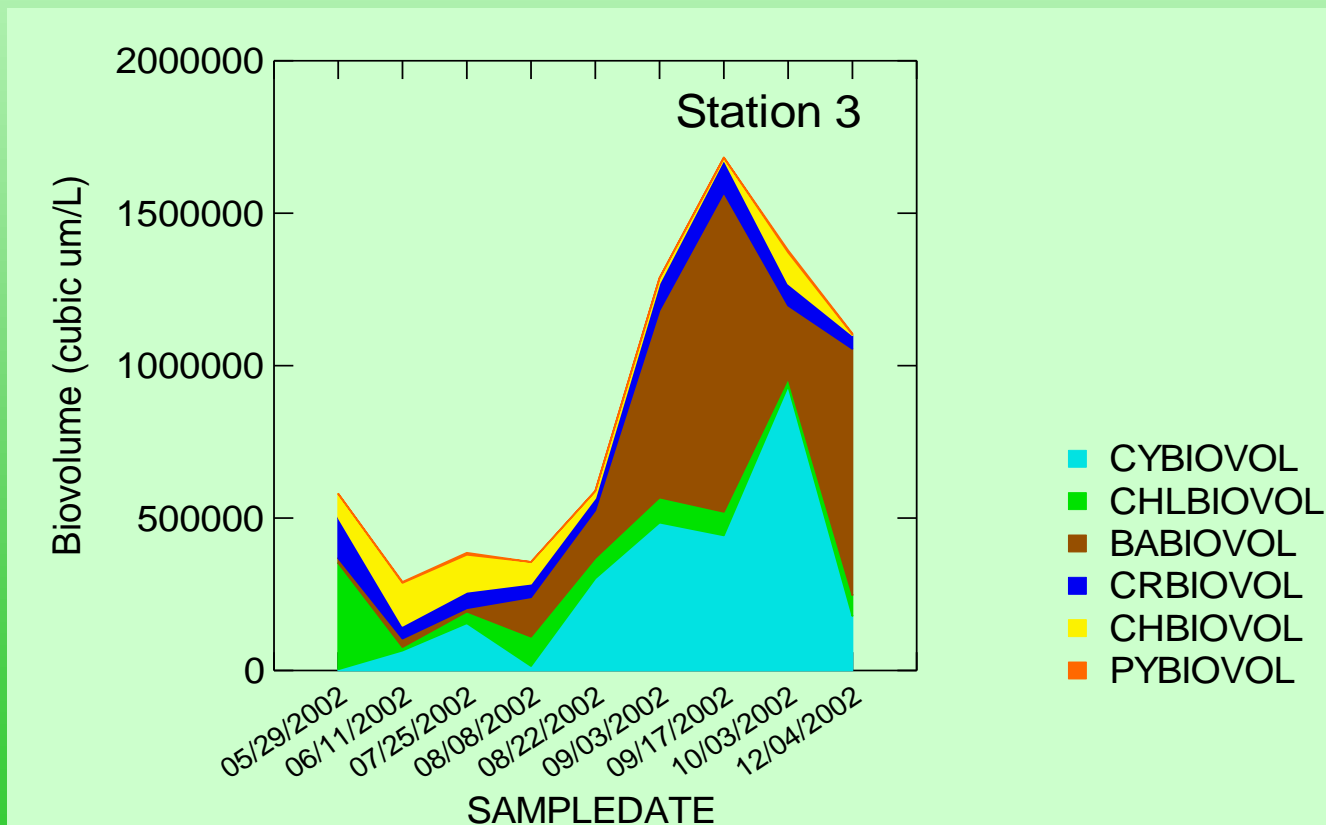

Algal Laboratory Methodology

QA/QC

- **Sample Collection Methods**
 - True Replicates
 - Pseudo-replicates
- **Sub-sampling**
 - Multiple chambers/mounts (at least 3)
- **Counting Methods**
 - Threshold
 - Time, Cells encountered, **NU** encountered (100, 400, 600, 800, error on slide) or combination
 - Fields/strips/whole slides
 - Magnification
- **Measurement Methods**
 - 10-15 of each taxa
 - Entire assemblage
 - NU, Cells or both – **NEVER mix and match**
- **Identification preferences/skill**
 - Fatigue

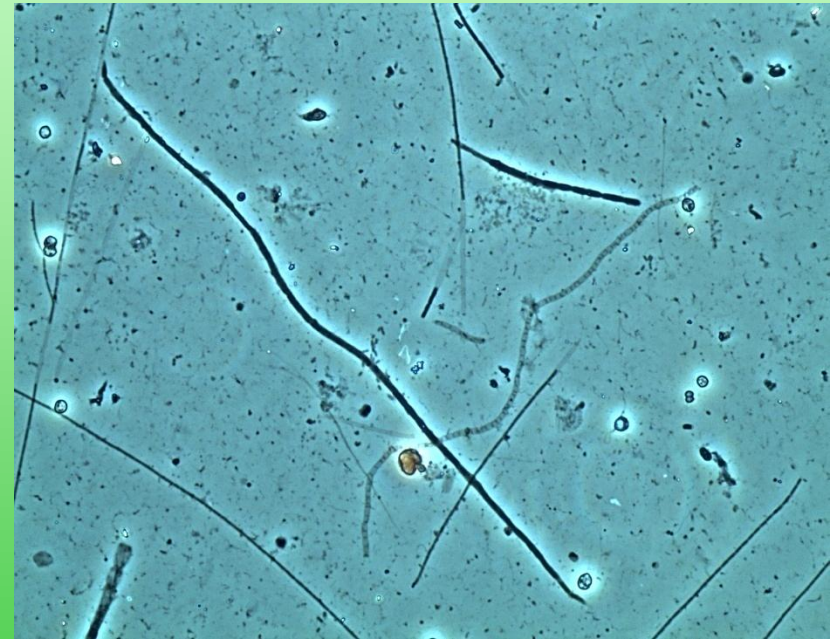

Algal Laboratory Methodology QA/QC

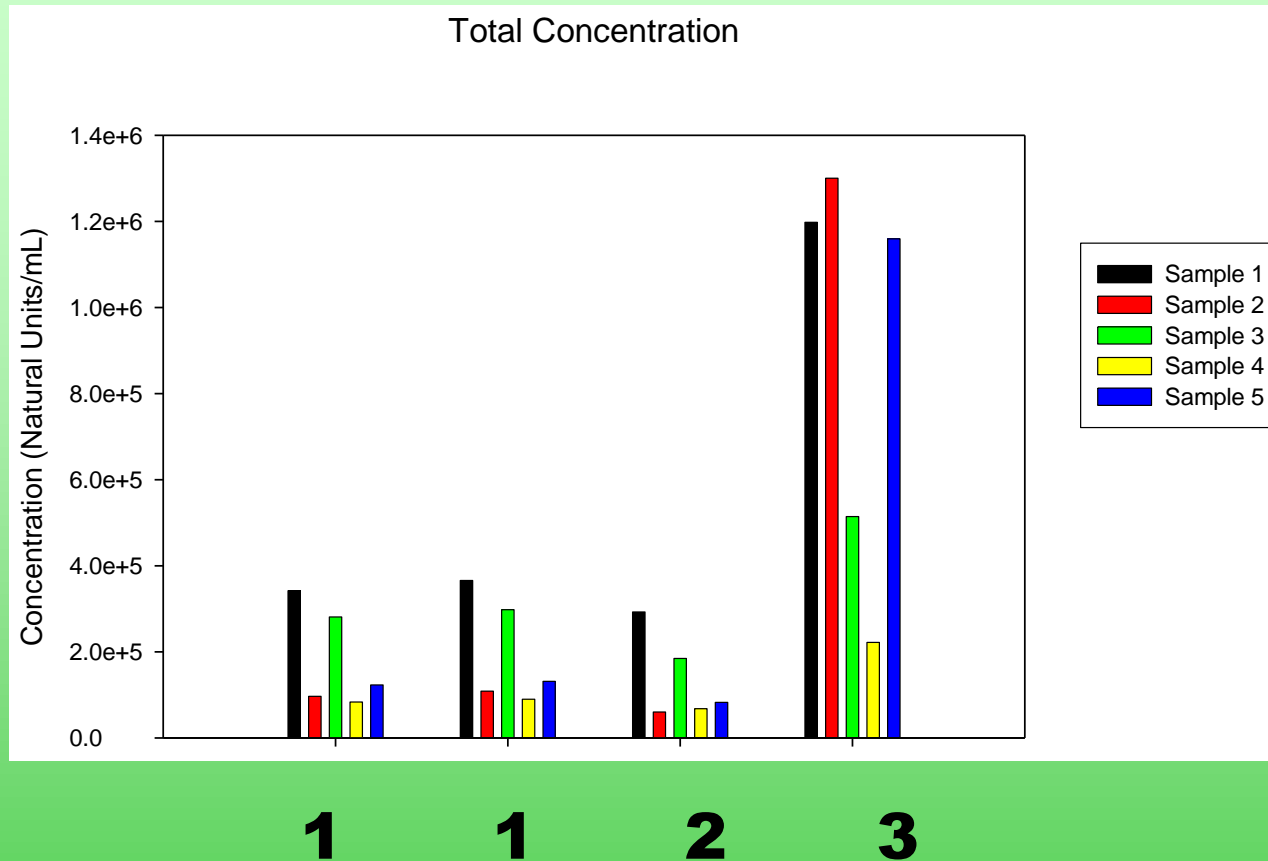

Look for consistency among taxonomists:

✓ Stations in same relative order

✓ Same list of dominants

✓ Total numbers within 20-30%, 10% is VERY difficult to meet when using different mounting and counting methods

Algal Laboratory Methodology

QA/QC

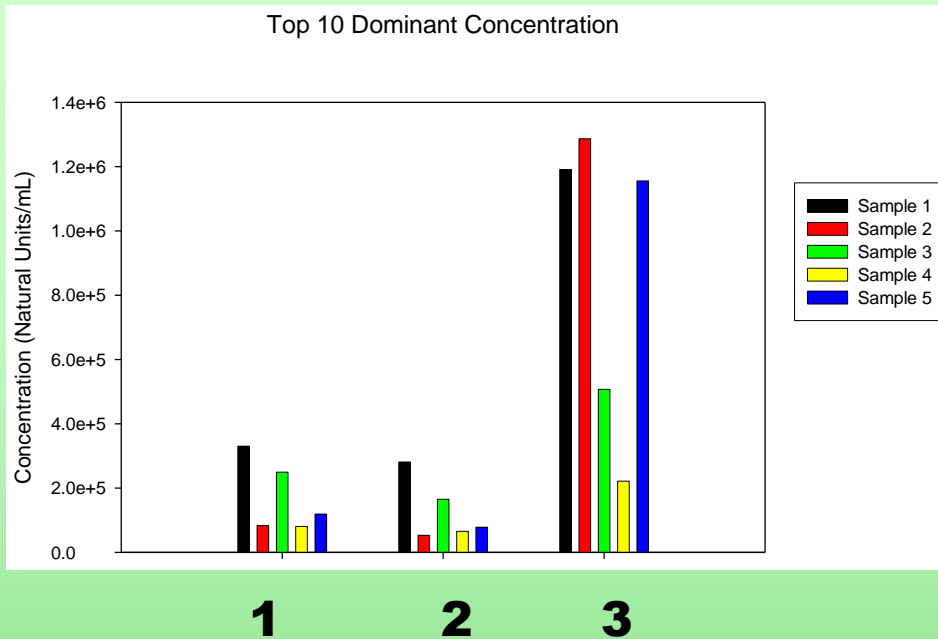

- Difference between counters can be substantial, even with acceptable technique
- Difference between units of measurement can also be substantial, just by nature of measurement, but also by variation among counters

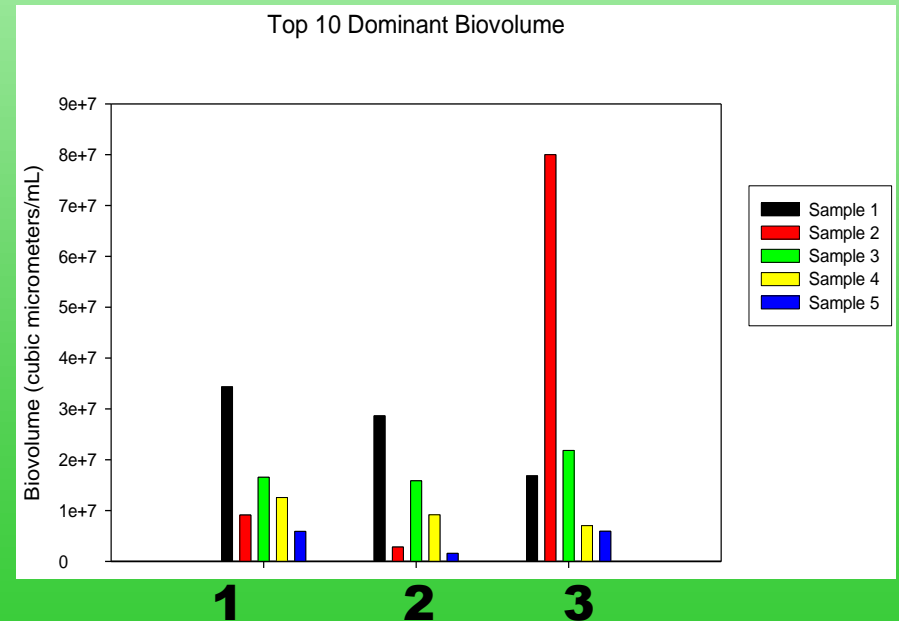

Algal Laboratory Methodology

QA/QC

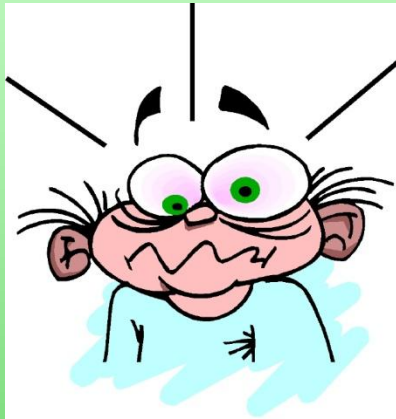

Mixing Natural Units and Cells during counting and data reporting confuses analysis.....is this a true difference or a mis-report of cells as NU?

Cylindrospermopsis raciborskii (Straight), Concentration

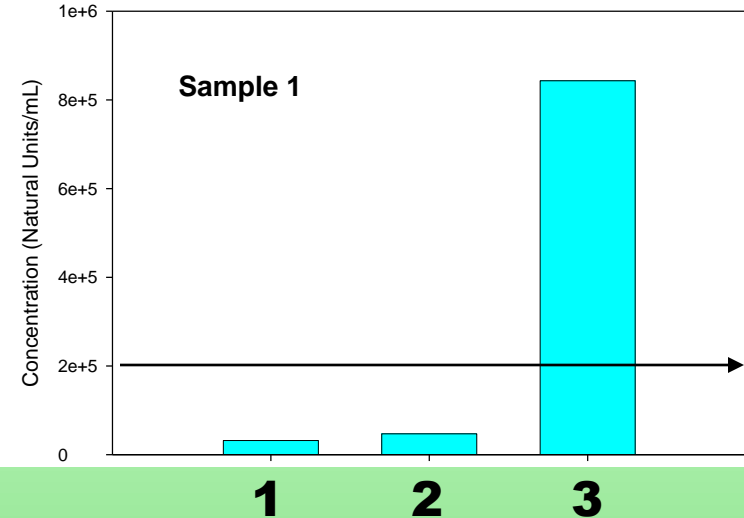

Cylindrospermopsis raciborskii (Straight), Biovolume

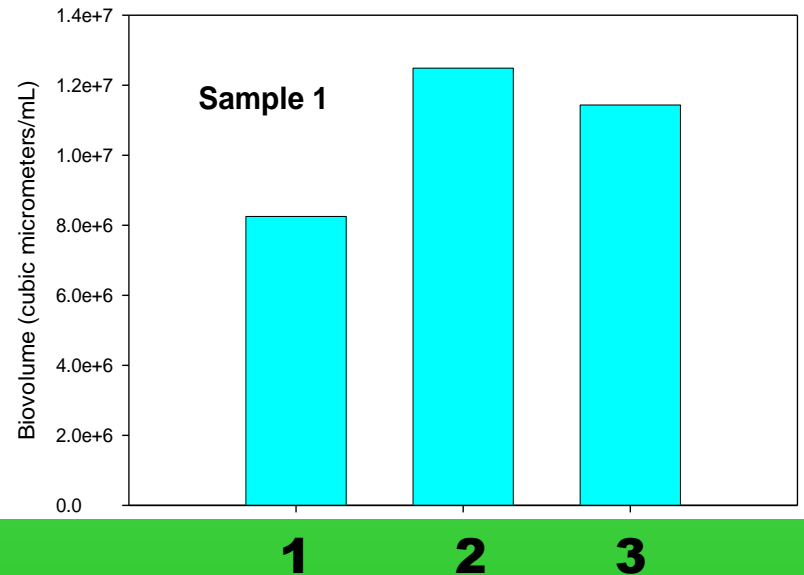

Algal Laboratory Methodology

QA/QC

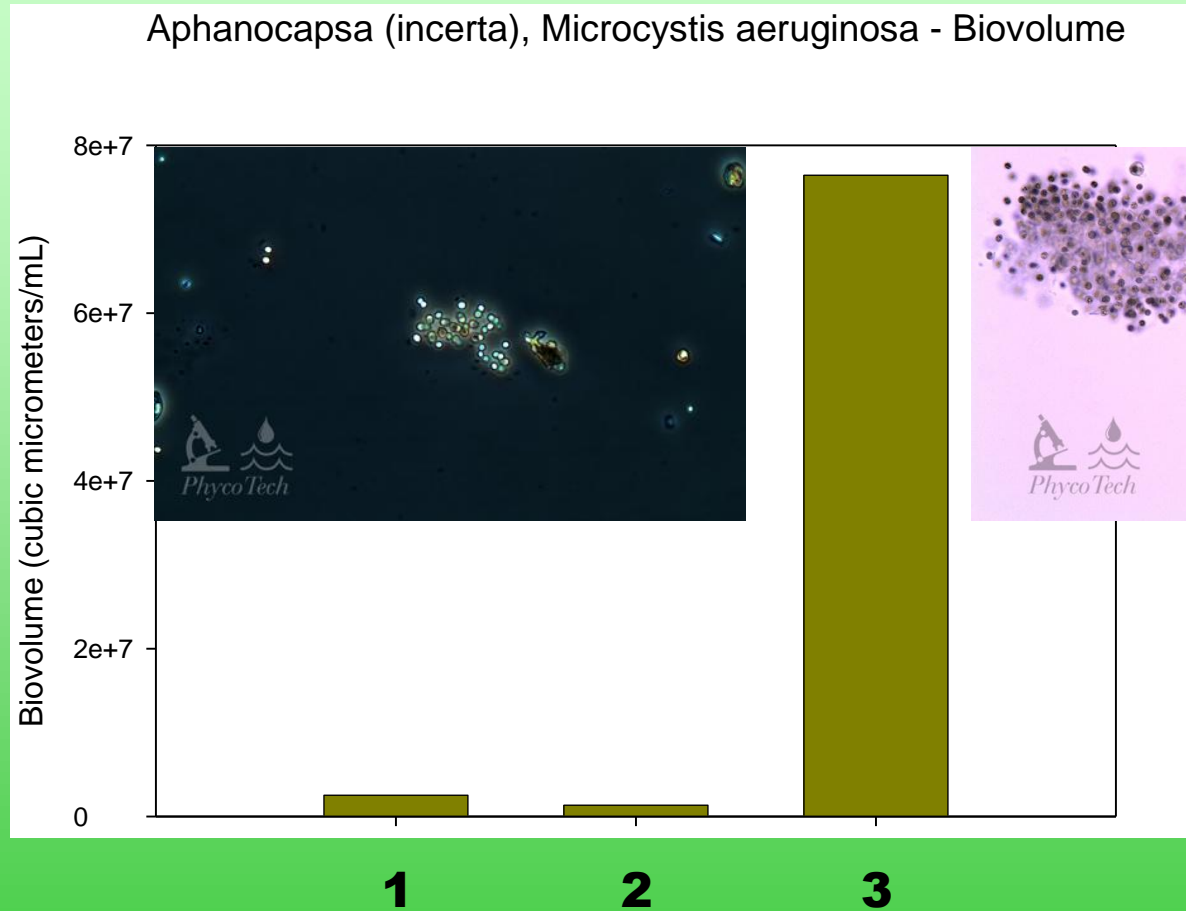

Identification Issues- Toxic Microcystis or Aphanocapsa?

Algal Laboratory Methodology QA/QC

- **Taxonomic consistency trumps true taxonomic accuracy if ecological interpretation or risk assessment does not change!**
 - As long as well documented and still meet project goals
 - If you must change, side by side QA/QC recommended for at least a season if you can (year is better)

Algal Laboratory Methodology

Quantifying Algal Quality

- **Dominance**
- **Richness**
- **Diversity**
- **Quality Indices**

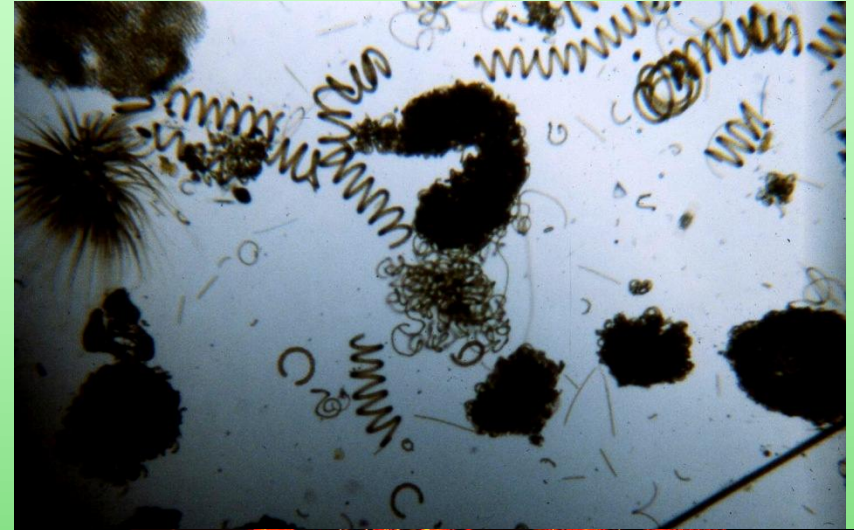

Algal Laboratory Methodology

Quantifying Algal Quality

Programs using entire assemblage

- **Primer E**
- **PC Ord**

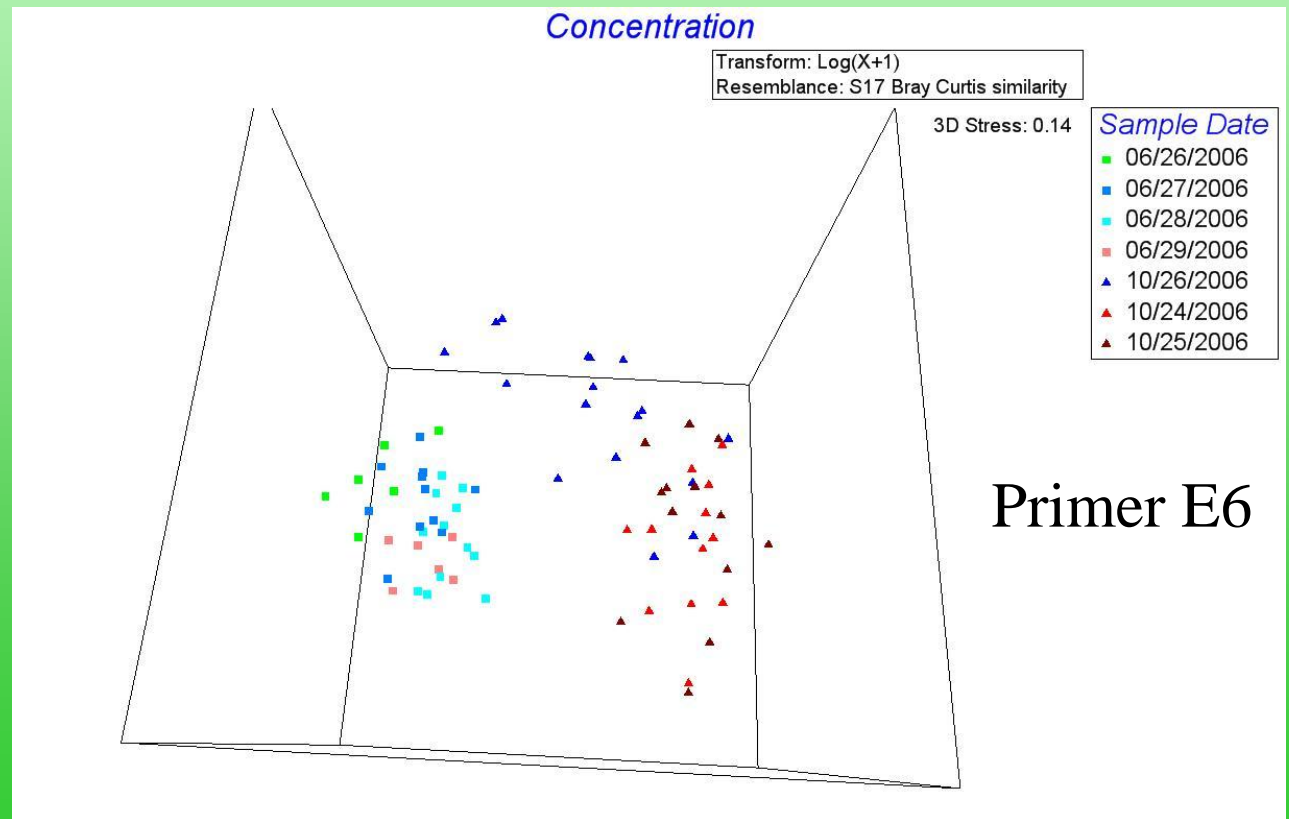

Algal Laboratory Methodology

Quantifying Algal Quality

Richness as an indicator of quality

- Richness usually relates more to counting effort than to ecological indications. 10 - 25 normal without great effort, high sample concentration, and/or lots of taxa at low abundance.
- Richness depends on level of taxonomic separation; more taxa (higher richness) with more detailed identification.
- With consistent effort, higher richness should be an indication of higher diversity.
- Presence/absence data at the genus/species level can be used to determine the similarity of samples

Algal Laboratory Methodology

Quantifying Algal Quality

Diversity as an indicator of quality – Part I

- Measures the distribution of numbers over the number of taxa present; highest when numbers evenly distributed among taxa.
- Higher diversity usually taken to indicate more desirable ecological conditions, but concept is controversial.
- Low diversity indicates high dominance by one or a few taxa; conditions beyond dominance threshold(s).
- Proper diversity calculation varies with type of sample and approach to identification/enumeration.

Algal Laboratory Methodology

Quantifying Algal Quality

Diversity as an indicator of quality – Part II

- Expression of diversity as a function of maximum diversity possible for a given sample tends to minimize statistical artifacts, creates scale of 0-1, more easily comprehended.
- Rare species may be neglected in diversity indices, but can become important later in time.
- **Expression of detailed sample analysis as a single number oversimplifies community features and may not be dependable by itself.**

Algal Laboratory Methodology

Microscopy Educational Sites and Trouble Shooting Information

- **<http://www.mic-d.com/gallery/index.html>**
- **http://www.olympusamerica.com/seg_section/seg_faq.asp**
- **http://www.microscopy-uk.org.uk/full_menu.html**