

Handbook for Design:

Specially Adapted Housing for Wheelchair Users



VA Pamphlet 26-13
August 2009
Veterans Benefits Administration
Department of Veterans Affairs
Washington, DC 20420

Intention

This pamphlet provides assistance to the physically handicapped veterans, servicemembers and to architects/designers in producing the best possible home for veterans and servicemembers. The Department of Veterans Affairs (VA) hopes that the information presented in this pamphlet will increase the architect's or designer's sensitivity to the needs of the veteran or servicemember and facilitate awareness of the design challenges faced. Most of the criteria presented in this pamphlet relate to detailed design issues. Though many of these details are critical to function, the recommendations presented are not intended to unnecessarily restrict the architect's or designer's overall freedom of design. Because each veteran or servicemember has unique needs and there is a wide range of possible designs, it is difficult to formulate universal design requirements. Much of the information presented here should be viewed as recommendations. Specific requirements for specially adapted housing and special housing adaptations are outlined in VA Manual M26-2, Specially Adapted Housing Grant Processing Procedures, and VA Pamphlet 26-69-1, revised, Questions and Answers on Specially Adapted Housing and Special Housing Adaptations. The final design should not call undue attention to the necessary design features, but be noteworthy only for its architectural excellence.

Use

This pamphlet allows for quick reference to specific areas of design. We recommend the designer read the entire pamphlet to become familiar with the total spectrum of the veteran's and servicemember's needs. This pamphlet should then be reviewed with the veteran or servicemember to determine which recommendations are applicable to his/her individual needs. All critical dimensions, such as wheelchair size, turning radius, or the individual's reach, must be verified on an individual basis.

Feedback

VA encourages feedback from any source in the form of suggestions, corrections, and criticism. Such input updating and improvement of this pamphlet and the overall quality of veterans' homes. Acknowledgement will be given for any suggestion adopted for publication. Responses should be directed to the Department of Veterans Affairs, Veterans Benefits Administration (262), 810 Vermont Avenue, Washington, DC 20420.

Acknowledgements

Thanks to Carol Paredo Lopez, AIA, Paralyzed Veterans of America, for reviewing this pamphlet.

Contents

Section 1: Introduction

1.1. Wheelchair Dimensions	2
----------------------------------	---

Section 2: Site Considerations and Outdoor Design

2.1. The Site	8
2.2. Walks and Ramps	10
2.3. Handrails	12
2.4. Entrances	14
2.5. Garages	16

Section 3: Floor Plans

3.1. General Considerations	20
3.2. Bedrooms	22

Section 4: Interior Details

4.1. Door Operations	26
4.2. Doors	28
4.3. Windows	30
4.4. Wall Switches and Electrical Outlets	31
4.5. Corridors	33
4.6. Closets	34
4.7. Stairs	35

Section 5: Bathrooms

5.1. Bathroom Design	38
5.2. Bathroom Fixtures	40
5.3. Transfer Techniques	43
5.4. Bathtubs	45
5.5. Showers	47

Section 6: Kitchens

6.1. Kitchen Design	50
6.2. Work Areas	52
6.3. Kitchen Sinks	54
6.4. Ovens	56

Section 7: Safety

7.1. Safety Considerations	60
----------------------------------	----

Metric Conversions	61
---------------------------------	----

Index	63
--------------------	----

Introduction

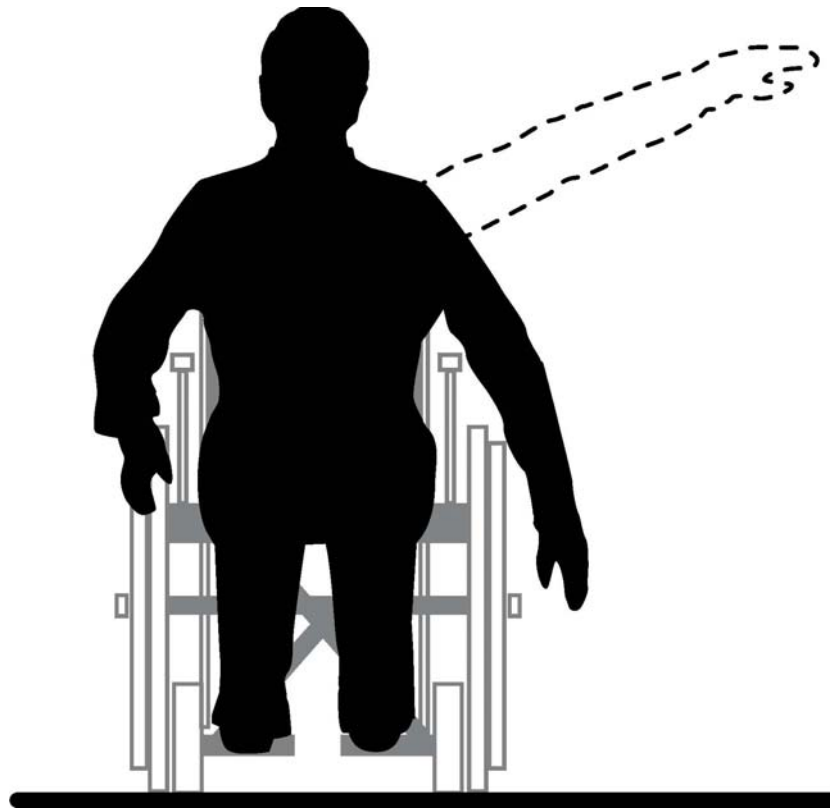

1.1 Wheelchair Dimensions

Most of the dimensions in this handbook are based on the needs of the wheelchair user. Because numerous models and sizes of wheelchairs are available, the dimensions listed accommodate the most commonly used chair—a non-motorized collapsible adult-size chair with propelling rear wheels, a tubular metal frame, and a plastic upholstered seat and backrest.

1.1.1. The width of the wheelchair is adjustable and is set to suit the user. The seat height varies slightly and may be altered by adding a cushion. The footrests may be fixed or adjustable. Many footrests are hinged to swing to the side, allowing the user to get closer to furniture and fixtures. The armrests of many wheelchairs can be removed, which allows for side and parallel transfers (see Figures 5.5 and 5.6). Most wheelchairs collapse to a width of approximately 11" for storage at home or in a vehicle. Attachments such as toilets and electric motors significantly increase the overall dimensions of a wheelchair.

1.1.2. The turning radius of a wheelchair depends on the length and width of the chair and the technique the user employs. The most common way to turn in a wheelchair is to simultaneously move one rear wheel forward and the other rear wheel backward, causing the wheelchair to pivot around its center. When turned in this way, the average wheelchair requires an area with a diameter of approximately 5'-0". A wheelchair can also be turned by locking one rear wheel and turning the other; this method increases the diameter of the turning space to approximately 6'-0". A wheelchair can be turned in a smaller space by a series of backing and turning moves.

NOTES:

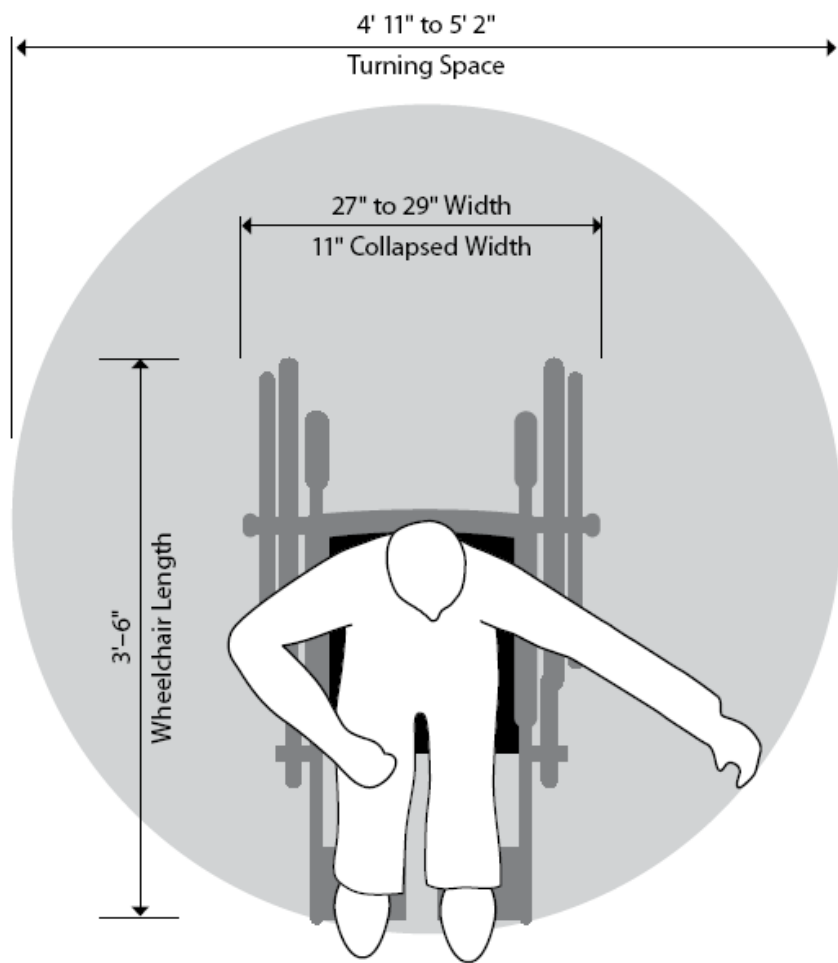

Fig. 1.1 Typical Wheelchair Dimensions

Typical Dimensions

WIDTH	<u>27" to 29"</u>
LENGTH	<u>3' 6"</u>
TURNING SPACE	<u>4' 11" to 5' 2"</u>

Actual Dimensions

WIDTH	_____
LENGTH	_____
TURNING SPACE	_____

1.1.3 When calculating the floor space needed to turn in a wheelchair, the designer should also consider the vertical characteristics of the wheelchair. For example, the height of the footrest (measured from the floor to the

top of the foot) is approximately 9". This measurement is important because the footrest and feet should pass under fixtures, such as lavatories, as the wheelchair rotates.

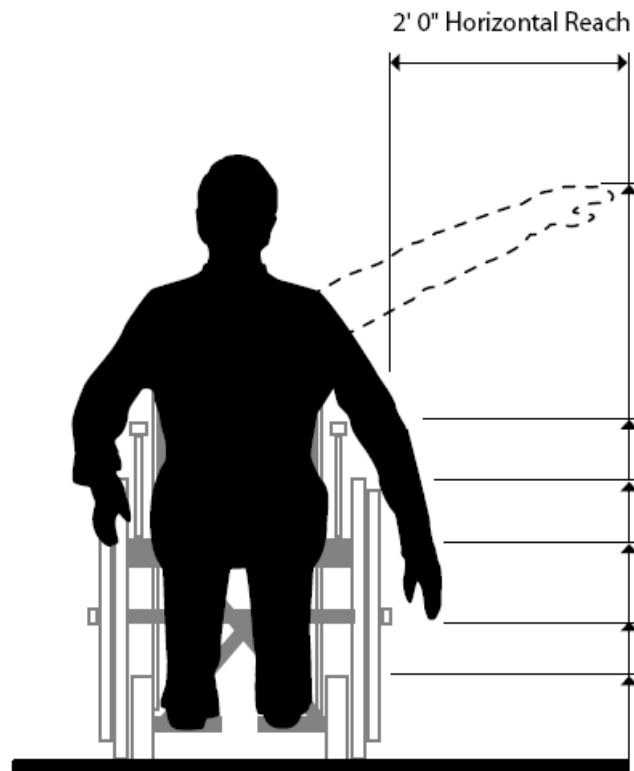

Fig. 1.2 Typical Dimensions

Typical

Actual

4'-0" Unobstructed Height Reach/
operable parts

2'-5" Chair Armrest Level/
counters, tables

2'-3" Thigh Level/tables, sinks,
lavatories, work area

1'-6" Chair Seat Level/toilets,
showers, baths

1'-3" Downward Reach/shelves, outlets

9" Foot Height/toe recesses

2' 0" Horizontal Reach (see above)

1.1.4. The measurements shown in this handbook are based on the average adult wheelchair user. However, significant variations are possible because of varying body measurements and wheelchair dimensions. **The designer should verify all measurements with the user.**

Dimensions relating to range of comfortable reach are based on an individual's capabilities while sitting upright. In most cases, a person's reach is considerably greater when he or she leans forward from the waist.

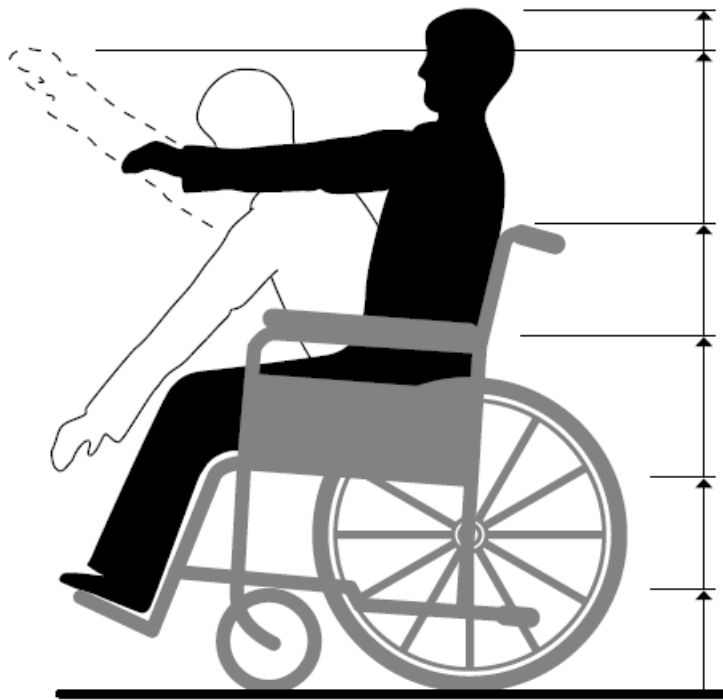

Fig. 1.3 Typical Dimensions

Typical

Actual

4'-5" Head Height/shower fixtures

4'-0" Eye Level/windows, mirrors

3'-0" Push Handle Height

2'-3" Elbow Level/counters, tables

1'-3" Knuckle Level/shelves, electric outlets

9" Foot Height/toe recesses

Site Considerations and Outdoor Design

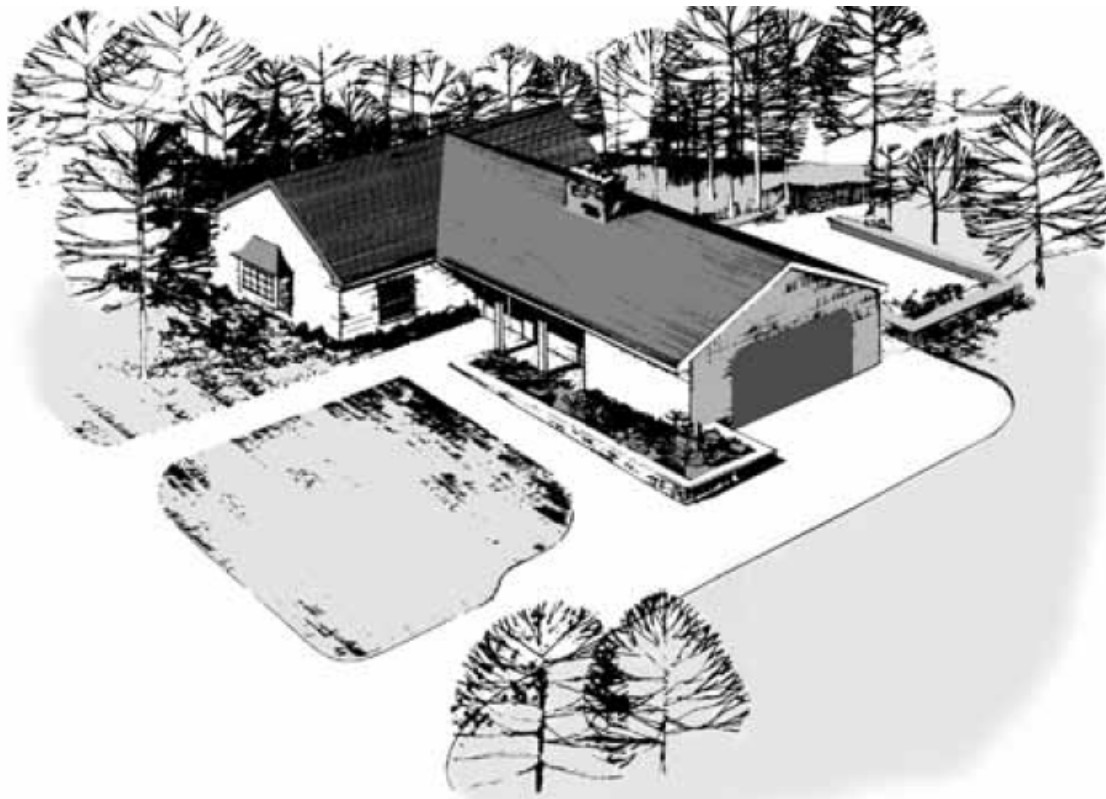

2.1. The Site

A suitable site is important to the success of a specially adapted home. Although the site need not be perfectly level, it should accommodate a single-story home without the need for excessively long (30' maximum) ramps or stairs for access to the street or driveway (Figure 2.1.).

2.1.1. A sloping site may be adapted by careful design and grading to accommodate a driveway, walkway, and residence. Parking facilities must be included in the design of a residence. The driveway and the residence must be connected by a walkway or ramp. The portion of the driveway adjoining this walkway or ramp must be level and be long and wide enough to allow the wheelchair user to maneuver around the car.

2.1.2. Outdoor spaces such as patios, decks, and gardens should be designed to accommodate wheelchair users. For example, flowers and vegetables in raised planters allow wheelchair users access to the garden. Patios and decks should be sheltered from wind and sun, and should be adequately lighted to allow their use at night. Paved, hard-surfaced walks should connect all outdoor living spaces.

NOTES:

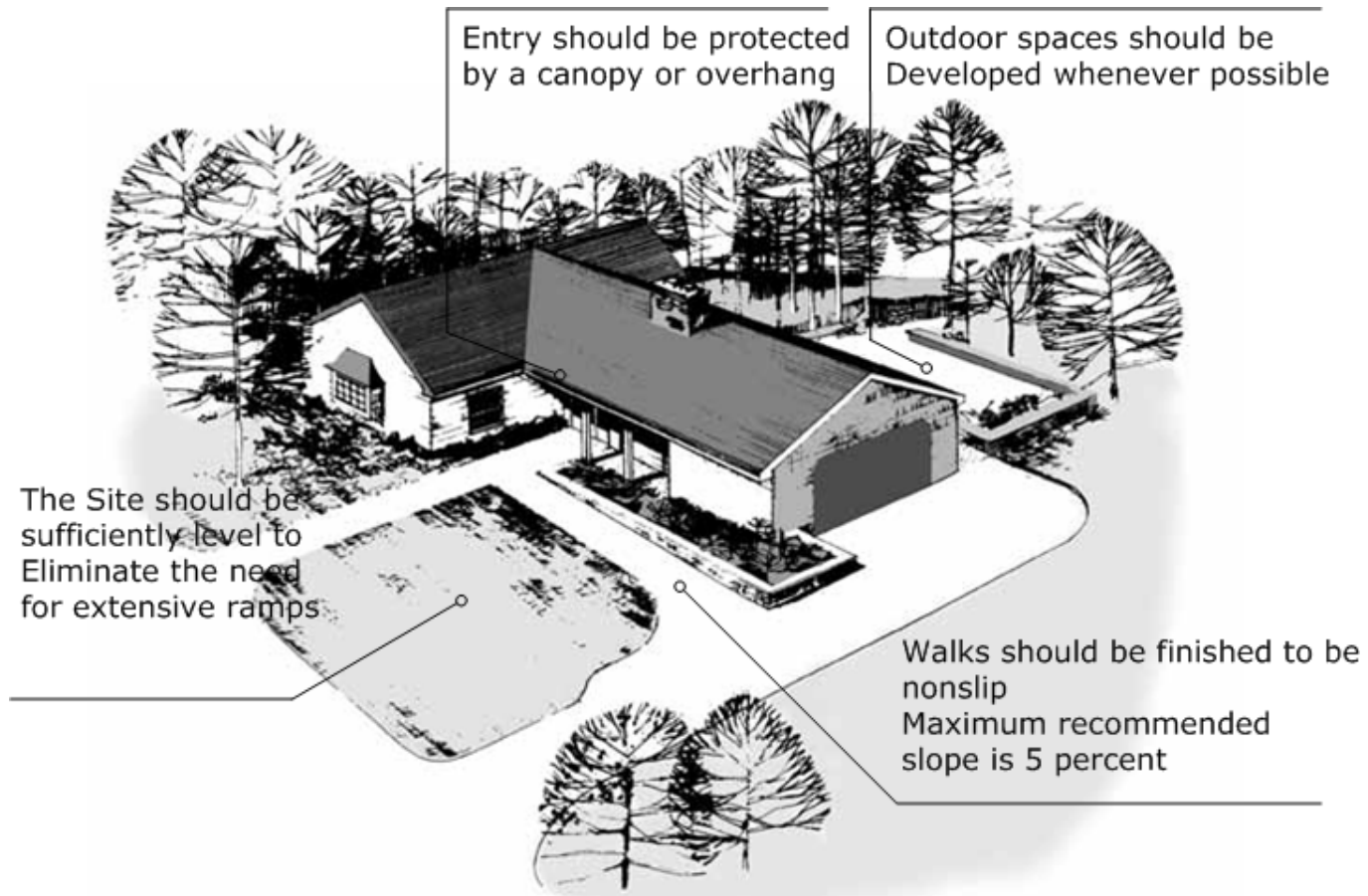

Fig. 2.1 Site Considerations

2.2. Walks and Ramps

The residence should be sited to minimize the need for extensive ramps or stairs. People who are ambulatory often prefer stairs to ramps. For the wheelchair user, however, permanent ramps, lifts, or sloped walks must be provided to accommodate changes in elevation. Although most wheelchair users can negotiate ramps or walks with a maximum slope of 8 percent, if a slope exceeds 5 percent, the individual may need to propel himself or herself by holding on to handrails on both sides. In addition, ramps with even a slight degree of slope may require handrails for safety. For walks with the same grade as the ground, handrails are not necessary unless the slope exceeds 5 percent. (See Handrails, 2.3.)

- 2.2.1. Walks and ramps must be at least 3'-6" wide (Figure 2.2). To accommodate the turning radius of a wheelchair, a width of 5'-0" is preferable.
- 2.2.2. A low curb (approximately 4" high) on one or both sides of a ramp or walk can serve as a guardrail and prevent the wheelchair user from scraping his or her knuckles on a parallel wall (Figure 2.2).
- 2.2.3. The surface of walks and ramps must be of a nonslip material, but the finish should not be so rough as to make wheelchair travel difficult or unpleasant. The number and size of expansion joints should be minimized. Permanently installed ramps may be constructed of pressure-treated lumber, concrete, or metal.

- 2.2.4. Walks or ramps with a slope between 5 percent and 8 percent should be 3'-6" wide, with handrails on both sides. This width will allow the wheelchair user to reach both handrails at the same time. The slope of ramps must not exceed 8 percent.
- 2.2.5. For long walkways and ramps with a continuous slope, a level rest platform should be provided every 30'-0". This platform should be at least 5'-0" by 5'-0". A similar platform should be provided at any point where a sloped walk or ramp changes direction. A level area 5'-0" in length should precede any sloped walk or ramp.

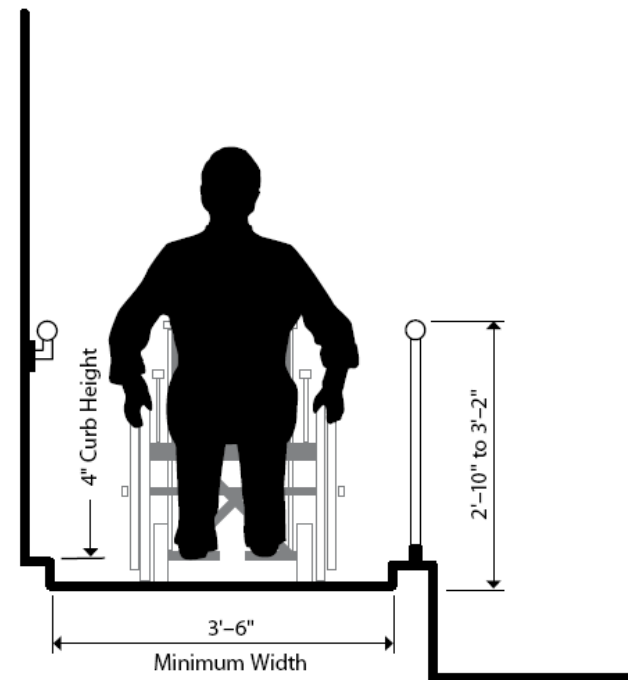

Fig. 2.2 Ramp Widths

2.2.6. Because ramps may serve as an emergency exit, the ramp/walkway must be constructed of fire-retardant material and must be nonslip or be treated to prevent slipping when wet, including, but not limited to:

- broom finish for concrete surfaces,
- built-in heating coils,
- ¼" spacing between decking boards, and
- metal grating.

2.2.7. Where ramps are exposed to inclement weather, a canopy should be provided for protection. In cold climates, built-in electric heating coils are desirable to melt snow or ice.

2.2.8. Where stairs are provided, all risers should be slanted or beveled. Open risers or risers with protrusions or overhanging nosings are unacceptable. An individual wearing leg braces can trip on stairs if he or she cannot manipulate the toe to clear the nosing.

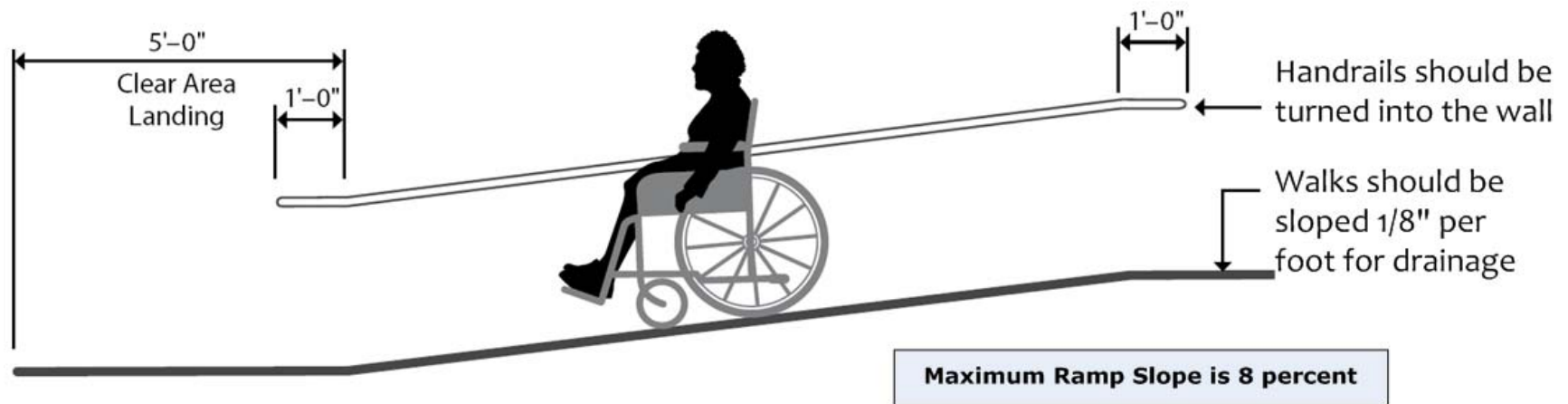

Fig. 2.3 Ramps

2.3. Handrails

Handrails serve three primary functions for the wheelchair user: (1) as a safety barrier to protect the user from a fall, (2) as an aid to balance, and (3) as a means of propulsion. All stairs, ramps, and platforms that are high enough to pose a danger from falls should have handrails. Many individuals prefer narrow stairways that allow them to use handrails on both sides. Handrails should be provided on both sides of any ramp with a slope greater than 5 percent. If the slope is less than 5 percent, a handrail may not be necessary, but the ramp/walkway must have a low curb/guard rail on both sides of the ramp.

- 2.3.1. Handrails should be installed on both sides of stairs at a height of approximately 2'–9". Handrails on ramps should be mounted at a height of between 2'–10" and 3'–2" (Figure 2.2).
- 2.3.2. Handrails should be mounted with a 1-1/2" clearance from the wall (Figure 2.5). With a larger clearance, an arm could become wedged between the wall and the handrail. To prevent scraped knuckles, the wall behind a handrail should not be rough or highly textured.
- 2.3.3. A handrail with a 1-1/2" diameter provides the user with a satisfactory grip. If an oversized handrail is used, a firm grasp can be achieved by cutting grooves in the handrail (Figure 2.4).



Fig. 2.4 Handrail Grips

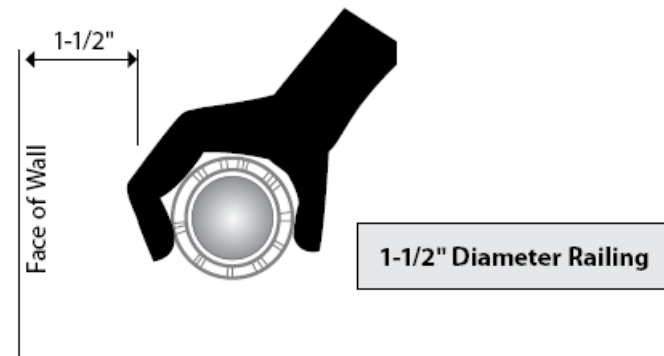

Fig. 2.5 Handrail Grips

- 2.3.4. Handrails should be smooth, continuous, and uninterrupted in the vertical or horizontal plane. Handrails should continue at least 1'-0" beyond both ends of the stair or ramp (Figure 2.6). The ends of all handrails should be turned down or turned into the parallel wall.

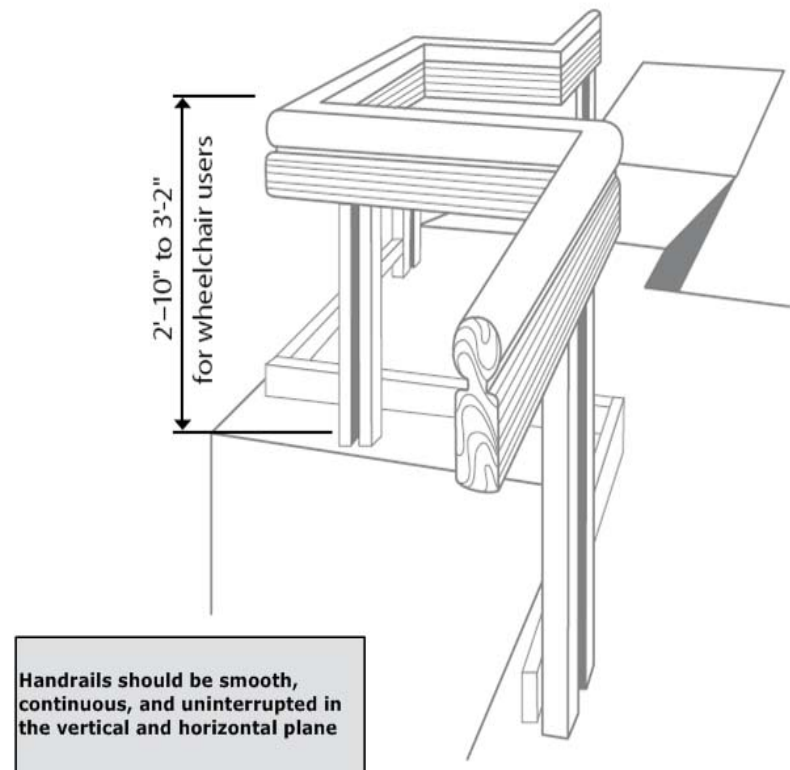

Fig. 2.6 Handrails

2.4. Entrances

A level platform must be provided at the entrance to the residence. It must be large enough to accommodate wheelchair maneuvering and should not be obstructed by doormats or drainage grates. Doors should open easily, and locks should be placed at a convenient height and be easy to use. Storm and screen doors should be avoided because they are cumbersome to operate. Doors and frames should have adequate insulation and weather stripping.

- 2.4.1. The entrance platform should be at least 5'-0" by 5'-0". The platform should include a clear area 1'-6" wide beside the door on the side opposite the hinges. (See Door Operation, Section 4.1.). The platform may be sloped 1/8" per foot to provide drainage. The entrance platform should be protected from inclement weather by a canopy or overhang. The platform surface must be of a nonslip material.
- 2.4.2. The threshold at the front door must be no higher than 1/2". Any vertical obstruction higher than 1/2" may impede movement of the small front wheels of the wheelchair. For this reason, a neoprene sweep strip should serve as either weather stripping at the doorsill for all points of ingress/egress.
- 2.4.3. Doorbells and mailboxes should be mounted at a height of 3'-0" to 3'-9".

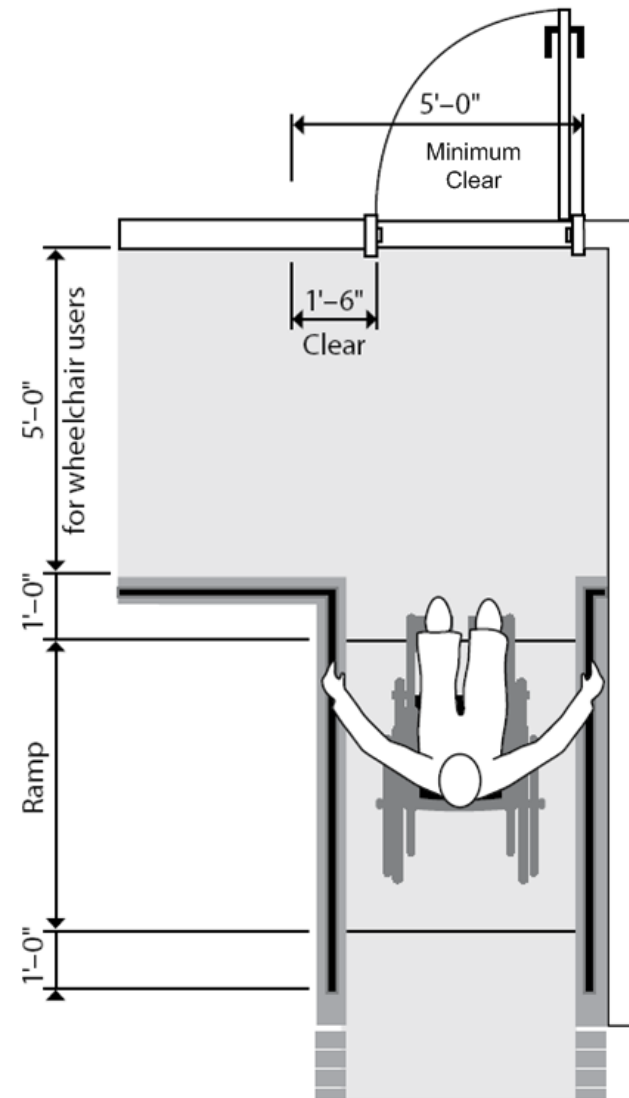

Fig. 2.7 Minimum Entrance Requirements

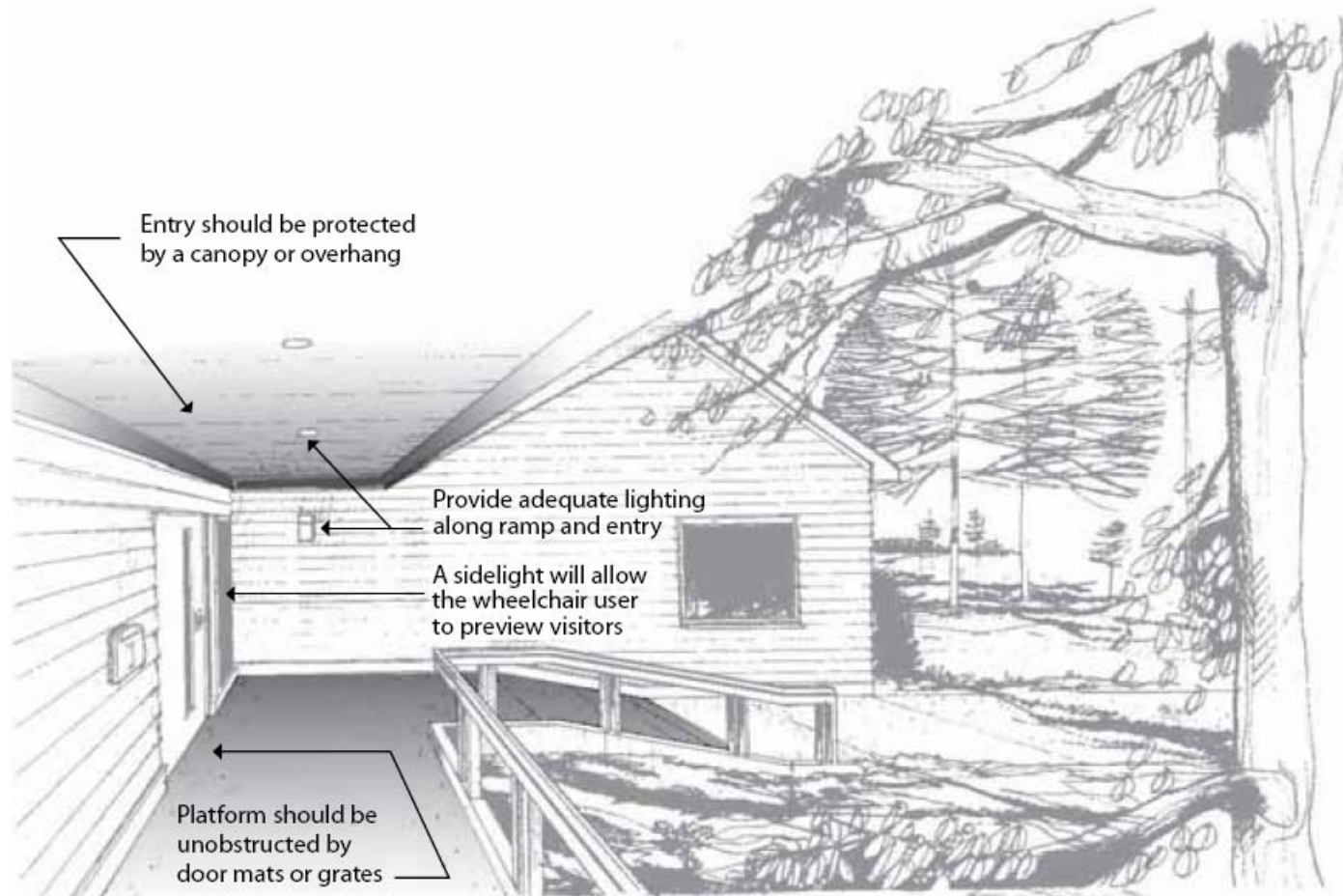

Fig. 2.8 Entrances

2.5. Garages

A garage or parking space should be included in the design of a residence. The distance between the garage or parking space and the residence should be minimized. If possible, the route should be protected against inclement weather. Switches for lights or automatic garage doors should be easily accessible to the user.

2.5.1. Parking spaces should be at least 13'-6" wide. A garage, carport, or parking space must be large enough to allow adequate maneuvering room around the car and a clear area of at least 5'-0" on at least one side of the car. This clear area will allow the wheelchair user to open the car door and maneuver the wheelchair to transfer to the car seat. A passageway 4'-0" wide should be provided in front of or behind the car. Therefore, a single-car garage or carport should be at least 14'-6" wide and at least 24'-0" long. If the user uses a van with a side lift, the width of the parking and passenger discharge area should be 18'-0".

2.5.2. Whenever possible, automatic garage doors should be installed.

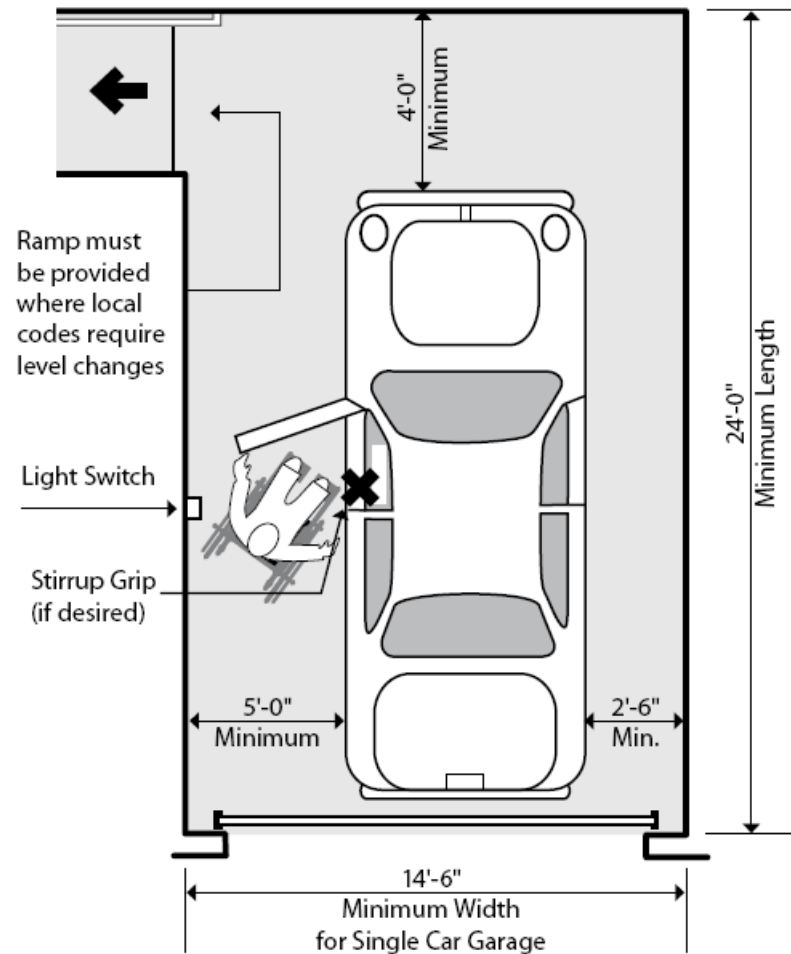

Fig. 2.9 Garage or Carport

- 2.5.3. Light switches in garages must be properly located for convenient access. If possible, an automatic on/off switch should be accessible from within the car as well as one adjacent to the passenger discharge area. Ideally, a second switch should be located in the house. A garage light that operates in conjunction with automatic garage doors should be used whenever possible.
- 2.5.4. A suspended stirrup grip or hoist facilitates transfers to and from the car.

- 2.5.5. If the garage is detached from the residence, a covered passageway with adequate overhang for protection against inclement weather must be provided. If the local building code requires a change in elevation between the residence and the garage, a ramp must be provided. (See Walks and Ramps, Section 2.2.)

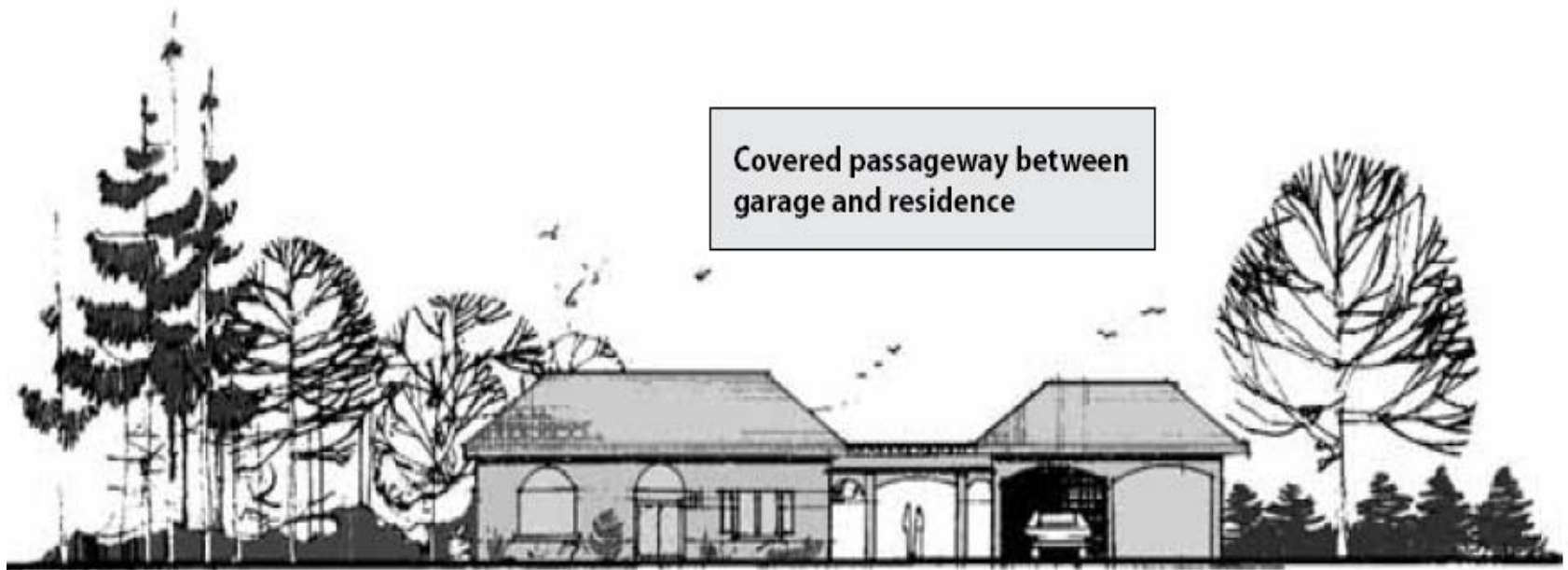
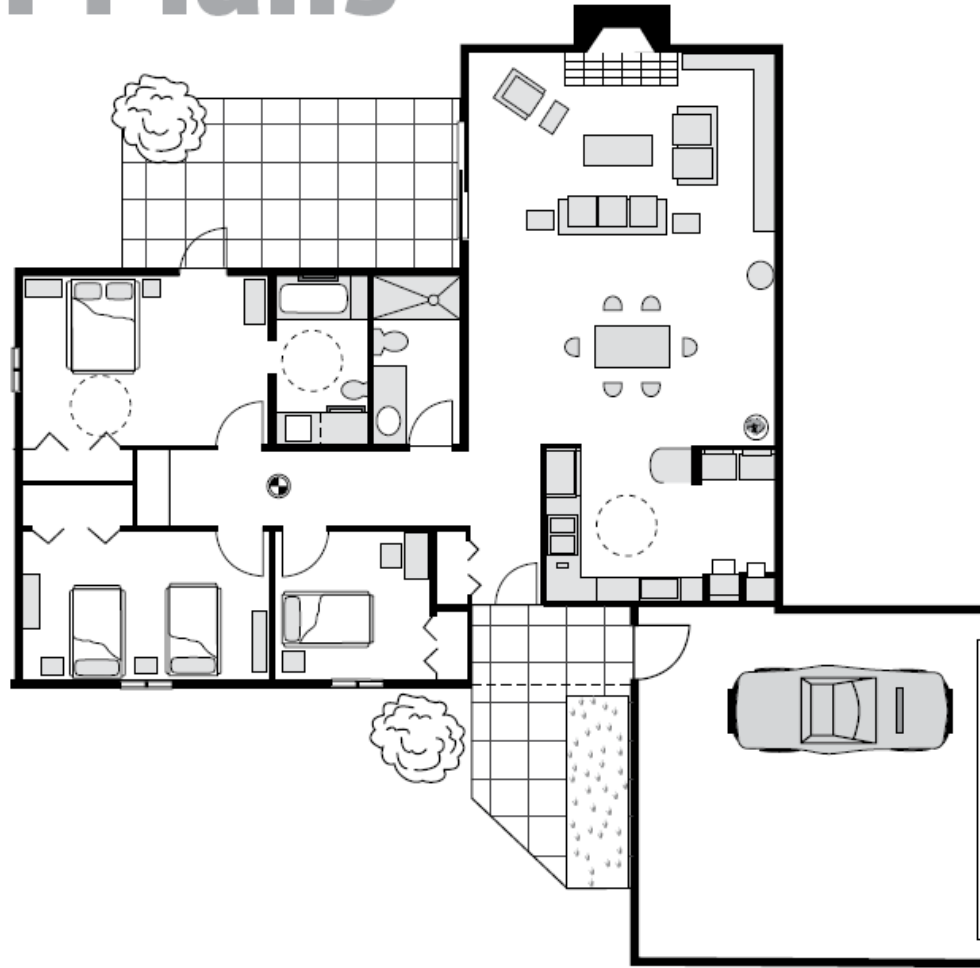

Fig. 2.10 Detached Garage

Floor Plans



3.1. General Considerations



Many types of specially adapted housing are possible. The home may be a detached residence, a townhouse, or a condominium, and it may be custom built new construction or a modification of an existing residence. Each home needs a different degree of

specialized design. Most important, each home should accommodate the needs and preferences of the individual user.

The floor plans illustrated in this section are schematic arrangements of typical single-family homes. The plans are presented only to show areas that usually require design attention and illustrate a possible solution. The following features should be considered for most adapted housing:

- 3.1.1. Single-story designs are recommended for specially adapted homes. For the wheelchair user, all essential facilities should be on one level, if practicable. Where a change in levels between rooms cannot be avoided, ramps or another means of access must be provided. (See Walks and Ramps, Section 2.2.). Rooms should be large enough to allow a wheelchair user to maneuver, and unnecessary doors and partitions should be avoided to allow maximum freedom of movement.
- 3.1.2. Interior finishes should be carefully selected for ease of cleaning and maintenance. Special consideration should be given to floor finishes. For example, bathroom and shower floors must be of a nonslip material. Low-pile, high-density carpet may be installed in appropriate locations, such as living rooms and bedrooms. In addition to its aesthetic qualities, carpet greatly reduces sound

transmission and serves to cushion falls. Loose weave or shag rugs, however, make travel difficult for wheelchair users and for those who need assistance to walk. Carpet pads, if any, should be thin and firm. All carpeting must be well-fitted and properly secured to the floor.

- 3.1.3. Because many individuals with disabilities are especially vulnerable to cold and drafts, the residence should be well insulated, and all doors and windows should be made draft-free. Zone-controlled heating may be considered to allow a user independent temperature control for the master bedroom and bath. A radiant heat lamp can provide extra heat in the bathroom.
- 3.1.4. Emergency generators should be provided to control indoor climate for persons whose disability prevents them from regulating body temperature, particularly persons with spinal cord injury or disorder(s), and burn survivors. Extreme heat or cold, even for short periods of time, can cause dangerous symptoms.

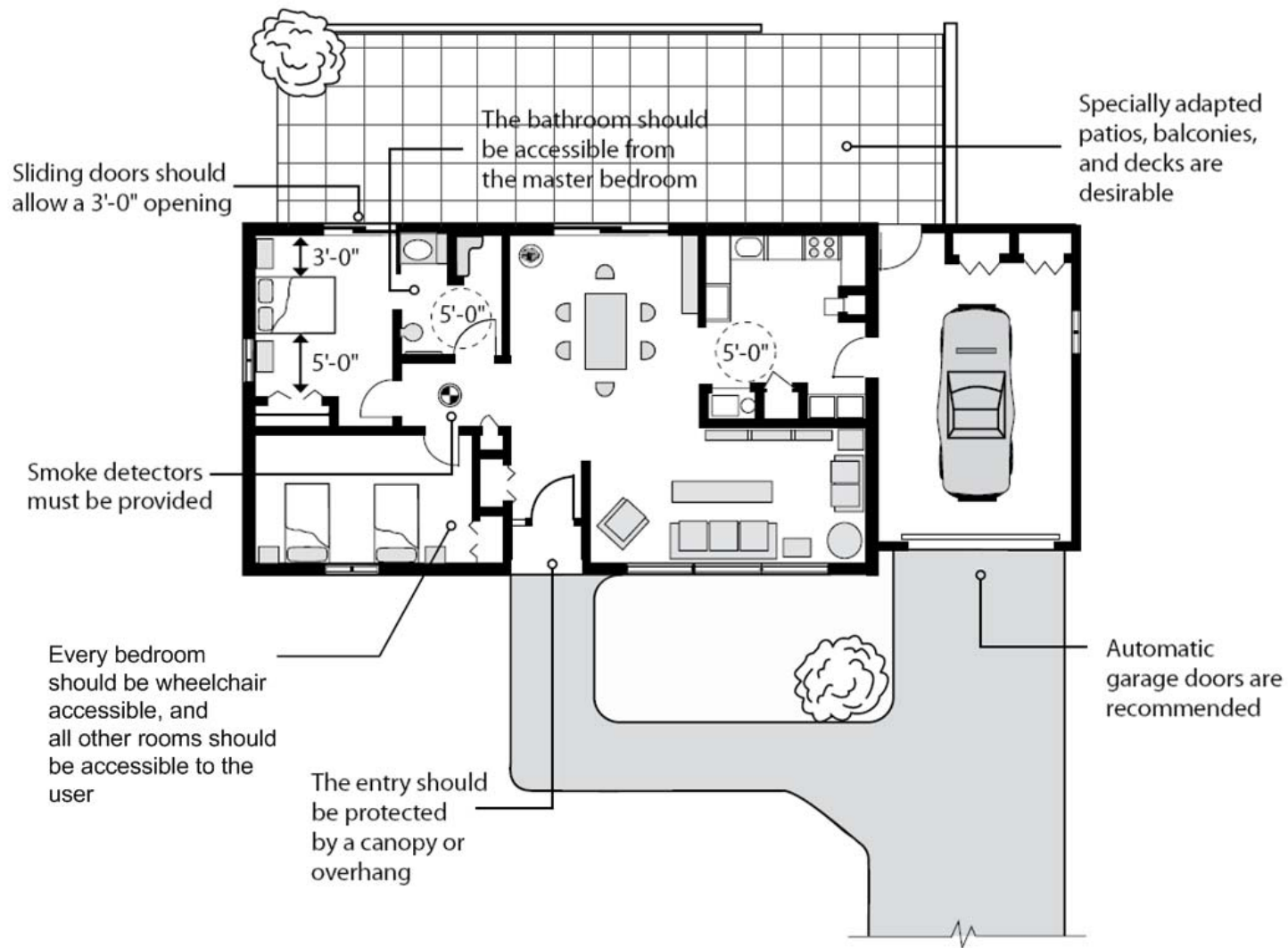

Fig. 3.1 Typical Plan

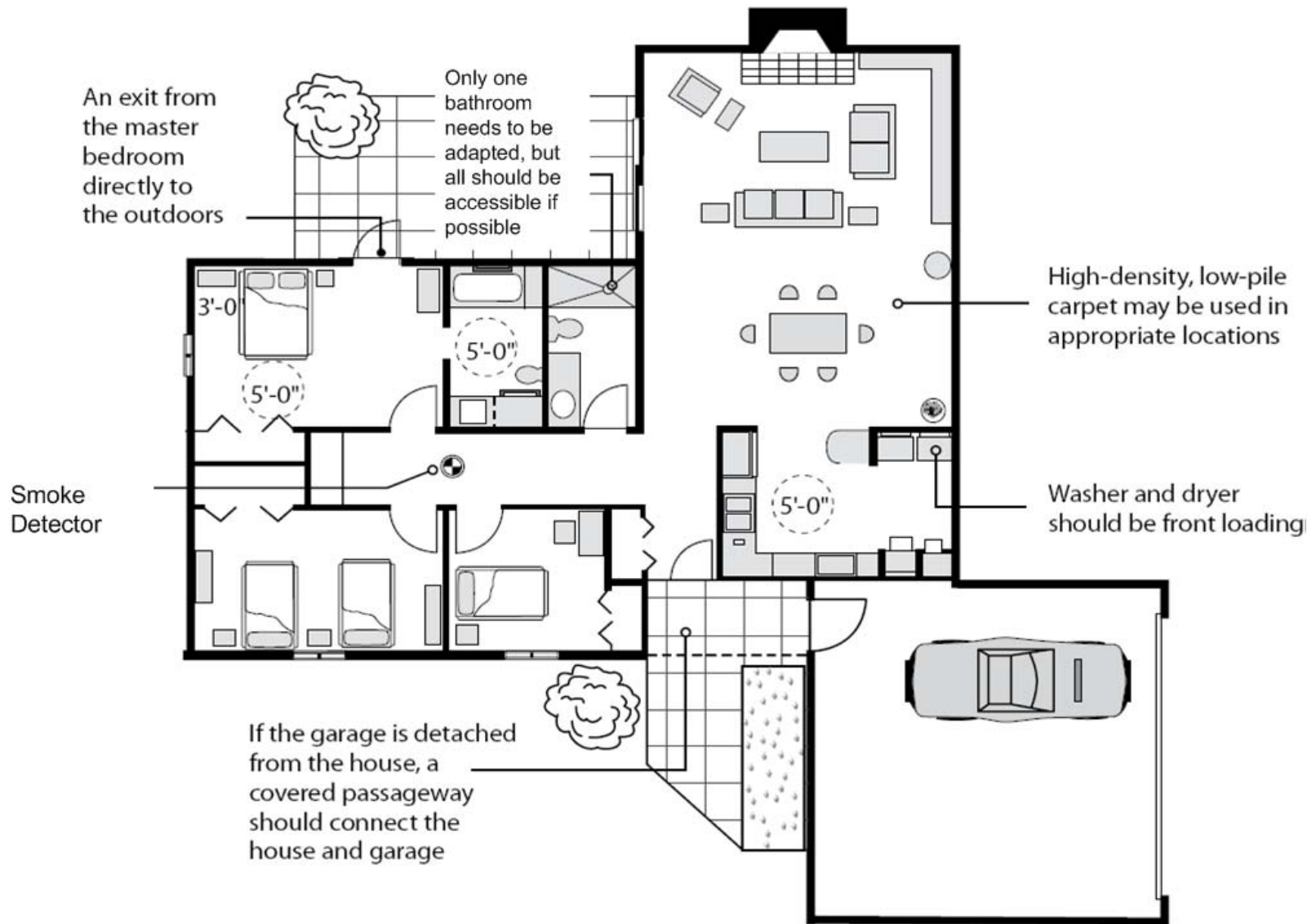
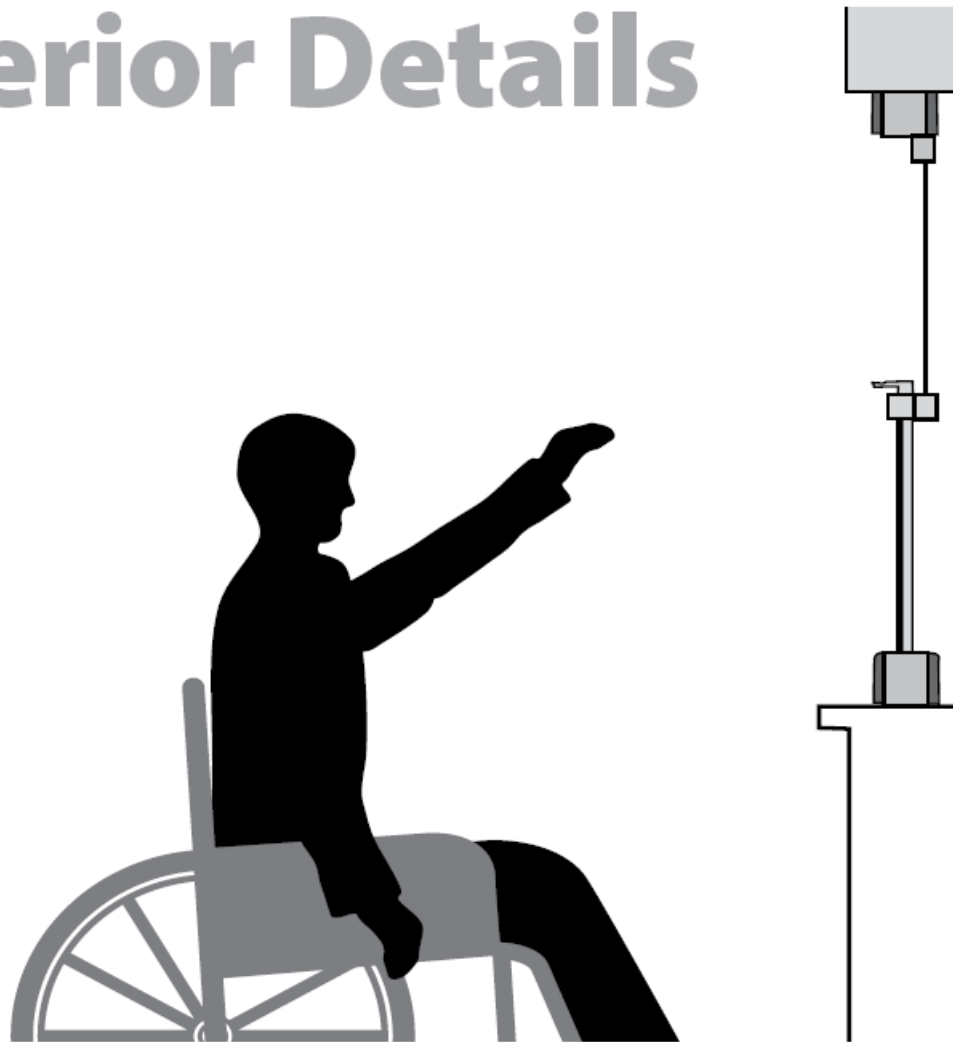

Fig. 3.2 Typical Plan

Interior Details



4.1. Door Operation

Designers must pay special attention to the location of doors and the direction of door swings. Doors should be arranged to permit easy approach by the wheelchair user and minimize maneuvering needed to open and close doors. Unnecessary doors, doors lined up in a series, and doors next to each other that open in opposite directions should be avoided.

- 4.1.1. The width of all doors and openings should be at least 3'-0". An opening of 2'-8" is acceptable only in existing homes when 3'-0" openings are not possible (Figure 4.1).
- 4.1.2. All doors should have a clear area at least 1'-6" wide adjacent to the side of the door opposite the hinges. The clear area must be provided on both sides of the door. This area allows the wheelchair user to back up to open the door (Figure 4.2).
- 4.1.3. A pull handle on the trailing side of the door enables the user to pull the door closed after passing through.
- 4.1.4. Doors to bathrooms and other confined spaces should swing outward. Doors that swing inward can be a hazard if the wheelchair user falls and blocks the door. Alternatives are sliding doors and breakaway hardware.

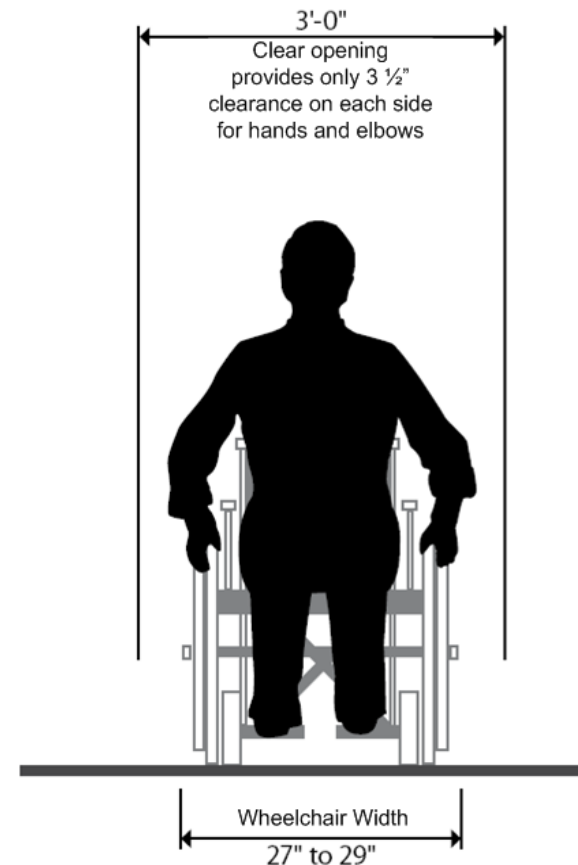

Special attachments to the wheelchair may require increased width

Fig. 4.1 Door Width

1

A clear area at least 1'-6" wide opposite door hinges is necessary for positioning the wheelchair to open the door.

This 1'-6" clear area should be provided on the inside and outside of the door.

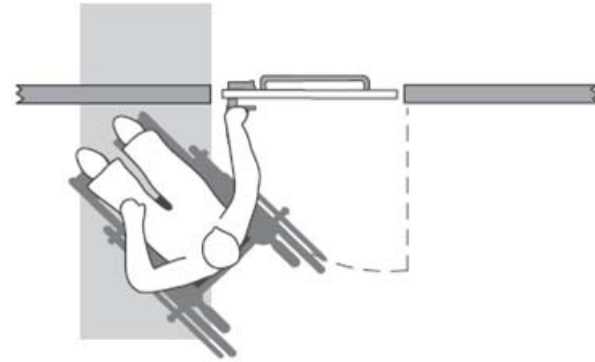

2

The door should open easily with a single motion.

All doorways must be situated to allow the doors to swing open at least 90°.

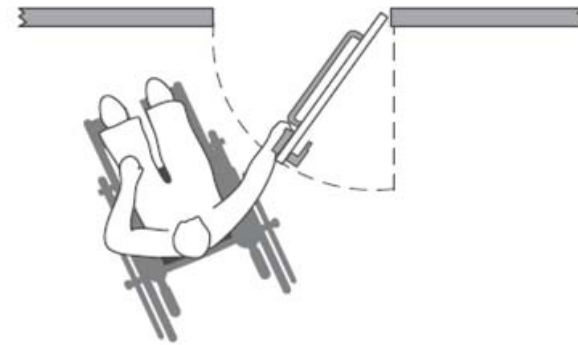

3

Doorknobs and hardware should be of a size and shape to permit a good grip.

A pull bar on the trailing side of the door helps the user pull the door closed after passing through.

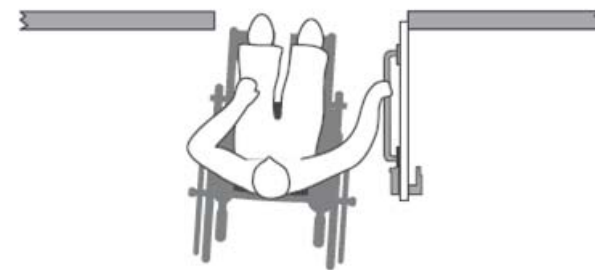

Fig. 4.2 Sequence of Door Operation

4.2. Doors

All doors and door hardware should be carefully selected. The size and weight of the door and its hardware should allow for easy operation. Thresholds, divider strips, and sliding door tracks should be avoided; but if they are used, they should be recessed. When doors are used in pairs, each leaf must comply with all requirements for a single door. Bifolding or accordion doors are easy to operate and may be used at appropriate locations. Sliding doors are often practical for exterior and interior use.

- 4.2.1. All doors must be designed so that they can be opened in a single motion. For example, locks requiring simultaneous use of both hands should be avoided.
- 4.2.2. All doors should be easy to open and close. A maximum resistive force of 5 pounds is recommended for interior doors. (If a door is too heavy or difficult to operate, the wheelchair user must set the wheelchair brake to prevent the wheelchair from rolling during the door operation.)
- 4.2.3. Door closers are not normally recommended. If closers are installed, a time delay of at least 4 to 6 seconds is recommended.

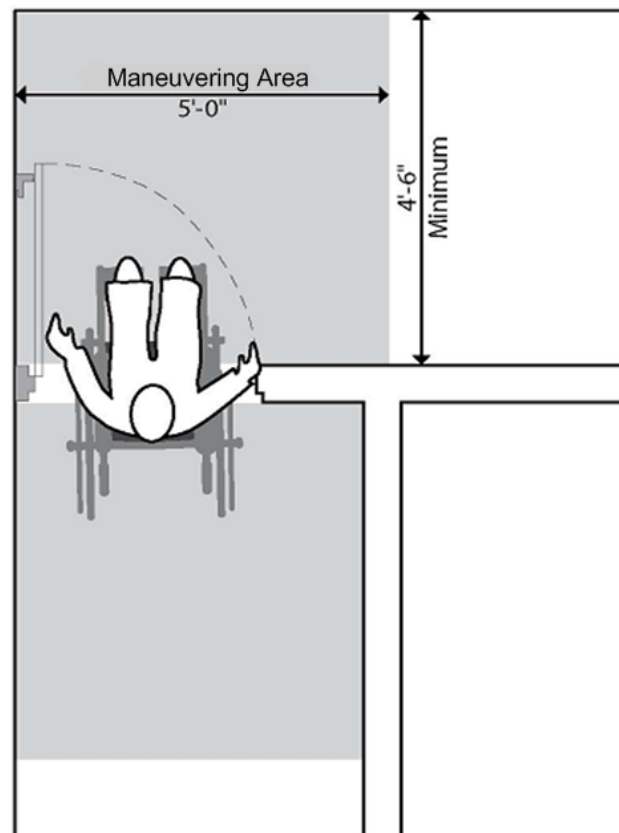

Fig. 4.3 Maneuvering Area

- 4.2.4. Door latch handles must be easy to grasp. Lever-type latch handles with the end of the handle turned into the door are recommended. (See Figure 4.4).

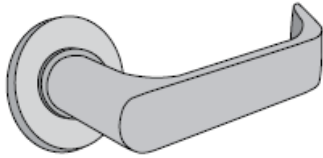

Fig. 4.4 Latch Handle

- 4.2.5. A maneuvering space at least 4'-6" in length should be provided on both sides of all doors.
- 4.2.6. Vertical or horizontal pull handles on the trailing side of the door should be at a height of 3'-0" to 3'-3".
- 4.2.7. Kickplates on one or both sides protect doors from damage.

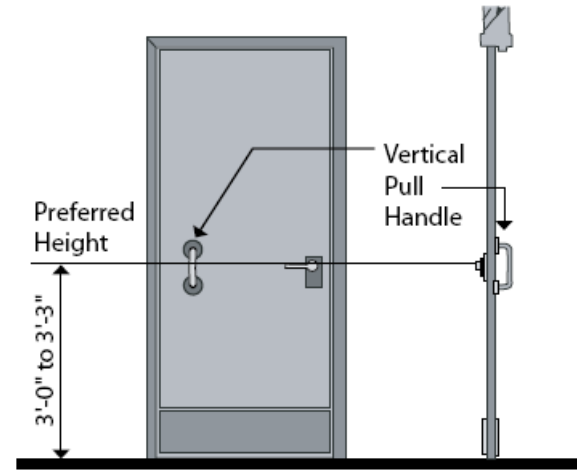

Fig. 4.5 Pull Handles

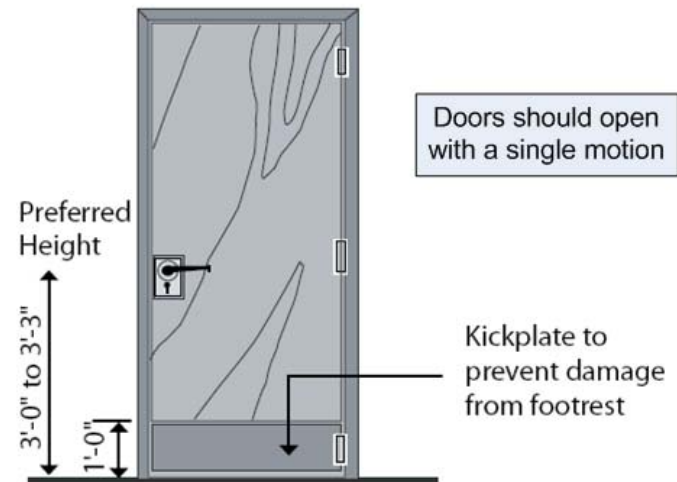

Fig. 4.6 Kickplates

4.3 Windows

Windows should be located to take maximum advantage of available light and scenery. They should be easy to open and close from a seated position. Many individuals find casement or hopper-type windows the easiest to operate. Pivoting windows offer ease of maintenance because the exterior may be cleaned from inside.

- 4.3.1. Windows intended for viewing should have a maximum sill height of 2'-9".
- 4.3.2. Window controls should be accessible and easy to operate. Window location may require the installation of special controls, such as extension bars and remote control gears. Controls should be no higher than 4'-6".
- 4.3.3. Double glazing and weatherstripping are recommended to minimize drafts and temperature variations.
- 4.3.4. Controls for curtains and blinds should be accessible to the wheelchair user.

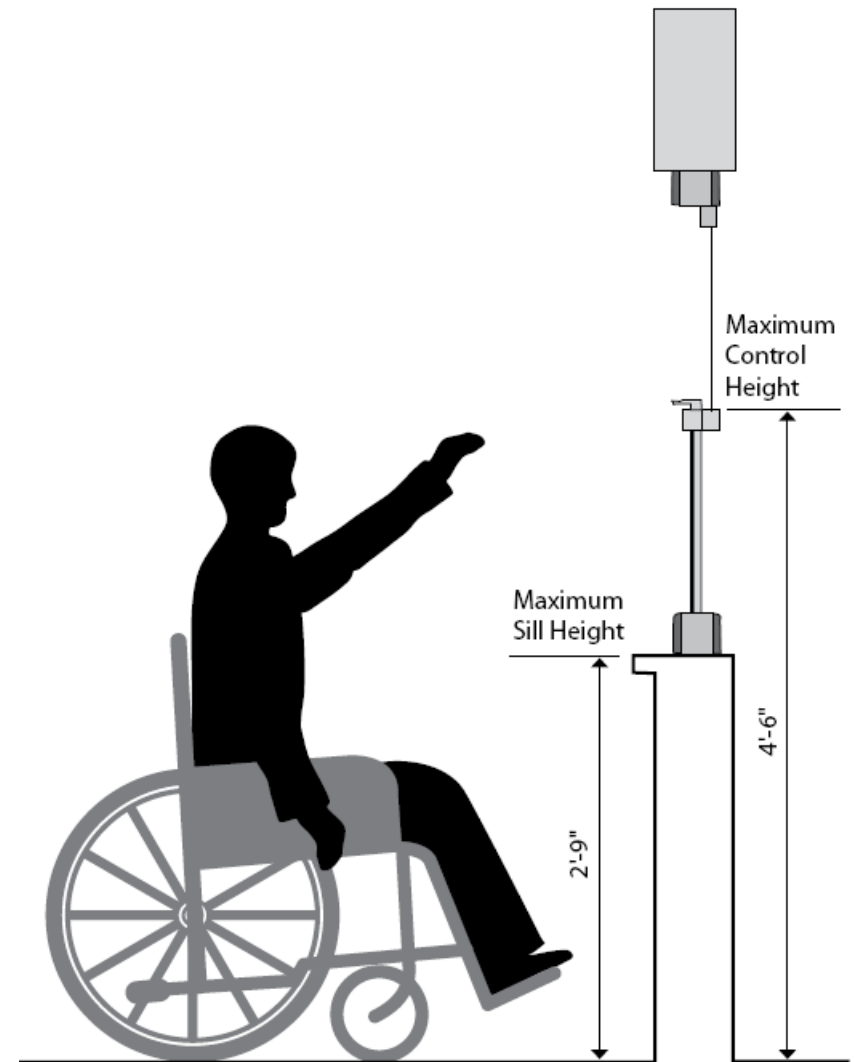

Fig. 4.7 Windows

4.4. Wall Switches and Electrical Outlets

The location and organization of electrical switches are important to good design. Inaccessible switches and large groups of confusing switches often cause frustration. This frustration can be avoided by establishing a consistent pattern of switch locations throughout the house.

- 4.4.1. All switches should operate with a single action. Individuals may prefer a rocker or a push button switch instead of a toggle switch. Wall switches and electrical outlets must be a minimum of 18 inches and a maximum of 48 inches from the floor and must have unobstructed access from the wheelchair.
- 4.4.2. Switches and thermostats should be no higher than 4'-0". The preferred height is 3'-0" to 3'-9".
- 4.4.3. To help the user locate a switch, switches near doors should be at the same height as the door handles. In certain places, such as entrance foyers, light switches with locator lights are a convenience.

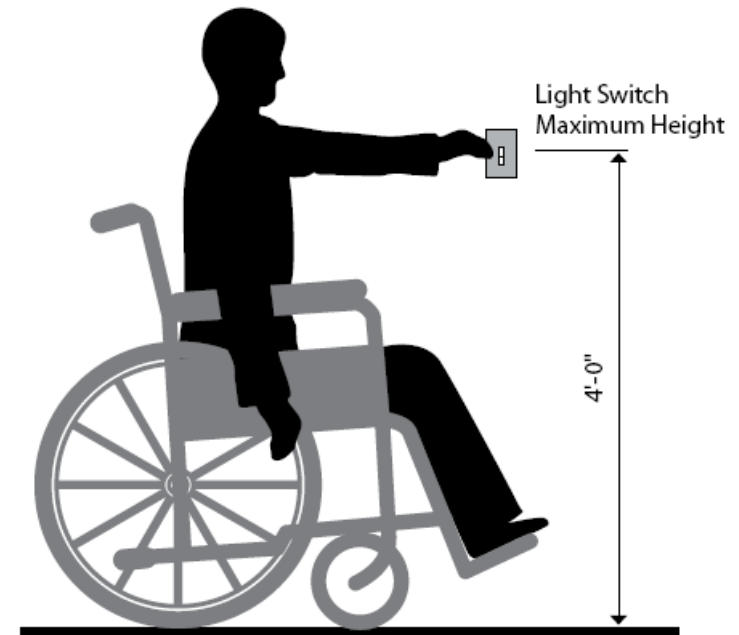

Fig. 4.8 Wall Switches

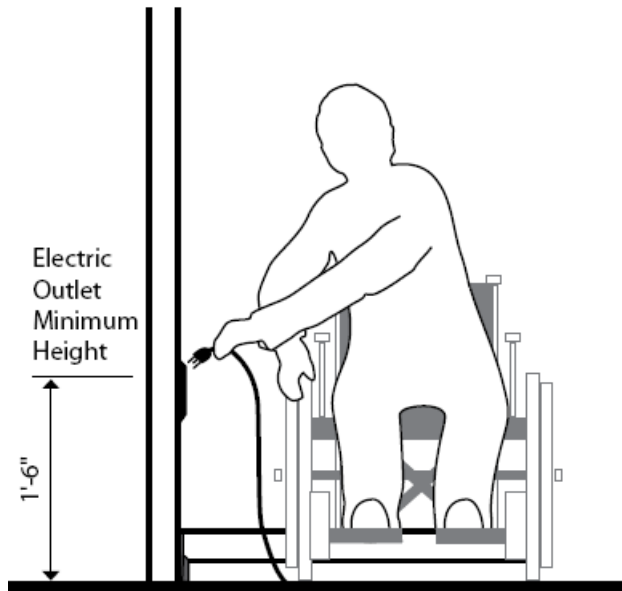

Fig. 4.9 Electrical Outlets

- 4.4.4. Any electrical outlets near water (bathroom vanity, tub, shower, kitchen sink, or laundry tub) must be of a GFI type.
- 4.4.5. Electrical outlets must be located no higher than 4'-0" and no lower than 1'-6".

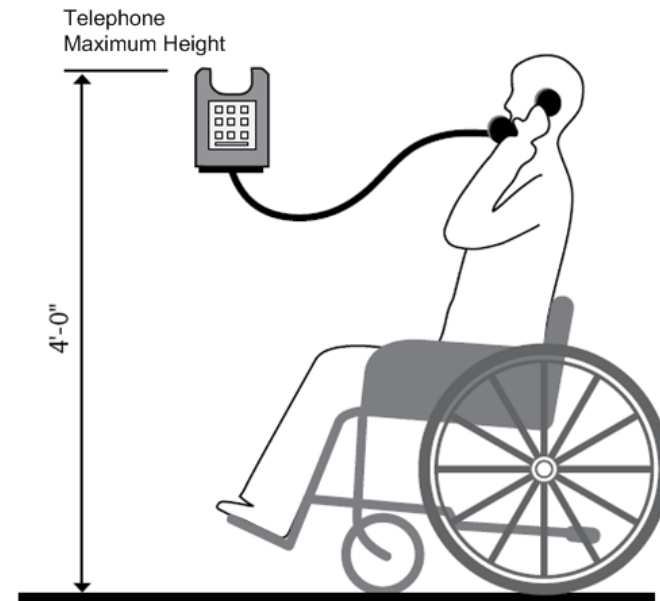

Fig. 4.10 Telephones

- 4.4.6. Wall-mounted telephones should be no higher than 4'-0". The preferred height is 2'-9" to 3'-3". Telephones should not be mounted above counters. Ease of access is restricted from a wheelchair.
- 4.4.7. Telephone extensions or plug-in jack outlets should be provided at critical locations, such as bedrooms and bathrooms.

4.5. Corridors

For ease of movement, the home should be organized to eliminate the need for long corridors and confining spaces. If corridors are present, they should be free from obstructions. Because the wheelchair user becomes familiar with maneuvering within his or her home, wall protection is not usually necessary. However, wheelchair hand rims and footrests may damage wall finishes in narrow corridors.

- 4.5.1. The minimum corridor width is 4'-0". The preferred width is 5'-0". A corridor width of 42" is acceptable only in existing homes.
- 4.5.2. Unless opening into an individual's bedroom or bathroom, doors opening into corridors should swing into rooms to allow unobstructed movement through the corridors.
- 4.5.3. A nonscuff strip protects wall finishes in confined spaces and areas of heavy traffic. The strip should be mounted at a height of 1'-0".

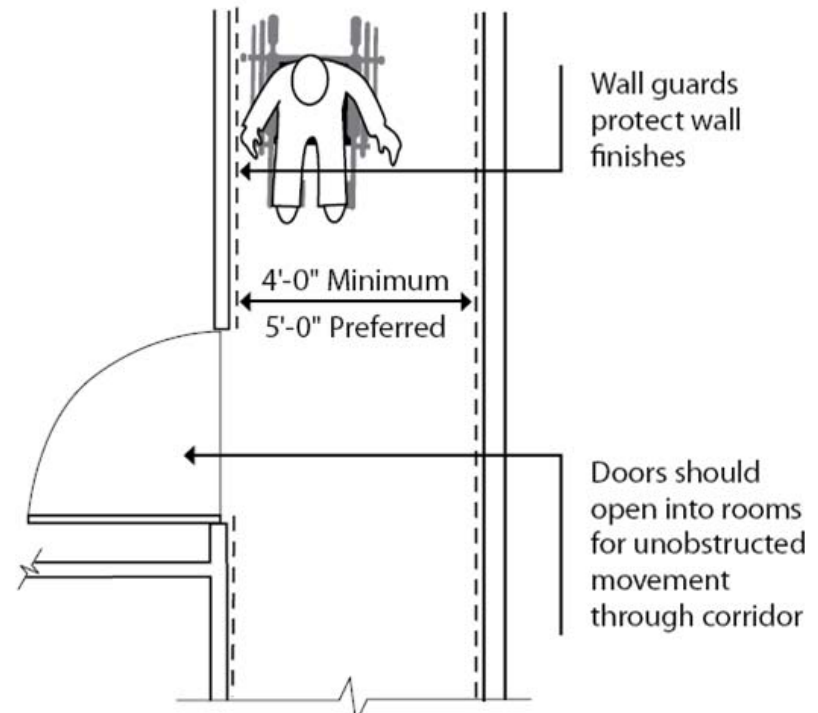

Fig. 4.11 Corridors

4.6. Closets

The home should include adequate closet and storage space in convenient and accessible locations. Room for wheelchair maneuvering should be provided in front of all closets. Bifolding doors, accordion doors, and sliding doors are all acceptable for use as closet doors. In the master bedroom, a combination dressing room and closet offers an excellent alternative to traditional closet arrangements.

- 4.6.1. A clothes hanger rod between 3'-6" and 4'-0" high is appropriate for most clothing and within easy reach of the wheelchair user. The maximum rod height is 4'-6". Adjustable hanger rods are also available.
- 4.6.2. Shelves should be mounted no higher than 4'-0" and should be no deeper than 1'-4".
- 4.6.3. If sliding doors are used, floor-mounted tracks or guides must not pose an obstruction to the wheelchair user. Transition ramps are commercially available to make tracks accessible.

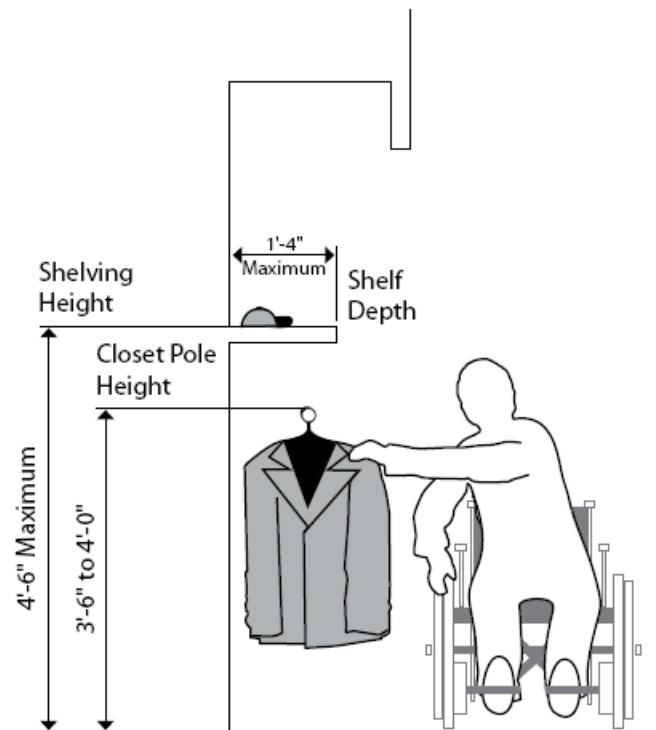

Fig 4.12 Closets

4.7. Stairs

Ideally, homes should be single-level. However, modification of existing multi-story homes may be necessary. Wheelchair lifts or inclined elevators may be adapted to existing stairs.

4.7.1. Stair lifts offer an alternative to climbing stairs. Such lifts are easily installed and require minimum modification to existing stairs. However, stair lifts are seldom suitable for wheelchair users.

4.7.2. Inclined platform lifts suitable for installation on stairs are commercially available. When not in operation, the lift is stored at the bottom of the stairs to permit conventional use of the stairway.

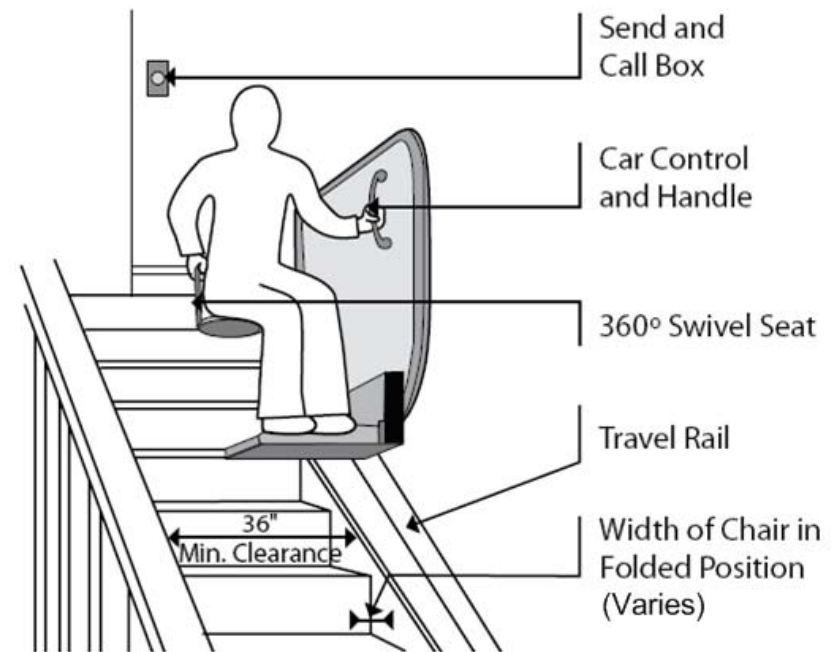

Fig. 4.13 Stair Lift

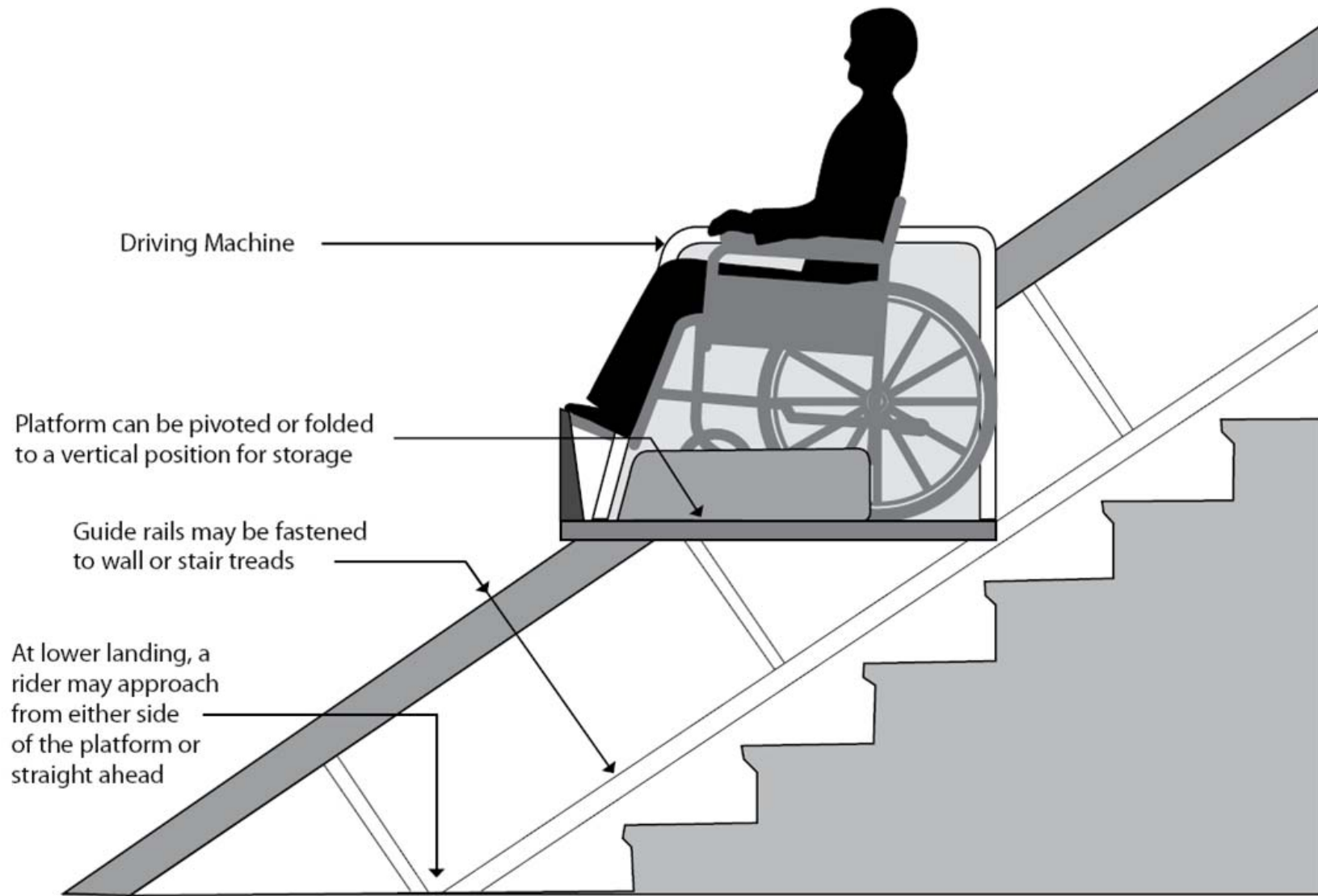
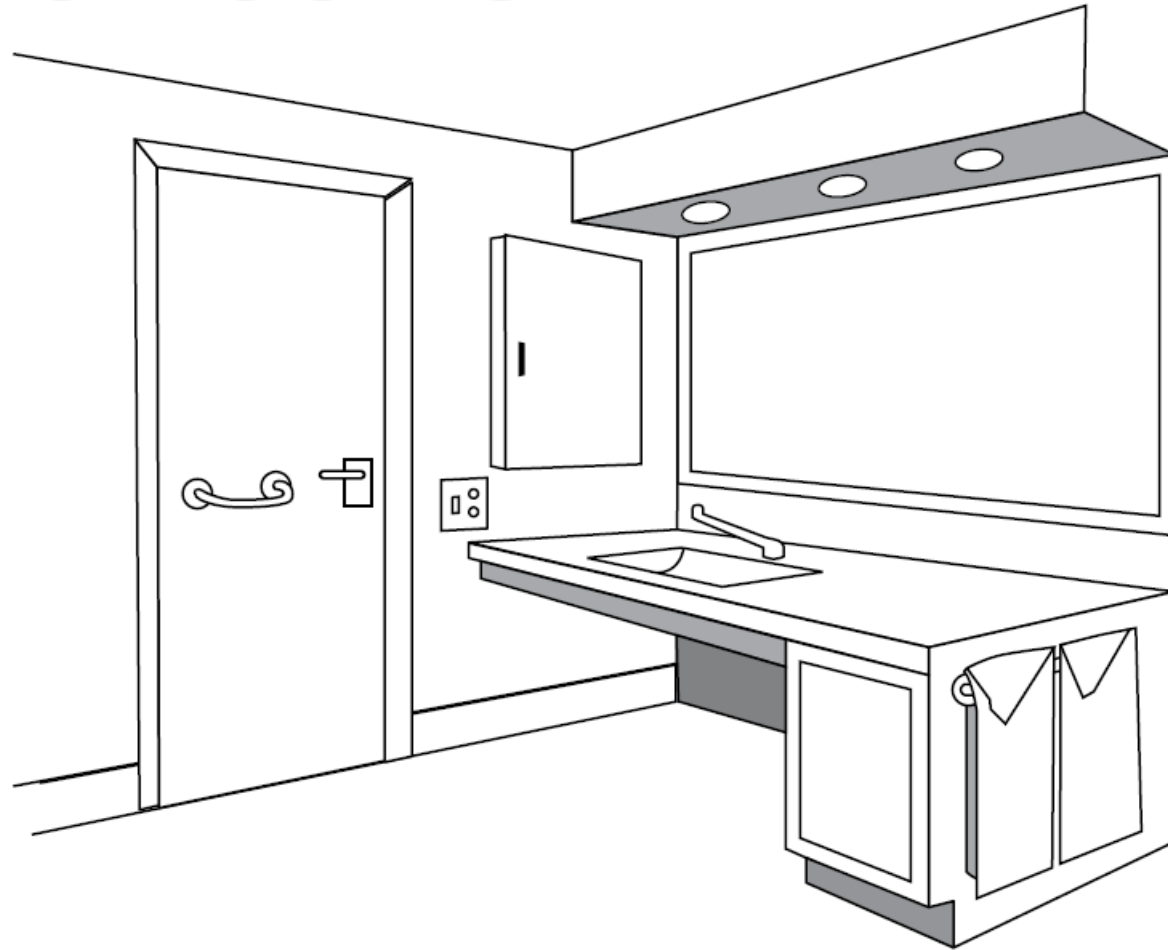

Fig. 4.14 Inclined Platform Lift

Bathrooms



5.1. Bathroom Design

The bathroom is the most difficult room to design in a specially adapted home. The bathroom is a relatively confined space, yet extensive maneuvering is usually necessary. The bathroom's design must allow the wheelchair user to transfer from the wheelchair to various bathroom fixtures, such as a toilet, bathtub, and shower.

To perform this transfer, the user must first be able to maneuver the wheelchair to a convenient location. With the aid of grab bars, the user then transfers from the wheelchair to the fixture. This transfer is made easier if the fixture is approximately the same height as the wheelchair seat. (Wheelchair seats are typically 1'–8" in height.) Although stirrup grips or suspended hoists aid in transfer, grab bars should be installed to provide support when the individual is out of the wheelchair. All accessories, such as soap dishes, toilet paper holders, towel rods, and electrical outlets, should be convenient to the appropriate fixture.

Every wheelchair user has a preferred transfer technique, which includes a direction of transfer, either from the left or from the right. When possible, bathtubs, toilets, and shower seats should be located to accommodate that preference.

5.1.1. Bathrooms should have a clear area for maneuvering. To accommodate maneuvering, this area should have a diameter of at least 5'–0", which is the turning radius of the average wheelchair. However, the area should be adjusted, as necessary.

- 5.1.2. A clear area 4'–0" in length should be in front of all bathroom fixtures.
- 5.1.3. If the lavatory and the toilet are located on the same wall, there must be space between the fixtures. For a wheelchair user to transfer using the parallel sequence (Figure 5.6), at least 3'–6" should be allowed between the centerline of the toilet and the edge of the lavatory (Figure 5.1).
 - 5.1.4. If a lavatory is located near a corner, the centerline of the basin should be at least 1'–6" from the side wall (Figure 5.1). To provide enough room for grab bars, toilets should be located so that the center line of the fixture is 1'–6" from the adjacent wall. If the side of the toilet is not adjacent to a wall, the centerline of the grab bar should be 1'–4" from the center line of the toilet.
 - 5.1.5. All shelving, towel rods, and electrical outlets should be at a convenient height and should be within easy reach. The user should not have to reach across a fixture to access shelving, towels, or outlets.

- 5.1.6. Because of space limitations and safety considerations, bathroom doors should swing out. If a door swings into the bathroom, breakaway hardware should be used (See Door Operation, Paragraph 4.14.).
- 5.1.7. Bathroom floor finish must be a nonslip material.
- 5.1.8. If landlines are used, telephone jacks or extensions should be considered for the bathroom for safety and convenience (See Telephone Extensions, Paragraph 4.47, Wall Switches and Electrical Outlets, Section 4.4).

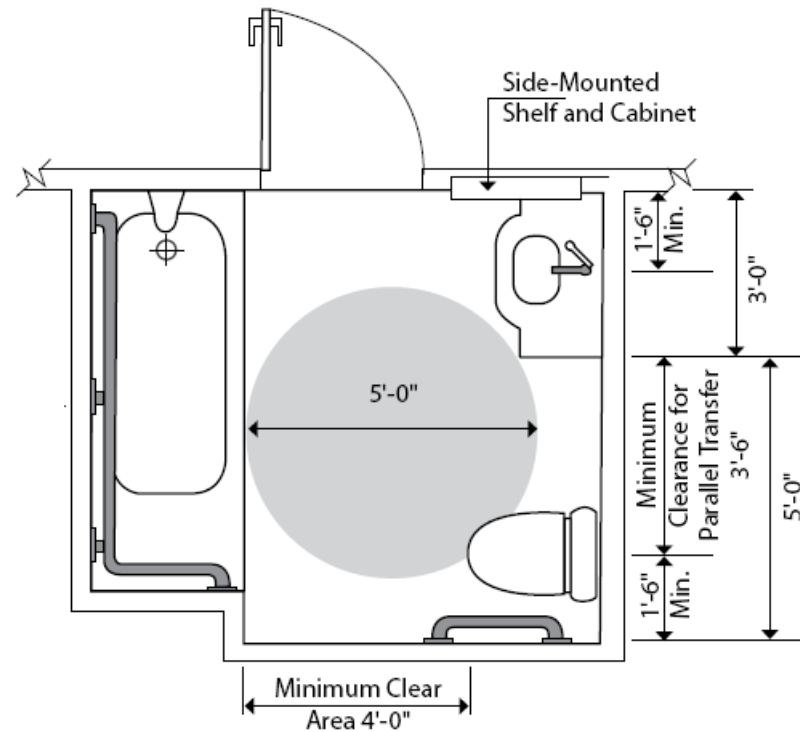

Fig. 5.1 Typical Bathroom Arrangement

5.2. Bathroom Fixtures

All bathroom fixtures must be carefully selected and located to suit the user's needs. Special attention should be paid to lavatory basins, faucets, and accessories.

- 5.2.1. Toilets should generally have a seat height of 1'-8". For some individuals, slight adjustments in height may be required to facilitate transfer to and from the wheelchair. A bidet or a combination toilet/bidet may be useful, especially for users who have limited or no use of their hands.
- 5.2.2. A horizontal grab bar at a height of 2'-9" should be installed adjacent to the toilet to help the user transfer to and from the wheelchair. If the user prefers the front transfer sequence (Figures 5.5 and 5.6), grab bars should be installed on both sides.
- 5.2.3. Grab bars should be 1½" in diameter and be adequately secured to support the user's weight. Typical grab bar locations are illustrated in Figures 5.6 and 5.7. However, individual needs must be considered. As a general rule, horizontal grab bars are used for pushing up and vertical grab bars are used for pulling up.
- 5.2.4. Lavatories should be mounted no higher than 2'-10". Lavatory basins should have as shallow a profile as possible to maximize knee space below. Lavatories should extend approximately 2'-3" from the wall.

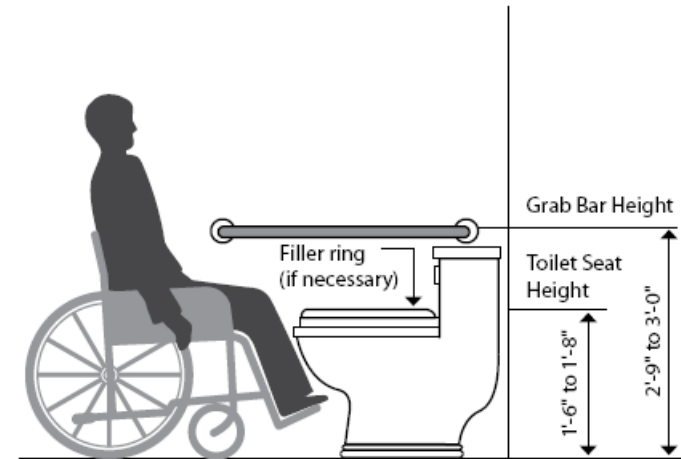

Fig. 5.2 Floor-Mounted Water Closet

- 5.2.5. All exposed water supply and drain lines must be insulated to prevent burns and scrapes.
- 5.2.6. The water spigot should be at least 4" clear of any rear obstruction and at least 4" above the lavatory rim to allow for easy rinsing. Lever-type temperature controls are recommended and preferred for ease of use.
- 5.2.7. To maximize knee space below the lavatory, p-traps in drain lines should be offset horizontally, or traps may be located in the wall and be reached through an access panel.
- 5.2.8. Shelving and medicine cabinets should be within easy reach (Figures 5.1 and 5.4).
- 5.2.9. Mirrors should be tilted or lowered to accommodate an individual in a seated position. The bottom edge of a flat mirror should be no higher than 3'-0".

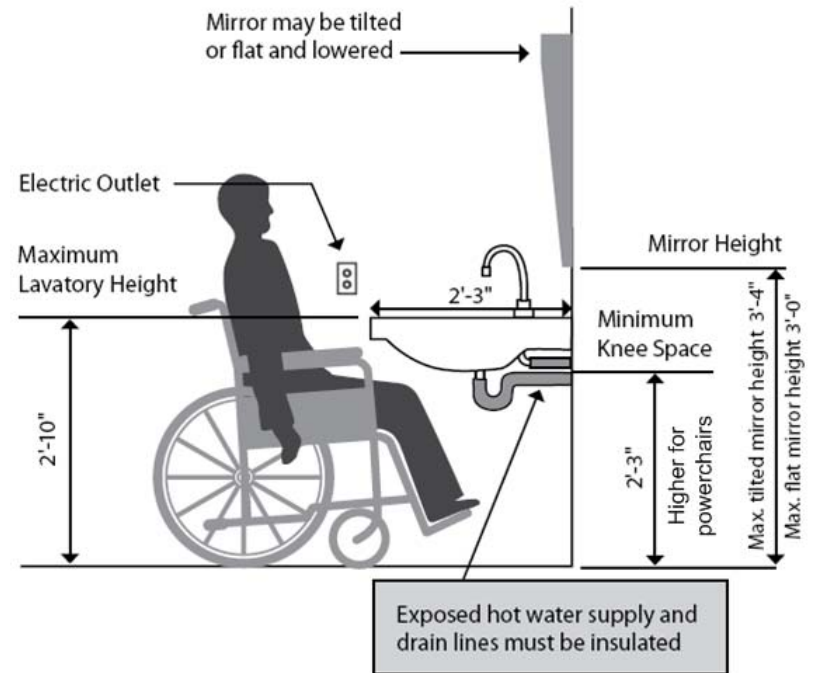

Fig. 5.3 Lavatory

- 5.2.10. A vanity with a built-in basin offers an attractive and functional alternative to a lavatory. However, adequate knee space must be provided below the basin.
- 5.2.11. The vanity height should not exceed 2'-10". The knee space below the vanity should be at least 2'-3" high and 3'-0" wide. Vanity tops should be approximately 2'-3" deep. All exposed edges of the vanity top should be rounded.
- 5.2.12. Faucets should be no farther than 1'-9" from the front edge of the vanity. This distance corresponds to the comfortable forward reach of an individual in a seated position.

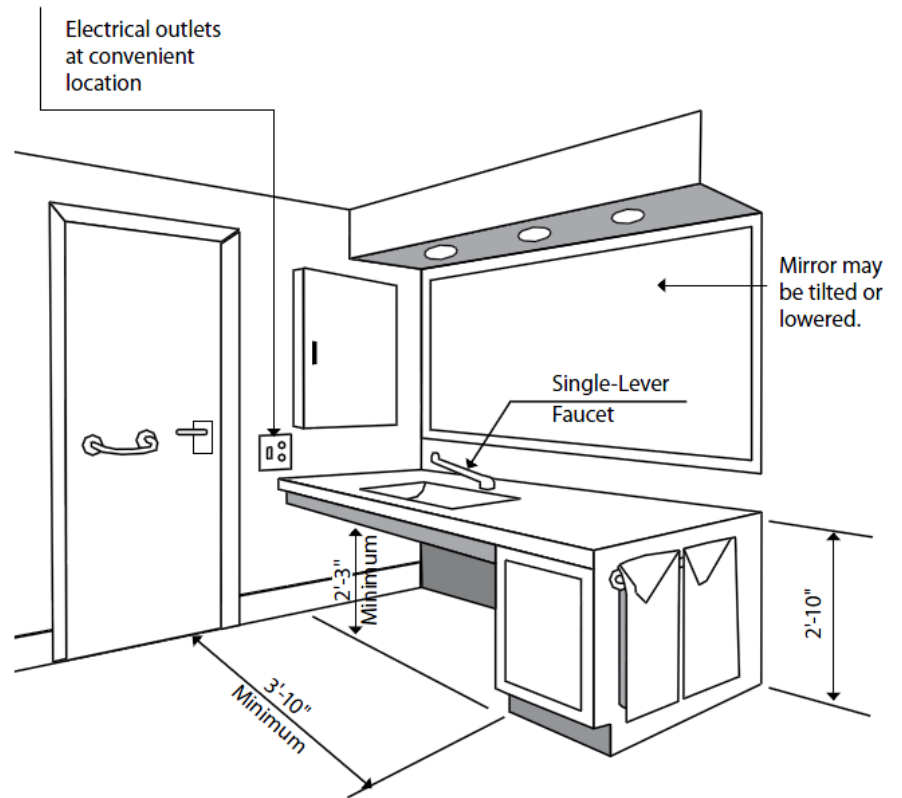

Fig. 5.4 Vanity

5.3. Transfer Techniques

Two common techniques for transferring from a wheelchair to a toilet are illustrated (Figures 5.5 and 5.6). Each person has a favored technique, including a preference for left or right transfer. The design should accommodate the preferred technique, and the fixture should be located accordingly.

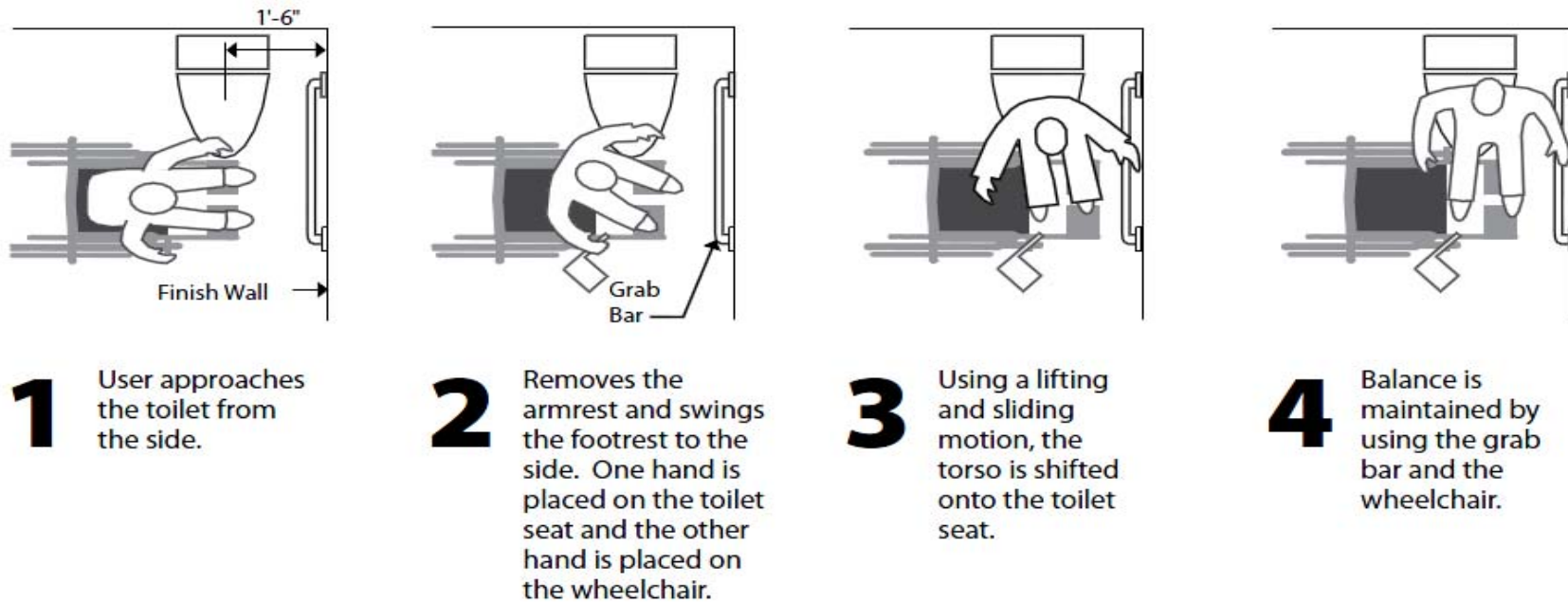
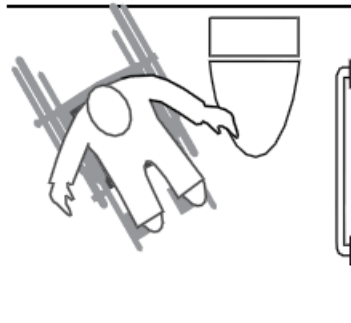
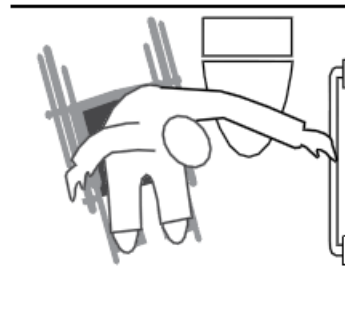

Fig. 5.5 Side Transfer Sequence



1 The wheelchair is positioned as close as possible to the toilet.



2 The armrest is removed from the wheelchair.

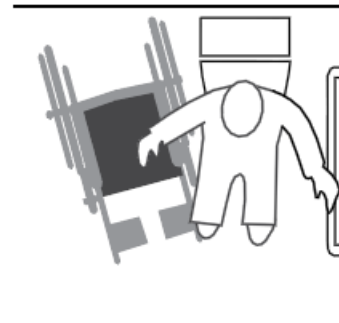

3 The user reaches across to the grab bar and slides sideways to the seat.

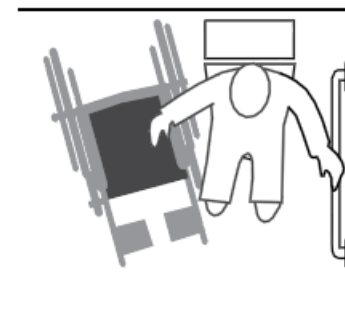

4 The user maintains balance by using the grab bar and the wheelchair.

Fig. 5.6 Parallel Transfer Sequence

5.4 Bathtubs

Some wheelchair users prefer a bathtub to a shower. The bathtub location must allow easy approach and adequate space to position a wheelchair for transfer. Tub orientation should take into consideration the individual's preference for left or right transfer.

- 5.4.1. Ideally, the bathtub should be 1'-8" high.
- 5.4.2. A platform or seat at the end of the bathtub helps the wheelchair user transfer to and from the bathtub. This platform should be at the same level as the bath rim and of the same width as the bathtub. The design must provide a clear area beside the platform to position a wheelchair for transfer.
- 5.4.3. Grab bars or a hoist or stirrup grip suspended from the ceiling should be provided to aid the transfer. Grab bars along one side of the tub provide support during bathing.

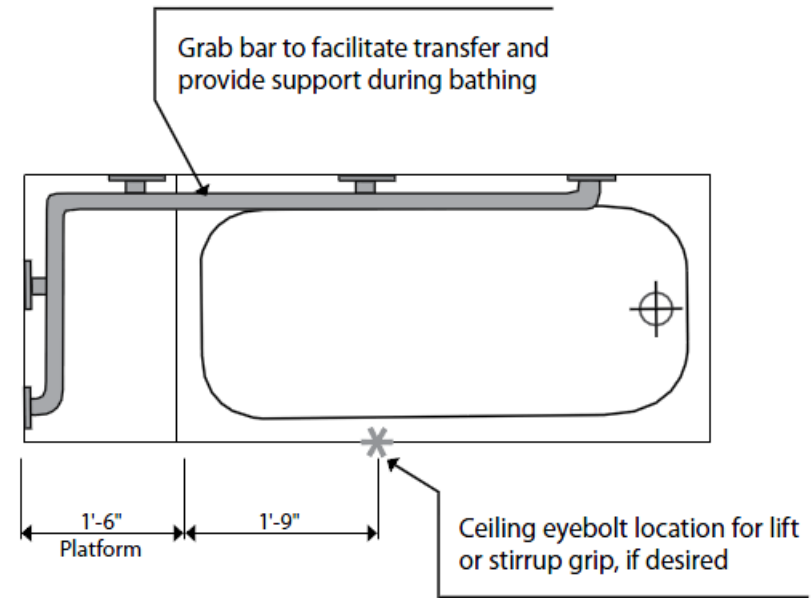

Fig. 5.7 Bathtub

- 5.4.4. Bathtub controls must be easily accessible, both outside and within the tub. Some individuals may prefer side-mounted controls and remote control drain operation.
- 5.4.5. The most flexible option is the combination bathtub and shower. It can be used by a person sitting in the bathtub, seated on the platform, or standing in the bathtub. A handheld showerhead should be provided, and all controls must be accessible from the platform or the bathtub. Thermostatic controls must be provided to prevent sudden changes in water temperature. Most plumbing codes require a vacuum breaker to be installed in a handheld shower, to prevent contamination of potable water.

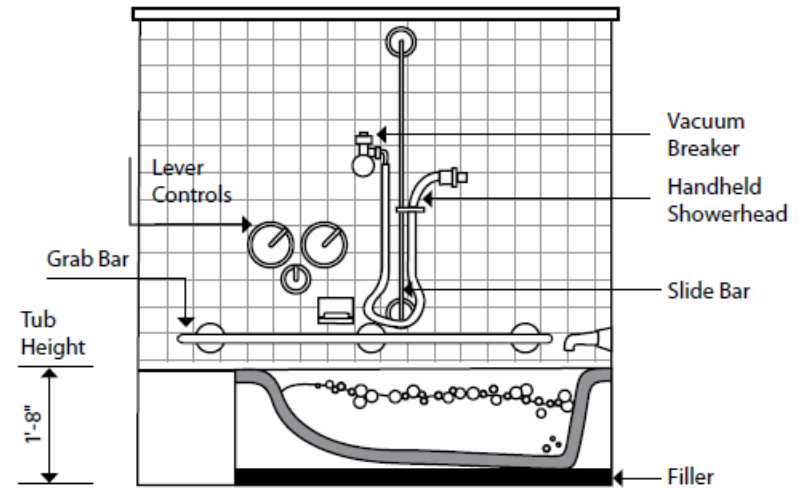

Fig. 5.8 Combination Bathtub/Shower

5.5 Showers

Many wheelchair users prefer showers to baths because transfer is less difficult or not necessary at all for a shower. There are two types of showers. The first is equipped with a seat to which the individual transfers from the wheelchair (See Figure 5.10). The second is a roll-in shower (See Figure 5.11). To use a roll-in shower, the user sits in a second wheelchair (usually stored in the shower itself) and showers in this wheelchair. In both types of showers, a wheelchair must partially or fully enter the shower. Therefore, shower entranceways must have no curbs and be at least 3'-6" wide.

- 5.5.1. The minimum size of any roll-in shower is 5'-0" by 4'-0". The minimum shower opening 3'-6" wide, except where a door is provided for a roll-in shower (Figure 5.11).
- 5.5.2. Showers must not have curbs or thresholds that impede wheelchair access.
- 5.5.3. Shower floors (as well as bathroom floors) must be nonslip.
- 5.5.4. Thermostatic controls must be installed to protect the user from sudden changes in water temperature. Many people find lever-handle temperature controls easiest to operate. All controls must be easily accessible to the shower occupant.

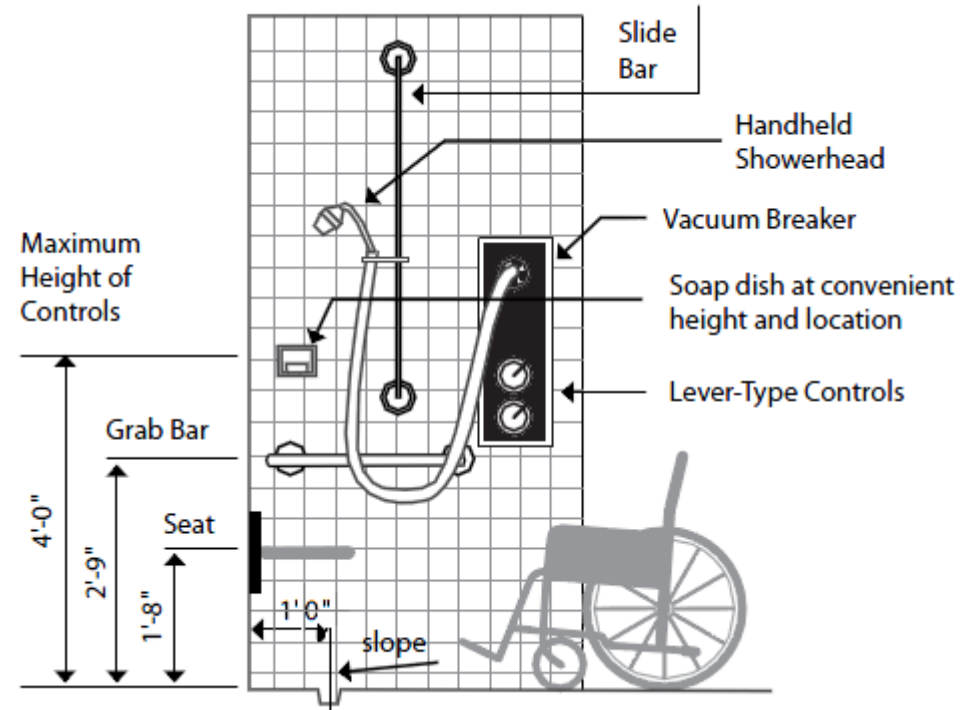

Fig. 5.9 Shower

5.5.5. A bench seat may be installed in the shower. The seat should be mounted at a height of approximately 1'–8". It may be hinged to fold up against the wall when not in use. Grab bars or a suspended stirrup grip should be provided to aid in transfer to the seat. Grab bars also provide support during showering.

5.5.6. Shower seats should be installed taking into consideration the user's preference for left or right transfer.

5.5.7. All showers should be equipped with a flexible hose and handheld showerhead. The handheld showerhead should be stored within easy reach of the user.

5.5.8. Curtains are usually provided to help keep water in the shower. Small wing walls may be installed if they do not interfere with access transfer. Doors are sometimes used with roll-in showers and may incorporate a rubber sweep strip to prevent the escape of water. Shower doors must meet all the requirements that apply to other interior doors (See Doors, Section 4.2).

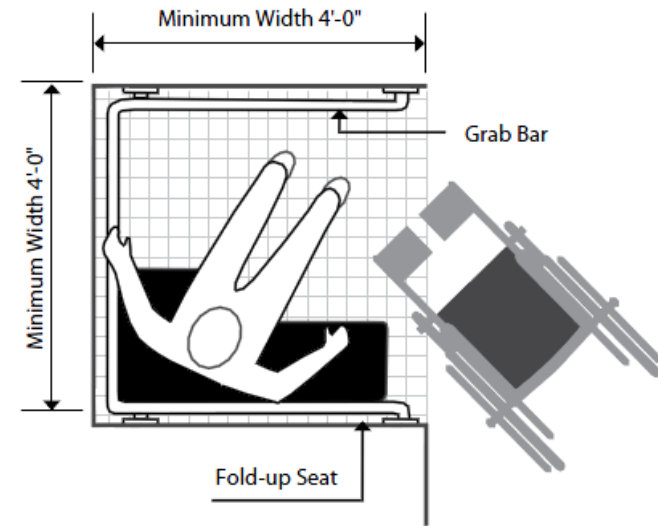

Fig. 5.10 Shower Seat

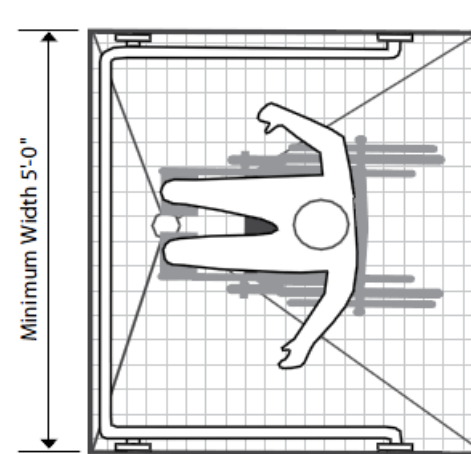
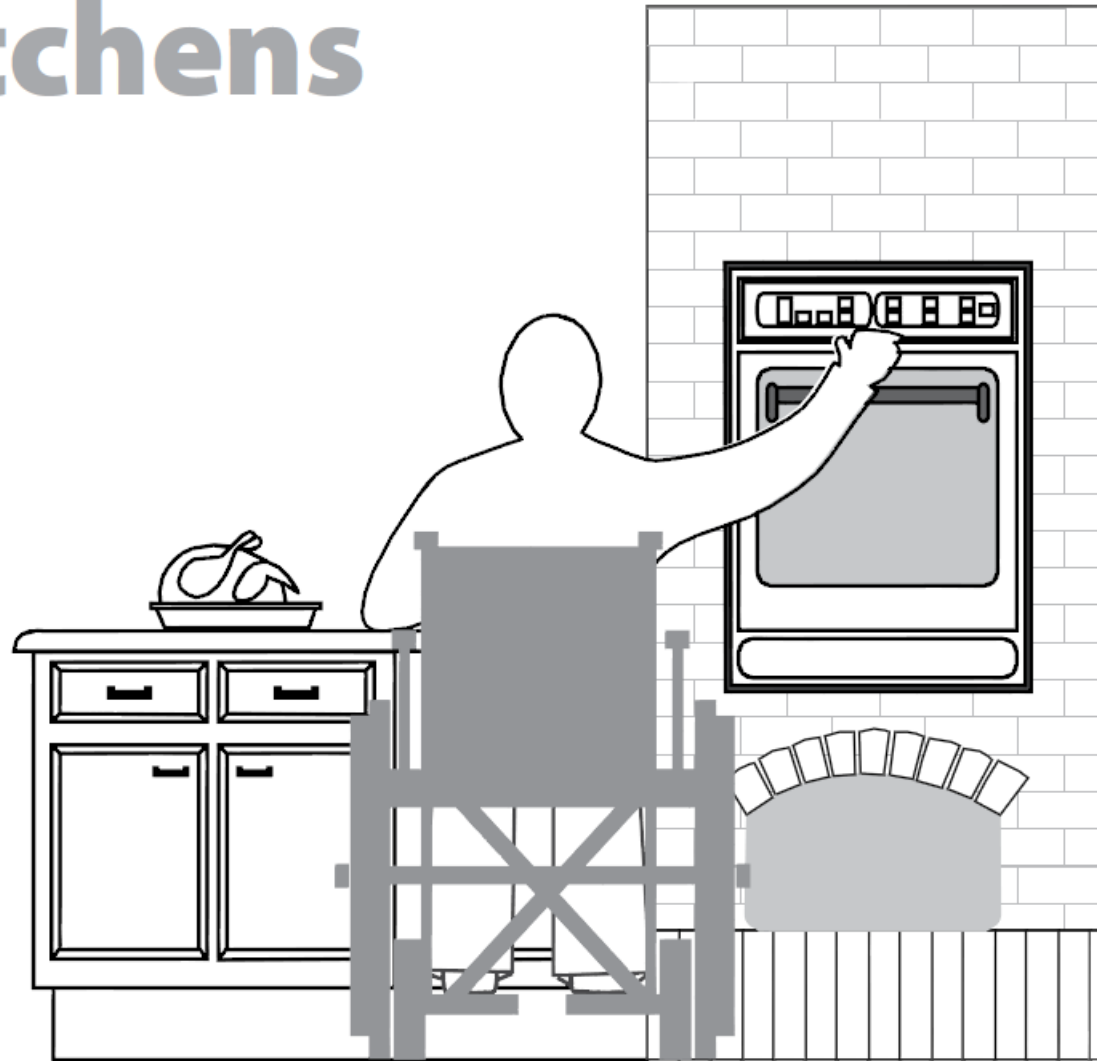

Fig. 5.11 Roll-in Shower

Kitchens



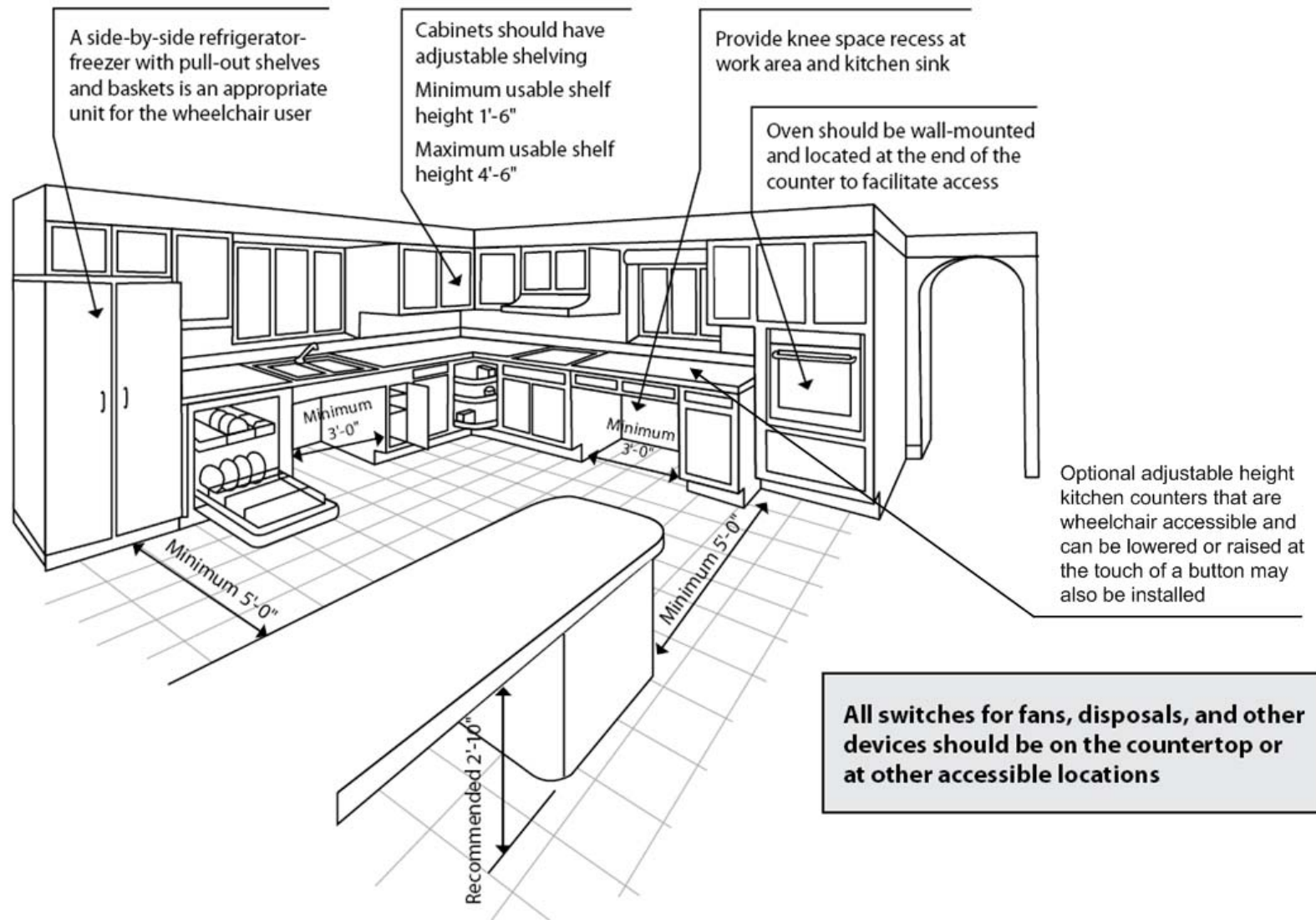

Fig. 6.1 Kitchen Arrangement

6.2. Work Areas

Adequate counter space should be provided. The standard kitchen counter height is 3'-0", which is approximately 2" to 3" higher than the convenient height for a wheelchair user. Although, the standard counter height is acceptable, at least one work area must be provided that allows a seated person to prepare food. This work area should be conveniently located in relation to all kitchen appliances.

- 6.2.1. The work area should be no higher than 2'-10", and a recess at least 3'-0" wide must be provided below.
- 6.2.2. Two types of work area counters are illustrated. The first type (Figure 6.3) provides a recess that is only high enough to accommodate the wheelchair user's legs and knees. Wheelchair armrests (unless they are removed) limit the user's access to the counter. Since the comfortable forward reach is approximately 1'-9" from the front of the counter, any counter space deeper than 1'-9" is unusable. In many instances, this design is acceptable; however, the designer should be aware of its limitations. Such a workspace should have at least a 2'-3" knee space clearance area.

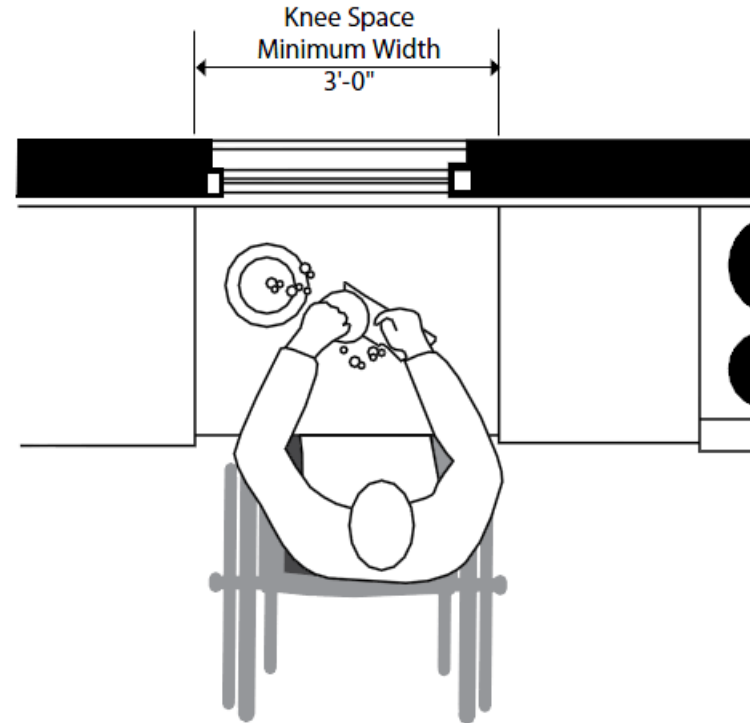

Fig. 6.2 Knee Recess Work Area

6.2.3. The second type of counter (Figure 6.4) allows the wheelchair user to get closer to the countertop. To accommodate the wheelchair armrests, the recess should have a minimum height of 2'-6". This recess should have a minimum depth of 2'-0" so that the approach is not limited by the wheelchair footrests.

6.2.4. Pullout lap boards at a suitable height also provide convenient work space.

6.2.5. The kitchen work area is a convenient location for a landline telephone extension.

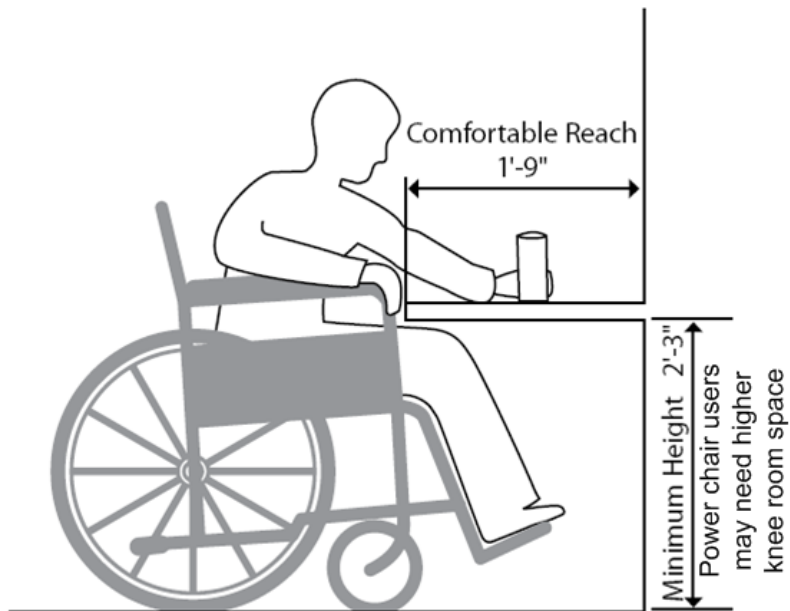

Fig. 6.3 Knee Space Clearance

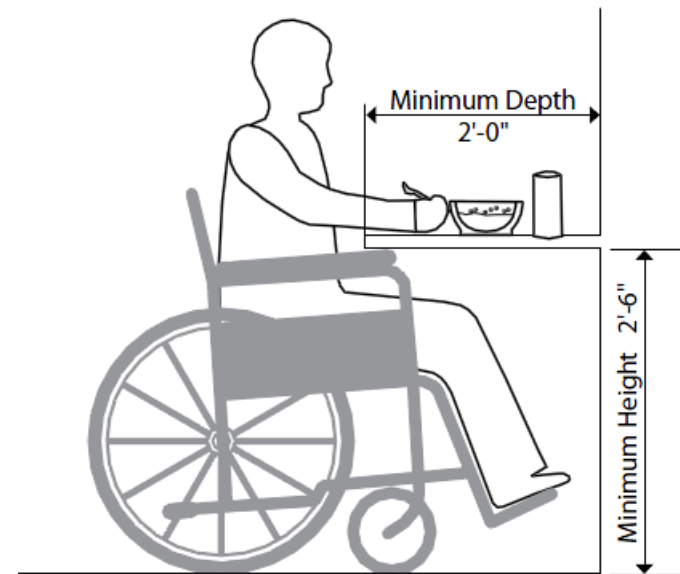

Fig. 6.4 Armrest Clearance

6.3. Kitchen Sinks

Three essential characteristics of a kitchen sink allow a user to work in a seated position: (1) the sink must be at a comfortable height with all controls within easy reach; (2) there must be adequate space underneath the sink for the knees; and, (3) the user must be protected from all sources of heat, including hot water from the faucet.

- 6.3.1. The kitchen sink should be no higher than 2'-10". Controls should be lever-type and located no farther than 1'-9" from the front edge of the counter.
- 6.3.2. Sinks should be no deeper than 5". A level counter area 2" to 3" in front of the sink should be provided for arm support.

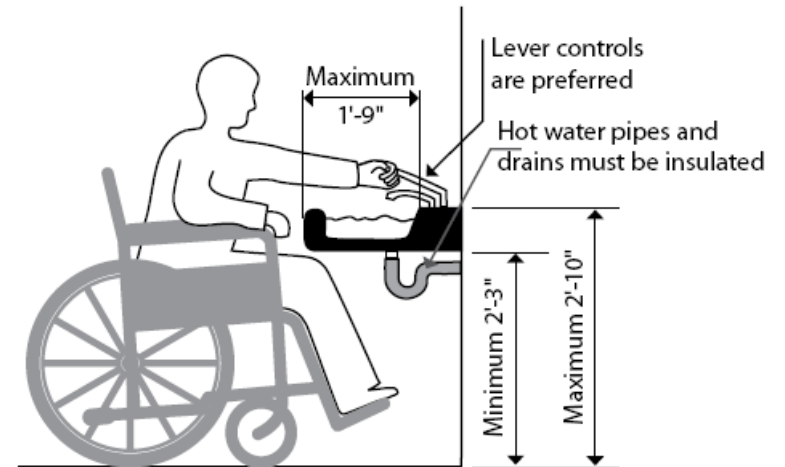

Fig. 6.5 Sink with Knee Space

- 6.3.3. A pullout spray attachment is useful for rinsing dishes, filling pots, and cleaning the sink.
- 6.3.4. A knee recess area at least 2'-3" high and 3'-0" wide must be below the kitchen sink. Positioning the drain at the back of the sink allows for the maximum knee space.
- 6.3.5. Insulation must be provided around any source of heat, including the sink, all supply and drain pipes, and dishwasher connections.
- 6.3.6. Disposals should be provided whenever possible. The disposal motor must be enclosed to protect the user from shocks and burns. Although installation of a garbage disposal limits the knee space below the sink, this loss can be minimized by locating the drain at the back of the sink and off to one side. A better solution is to install a separate disposal sink to one side of the knee recess (Figure 6.7).

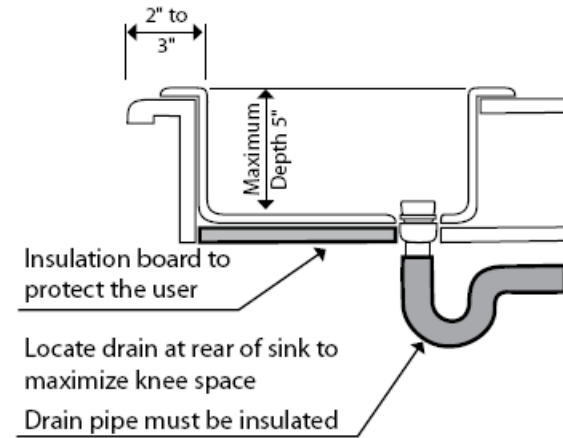

Fig. 6.6 Sink

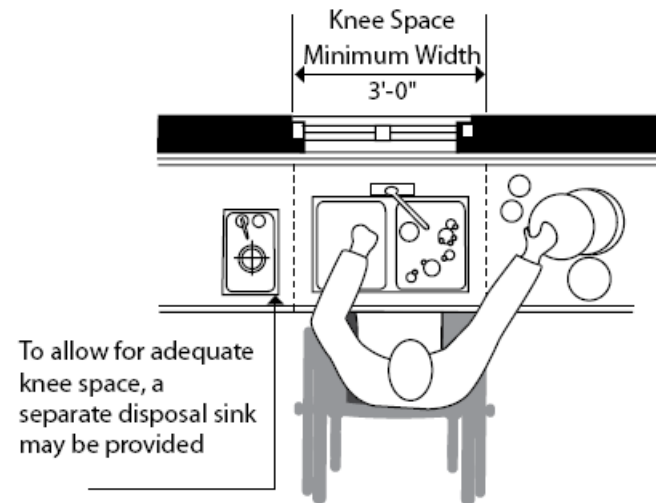

Fig. 6.7 Disposal Sink

6.4. Ovens

The conventional range design with burners on top and an oven below is unacceptable for the wheelchair user. The oven in such units is mounted too low to permit the wheelchair user convenient access. Typically, the oven has a bottom-hung door, which further restricts access to the oven. An appropriate alternative is a wall-mounted oven and a counter-mounted cooktop.

- 6.4.1. The cooktop should be mounted no higher than 2'-10" to allow a seated person to see the food while it is cooking. Even at 2'-10", food on the back burners may be difficult to see. To overcome this problem, a mirror can be mounted at an angle above the cooktop. However, mirrors mounted in this way may be difficult to clean. The cooktop should have a ceramic surface or burners flush with the surface to reduce the possibility of spills. Also, the cooktop should be flush with the counter.

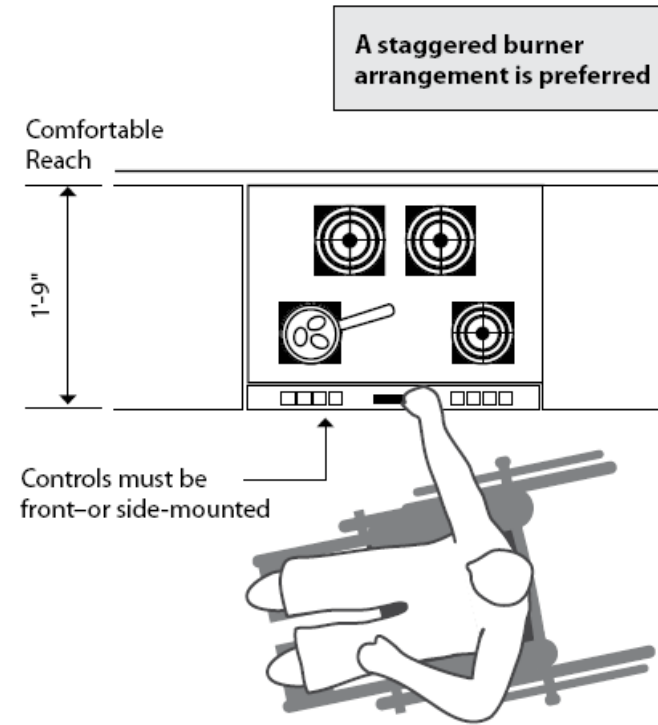

Fig. 6.8 Counter-Mounted Cooktop

- 6.4.2. Cooktop controls must be front- or side-mounted because it is dangerous for a seated individual to reach across a hot cooking surface to adjust the controls. The burner arrangement should be staggered or offset to allow the use of back burners without reaching over the front burners. Cooktops should be as shallow as possible to minimize the reach to the back burners.
- 6.4.3. Switches for the cooktop exhaust fan and light switches must be easily accessible. Switches should be mounted on the counter if the controls on the exhaust hood are more than 4'-0" above the floor.
- 6.4.4. The bottom of wall-mounted ovens should be approximately 2'-6" to 2'-10" above the floor. This height is convenient to the wheelchair user and normally allows knee space below the door. While side-hung oven doors permit the wheelchair user to get closer to the oven, bottom-hung doors protect the user from spills. In either case, it is best to locate the oven at the end of a counter to allow approach from the side. Counter space should be provided adjacent to the oven.
- 6.4.5. Microwave ovens are a great convenience, but they pose a danger to individuals with heart pacemakers.

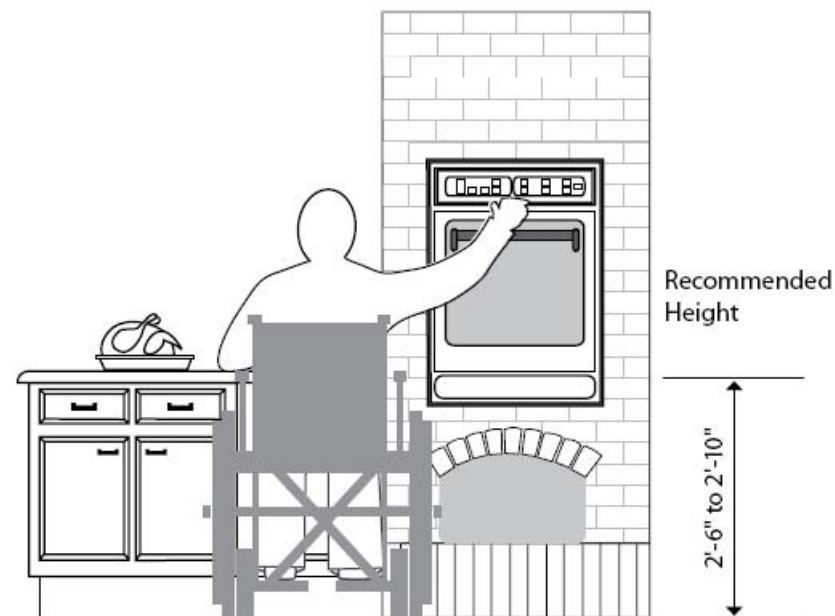

Fig. 6.9 Wall-Mounted Oven

Safety Considerations



Metric Conversions

Because of the accepted practice in the United States to use common U.S. units of measurement for building and construction, U.S. units of measurement have been used

throughout this publication. Conversion to metric units is provided in the table below. Numerous websites also provide metric conversions.

TABLE OF CONVERSION FACTORS TO METRIC (S.I.) UNITS			
Physical Quantity	To convert from	to	multiply by
Length	inch	meter	2.54×10^{-2}
	foot	m	3.048×10^{-1}
Area	inch ²	m ²	6.4516×10^{-4}
	foot ²	m ²	9.290×10^{-2}
Volume	inch	m ³	1.639×10^{-5}
	foot	m ³	2.832×10^{-2}
Temperature	Fahrenheit	Celsius	$t_c = (t_f - 32)/1.8$
Temperature difference	Fahrenheit	Kelvin	$K = (\Delta t_f)/1.8$
Pressure	inch Hg (60F)	newton/m ²	3.377×10^3
Mass	lbm	kg	4.536×10^{-1}
Mass/unit area	lbm/ft ²	kg/m ²	4.882
Moisture content rate	lbm/ft ² week	kg/m ² s	8.073×10^{-6}
Density	lbm/ft ³	kg/m ³	1.602×10^1
Thermal conductivity	Btu/hr ft ² (F/inch)	W/(mK)	1.442×10^{-1}
U-value	Btu/hr ft ² F	W/(m ² K)	5.678
Thermal resistance	F/(Btu/hr ft ²)	K/(W/m ²)	1.761×10^{-1}
Heat flow	Btu/hr ft ²	W/m ²	3.155

Index

Bathrooms

arrangements. 38–42
bidet. 40
grab bars 38, 40, 43, 48
hot water pipes 41
mirrors. 41, 42
shelves 38, 39, 41
shower. 38, 45, 46, 47
toilet. 4, 38, 40, 43, 44
transfer 38, 39, 40, 43–44, 45, 47–48
tub 38
vanity 42

Bedrooms 20, 21, 22, 23

Carpets 20, 23

Carports 16

Ceiling Supports

baths. 45

Closets 22, 34

Cooktops. 56, 57

Corridors 33

Counters 4, 5, 32, 50, 51, 52–53, 54, 56, 57

Dishwashers. 50, 55

Disposals. 50, 51, 55

Doorbells 14

Doors

accordion doors. 28, 34

closet doors 34

dimensions 26

entry doors 9, 14, 21

hardware. 26, 27, 28

kickplates 29

operation. 26–27

shower doors. 48

sliding doors. 28, 34

swing. 26, 27, 33, 39, 60

Electrical Outlets 4, 5, 31, 32, 38, 41, 42

Emergency Call. 60

Exits. 11, 22, 23, 60

Floor Plans. 19–23

Freezers. 51

Finishes 10, 11, 20, 33, 50

Garages. 16–17, 23

Grab Bars

showers 46, 47–48

toilets. 38, 40, 43, 44

tubs. 45, 46

Handrails

ramps 10, 11

stairs 12–13

walks 10, 11

Inclined Elevator. 35

Insulation

for doors 14

for pipes. 41, 54, 55, 60

walls and windows. 20

Kitchens

arrangements. 50–51

cabinets 50, 51

counters 50, 51, 52, 53, 54, 56, 57

refrigerators. 50, 51

sinks 50, 51, 54–55

work areas. 50, 51, 52–53

Lapboards 53

Index (continued)

- Laundry
 - washers and dryers 23
 - Lavatory 4, 38, 40, 41, 42
 - Light Switches 16, 17, 31, 57
 - Mirrors. 5, 41, 42, 56
 - Metric Conversion. 61
 - Multi-story Homes 35
 - Ovens. 51, 56, 57
 - Platforms
 - at entrance. 14, 15
 - at ramps 10
 - at tubs 45, 46
 - on stairs. 35–36
 - Parking. 8, 16
 - Patios. 8, 21
 - Ramps
 - dimensions 10, 11
 - fire-retardant 11
 - handrails. 10, 11, 12–13
 - slope. 10, 11
 - surface. 10, 11
 - Refrigerators. 50, 51
 - Shelves
 - bathroom. 38, 39, 41
 - closets 34
 - kitchens. 50, 51
 - Sidelights. 15
 - Sinks. 32, 50, 51, 54, 55
 - Switches 16, 17, 31, 51, 57
 - Showers. 20, 38, 46, 47–48
 - Stairs
 - handrails 12
 - inclined elevators 35
 - risers 11, 35
 - wheelchair lifts 35
 - Telephones
 - locations. 39, 53, 60
 - wall-mounted. 32
 - Thresholds. 14, 28, 47
 - Transfer
 - to bed. 22
 - to car. 16, 17
 - to shower. 38, 48
 - to toilet. 38, 39, 40, 43–44
 - to tub. 38, 45
 - Turning Space. 2, 3, 4, 10, 38
 - Vanity. 42
 - Walks. 8, 9, 10–11
 - Wall Protection. 33
 - Weather Stripping. 14, 20, 30
 - Wheelchair Lifts. 35–36
 - Wheelchairs
 - dimensions. 2–5
 - turning radius. 2, 3, 4, 10, 38
 - Work Areas. 4, 50, 51, 52–53
 - Windows. 5, 20, 30
 - Zone-Control Heating. 20
-



VA Pamphlet 26-13
August 2009
Veterans Benefits Administration
Department of Veterans Affairs
Washington, DC 20420