



Department of Energy
Washington, DC 20585

January 3, 2013

The Honorable Peter S. Winokur
Chairman
Defense Nuclear Facilities Safety Board
625 Indiana Avenue, NW, Suite 700
Washington, DC 20004

Dear Mr. Chairman:

This letter transmits to you the latest revision of the Technical Work Plan and the Project Plan for the Department of Energy (DOE) project to develop verification and validation (V&V) test problems and solutions for the System for Analysis of Soil-Structure Interaction (SASSI) computer code. This project stems in part from our commitments to address SASSI technical and software quality assurance issues that were made to the Defense Nuclear Facilities Safety Board (DNFSB) in the letter dated July 29, 2011, and a follow-up letter dated October 5, 2011.

Over the past year, my office, in conjunction with the National Nuclear Security Administration (NNSA), has sponsored and collaborated with the community of expert users, including the DNFSB staff, on the SASSI V&V project. On November 15-16, 2012, we hosted the second project meeting to inform interested parties on the results to date and discuss the path forward. Five DNFSB staff members participated in this meeting and provided valuable insights for the project technical integrators to consider. Throughout this effort, DOE has sought, and will continue to seek, the staff's technical expertise and contributions to the Technical Work Plan, Project Plan, and project meetings. Please note that the Technical Work Plan and Project Plan will continue to be revised as the project progresses and evolves. For example, comments received on this latest revision, and additional details on acceptance criteria for comparing SASSI results with benchmark solutions, will be incorporated into a future revision of the Technical Work Plan.

As detailed in the enclosed documents, the SASSI V&V project is composed of two phases. Phase one is to demonstrate whether SASSI results are valid for the range of soil properties, seismic input, and structural geometries associated with the Uranium Processing Facility (UPF) at the Y-12 National Security Complex and the Chemistry and Metallurgy Research Replacement (CMRR) facility at Los Alamos National Laboratory. Phase two is to develop more extensive V&V test problems and their solutions that apply to facilities across the DOE complex, which would lead to the development of a guidance document for using SASSI in diverse settings. Phase one consists of nine specific tasks. The task calculation packages are provided to DNFSB staff for review as they become available. The final report from phase one is expected by June 30, 2013, which will support the UPF project schedule.



If you have any questions, please contact me at (202) 586-0799.

Sincerely,

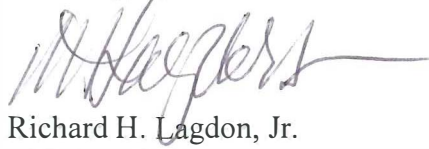
A handwritten signature in black ink, appearing to read "R. Lagdon, Jr.", with a long horizontal flourish extending to the right.

Richard H. Lagdon, Jr.
Chief of Nuclear Safety
Office of the Under Secretary for Nuclear
Security

Enclosures

cc:

T. D'Agostino, S-5
S. McDuffie, CNS EM-40
M. J. Campagnone, HS-1.1
M. Do, HS-1.1
D. Nichols, NA-SH-1
M. Thompson, NA-16
P. Rhoads, NA-17
S. Feddis, NA-164
J. Michele, NA-164
T. Williams, NA-SH-40
T. Robbins, NPO
B. Gutierrez, SRS

Project Plan: Verification and Validation of the System
for Analysis of Soil-Structure Interaction (SASSI)
Computer Code

Department of Energy (DOE) Technical/Project Lead

B. Gutierrez

Project Sponsors

R. Lagdon, Chief of Nuclear Safety, Office of Environmental Management

D. Nichols, Chief of Defense Nuclear Safety, National Nuclear Security
Administration

T. Robbins, DOE Deputy Federal Project Director the Uranium Processing
Facility

T. Whitacre, DOE Engineering and Construction Lead Chemistry Metallurgy
Research Replacement Facility

Project Plan: Verification and Validation of SASSI

Revision 2
November 19, 2012

Plan Prepared by:



Dr. Brent J. Gutierrez
DOE Technical/Project Lead

11/19/2012

Date

Plan Reviewed by:



Mr. Thomas W. Houston
Carl J. Costantino & Associates

11/19/2012

Date



Dr. Carl J. Costantino
Carl J. Costantino & Associates

11/20/12

Date



Debra Sparkman
DOE Office of the Chief of Nuclear Safety

11/23/2012

Date



Dr. James J. Johnson
Project Technical Integrator

11/19/2012

Date

Plan Approved by:

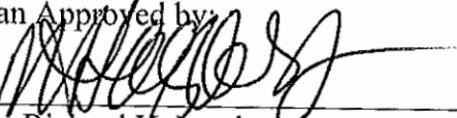

Mr. Richard H. Lagdon
DOE-EM Chief of Nuclear Safety

11/19/2012

Date

RECORD OF REVISION

Revision Number	Pages Revised	Revision Date	Description of Revisions
November 16, 2011	All	November 16, 2011	Initial issue
December 23, 2011	All	December 23, 2011	Minor edits
Revision 2	All	November 19, 2012	Signature page Revision log Reorganized sections Updated references Clarified SASSI version references

CONTENTS

RECORD OF REVISION.....	iii
INTRODUCTION	1
OBJECTIVES	2
WORK PROCESS	3
PROJECT ORGANIZATION AND LINES OF COMMUNICATION	5
WORK ACTIVITIES	9
SCHEDULE.....	11
QUALITY ASSURANCE	12
REFERENCES	12

INTRODUCTION

Seismic analysis and design of high-hazard nuclear facilities require evaluation of soil-structure interaction (SSI) effects between the building and its supporting soil. There are several variations of the computer program System for Analysis of Soil-Structure Interaction (SASSI) that have been, and continue to be, used extensively for this purpose within the Department of Energy (DOE) complex, as well as in the commercial nuclear power industry. Over time, SASSI became the *de facto* standard for calculating soil seismic interaction for nuclear structures in the DOE complex.

Recently, SASSI users have identified technical and software quality assurance (SQA) issues with this software. Although the code has been demonstrated to meet computational needs for many projects over many years, issues have arisen recently that could have undermined the confidence in continuing the employment of the tool for DOE nuclear facility applications. In particular, as had been discovered at Los Alamos National Laboratory (LANL) in the summer of 2010, a computational anomaly only associated with the use of the subtraction method was discovered in the algorithm that led to physically unrealizable soil structure responses. In August 2010, LANL published LA-UR-10-05302, *Seismic Response of Embedded Facilities Using the SASSI Subtraction Method*, which identified the issues with the subtraction method.

Investigation of this matter uncovered the additional concern that the quality assurance (QA) pedigree of the SASSI code and its verification and validation (V&V) history was not fully traceable. At that time, the Chief of Nuclear Safety (CNS) commissioned several SASSI experts to examine the subtraction method issues. On April 8, 2011, the Defense Nuclear Facilities Safety Board (DNFSB) issued a letter to DOE itemizing a number of technical and SQA issues related to the SASSI computer program. This letter expressed a concern that the issues could lead to erroneous conclusions that affect safety-related structural and equipment design at DOE defense nuclear facilities.

The DNFSB April letter and staff report indicated that, based upon information obtained from the Board's survey of DOE projects, there is a wide variation in the implementation of SQA requirements applied to the SASSI computer program. The DNFSB letter and staff report further indicated that there is no consistent set of test problems to verify that the SASSI computer program meets its intended functions and that it does not perform any unintended functions for the types of design situations being faced by DOE. The variety of SQA implementation is being addressed through DOE SQA assessments and associated corrective actions. The consistency of available test problems is being addressed by this Project Plan.

On July 29, 2011, DOE responded to the April 8, 2011, DNFSB letter to address the identified SASSI issues. The response indicates that a number of activities will be performed to provide documented verification requirements and an expanded set of test problems that can be used to validate that SASSI meets its requirements. The process used to develop these documents will incorporate input from outside experts. The set of test problems and solutions will provide future users with greater assurance that SASSI results are reliable for a given site and will also facilitate SASSI users' long-term implementation of SQA requirements.

DOE also committed to create a supplemental guidance document for DOE users that will accompany the set of test problems and solutions. The supplemental guidance will highlight software functions that need to be verified before executing the code for safety-related design activities. It will also communicate nuances to executing the code and any other information that DOE finds important for users to consider. Guidance for defining the finite element method (FEM) for SSI analyses will also be included.

The development of this Plan is in response to the DOE September 29, 2011, memorandum from the National Nuclear Security Administration (NNSA) to the Site Managers for the Chemistry and Metallurgy Research Replacement (CMRR) Facility and the Uranium Processing Facility (UPF) projects, which are currently in design. The Plan outlines the DOE project to develop a systematic V&V program to ensure the accuracy of SSI simulations performed by various implementations of the SASSI computer program derived from University of California at Berkeley (UCB) development of SASSI V1.0 in 1981. The original SASSI computer code and its subsequent UCB-developed versions for which source code was made available (i.e., UCB SASSI2000 V1.0) have been modified by various engineering firms, creating numerous variations of the SASSI computer code. For activities involving the use of a SASSI computer program, this project refers to Structural Dynamics Engineering (SDE)-SASSI V2.0, a derivative of UCB SASSI V1.0.

The purpose of this plan is to describe the activities required to develop the documented verification requirements, the set of test problems that can be used to validate that the core solution algorithms within the SASSI computer program meets its requirements, and supplemental guidance for use by SASSI users. It provides a plan for deliverables and assigns responsibilities, authority, and accountability for the work and work products and incorporates the input from outside experts from academia and from interested SASSI users and experts. Since the CMRR and UPF projects are in design, the activities and deliverable described in this plan are scheduled to support the needs of the projects. A separate document, the Technical Work Plan (TWP), provides the description of the test problems and range of parameters to be evaluated based on the results of interaction between the PPRT, Technical Integrator (TI), and Implementor Team (IT).

OBJECTIVES

The overall objective of the SASSI V&V project is to develop an up-to-date assessment of the accuracy of the solution algorithms used to compute SSI responses over the range of input parameters consistent with the site and structural characteristics of nuclear facilities currently in design or being evaluated for updated seismic demands.

The suite of test problems sufficient to validate that SASSI meets its requirements and the SASSI guidance document will be of value to SASSI users who are involved in conducting SSI analyses or developing and maintaining computer software to conduct SSI analyses. In addition, the products from this project will enable project developers to demonstrate that the implementation of the SASSI computer program used to predict seismic response for the individual facilities analyzed will perform the calculations in a sufficiently accurate manner. Finally, the products

from this project will provide a consistent set of test problems and user guidance to provide a baseline from which peer reviewers and regulators (e.g., DOE and NRC) and government oversight agencies (e.g., DNFSB) can assess the adequacy of the modeling and predicted response of particular facilities.

Having identified the numerical anomaly previously, the first objective of the project is to describe the technical bases for the cause of the anomaly and to establish a process to be used to evaluate the adequacy of the computed SSI response using the subtraction method. The second objective of the project is to develop a suite of test problems that are adequate to demonstrate that simulations performed by the implementations of the SASSI computer program lead to numerical responses that are sufficiently accurate for the assumptions embedded within the SASSI SSI formulation. The accuracy of computed responses also needs to be shown to be appropriate over a range of input parameters consistent with the use of the program for SSI analyses for sites and structures that are typical of nuclear facilities. The third objective of the project includes the development of a SASSI guidance document for use by SASSI users (Practitioners) that synthesizes the results of the implementation of this project and includes a listing of input/output from test problems developed by the project.

The first and second objectives need to be accomplished near-term in support of the CMRR and UPF projects. The efforts to meet the needs for CMRR and UPF are being funded and controlled by the project sponsors, Mr. Thomas Whitacre and Ms. Teresa Robbins, respectively. The third objective has wider and longer-term applicability and is being sponsored by the broader DOE community, where the project sponsors for these activities are Mr. Richard (Chip) Lagdon, the Chief of Nuclear Safety for Environmental Management (EM), and Dr. Don Nichols, the Chief of Defense Nuclear Safety of NNSA.

WORK PROCESS

The work process that will be followed in implementing the activities described in this project plan will incorporate three project meetings that are timed to occur at points where input from the PPRT and others in the industry can be most effective. The flow of the work process will be as shown in Figure 1. Processes and work products shown in the figure will be performed as described in the Quality Assurance section of this report.

The approach used will incorporate a systematic evaluation of the SASSI computer program. The initial focus will be at the computer program module level to demonstrate that the modules reproduce the expected physical response (e.g., the displaced shape of the soil column, the displacement field computed given a load at a layer interface) with an acceptable accuracy. Limitations on the range of FEM model parameters for which valid solutions are obtained will also be established at the computer program module level. Once the ability of the SASSI computer program to reproduce the basic solutions at the module level has been demonstrated, the ability of the system—which incorporates the interaction of multiple modules—to produce valid solutions will be demonstrated. The hierarchy of the computer program module to system relationship and the associated validation process is indicated in Figure 2.

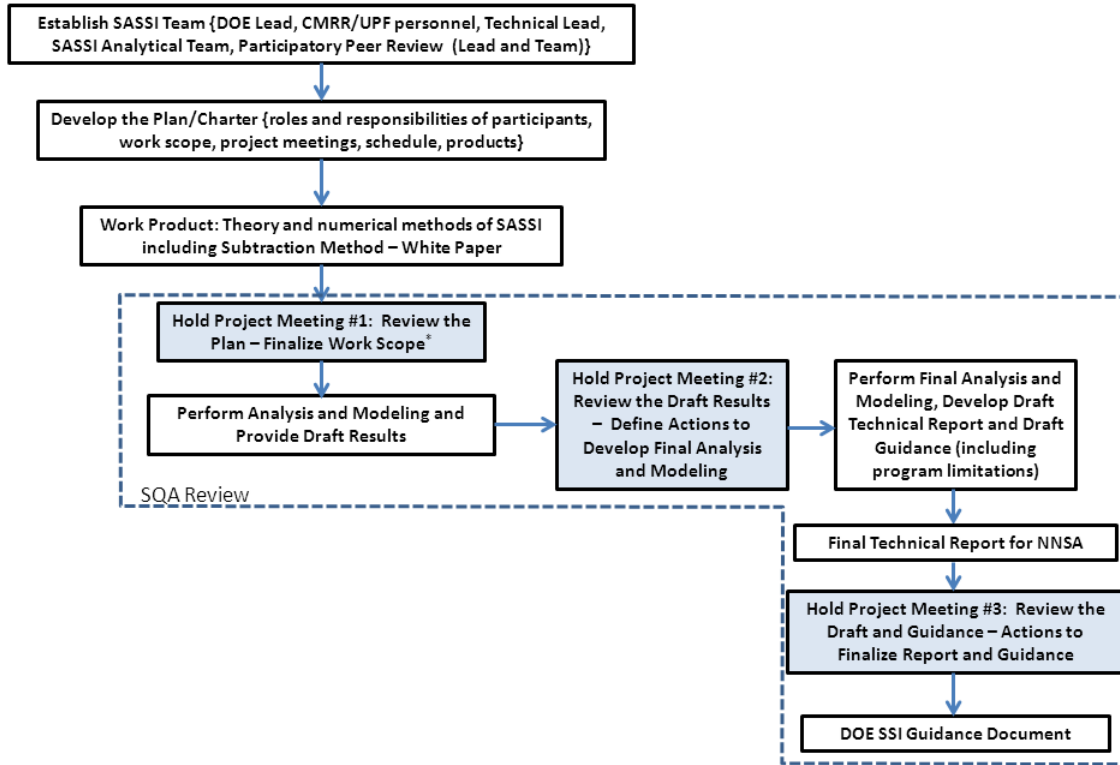

Figure 1: Work Process to Assess Technical Issues Related to SASSI

- * SASSI V&V Project plan
- ** Subtraction Method position paper

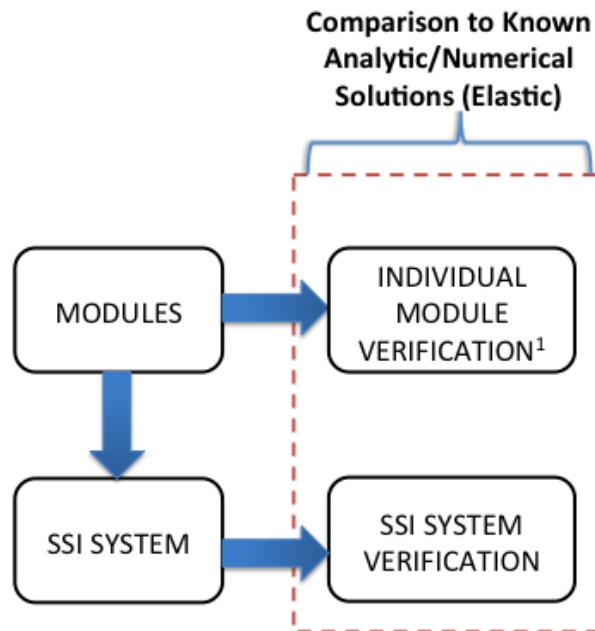

Figure 2: Hierarchy of Modules to System Relationship

¹ Sensitivities for range of parameters

Test problems to demonstrate the validity of the solutions for each of these hierarchical levels will be developed with input from the PPRT, which provides overall guidance as to the adequacy and extent of the test problems required to demonstrate that the SDE-SASSI V2.0 program solutions are appropriate. The extent of the test problems required will be consistent with the results required from the program and its modules. Thus, a set of descriptions of the required results from each module, group of modules, and overall system of modules will be developed (e.g., predicting the movement of the free field soil given a load at the control point, predicting the displacement field in the free field, predicting the response of a structure embedded in the free field given a load applied to the structure) and included in the technical work plan to ensure that the test problem set will adequately demonstrate that the program provides sufficiently accurate solutions over the range of parameters important to the SSI problem.

The results generated from developing the set of test problems and the range of parameters over which the solution algorithms as implemented by SDE-SASSI V2.0 will be documented in project calculations and reports. These results will be used, combined with the experience of team members, to develop a guidance document for use of SASSI at critical facilities of interest.

PROJECT ORGANIZATION AND LINES OF COMMUNICATION

The lines of communication are shown in Figure 3, which illustrates the flow of information and helps ensure the appropriate members of the SASSI V&V Project Team are aware of project developments and communications in a timely manner.

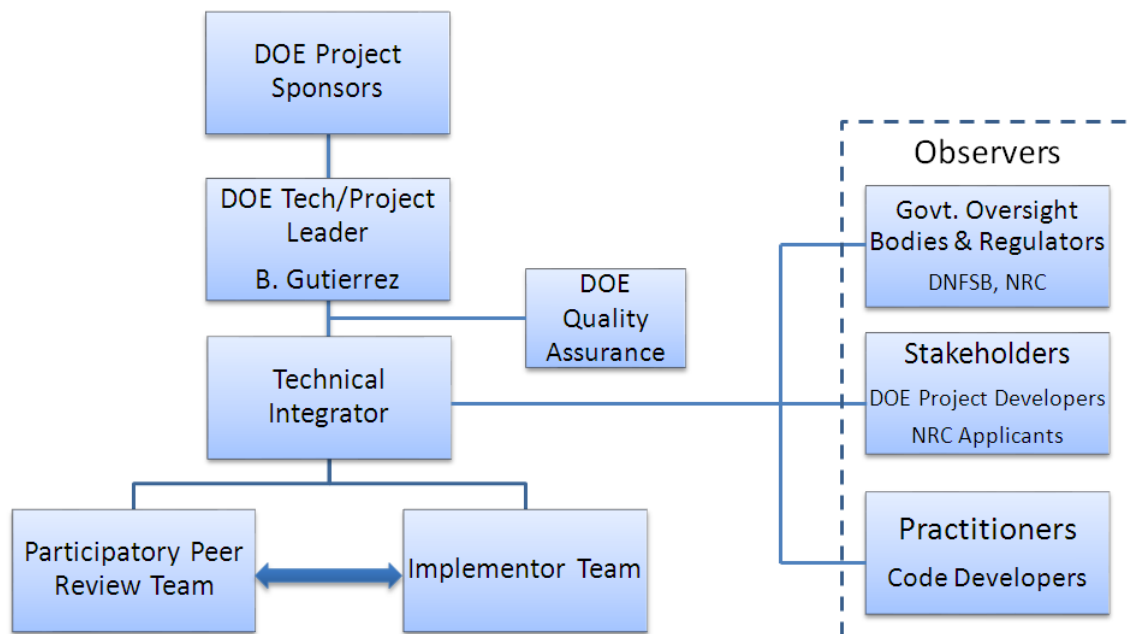

Figure 3: SASSI V&V Project Organization

DOE Project Sponsors

In the broad sense, the DOE Project Sponsors are the personnel who are ultimately responsible for ensuring that a comprehensive and technically defensible SSI guidance document is developed and used appropriately in the design and evaluation of DOE nuclear facilities: Richard Lagdon in EM and Don Nichols in NNSA. In addition, project support is being sought from the NRC, which had previously expressed an interest in sponsorship.

In the narrow sense, the Project Sponsors also include key Federal project staff members for the CMRR and UPF projects who must ensure that the SSI calculations for those projects are technically sound to support final design and construction of those facilities. They are the DOE Engineering and Construction Lead for the CMRR project, Mr. Thomas Whitacre, and the DOE Deputy Federal Project Director for the UPF project, Ms. Teresa Robbins.

The role of the Project Sponsors in the SASSI V&V project is to ensure that adequate resources are made available to enable the success of this project, and who, by their association with this project and their administrative organizations, have the authority and accountability to provide such resources.

DOE Technical/Project Lead

The DOE Technical/Project Lead is Dr. Brent Gutierrez, who is responsible for the project organization and management of the SASSI V&V Project and who, by virtue of this position through the Project Sponsors, has the authority and accountability to provide the technical direction for the project. The DOE Technical/Project Lead informs the DOE Project Sponsors of process and technical developments. The DOE Technical/Project Lead is the point of contact for transmitting correspondence and work products between the PPRT and the Project Sponsors and oversees all other project entities, and keeps apprised of all work associated with the execution of this project through the Implementor Team Lead and the Technical Integrator.

Technical Integrator (TI)

The TI, Dr. James J. Johnson, is responsible for ensuring the development of the required range of test problems and input parameters needed to demonstrate the accuracy of the SSI solution implemented by SDE-SASSI V2.0. The TI by virtue of the position has the authority and is accountable to fulfill the functions described in this section. Specifically, the TI is responsible for understanding the entire spectrum of technical information that can be brought to bear on the issue at hand. The TI gathers information relevant to SSI V&V issues from the open literature and through discussions with the IT, PPRT, and other technical experts as required.

The TI organizes and manages interactions among the project participants, identifies, and mitigates problems that may develop during the course of the study, and ensures that the participant inputs are appropriately represented and documented. He also aggregates the judgments and input of the PPRT, Observer, and IT. The TI ensures that the proper peer review is conducted to review the process and substance of the study. The TI resolves comments from

the PPRT within 30 days of receipt and government oversight bodies, regulators, stakeholders, and practitioners within 45 days of receipt.

Participatory Peer Review Team (PPRT)

The PPRT is an ongoing technical review that provides the peer reviewers with full and frequent access to the IT work products throughout the entire project. Working meetings will be scheduled between the Project meetings with the PPRT to accommodate their technical review. The PPRT is composed of three well-known, respected individuals with significant expertise in SSI analyses. These individuals are Dr. Wen Tseng, Prof. Aspasia Zerva, and Prof. Eduardo Kausel and are under contract to the DOE. The PPRT, by virtue of the position, has the authority and accountability to fulfill the functions described in this section. The prime responsibility of the PPRT is to provide an independent and transparent peer review of the work conducted by the IT for this project. In addition, the PPRT provides consensus guidance on the framework for the development of the test problems that are developed under the auspices of this project. The PPRT provides written feedback within 14 days after meetings and project meetings identifying any major issues requiring resolution. In addition, the PPRT provides a concise summary report at the conclusion of the project. PPRT work products are coordinated through the TI and the DOE Technical/Project Lead.

Implementor Team (IT)

The IT is the performing entity of this project and is composed of staff members from Carl J. Costantino & Associates (CJC&A). The IT, by virtue of the position, has the authority and accountability to fulfill the functions described in this section. The prime responsibility is to provide the deliverables, the calculations, and studies identified in the Work Activities section of this plan. Specifically, the IT:

1. Conducts studies to determine the root cause of the subtraction anomaly;
2. Identifies conditions where the accuracy of the SASSI solution may degrade;
3. Proposes an initial range of SSI variables to be tested;
4. Proposes an initial suite of SSI benchmark problems;
5. Makes technical presentations at project meetings;
6. Coordinates technical activities with the PPRT and TI;
7. Prepares engineering calculations of analyses of test problems or analytic or alternate numerical solution methods to establish benchmark solutions for each test problem;
8. Performs sensitivity studies to identify significant issues and sources of uncertainty and to establish valid ranges of input values;
9. Prepares SASSI2000 V1.0 input for benchmark problems and documents results in a technical report;
10. Develops comparisons of SDE-SASSI V2.0 results to the benchmark solutions and documents results in a technical report;
11. Prepares technical report(s);
12. Responds to PPRT and TI review comments; and
13. Prepares the SASSI guidance document and responds to PPRT and TI review comments.

Regulators and Government Oversight Agencies

The Regulators and Government Oversight Agencies (GOAs), in the context of this project, are those entities that are in a regulatory position of the work and activities or review and recommendation oversight conducted by and for DOE and by the commercial nuclear industry. DOE is a self-regulating agency with review and recommendation oversight by the DNFSB. The organizations in this category are the DNFSB and the NRC. Specifically:

1. Regulators and GOAs are observers and may observe project meetings.
2. At the end of each project meeting day, observers may voice their comments and concerns directly to project meeting participants. Comments to be considered must be submitted, in writing, to the TI within 14 days.
3. Regulators and GOAs may provide input as to condition(s) where the accuracy of the SDE-SASSI V2.0 solution may degrade. Comments received within 14 days after the meeting will be considered in the program.
4. Regulators and GOAs may provide the TI with input on the technical adequacy of the suite of test problems. This input should include the range of SSI input parameters considered by the suite of test problems. SSI input parameters include site characteristics, building sizes, and other attributes.
5. Regulators and GOAs may provide the TI with written input on the technical adequacy of draft project reports. Written comments should be submitted to the TI within 30 days of the issuance of the draft report.

Stakeholders

The stakeholders, in the context of this project, are those entities that will ultimately use and implement the SSI guidance developed by this project, and are binned into two groups: the DOE project developers and the NRC applicants. The DOE project developers are the DOE program and project offices, including their support contractors, responsible for the civil and structural design and evaluation of DOE facilities. The NRC applicants are the engineering offices of the commercial nuclear power utilities and their consulting engineers responsible for the civil and structural design of the nuclear power plants. Specifically:

1. Stakeholders are observers and may observe project meetings.
2. At the end of each project meeting day, observers may voice their comments and concerns directly to project meeting participants. Comments to be considered must be submitted, in writing, to the TI within 14 days.
3. Stakeholders may provide the TI with input on the technical adequacy of the suite of test problems. This input should include the range of SSI input parameters considered by the suite of test problems. SSI input parameters include site characteristics, building sizes, and other attributes.
4. Stakeholders may provide the TI with written input on the technical adequacy of draft project reports. Written comments should be submitted to the TI within 30 days of the issuance of the draft report.

Practitioners

The practitioners are those individuals and software development entities whose principal professional services are to conduct SSI analyses or develop and maintain computer software to conduct SSI analyses. Specifically:

1. Practitioners are observers and may observe project meetings.
2. At the end of each project meeting day, observers may voice their comments and concerns directly to project meeting participants. Comments to be considered must be submitted, in writing, to the TI within 14 days.
3. Practitioners may provide the TI with input within 14 days after the project meetings as to condition(s) where the accuracy of the SDE-SASSI V2.0 solution may degrade.
4. Practitioners may provide the TI with input on the technical adequacy of the suite of test problems. This input should include the range of SSI input parameters considered by the suite of test problems. SSI input parameters include site characteristics, building sizes, and other attributes.
5. Practitioners may provide the TI with written input on the technical adequacy of draft project reports. Written comments should be submitted to the TI within 30 days of the issuance of the draft report.

DOE Quality Assurance Oversight

The DOE QA oversight role, by virtue of the position, has the authority and accountability to fulfill the functions described in this section. DOE QA oversight for this project is performed by Ms. Debra Sparkman, with support by other QA functions as needed. The QA oversight role is to ensure that QA requirements specified in this Plan are properly being implemented 1) during the development of the test problems and input parameters needed to demonstrate the accuracy of the SSI solutions; and 2) by the IT when performing the processes identified and generating deliverables specified in this Plan.

WORK ACTIVITIES

The major tasks and project meetings that will be implemented consist of the following:

- Develop a project plan defining the study approach and scope, team personnel, functions and communication paths, and schedule. *Completed with the November 2011 version of this Plan; updated in December 2011 and in this revision.*
- Develop a position paper documenting the cause of anomalies observed during the implementation of a modeling approach wherein the number of interaction nodes is limited to the boundary between the sides of the structure and the surrounding soils (referred to as the subtraction method).
- Develop a summary of the DOE/NRC site soil profiles and properties and identify characteristics of building structures currently in design and/or evaluation for SSI

effects, i.e., the CMRR and UPF projects. This summary will help guide the initial scope of test problems. *Contained in the Technical Work Plan.*

PPRT Initial Meeting: Describe the project and review the Project Plan.

- Initiate discussions with the PPRT to discuss the position paper documenting the cause of the Subtraction Method anomalies. Initiate discussion of the physical problems and solution process implemented in SASSI. *Completed in December 2011.*
- Develop a technical work plan that describes the physical problems to be solved at the computer program module and system levels. Define the range of parameters to be evaluated and the test problems that will be used to evaluate the SDE-SASSI V2.0 solution adequacy. *Completed with initial revision of February 7, 2012, with Revision 1 on February 19, 2012, and Revision 2 on July 2, 2012.*

Project Meeting 1: Review of Project Plan and Technical Work Plan, including a description of the set test problems and range of parameters to be evaluated. *Completed February 6-7, 2012.*

- Perform analyses (including sensitivity) of test problems, analytic or alternate numerical solution methods, to establish benchmark solutions for each test problem.
- Develop finite element models that are consistent with the SASSI finite element library and analyses methodology. Develop input files associated with each model that are consistent with the input requirements for UCB SASSI2000 V1.0. (Note that this version of the SASSI computer code has been available over the past decade, and input files that will run successfully in this version of the computer code are readily modified to run in most other implementations of SASSI).
- Develop comparisons of SDE-SASSI V2.0 computer program results to the benchmark solutions.
- Prepare an interim report that evaluates input parameters and computer code algorithms that are associated with SSI analyses performed for UPF and CMRR. *Completed with Revision A, October 8, 2012.*

Project Meeting 2: Present and discuss the benchmark solutions and the results of the draft modeling results. Present and discuss the interim report as it relates to the UPF and CMRR projects. Identify parameter ranges and algorithms to be considered in the SASSI guidance document. Develop actions to final analysis and modeling requirements. *Completed November 15-16, 2012.*

- Perform final V&V analyses of test problems, update finite element models to reflect the results of Project Meeting 2.

- Develop comparisons of SDE-SASSI V2.0 results to benchmark solutions.
- Finalize Technical Report for UPF and CMRR.
- Draft Technical Report updated to include full parameter range and algorithms to support the SASSI guidance document.
- Draft the SASSI guidance document, which will include a list of test problems that can be used to accept one of the variations of the SASSI computer program, identified limitations for use, and recommended parameter values applicable for DOE facilities.

Project Meeting 3: Present and discuss the benchmark solutions and the results of the final modeling results. Present and discuss the interim report and SASSI guidance document. Develop actions to final analysis and modeling requirements and completions to the SASSI guidance document.

- Finalize Technical Report to incorporate Project Meeting 3 results.
- Incorporate Project Meeting 3 results in the final SASSI guidance document.

SCHEDULE

The work identified in the Work Activities section of this plan has been organized and scheduled in a manner that is consistent with that depicted in Figure 1 and satisfies the needs of the project sponsors. The summary-level schedule of the work to be completed is shown in Figure 4 (see SASSI-VV-SCH-Project Schedule for the latest revision). The DOE Project Lead, with the support of the TI and CJC&A, will develop and maintain a detailed schedule of deliverable due dates. In addition, PPRT review dates, comment due dates, and revision due dates will be scheduled to be consistent with the summary-level schedule.

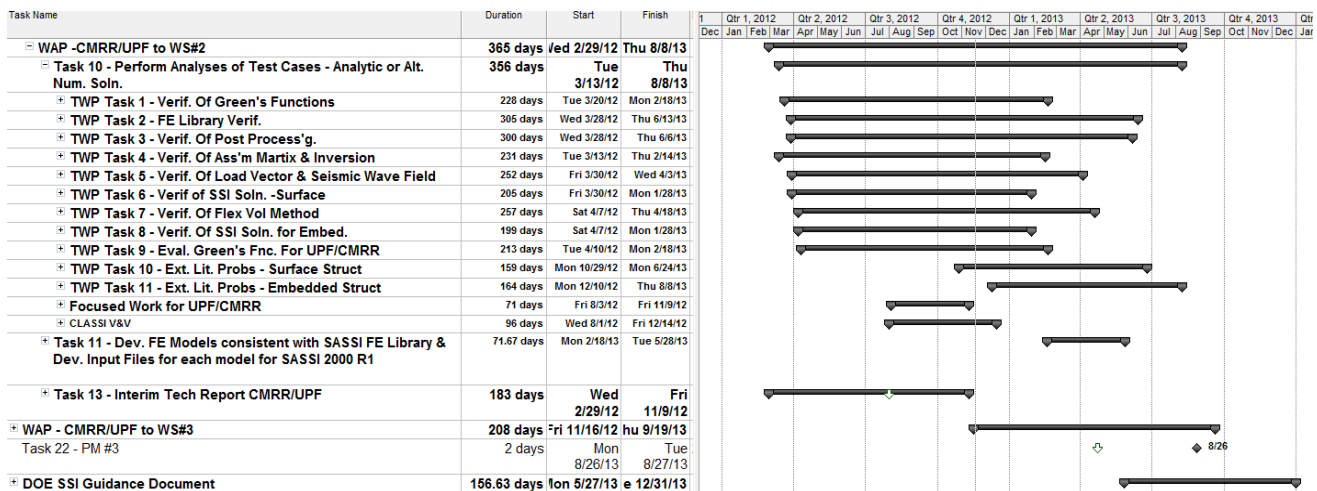

Figure 4: Summary Project Schedule

QUALITY ASSURANCE

The project quality plan (Ref. 7) identifies activities to ensure that the deliverables for this project have the appropriate level of quality. During the execution of the activities associated with this Project Plan, the processes and the products developed will be developed in accordance with the provisions of the following:

1. DOE O 414.1C, *Quality Assurance*
2. ASME NQA-1a 2009, *Quality Assurance Requirements for Nuclear Facility Applications*

The requirements of ASME V&V 10-2006, *Guide for Verification and Validation in Computational Solid Mechanics*, will be used as guidance for implementation of the work activities described in this plan.

Project-related documentation will be configuration-controlled by the DOE Technical/Project Lead and includes, but is not limited to, the following:

1. All meeting and teleconferencing minutes;
2. Project plan;
3. Project status and schedules;
4. Presentation/briefing packages;
5. PPRT correspondence;
6. IT calculations and reports;
7. Verification problem technical documentation, including computer input and output files;
8. Computer study files (input and output) from both SDE-SASSI V2.0 and alternate computations; and
9. Pertinent project-related email.

All documentation will be archived on a separate computer server that provides backup capabilities.

REFERENCES

1. G. Mertz, I. Cuesta, A. Maham, M. Costantino, *Seismic Response of Embedded Structures Using the SASSI Subtraction Method*, LA-UR-10-05302, LANL, July 2010.
2. J. Lysmer, M. Tabatabaie-Raissi, F. Tajirian, S. Vahdani, and F. Ostadan, *SASSI – A System for Analysis of Soil-Structure Interaction*, Report No. UCB/GT/81-02, Department of Civil Engineering, University of California, Berkeley, April 1981.
3. C. C. Chin, *Substructure Subtraction Method and Dynamic Analysis of Pile Foundations*, Ph.D. Dissertation, Department of Civil Engineering, University of California, Berkeley, 1998.

4. July 29, 2011, Department letter responding to the Board's letter of April 8, 2011, on the technical and software quality assurance issues of the computer program System for the Analysis of Soil-Structure Interaction (SASSI).
5. April 8, 2011, Board letter establishing a 45-day reporting requirement on issues related to the SASSI computer software code.
6. September 29, 2011 Memorandum, Michael Thompson to Kevin Smith and Theodore Sherry, *Additional Analysis to Support Resolution of Concerns with the System for Analysis of Soil-Structure Interaction (SASSI) Computer Program*.
7. D. Sparkman, *Quality Plan: Verification and Validation of SASSI*, Revision 0, SASSI-VV_PL-QualityPlan, May 2, 2012.

TECHNICAL WORK PLAN:
VERIFICATION AND VALIDATION OF SASSI

Revision 2
July 2, 2012

Plan Prepared by:

T. Houston, CJC&A

TECHNICAL WORK PLAN: VERIFICATION AND VALIDATION OF SASSI

Revision 2

July 2, 2012

Plan Prepared by:

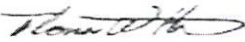

Thomas W. Houston
CJC&A

7-2-2012

Date

Plan Reviewed by:



Dr. Carl J. Costantino
CJC&A

8/12/2012

Date

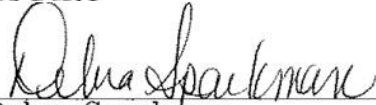

Debra Sparkman
DOE Office of the Chief of Nuclear Safety

8/14/2012

Date



Dr. James J. Johnson
Project Technical Integrator

8/7/2012

Date

Approved by:

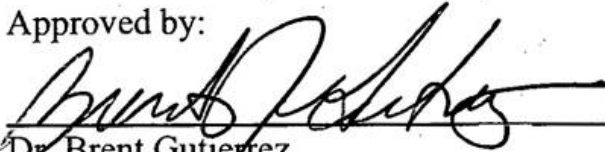

Dr. Brent Gutierrez
DOE Project Technical/Project Lead

8/28/2012

Date

Contents

Record of Revision	4
Nomenclature	7
Definitions	7
1 Introduction and Objectives of the Technical Work Plan	10
2 Description of the SASSI solution to the SSI problem	10
3 Verification Philosophy	19
4 Analysis Approach Implemented by the SASSI Computer Code	20
4.1 Analysis Approach	20
4.2 Post-Processing Analysis Results	22
4.3 Finite Element Library	22
5 Description of parameter range for UPF/CMRR	22
6 Site Profiles for DOE Sites	23
7 Summary of Nuclear Power Plant Sites	23
8 Description of Test Problem Development	23
8.1 Task 1 Verification of Green’s Function Calculations	27
8.2 Task 2 Finite Element Library Verification	30
8.3 Task 3 Verification of Post-Processing Calculations	32
8.4 Task 4 Verification of the Assembly of the Compliance Matrix and Inversion to Obtain Impedance Matrix	34
8.5 Task 5 Verification of Load Vector and Seismic Wave Field Development	35
8.6 Task 6 Verification of SSI Solution for Surface Foundations	35
8.7 Task 7 Verification of Flexible Volume Method of Substructure Deletion	36
8.8 Task 8 Verification of SSI Solution for Embedded Foundations	37
8.9 Task 9 Evaluation of Green’s Functions for UPF/CMRR Site Specific Soil Profiles . . .	37
8.10 Task 10 Extend Literature Solutions for Impedance and Seismic Response For Surface Foundations to Larger Foundation Dimensions and Higher Frequencies	37
8.11 Task 11 Extend Literature Solutions for Impedance and Seismic Response For Embedded Foundations to Larger Foundation Dimensions and Higher Frequencies	39
9 References	40
10 Figures	43

TECHNICAL WORK PLAN: VERIFICATION AND VALIDATION OF SASSI

July 2, 2012

Revision 2

CONTENTS

A	Site Soil Profiles, Seismic Input, and Building Configurations Typical for UPF	52
B	Site Soil Profiles, Seismic Input, and Building Configurations Typical for CMRR	58
C	Site Profiles for Primary DOE Sites	64
D	Site Profiles for NPP Sites	75
E	Detailed Listing of Input Parameters for Each Module	91

TECHNICAL WORK PLAN: VERIFICATION AND VALIDATION OF SASSI

July 2, 2012

Revision 2

CONTENTS

Table 1: Record of Revision

Revision Number	Pages Revised	Revision Date	Description of Revisions
Draft	Entire Document	February 1, 2012	Initial issue of draft
0	Entire Document	February 7, 2012	<ol style="list-style-type: none"> 1. Changed title from “SASSI V & V Test Problem Program: Detailed Work Plan” to Technical Work Plan: Verification & Validation of SASSI 2. Update table of contents 3. Replaced detailed work plan with technical work plan 4. Minor editing throughout document
1	Entire Document	February 19, 2012	<ol style="list-style-type: none"> 1. Add Description of Revisions Table 2. Update table of contents 3. Minor editing throughout document
2	2	July 2, 2012	<p>added signatures, comment 109</p> <p>This revision incorporates comments from WS #1 (ref. SASSI-VV-DRR-CmtResWS1-Rev00)</p> <p>The changes to Revision 1 resulted in an extensive rewrite of the document.</p>
	cover sheet general		Revised title, due to comment 110 removed overwriting of section header on title, comment 39
	10		revision due to comments 112, 113, 134, 135, 136, 26, 137, 138, 139, 140, 141
	11		revision due to comments 112, 114, 149, 115
	15		revision due to comment 116
	18		revision due to comment 114, 127
	19		revision due to comments 142, 26, 143, 144 , 27, 28, 117, 145
	20		revision due to comments 26, 146, 147, 65
	21		revision due to comment 65, 66, 149
	13		revision due to comment 67
	24		revision due to comment 26, 32. editorial change
	15		revision due to comment 65, 149
	26		revision due to comments 9, 26, 27, 34, 65, 118, 124, 128, 149. Clarified scope of Task 10 and 11.
	27		revision due to comment 22, 35, 120
	28		revision due to comment 72, 86
	32		revision due to comment 36
	33		revision due to comment 76, 78
	34		revision due to comment 149

TECHNICAL WORK PLAN: VERIFICATION AND VALIDATION OF SASSI

July 2, 2012

Revision 2

CONTENTS

Table 1: Record of Revision (Cont.)

Revision Number	Pages Revised	Revision Date	Description of Revisions
	35		revision due to comment 18, 67, 80, 149, 150, 155
	36		revision due to comment 83, 148
	37		revision due to comment 33, 85
	29 - 31		revision due to comment 9, 32, 128, 131
	34-36		revision due to comment 86
	37-42		revision due to comment 128
	43-59		revision due to comment 30, 67
	56-66		revision due to comment 68
	67-82		revision due to comment 69
	12 - 17		revision due to comments 123, 124, 125
	24		improve definition of scope of the task packages based on comment from TI
	10		add clarifier “Technical” based on comment from TI
	10		clarify description of SSI effects in objective based on comment from TI
	10		revise reference to “Program Plan” to “Project Plan” for consistency based on comment from TI
	10		revise first paragraph of Section 2 based on comment from TI
	11		revise description of SASSI versions based on comment from TI
	11		revise text for clarification based on comment from TI
	11		revise text for clarification based on comment from TI
	12		revise text for clarification based on comment from TI
	13		expanded description of POINT based on comment from TI
	14		expanded description of MATRIX based on comment from TI
	16		expanded description of MOTION based on comment from TI
	19		modified description of verification metrics based on comment from TI
	19		editorial changes based on comment from TI

TECHNICAL WORK PLAN: VERIFICATION AND VALIDATION OF SASSI

July 2, 2012

Revision 2

CONTENTS

Table 1: Record of Revision (Cont.)

Revision Number	Pages Revised	Revision Date	Description of Revisions
	20		editorial changes based on comment from TI
	32 -34		reformat section based on comment from TI
	36		modified description of Task 7 based on comment from TI
	37		modified text of Task 8 based on comment from TI
	38		modified text of Task 10 based on comment from TI
	39		modified text of Task 11 based on comment from TI
			Minor editing throughout document

Nomenclature

Definitions

Action plan Project plan[6]

Benchmark Results against which SASSI will be compared.

Benchmark solution Problem for which one or more verified solutions are available.

CMRR Chemical and Metallurgical Replacement Facility (located at Los Alamos).

Compliance matrix Dynamic flexibility matrix, complex-valued, frequency-dependent, compliance matrix is the inverse of the impedance matrix. Coefficients represent the displacement at degree-of-freedom j ($DOF(j)$) caused by a unit-amplitude harmonic force at $DOF(i)$.

Consistent mass matrix Representation of mass in the structure by distributing mass to the nodal degrees of freedom consistent with the shape functions of the element.

Control point location Location at which the forcing function or acceleration function is applied. Forcing functions and acceleration functions are time histories. Transfer functions are computed between the model DOF at which response is sought and the control point location.

Dimensionless frequency Natural frequencies (ω) normalized to a reference shear wave velocity and a reference dimension (e.g. $a_0 = \omega r/V_S$), reference shear wave velocity and reference dimensions are selected to be meaningful values for the problem being solved.

Dynamic stiffness matrix Matrix of dynamic stiffness terms used to represent the structure and excavated soil region. Stiffness and damping are represented by complex-valued and frequency-dependent terms.

Embedded foundation (structure) A structure having a portion of the foundation/structure extending into the half-space.

Excavated soil volume That region of the half-space that is removed from the model to permit insertion of the embedded portion of the foundation/structure.

Excavated zone The void region of the half-space that remains after the excavated soil volume is removed from the model.

Flexible foundation A foundation/structure, surface-founded or embedded, whose behavior is defined by explicitly modeling its dynamic stiffness, i.e., not enforcing an assumption such as rigid behavior. Interface nodes between the foundation/structure and soil/rock are connected to SASSI interaction nodes.

Flexible Volume Method (Direct Method) Method of substructuring that enforces interaction between every node in the excavated soil volume and the free-field.

TECHNICAL WORK PLAN: VERIFICATION AND VALIDATION OF SASSI

July 2, 2012

Revision 2

CONTENTS

Free-field a. The site soil/rock profile that exists prior to the removal of the excavated zone for an embedded foundation/structure; b. The free-field is defined as a location on the ground surface or in the site soil column that is sufficiently distant from the site structures to be essentially unaffected by the vibration of the site structures.

Frequency of analyses Those natural frequencies for which SSI analysis results are computed. SSI analysis results are computed directly or interpolated at these natural frequencies.

Half-space Unbounded region of either uniform or layered strata below the surface.

Hysteretic damping Frequency-independent damping associated with a force proportional to the displacement and in phase with the velocity. η

Impedance Resistance to motion when subjected to a unit-amplitude harmonic force (frequency dependent).

Interaction nodes Nodes in the SSI problem that are connected to the free-field. These nodes are also attached to the excavated soil volume.

Interpolated frequencies Those frequencies for which SSI analysis results are estimated using interpolation between computed SSI results.

Layered site That portion of the half-space (layered or uniform) located above the bottom boundary which is modeled by thin horizontal layers of infinite lateral extent.

L-wave or Love wave is a surface wave having particle motions perpendicular to the direction of propagation.

Lower boundary Boundary, fixed or transmitting, placed at the base of the SASSI representation of the half-space.

Lumped mass matrix Representation of mass in the structure by lumping mass directly on the nodal degrees of freedom of the element.

Mixed mass matrix Representation of mass in the structure by distributing mass to the nodal degrees of freedom using the average of the lumped mass and consistent mass matrices.

MODULE SASSI Sub-program. Each MODULE is executed to perform a subset of the SSI analysis problem.

Numerical Green's function Displacements of the interaction nodes to a unit-amplitude harmonic load applied on the surface of soil/rock or within the half-space. The unit-amplitude harmonic load is defined by amplitude and phase angle. The unit-amplitude harmonic load may be applied as a pressure over a defined area to avoid singularities in response.

P-wave or compressional wave is a body wave that produces particle motion in the direction of propagation – vertically propagating P-waves produce vertical particle motion.

TECHNICAL WORK PLAN: VERIFICATION AND VALIDATION OF SASSI

July 2, 2012

Revision 2

CONTENTS

R-wave or Rayleigh wave is a surface wave, including both longitudinal and transverse motions that decrease exponentially in amplitude with depth. The R-wave produces particle motion in ellipses in planes normal to the surface and parallel to the direction of propagation. Propagation speed is slightly less than that for shear waves.

Rigid foundation A foundation/structure, surface-founded or embedded, whose behavior is defined by explicitly enforcing an assumption of rigid behavior. Interface nodes between the foundation/structure and soil/rock are connected to SASSI interaction nodes.

SASSI A System of Analysis of Soil-Structure Interaction, Geotech. Engr. Div. UCB 1988

SASSI2000, V1.0 Version of SASSI updated in 1999, Geotech. Engr. Div. UCB 1999.

Scattering problem Response of excavated zone in an elastic half-space; excavated zone may be unconstrained in which case points on the boundary of the excavated zone move in a slightly correlated manner or constrained in which points on the boundary of the excavated zone move in a highly correlated manner, e.g., the assumption of rigid behavior of the boundary may be enforced, thereby, all boundary motions are correlated.

SDE SASSI V2.0 Base line version of SASSI that will be used in the SASSI V&V program. Derived from SASSI, UCB 1988 and is controlled in the CJC&A software quality assurance program. Implements algorithms consistent with SASSI2000, Rev. 1.

Slowness Velocity estimated based on the time that it takes for a plane wave to propagate through a series of individual soil layers.

Stiffness matrix Real- or complex- valued matrix of coefficients representing the force at $DOF(j)$ caused by a unit displacement at $DOF(i)$. The stiffness matrix is computed for the individual elements used to define the structure and excavated zone.

Substructure Subtraction Method The concept of the subtraction method is similar to that of the flexible volume method. However, whereas the flexible volume method keeps all excavated soil volume nodes as interaction nodes, the subtraction method recognizes that interaction occurs only at the common boundary between the excavated soil volume and structure.

Surface foundation (structure) A structure that is supported entirely on the free surface of the half-space.

S-wave or shear wave is a body wave that produces particle motion perpendicular to the direction of wave propagation – vertically propagating S-waves produce horizontal particle motion.

Transfer function Frequency-dependent, complex-valued function that relates the response of $DOF(j)$ to the unit-amplitude harmonic load or acceleration applied at the control point location.

UPF Uranium Processing Facility (located at Y12).

Verification & Validation - V&V Acronym referring to verification and validation of computer software.

1 Introduction and Objectives of the Technical Work Plan

Seismic analysis and design of high-hazard nuclear facilities requires evaluation of soil-structure interaction (SSI) effects on structure and soil response due to earthquake ground motion and other loading conditions, such as applied loads to the structure. A computer code developed by the University of California, Berkeley is widely used throughout industry to compute the effects of soil-structure interaction on the response of buildings. This computer code was made available in the 1980's and is referred to as SASSI. There are several variations of the computer program SASSI that have been and are used extensively for this purpose within the Department of Energy (DOE) complex, as well as in the commercial nuclear power industry. SASSI2000 V1.0 released by UC Berkeley is an extension of the original SASSI V1.0 developed in 1981 by UC Berkeley which added the Substructure Subtraction Method and is known to have a code base typical of most SASSI distributions in use. Recently, SASSI users [16], DNFSB, and DOE have identified software quality assurance issues with this software.

As described in "Project Plan: Verification and Validation of SASSI" [6] a technical work plan is to be developed to describe the tasks and detail of the development of a set of test problems with benchmark solutions available that can be used to demonstrate that the SASSI solution approach is valid and sufficiently accurate over the range of input parameters important to DOE and other nuclear facilities. This report describes the technical work plan considered important to the analysis of DOE facilities as well as other critical facilities. The activities described in this Technical Work Plan are performed consistent with the requirements of the "Quality Plan: Verification and Validation of SASSI" [20].

The work is divided into two Parts, wherein Part 1 is intended to verify the SASSI program capabilities for the range of parameters important to UPF and CMRR. The parameter range will be expanded during Part 2 of the project to cover the range encountered in more general applications. As the details of the work scope described in the Plan [6] are developed, this Technical Work Plan will be revised to include additional tasks. The activities (Tasks) described in this document are a subset of the activities and work schedule described in the Project Plan [6]. This subset includes providing the set of benchmark test problems associated with Part 1 of the project.

2 Description of the SASSI solution to the SSI problem

The SASSI approach to the solution of an SSI problem can be broken down into a number of basic areas, termed MODULES. The approach used to demonstrate the accuracy of the solution(s) will be to develop a set of problems that have been solved either analytically or numerically, independent of SASSI. Many of these benchmark solutions have published results in the open literature; other benchmark solutions will be generated from alternative modeling of the phenomena, i.e., independent calculation of the benchmark results in mathematical tools or alternative computer programs properly verified. For each of the basic areas or modules, the SASSI solution(s) will be compared against the benchmark solution(s). As part of the test problem development, an evaluation of the accuracy of the analytical/numerical approach to the benchmark solution and the accuracy of the approach implemented in SASSI will be performed.

TECHNICAL WORK PLAN: VERIFICATION AND VALIDATION OF SASSI

July 2, 2012

Revision 2

Reference is made to three versions of SASSI in this document:

- SASSI V1.0: developed in 1988 by UC Berkeley and distributed through November, 1999;
- SASSI2000 V1.0: released by UC Berkeley is an extension of the original SASSI V1.0 (distributed through January, 2006), which added the Substructure Subtraction Method and is known to have a code base typical of most SASSI distributions in use today.
- SDE SASSI V2.0: modified version of SASSI V1.0, which includes essentially all updates of SASSI2000 V1.0 as standard features or options; these updates include implementation of the Substructure Subtraction Method, changes to dimension statements to address a limitation in previous versions of SASSI (SASSI V1.0 and SASSI2000 V1.0) not allowing more than forty (40) soil layers to be modeled, and increases in dimension statements to permit in-core solution of larger problems. SASSI2000 V1.0 permits user specification of frequency for calculation of response spectra. SDE SASSI V2.0 does not incorporate the update.

SDE SASSI V2.0 will be the version of SASSI used in this project. Only the features contained in SDE SASSI V2.0 identical to those of SASSI2000 V1.0 will be exercised, verified, and validated in this Project. None of the additional capabilities added to SDE SASSI V2.0 will be used. This assures that the set of benchmark solutions developed in this Project will be directly applicable to users of the standard versions of SASSI. Developers/users of derivative versions of SASSI will need to demonstrate the capability of their version to match these benchmark solutions and additional benchmark solutions to test features added to their proprietary versions of SASSI for completeness.

The SASSI computer code consists of a series of MODULES that interact with each other to provide the solution to the SSI problem. These MODULES and their interactions will be evaluated and are shown schematically in Figure 1. Figure 1 is an adaptation from the SASSI2000 V1.0 User Manual. The functions of each MODULE are described below. A detailed listing of the input parameters for each of the MODULES is included in Appendix E.

HOUSE The HOUSE MODULE defines nodal degrees-of-freedom, nodal coordinates, nodal connectivity through finite element definition, and element properties. HOUSE computes complex-valued frequency independent stiffness matrices and real-valued frequency independent mass matrices for each finite element used to define the structure and excavated soil volume (where used). The module assembles the complex-valued frequency independent global stiffness matrix, K^* , and real-valued mass matrix, M , of the structure and excavated soil volume ¹. In addition, HOUSE assigns the interaction nodal degrees-of-freedom.

The functions performed by HOUSE are identified as follows:

¹Material damping is incorporated into the system through the use of the complex modulus representation of damping. For structural elements the complex-valued K^* is used to develop the element stiffness matrices and for soil elements G^* and M^* are used. K^* , G^* and M^* are the real-valued stiffness, shear modulus, and bulk modulus terms (K , G , and M) multiplied by the quantity $\left(1 - 2\xi^2 + 2i\xi\sqrt{1 - 2\xi^2}\right)$

- HOUSE 1** – define nodal locations
- HOUSE 2** – define nodal degrees-of-freedom
- HOUSE 3** – define nodal connectivity
- HOUSE 4** – define element properties
- HOUSE 5** – compute complex-valued frequency-independent stiffness and real-valued mass matrices for a) 3-D Beam Elements, b) 3-D Solid elements, c) 3-D Plate Elements, d) 2-D Plane Strain Elements, e) 3-D Spring Elements, f) Mass Elements and g) Stiffness/Mass Elements.
- HOUSE 6** – assemble the complex-valued frequency independent global stiffness matrix, K^* , of the structure and excavated soil volume
- HOUSE 7** – assemble the real-valued global mass matrix, M , of the structure and excavated soil volume
- HOUSE 8** – assigns the interaction nodal degrees-of-freedom

MOTOR The MODULE MOTOR computes values of the unit-amplitude harmonic load vector that represents the forces that are applied directly to nodal degrees-of-freedom of the structure. These values are assembled into the load vector that represents the right-hand-side (b) of the equation $Ax = b$ in the ANALYS LOADS MODULE. In this general representation, A , x , and b are frequency-dependent and complex-valued.

The functions performed by MOTOR are identified as follows:

- MOTOR 1** – define loaded nodal degrees-of-freedom
- MOTOR 2** – define amplitude and arrival time of applied load(s)
- MOTOR 3** – develop the load vector of loads applied to structure

SITE The MODULE SITE calculates the free-field mode shapes for the layered site properties. These mode shapes are used by SITE to describe the wave-field associated with the seismic environment. Additionally, the SITE module computes frequency dependent soil properties.

The functions performed by SITE are identified as follows:

- SITE 1** – define soil properties of the layered site
- SITE 2** – define the frequencies of analyses
- SITE 3** – define the type of wave-field that describes the seismic environment
- SITE 4** – calculate free-field mode shapes associated with the frequencies of analyses
- SITE 5** – calculate frequency dependent soil properties

POINT The POINT MODULE uses the soil layer property information and eigen-values and eigenvectors developed by the SITE MODULE to compute displacements caused by unit-amplitude harmonic point loads applied at the surface and layer interfaces corresponding to the depths below the surface of the

interaction nodal degrees-of-freedom.

Two-dimensional problems. The model of the layered site used in POINT for 2-D problems consists of two columns of plane-strain rectangular finite elements; two elements for each layer of the soil profile. A transmitting boundary impedance matrix is computed and connected to the outer nodal degrees-of-freedom (right and left sides) of the column of finite elements used to model the layered soil profile. The point load is applied to a center nodal degree-of-freedom of the two-column finite element model. The frequency-dependent solution is repeated for the surface location and for each layer interface associated with the depth of the interaction nodal degrees-of-freedom.

Three-dimensional problems. For 3-D problems, the model consists of a column of axisymmetric finite elements; one element representing each layer of the soil profile. Similar to the 2-D problem, an axisymmetric transmitting boundary impedance matrix is computed and connected to the outer nodal degrees-of-freedom of the axisymmetric finite element model. The point load is applied to a center nodal degree-of-freedom of the axisymmetric model. In the ensuing discussion, the column of axisymmetric elements is referred to as a “cylinder.”

Flexibility matrix. The computed displacements are used in the MODULE MATRIX to compute the flexibility matrix for the foundation.

The width (or radius) of the finite element model of the soil column is defined by a radii value specified in the POINT input file. Two choices are available for the POINT MODULE; POINT2 for two-dimensional problems and POINT3 for three-dimensional problems.

The functions performed by POINT are identified as follows:

- POINT 1** – select dimension of analysis; a) 2-D, b)3-D
- POINT 2** – define size (width or radii) of loaded region; a) strip (2-D), or b) disk (3-D)
- POINT 3** – compute complex-valued, frequency-dependent displacements at center and edge of loaded strip or disk

ANALYS The MODULE ANALYS drives three sub-MODULES; MATRIX, LOADS, and SOLVE. Each of the sub-MODULES is described below.

MATRIX MATRIX assembles the complex-valued frequency-dependent compliance matrix of the interaction nodal degrees-of-freedom (INDOF) for each frequency of analyses. The size of the resulting square compliance matrix is INDOF x INDOF. The displacements at the centerline of the cylinder (column) that are computed by POINT are used to develop the compliance matrix coefficients that are associated with interaction nodal degrees-of-freedom located within the column of finite elements (e.g. the dof located on the centerline of the finite element model of the layered soil site). Remaining terms in each column of the compliance matrix are computed using the displacements on the edge of the finite element model of the

layered soil and Equation 4.1-2 of [15].

The compliance matrix is inverted to obtain the impedance matrix for the interaction nodal degrees-of-freedom. The complex-valued frequency independent global stiffness matrix, K^* , of the structure and excavated soil volume computed by HOUSE is assembled into the global dynamic stiffness matrix, $(K^* - \omega^2 M)$, and added to the impedance matrix for the interaction nodal degrees-of-freedom to obtain the global impedance matrix of the SSI system.

The functions performed by MATRIX are identified as follows:

- MATRIX 1** – assemble the complex-valued frequency dependent compliance matrix of the interaction nodal degrees-of-freedom
- MATRIX 2** – invert compliance matrix to obtain the impedance matrix of the interaction nodal degrees-of-freedom
- MATRIX 3** – transform the complex-valued, frequency-independent global stiffness and real-valued mass matrix of the structure and excavated soil region computed by the HOUSE MODULE to the global dynamic stiffness matrix
- MATRIX 4** – assemble the global impedance matrix of the SSI system by adding the global dynamic stiffness matrix to the impedance matrix of the interaction nodal degrees-of-freedom

LOADS The MODULE LOADS assembles the load vector using the information provided by MOTOR for forces applied directly to the structural nodal degrees-of-freedom. The load vector for problems involving a seismic environment is computed for each frequency by multiplying the free-field acceleration U' by the impedance X at each interaction nodal degree-of-freedom, where U' is computed from the free-field motion for the interaction nodal degrees-of-freedom due to a unit-amplitude harmonic load applied at the control point location at each frequency of interest. The free-field motion is a function of the prescribed wave field and control point location. The control point is the location that the loading is applied either on the surface or within the soil column. For locations within the soil column the loading is an in-column motion.

The functions performed by LOADS are identified as follows:

- LOADS 1** – develop the frequency-dependent complex-valued load vector for forces applied directly to the structural nodal degrees-of-freedom
- LOADS 2** – multiply the free-field displacement U' by the impedance X at each interaction nodal degree-of-freedom and assembles the frequency dependent load vector for the seismic environment

SOLVE The MODULE SOLVE computes the complex-valued transfer functions, x , from the set of linear equations $Ax = b$, where A contains the coefficients of the global impedance matrix, and b is the complex-valued, frequency dependent load vector. The set of equations, $Ax = b$, are frequency-dependent, thus the

solution is repeated for each frequency of analysis.

As indicated by the equation $Ax = b$, the transfer function computed by SOLVE relates the displacement of nodal degrees-of-freedom of the SSI system to the applied load. For the structural load problem, this transfer function is used to obtain displacements. Velocities and accelerations for the structural load problem are developed as detailed in the MODULE MOTION description. For the seismic problem, the load vector is developed to be consistent with a unit-amplitude displacement at the control point location, thus the transfer function relates the displacement of the control point location to the displacements of the nodal degrees-of-freedom in the SSI system. The transfer functions also relate accelerations of the degrees-of-freedom of the SSI system to the acceleration applied at the control point location.

The functions performed by SOLVE are identified as follows:

- SOLVE 1** – solve the set of linear equations, $Ax = b$, to compute the complex-valued transfer functions, x ; a) in terms of total acceleration for seismic problems, b) in terms of total displacement for structure loads

COMBIN The post-processing MODULES MOTION and STRESS require a single file (file8) that contains the computed values of the results (complex-valued transfer functions). The solution of the SSI problem is generally performed for the same physical problem with different frequencies of analyses using a number of computer runs. These individual results files (transfer functions) are combined into a single file using the COMBIN MODULE which combines two results files (file8s) into a single file. When more than two results files are to be combined a series of runs must be made combining files two at a time.

The functions performed by COMBIN are identified as follows:

- COMBIN 1** – combine the results of two file8's into a single file that contains the data from the two individual files

MOTION The MODULE MOTION calculates the Fast Fourier Transform (FFT) of the input time histories at the control point location and convolves it with the transfer functions computed from SOLVE to obtain the FFT of the response quantity of interest. The inverse FFT (IFFT) is computed to transform the results into the time domain. The calculations performed by MOTION are summarized in the following steps:

1. Calculate the FFT of the input acceleration time history at the control point location (seismic problem) or input force time history (structural load problem).
2. Expand the computed values of the transfer function (the results from SOLVE) of the response quantity of interest (DOF(i)) to all frequency terms computed for the FFT of the input time history using interpolation.

TECHNICAL WORK PLAN: VERIFICATION AND VALIDATION OF SASSI

July 2, 2012

Revision 2

3. Convolve the FFT of the input time history with the expanded transfer function to obtain the FFT of the response quantity of interest (acceleration for seismic problems and displacement for structural load problems).
4. Transform the response quantity of interest into the time domain by computing the IFFT of the FFT for the response quantity of interest.

The calculation process described in steps 1 through 4 result in acceleration time histories for the seismic problem and displacement time histories for the structural load problem. For the seismic problem only acceleration time histories are provided. For the structural load problem, velocity and acceleration time histories are computed in addition to the displacement time histories resulting from implementation of steps 1 through 4. The velocity and acceleration time histories for the structural load problem are computed as follows;

- 5 Modify the values of the FFT of the response quantity of interest (computed in step 3 above) to obtain the FFT of either velocity (multiply by $i\Delta\omega(j - 1)$, where j is the frequency number) or acceleration (multiply by $(\Delta\omega(j - 1))^2$).
- 6 Transform the response quantity of interest into the time domain by computing the IFFT of the FFT for the response quantity of interest.
- 7 Extract maximum values from response time histories.

Acceleration and velocity response spectra are computed only for the seismic problem.

- 8 Calculate acceleration and velocity response spectra for the seismic problem using acceleration time histories computed from step 4 above.

The functions performed by MOTION are identified as follows:

- MOTION 1** – calculate the FFT of the input time histories (acceleration time histories for seismic motion and load functions for applied structure loads)
- MOTION 2** – obtain transfer functions (the results from SOLVE) for a) acceleration (seismic problem) or b) displacement (structural load problem)
- MOTION 3** – expand the computed values of the transfer function to develop transfer function values for all frequency terms computed for the FFT of the input motion using interpolation
- MOTION 4** – convolve the FFT of the input time history with the expanded transfer functions to compute the FFT of the response
- MOTION 5** – calculate the IFFT of the response quantity of interest to obtain the response time histories (acceleration time history for seismic problems or displacement time histories for structural load problems)
- MOTION 6** – compute velocity and acceleration time histories for the structural load problem
- MOTION 7** – compute acceleration and velocity response spectra for user selected damping values for the seismic problem
- MOTION 8** – extract maximum value of response from response time histories

TECHNICAL WORK PLAN: VERIFICATION AND VALIDATION OF SASSI

July 2, 2012

Revision 2

STRESS The MODULE STRESS calculates the Fast Fourier Transform (FFT) of the input time histories at the control point location. Response components of interest (Forces, moments and/or stresses, depending upon the element type) are calculated for each element due to the unit-amplitude harmonic load applied at the control point location for each computed frequency. The values of the response component at each computed frequency are interpolated by STRESS to compute the transfer function. This transfer function is convolved with the FFT of the input time history to obtain the FFT of the response quantity of interest. The IFFT of the FFT of the response is computed to obtain the response quantity of interest (forces, moments and/or stresses).

The functions performed by STRESS are identified as follows:

- STRESS 1** – calculate the FFT of the input time histories, identical to process described in MOTION.
- STRESS 2** – calculate response quantities of interest for each element (element force/moment/stress) due to the unit-amplitude harmonic load applied at the control point location for each computed frequency.
- STRESS 3** – expand the values of the response component at each computed frequency to develop the full transfer function using interpolation.
- STRESS 4** – convolve the expanded transfer function with the FFT of the input time history to obtain the FFT of the response quantity of interest.
- STRESS 5** – calculate the IFFT of the FFT of the response to obtain the response quantity of interest (forces, moments and/or stresses)
- STRESS 6** – extract maximum value of response from response time histories

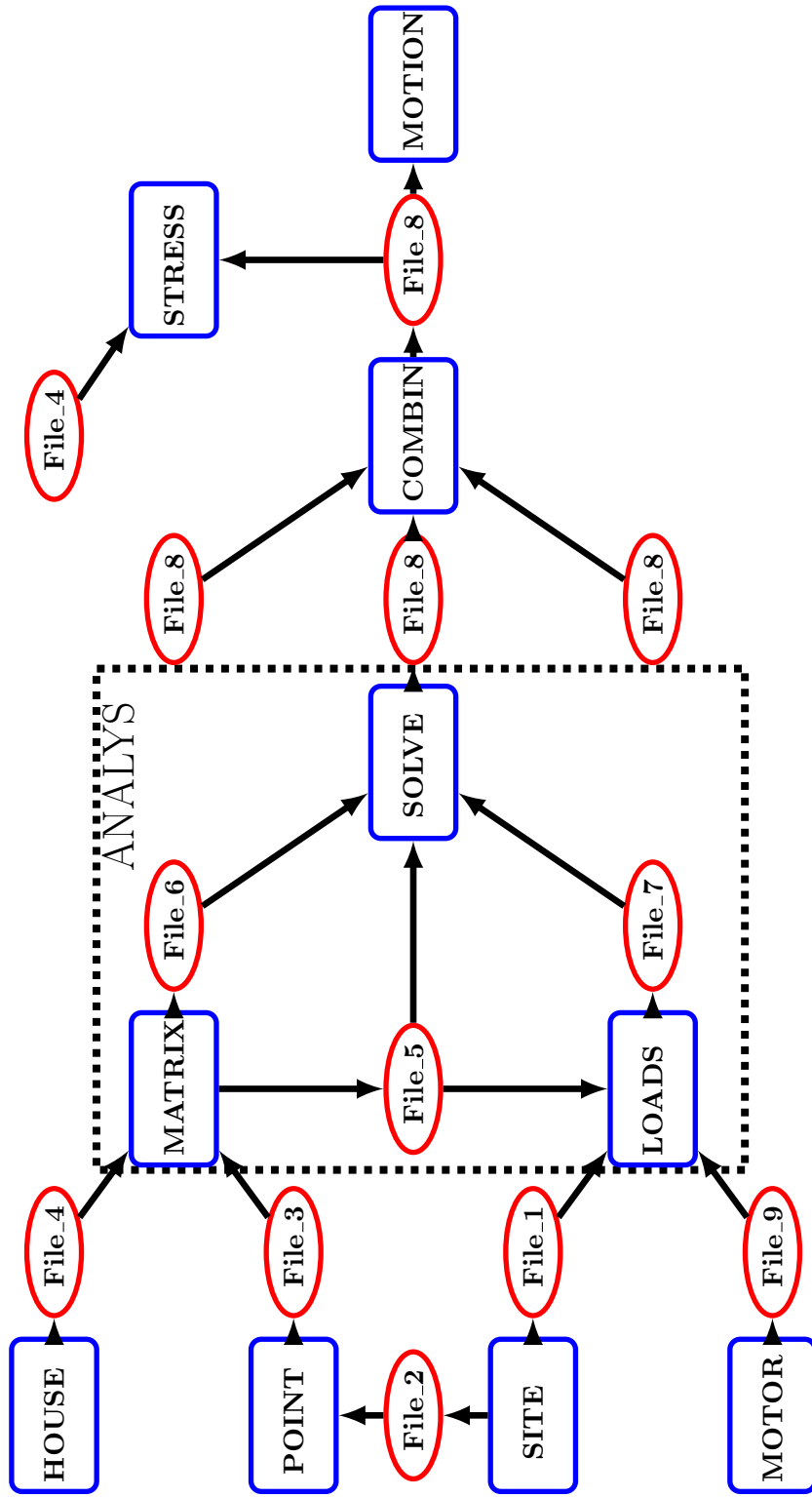

Figure 1: Layout of Computer Program SASSI

3 Verification Philosophy

The approach that will be used to develop a sufficient level of confidence in the results computed using the SASSI computer code will consist of three phases.

Phase I consists of verifying that the basic building blocks used in implementing the flexible volume method in SASSI are valid and sufficiently accurate for engineering purposes. The basic building blocks are numerical computation of the Green's function values for a surface or embedded source at observer (receiver) locations of a half-space medium and, for an embedded foundation, the method of substructure deletion to represent the half-space medium with an excavated soil volume to accommodate the embedded foundation. For a known foundation configuration, these building blocks are then used to generate the flexible-volume impedance matrix, which can be utilized to generate the rigid foundation impedance matrix by imposing the rigid foundation motion displacement constraints on the flexible-volume impedance matrix. Flexible foundation behavior is investigated using the flexible-volume impedance matrix with models of foundations assumed to behave flexibly. Phase I also consists of demonstrating the accuracy of the finite element library for later use in typical SASSI soil and structure configurations.

Solutions to the half-space Green's function problems abound in the published literature for varying assumptions as to half-space physical characteristics (uniform, layered, etc.). Solutions to the impedance and wave scattering problems for surface foundations are available in the published literature and are derivable using numerous alternative tools and approaches to SASSI. Solutions to the impedance and wave scattering problems for embedded foundations are available in the published literature for relatively simple half-space characteristics and foundations with regular shapes, e.g., circular cylinders, square-in-plan, etc. Technical Work Plan Tasks 1 through 9 address these issues. In addition, solutions for embedded foundations may be developed by alternative modeling approaches as identified later in the Technical Work Plan.

Verification metrics are "numerical" Green's functions, and derived quantities – foundation impedances and wave scattering functions for surface and embedded foundation behavior as well as solutions developed from alternative approaches (e.g. finite element, finite difference, or boundary element models).

Phase II extends the verification to more complex analysis situations for which the bases of verification are a combination of alternative solutions (available in the published literature), alternative numerical solutions performed specifically to compare with the results of SASSI, and engineering judgment of the Project Team (CJC Team (Implementing Team), Program Manager, Technical Integrator, Participatory Peer Review Team, and others, as appropriate). Examples are: flexible foundations for which there are limited published results available for surface and embedded foundations; extending the solutions obtained in Phase I to higher frequencies and larger foundation geometries; and "numerical" Green's functions for layered sites for which similar configurations do not exist in the literature. The objective is to verify the SASSI solutions with published literature and/or alternative numerical solutions supplemented by engineering judgment of the Project Team. Technical Work Plan Tasks 10 and 11 address these issues.

Verification metrics are generalized foundation impedances and responses (generalized in the sense that

for flexible foundations, comparison quantities will be displacement or acceleration shapes normalized to a peak value or other appropriate value) and in-structure dynamic responses.

Phase III addresses the more general issue of the applicability of the SASSI approach to real situations. Phase III is broader than Phases I and II in the sense of identifying real situations encountered in the engineering of actual facilities and identifying the general conditions for which SASSI is directly applicable. For more complex situations Phase III identifies the considerations or sensitivity studies that should be performed to better utilize the results of SASSI in the design of structures and in providing the input to the design and qualification of subsystems, components, and equipment.

Phase III is intended to develop qualitative guidelines as to the issues to be considered in the overall soil-structure interaction analysis process in real engineering application situations.

4 Analysis Approach Implemented by the SASSI Computer Code

The basic result from the SASSI analysis is the displacement at each nodal degree-of-freedom due to applied harmonic forces at a set of nodal degrees-of-freedom or, in the case of seismic analyses, the displacement at each nodal degree-of-freedom given a unit -amplitude harmonic displacement at a control point location in the free-field. These displacements are computed for each frequency of analysis. For the seismic problem, the acceleration at each nodal degree-of-freedom due to a unit acceleration applied at the control point location (acceleration transfer function) is equal to the displacement transfer function. The analysis approach implemented in the SASSI computer code can be summarized into a number of steps. Once the displacements are obtained, the remaining steps involve post-processing the displacement results.

4.1 Analysis Approach

The approach that will be evaluated for embedded structures in the first part of the project is the flexible volume method (direct method). Alternative approaches to modeling the excavated soil volume are not considered and must be assessed on a case-by-case basis. The analysis approach for embedded structures is similar to that for surface structures with the exception that Green's functions need to be developed over the depth of the embedment and the excavated zone must be considered. Otherwise, the analyses approach for the embedded case is consistent with the surface case. The steps in the analysis approach are:

1. Solve for the “numerical” Green's functions for each interaction nodal degree-of-freedom, where the Green's function defines the displacement at each receiver location due to a unit-amplitude harmonic load applied at a source location. For surface foundations, the Green's functions are computed for each nodal degree-of-freedom on the surface that is used to bond the structure to the free-field. For embedded foundations, the Green's functions are computed for each nodal degree-of-freedom on the free-field soil layer interfaces used to describe the excavated soil volume. The excavated soil volume describes the embedded (excavated) zone.

TECHNICAL WORK PLAN: VERIFICATION AND VALIDATION OF SASSI

July 2, 2012

Revision 2

2. Assemble a compliance matrix, $[F]$, that describes the force-displacement relationship between the interaction nodal degrees-of-freedom. Each column of the compliance matrix is computed by loading the degree-of-freedom (DOF) associated with the matrix column and computing the displacements of all the interaction nodal degrees-of-freedom.
3. Invert the compliance matrix to obtain the impedance matrix.

$$[X_f] = [F]^{-1}$$

4. For the embedded model, develop a finite element model (FEM) representation of the excavated soil volume for the foundation, $[EXC]$. This matrix is developed using 8-node brick elements for 3-D analyses and 4-node plane strain elements for 2-D analyses. The resulting matrix representation contains complex-valued, frequency-dependent dynamic stiffness terms.
5. For the embedded case, the FEM of the excavated soil volume for the foundation $[EXC]$, described in step 4, is subtracted from the impedance of the soil $[X_f]$ developed in step 3 by subtracting the complex-valued, frequency dependent impedance matrix for the excavated soil volume from the impedance matrix of the interaction nodal degrees-of-freedom.
6. Develop a finite element model (FEM) representation of the structure, $[FEM]$. This matrix is developed using a common finite element library and material damping is expressed as complex stiffness terms.
7. Combine the FEM representation of the structure with the impedance of the soil $[X_f]$ by adding the complex stiffness matrix for the structure $[FEM]$ to the impedance matrix.
8. Develop coefficients for the load vector:

[a] For loads applied directly to nodal degrees-of-freedom, either on the structure or at interaction nodal degrees-of-freedom, the load is described as a unit amplitude harmonic wave having a specified frequency.

[b] For loads developed from a seismic environment, the free-field displacements $\{u'_f\}$ for the selected wave field (e.g. SV, P, SH, Rayleigh(R), Love(L)) are computed for each frequency of analysis. These displacements are used to develop loads at each interaction nodal degree-of-freedom $\{P\} = [X_f]\{u'_f\}$. The loads at the interaction nodal degrees-of-freedom are included in the load vector associated with the seismic environment.

9. Given the assembled matrix for the SSI system developed in step 7 and the load vector developed in step 8, the system $[[FEM] + [X_f] - [EXC]]\{u\} = \{P\}$ is solved for the displacement at every nodal degree-of-freedom in the system.

The process described in Steps 1 through 9 is repeated for each frequency of analysis.

4.2 Post-Processing Analysis Results

The post-processing for both surface and embedded structures (foundations) include the steps described in the following list. Some or all of the steps may be performed depending upon the objective of the analysis.

- Combine files containing calculated transfer function values (results)
- Interpolation of transfer functions
- Compute time history of response
- Compute response spectra
- Calculate stress values

4.3 Finite Element Library

As described above, the analysis approach makes use of the finite element method to develop mathematical representations of the structure and the excavated soil volume. A finite element library is included with the SASSI program. The elements include:

- 3-D Solid Elements
- 3-D Beam Elements
- 3-D Plate Elements
- 2-D Plane Strain Elements
- 3-D Spring Elements
- Mass Elements
- Stiffness/Mass Matrix Elements

5 Description of parameter range for UPF/CMRR

The initial focus of the SASSI V & V project is to verify whether the SASSI solution approach is valid for the range of soil properties, seismic input (frequency range), and structural geometries associated with the UPF and CMRR projects. The Uranium Processing Facility (UPF) consists of a massive foundation wherein the 39 ft thick embedded foundation region is modelled with finite elements. This finite element model of the foundation is used to support finite element models of the UPF main building and several adjacent structures. The CMRR facility consists of an 83 ft tall structure that is embedded 50 ft into the soil. The SSI control point location is at the free field ground surface. The parameters (physical and dynamic analysis characteristics) that are associated with the UPF and CMRR facilities that are to be validated are;

Parameter	UPF	CMRR
Foundation plan dimension	800ft × 1000ft	342ft × 304ft
Building Footprint	Figure A-1	Figure B-1
Embedment Depth	39 ft	50 ft
Shear wave velocity profile	Figure A-3	Figure B-3
Compression wave velocity profile	Figure A-3	Figure B-4
Damping profile	Figure A-5	Figure B-5
Input response spectra	Figure A-2	Figure B-2
Structural frequency range (Hor.)	8 - 25 Hz	7.7 - 19 Hz
Structural frequency range (Vert.)	12.4 - 32 Hz	10 - 25 Hz

Note that the maximum frequency of analysis is at the frequency that the input response spectrum returns to pga or 50 Hz, whichever is less.

6 Site Profiles for DOE Sites

Site profiles for the primary DOE sites have been collected and are included in Appendix C. These profiles will aid in establishing the range of site properties that will be included in the parameters used for verification in Part 2 of the SASSI V & V Project.

7 Summary of Nuclear Power Plant Sites

Site profiles for a number of Nuclear Power Plant sites have been collected and are included in Appendix D. These profiles will be used in addition to the site profiles described in Section 6 and Appendix C to guide the range of site properties that will be included in the parameters used for verification in Part 2 of the SASSI V & V Project.

8 Description of Test Problem Development

Confidence in the overall solutions developed using the SASSI computer code will be developed using the philosophy described in Section 3. The basic building blocks for the implementation of the solution are described in the steps of the analyses approach for surface and embedded foundations (Section 4.1). The implementation of these basic steps will be checked by comparison to literature (closed-form and numerical) solutions or to solutions developed using alternative computer codes. In a similar manner, the library of finite elements available in SASSI and the various post-processing activities (described in Section 4.2) will be checked.

The execution of the Program to develop a set of test problems will be implemented as a series of tasks. Each task includes the activities needed to demonstrate the adequacy of the calculations performed by SASSI for the solution steps described in Section 4 for surface and embedded structures.

TECHNICAL WORK PLAN: VERIFICATION AND VALIDATION OF SASSI

July 2, 2012

Revision 2

Task No.	Calculation No.
1	CJC-SVV-C-001
2	CJC-SVV-C-002
3	CJC-SVV-C-003
4	CJC-SVV-C-004
5	CJC-SVV-C-005
6	CJC-SVV-C-006
7	CJC-SVV-C-007
8	CJC-SVV-C-008
9	CJC-SVV-C-009
10	CJC-SVV-C-0010
11	CJC-SVV-C-0011

The implementation of each of the tasks is described in individual calculation packages, shown above. Each of the task packages will include a complete description of the task and related verification activities. Depending upon the task, implementation will require exercising selected functionalities for the MODULES described in Section 2. The MODULE function(s) tested by each test problem will be identified within the calculation packages.

The break-down of the tasks is described as follows:

1. Task 1

Task 1 includes verifying whether the “numerical” Green’s functions computed by the SASSI program are sufficiently accurate for loads at the surface and for loads at locations embedded within the half-space, i.e.. Step 1 for surface and embedded structures (Section 4.1) The SASSI program MODULES tested in this task are highlighted in Figure 4 (blue background). Those MODULES that are executed but are incidental to the verification (red background) are also shown.

2. Task 2

Task 2 includes verifying whether the HOUSE module library of finite elements provide sufficient accuracy for the applications of SASSI. This task will verify the results that are computed using each of the finite element types in the library;

- 3-D Solid Elements
- 3-D Beam Elements
- 3-D Plate Elements
- 2-D Plane Strain Elements
- 3-D Spring Elements
- Mass Elements
- Stiffness/Mass Matrix Elements

The ability of the finite elements to provide sufficiently accurate results to model building structures is verified. The SASSI program MODULES tested in this task are highlighted in Figure 5 (blue background). Those MODULES that are executed but are incidental to the verification (red background) are also shown.

3. Task 3

Task 3 verifies whether, given the results from ANALYS (transfer functions), the post-processing calculations performed by the SASSI modules COMBIN, MOTION and STRESS provide sufficiently accurate results. The items to be verified are that the MODULE COMBIN properly combines transfer function results from individual analysis runs into a single file. This combined file will be used by the MODULES MOTION and STRESS. MOTION is used to develop time histories of response and response spectra for nodal locations. STRESS is used to develop time histories of stress from the finite element library. The implementation of the interpolation scheme used to interpolate transfer function values between specifically calculated frequencies will be checked. The calculation of the time history of responses, response spectra, and of stress in individual elements will be verified. The SASSI program MODULES tested in this task are highlighted in Figure 6 (blue background). Those MODULES that are executed but are incidental to the verification (red background) are also shown.

4. Task 4

Task 4 verifies whether, given the “numerical” Green’s function results (Task 1), the matrix is properly assembled for both surface and embedded structures. In addition, the calculation of the impedance matrix through inversion of the compliance matrix is checked. This task is associated with steps 2 and 3 described in the analysis approach for surface and embedded structures, Section 4.1. The SASSI program MODULES tested in this task are highlighted in Figure 7 (blue background). Those MODULES that are executed but are incidental to the verification (red background) are also shown.

5. Task 5

Task 5 verifies whether the load vector described in step 8 in Section 4.1 is properly developed. Loads applied directly to the structure are developed through the SASSI MODULE MOTOR. Loads applied from the seismic environment are developed by the SASSI MODULE SOLVE. SOLVE uses the free-field mode shapes computed by SITE and the impedances computed by POINT to develop the load vector for the seismic problem. part 1 of the project vertically propagating P- and SV- wave fields will be evaluated. The SASSI program MODULES tested in this task are highlighted in Figure 8 (blue background). Those MODULES that are executed but are incidental to the verification (red background) are also shown.

6. Task 6

Task 6 verifies whether the solution the foundation impedances for rigid and flexible foundations for surface structures is sufficiently accurate. This system includes the the flexible or rigid foundation modeled using finite elements and attached to the impedance matrix The foundation model is excited by the load vector. This task addresses steps 5 and 7 in Section 4.1. The SASSI program MODULES tested in this task are highlighted in Figure 9 (blue background). Those modules that are executed but are incidental to the verification (red background) are also shown.

7. Task 7

Task 7 verifies whether the approach used to model the excavated zone is sufficiently accurate. This task includes verification that the impedance matrix resulting from the calculations described in steps 4 and 5 of Section 4.1 is correct. In addition, the calculation of the displacements of the soil/structure interface is verified. The SASSI program MODULES tested in this task are highlighted in Figure 9 (blue background). Those MODULES that are executed but are incidental to the verification (red background) are also shown.

8. Task 8

Task 8 verifies whether the solution of the soil structure interaction system for embedded structures is sufficiently accurate. This system includes the the flexible or rigid foundation, modeled using finite elements, and attached to the impedance matrix. The model of the foundation is excited by the load vector. This task addresses steps 6 through 9 in Section 4.1. The SASSI program MODULES tested in this task are highlighted in Figure 9 (blue background). Those MODULES that are executed but are incidental to the verification (red background) are also shown.

9. Task 9

Task 9 extending extends the solution for Green’s functions described in Task 1 to include verifying whether the computed displacements for site profiles not directly available from literature sources are sufficiently accurate. The profiles that will be included in Part 1 of the project are those associated with the UPF and CMRR projects. The SASSI program MODULES tested in this task are highlighted in Figure 4 (blue background). Those MODULES that are executed but are incidental to the verification (red background) are also shown.

10. Task 10

Task 10 is to extend the literature solutions for surface structures, which are generally provided for relatively low (< 10) values of dimensionless frequency, $a_0 = \omega r/V_s$, to larger foundation geometries and higher frequencies. Part 1 of the project will address the plan geometries and the frequency range associated with UPF and CMRR. The SASSI program MODULES tested in this task are highlighted in Figure 9 (blue background). Those modules that are executed but are incidental to the verification (red background) are also shown.

11. Task 11

Task 11 is to extend the literature solutions for embedded structures, which are generally provided for relatively low (< 10) values of dimensionless frequency, $a_0 = \omega r/V_s$, to larger foundation geometries and higher frequencies. Part 1 of the project will address the embedded geometries and the frequency range associated with UPF and CMRR. The SASSI program MODULES tested in this task are highlighted in Figure 9 (blue background). Those MODULES that are executed but are incidental to the verification (red background) are also shown.

Sets of test problems designed to demonstrate the adequacy of the SASSI solution for each of the Tasks described above are developed. These problem sets are described in the following section.

8.1 Task 1 Verification of Green's Function Calculations

The calculation of “numerical” Green’s functions is evaluated by comparing the displacement field due to loads applied to a disk computed by the SASSI program to solutions for a uniform half-space and to solutions for a uniform layer supported by a rigid lower boundary. In addition to the uniform half-space problem, two layered half-space problems having a sixty foot thick layer of V_{s1} overlying a uniform half-space of V_{s2} are considered. The first case, a low velocity layer overlying a higher velocity layer, consists of $V_{s1} = 800\text{fps}$ and $V_{s2} = 1600\text{fps}$. A second case consisting of a higher velocity layer overlying a lower velocity layer, consists of $V_{s1} = 1600\text{fps}$ and $V_{s2} = 800\text{fps}$.

The following parameters are considered for the half-space with transmitting lower boundary and for the layer over a rigid lower boundary:

- the cylinder diameter (or width of central region for 2-D problems)
- the location of the transmitting lower boundary
- the accuracy of the absorbing boundaries
- the adequacy of $\lambda/5$ criteria ($\lambda = V_s/f$) for layer thickness and radius r
- soil damping
- aspect ratio of the cylinder diameter (or width) to layer thickness
- shear wave velocity values between 400 fps and 10,000 fps
- 2-D and 3-D solutions
- Poisson’s ratio range of 0.15 to 0.45
- layering of the half-space above the lower boundary

The individual problems shown in Tables 8.1 through 8.5, are selected to exercise a wide range of parameters when computing the “numerical” Green’s function for the soil system. These parameters are evaluated by comparing the results between various problem sets.

- Problems 1, 2 and 3 examine the sensitivity of the solution to the radius of the cylinder used in POINT and ANALYS to compute the displacement field.
- Problems 4, 5 and 6 examine the sensitivity of the solutions to the location of the top of the lower transmitting boundary.
- Problems 7, 8 and 9 provide 3-D solutions to the layered stratum supported by a rigid lower boundary.
- Problems 10 and 11 provide 2-D solutions to the layered stratum supported by a rigid lower boundary and uniform half-space.

TECHNICAL WORK PLAN: VERIFICATION AND VALIDATION OF SASSI

July 2, 2012

Revision 2

- Problems 4, 12, 13, 14 and 15 examine the adequacy of the solution over a range of Poisson's ratio between 0.15 and 0.45.
- Problems 4, 16 and 17 demonstrate that the solution is adequate over the range of material damping normally considered in SSI analyses.
- Problems 18 through 23 exercise the effect of the aspect ratio of the cylinder diameter to the layer thickness. The adequacy of the solution for these cases is checked for the transmitting bottom boundary as this is a more difficult solution than for the fixed bottom boundary condition. Problems 24 and 25 extend the velocity range considered to 10,000 fps.

The 25 problems described above consider the source located at the surface. The results computed for these problems are at the surface and at depths of 30 ft and 60 ft below the surface. For each elevation, displacements are computed at the following distances measured from the loaded nodal degree-of-freedom.

$$[x(\text{ft}), r(\text{ft})] = 0,1,2,3,4,5,6,7,8,9,10,15,20,25,50,75,100,150,200,250,300,400,500,600,700,800,900,1000.$$

Additional problems with the loaded nodal degree-of-freedom at -30 ft and -60 ft are considered as shown in Table 8.4.

- Problems 26 and 28 verify the approach implemented for 3-D cases.
- Problems 27 and 29 verify the approach for 2-D cases.

Problems 30 - 39 examine the solution for two cases of layering, while a much more complex case of layering is included in Problem 40, shown in Figures 2 and Figure 3.

The 40 benchmark solutions are used for the verification of the calculation of "numerical" Green's functions in SASSI. Benchmark solutions are developed in terms of the displacement field that describes the response of the free-field due to a unit-amplitude harmonic load applied at the surface or at a layer interface within the media. The set of benchmark problems selected provide an appropriate range of parameters that encompass the parameters associated with typical soil properties and SSI models.

Published solutions for the half-space and layer supported by a rigid boundary are available in Kausel [10], Chapters 9 and 10. Solutions computed from these references will be used to establish benchmark values for the parameters indicated in Tables 8.2 through 8.5. The results computed from the SASSI program will be compared to these benchmark values to verify the accuracy of the solution provided by the program.

Bottom Boundary	Case ID	Description
Rigid	R80	Rigid boundary at 80 ft
	R150	Rigid boundary at 150 ft
	R300	Rigid bottom at 300 ft
Half-space	H80	Half-space at 80 ft
	H150	Half-space at 150 ft
	H300	Half-space at 300 ft

TECHNICAL WORK PLAN: VERIFICATION AND VALIDATION OF SASSI

July 2, 2012

Revision 2

Table 8.2: Green's Function Test Problems - Uniform

Loaded Point	Surface; z=0ft																	
Test Problem	1	2	3	4	5	6	7	8	9	10	11	12	13	14	15	16	17	
Vs (ft/sec)	400			800														
Poisson's ratio	0.3			0.3									0.15	0.35	0.40	0.45	0.35	
Soil damping	0.5%			0.5%									0.5%			4%	15%	
R ₀ (ft)	5	2.5	1.6	5									5			5		
layer thick (ft)	5	2.5	1.6	5									5			5		
cutoff freq (Hz)	16	32	50	32									32			32		
dimension	3-D			3-D						2-D				3-D			3-D	
bottom boundary	H150			H300	H150	H80	R300	R150	R80	H300	R300	H300			H300			

Table 8.3: Green's Function Test Problems - Uniform (cont.)

Loaded Point	Surface; z=0ft									
Test Problem	18	19	20	21	22	23	24	25		
Vs (ft/sec)	1,600						3,200	10,000		
Poisson's ratio	0.3						0.3	0.3		
Soil damping	0.5%						0.5%	0.5%		
R ₀ (ft)	5			10			5	5		
layer thick (ft)	5	10	20	5	2.5	1.25	5	5		
cutoff freq (Hz)	50	32	16	32	32	32	50	50		
dimension	3-D			3-D			3-D	3-D		
bottom boundary	H80			H80			H300	H300		

Table 8.4: Green's Function Test Problems - Uniform (cont.)

Loaded Point	z=-30ft		z=-60ft	
Test Problem	26	27	28	29
Vs (ft/sec)	800		800	
Poisson's ratio	0.3		0.3	
Soil damping	0.5%		0.5%	
R ₀ (ft)	1.6		1.6	
layer thick (ft)	1.6		1.6	
cutoff freq (Hz)	50		50	
dimension	3-D	2-D	3-D	2-D
bottom boundary	H150		H150	

Table 8.5: Green's Function Test Problems - Layered

Loaded Point	Surface; z=0ft									
Test Problem	30	31	32	33	34	35	36	37	38	39
Vs _{upper} (ft/sec)	800					1,600				
Vs _{lower} (ft/sec)	1,600					800				
h _{upper} (ft)	60					60				
Poisson's ratio	0.3			0.35		0.3			0.35	
Soil damping	0.5%			4%	15%	0.5%			4%	15%
R ₀ (ft)	5					5				
layer thick(ft)	5					5				
cutoff frequency (Hz)	32					32				
dimension	3-D		2-D		3-D	3-D		2-D		3-D
bottom boundary	H300	H80	H300	H300	H300	H300	H80	H300	H300	

8.2 Task 2 Finite Element Library Verification

Finite element models are used by the SASSI program to represent structures and the excavated soil volume. The responses of interest for this task are the displacements, forces, moments, and stresses due to loads applied to the elements in a dynamic or static (dynamic at a very low frequency) manner. The resulting response will be compared to responses computed using published solutions and/or alternative finite element programs.

The baseline set of finite elements included in SASSI2000, Rev. 1 and in most distributions of SASSI include;

- 3-D Beam Elements
- 3-D Solid Elements
- 3-D Plate Elements
- 2-D Plane Strain Elements
- 3-D Spring Elements
- Mass Elements
- Stiffness/Mass Matrix Elements

The approach that will be used to evaluate the solutions computed by the finite element in the library will be to compare the results from finite element models to closed form solutions for models consisting of springs, beams, plates, plane strain elements, and solids. The solutions to the benchmark problems will be taken from literature/text sources and, where required, numerical values for comparison will be computed using Mathematica or Matlab to implement the formulæ developed in the source documents.

1. 3-D Beam Elements

Beams in the SASSI library use a lumped mass formulation, therefore the response of the beam models will be developed using two cases; 1) massless beams with masses lumped at nodal degrees-of-freedom and 2) beams with mass (density) specified.

The axial behavior of the beam elements will be evaluated using beam models that consist of axially loaded beam elements arranged to create a beam supported at one end and a mass located at the other end. The models will be excited by a harmonic load applied at the mass location and also by harmonic movement of the support. The responses will be compared to the solutions for SDOF systems included in Chopra [3], Chapter 3.

The accuracy of the beam elements for static loading will be evaluated by comparing computed responses for a horizontal cantilever beam model available from Zienkiewicz et al. [26]. The model is clamped at the right end and loaded with end shear at the left end. The problem and its analytic

solutions are described as Example 2.3 of Zienkiewicz et al. [26].

The dynamic response of the beam elements are evaluated by comparing transfer functions for a simply supported beam to computed frequencies (Beam theory) for the simply supported beam described in Example 16.3 of Zienkiewicz et al. [26]. The first three modes of the beam will be compared.

2. 3-D Solid Elements

The axial behavior of the solid elements will be evaluated using a model that consists of an axially loaded beam made of solid elements supported at one end with masses located at the other end. The models will be excited by a harmonic load applied at the mass locations and also by harmonic movement of the support. The responses will be compared to the solutions for SDOF systems included in Chopra [3], Chapter 3.

The accuracy of the solid elements for static loading will be evaluated by comparing computed responses for the same model described for the beam elements and which are available from Zienkiewicz et al. [26]. The problem and its analytic solution are described in Example 2.3 of Zienkiewicz et al. [26]. Finite element results for alternate finite element formulations for the problem are available in Zienkiewicz et al. [26], Example 6.3.

The dynamic response of the solid elements are evaluated by comparing transfer functions for a simply supported beam modeled with solid elements to computed frequencies (Beam theory) for the simply supported beam described in Example 16.3 of Zienkiewicz et al. [26]. The first three modes of the beam will be compared.

3. 3-D Plate Elements

The (membrane) behavior of the plate elements will be evaluated using plate elements to model the axial behavior of a beam. The beam is supported at one end masses located at the other end. A static load will be applied at the free end of the beam parallel to the long axis. The models will also be excited by a harmonic load applied at the mass locations and by harmonic movement of the support. The responses will be compared to the solutions for SDOF systems included in Chopra [3], Chapter 3.

For in-plane loading of plate elements the following problems will be evaluated. The accuracy of the plate elements for static loading will be evaluated by comparing computed responses for the same model described for the beam elements (available from Zienkiewicz et al. [26], Example 2.3). The problem and its analytic solution are described in Example 2.3 of Zienkiewicz et al. [26]. Finite element solutions for alternate finite element formulations for the problem are available in Zienkiewicz et al. [26], Example 6.3. The dynamic responses of the plate elements are assessed by comparing transfer functions for a simply supported beam modeled with plate elements to computed frequencies (Beam theory) for the simply supported beam described in Example 16.3 of Zienkiewicz et al. [26]. The first three modes of the beam are compared.

For out-of-plane loading of plate elements the deflections and moments for a simply supported, corner supported, and clamped square plate will be compared to solutions from Timoshenko. The model and benchmark values for this problem are included in Example 11.2 of Zienkiewicz and Taylor [25]. The dynamic response of the plate elements will be evaluated by comparison of transfer functions developed by SASSI to frequencies of response computed for the clamped rectangular plate described in Reddy [19], Example 8.11.

4. 2-D Plane Strain Elements

The solution developed by the 2-D Plane-Strain elements will be checked by comparison with 1-D wave propagation solutions wherein only horizontal movement or, alternatively, vertical movement, is permitted. Analytical solutions to the 1-D wave propagation problem are available in Kramer [12], Chapter 7. The ability of the plane strain elements to represent 2-D wave propagation solutions will be checked by using a vertical shear beam model supported and excited at the base. This model will be used to evaluate the dynamic response of the plane-strain elements. The computed responses for this model will be compared to analytic solutions from Kramer.

5. 3-D Spring Elements

Models consisting of a spring supported at one end and a mass located at the other end will be developed. The models will be excited by a harmonic load applied at the mass and also by harmonic movement of the support. The responses are compared to the solutions for SDOF systems included in Chopra [3], Chapter 3.

6. Mass Elements

The mass elements, which assign specified mass (or weight) to specified nodal DOF, are evaluated from their use in the verification of the spring, plate, beam, solid, and plane strain elements described above.

7. Stiffness/Mass Matrix Element

Stiffness/Mass Elements will be developed to replicate the response of one of the spring-mass models described above. This simple model will involve a single Stiffness/Mass Matrix Element. In addition, the response of one of the beam bending models described above will be replicated to demonstrate that coupling of Stiffness/Mass Matrix Elements is correctly implemented.

8.3 Task 3 Verification of Post-Processing Calculations

Task 3 consists of evaluating the accuracy of the various computations performed as part of post-processing. Post-processing activities include;

- combine the transfer function results from multiple ANALYS runs
- interpolate computed values of transfer functions from the ANALYS runs for all FFT frequencies
- compute time histories of response at nodal locations and select the maximum/minimum values from the time record
- compute response spectra at nodal locations given response time histories

TECHNICAL WORK PLAN: VERIFICATION AND VALIDATION OF SASSI

July 2, 2012

Revision 2

- compute strain and stress time histories from finite elements used in the finite element models and select the maximum/minimum values from the time record

1. Combining Transfer Function Results

The results (transfer functions) from the ANALYS module are saved by the SASSI program as a result file. This file contains displacement values, given a load vector, associated with each frequency of analysis calculated by the ANALYS run. For example, if frequencies $1, 2, \dots, 10$ are calculated in a single ANALYS run, then the transfer function values for all of the frequencies will be included in the results file. The COMBIN MODULE takes two ANALYS results files and combines the information into a single results file. Therefore, the MODULE COMBIN can be verified by comparing the results file for frequencies $1, 2, \dots, 10$, computed in a single ANALYS run, to the combined results file. The combined results file would be for two ANALYS runs containing, for example, separate frequencies $1, 3, 5, \dots, 9$ and $2, 4, 6, \dots, 10$. Small and very large systems of equations will be tested.

2. Interpolation

The interpolation approach used in SASSI is described in Lysmer et al. [15] wherein the interpolated transfer functions are developed using overlapping moving windows of computed values of the transfer function at five frequencies. The implementation of the interpolation will be checked by computing the interpolated results using Mathematica and comparing the results to values computed by MODULE MOTION. The transfer function for dynamic response of the out-of-plane, clamped, rectangular model described in Section 8.2 will be used to assess the interpolation function implementation.

3. Compute Time Histories

Given an input time history and a transfer function the MODULE MOTION computes the output time history. This process involves taking the Fourier Transform (FFT) of the input time history and convolving it with a transfer function. The inverse FFT of the result yields the response time history. This operation will be repeated with Mathematica and the solutions compared to the solutions provided by MOTION. In addition, the maximum and minimum calculated time history responses will be extracted from the two approaches and compared.

4. Compute Response Spectra

The MODULE MOTION uses the computed time histories to calculate response spectra at user specified damping levels. The calculation of these spectra will be verified by comparing the response spectra computed with Mathematica using the approach described by Nigam and Jennings [8] with the response spectra computed by MOTION.

5. Compute Stress

The calculation of stresses is evaluated by comparing the stresses provided in the benchmark solutions described in Task 2, or when not provided, using the displacements developed from the benchmark solutions in Task 2 to compute strains and stresses at various locations in the models. The stresses and strains recovered from the SASSI STRESS MODULE are compared to the

values developed from the benchmark solutions. The approach for each element type is described below.

[a] 3-D Solid Elements

Analytical values for stresses for the problem described by Zienkiewicz et al. [26] in Example 2.3 are provided in the source reference. These analytic values will be used as benchmarks for comparison of the responses computed using the SASSI STRESS MODULE.

[b] 3-D Beam Elements

Given the axial displacements computed for beam elements in Task 2 (e.g. Chopra [3], Chapter 3), the forces associated with the response of the axially loaded beam mass systems will be calculated and compared with the results computed using the SASSI STRESS MODULE. For bending and shear, analytical values for stresses for the problem described by Zienkiewicz et al. [26] in Example 2.3 are provided in the source reference. These analytic values will be used as benchmarks for comparison of the responses computed using the SASSI STRESS MODULE.

[c] 3-D Plate Elements

Analytical values for stresses for the problem described by Zienkiewicz et al. [26] in Example 2.3 are provided in the source reference. These analytic values will be used as benchmarks for comparison of the responses computed using the SASSI STRESS MODULE.

[d] 2-D Plane Strain Elements

Given the displacements computed for plane strain elements in Task 2, the stresses associated with the response of the shear beam systems will be calculated and compared with the results computed using the SASSI STRESS MODULE.

[e] 3-D Spring Elements

Given the displacements computed for spring elements in Task 2 (e.g. Chopra [3], Chapter 3), the forces associated with the response of the spring mass systems will be calculated and compared with the results computed using the SASSI STRESS MODULE.

[f] Mass Elements

No stress or strain components can be requested. Therefore, no verification of the output is required.

[g] Stiffness/Mass Matrix Elements

No stress or strain components can be requested. Therefore, no verification of the output is required.

8.4 Task 4 Verification of the Assembly of the Compliance Matrix and Inversion to Obtain Impedance Matrix

The compliance matrix is developed by applying a unit-amplitude harmonic load at one interaction nodal degree-of-freedom and calculating the displacement at all other interaction nodal degrees-of-freedom. This defines the values for every row of the compliance matrix in the column associated with the loaded degree-of-freedom. The process is repeated for each interaction nodal degree-of-freedom to complete the full compliance matrix. An independent definition of the compliance matrix can be developed using the Green's functions developed as described in Task 1. The compliance matrix developed by this approach will be

compared to the compliance matrix computed by SASSI.

The impedance matrix is the inversion of the compliance matrix. The compliance matrix developed using Green's function from Task 1 will be inverted and compared to the impedance matrix computed using SASSI.

Evaluation of the process of developing the compliance and impedance matrix will be performed on a 5 by 5 square grid of interaction nodes (spaced at 10 ft) and similarly for a 5 by 5 by 3 layer deep (surface layer plus 2 layers of embedded nodes) three-dimensional grid of interaction nodes. The compliance and impedance matrices will be verified for the first Fourier frequency point and for frequencies of about 10 Hz and 30 Hz.

The previous calculations constitute a direct check on the calculation process of the compliance and impedance matrices. In addition, the process is also checked, indirectly, by comparison of the impedances and responses developed in Tasks 6, 8, 10, and 11. The size of the problem is tested to verify that large systems are properly combined as well as small systems. If the matrices are computed incorrectly, the error would manifest itself in the impedances and responses that are developed for comparison to literature solutions.

8.5 Task 5 Verification of Load Vector and Seismic Wave Field Development

The load vector is developed by the MODULE MOTOR when loads are applied directly to the structure (or to individual interaction nodal degrees-of-freedom). The development of the load vector from MOTOR will be evaluated by comparing the force developed in the spring of the spring-mass model to the force applied by MOTOR. This problem will be included in Task 2.

The load vector for the case where the wave field in the free-field is defined by the earthquake problem is developed by multiplying the displacement of the interaction nodal degrees-of-freedom by the DOF impedance of the interaction nodal degree-of-freedom. The displacements in the free-field are computed by the MODULE SITE. The seismic wave field for vertically propagating normally incident P and SV waves will be computed in terms of displacements which will be compared to 1-D wave propagation solutions as described in Kramer [12], Chapter 7 and also as described in [2]. for vertically propagating P and SV waves.

8.6 Task 6 Verification of SSI Solution for Surface Foundations

The solutions for surface structures are evaluated by comparing the responses computed using SASSI to literature solutions for impedance and responses of surface structures. Many solutions are available in the literature. Solutions for 3-D rigid and flexible and 2-D strip rigid surface foundations supported on;

- uniform half-space
- layered half-space

- layer over rigid lower boundary

will be selected from the following sources.

- Luco [13], “Impedance Functions for a Rigid Foundation on a Layered Medium”
- Gazetas and Roesset [5], “Vertical Vibration of Machine Foundations”
- Wong and Luco [22], “Tables of Impedance Functions and Input Motions for Rectangular Foundations”
- Iguchi and Luco [7], “Dynamic Response of Flexible Rectangular Foundations on an Elastic Half-Space”
- Kausel and Roesset [11], “Dynamic Stiffness of Circular Foundations”
- Wong and Luco [23], “Tables of impedance functions for square foundations on layered media”

The effect of varying Poisson’s ratio on the computed SASSI results will be evaluated using comparisons provided in Kausel and Roesset [11].

8.7 Task 7 Verification of Flexible Volume Method of Substructure Deletion

The scattered motion is the sum of the components of the free-field motion and of the additional waves that are produced when the incident free-field waves encounter the excavation or inclusion. This motion considers the dynamic behavior and connectivity between adjacent regions of the inclusion (e.g. rigid or flexible) or excavated zone (free surface). The adequacy of the flexible volume method implemented in the SASSI computer code to compute the scattering effects will be verified by comparison to solutions found in the literature for responses located on the free surface of the excavated zone. SASSI models will be developed and results compared to solutions from the following sources.

- Day [4], “Finite Element Analysis of Seismic Scattering Problems”
- Zhang and Chopra [24], “Three-dimensional analysis of spatially varying ground motions around a uniform canyon in a homogeneous half-space”
- Papageorgiou and Pei [18], “A discrete wavenumber boundary element method for study of the 3-D response of 2-D scatterers”
- Luco et al. [14], “Three-dimensional response of a cylindrical canyon in a layered half-space”

In addition to the direct results that the comparisons developed in this task provide, the comparisons of SASSI results to solutions for response of embedded structure also provides an indirect check on the calculation of the displacements at the soil/structure interface because both the wave field and embedded solutions must be correctly computed to arrive at the correct total solution.

8.8 Task 8 Verification of SSI Solution for Embedded Foundations

The solutions for structures with embedded foundations and partially embedded structure elements are evaluated by comparing the responses computed using SASSI to literature solutions for impedance and responses of embedded structures. Many solutions are available in the literature. Solutions for flexible and rigid embedded foundations supported on;

- uniform half-space
- layered half-space
- layer over rigid lower boundary

will be selected from the following sources.

- Pais and Kausel [17], “On rigid foundations subjected to seismic waves”
- Gazetas and Roesset [5], “Vertical Vibration of Machine Foundations”
- Apsel and Luco [1], “Impedance Functions for Foundations Embedded in a Layered Medium: An Integral Equation Approach”
- Kausel and Roesset [11], “Dynamic Stiffness of Circular Foundations”

8.9 Task 9 Evaluation of Green’s Functions for UPF/CMRR Site Specific Soil Profiles

Green’s functions will be computed over the footprint and depth of embedment consistent with the UPF and CMRR structures. The displacement field computed by SASSI for each soil profile used in the SSI analyses will be compared to the displacement field solutions developed for the soil profiles associated with UPF and CMRR. The Green’s functions will be computed by implementing the thin layer method (TLM) [9]

8.10 Task 10 Extend Literature Solutions for Impedance and Seismic Response For Surface Foundations to Larger Foundation Dimensions and Higher Frequencies

The development of verification benchmark problems for Tasks 10 and 11 is envisioned as a sequence of steps consisting of analyses and comparisons. The results of simpler analyses will guide the modeling and evaluation of increasingly complex models. As results for each of the steps in the sequence become available the IT will consult with the TI and PPRT to incorporate input into the subsequent analyses that will be performed using models that incorporate additional complexity.

Comparison of literature to SASSI solutions for surface structures described in Task 6 will be limited to the range of dimensionless frequency provided in the literature sources. This range is generally less than the dimensionless frequency values typical for DOE and NPP structures. Task 10 includes developing and implementing an approach to extend available literature solutions to provide the basis for verification

TECHNICAL WORK PLAN: VERIFICATION AND VALIDATION OF SASSI

July 2, 2012

Revision 2

of the SASSI solution to larger values of dimensionless frequency consistent with the geometry and soil properties associated with UPF and CMRR.

The objective of Task 10 in Part 1 of the program is to extend available benchmark solutions beyond those currently available in literature solutions. To this end the evaluation process will be performed in a series of steps working from relatively simple (circular or rectangular shape supported by a uniform half-space) to more complex foundation shapes, such as irregular shapes foundations supported by layered half-space. The process will be performed for two cases; one consistent with the geometry and site properties associated with UPF and one with CMRR. Each of the problems will evaluate the response of the foundations at dimensionless frequencies corresponding to the range of frequencies between the static case (≈ 0 Hz) and 50Hz. The solutions will be developed for soil properties associated with the best estimate site profiles for UPF and CMRR.

These responses will consist of computed displacements from which rigid body impedances and, for the flexible foundation cases, frequency dependent basemat displacements and curvatures can be developed.

The initial problem for each case will evaluate circular and rectangular rigid foundations supported on the surface of a uniform half-space having a velocity consistent with slowness over a depth of the diameter of an equivalent circular foundation having an area equal to the larger of that associated with translation or with moment of inertia for rocking and twisting responses. Two approaches to developing a benchmark solution for the uniform half-space with a rigid foundation will be implemented; one based on a CLASSI solution approach (CLASSI approach) and a second based on the inversion of a flexibility matrix that is developed from Green's function responses of each nodal degree-of-freedom (GF inversion approach). The Green's functions for each case will be computed for a grid of surface nodes in the manner described in Tasks 1 and 9.

The initial solutions developed from the rigid foundation/uniform half-space will be modified to address two additional complexities; 1) the rigid rectangular foundation will be modified to reflect the irregularities in the foundation footprint by cutting out the regions of the rectangular footprint to reflect the regions having re-entrant corners and 2) the foundation will be modified from rigid to flexible. The first complexity, since it involves a rigid foundation, will be evaluated using both the CLASSI approach and the GF inversion approach. The second complexity will be evaluated using the GF inversion approach since the CLASSI approach presumes the presence of a rigid foundation.

For the flexible foundation the approach to verification will be to load the flexible plate with a uniform applied pressure and compute the frequency dependent deformation (displacement and curvature) of the plate supported by the soil. The deformations will be used to compare with deformations of a similar model computed by SASSI.

The results from these sets of problems will provide a comparison basis that will permit assessing the effect of foundation flexibility and geometric irregularity on the SSI solution for geometries associated with the UPF and CMRR structures.

The last complexity that will be considered is to develop models that can be used to define the impact of soil layering on the solutions. The benchmark solutions will be developed for a circular and rectangular rigid foundation supported on the surface of the layered half-space. In a manner similar to the uniform half-space case, two approaches to developing a benchmark solution for the layered half-space with rigid foundation will be implemented; one based on the CLASSI approach and the second based on the GF inversion approach. The Green's functions for each case will be computed for a grid of surface nodes as described in Task 9 for the best estimate soil cases.

SASSI solutions will be developed for each of the benchmark problems described above. The comparison of SASSI results to the benchmark solutions should provide sufficient data to enable the Implementor Team, TI, and PPRT to reach conclusions as to the adequacy of the SSI solution implemented in SASSI for surface foundations for the range of geometries and site soil profiles associated with the UPF and CMRR projects.

8.11 Task 11 Extend Literature Solutions for Impedance and Seismic Response For Embedded Foundations to Larger Foundation Dimensions and Higher Frequencies

Comparison of literature to SASSI solutions for embedded structures described in Task 8 will be limited to the range of dimensionless frequency provided in the literature source. This range is generally less than the dimensionless frequency values typical for DOE and NPP structures. Task 11 includes developing and implementing an approach to extend available literature solutions to provide the basis for verification of the SASSI solution to higher values of dimensionless frequency consistent with the geometry and soil properties associated with UPF and CMRR.

The objective of Task 11 is to extend the benchmark solutions developed in Task 10 to embedded problems. Similar to Task 10 the evaluation process will be performed in a series of steps working from relatively simple shaped inclusions (cylindrical and rectangular in cross-shape embedded in a uniform half-space to more complex shaped inclusions (irregular shaped geometry in cross section) embedded in a layered half-space. The process will be performed for two cases; one consistent with the geometry and site properties associated with UPF and one consistent with CMRR. Each of the problems will evaluate the response of the foundations at dimensionless frequencies corresponding to the range of frequencies between the static case (≈ 0 Hz) and 50Hz. The solutions will be developed for soil properties associated with the best estimate site profiles for UPF and CMRR.

These responses will consist of computed displacements from which rigid body impedances and, for the flexible foundation cases, frequency dependent basemat deformations (displacements and curvatures at a selection of nodal degrees-of-freedom) can be developed.

The initial problem for each case will evaluate a cylindrical and a rectangular rigid foundation embedded in a uniform half-space having a velocity consistent with slowness over a depth of the diameter of an equivalent circular foundation having an area equal to the larger of that associated with translation or

TECHNICAL WORK PLAN: VERIFICATION AND VALIDATION OF SASSI

July 2, 2012

Revision 2

REFERENCES

with moment of inertia for rocking and twisting responses. Two approaches to developing a benchmark solution for the uniform half-space with rigid foundation will be implemented; one based on a CLASSI solution approach (CLASSI approach) and a second based on the inversion of a flexibility matrix that is developed from Green's function responses of each nodal degree-of-freedom (GF inversion approach). The Green's functions for each case will be computed for a grid of surface and embedded nodes in the manner described in Tasks 1 and 9.

The initial solutions developed from the rigid foundation/uniform half-space will be modified as follows:

- The rigid rectangular foundation having irregularities in the foundation footprint will be addressed by cutting out the regions of the rectangular footprint to reflect the regions having re-entrant corners. This involves a rigid foundation and will be evaluated using the GF inversion approach.
- The adequacy of SASSI to compute the impedance matrix of an embedded flexible foundation supported by the same soil properties will be assessed using the GF inversion approach since the CLASSI approach presumes the presence of a rigid foundation. The GF will be computed for a free-field half-space soil medium with an excavation pit that accommodates the embedded foundation potentially using an approach similar to that developed by Kausel and Peek, 1982.

The results from these sets of problems, combined with the results from the surface foundation, and previous verification of the accuracy of the SASSI solution for the scattering problem provides a comparison basis that will permit assessing the effect of foundation embedment on the SSI solution for geometries associated with the UPF and CMRR structures.

The impact of soil layering on the solutions will primarily be evaluated by comparison of the effects of layering on the surface solutions and extrapolation of the effects seen to the expected response of the layered embedded case given the response of the uniform embedded cases. The development of a benchmark solution for a cylindrical and rectangular rigid foundation embedded in the layered half-space will be investigated based on either the GF inversion approach or the CLASSI approach. The Green's functions for each case will be computed for a grid of surface nodes using the methodology described in Task 9 for the best estimate soil cases.

SASSI solutions will be developed for each of the benchmark problems described above. The comparison of SASSI results to the benchmark solutions should provide sufficient data to enable the Implementor Team, Technical Integrator, and PPRT to reach conclusions as to the adequacy of the SSI solution implemented in SASSI for surface foundations for the range of geometries and site soil profiles associated with the UPF and CMRR projects.

References

- [1] Apsel, R. and Luco, J. (1987). Impedance functions for foundations embedded in a layered medium: An integral equation approach. Earthquake Engineering & Structural

TECHNICAL WORK PLAN: VERIFICATION AND VALIDATION OF SASSI

July 2, 2012

Revision 2

REFERENCES

- Dynamics, 15(2):213 – 231.
- [2] Chen, J. (1980). Analysis of Local Variations in Free Field Seismic Ground Motion. PhD thesis, University of California, Berkeley, CA, United States (USA).
- [3] Chopra, A. K. (1995). Dynamics of Structures. Prentice Hall.
- [4] Day, S. M. (1977). Finite Element Analysis of Seismic Scattering Problems. PhD thesis, University of California at San Diego, La Jolla, CA, United States (USA).
- [5] Gazetas, G. C. and Roesset, J. M. (1979). Vertical vibration of machine foundations. American Society of Civil Engineers, Journal of the Geotechnical Engineering Division, 105(12):1435 – 1454.
- [6] Gutierrez, B., Houston, T., and Costantino, C. (2011). Project Plan, Verification and Validation of SASSI.
- [7] Iguchi, M. and Luco, J. (1981). Dynamic response of flexible rectangular foundations on an elastic half-space. Earthquake Engineering & Structural Dynamics, 9(3):239 – 249.
- [8] Nigam, N. and Jennings, P. (1969). Calculation of response spectra from strong-motion earthquake records. Bulletin of the Seismological Society of America, 59:909 – 922.
- [9] Kausel, E. (1981). An explicit solution for the green functions for dynamic loads in layered media. Research Report R81-13, MIT, Cambridge, MA.
- [10] Kausel, E. (2006). Fundamental Solutions in Elastodynamics. Cambridge.
- [11] Kausel, E. and Roesset, J. M. (1975). Dynamic stiffness of circular foundations. 101(6):771 – 785.
- [12] Kramer, S. (1996). Geotechnical Earthquake Engineering. Prentice-Hall.
- [13] Luco, J. (1974). Impedance functions for a rigid foundation on a layered medium. Nuclear Engineering and Design, 31(2):204 – 217.
- [14] Luco, J., Wong, H., and De Barros, F. (1990). Three-dimensional response of a cylindrical canyon in a layered half-space. Earthquake Engineering & Structural Dynamics, 19(6):799 – 817.
- [15] Lysmer, J., Ostadan, F., and Chin, C. C. (1999b). SASSI2000, Theoretical Manual, Revision 1, A System for Analysis of Soil-Structure Interaction. University of California, Berkeley.
- [16] Mertz, et. al., LA-UR-10-05302, Seismic Response of Embedded Foundations using the SASSI Subtraction Method, Los Alamos National Laboratory, 2010.
- [17] Pais, A. L. and Kausel, E. (1989). On rigid foundations subjected to seismic waves. Earthquake Engineering & Structural Dynamics, 18(4):475 – 489.

TECHNICAL WORK PLAN: VERIFICATION AND VALIDATION OF SASSI

July 2, 2012

Revision 2

REFERENCES

- [18] Papageorgiou, A. S. and Pei, D. (1998). A discrete wavenumber boundary element method for study of the 3-d response of 2-d scatterers. Earthquake Engineering and Structural Dynamics, 27(6):619 – 638.
- [19] Reddy, J. (1993). An Introduction to The Finite Element Method. McGraw-Hill.
- [20] SASSI=VV-PL-Quality Plan, Sparkman, D. (2011). Quality Plan: Verification and Validation of SASSI, Rev. 0.
- [21] Tajirian, F. (1981). Impedance Matrices and Interpolation Techniques for 3-D Interaction Analysis by the Flexible Volume Method. PhD thesis, University of California, Berkeley, CA, United States (USA).
- [22] Wong, H. and Luco, J. (1978). Tables of impedance functions and input motions for rectangular foundations. Report - University of Southern California, Department of Civil Engineering, (78-15).
- [23] Wong, H. and Luco, J. (1985). Tables of impedance functions for square foundations on layered media. International Journal of Soil Dynamics and Earthquake Engineering, 4(2):64 – 81.
- [24] Zhang, L. and Chopra, K. (1991). Three-dimensional analysis of spatially varying ground motions around a uniform canyon in a homogeneous half-space. Earthquake Engineering and Structural Dynamics, 20(10):911 – 926.
- [25] Zienkiewicz, O. and Taylor, R. (2005). The Finite Element Method, For Solid and Structural Mechanics. Butterworth-Heinemann.
- [26] Zienkiewicz, O., Taylor, R., and Zhu, J. (2005). The Finite Element Method, Its Basis & Fundamentals. Elsevier.

TECHNICAL WORK PLAN: VERIFICATION AND VALIDATION OF SASSI

July 2, 2012

Revision 2

REFERENCES

Figures

TECHNICAL WORK PLAN: VERIFICATION AND VALIDATION OF SASSI

July 2, 2012

Revision 2

REFERENCES

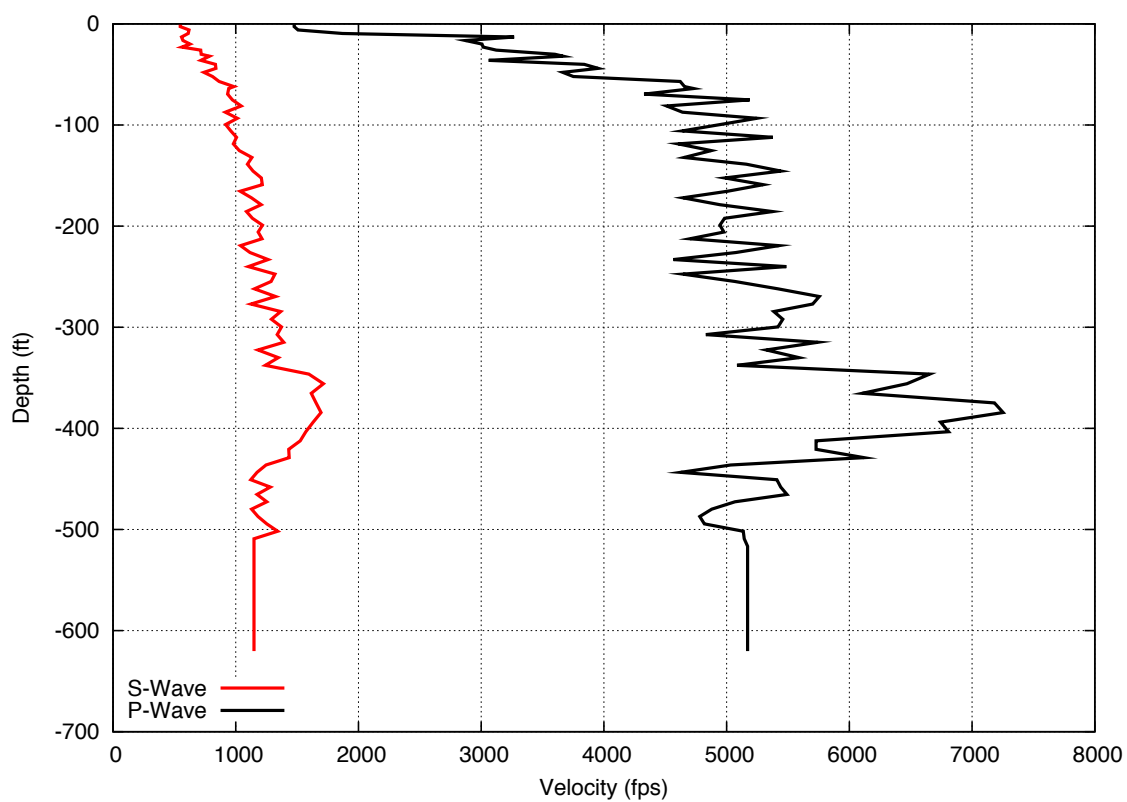

Figure 2: Problem 40 Velocity Profile

TECHNICAL WORK PLAN: VERIFICATION AND VALIDATION OF SASSI

July 2, 2012

Revision 2

REFERENCES

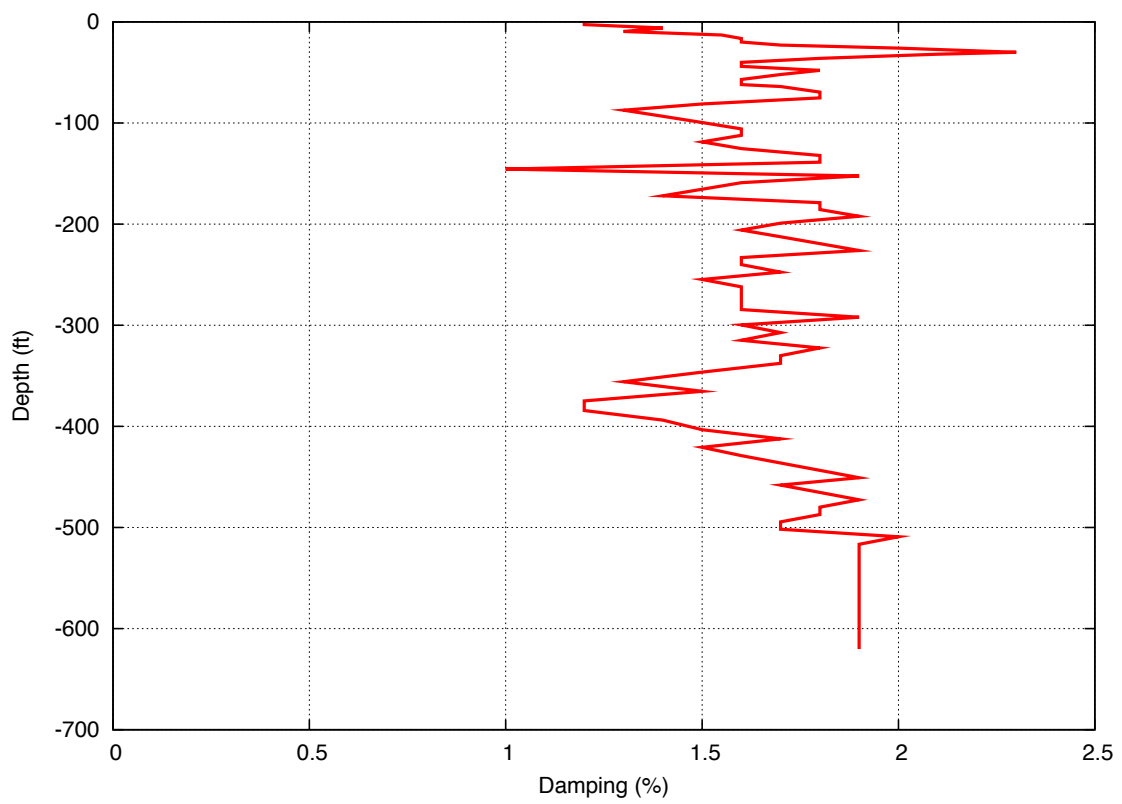

Figure 3: Problem 40 Damping Profile

TECHNICAL WORK PLAN: VERIFICATION AND VALIDATION OF SASSI

July 2, 2012

Revision 2

REFERENCES

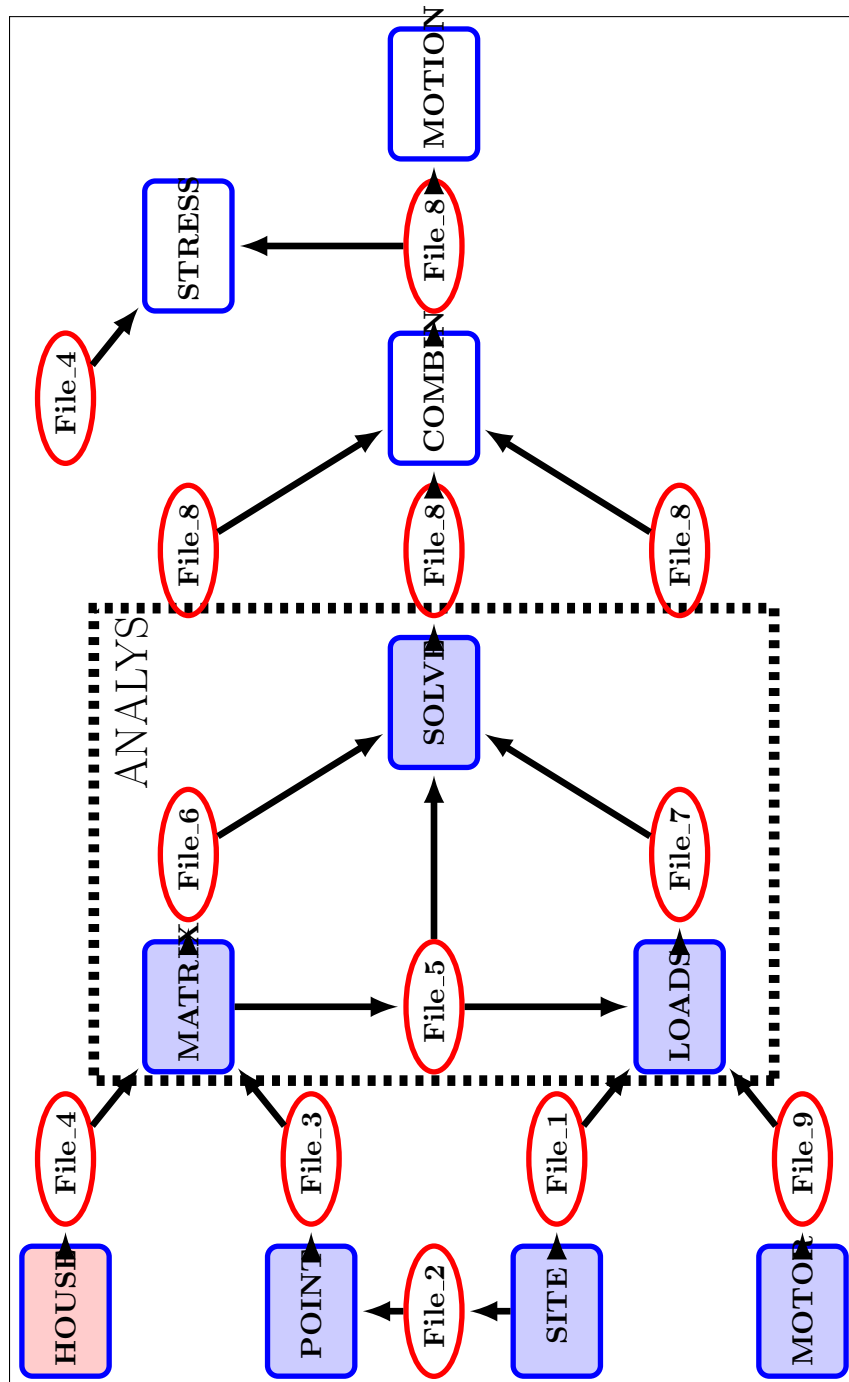

Figure 4: SASSI MODULES used for Tasks 1 and 9

TECHNICAL WORK PLAN: VERIFICATION AND VALIDATION OF SASSI

July 2, 2012

Revision 2

REFERENCES

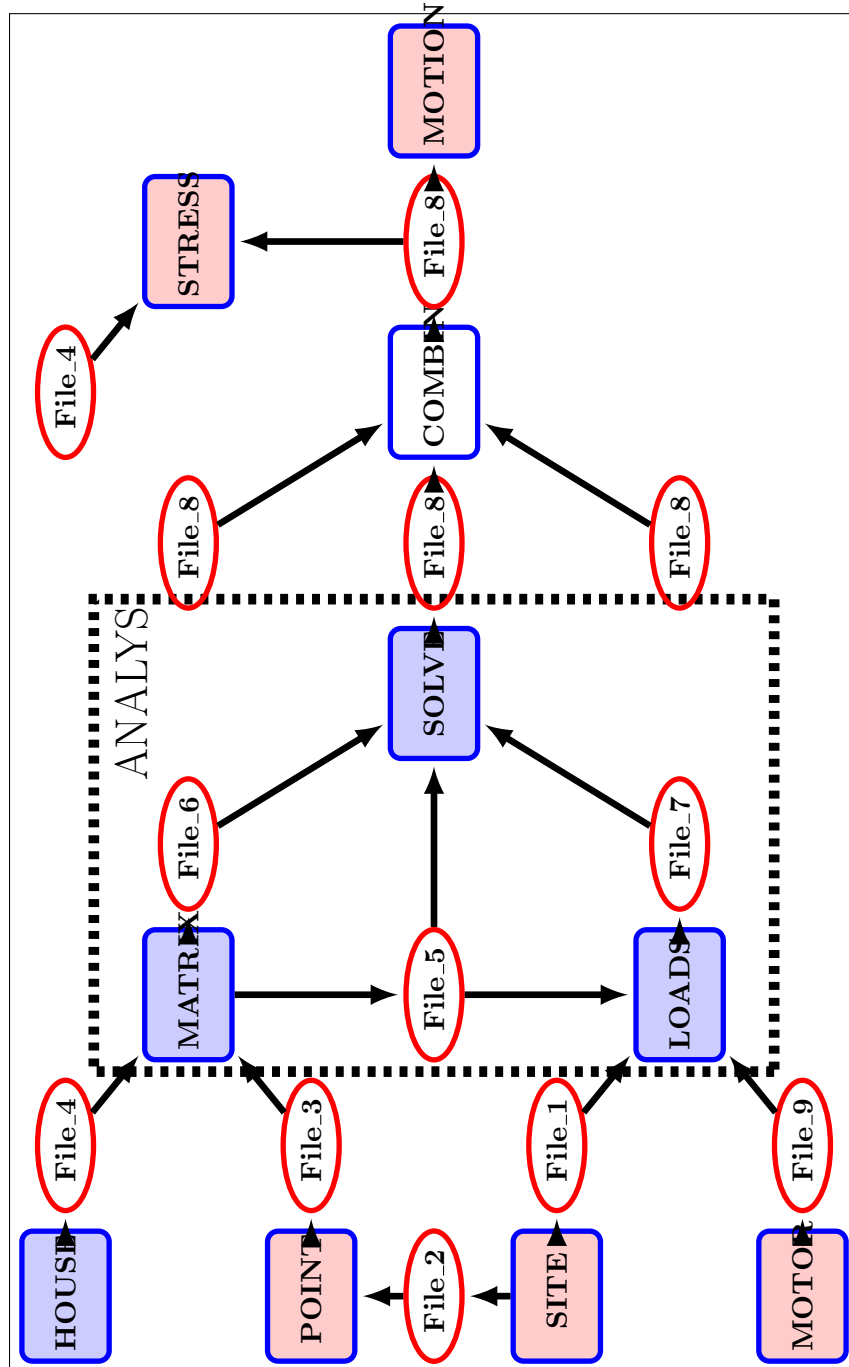

Figure 5: SASSI MODULES used for Task 2

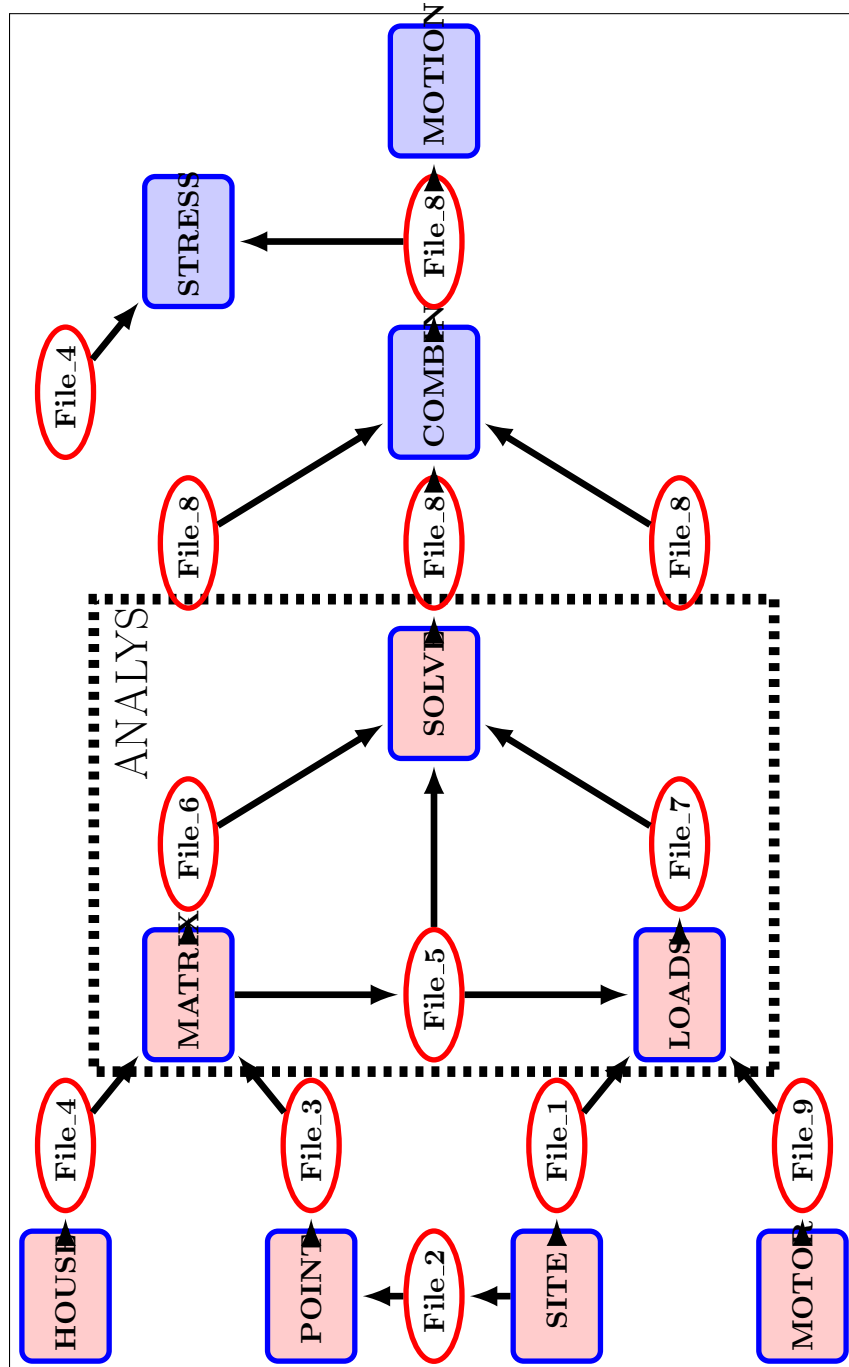

Figure 6: SASSI MODULES used for Task 3

TECHNICAL WORK PLAN: VERIFICATION AND VALIDATION OF SASSI

July 2, 2012

Revision 2

REFERENCES

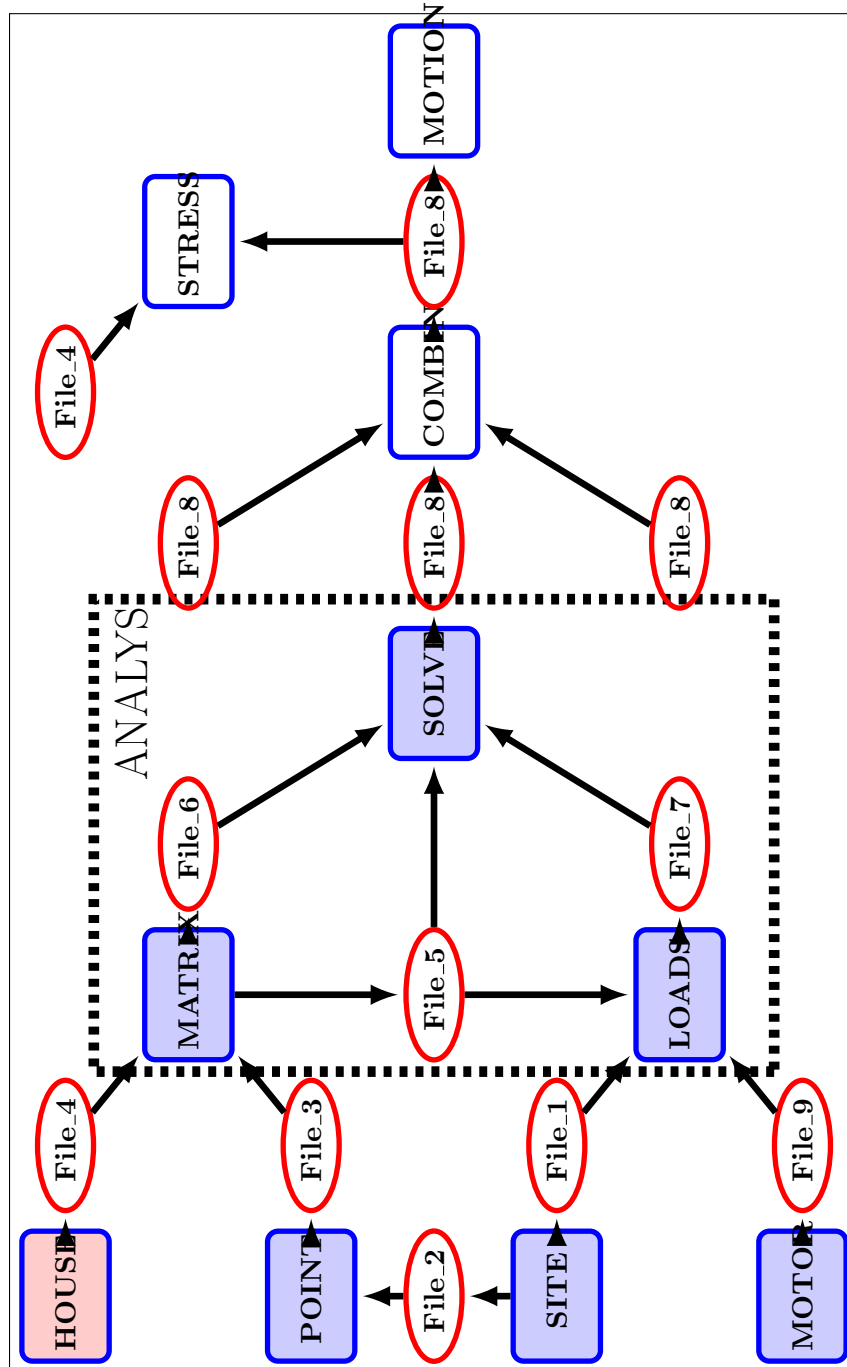

Figure 7: SASSI MODULES used for Task 4

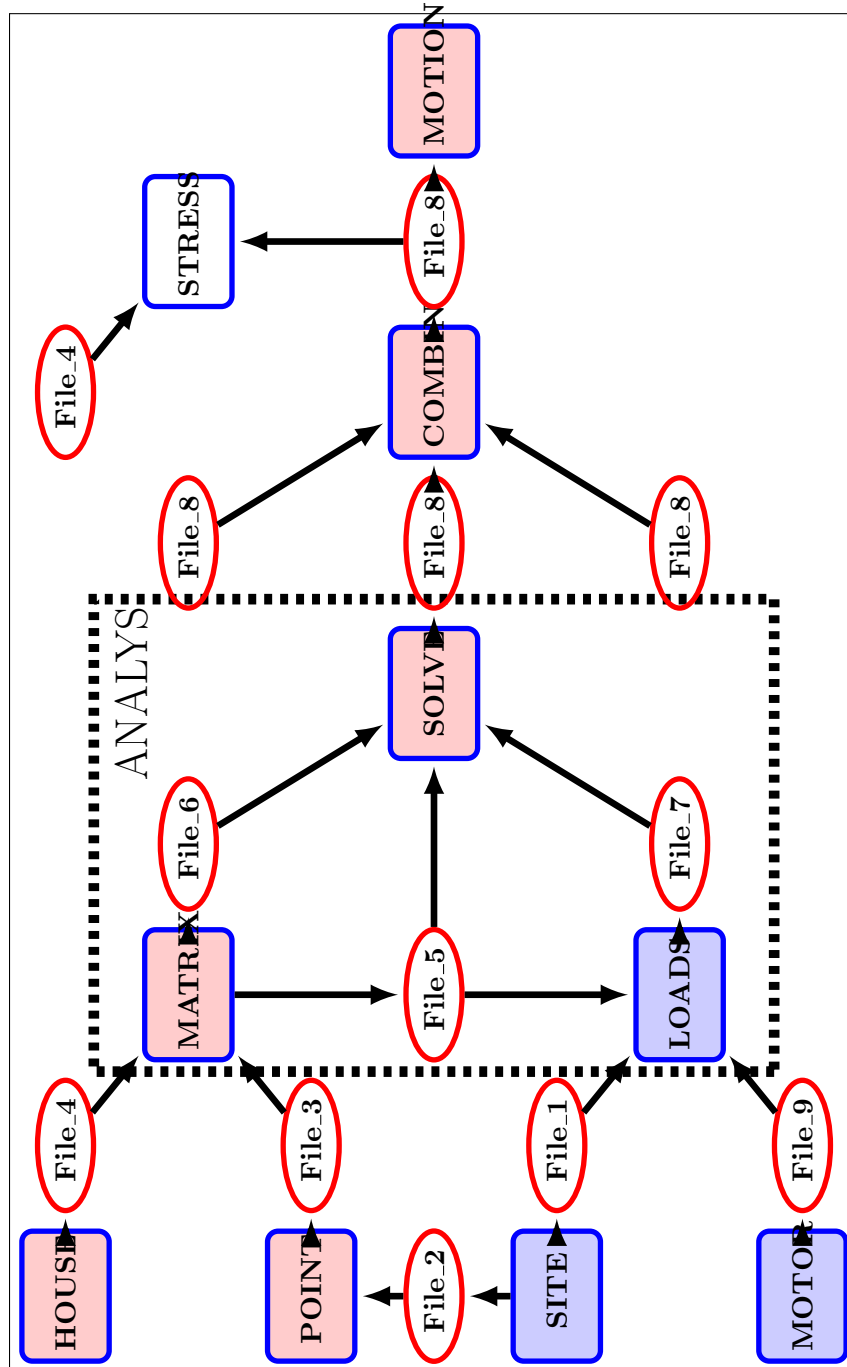

Figure 8: SASSI Computer Program flow for Task 5

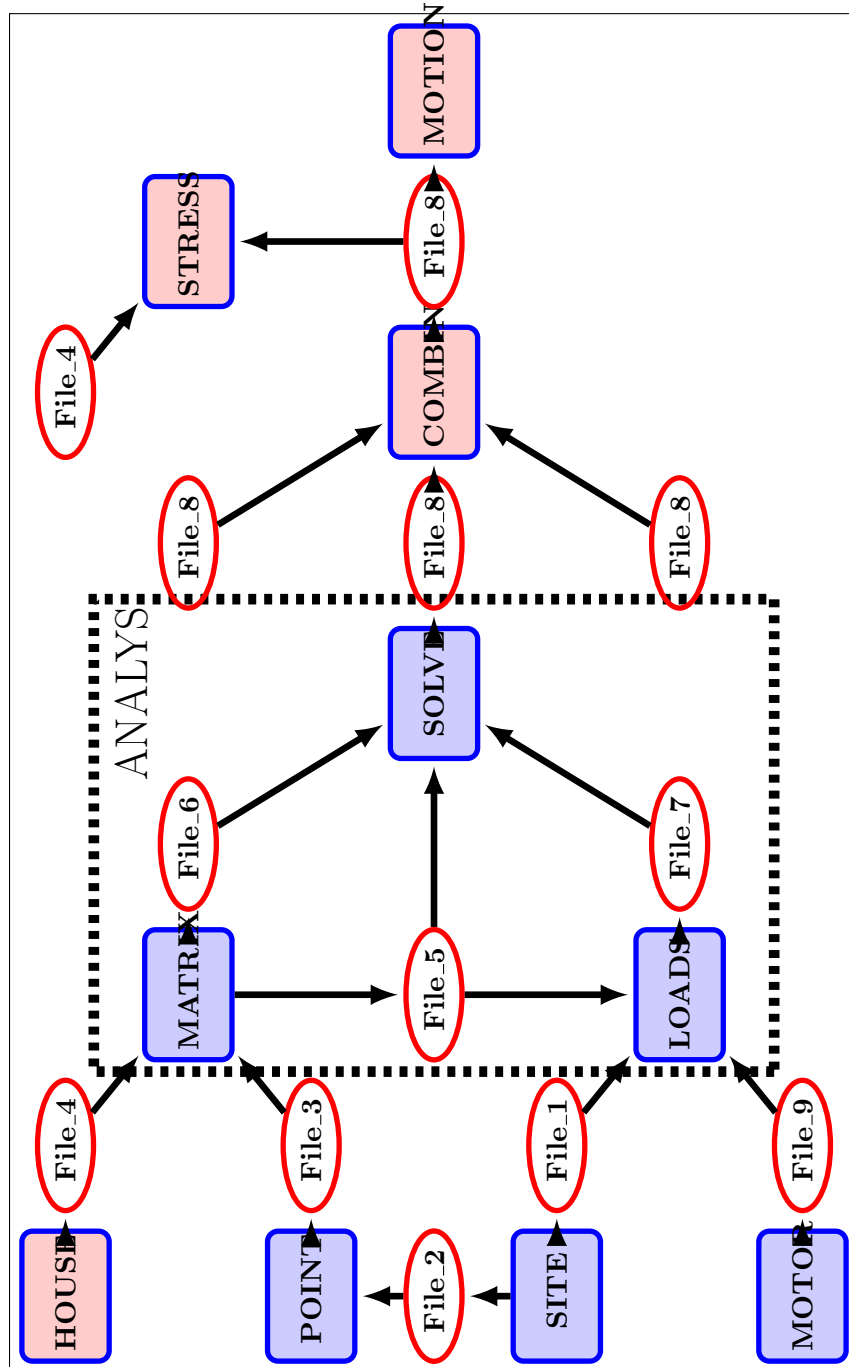

Figure 9: SASSI MODULES used for Tasks 6, 7, and 8

A Site Soil Profiles, Seismic Input, and Building Configurations Typical for UPF

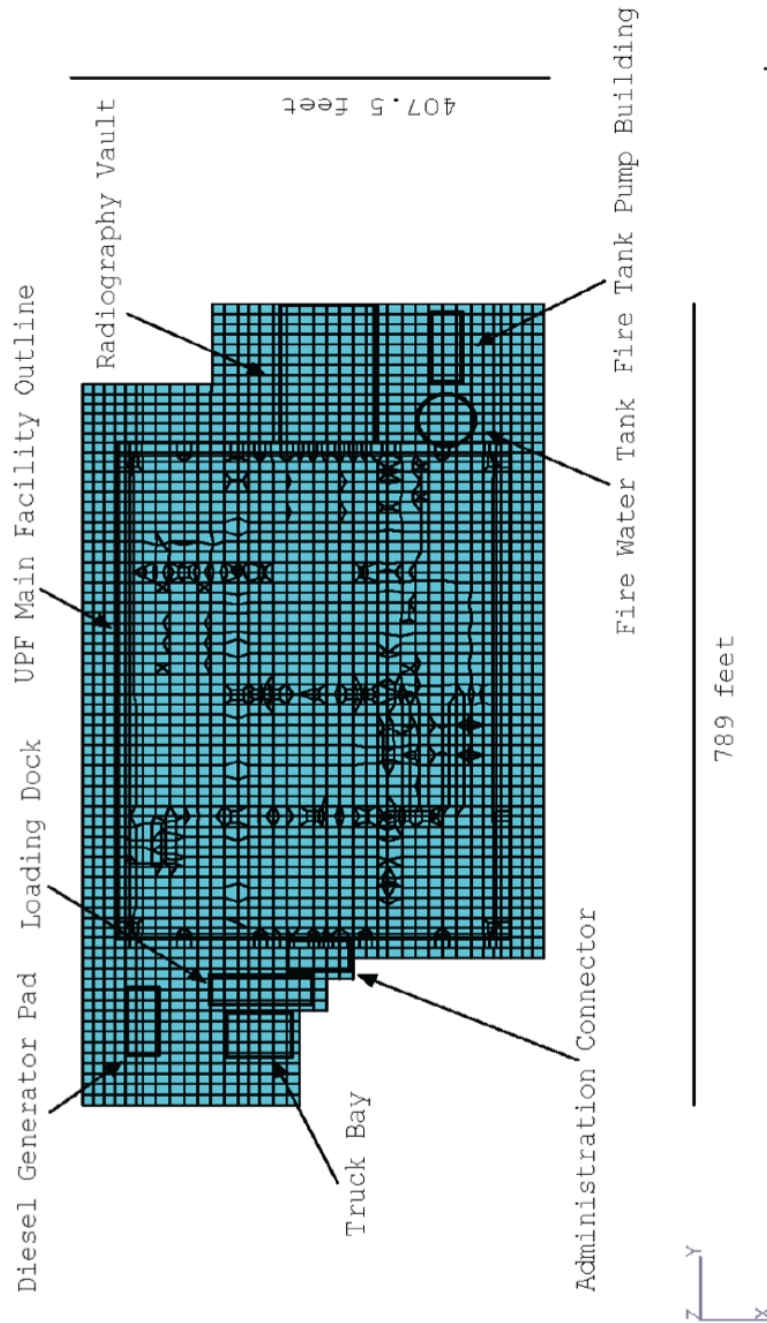

Figure A-1: Extent of Mass-Fill Concrete and Building Locations

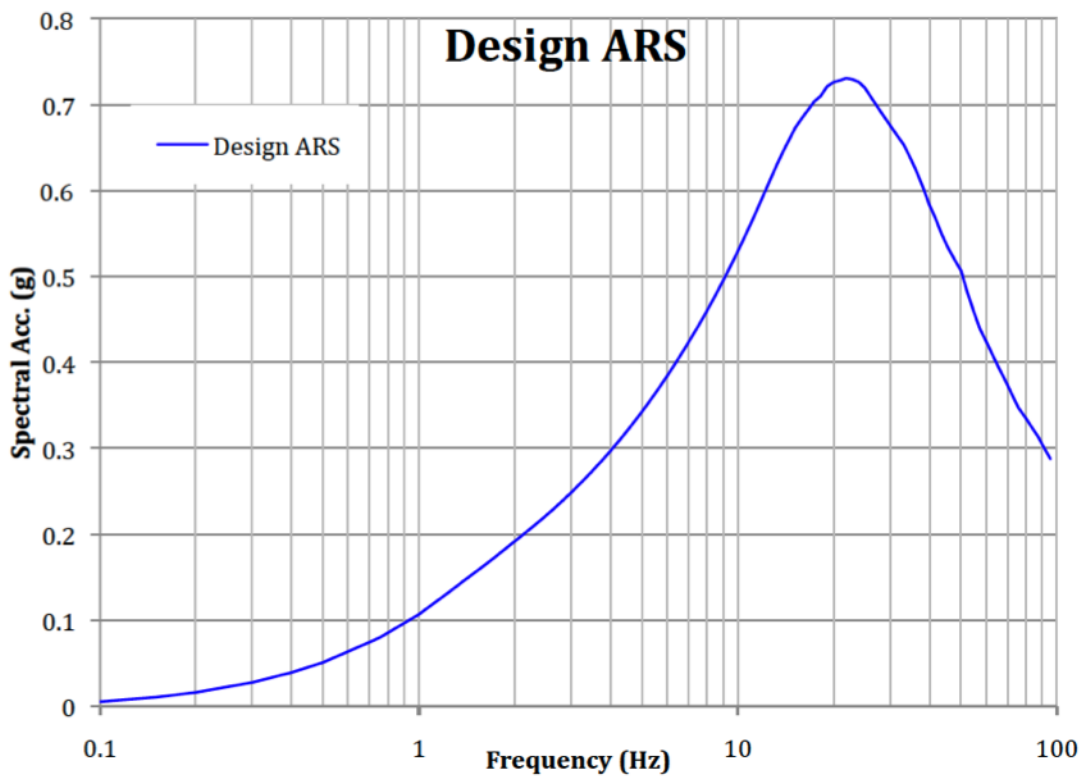

Figure 3 H and V 5% Damped Input Response Spectrum

Figure A-2: UPF Design Response Spectrum

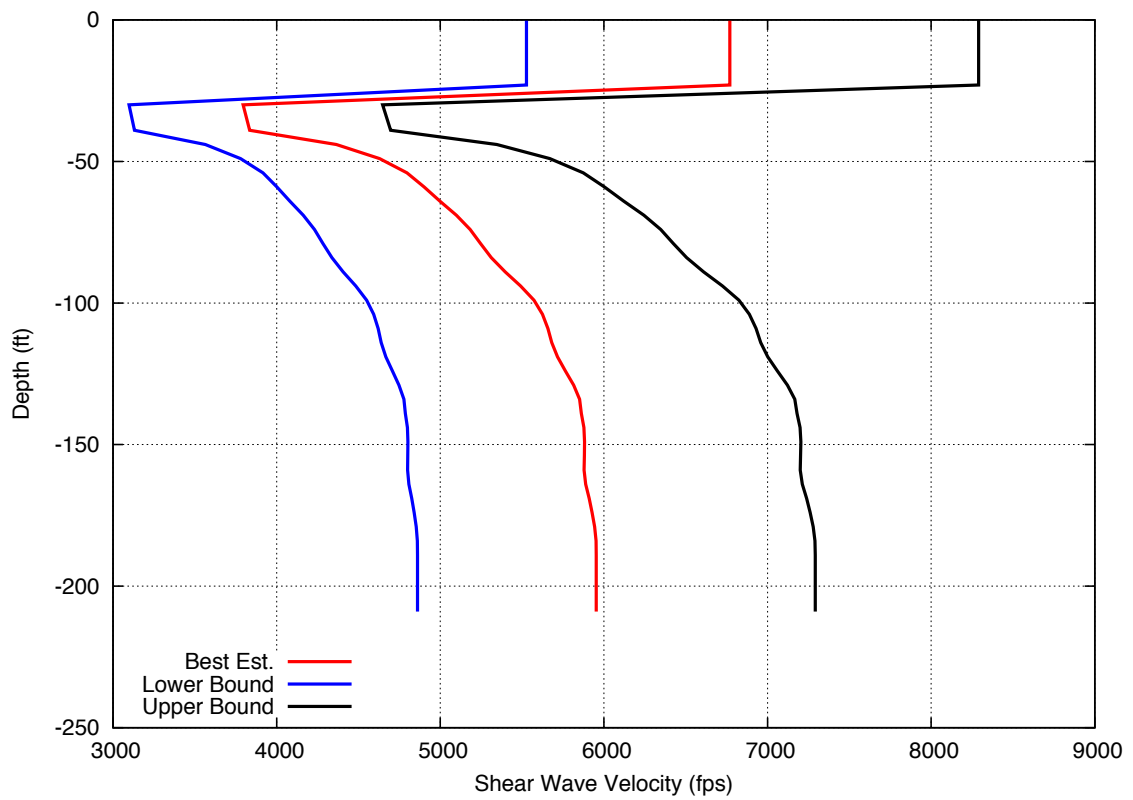

Figure A-3: UPF Site Shear Wave Velocity Profile

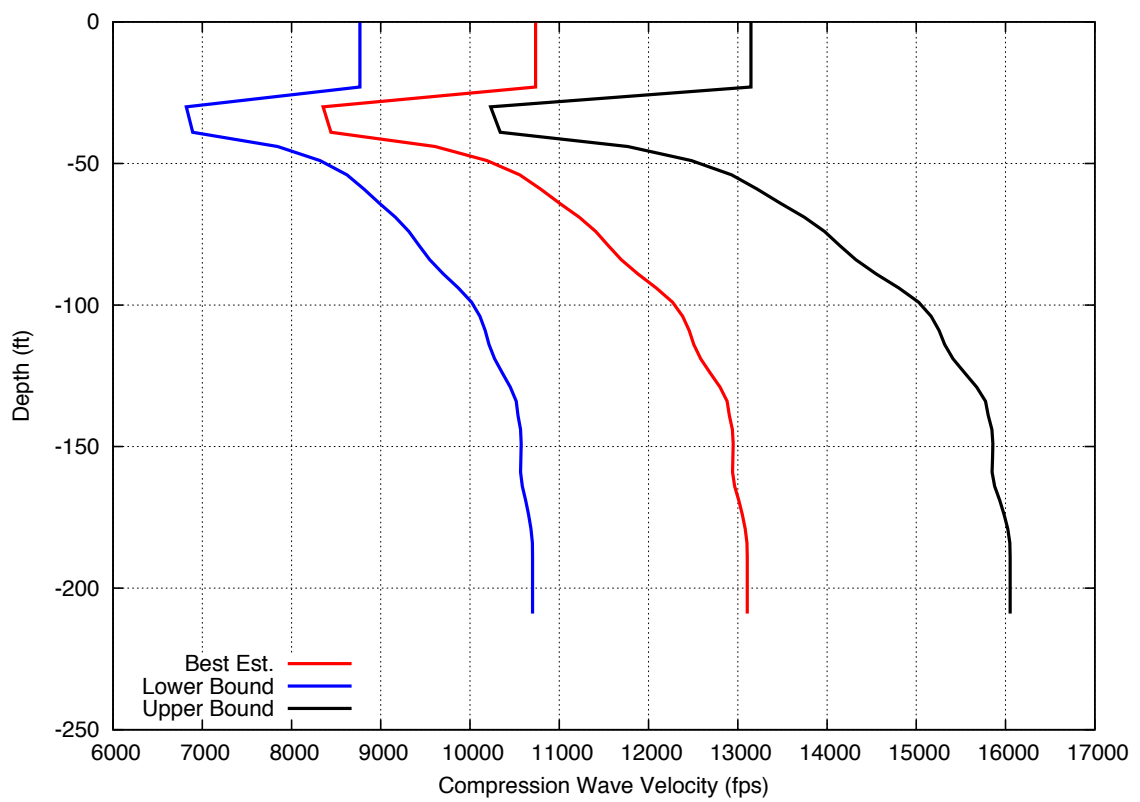

Figure A-4: UPF Site Compression Wave Velocity Profile

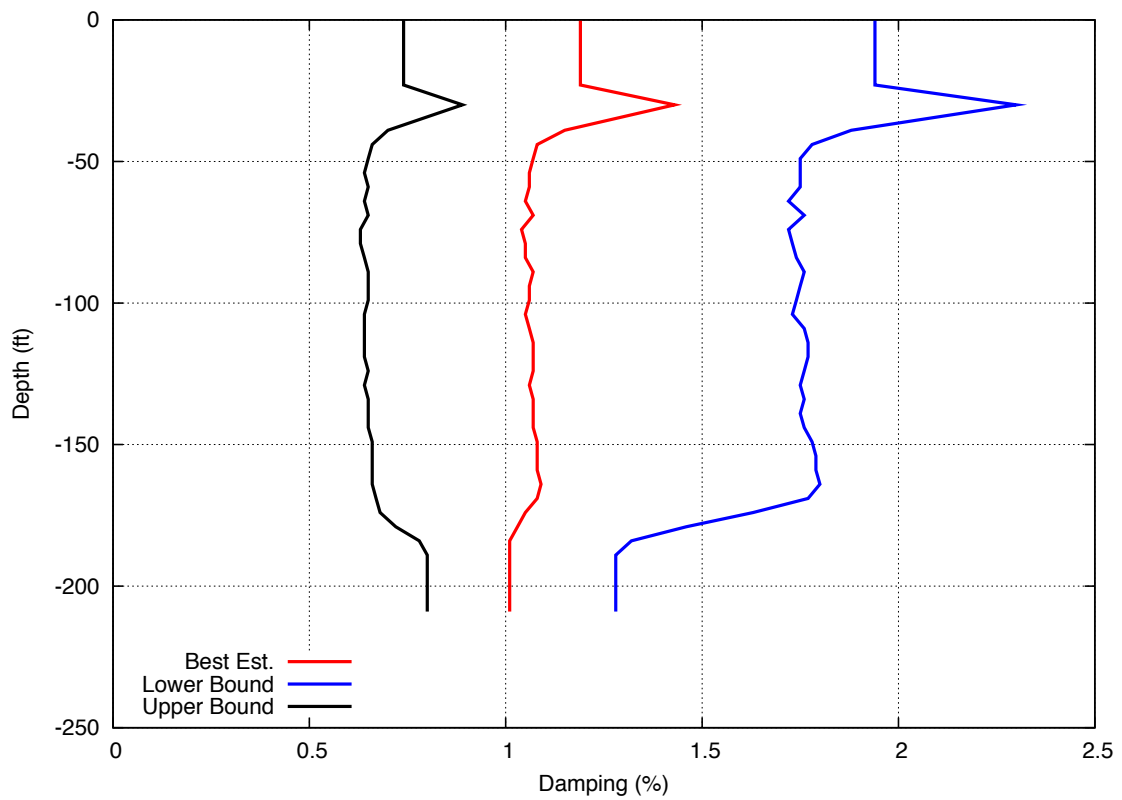

Figure A-5: UPF Site Damping Profile

B Site Soil Profiles, Seismic Input, and Building Configurations Typical for CMRR

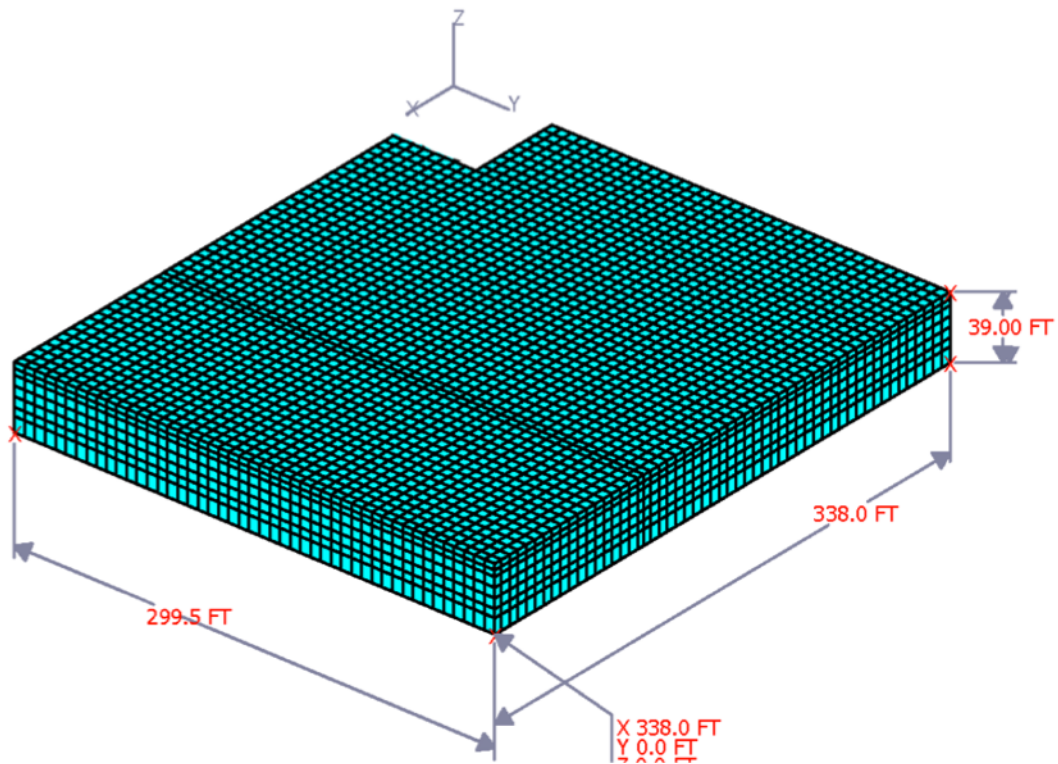

Figure B-1: CMRR Building Footprint

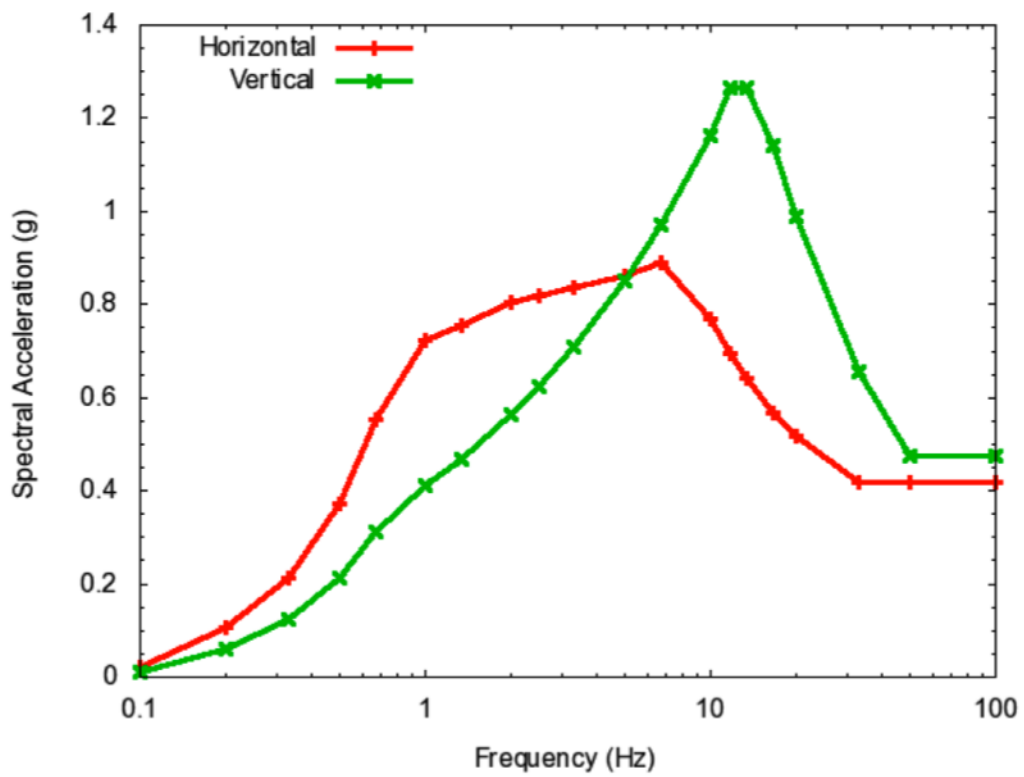

Figure B-2: CMRR Design Response Spectra

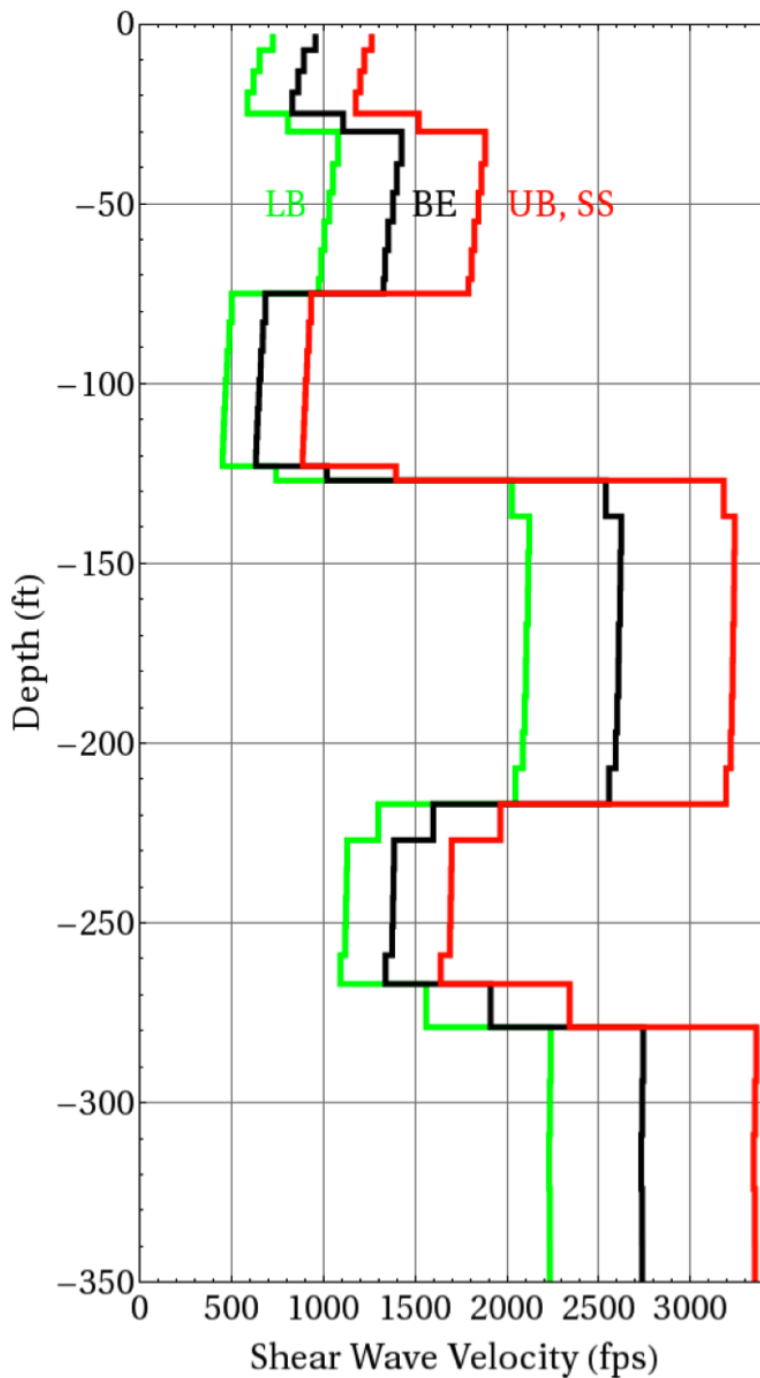

Figure B-3: CMRR Shear Wave Velocity Profile

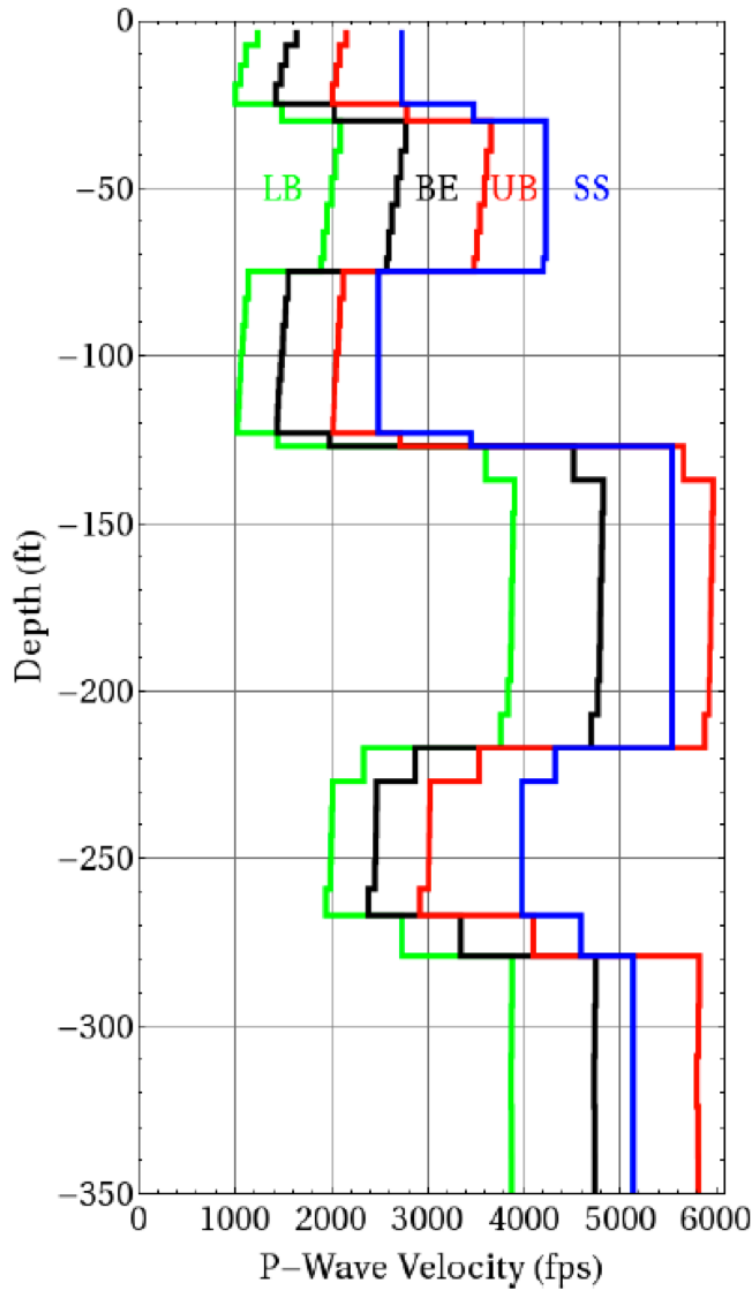

Figure B-4: CMRR P-Wave Velocity Profile

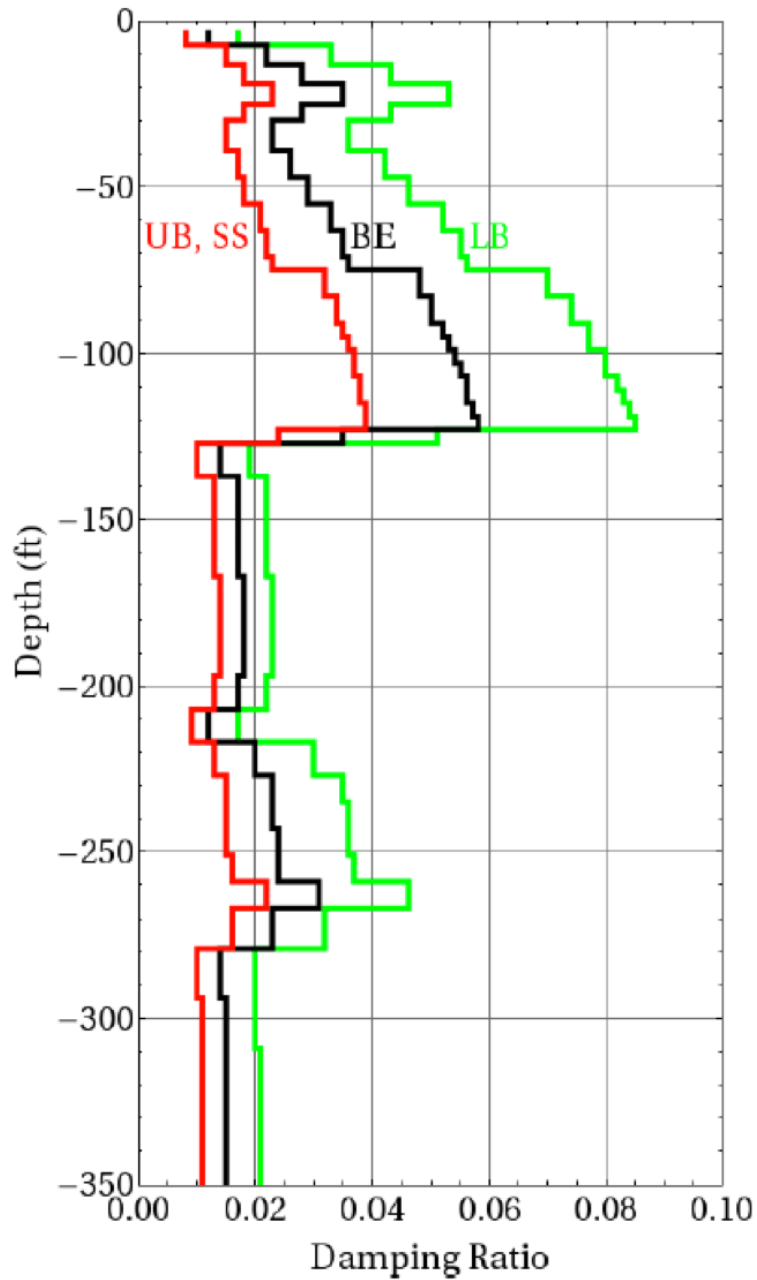
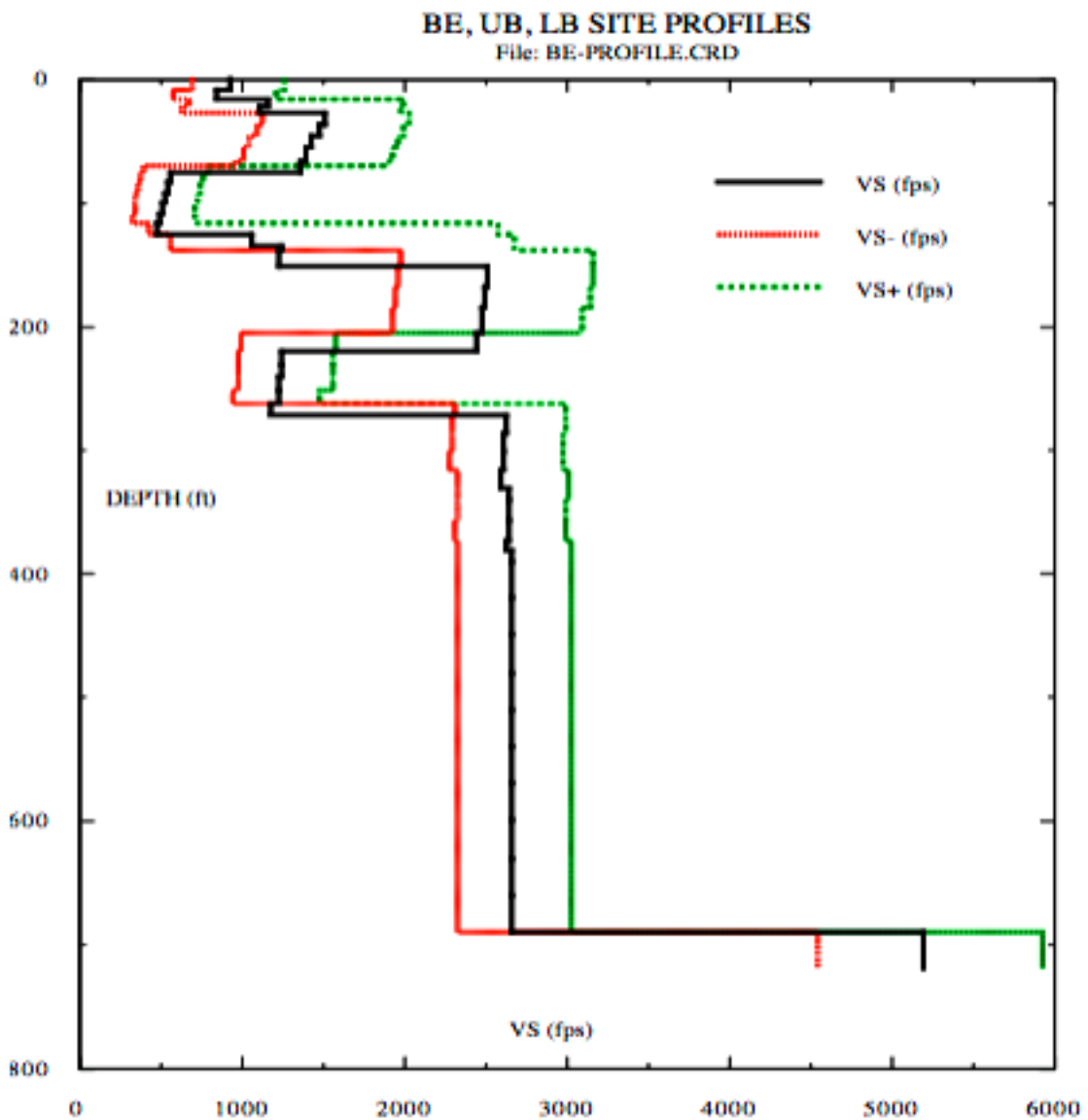

Figure B-5: CMRR Damping Ratio Profile

C Site Profiles for Primary DOE Sites

CMRR SITE



r1.png

Figure C-1: CMRR Site

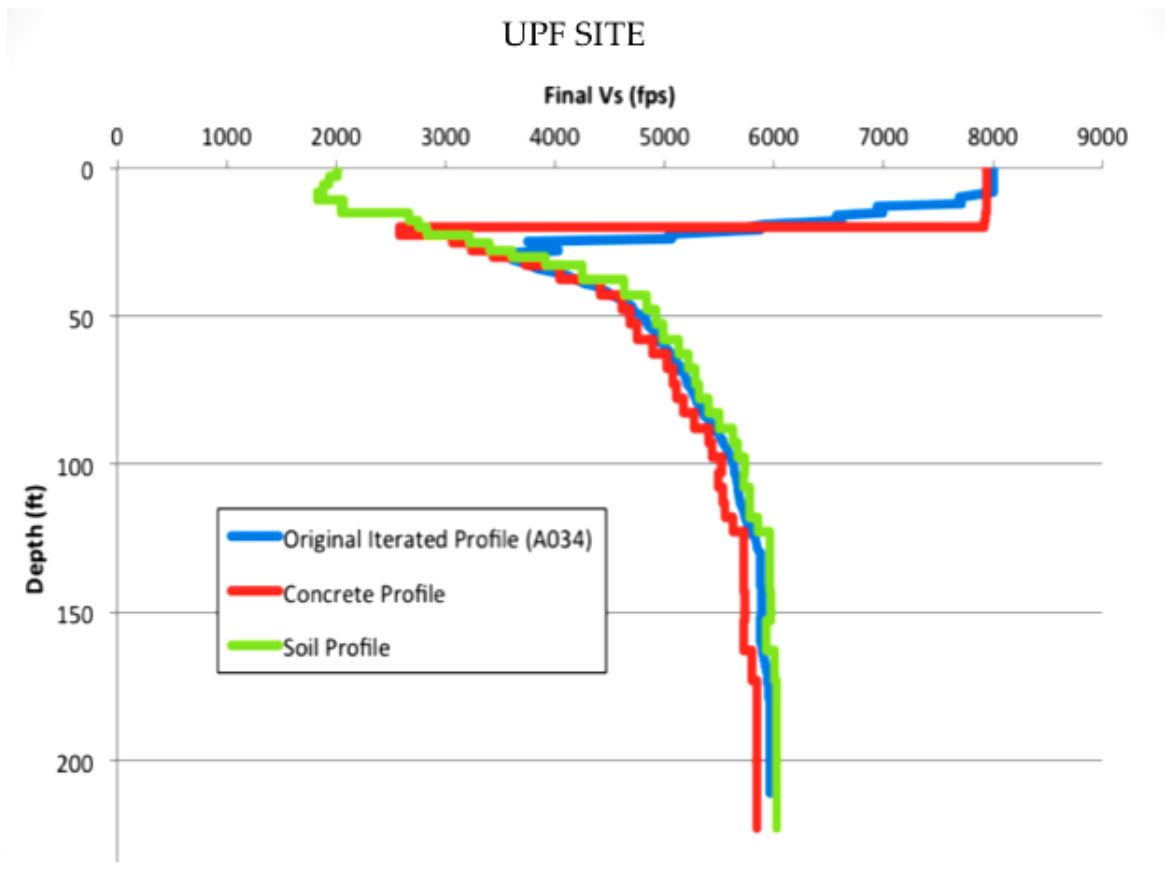

r1.png

Figure C-2: UPF Site

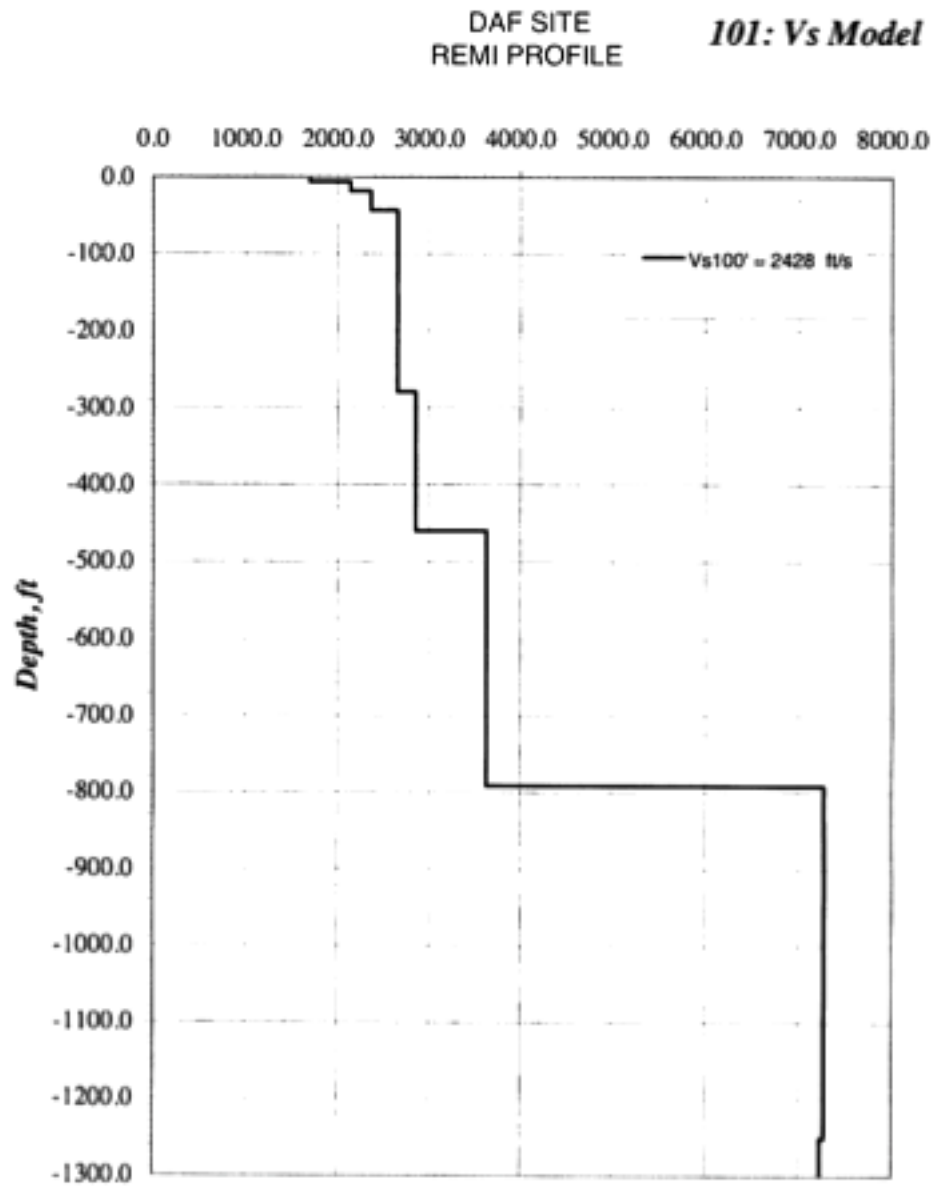

r1.png

Figure C-3: DAF Site

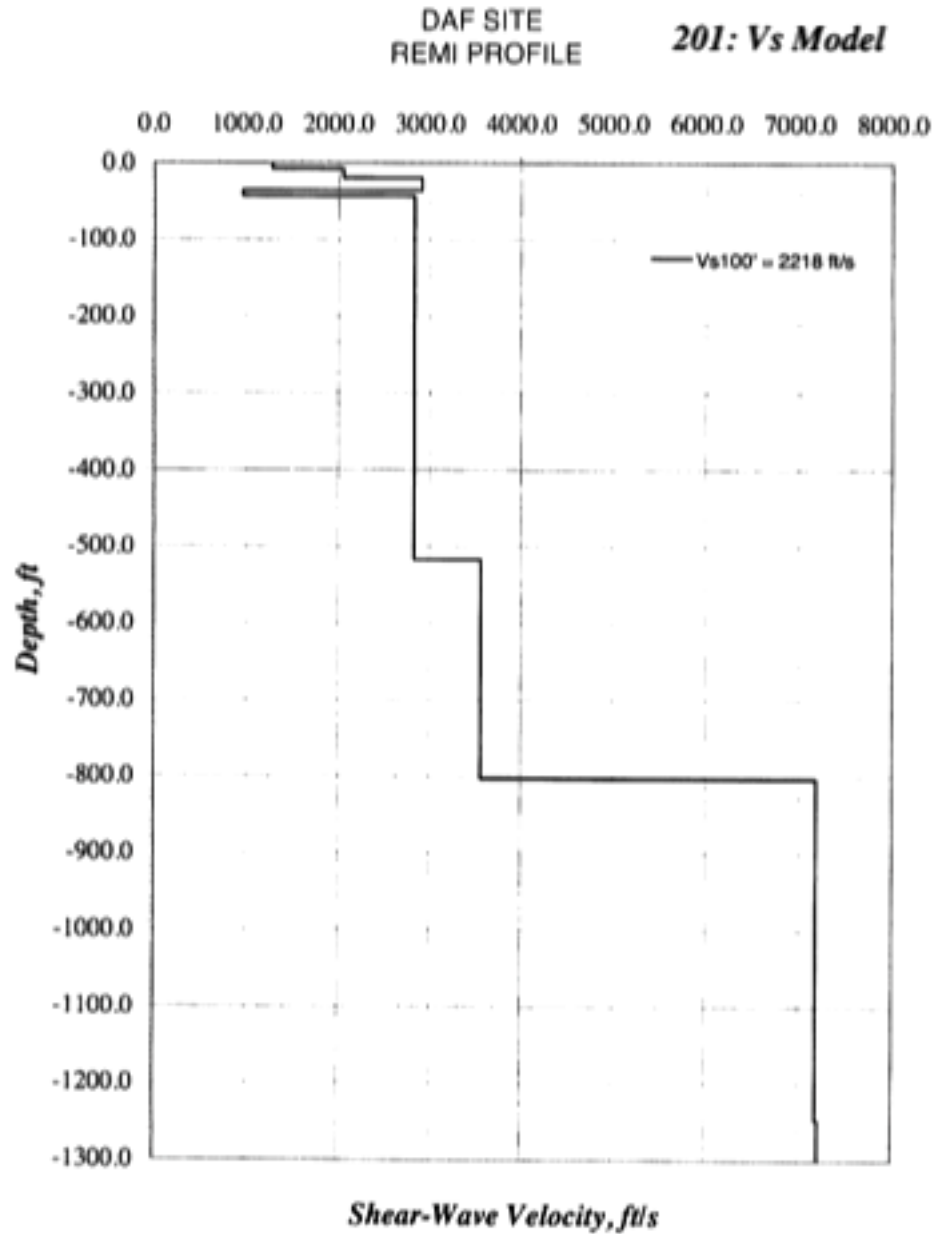

r1.png

Figure C-4: DAF Site - Remi Profile

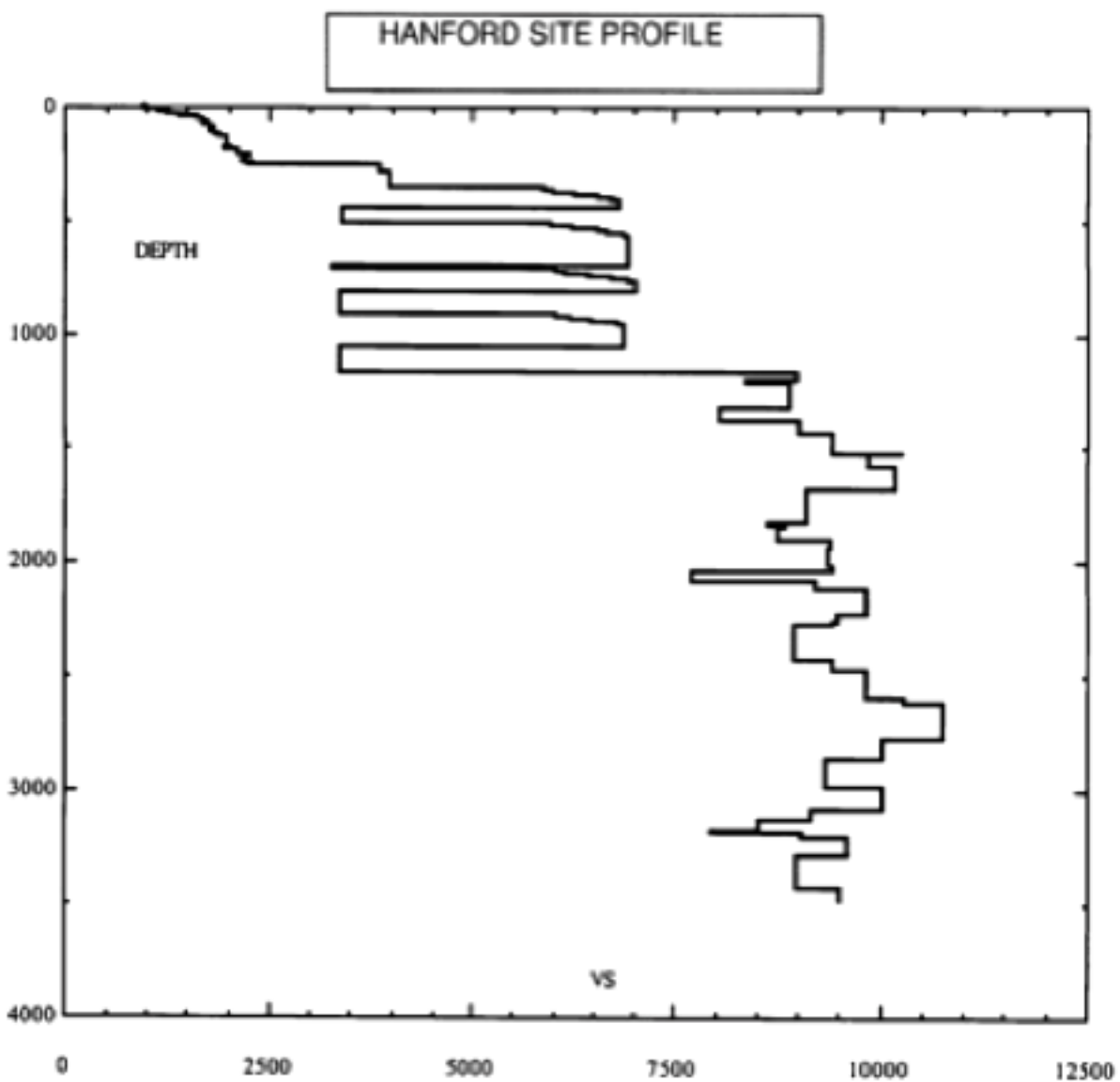

r1.png

Figure C-5: Hanford Site

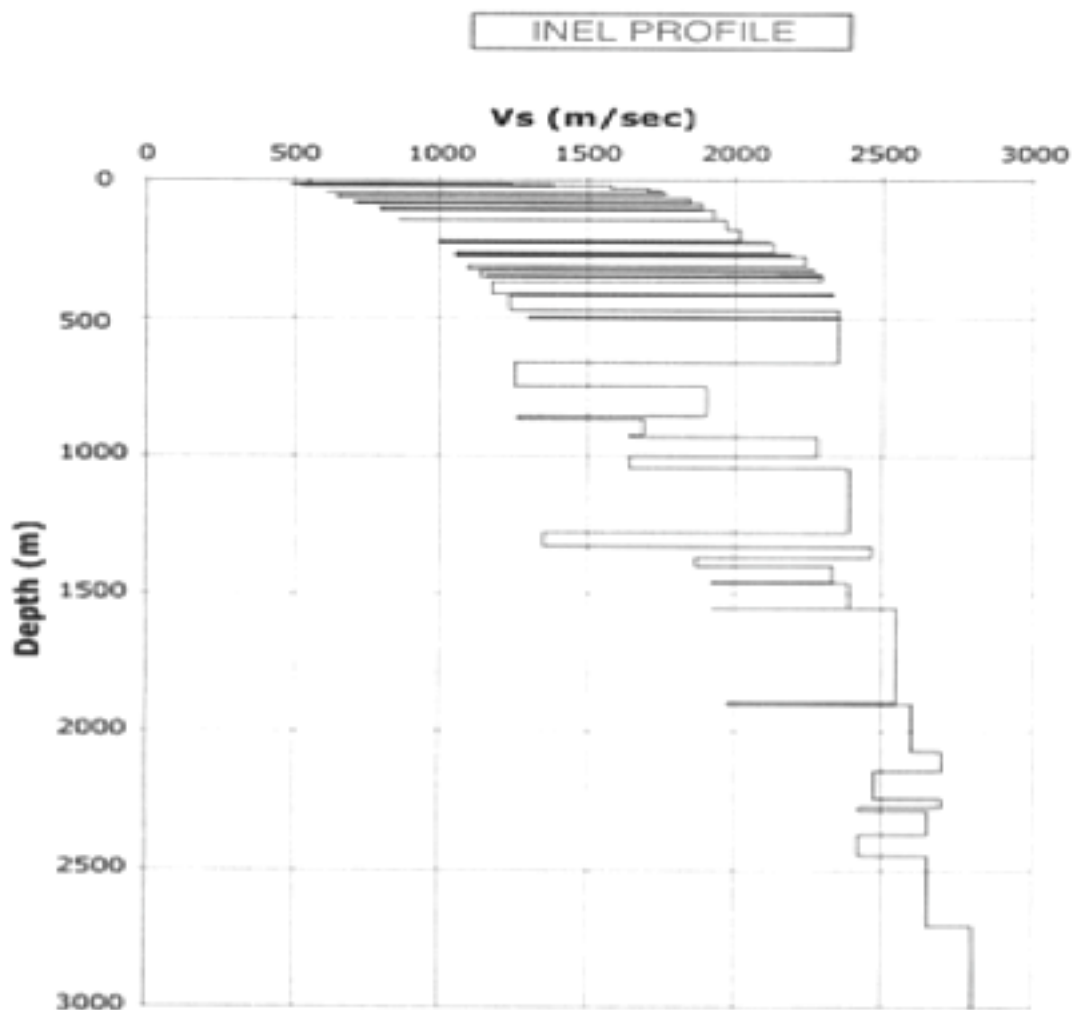

r1.png

Figure C-6: INEL Site

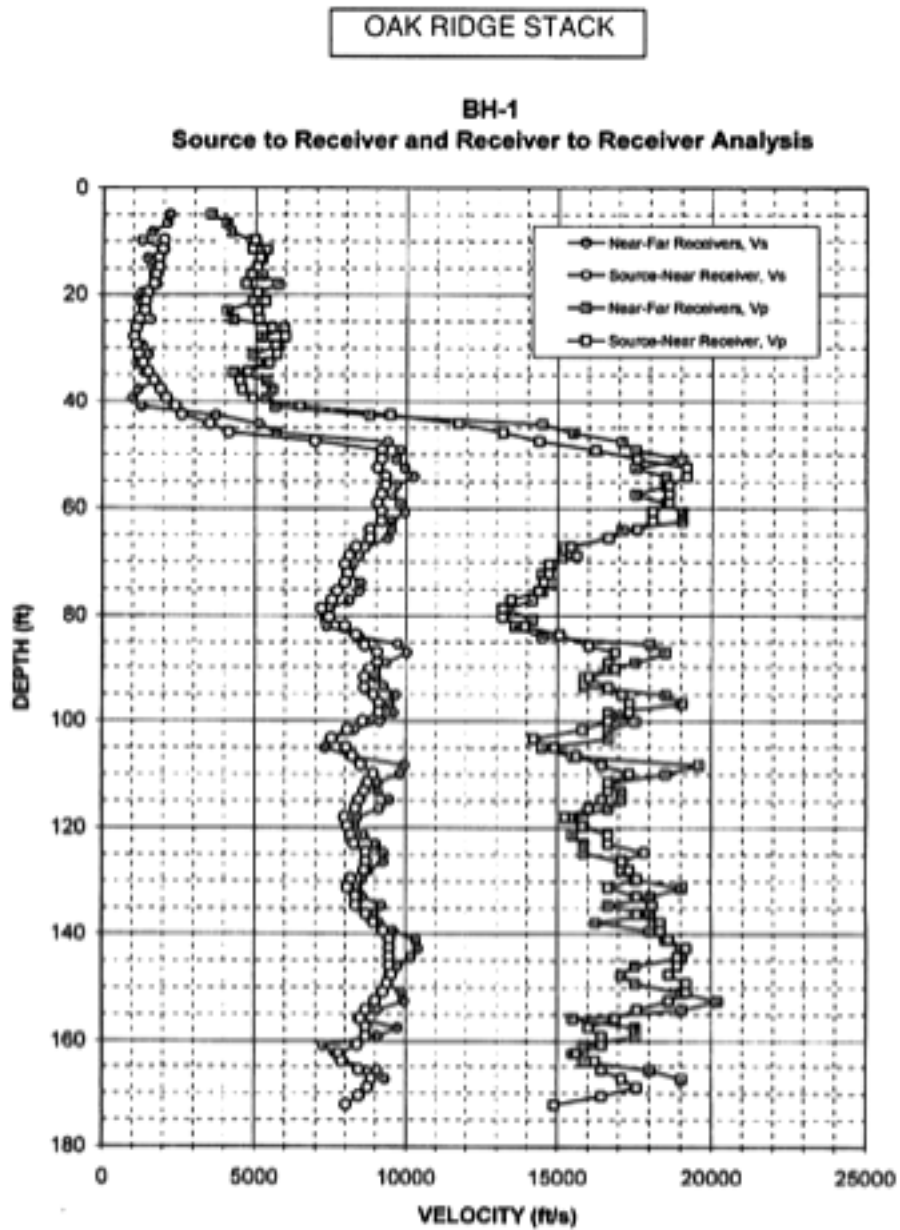

r1.png

Figure C-7: Oak Ridge Site

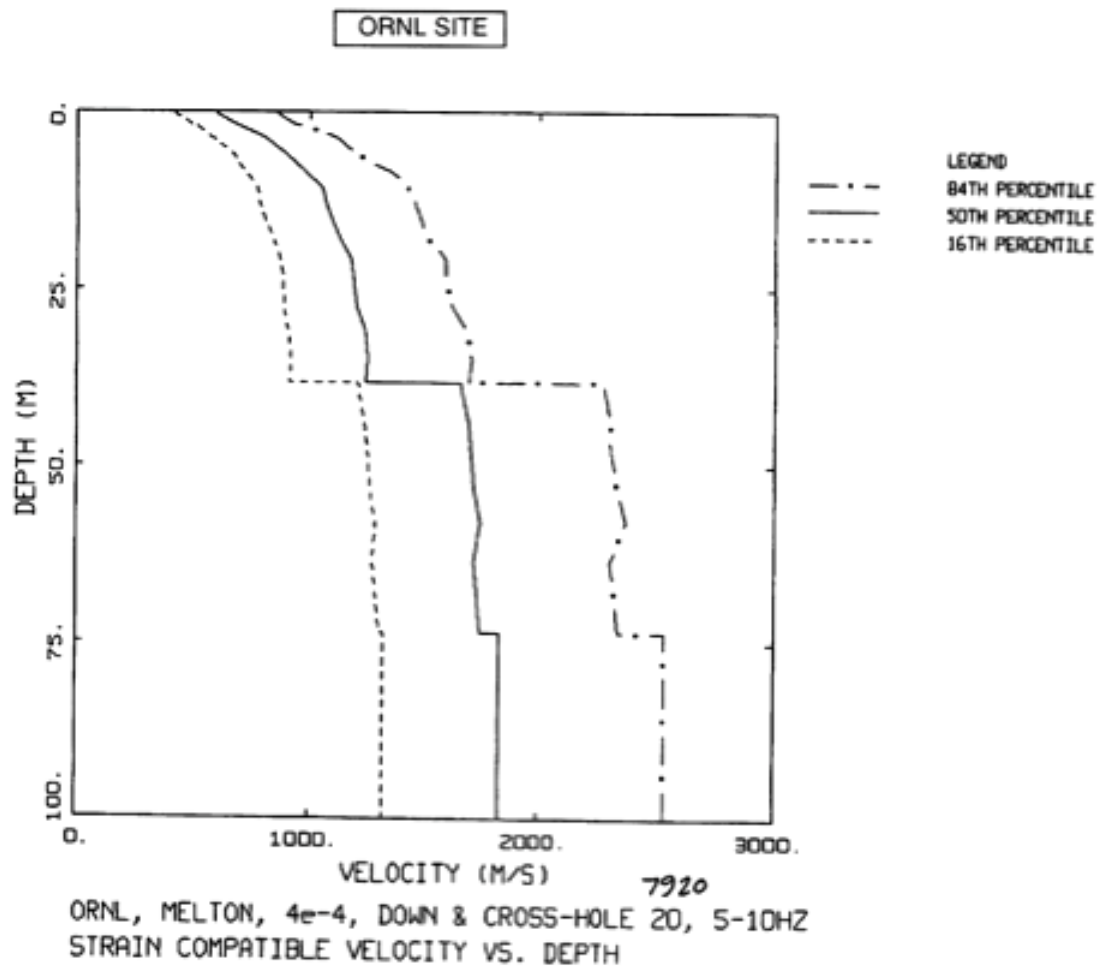

r1.png

Figure C-8: ORNL Site

SRS SITE PROFILES

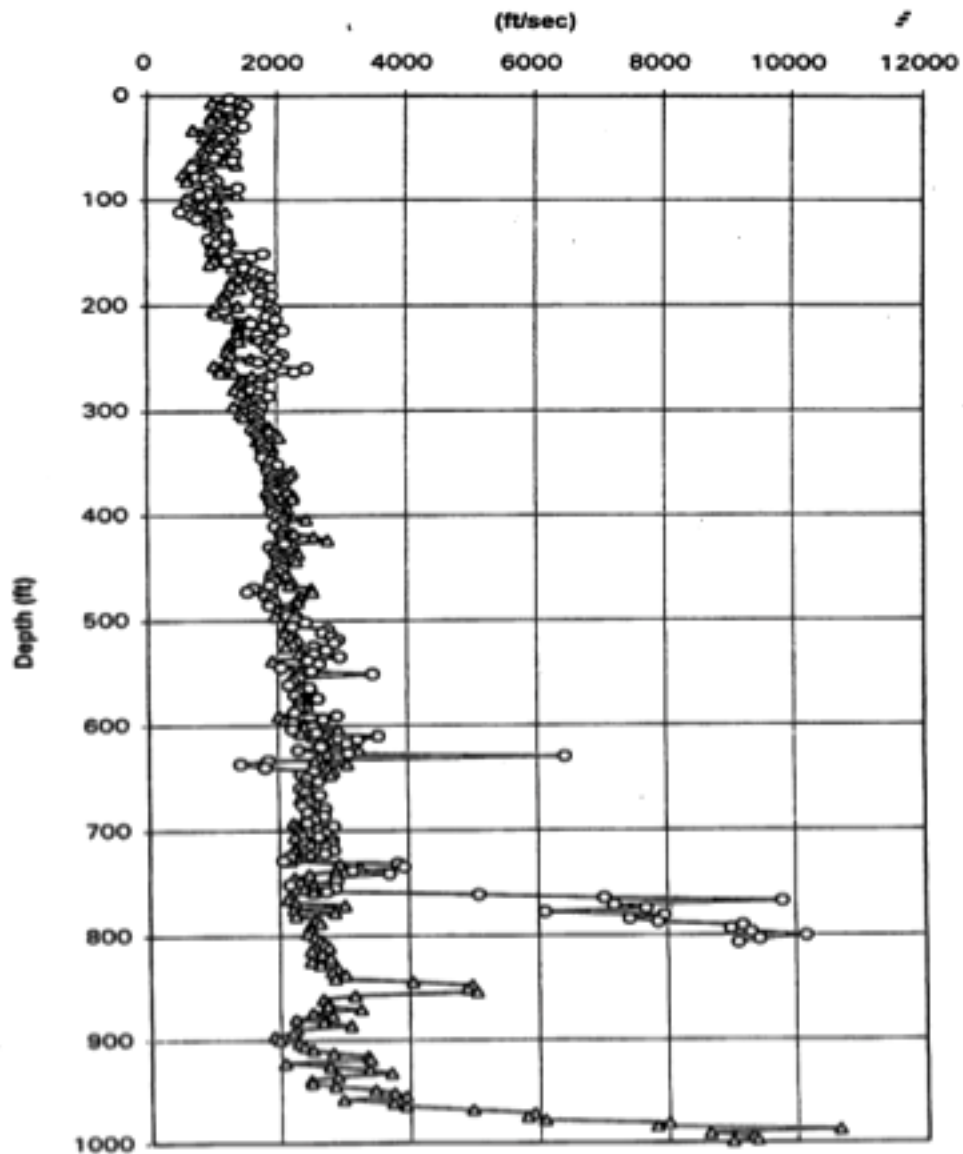

r1.png

Figure C-9: SRS Site

YUCCA MTN PROFILE

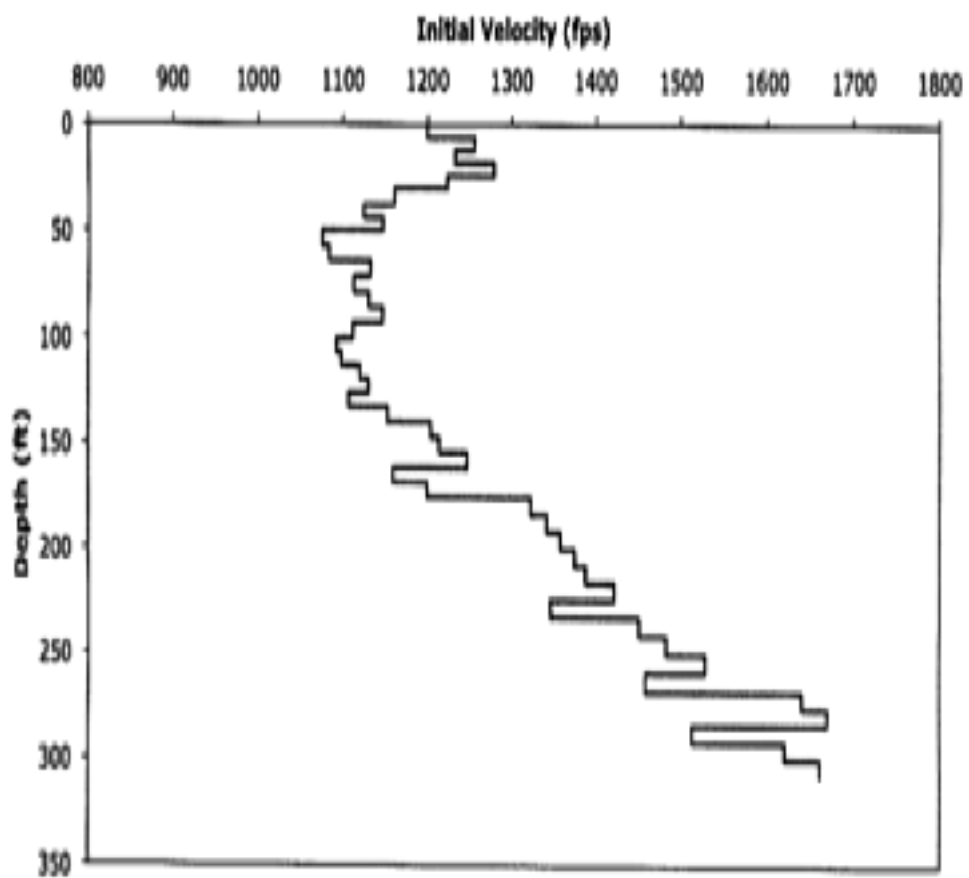

r1.png

Figure C-10: Yucca Mtn Site

D Site Profiles for NPP Sites



Figure D-1: AP600 Site Surveys

SUMMARY OF COMMERCIAL NUCLEAR POWER STATIONS SURVEYED

Plant ID Number	Nuclear Plant and Unit(s)	Location (State)	Type	CB or TB		Backfill Under		ZPA (g)	
				Embedment Depth (Ft)	Depth to Rock (Ft)	CB or TB (Ft)	Depth to Water (Ft)	SSE	OBE
1	Hope Creek, U-1	New Jersey	BWR	39-CB	1500-2000	10	0	0.2	0.1
2	Callaway, U-1	Missouri	PWR	30-CB	50	28	15	0.2	0.12
3	Palo Verde, U-1,2,3	Arizona	PWR	50-CB	334	None	44	0.2	0.1
4	Arkansas Nuclear One, U-2	Arkansas	PWR	30R-CB	30	None	11	0.2	0.1
5	Calvert Cliffs, U-1,2	Maryland	PWR	46-CB	2500	None	35	0.15	0.08
6	Wolf Creek, U-1	Kansas	PWR	40R-CB	20	None	3	0.12	0.06
7	Grand Gulf, U-1,2	Mississippi	BWR	47½-TB	>185	None	47½	0.15	0.075
8	Millsboro, U-2	Connecticut	PWR	53R-CB	53	None	19	0.17	0.09
9	Farley, U-1,2	Alabama	PWR	60R-CB	59	None	5	0.1	0.05
10	Vogtle, U-1,2	Georgia	PWR	66-CB	950	12	55	0.2	0.12
11	Hatch, U-2	Georgia	BWR	55-TB	4000	None	55	0.15	0.08
12	Susquehanna, U-1,2	Pennsylvania	BWR	31R-CB	30	None	0	0.10	0.05
13	Moericeillo	Minnesota	BWR	40-CB	40	None	20	---	0.06(DBE)
14	Davis-Besse	Ohio	PWR	40R-CB	30	None	0	0.15	0.08
15	WNP-2	Washington	BWR	34-CB	557	9	60	0.25	0.125
16	South Texas, U-1,2	Texas	PWR	59-CB	4000-6000	None	5	0.10	0.05
17	San Onofre, U-2,3	California	PWR	44-CB	850	None	24	0.67	0.33
18	Fort St. Vrain	Denver	HTGR	55R-CB	55	None	23	0.10	0.05
19	Arnold	Iowa	BWR	49R-CB	49	None	17	0.12	0.06
20	Limerick, U-1,2	Pennsylvania	BWR	50R-CB	15	None	deep	0.15	0.075
21	Trojan	Oregon	PWR	33R-CB	<5	None	>33	0.25	0.15
22	Midland, U-1,2	Michigan	PWR	57-CB	300	None	39	0.12	0.06

r1.png

Figure D-3: AP600 Site Survey Summary

SOFTER SITES

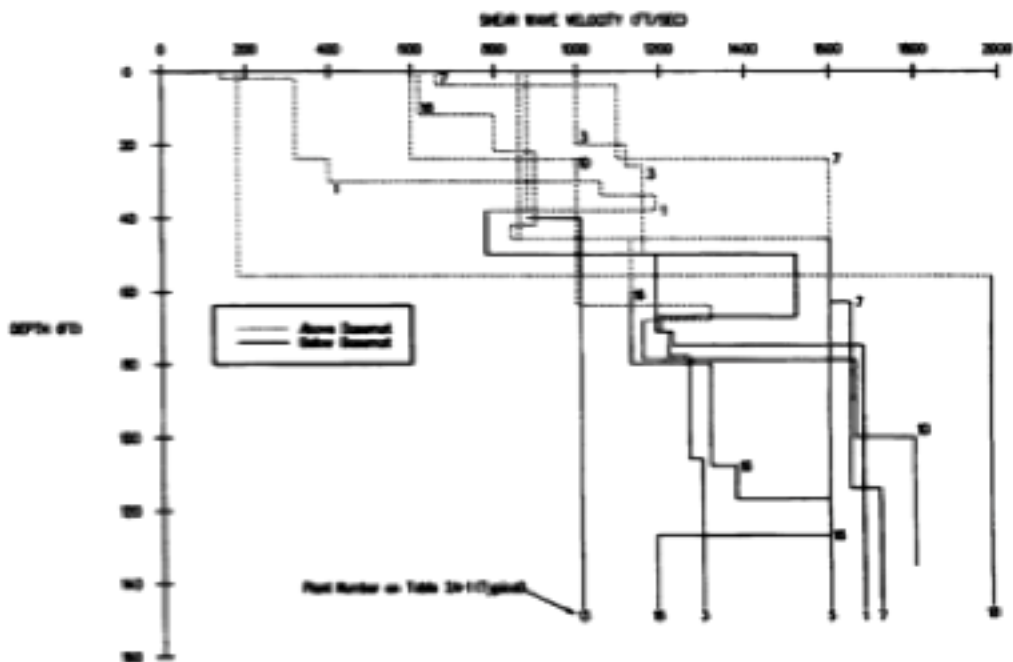

r1.png

Figure D-4: Softer Sites

STIFFER SITES

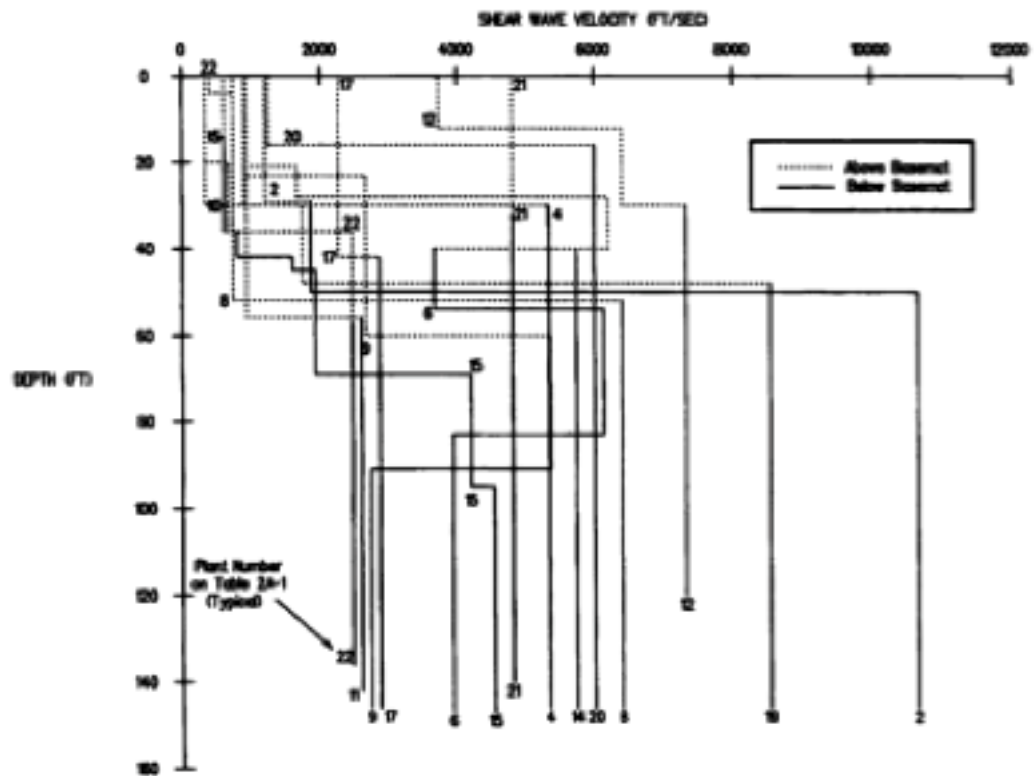

r1.png

Figure D-5: Stiffer Sites

HISTOGRAM FOR DEPTH TO BEDROCK

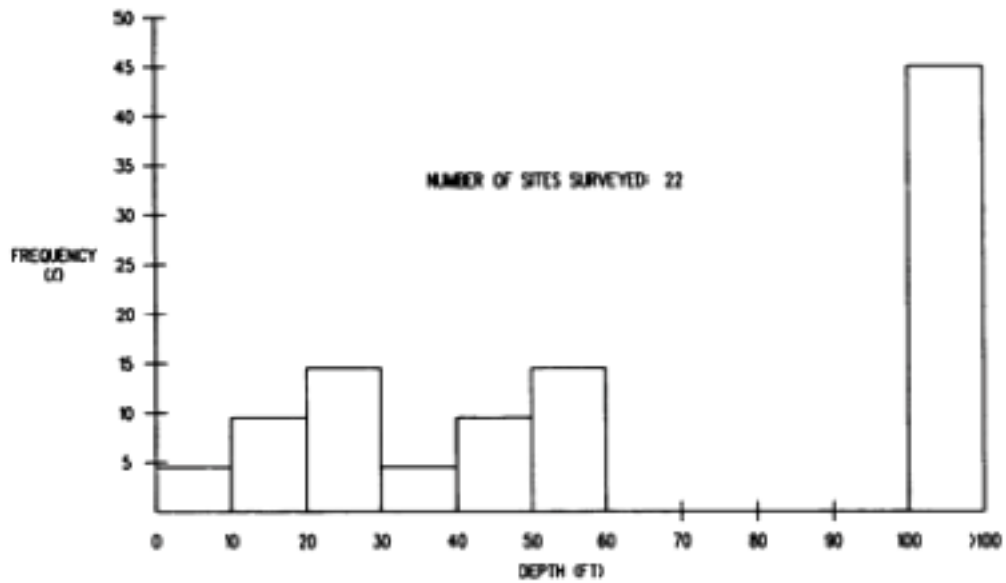

r1.png

Figure D-6: Depth to Bedrock

HISTOGRAM FOR DEPTH TO GWT

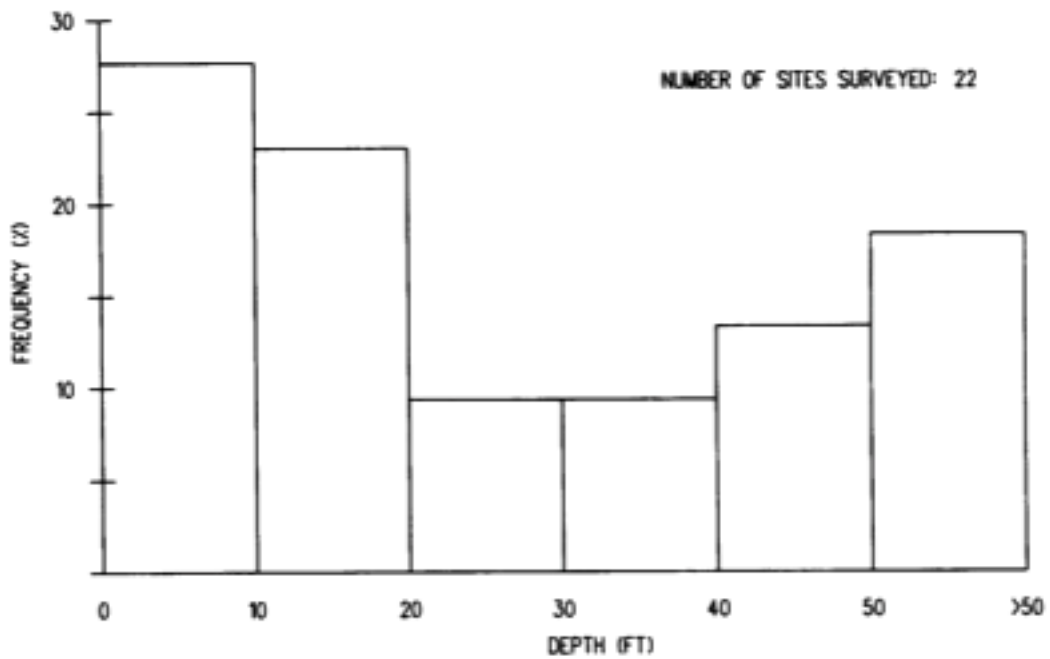

r1.png

Figure D-7: Depth to GWT

HISTOGRAM FOR EMBEDMENT DEPTH

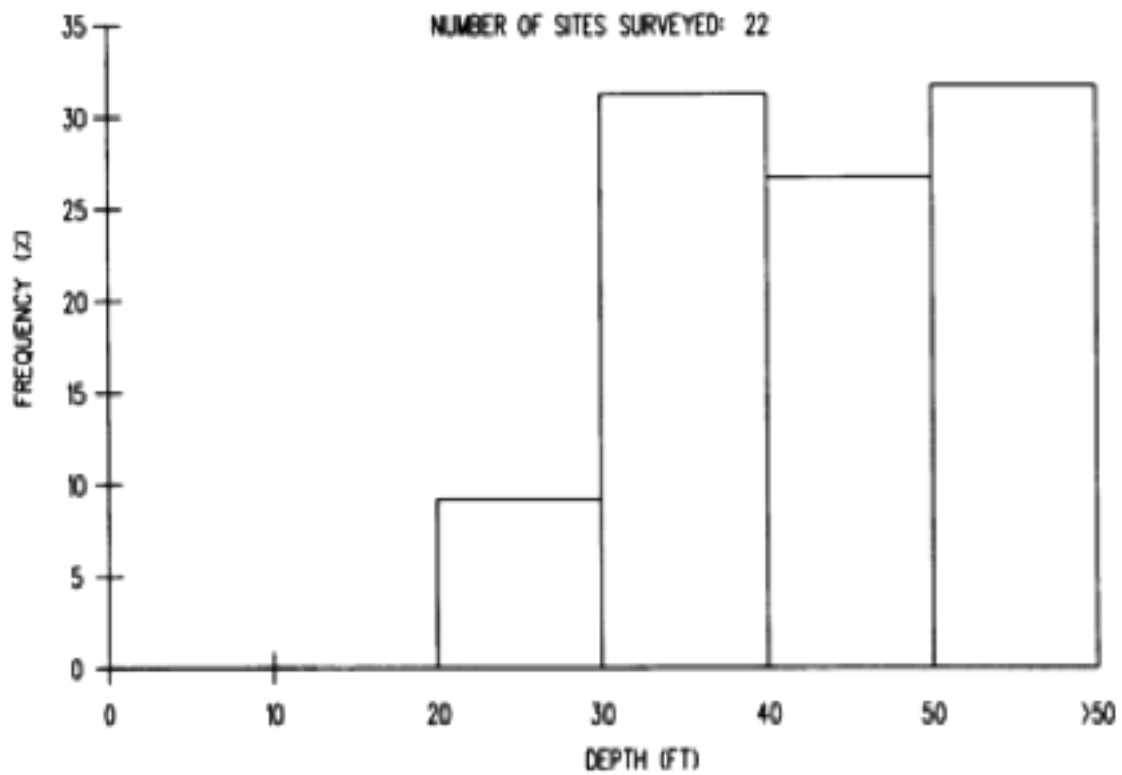

r1.png

Figure D-8: Embedment Depth

GENERIC PROFILES AP600

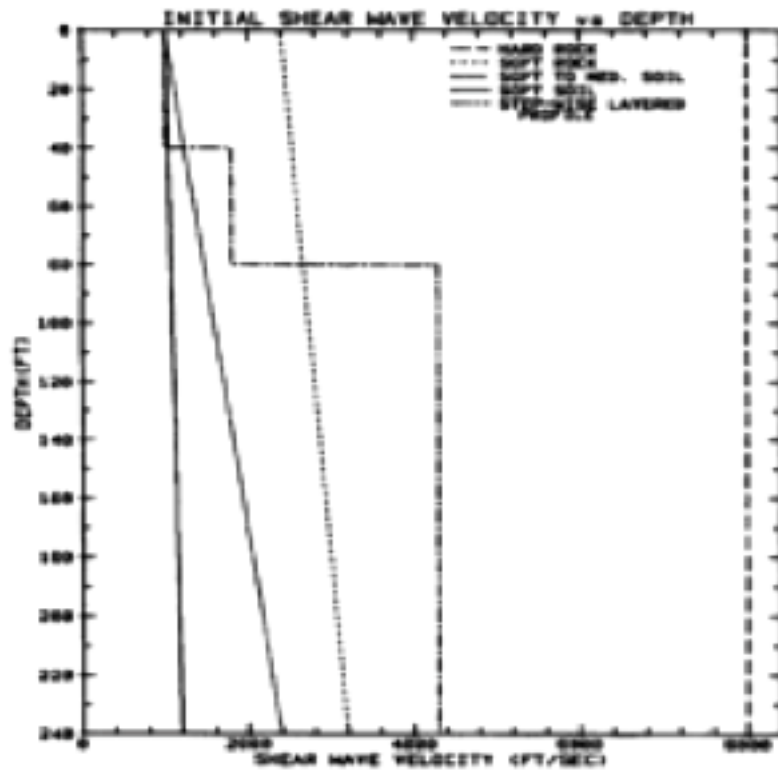

r1.png

Figure D-9: AP600 Generic Profiles

GENERIC PROFILES AP1000

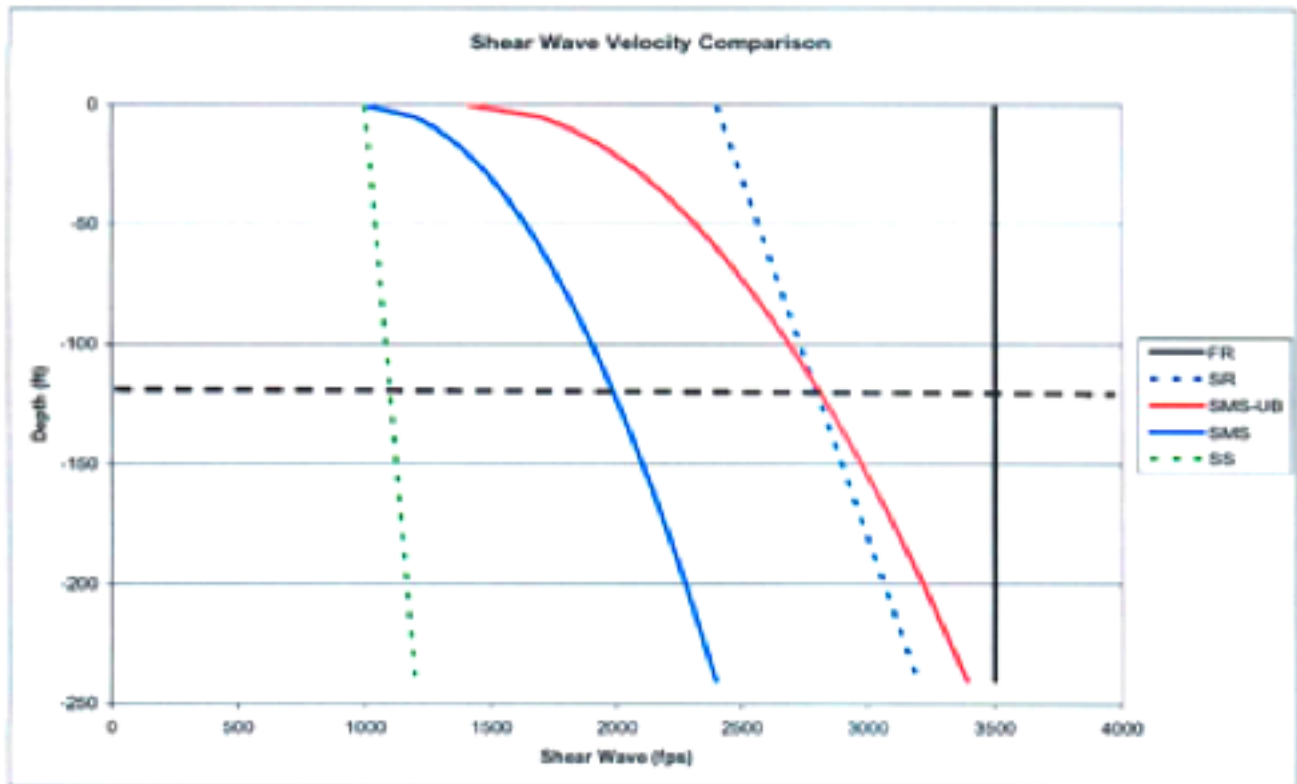

r1.png

Figure D-10: AP1000 Generic Profiles

CALVERT CLIFFS SIMULATED PROFILES

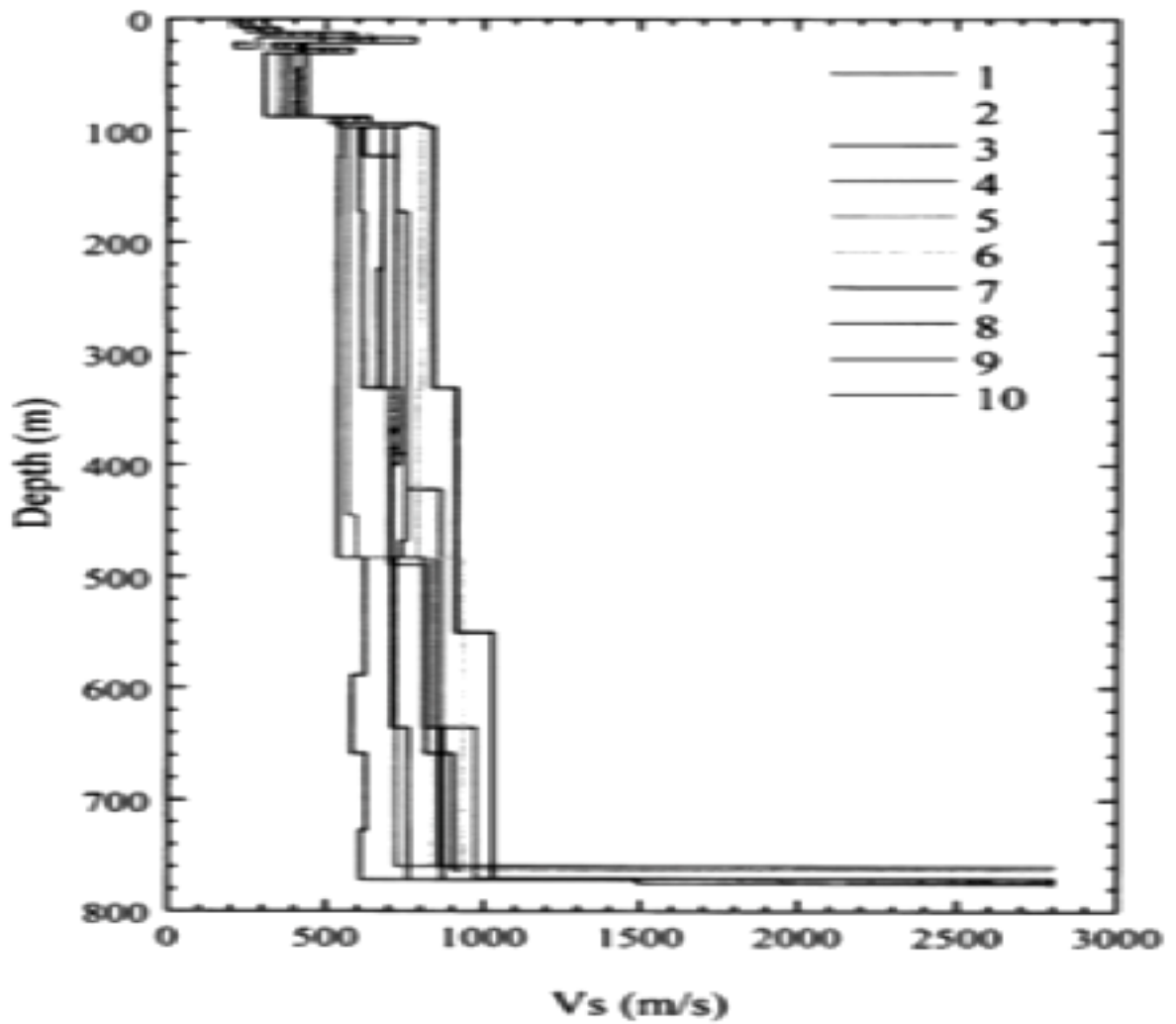

r1.png

Figure D-11: Calvert Cliffs Profiles

SOUTH TEXAS NPP SITE

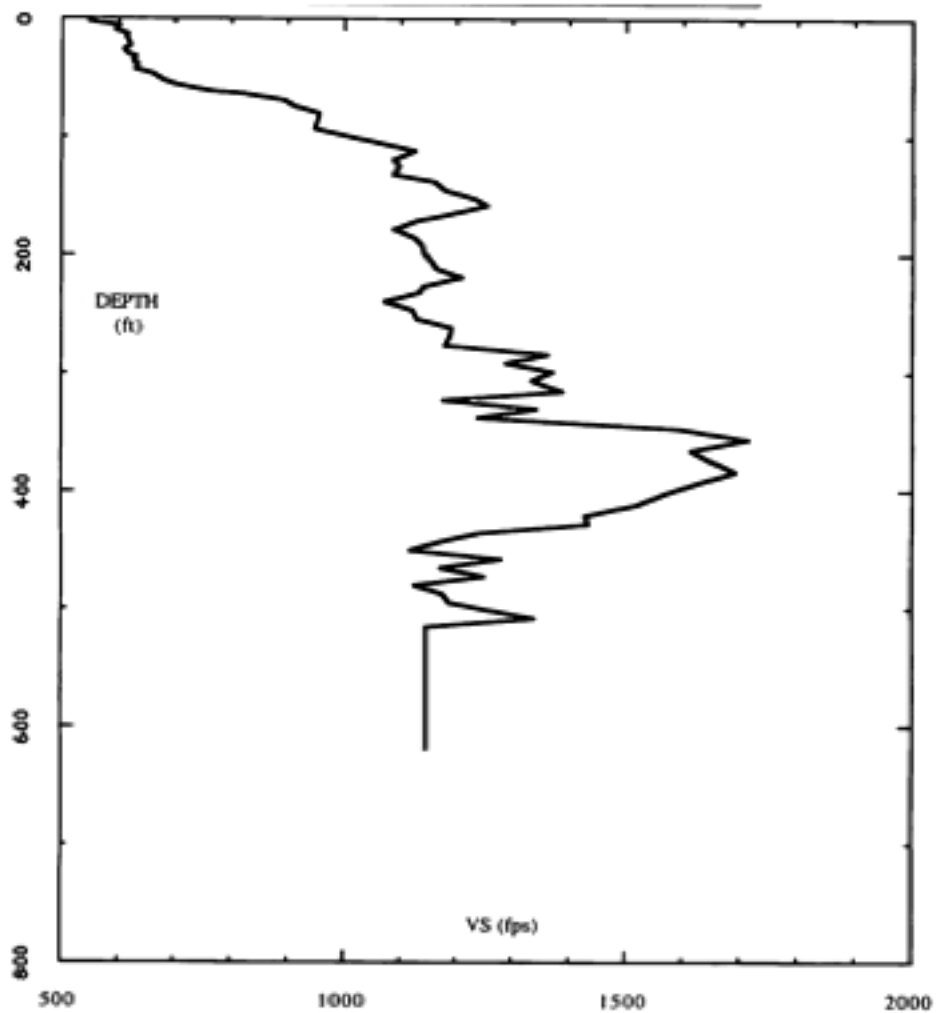

r1.png

Figure D-12: South Texas Profile

TURKEY POINT NPP SITE

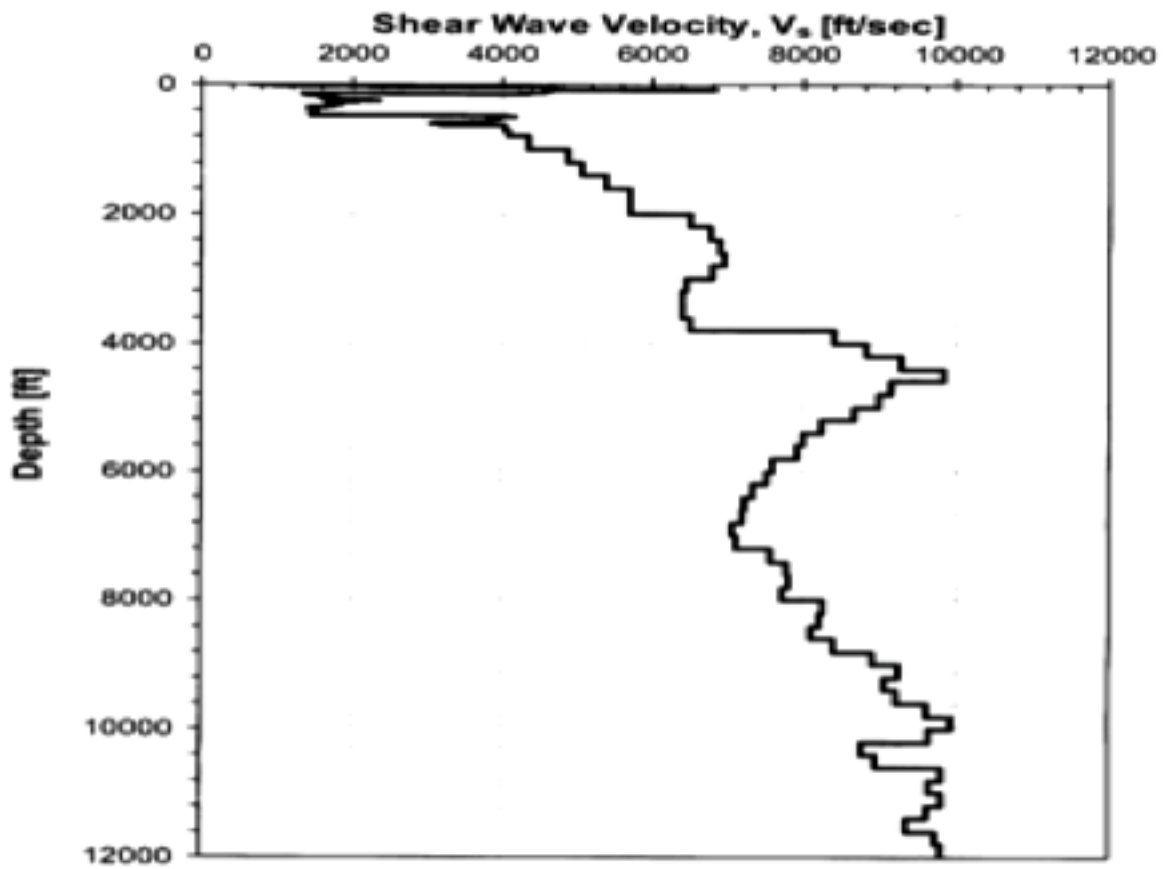

r1.png

Figure D-13: Turkey Point Profile 1

TURKEY POINT NPP SITE

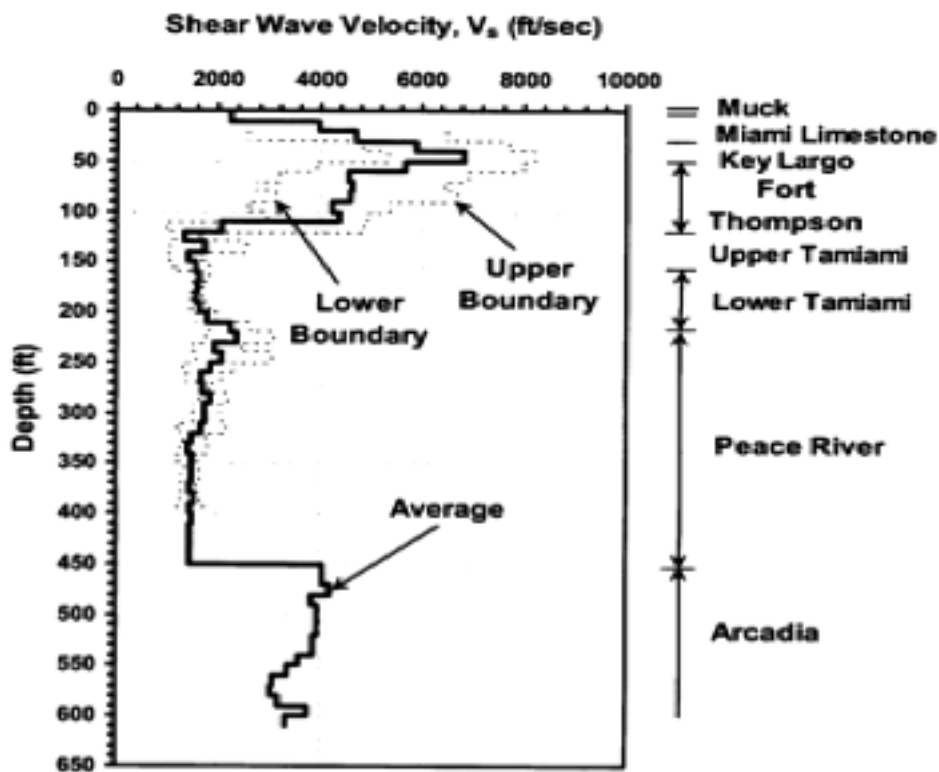

r1.png

Figure D-14: Turkey Point Profile 2

VOGTLE NPP SITE

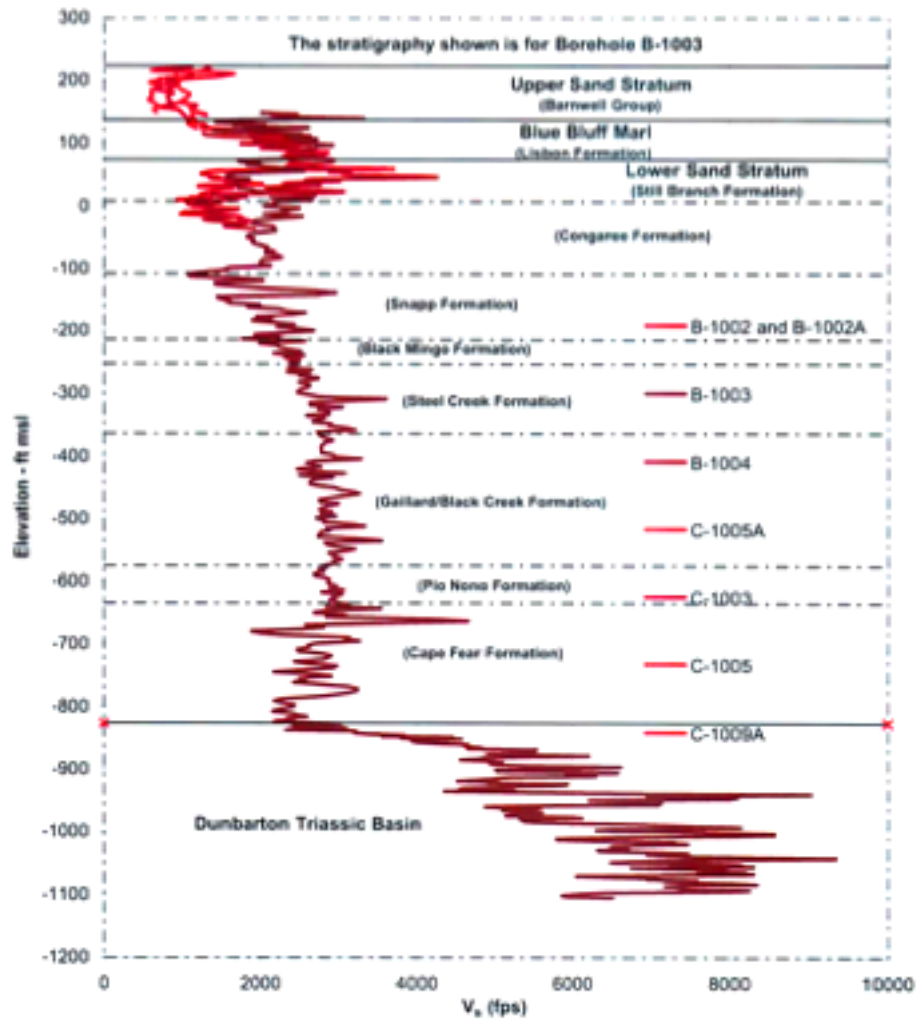

r1.png

Figure D-15: Vogtle Profile

E Detailed Listing of Input Parameters for Each Module

The input parameters for each MODULE that are specified in input files are described in this Appendix. The input parameters are used to identify the appropriate physical properties that are used in the SSI solution. These inputs are described in the SASSI2000, Rev. 1 User Manual. Any set of units may be considered as long as the units are consistent throughout each program module used for the complete run, except for those parameters with units explicitly listed below (i.e. time step of the control motion (sec), incident angle of SV and P waves (degrees), etc.).

Table E.1: SITE MODULE: Input Parameters

Input	Description	Options	Option Description
Operation Mode and Title Data			
NOPT	Operation Mode	[1, -1]	1: complete solution -1: data check only
HED	Title		
Master Control Data			
NLT	Number of soil layers	<100	
NF	Total number of frequencies of analysis	<100	
LSUB	Simulation of half-space	[0, 3<LSUB<20]	0: no simulation of half-space 3<LSUB<20: number of layers generated to simulate half-space
System of Units Data			
GRAV	Acceleration of gravity		
Soil Layer Data			
N	Layer number		
H	Layer thickness		
W	Unit weight		
VS	S-wave velocity		
VP	P-wave velocity		
DS	S-wave associated damping ratio		
DP	P-wave associated damping ratio		
Half-space Data			
WH	Unit weight		
VSH	S-wave velocity		
VPH	P-wave velocity		
DSH	S-wave associated damping ratio		

Table E.1: SITE MODULE: Input Parameters (Cont.)

Input	Description	Options	Option Description
DPH	P-wave associated damping ratio		
Frequency Data			
DF	Frequency step (Hz)		
DT	Time step of control motion (sec)		
NFFT	Number of values to be used in the Fourier transform of the control motion	[Power of 2]	NFFT must be a power of 2
Frequency Number Data			
NFR(i)	Frequency number i		
Operation Mode and Title Data			
NOPT	Operation Mode	[0,2,-1]	0: Stop 2: Complete solution for Mode 2 -1: Data check only
HED	Title		
Wave Field Type Data			
IWTYP	Description of wave field	[1,2]	1: Combination of P-, SV-, and R-waves 2: Combination of SH- and L-waves
Wave Field Type 1 Data (if IWTYP = 1)			
IRWAVE	Rayleigh wave field definition	[0,1,2]	0: No R-wave field 1: R-wave field (shortest wavelength method) 2: R-wave field (least decay method)
IVWAVE	SV wave field definition	[0,1]	0: No SV-wave field 1: SV-wave field
IPWAVE	P wave field definition	[0,1]	0: No P-wave field 1: P-wave field
ANGS	Incident angle of SV-wave (degree)		
ANGP	Incident angle of P-wave (degree)		
Wave Field Type 2 Data (if IWTYP = 2)			
ILWAVE	L wave field definition	[0,1]	0: No L-wave field

Table E.1: SITE MODULE: Input Parameters (Cont.)

Input	Description	Options	Option Description
IHWAVE	SH wave field definition	[0,1]	1: L-wave field 0: No SH-wave field 1: SH-wave field
ANGH	Incident angle of SH-wave (degree)		
Control Motion Data			
KCOMP	Direction of control motion	[X,Y,Z]	
NLCP	Layer number of control motion		
NFCP	Number of frequencies used to define ratio curve of wave participations in control motion	[≥ 2]	
Wave Composition of Control Motion on X'Z'-Plane (if IWTYP = 1)			
NFXZ(i)	Frequencies used to define ratio curve		
R-Wave Ratio Data			
XZR(i)	R-wave ratio at frequency i		
SV-Wave Ratio Data			
XZS(i)	SV-wave ratio at frequency i		
P-Wave Ratio Data			
XZP(i)	P-wave ratio at frequency i		
Wave Composition of Control Motion on Y'-axis (if IWTYP = 2)			
NFY(i)	Frequencies used to define ratio curve		
L-Wave Ratio Data			
YL(i)	L-wave ratio at frequency i		
SH-Wave Ratio Data			
YS(i)	SH-wave ratio at frequency i		

Table E.2: POINT2/POINT3 MODULE: Input Parameters

Input	Description	Options	Option Description
Operation Mode and Title Data			
NOPT	Operation Mode	[1, <0]	1: complete solution <0: data check only
HED	Title		
General Information Data			
LSTFCE	Last number in the near field zone		
RADIUS	Radius of the central zone in the point load solution	>0	

Table E.3: HOUSE MODULE: Input Parameters

Input	Description	Options	Option Description
Operation Mode and Title Data			
NOPT	Operation Mode	[1, <0]	1: complete solution <0: data check only
HED	Title		
Master Control Data			
NUMNP	Total number of nodes in the system		
NUMGP	Total number nodes at/below ground surface which act as interaction nodes		
NUMEG	Total number of different element groups		
NUML	Total number of soil layers		
NUMLM	Total number of nodes with lumped mass or inertia		
NSYMP	Total number of planes/line of symmetry or anti-symmetry	[≤2]	
NIMP	Method of computing impedance matrix	[1,2,3]	1:direct flexible volume method 2:skin flexible volume method 3:subtraction method
NDIM	Dimensions of analysis	[2,3]	2: 2-D plane-strain 3: General 3-D
System of Units Data			
GRAV	Acceleration of gravity		
Ground Elevation Data			
ZSRFCE	Z-coordinate of ground level		
Plane(s)/Line of Symmetry/Anti-Symmetry Data			
N	Plane/line pf symmetry/anti-symmetry number		
NPLTYP(N)	Type of plane for plane N	[-1,1]	1: symmetry -1: anti-symmetry
NPT(1,N)	First reference nodal point number for plane N		
NPT(2,N)	Second reference nodal point number for plane N		
NPT(3,N)	Third reference nodal point number for plane N		
Nodal Point Data			
N	Nodal point number		

Table E.3: HOUSE MODULE: Input Parameters (Cont.)

Input	Description	Options	Option Description
NC	Symbol describing coordinate system	['blank',C,S]	'blank': Cartesian (x,y,z) C: Cylindrical (R, θ ,Z) S: Spherical (R, θ , φ)
ID	Boundary condition code	[0,1]	0: Free 1: Fixed
XORD(N)	X-ordinate of node N		R if cylindrical or spherical
YORD(N)	Y-ordinate of node N		θ -degree for cylindrical or spherical
ZORD(N)	Z-ordinate of node N		Z direction must be the vertical model direction
KN	Node number increment for node number generation		
Interaction Nodes Data ¹			
INTACT	Total number of interaction nodes		
N(i)	Node number of interaction nodes		
Soil Layer Data			
N	Layer number		
G	Thickness		
W	Unit weight		
VS	S-wave velocity		
VP	P-wave velocity		
DS	S-wave associated damping ratio		
DP	P-wave associated damping ratio		
Three-Dimensional Soil Elements (Eight-node Brick) Data			
Control Information			
NPAR(1)	Element key	[1]	
NPAR(2)	Total number of 8-node soil elements		
NPAR(3)	Number of material types		
NPAR(4)	Material property code	[-1,0,1]	-1: Input Elastic modulus and Poisson's ratio 0: Input constrained and shear moduli 1: Input P- and S-wave velocities
NPAR(5)	Incompatible mode code	[0, \neq 0]	0: Include incompatible modes

¹Skin Method is not included in this listing

Table E.3: HOUSE MODULE: Input Parameters (Cont.)

Input	Description	Options	Option Description
			≠0: Suppress incompatible modes
Material Property Data			
N	Material type number		
M(N)	Elastic modulus/constrained modulus/P-wave velocity		
G(N)	Poisson's ratio/shear modulus/S-wave velocity		
W(N)	Unit weight of material		
DP(N)	P-wave associated damping ratio		
DS(N)	S-wave associated damping ratio		
Eight-noded Solid Element Data			
INEL	Element number		
INP(1-8)	Nodal point numbers 1 through 8		
ININT	Integration order		
INTYP	Element type	[1,-1]	1: Structural element -1: Excavated soil element
IMAT	Material-type number for structural elements/soil layer number for soil elements		
IINC	Element generator code		
Three-Dimensional Beam Element Data			
Control Information			
NPAR(1)	Element key	[2]	
NPAR(2)	Total number of beam elements		
NPAR(3)	Number of material types		
NPAR(4)	Number of geometric property types		
NPAR(5)	Material property code	[-1,0,1]	-1: Input Elastic modulus and Poisson's ratio 0: Input constrained and shear moduli 1: Input P- and S-wave velocities
Material Property Data			
N	Material type number		
M(N)	Elastic modulus/constrained modulus/P-wave velocity		
G(N)	Poisson's ratio/shear modulus/S-wave velocity		

Table E.3: HOUSE MODULE: Input Parameters (Cont.)

Input	Description	Options	Option Description
W(N)	Unit weight of material		
DP(N)	P-wave associated damping ratio		
DS(N)	S-wave associated damping ratio		
Element Geometric Property Data			
N	Geometric property number		
ELP(1,N)	Axial area		
ELP(2,N)	Shear area associated with shear forces in local 2-direction		
ELP(3,N)	Shear area associated with shear forces in local 3-direction		
ELP(4,N)	Torsional inertia		
ELP(5,N)	Flexural inertia about local 2-axis		
ELP(6,N)	Flexural inertia about local 3-axis		
Beam Element Data			
INEL	Element number		
INI	Node number I		
INJ	Node number J		
INK	Node number K		
IMAT	Material property number		
IMEL	Element geometry property number		
IINC	Element generator code		
IB1	End release code at node number I		
IB2	End release code at node number J		
Plate/Shell Element Data			
Control Information			
NPAR(1)	Element key	[3]	
NPAR(2)	Total number of plate/shell elements		
NPAR(3)	Number of material types		
NPAR(4)	Material property code	[-1,0,1]	-1: Input Elastic modulus and Poisson's ratio 0: Input constrained and shear moduli 1: Input P- and S-wave velocities
Material Property Data			
N	Material type number		
M(N)	Elastic modulus/constrained modulus/P-wave velocity		
G(N)	Poisson's ratio/shear modulus/S-wave velocity		

Table E.3: HOUSE MODULE: Input Parameters (Cont.)

Input	Description	Options	Option Description
W(N)	Unit weight of material		
DP(N)	P-wave associated damping ratio		
DS(N)	S-wave associated damping ratio		
Plate/Shell Element Data			
INEL	Element number		
INP(1-4)	Nodal point numbers 1 through 4		
INP(5)	Key to compute mid-node properties		
IMAT	Material-type number		
IINC	Element generator code		
TH	Element thickness		
Two-Dimensional Finite Element Data			
Control Information			
NPAR(1)	Element key	[4]	
NPAR(2)	Total number of 2-D finite elements		
NPAR(3)	Number of material types		
NPAR(4)	Material property code	[-1,0,1]	-1: Input Elastic modulus and Poisson's ratio 0: Input constrained and shear moduli 1: Input P- and S-wave velocities
Material Property Data			
N	Material type number		
M(N)	Elastic modulus/constrained modulus/P-wave velocity		
G(N)	Poisson's ratio/shear modulus/S-wave velocity		
W(N)	Unit weight of material		
DP(N)	P-wave associated damping ratio		
DS(N)	S-wave associated damping ratio		
2-D Finite Element Data			
INEL	Element number		
INP(1-4)	Nodal point numbers 1 through 4		
INTYP	Element type	[1,-1]	1: Structural element -1: Excavated soil element
IMAT	Material-type number for structural elements/soil layer number for soil elements		
IINC	Element generator code		

Table E.3: HOUSE MODULE: Input Parameters (Cont.)

Input	Description	Options	Option Description
Three-Dimensional Spring Element Data			
Control Information			
NPAR(1)	Element key	[7]	
NPAR(2)	Total number of spring elements		
NPAR(3)	Number of different element types		
Spring Element Type Data			
SPR(1,N)	Translational spring constant in global x-direction		
SPR(2,N)	Translational spring constant in global y-direction		
SPR(3,N)	Translational spring constant in global z-direction		
SPR(4,N)	Rotational spring constant in global xx-direction		
SPR(5,N)	Rotational spring constant in global yy-direction		
SPR(6,N)	Rotational spring constant in global zz-direction		
SPR(7,N)	Damping ratio		
Spring Element Data			
INEL	Element number		
INI	Node numbers I		
INJ	Node numbers J		
IMAT	Element-type		
IINC	Generator code		
Stiffness/Mass Matrix Element Data			
Control Information			
NPAR(1)	Element key	[9]	
NPAR(2)	Total number of matrix elements		
NPAR(3)	Mass type code	[0,≠0]	0: Enter mass ≠0: Enter weight
Mass Matrix Element Data			
NEL	Element number		
NI	Node number I		
NJ	Node number J		
NK	Node number K		
Element Stiffness/Mass Matrix Data			
NR(I)	Row number		
NC(I)	Column number		

Table E.3: HOUSE MODULE: Input Parameters (Cont.)

Input	Description	Options	Option Description
ZSR(I)	Real part of stiffness term		
ZSI(I)	Imaginary part of stiffness term		
ZM(I)	Mass/weight value		
Concentrated Lumped Mass Data			
N	Nodal point number		
XMASS (N,1)	Translational mass acting in x-direction		
XMASS (N,2)	Translational mass acting in y-direction		
XMASS (N,3)	Translational mass acting in z-direction		
XMASS (N,4)	Rotational mass acting in xx-direction		
XMASS (N,5)	Rotational mass acting in yy-direction		
XMASS (N,6)	Rotational mass acting in zz-direction		

Table E.4: MOTOR MODULE: Input Parameters

Input	Description	Options	Option Description
Operation Mode and Title Data			
NOPT	Operation Mode	[1, <0]	1: Complete solution <0: Data check only
HED	Title		
Master Control Data			
NLP	Total number of loaded points		
NF	Total number of frequencies of analyses		
System of Units Data			
GRAV	Acceleration of gravity		
Frequency Data			
DF	Frequency step (Hz)		
DT	Time step of control motion (sec)		
NFFT	Number of values to be used in the Fourier transform of the control motion	[Power of 2]	NFFT must be a power of 2
Frequency Number Data			
NFR(i)	Frequency number i		
Concentrated Dynamic Load Data			
NODE(1)	Nodal point number		
AMPL(1)	Force factor in x-direction		
AMPL(2)	Force factor in y-direction		
AMPL(3)	Force factor in z-direction		
AMPL(4)	Moment factor in xx-direction		
AMPL(5)	Moment factor in yy-direction		
AMPL(6)	Moment factor in zz-direction		
KN	Node number increment		
KT	Arrival time code	[0,-1]	0: zero arrival time -1: nonzero arrival time
Additional Load Data (If KT = 0)			
DTX	Force arrival time in x-direction (sec)		
DTY	Force arrival time in y-direction (sec)		
DTZ	Force arrival time in z-direction (sec)		
DTXX	Moment arrival time in xx-direction (sec)		

Table E.4: MOTOR MODULE: Input Parameters (Cont.)

Input	Description	Options	Option Description
DTYY	Moment arrival time in yy-direction (sec)		
DTZZ	Moment arrival time in zz-direction (sec)		

Table E.5: ANALYS MODULE: Input Parameters

Input	Description	Options	Option Description
Operation Mode and Title Data			
NOPT	Operation Mode	[1, <0]	1: Complete solution <0: Data check only
HED	Title		
Master Control Data			
MEOF	Type of analysis	[1,2]	1: Seismic analyses 2: Foundation vibration analyses
MODE	Mode of analysis	[1,2,3,4]	1: Initiation 2: Restart; new superstructure 3: Restart; new seismic environment 4: Restart; new dynamic loading
MSAVE	Reduced complex stiffness save option	[0,1]	0: Do not save reduced complex stiffness 1: Save reduced complex stiffness
NPRINT	Print option	[0,<0,n]	0: Do not print transfer functions <0: Print transfer functions for all non-fixed nodes n: Print transfer functions for n nodes only
NUMFR	Number of frequencies of analysis	[>0,0]	>0: Total number of frequencies of analyses 0: NUMFR and frequency numbers taken from data in SITE Module
Frequency Number Data			
NFR(i)	Frequency number		
Control Motion Card for Seismic Analysis			
XCNTROL	X-coordinate of control point		
YCNTROL	Y-coordinate of control point		
ANG	Coordinate transformation angle (degrees)		

Table E.6: MOTION MODULE: Input Parameters

Input	Description	Options	Option Description
Operation Mode and Title Data			
NOPT	Operation Mode	[1, <0]	1: Complete solution <0: Data check only
HED	Title		
Output Control Data			
NTIME	Analysis type code	[0,1]	0: Only transfer functions to be output 1: Otherwise
NOUT	Total number of nodal points where output is required		
ND	Number of constant damping values for response spectrum analysis		
NSKIP	Output code for all time histories	[0,>1]	0: Only table to be printed >1: Plot every NSKIP point
DUR	Total duration of time histories to be plotted		
Response Spectra Data			
FSTRT	First frequency used in response spectrum analysis (Hz)		
FLAST	Last frequency used in response spectrum (Hz)		
NINT	Total number of frequency steps for response spectra		
DAMP(n)	Damping ratios used in response spectra		
Input Motion Data			
NFFT	Number of values to be used in the Fourier Transform		
NEQZ	Number of acceleration (or force) values to be read		
DT	Time step (sec)		
EQMUL	Multiplication factor for scaling time history		

Table E.7: STRESS MODULE: Input Parameters

Input	Description	Options	Option Description
Operation Mode and Title Data			
NOPT	Operation Mode	[1, <0]	1: Complete solution <0: Data check only
HED	Title		
Master Control Data			
NGOUT	Total number of element groups		
ITER	Iteration control key	[0]	
IFPU	Output control key	[0,1]	1: Save stress time history data 0: Do not save data
Three-Dimensional Soil Element Data			
Control Information Data			
ICODE(1)	Element type code	[1]	
ICODE(2)	Element group order number		
ICODE(3)	Total number of elements in the group for which output is requested		
Output Request Data			
N	Element number		
Key(1)	Output key for stress/strain in xx-direction		
Key(2)	Output key for stress/strain in yy-direction		
Key(3)	Output key for stress/strain in zz-direction		
Key(4)	Output key for stress/strain in xy-direction		
Key(5)	Output key for stress/strain in xz-direction		
Key(6)	Output key for stress/strain in yz-direction		
Key(7)	Output key for octahedral shear stress/strain		
KN	Generation control key	[0,1]	0: No generation 1: Otherwise
Three-Dimensional Beams Element Data			
Control Information Data			
ICODE(1)	Element type code	[2]	
ICODE(2)	Element group order number		
ICODE(3)	Total number of elements in the group for which output is requested		
Output Request Data			
N	Element number		
KEY(1)	Output control key for force in 1-direction (nodes J)		

Table E.7: STRESS MODULE: Input Parameters (Cont.)

Input	Description	Options	Option Description
KEY(2)	Output control key for force in 2-direction (nodes J)		
KEY(3)	Output control key for force in 3-direction (nodes J)		
KEY(4)	Output control key for moment in 1-direction (nodes J)		
KEY(5)	Output control key for moment in 2-direction (nodes J)		
KEY(6)	Output control key for moment in 3-direction (nodes J)		
KEY(7)	Output control key for force in 1-direction (node J)		
KEY(8)	Output control key for force in 2-direction (node J)		
KEY(9)	Output control key for force in 3-direction (node J)		
KEY(10)	Output control key for moment in 1-direction (node J)		
KEY(11)	Output control key for moment in 2-direction (node J)		
KEY(12)	Output control key for moment in 3-direction (node J)		
KN	Generation control key	[0,1]	0: No generation 1: Otherwise

Plate/Thin Shell Element Data

Control Information Data

ICODE(1)	Element type code	[3]	
ICODE(2)	Element group order number		
ICODE(3)	Total number of elements in the group for which output is requested		

Output Request Data

N	Element number		
KEY(1)	Output control key for force component $S_{x'x'}$		
KEY(2)	Output control key for force component $S_{y'y'}$		
KEY(3)	Output control key for force component $S_{z'z'}$		
KEY(4)	Output control key for moment component $M_{x'x'}$		
KEY(5)	Output control key for moment component $M_{y'y'}$		
KEY(6)	Output control key for moment component $M_{z'z'}$		
KN	Generation control key	[0,1]	0: No generation 1: Otherwise

Two-Dimensional Finite Element Data

Control Information Data

ICODE(1)	Element type code	[4]	
ICODE(2)	Element group order number		
ICODE(3)	Total number of elements in the group for which output is requested		

Output Request Data

N	Element number		
---	----------------	--	--

Table E.7: STRESS MODULE: Input Parameters (Cont.)

Input	Description	Options	Option Description
KEY(1)	Output control key for stress/strain in yy-direction		
KEY(2)	Output control key for stress/strain in zz-direction		
KEY(3)	Output control key for stress/strain in yz-direction		
KN	Generation control key	[0,1]	0: No generation 1: Otherwise
Three-Dimensional Spring Element Data			
Control Information Data			
ICODE(1)	Element type code	[7]	
ICODE(2)	Element group order number		
ICODE(3)	Total number of elements in the group for which output is requested		
Output Request Data			
N	Element number		
KEY(1)	Output control key for force in x-direction		
KEY(2)	Output control key for force in y-direction		
KEY(3)	Output control key for force in z-direction		
KEY(4)	Output control key for moment in xx-direction		
KEY(5)	Output control key for moment in yy-direction		
KEY(6)	Output control key for moment in zz-direction		
KN	Generation control key	[0,1]	0: No generation 1: Otherwise
Input Motion Data			
NFFT	Number of values to be used in the Fourier Transform		
NEQZ	Number of acceleration (or force) values to be read from cards		
DT	Time step (sec)		
EQMUL	Multiplication factor for scaling time history		