

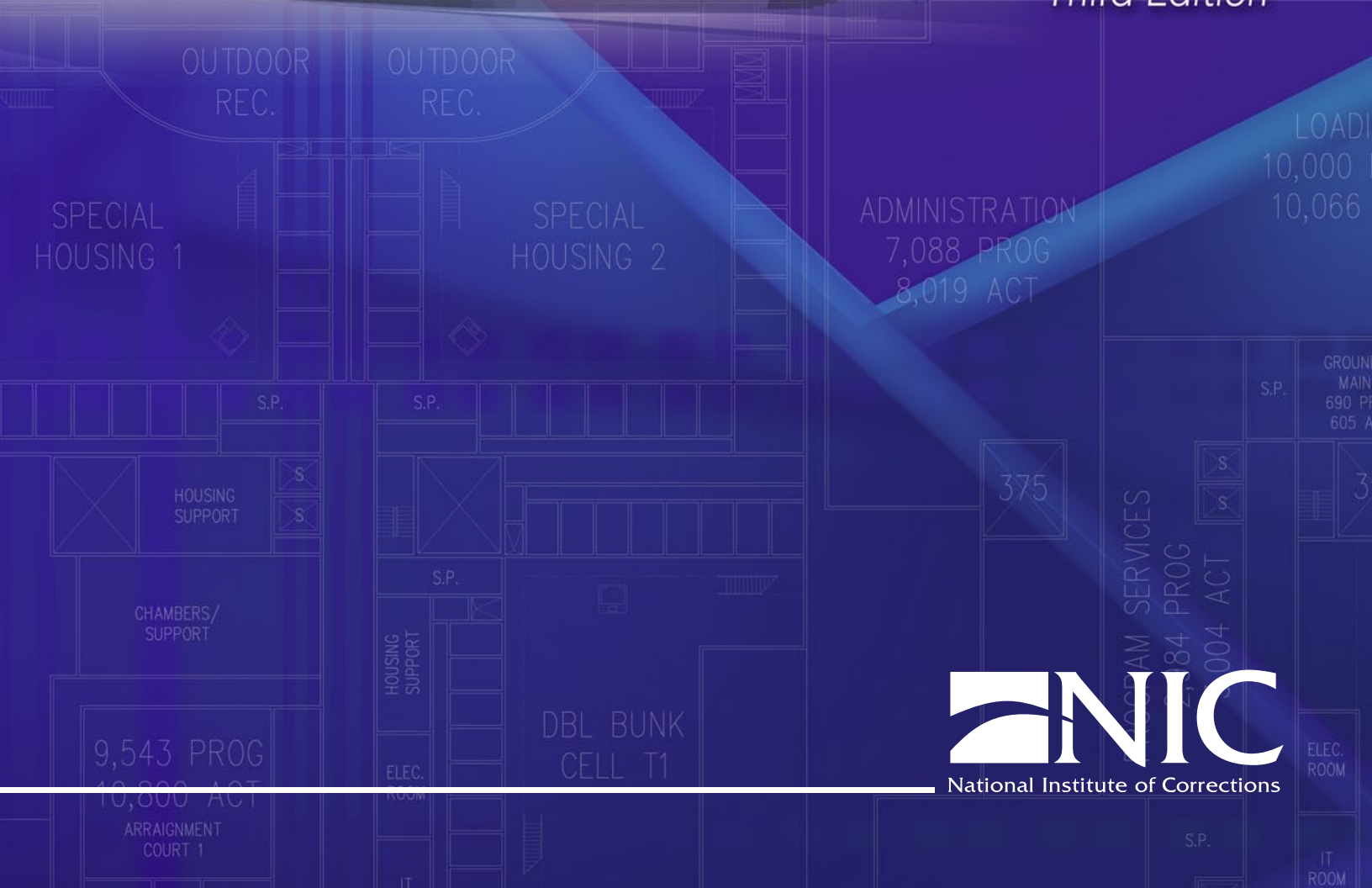

Jail Design Guide

Third Edition



**U.S. Department of Justice
National Institute of Corrections
320 First Street, NW
Washington, DC 20534**

Morris L. Thigpen
Director

Thomas J. Beauclair
Deputy Director

Virginia A. Hutchinson
Chief, Jails Division

Vicci Persons and Cheryl McKinney Paul
Project Managers

National Institute of Corrections
www.nicic.gov

Jail Design Guide

Third Edition

Dennis A. Kimme
Project Director

Gary M. Bowker
Associate Project Director

Robert G. Deichman
Project Staff

March 2011
NIC Accession
Number 024806



Table of Contents

Foreword	xix
Preface	xxi
Acknowledgments	xxv

SECTION 1. GETTING STARTED

Chapter 1. Introduction	3
Problems Overcome	4
Planning: A Key Component	4
About This Guide	4
Intended Audience	4
Organization	5
Smaller Jails	5
Note on Construction	5
Chapter 2. Predesign Planning	7
Why Plan?	7
Can a Prototype Replace the Need to Plan?	9
The Possibility of Reuse	9
Buyer Beware	10
Planning Steps	10
Phase 1: Project Recognition	11
Phase 2: Needs Assessment	11
Phase 3: Facility Program Development	12
Phase 4: Project Definition and Implementation Plan	12
Developing a Mission Statement	12
Learning More About Jails	13
Establishing Bed Capacity	13
Major Building Considerations	14
Option Development	15
When Planning Works Well	15
Planning to Plan	15
Who Does the Work?	16
How Long Does It Take?	16

SECTION 2. MAJOR DESIGN CONSIDERATIONS

Chapter 3. Site Selection and Design	19
Site Size	19
Building Area	19
Building Expansion	20
Parking	20

Table of Contents

Staff	20
Outdoor Spaces	22
Access to the Site and the Facility	22
Support Elements	22
Total Site Area	23
Site Location	23
Linkages	23
Surroundings	23
Views and Inmate Contact	24
Existing Jail Sites	25
Technical Requirements	26
Site Costs	27
Site Selection Process	28
Chapter 4. Image/Appearance	29
Exterior	29
Interior	29
Maintenance of Physical Security	30
Operations: Key to Normalization	30
Describing Desired Appearance	31
Chapter 5. Classification/Separation	33
Separation Problems	33
Inmate Types	33
Program Space Considerations	34
Cost of Housing for Different Inmate Types Versus Frequency of Need	34
Changes in Inmate Population	34
Surveillance/Supervision Method	34
Cell Occupancy	35
Classification Systems	36
When and Where Classification Occurs	36
Juveniles	37
Resolving the Numbers Problem in Smaller Jails: Multijurisdictional Options	37
Designing for Proper Separation	38
Inmate Types	38
Degree of Inmate Separation Required	38
Options for Housing Area Flexibility	40
Strengths and Weaknesses of Different Surveillance Methods	41
Use of Temporary Holding Cells	43
Use of Single-Occupancy Cells	43
Separate Housing of Work Release and Periodic-Sentence Inmates	43
Privacy Concerns	44

Chapter 6. Surveillance/Supervision	45
Methods of Surveillance/Supervision	45
Constant Staff Presence Required	45
Periodic Staff Presence Required	46
Design Considerations	46
Selecting Inmate Management and Supervision Modes	46
Staffing Versus Facility Durability	47
Remote Surveillance Design	47
Intermittent Surveillance Design	50
Direct Supervision Design	53
Electronic Surveillance Design	55
Nonhousing Surveillance	56
Chapter 7. Staffing Impact	57
Legal Issues	58
24-Hour Coverage	58
Possible Staff Types	59
Design Factors	59
Facility Location	60
Single-Level Versus Multilevel Design	60
Vertically Connected Posts	60
Inmate Separation	61
Surveillance/Supervision Methods	61
Circulation and Movement	62
Shared Activities	63
Security Perimeter	63
Emergency Response	63
Staff Backup	64
Designing Staff Workstations	64
Cell Occupancy	65
Electronic Monitoring Versus Staff Monitoring	66
Work Environment	66
Conclusion	66
Chapter 8. Security Perimeter	69
Ingredients of Security	69
Design Focus	70
Perimeters and Zones	70
Building Areas Outside the Security Envelope	71
Design Considerations	72
General Considerations	72
Main Security Envelope	74

Table of Contents

Perimeter Fences/Walls	79
Internal Security Zones	80
Conclusion	81
Chapter 9. Criminal Justice Interface	83
A General Caution	83
Law Enforcement Interface	83
Public/Staff Separation	84
Law Enforcement Dispatch and Jail Control in Small Jails	84
Records	85
Arrest Processing	86
Investigations and Lineups	86
Jail Administration and Staff	87
Food Service	87
Deliveries	87
Courts Interface	87
Corridor Movements	88
Movement to Offsite Court	88
Appearances at the Jail	88
Attorneys	89
Public Defenders	90
Probation/Parole	90
Conclusion	91
Chapter 10. Functional Components and Relationships	93
Jail Components	93
Degrees of Development	94
Food Service	94
Laundry Service	95
Component Relationships	96
Relationship Matrix	96
Relationship Diagram	96
Critical Relationships	96
Space-Sharing Possibilities	99
Special Housing	99
Indoor Programs and Services	100
General Housing in the Smaller Jail	100
Contact Visiting/Counseling	100
Indoor/Outdoor Recreation	101
Space-Sharing Problem	101
Conclusion	101

Chapter 11. Planning and Designing to Standards 103

State Standards 103

American Correctional Association and the Commission
on Accreditation for Corrections 103

National Fire Protection Association *Life Safety Code*® 105

Americans with Disabilities Act 105

 Location or Dispersion of Accessible Cells 106

 Basic Features of the Accessible Cell 107

 Furniture, Hardware, and Equipment 107

 Common-Use Areas 107

 Public and Staff Areas 107

Conclusion 108

Chapter 12. Expansion 109

Why Plan for Expansion? 109

Expansion Options 109

 Satellite Jail 109

 Double Bunking 110

 Planned Additions to the Jail 110

When To Develop an Expansion Plan 110

Setting Expansion Capacity 110

Vertical Versus Horizontal Expansion 110

 Potential Adverse Effects of Initial Design on Future Expansion 111

 Higher Initial Construction Cost 111

 Disruption to Facility Operations 111

Expansion Concept for Each Component 111

 Master Control 111

 Intake-Release 112

 Property Storage 112

 Health Care 112

 Visiting Areas 112

 Exercise Areas 112

 Programs and Services 112

 Inmate Commissary 113

 Food Service 113

 Laundry 113

 Lobby 113

 Administration Area 113

 Staff Areas 113

 Storage Areas 113

Conclusion 113

SECTION 3. FUNCTIONAL COMPONENTS

Chapter 13. Master Control 117

Key Decisions 117

Detail Issues 117

 Users 118

 Activities 118

 Security 119

 View 121

 Design Efficiency 122

 Environment 123

 Communication 124

 Equipment 124

 Fire Safety 125

 Expansion 125

Space List 125

Relationships and Components 126

Chapter 14. Intake-Release 127

Key Decisions 128

Detail Issues 129

 General Design 129

 Receiving (“Booking”) Area Design 133

 Arrestee Processing 137

 Admissions Area Design 143

 Release Area Design 145

Space List 146

Relationships and Components 147

Chapter 15. General Housing 149

Key Decisions 150

Detail Issues 151

 Basic Design Issues 151

 Sleeping Area Design Issues 162

 Dayroom Design Issues 167

 Miscellaneous Furniture and Equipment 168

 Inmates With Disabilities 168

 Staff Control Post Design 170

 Miscellaneous Design Issues 175

Space List 178

Relationships and Components 179

Chapter 16. Special Housing	181
Key Decisions	182
Detail Issues	182
Work Release/Periodic-Sentence Inmates	183
Inmate Workers	187
Protective Custody Inmates/Juveniles	187
Medical Isolation and Medical Housing	189
Disciplinary Detention/Administrative Segregation	192
Mental Illness/Suicide Threat/Intoxication	194
Space List	197
Relationships and Components	198
Chapter 17. Health Care	199
Key Decisions	200
Detail Issues	200
Examination Area	200
Medication Storage	205
Miscellaneous Issues	208
Space List	210
Relationships and Components	211
Chapter 18. Visiting Areas	213
Key Decisions	214
Detail Issues	215
Activities	215
Size of Spaces	215
Number of Visiting Stations	218
Location/Movement	218
Security	220
Quality	221
Space List	222
Relationships and Components	223
Chapter 19. Exercise Areas	225
Key Decisions	225
Detail Issues	226
General Issues	226
Combination Indoor and Outdoor Exercise	230
Indoor Exercise	231
Outdoor Exercise	232
Space List	234
Relationships and Components	234

Table of Contents

Chapter 20. Programs and Services	237
Key Decisions	237
Detail Issues	237
General Issues	238
Counseling	242
Religious Services	244
Library Services	245
Education	247
Recreation	248
Jail Industries	249
Space List	249
Relationships and Components	250
Chapter 21. Inmate Commissary	251
Key Decisions	251
Detail Issues	252
Size	252
Location	253
Equipment	253
Security	254
Communication	254
Space List	254
Relationships and Components	254
Chapter 22. Food Service	255
Key Decisions	256
Detail Issues	256
Food Service Provider	256
In-House Food Service	257
Location of Inmate Dining	258
Food Preparation and Storage	260
Cleanup and Waste Handling	261
Food Delivery	261
Staff Accommodations	262
Security	262
Inmate Workers	263
Staff Dining Area	263
Space List	264
Relationships and Components	264

Chapter 23. Laundry Area 265

Key Decisions 265

Detail Issues 265

 Laundry Provider 266

 Security Location 266

 Size 266

 Work/Storage 269

 Characteristics 269

Space List 270

Relationships and Components 270

Chapter 24. Administration and Public Areas 271

Key Decisions 272

Detail Issues 272

 Location/Arrangement 272

 Lobby/Reception 274

 Administrative Support Work Areas 277

 Administrator’s Office 279

 Conference Areas 280

 Security Equipment 281

Space List 282

Relationships and Components 283

Chapter 25. Staff Areas 285

Key Decisions 285

Detail Issues 286

 General Issues 286

 Locker/Shower Areas 286

 Physical Conditioning Area 289

 Break Room/Dining Area 290

 Training/Multipurpose Area 291

 Toilets 293

Space List 294

Relationships and Components 294

Chapter 26. Storage Areas 295

Key Decisions 295

Detail Issues 295

 Miscellaneous Storage Needs 295

 Overall Facility Storage Concerns 297

Table of Contents

Space List	301
Relationships and Components	302
SECTION 4. SPECIAL CONSIDERATIONS	
Chapter 27. Single Versus Multiple Occupancy	305
Definitions	305
Multiple Occupancy	305
Single Occupancy	306
Standards and Legal Issues	306
The Issue	307
Costs	307
Operational Concerns	308
Single-Occupancy Concerns	308
Costs of Multiple Occupancy	309
Double-Occupancy Single Cells	309
Conclusion	310
Chapter 28. Renovating Nonsecure Buildings Into Jails	311
A Common Renovation Example	311
Security Construction	312
Perimeter Issues	312
Interior Issues	313
Costs	313
Construction Costs.....	313
Operational Costs	315
Acquisition Costs	315
Conclusion	315
Chapter 29. Construction and Project Costs	317
Construction Costs	317
Project Cost	317
Project Cost Factors	318
Example	319
Conclusion	319
Chapter 30. Making a Building Work	321
Construction Monitoring	322
Policy and Procedure Development	322
Final Staffing Plan and Staff Post Orders	323
Staff Recruitment and Selection	323
Staff Training	324
Move Logistics	324
Summary	325

List of Exhibits

- Chapter 2. Predesign Planning**
 - 2-1. Distribution of Project Costs8
 - 2-2. Phases of Predesign Planning 11
 - 2-3. Daily Counts and Average Annual Population 14
 - 2-4. Typical Allocation of Time for Predesign Planning 16
- Chapter 3. Site Selection and Design**
 - 3-1. Typical Irregular Shape of Jail20
 - 3-2. Multiple Parking Areas 21
 - 3-3. Common Facility Access Points 22
 - 3-4. Window Sill Height Above Floor Level Prevents View Conflict24
 - 3-5. Placement of Window To Look Out Onto Controlled Space25
- Chapter 5. Classification/Separation**
 - 5-1. Remote Surveillance Housing Unit 35
 - 5-2. Intermittent Surveillance Housing Unit 35
 - 5-3. Using a Storage Area To Buffer Sound 39
 - 5-4. Program Area Located Between Housing Units for Sight and Sound Separation 39
 - 5-5. Special Management Area in a Smaller Jail 40
- Chapter 6. Surveillance/Supervision**
 - 6-1. Direct Supervision Housing Unit 45
 - 6-2. Intermittent Surveillance 46
 - 6-3. Remote Surveillance Housing Pod 47
 - 6-4. Placement of Control Stations To Prevent Unwanted Views Between Inmates 48
 - 6-5. Preferred Placement of Fixed Posts 49
 - 6-6. Traditional Back-to-Back Cellblocks 51
 - 6-7. Inmate View Conflict 52
 - 6-8. Entry Pocket To Prevent Inmate View Conflict 53
 - 6-9. Three-Dimensional Overhead View of Direct Supervision Housing Pod 53
 - 6-10. Colocation of Essential Daily Functions With Housing in a Direct Supervision Unit 54
 - 6-11. Blind Corner 55
- Chapter 7. Staffing Impact**
 - 7-1. Average 30-Year Life Cycle Costs 57
 - 7-2. Stairway for Vertical Connection Between Multilevel Posts 61
 - 7-3. Simplified Circulation Corridor 62
 - 7-4. Evacuation Routes 64
- Chapter 8. Security Perimeter**
 - 8-1. Secondary Internal Security Zones 71
 - 8-2. Relationship of Overall Building to Main Security Perimeter 71
 - 8-3. Security Ceiling 74
 - 8-4. Security Vestibule 75
 - 8-5. Visiting Area in Relationship to Main Security Perimeter 78



List of Exhibits

Chapter 9. Criminal Justice Interface

9-1. Separation of Public From Nonpublic Areas	85
9-2. Location of Master Control and Communications/Dispatch Operations Relative to Jail and Law Enforcement Areas and Public Lobby	85
9-3. Provisions for Arresting Officers	86
9-4. Inmate Waiting Area Adjacent to Attorney-Client Visiting Rooms	90

Chapter 10. Functional Components and Relationships

10-1. Catered Food Service	95
10-2. Relationship Matrix	97
10-3. Relationship Diagram	98
10-4. Relationship of Work Release Area to Other Inmate Areas	98
10-5. Recreation Area That Can Be Used for Both Indoor and Outdoor Space	101

Chapter 11. Planning and Designing to Standards

11-1. Layout of an Accessible Cell	107
--	-----

Chapter 13. Master Control

13-1. Entry to Secure Perimeter Doubles as Secure Entry to Master Control	121
13-2. Master Control Position Expected To Observe Too Many Things	121
13-3. Floor Height of Master Control Raised Above Dayroom and Corridor	122
13-4. Preferred Control Panel Configuration	123
13-5. Master Control Component Diagram	126

Chapter 14. Intake-Release

14-1. Intake-Release Area	127
14-2. Detailed View of Intake-Release Area in a Smaller Jail	132
14-3. Vehicle Sallyport Showing Drive-Through Design	134
14-4. Vehicle Sallyport Showing Floor Area Configuration	135
14-5. Pedestrian Entry Vestibule	136
14-6. Secure Pedestrian Entry Vestibule	136
14-7. Visiting Area	141
14-8. Release Area Design	145
14-9. Relationships Between Receiving and Admissions Areas	147
14-10. Components of Booking Area	147

Chapter 15. General Housing

15-1. Unobstructed Views of Two Tiers of Cells	155
15-2. Emergency Exit Stair for Second-Tier Egress	155
15-3. Examples of Variations in Design Approach	157
15-4. Use of High, Small Windows and Skylights	158
15-5. Use of Clerestory Window To Introduce Light Into Interior Cells	159
15-6. Fire Zones	161
15-7. Comparison of Space Needed for Combination Fixture Versus Separate Toilet and Sink	164
15-8. Options for Exposure of the Face of the Cell	166
15-9. Configuration of Dayroom in Two-Tiered Housing Unit	168

15-10. Dayroom Table With Swing-Out Seat To Accommodate Wheelchair	169
15-11. Remote Observation Control Post	171
15-12. Vertical View in Two-Tier Housing Obscured by Single-Level Vestibule	174
15-13. Sizing of Security Vestibule To Allow for Door Swings and Passage of Equipment	176
15-14. Relationships Between Housing Unit Space Components	179
15-15. Component Diagram of a Typical Cell	179
Chapter 16. Special Housing	
16-1. Privacy Partition in Sleeping Area	183
16-2. Direct Line of Sight Into Sleeping and Dayroom Areas	184
16-3. Entry/Exit for Work Release/Periodic-Sentence Inmates	185
16-4. Entry Sequence for Work Release/Periodic-Sentence Inmates	185
16-5. Door in Dayroom Partition	188
16-6. Secondary Access to Cell	188
16-7. Security-Related Spatial Affiliations in Medical Housing	192
16-8. Relationships Between Special Housing Areas and Other Jail Areas	198
16-9. Components of Work Release Unit	198
16-10. Components of ADA-Compliant Cell	198
16-11. Components of Suicide/Mental Health/Detoxification Observation Cell	198
Chapter 17. Health Care	
17-1. Access Around Examination Table	203
17-2. Examination Room Designed for Natural Light	205
17-3. Medication Storage Area	206
17-4. Possible Locations of Medication Storage Area	207
17-5. Relationships in Health-Care Area	211
17-6. Component Diagram of Health-Care Area	211
Chapter 18. Visiting Areas	
18-1. Single and Double Visiting Stations	216
18-2. Sample Visiting Assumptions	218
18-3. Moving the Inmate to the Visitor	219
18-4. Secure Visitor Corridor Constructed Above the Primary Inmate Corridor	219
18-5. Security Vestibule in Visiting Area	221
18-6. Relationships Between Visiting Area and Other Jail Areas	223
18-7. Components of Visiting Areas	223
Chapter 19. Exercise Areas	
19-1. Sample Exercise Space Needs	227
19-2. Centrally Located Exercise Yard	229
19-3. Exercise Area Monitored by Staff Who Monitor Other Areas	229
19-4. Exercise Areas Immediately Adjacent to Housing Units	229
19-5. Outdoor Exercise Area Surrounded by Building	233
19-6. Emergency Refuge Area	234
19-7. Relationships Between Exercise Areas and Housing and Public Areas	234
19-8. Components of Indoor and Outdoor Exercise Areas	235

List of Exhibits

Chapter 20. Programs and Services

20-1. Storage Space Adjacent to Multipurpose Area	240
20-2. Counseling Rooms Adjacent to Multipurpose Area	242
20-3. Use of Shutters To Provide Privacy in a Contact Visiting/Individual Counseling Area Not Associated With Multipurpose Space	242
20-4. Altar Area That Can Be Closed Off During Nonreligious Activities	245
20-5. Area Requirements for Different Activities	249
20-6. Relationship of Programs/Services Area to Housing and Lobby	250
20-7. Components of a Programs/Services Area	250

Chapter 21. Inmate Commissary

21-1. Commissary Adjacent to Multipurpose Area	253
21-2. Relationship of Commissary to Housing and Multipurpose Areas	254
21-3. Commissary Components	254

Chapter 22. Food Service

22-1. Centralized Dining Area Adjacent to the Kitchen	258
22-2. Production Flow for Food Preparation	260
22-3. Jail Delivery Vestibule/Loading Dock	262
22-4. Relationship of Food Service Area Components	264
22-5. Sample Food Service Area	264

Chapter 23. Laundry Area

23-1. Location of Separate Laundry Facilities for Work Release Inmates	267
23-2. Relationship of Laundry Components	270
23-3. Sample Laundry Area	270

Chapter 24. Administration and Public Areas

24-1. Administration Area in Relationship to Security Perimeter	273
24-2. Secure Reception Area	276
24-3. Jail Administrator's Office	280
24-4. Assumptions for Size of Conference Area	281
24-5. Relationship of Administration Area to Jail Operations and Public Lobby	283
24-6. Components of Administration Area	283

Chapter 25. Staff Areas

25-1. Lockers Elevated on a Base	289
25-2. Use of Folding Partition in Staff Multipurpose Room	293
25-3. Relationships Between Staff Areas and Security Perimeter	294
25-4. Physical Conditioning and Locker/Shower Areas	294

Chapter 26. Storage Areas

26-1. Relationships Between Miscellaneous Storage Areas and Other Jail Components	302
26-2. Central Storage Area	302

Chapter 27. Single Versus Multiple Occupancy

27-1. Sample Floorplan of Dormitory-Style Multiple-Occupancy Housing 306

27-2. Sample Floorplan of a Single-Occupancy Cell 306

27-3. Sample Floorplan of a Single-Occupancy Cell Showing Unencumbered Floorspace 307

27-4. Square Footage Requirements for Double and Single Cells Based on
American Correctional Association Performance-Based Standards for Local
Adult Detention Facilities 310

Chapter 28. Renovating Nonsecure Buildings Into Jails

28-1. Hospital Wing With Poor Views of Rooms and Lack of Dayroom Space 311

28-2. Comparison of a Typical Hospital Wall With a Typical Jail Wall 312

28-3. Jail Costs by Construction Component 314

28-4. Jail Shell Costs 314

28-5. Cost Analysis of Renovation That Requires Addition of One Staff Post 316

Chapter 29. Construction and Project Costs

29-1. Total Project Cost 317

29-2. Hypothetical Project Budget 319

Foreword

New jail construction is a major capital undertaking that often represents the single largest project in which county officials will ever be involved. Many local jurisdictions are replacing outdated facilities as well as expanding bedspace to accommodate increasing numbers of inmates. The U.S. Department of Justice, Bureau of Justice Statistics, reports that as of June 2008, the total rated capacity of the nation's jails was 813,502 beds, up from an estimated 677,787 beds at midyear 2000 (an average increase of 2.6 percent per year).¹

To respond to local jurisdictions' need for assistance in jail planning and design, the National Institute of Corrections offers the Facility Development Process that provides guidance as jurisdictions proceed with jail planning, design, construction, and transition. This guide supports the Facility Development Process by providing information about basic concepts and issues surrounding jail design.

The *Jail Design Guide, Third Edition*, is a revised and expanded version of the original *Small Jail Design Guide* published in 1988. It now includes specific information relevant to planning not only for small jails but information that can be used for planning jails of any size. Based on information from correctional practitioners and the authors' analysis and experience, the document discusses current correctional standards and architectural principles that are important to building a cost-efficient jail to meet a locality's particular needs. While plainly written, it is sufficiently technical and detailed to guide local officials, architects, and planners who may be unfamiliar with jail design, construction, and operational issues. It does not, however, include sample floor plans, as that would imply the recommendation of model solutions to jail planning and design issues. Each jurisdiction needs to craft a jail design to meet its unique situation and community needs.

The information presented here will be beneficial to anyone involved in the planning, design, and construction of a new jail: sheriffs, county commissioners, jail administrators, directors of corrections, criminal justice planners, and interested citizens. The *Jail Design Guide* can help local officials assume and retain control of this important process and direct it toward the most beneficial solution for their community.

Morris L. Thigpen

Director

National Institute of Corrections

¹ William J. Sabol and Todd D. Minton, *Jail Inmates at Midyear 2007* (Washington, DC: U.S. Department of Justice, Office of Justice Programs, Bureau of Justice Statistics, 2008), <http://bjs.ojp.usdoj.gov/content/pub/pdf/jim07.pdf>, accessed June 9, 2010.

Preface

This third edition of the *Jail Design Guide* is, as was its predecessor, an information resource intended to help jurisdictions design better and more effective jails. Whereas the original publication targeted small jails—then defined as those with 50 or fewer beds—and the second edition targeted both small and medium-sized jails, this edition provides general information for those designing jails of any size, as well as specific information for smaller jails.

The focus of what is now simply entitled the *Jail Design Guide, Third Edition* was broadened for two reasons:

- Increases in local jail populations have significantly reduced the demand for new jails of only 50 or fewer beds.
- Reflection and feedback on the previous editions have made it clear that most of the issues raised in the original document apply equally to jails of any size.

This publication provides the reader with information concerning the important elements and concepts of successful jail design. Although it has been redefined as a design guide for all jails, the *Jail Design Guide, Third Edition*, recognizes that there are some fundamental differences between small/medium-sized jails and large jails or systems of facilities found in major metropolitan areas. These fundamental differences exist in many areas, a key one being the challenge of designing to accommodate the separation of inmates with various classification and security needs. Large systems can respond to this issue by devoting entire housing pods, or even separate facilities, to different classifications while still maintaining staff efficiency. The response in smaller facilities is more complicated and calls for different answers. The techniques used to design for the separation of inmates by classification needs are the subject of considerable discussion in the *Guide*, as are many other special design challenges that result from constructing a facility of lesser scale and more limited resources.

The *Guide* avoids re-creating information that already exists in other areas of importance to jurisdictions in the process of designing a new jail. Specifically, it does not present detailed information on the predesign planning process, inmate supervision approaches, or staff training and needs analysis because other excellent resources on these topics already exist. However, because these and other so-called nondesign issues so greatly affect design, their influence is acknowledged throughout this publication. One of the main principles of the *Jail Design Guide, Third Edition*, is that planning and operational issues cannot be separated from design and, in fact, shape the design of every facility.

Background

Problems Recognized

The primary incentive for developing the original *Small Jail Design Guide* (1988) was that staff of the Jails Division at the National Institute of Corrections (NIC), as well as other professionals in the field, became increasingly aware that some very ineffective and outdated small jails were being designed and built. These facilities came to NIC's attention because design flaws created many management problems and political controversies for the owners and operators. These problems generated numerous technical assistance requests to NIC, and it was often the case that little could be done to correct major flaws in the architecture of something as permanent as a jail.

NIC staff quickly realized that there were additional reasons to pay special attention to small jails. Small jails represented the majority of the jail facilities in the United States; however, very little of the research and literature was really applicable to the small jail. NIC staff also realized that even though small jails are obligated to meet most of the same requirements as large jails, they typically have far fewer resources with which to address their problems and often less access to information to enable their administrators to make informed decisions. In addition, there were problems unique to small jails that were not problems for large jails, simply because of differences in scale.

NIC Response

Instead of continuing to react to small jails' requests for assistance, NIC adopted a proactive approach to help them recognize and address the issues they face. To fill the information void surrounding small jails, NIC initiated the Small Jails grant program in 1984.

The Small Jails program began with an evaluation of new county jails with a capacity of 50 or fewer beds that had opened since 1974. The evaluation was designed to find out what worked in small jail design and what did not and to identify operational problems related to design in these facilities.

The evaluation identified some successful facilities and operations but also confirmed that there were indeed serious and widespread problems in the design and operation of recently built small jails. In some cases, these problems were unsolvable, and in others they were manageable. Most disappointing was that many traditional problems of small jails were being repeated in ways that were irreversible short of major renovation.

The original *Small Jail Design Guide* attempted to provide jurisdictions with information that would help in the planning of new jail facilities to avoid past design problems. It represented the last publication in a series of products that addressed this general goal by documenting and applying the lessons learned from the initial evaluation work with small jails. Preceding the *Small Jail Design Guide*, NIC released two publications that were direct products of the small jails evaluation: *The Nature of New Small Jails: Report and Analysis* (1985) and *Small Jail Special Issues* (1986). These are companion pieces to the original *Small Jail Design Guide* and the revised *Jail Design Guide: A Resource for Small and Medium-Sized Jails* (1998). Although these documents were published many years ago, many of the issues discussed in them are still applicable to small jails and may also apply to medium-sized jails.

The Third Edition

The *Jail Design Guide, Third Edition* retains the basic purpose, organization, and content of the first two editions. It updates the second edition by:

- Including information affected by current standards and codes.
- Expanding the information provided so that it is equally relevant to small, medium, and large jails. Sidebars were added for information that is significant to smaller jails, but not necessarily to larger jail facilities.

- Adding revised material that broadens and sharpens the document’s contents.
- Revising graphics and substantially increasing the number of photos from actual projects.

The information presented in this publication is based on lessons from experience—ideas and concepts that have been found to work for jurisdictions faced with the challenge of building a new jail facility. The information also focuses, to a significant, but lesser degree, on what has not worked. Consequently, it is hoped that through use of the *Jail Design Guide, Third Edition*, some of the lessons learned by others will benefit jurisdictions about to enter their own planning and design process. In this way, users of this publication can move one step closer to creating safe, secure, and lasting facilities.

Acknowledgments

The project team is indebted to the National Institute of Corrections (NIC) for the opportunity to revise and update the *Jail Design Guide: A Resource for Small and Medium-Sized Jails* (1998), which was a revision of the *Small Jail Design Guide* (1988). The original *Guide* was a large and complicated undertaking, but one that provided its authors with many rewards based on its documented value to planning professionals and local officials alike. Without NIC's *Small Jail Design Guide* or the subsequent *Jail Design Guide*, they would have been without a substantial planning and design resource as they undertook major projects involving millions of dollars in construction and jail staff time.

The project team is still enormously indebted to Michael O'Toole, former NIC Jails Division Chief, for his stewardship of this complicated and lengthy project. His patience, professionalism, and commitment to a quality end-product were a major driving force during the course of the original and second edition work. Thanks also to Tom Reid, NIC Project Monitor at the second edition's conclusion, for his review assistance and guidance, and to Nancy Sabanosh, former NIC Publications Manager, for her superb editorial and production assistance on the original two efforts. Additional thanks to James R. Rowenhorst, corrections specialist, and David E. Bostwick, architect, for their contributions to this document.

We greatly appreciate the enthusiasm, support, and direction provided to us on the third edition work by our NIC project manager, Correctional Program Specialist Vicci Persons. Vicci's continued belief in the value of the *Jail Design Guide* was gratifying and inspirational. We would also like to thank Voorhis Robertson Justice Services, Jim Rowenhorst, and Liebert & Associates for providing new photographs for the *Guide*.

At the Kimme & Associates' office, Sue Van Matre's attention to endless revisions through all three publications is greatly appreciated.

Finally, recognition must again go to many current and former NIC Jails Division staff who invested considerable time in reviewing and improving the document, and to the many superb people in the field who completed the surveys behind the original research for the project and hosted research visits by the project team.

Dennis A. Kimme

Chapter 1. Introduction 3

Chapter 2. Predesign Planning 7

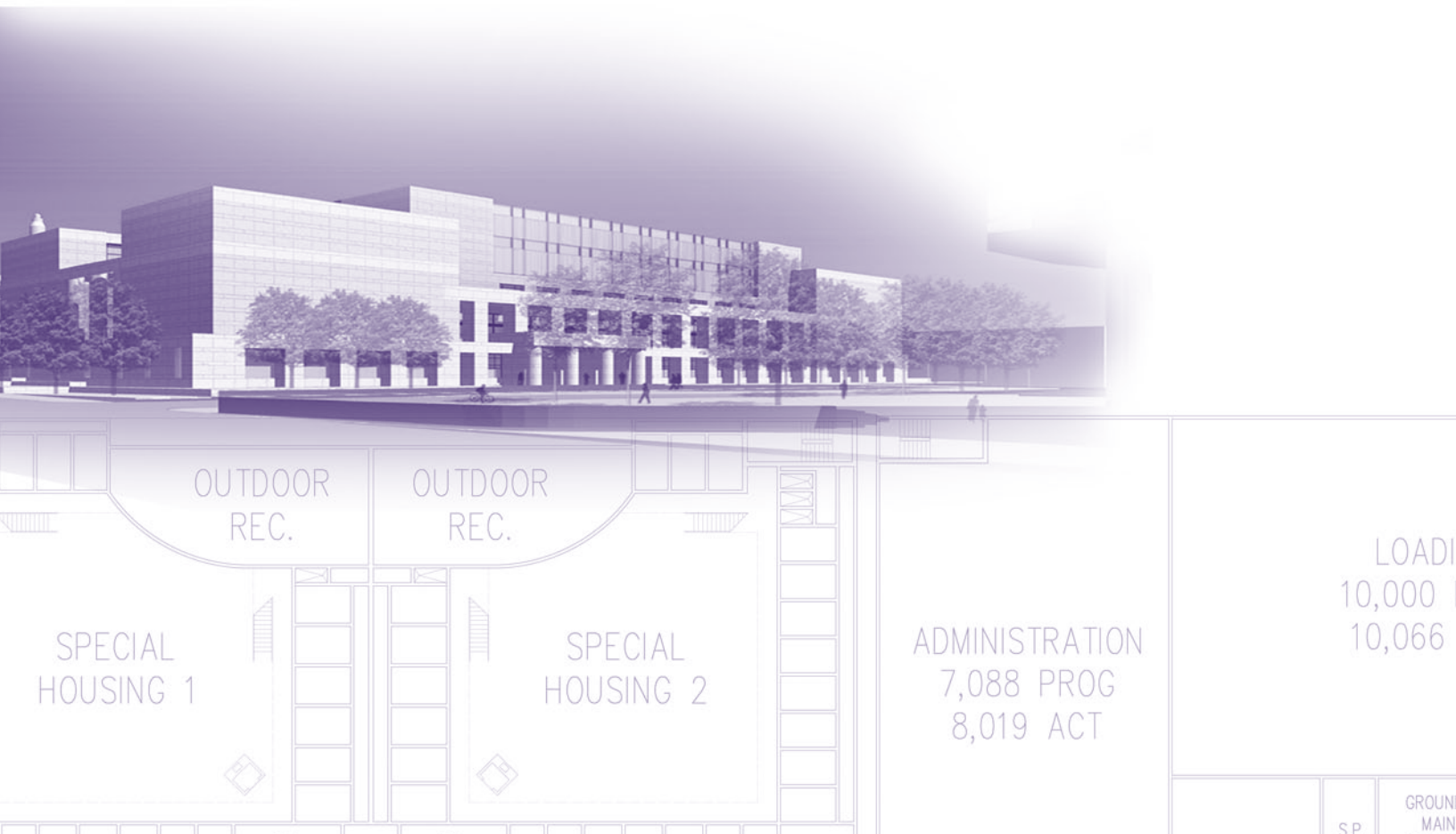

The opening statement of the preface to this guide identifies its purpose as one of helping to create “better” and “more effective” jails. Because such terms can mean different things to different people, they should be defined.

The findings of the original small jails research indicated that better, more effective jails are fundamentally those that satisfy the basic needs of their occupants, users, and owners for safety, security, effective inmate management, and efficiency. More specifically, evaluations of old and new jails throughout the country suggest that the following minimum operational and architectural characteristics are essential to attaining a better, more effective jail.

Operational characteristics:

- Staff that are well trained in jail operations and inmate management.
- Adequate and efficient staffing, including around-the-clock jail staff and female staff on duty when women are housed in the facility.
- Existence of written policies and procedures to guide operations and facilitate training.
- Constant surveillance or supervision of inmates, as opposed to intermittent observation.
- Inmate programs and amenities that can be used to influence positive inmate behavior and alleviate idleness.
- Existence and fair application of inmate rules and disciplinary procedures.
- Sufficient operational funding available prior to the opening of the new facility.

Architectural characteristics:

- Adequate capacity, including the right kinds of bedspace to allow proper inmate classification and separation, and flexibility in the use of housing areas.
- Good lines of sight and visibility of housing areas.
- Cell and dormitory occupancy levels appropriate to the inmate classification.
- Control of sound levels and elimination of visual conflicts.
- An appropriate physical environment (space, temperature, light, color, humidity) for inmates to live in and for staff to work in.
- Minimum need to rely on electronic surveillance, especially closed-circuit television.
- Spatial organization that accommodates the flow of activities rather than inhibits it.
- Ample storage.
- Adherence to some form of recognized standards.
- Ability to expand the facility in terms of both capacity and support services.
- Ability to maintain the facility through the use of local service personnel and the purchase of locally available parts and equipment, wherever possible.

Although these operational and architectural characteristics may seem obvious to many readers, many jails fail to realize them. Some jails lack even the most rudimentary of these design characteristics and are considered architectural

disasters by their owners. Poor design can result in expensive mistakes laden with financial and political costs that can haunt local officials for years to come.

Problems Overcome

Generally, jails with the characteristics outlined above have overcome or minimized some traditional problems:

- Accommodation of small and special inmate populations, such as women and inmates who are intoxicated, present behavioral problems, or require special management (i.e., mental health or medical treatment).
- Assaults against staff and inmates.
- Suicides and suicide attempts.
- Fires.
- Vandalism.
- Lawsuits.
- Contraband passage.
- Standards compliance.

Planning: A Key Component

One key component to a better and more effective jail is comprehensive predesign planning. Jail evaluations and practical experiences clearly demonstrate that jurisdictions that take the time to plan before they design and to determine what they need before they authorize the architect to proceed with design have fewer operational and facility problems when the facility is complete. Local governments that do the predesign work necessary to learn and apply the characteristics of better, more effective jails can achieve a greater degree of satisfaction and efficiency with their new facilities.

Besides achieving the characteristics cited above, jurisdictions that did comprehensive predesign planning also improved their architectural designs in the following areas:

- Circulation patterns in the jail.
- Placement of rooms within the facility.
- The right types and number of rooms.
- Adequate space for inmates, staff, and support services.
- Environmental quality.
- Durability of materials and hardware used.
- Proper sightlines into and within inmate housing areas.

These are all fundamental and necessary attributes of a successful jail facility design.

About This Guide

Good planning involves identifying users and activities, and good design is clearly measured by the degree to which a building conforms to the needs and activities of the people who will use and live in the facility. To borrow an old phrase, good jail design is based on the premise that “form follows function.”

The approach taken in this design guide is informed by the findings of the original small jails research, subsequent feedback on the original design guide, and the authors’ two and a half decades of practical experience regarding the importance of planning to attaining successful design.

Intended Audience

The primary readers of this document will be the people who operate and design jails. Other local

officials such as county commissioners, judges, and prosecuting attorneys will also likely find elements of this publication useful and informative. Those involved in the design of a new jail, regardless of their role and regardless of the facility's size, should find the *Jail Design Guide, Third Edition* to be a helpful resource.

Organization

The *Jail Design Guide, Third Edition* presents information in a format designed to be easily used by the reader. It is organized in four sections:

- **Section 1, Getting Started.** The first section of the *Guide* comprises chapter 1—the present introduction—and chapter 2, “Predesign Planning.” Although this publication is not intended to be a “how-to” guide on jail planning, comprehensive predesign planning is, as noted above, fundamental to achieving a better, more effective jail. Therefore, before embarking on the examination of design considerations and functional components, the *Guide* discusses the process of predesign planning, and identifies the characteristics of good predesign planning in relation to its influence on architectural design. Planning considerations that affect design also are noted throughout the *Guide*.
- **Section 2, Major Design Considerations.** Chapters 3–12 identify the major considerations that shape the overall approach to the design of the jail: site selection and design, image/appearance, classification/separation, surveillance/supervision, staffing impact, security perimeter, criminal justice interface, functional components and relationships, planning and designing to standards, and future expansion. These considerations relate to the fundamental operational and security decisions that are made during predesign planning.
- **Section 3, Functional Components.** Chapters 13–26 present detailed information about various functional components of a facility—master control, intake-release, general housing, special housing, health care, visiting areas, exercise areas, programs and services, the inmate commissary, food service, laundry areas, the administration area and public lobby, staff areas, and storage areas—in the context of the design considerations identified in section 2.
- **Section 4, Special Considerations.** Chapters 27–29 address design and construction issues that have caused difficulty or controversy in jurisdictions throughout the country. Chapter 30 concludes the *Guide* with a discussion of issues related to the transition to the new jail, specifically, the key activities (e.g., the development of policies and procedures for the new facility, master scheduling, staff training) that must take place during the construction phase to make a facility an operational success.

Smaller Jails

Although the *Guide* provides general information for use by any jurisdiction designing a new facility, it still specifically addresses issues faced by smaller jails. Information pertaining to small jails is flagged with the following icon:



Note on Construction

This *Guide* does not address architectural construction details to any great extent. Although this may disappoint some readers, construction details are excluded for several reasons, not the least of which is the wish to avoid creating an overly lengthy and complex document. Also, the authors want to encourage rather than limit local

**Section 1:
Getting Started**

involvement, learning, and choice in the detail development of individual facilities.

The goal of this document is to provide direction and assistance, not to act as a substitute for local efforts and decisionmaking. Providing detail and specific material recommendations could well stifle creativity and the search for answers proper to the widely varying needs of jurisdictions

across the United States. Also, trying to deal with the full range of detail issues could easily lead to the unintended exclusion of alternative materials and hardware. Consequently, this document is limited to the major design questions and influences affecting jails, leaving owners, architects, and engineers to develop proper detail, hardware, material, and equipment responses to larger design issues.

Chapter 2

Predesign Planning

Many communities fail to recognize the value of and need for predesign planning. Once they acknowledge that construction of a new jail facility is unavoidable, they frequently want to move quickly to a solution. Hiring an architect to start drawing plans, buying a prototype design, or signing a design-build contract on the strength of a budget and bed need estimate can seem to be the most expeditious choice for many communities.

Unfortunately, jails designed without adequate predesign work often experience problems after the facility opens. The facility may be too small and quickly become crowded, or it may be large enough but too expensive to operate. Important design features may have been left out, such as the ability to see into inmate living areas from a single control point or to move easily through the building. The facility may not allow for appropriate inmate classification and separation requirements, resulting in failure to comply with standards and vulnerability to litigation. Support spaces may be inadequate or missing altogether. The building may lack important equipment or functional areas, and/or may use furniture and equipment prone to wear and breakage. The completed building may be nothing like local officials imagined or what the public expected for its tax dollars. Once these faults are discovered, in something as permanent and visible as a jail, they tend to be thorns in the side of local officials for many years.

Jurisdictions that simply “buy a jail” leave out an essential part of the facility development process: predesign planning, that is, the work that needs to be done before the architect can start a design. This early planning work is needed to answer a number of critical questions:

- How many beds should the jail have? How many inmates will it hold when it opens and further into the future?
- How many and what types of inmates will need separation from others?
- How will inmates be supervised?
- What are the options in terms of renovation, addition, or new construction?
- How should the jail interrelate with other criminal justice functions?
- What programs and services will the jail provide, and to what extent?
- How many staff will be needed?
- What kinds of spaces should be in the jail? How big should they be? How should they be arranged?
- How much and what type of expansion capability should be built into the facility design?
- How much will it cost to build and operate a jail?

Although it is not the purpose of the *Jail Design Guide, Third Edition* to be a complete predesign planning resource, planning is extremely important to the jail design process and merits a brief review of its nature and impact.

Why Plan?

Planning takes time, effort, and money. Why should a jurisdiction bother with this involved and detailed process, rather than go ahead and build a new jail? Aren't all jails the same? Here are some reasons for local jurisdictions to commit to, and be involved with, the predesign process:

Section 1: Getting Started

- The predesign process provides an opportunity for jurisdictions to evaluate their inmate population as to who they are incarcerating, why they are incarcerating them, and how they can better manage this population.
- As jail populations continue to grow, the planning process is an opportunity for jurisdictions to conduct a thorough evaluation of capacity reduction measures, such as pre- and posttrial alternatives to incarceration for low-risk offenders. This is an opportunity for all aspects of the criminal justice system (e.g., courts, district attorney, jail, law enforcement, probation) to work together to develop a criminal justice plan for the entire system.
- The process allows existing jail staff to have input into the facility development process. Their operational experience is invaluable, and their early participation ensures they develop ownership in the process.
- This may be the only chance during an official's lifetime to influence the direction of a facility that should last at least 30 or 40 years. In some ways, design has less impact than predesign planning, where the really big decisions are made.
- Planning allows local officials to take control of the process and ensure that the jail built is what is needed and wanted rather than what someone else thinks is needed or wanted. This is an opportunity for officials to educate themselves on what they will need to do to design, build, and operate a jail that meets the needs of their jurisdiction.
- Planning is a vehicle for gaining broad political and public support for the project. It can help prevent the project from being vetoed when it comes to getting the money needed to build.

- Money-saving ideas, which might not come up during design, can be considered in this phase. Examples are the creation of nonjail programs (saving beds) or contracting for food and laundry services instead of paying for expensive staff, space, and equipment.
- The architects or design-builders, no matter how experienced in jail design, will not truly know what to design to meet a jurisdiction's needs without planning information provided by the jurisdiction. Consequently, they will have to design according to their view of what a jail should be, rather than the client's view, and may well miss features important to local operations.
- The costs of predesign planning are negligible compared with the costs of designing, constructing, and operating a jail, particularly one that is ill-suited to local needs (exhibit 2-1). Yet it is the most influential step in the creation of future facilities and operations. Predesign planning usually costs roughly half of 1 percent of total project costs.

Because of the money and liabilities involved in building and operating a jail, local officials owe it to their constituents and themselves to consider the critical issues that predesign planning is intended to resolve, rather than prematurely jumping into design, buying prototypes, or initiating a design-build process.

Exhibit 2-1. Distribution of Project Costs

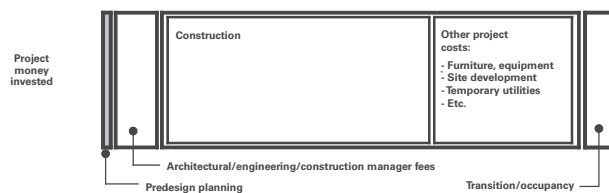

Can a Prototype Replace the Need to Plan?

Local officials, and sometimes the public, frequently express the opinion that all jails are alike—or that they cannot be that much different—so why bother with planning? Why not just use someone else’s design, why not just buy a prototype, to save time and money?

Every community is unique and has different problems, but many have at least one common problem: their jail is crowded or antiquated and they need a new or expanded one. Although all jails have cells and need support service space—administrative offices, a lobby, a booking area, food service, laundry, program areas, mechanical rooms, and storage—these commonalities rarely lead to an identical description of facilities needed by different communities. Many variables change the exact way in which people solve their problems, thus leading away from prototypes. For example, each local jurisdiction may have different:

- Jail standards (these can vary widely from state to state).
- Building and life safety codes.
- Jail site characteristics (e.g., size, shape, elevation, soils, water tables, flood plain).
- Physical relationships to the courthouse and other services (e.g., on same site, across the street, remote).
- Budgets.
- Climates.
- Bed capacity and expansion needs.
- Mixes of inmate populations.
- Ideas regarding facility design/management concepts (e.g., direct supervision versus intermittent surveillance).

- Technology needs.
- Qualities of architectural detailing and engineering systems (e.g., mechanical, electrical, plumbing).
- Correctional philosophies and public attitudes.
- Operational policies and procedures (some dictated by law).
- Availability of qualified staff (ranging from low-paid and poorly educated to highly paid and highly educated).

All of these considerations tend to interact in ways that diminish the likelihood that a jail design appropriate for one community can be successfully used in another.

The Possibility of Reuse

In spite of the issues raised above, it does seem theoretically possible to find a building plan that would exactly fit a community’s needs. It is, however, more likely that specific parts of a prototype might meet those needs. To accommodate the differences, adjustments to the prototype would have to be made. Once adjustments to a prototype are needed, a community may have the worst of both worlds: adapting most of its needs to someone else’s solution while absorbing nearly the full price of design after purchasing the drawings and paying for plan adjustments.

To prove that an existing plan could work, a community would be advised to at least “program-in-reverse.” That is, a team of community representatives, composed of jail staff, the sheriff, county board members, facility operations staff, and others, should visit the prototype facility being considered and spend considerable time there evaluating the following elements in detail:

- All of the spaces and how those spaces work.
- The staffing required by those spaces.

Section 1: Getting Started

- The building's construction and its compliance with current codes and standards.
- The building's potential for expansion.
- Compatibility with sites being considered in the jurisdiction.

If everything about the building works for the jurisdiction, it would be fair to consider it a potential prototype. If not, the jurisdiction must determine whether it can adapt its operations, staffing, and needs to accommodate the prototype's noncompliance with local requirements, preferences, and practices. As with any other purchase, however, the jurisdiction is advised to check products and prices at more than one location.

The cost savings realized by buying someone else's plan may not be as great as hoped. The initial savings may not be worth the loss of the opportunity to creatively plan and program a facility to meet the specific needs of the local community that will operate it for the next 30 years or more. For example, assume the architectural and engineering fees for a normally developed project are 7 percent of the cost of construction. In buying someone's plans, the community would have to negotiate payment to the programmers, architects, and engineers who created the design and who retain copyrights to it. The community may also have to negotiate payment to the client who paid for the design and who may have legal rights to it. Costs will also be incurred for doing whatever site adaptation is required and for preparing a full set of drawings to which the architect can legally affix his or her license stamp and for which permits will be sought. Any changes to the prototype plan would also incur potentially significant costs.

The savings that actually accrue from reduced planning and design and an earlier construction start are likely to be 2–4 percent of project costs. If a jurisdiction considers that over a 30-year life cycle, the operating costs for a jail are 10 times greater than the construction costs, the savings realized through using a prototype dwindle to 0.2–0.4 percent of project costs. For example, a creatively planned and designed original facility that saves one full-time-equivalent staff position per year as compared with the prototype will, over 30 years, accrue many times the amount of savings on design and planning costs hoped for with use of a prototype.

Buyer Beware

Not all jails are alike. Cost savings through use of a prototype are generally not as significant or as certain as a community may think or hope. Use of a prototype should be approached carefully and thoughtfully, with a complete awareness of the issues involved. Decisionmakers should focus on the real cost implications of sacrificing opportunities for creative, efficient, and specific solutions to community needs if thorough predesign planning and original design are bypassed.

Planning Steps

Four main phases in predesign planning are directed toward answering basic planning questions and preparing a jurisdiction for design (exhibit 2-2). They can be initiated separately in sequence or collapsed into one overall predesign planning process as part of a larger facility development process.¹

- The first phase is project recognition.
- The second phase is needs assessment.
- The third phase is facility program development.

¹ These phases are based on the facility development process developed for the National Institute of Corrections by Gail Elias, Dennis Liebert, and James Robertson (2004).

Exhibit 2-2. Phases of Predesign Planning

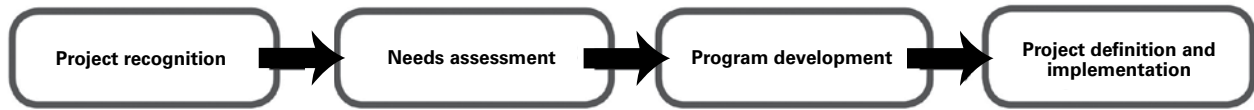

- The fourth phase is the project definition and implementation plan.

Each phase is described briefly here. More information is available from the National Institute of Corrections’ Jails Division and Information Center.

In general, the local planning team will need the assistance of an experienced consultant to assist with these steps. However, it is essential that local officials, staff, and citizens remain very involved with the process to ensure that the results are compatible with local needs and desires.

Phase 1: Project Recognition

This phase begins when local officials start looking at crowding issues and conditions in the existing jail. It involves several tasks related to taking a hard look at the criminal justice system as a whole and then starting or completing the following tasks:

- **Recognizing the problem.** Is jail crowding the precipitating event? Is the facility in need of expansion, repair, or replacement?
- **Developing the project’s organizational structure.** Who can and should be included in the process? What role will they play?
- **Identifying resources.** Where can data be found? Who can retrieve needed data? What information technology is available or needed?
- **Identifying the agency taking the lead.** Which agency will be responsible for facilitating the

process, ensuring that assignments are completed, and noting the decisions that are made?

This phase involves the start of the following activities:

- Gathering information for the selection of the facility site.
- Identifying the financial considerations for the project.
- Evaluating the need for a criminal justice planner for project guidance.

Phase 2: Needs Assessment

The needs assessment phase is frequently referred to by other names that are less descriptive, such as “master plan” and “feasibility study.” For brevity, it will be referred to as the “needs assessment” phase. In phase 2, participants are involved in the following tasks:

- Developing a policy group.
- Reviewing applicable standards and legal requirements.
- Developing the system mission statement and goals.
- Evaluating the current criminal justice system and policies.
- Evaluating the existing facility for standards compliance.
- Evaluating existing alternative programs.

Section 1: Getting Started

- Evaluating current staffing levels against the staffing levels that are needed.
- Identifying options, including:
 - Evaluating changes to policies and practices in the criminal justice system.
 - Evaluating the facility to determine whether renovation/expansion is needed.
 - Evaluating nonfacility alternative programs.
- Appointing a transition team leader who will be involved in all aspects of the project.
- Developing cost estimates for the project and staffing/operational costs for the first check-point for the project.
- Developing and producing a needs assessment report and a determination of inmate capacity by year.
- Starting to develop support for the project in the community.

The needs assessment phase is to the facility development process what the foundation is to a building. If the foundation is weak, the entire building is likely to exhibit flaws throughout its life.

Phase 3: Facility Program Development

The functional and space programs are brought together in phase 3 in a document that will tell the architects how the jail will function. In phase 3, participants will be involved in the following tasks:

- Developing a functional program, which includes:
 - Developing operational principles and functional scenarios.

- Reviewing applicable state and national standards.
- Developing a staffing plan for the new facility.
- Developing a space program, which includes:
 - Identifying square footage needs for the new facility.
 - Developing adjacency diagrams.
 - Analyzing design criteria.

Phase 4: Project Definition and Implementation Plan

In this phase, all of the information gathered and decisions made in the previous phases are further refined and gelled into a conceptual design and the refinement of site requirements. In phase 4, participants will be involved in the following tasks:

- Evaluating facility options (new construction versus renovation/expansion).
- Developing a conceptual design for the new facility.
- Developing a cost-benefit analysis and life-cycle costs.
- Conducting user and owner reviews.

When a jurisdiction is going through the planning process, there are many tasks that must be addressed to ensure successful design and occupancy of the new facility. The following tasks must be completed in the predesign process.

Developing a Mission Statement

The basis for making project decisions is to define the purposes of the jail in the jurisdiction and develop what is often called a mission statement. The mission statement will define many fundamental aspects of the jail and includes:

- The legal mandates for the jail.
- The entities responsible for its operation and funding.
- Who will be incarcerated in the jail and why.
- Responsibilities for safety, security, and service to inmates, staff, and the community.
- The correctional philosophy of the jail with respect to both pretrial and sentenced inmates, including programming, goals of punishment, reintegration into the community, rehabilitation, and so forth.

Although some of these issues may seem vague, they can have a direct impact on the size and type of jail that is built. For example, if the planning team determines that responding to alcohol abuse is part of the facility's mission, planners will be guided to provide spaces not only for receiving people who are under the influence, but also for offering counseling and other support services.

Learning More About Jails

Two truths apply to jail planning. First, things have probably changed greatly since the last time the jurisdiction built a jail. Second, although the jail staff works hard on a daily basis, they may be too mired in the existing jail's problems to be broadly aware of modern concepts, requirements, and possibilities. It is therefore very valuable to spend time early in the process, before preconceived notions take root, to learn more about modern jails. Learning about current issues and concepts can be done by:

- Participating in training programs on jail planning and inmate management, like those provided by the National Institute of Corrections.
- Attending conferences sponsored by professional organizations such as the American Jail Association and its affiliated state organizations.

- Touring new facilities in other jurisdictions.
- Reading articles and books.
- Working with experienced jail planning consultants who can make oral and visual presentations on jail issues.

Establishing Bed Capacity

No one has a crystal ball to see into the future. Yet projecting the number and type of jail beds that will be needed in the years after the new jail opens is an important early task in the needs assessment phase. The total number of beds drives facility development and operational costs more than any other factor.

Establishing bed capacity is not simply a function of executing mathematical projections of future need based on past data trends. For one thing, past data may be of limited use because crowded conditions may have forced local criminal justice officials to release people in ways that are normally undesirable. The data then would be artificially low and unrepresentative of true historic needs. Mathematical projections based on that data would be too low, raising the unhappy prospect of crowded new facilities shortly after opening. Multiple issues should be considered when establishing future bed needs:

- Projections of data other than jail average daily population (e.g., bookings, criminal case load, arrests, average length of stay).
- The condition of the local economy and community.
- Local and regional population growth and demographic changes.
- Use of alternatives to incarceration, such as releasing pretrial inmates on their own recognizance or creating a home arrest program (electronically monitored or otherwise) for sentenced inmates.

Exhibit 2-3. Daily Counts and Average Annual Population

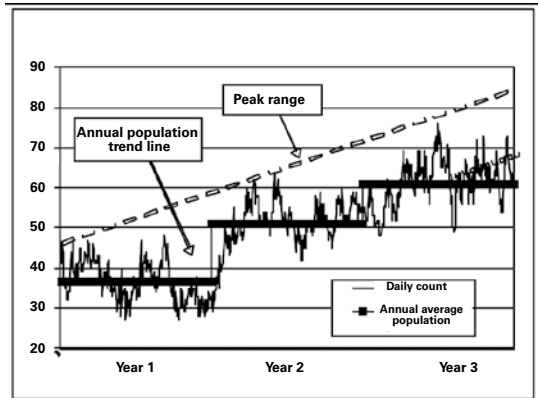

- Streamlined criminal justice case processing that results in shorter pretrial lengths of stay and thus a lower jail population.
- Changes in law that could measurably increase or decrease the jail population, such as a state mandate that nonviolent felons serve jail time rather than a state prison sentence.
- Inmate classification and separation requirements (see chapter 5, “Classification/Separation”).
- Daily, monthly, and annual deviations from the projected trend line to examine population peaks (exhibit 2-3).

The bed capacity must be arrived at by a consensus of local officials using jail data, analysis of past and current forces impacting the jail population, and good judgment. A mathematical projection is only one tool to help in establishing the bed capacity.²

The results of a bed-capacity-setting process will include capacity projections broken down by:

- Year (for 10–20 years into the future for initial construction, and beyond for use in planning for expansion).
- Types of beds needed (male/female, security or classification type, special needs, program or reentry), which will determine the number and size of the jail’s living units.

In addition, the capacity-setting process may recommend alternative policies and practices for the criminal justice system to limit the growth in the number of inmates or describe otherwise unexpected increases due to changes in policy or law.

Conditions that can lead to inadequate capacities in the future include the following:

- Lack of adequate data about the past.
- Trends that are difficult to interpret.
- Poor implementation of alternatives to incarceration that are central to the adequacy of the selected capacity.
- Unanticipated changes in law, philosophy, and culture.

Major Building Considerations

Once the capacity is set, reasonable conclusions about the general magnitude and character of the building can be reached by making basic decisions with respect to several major considerations. These allow preliminary calculations of required building square footage and thus allow the development of feasible options and accurate cost estimates. They also drive operational costs. Following are the major considerations to address:

- Confirming the inmate classification/separation system established during capacity setting.

² For additional guidance on establishing bed capacity, see David M. Bennett and Donna Lattin, *Jail Capacity Planning Guide: A Systems Approach* (Washington, DC: U.S. Department of Justice, National Institute of Corrections, 2009).

- Determining the appropriate occupancy level for each classification of inmate (i.e., single-occupancy cell, double-occupancy cell, multiple-occupancy cell, dormitory).
- Establishing the method(s) by which inmate surveillance/supervision will occur in housing areas.
- Estimating staffing needs relative to different design and management concepts.
- Identifying the range of nonhousing functions in the jail that must be supported by space (e.g., booking, medical services, programs, administration).
- Ascertaining which services (e.g., food, laundry) can be obtained elsewhere or to what outside agencies the jail might provide services through expanded facilities.
- Deciding the degree of expansion to be accommodated.

Option Development

Once the planning team has a picture of jail space needs, it can begin to explore options for accommodating those needs. The team will see the shortfall between needed beds and support space and the existing jail capabilities. Can the needs be accommodated through a renovation of or addition to the existing jail? Can the existing jail accommodate the key supervision and occupancy concepts established? Is new construction the only practical way to provide capacity and solve other problems with the existing facility? Should facilities separate from the jail be provided for inmates assigned to work release or other types of programs? Can a multijurisdictional facility be created for all inmates or selected groups, such as females? What are the differences between downtown construction and building on the edge of town or at a remote site?

The needs assessment phase will help answer these questions and also develop an idea of the construction, project, and operational costs of each option as well as sources for the needed funds.

When Planning Works Well

Rather than viewing planning as a number of hurdles that stand in the way of getting a new building, jurisdictions should see it as an opportunity to ensure that they get the building they need—one that will serve the community for many years to come. Planning works best when:

- It is done with considerable involvement of local government, which must fund the jail; the sheriff's office or jail management authority staff who will work in the jail; other affected agencies in the criminal justice system; and citizens, whose taxes support the jail.
- It results in these groups buying into the project and supporting it at each major phase, from funding to operations.
- The jurisdiction gets a jail that fits its needs and budget.

To achieve these benefits, jurisdictions are advised to consider: planning to plan, who will do the work, and how long it will take.

Planning to Plan

It is important that:

- Sufficient time is allocated to planning.
- The process is understood by all of the participants.
- Group authority and the decisionmaking process are outlined.
- The tasks and steps are clearly organized.

**Section 1:
Getting Started**

- A timetable is followed.
- Resources are allocated to planning.

The planning team will need to define the steps that the jurisdiction will take, develop a schedule for each phase, and obtain the staff time, money, and perhaps consultant expertise required to do the work.

Who Does the Work?

Can local staff do the predesign planning work? They may be able to if the jurisdiction has people available with the expertise and the time, but most do not. Because whoever develops the basis for the planning effort must be able to analyze the justice system and work with jail staff to describe the operations of the jail, most architects would not qualify either. In most cases, the jurisdiction will need to consider the use of consultants who are specialists in jail planning. They may be hired as part of the architectural or

design-build team or separately, before the design team is selected. The latter arrangement has the advantage of establishing the scope of the project prior to negotiating fees, which are usually based on the size, cost, and complexity of the building.

How Long Does It Take?

The project recognition phase (phase 1) can take a great deal of time or very little time, depending on the jurisdiction. However, as a rule of thumb, if adequate data are available, jurisdictions should allow 4 to 6 months for the needs assessment, 4 to 6 months for facility program development, and 4 to 6 months for project definition and implementation. Additional time is often needed for data collection if the data cannot easily be retrieved, report writing, public and agency involvement, and county review and approval. Exhibit 2-4 shows an example of a predesign planning schedule.

Exhibit 2-4. Typical Allocation of Time for Predesign Planning

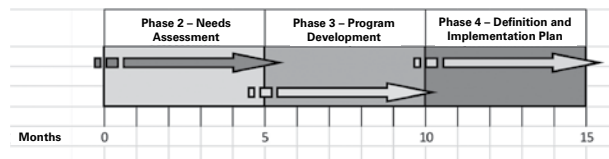

Chapter 3. Site Selection and Design	19
Chapter 4. Image/Appearance	29
Chapter 5. Classification/Separation.	33
Chapter 6. Surveillance/Supervision.	45
Chapter 7. Staffing Impact	57
Chapter 8. Security Perimeter.	69
Chapter 9. Criminal Justice Interface	83
Chapter 10. Functional Components and Relationships	93
Chapter 11. Planning and Designing to Standards	103
Chapter 12. Expansion.	109

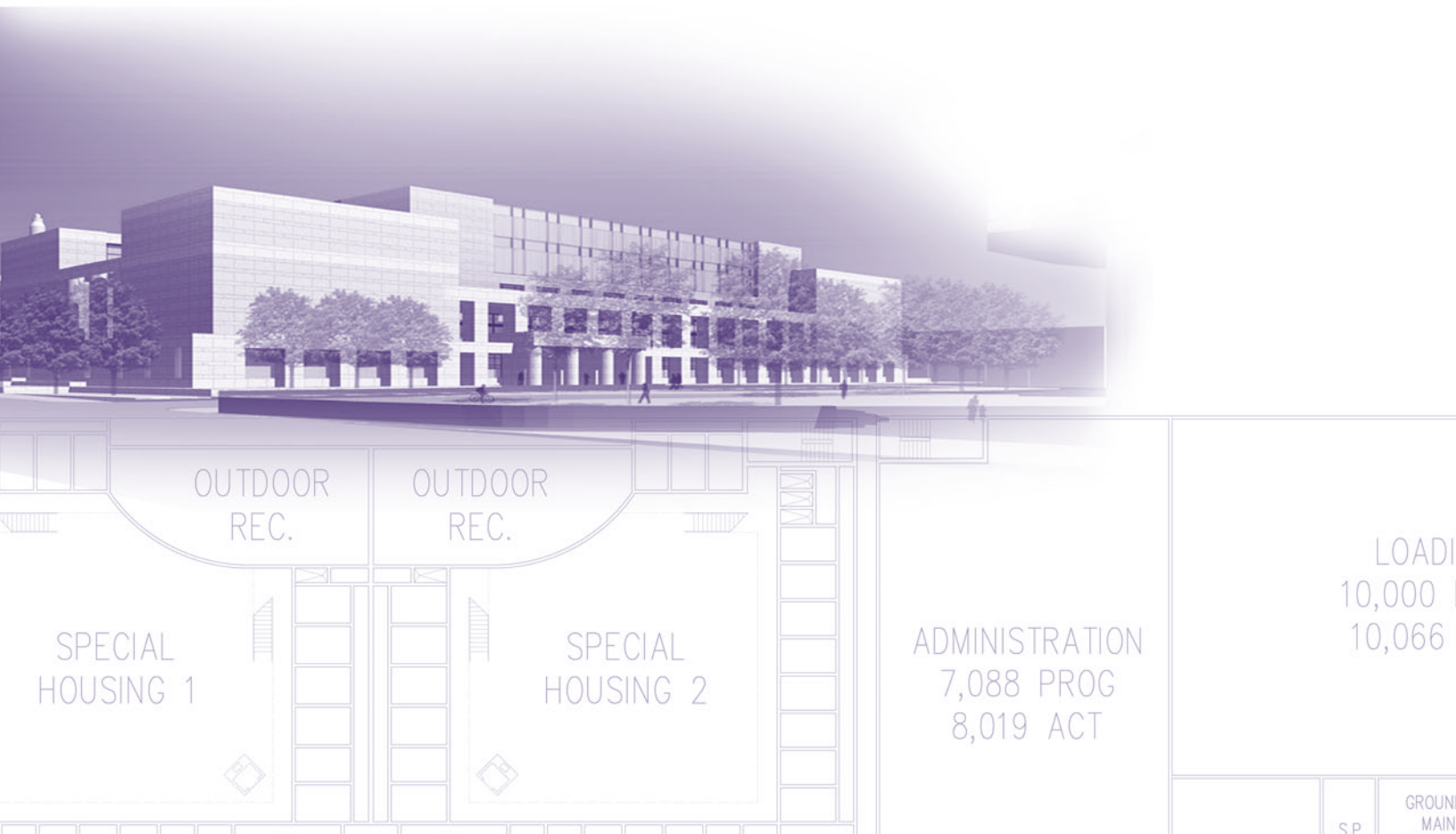

Major Design Considerations

When predesign planning is complete, it is time for the architect and the client to undertake the design process. This process starts with preliminary schematic designs of a very basic nature. These initial designs explore a series of major considerations that will fundamentally influence the direction of the design well before individual spaces are drawn. They also allow for a preliminary estimate of staffing needs.

Each of these major considerations involves fundamental operational and security decisions that should have been made during the predesign planning process. They are, in essence, the “big ideas” that make the design work in the way intended by local officials, operators, and users.

This section identifies and elaborates on the major considerations relevant to jail design. Specific information about various jail components and spaces—the detail that completes a design—is given in section 3. The considerations addressed in this section are as follows:

- Site selection and design.
- Jail image and appearance.
- Classification and separation.
- Surveillance and supervision.
- Staffing impact.
- Security perimeter (the “envelope”).
- Criminal justice interface.
- Functional components and relationships.
- Planning and designing to standards.
- Expansion possibilities.

Although it is not the purpose of the *Jail Design Guide, Third Edition* to instruct on the predesign planning process, considerable planning and operational content is included in each discussion.

Chapter 3

Site Selection and Design

The location of the jail will affect its operations, access to other components of the criminal justice system, and the convenience of staff and visitors for years to come. It will also affect construction, project, and annual operating costs.

Site selection is frequently a difficult political issue. Finding a location acceptable to the public has been a major stumbling block to many projects, resulting in delays and, in some cases, the termination of an otherwise well-planned effort.

Careful site selection is one of the most important features of a successful facility development process, as is the consideration of a site's impact on design. This chapter presents information about site selection and design needs that must be taken into account in choosing and developing a site for a new jail. The various issues surrounding site selection can be organized around three primary factors: size, location, and cost.

Site Size

The size of the site will greatly influence design. Size needs are a function of the size of the ground-level area of the building (including areas for nonjail functions) and other areas needed for expansion, parking, building access and roads, outdoor activities, landscaping buffers, and support elements such as outdoor equipment. In rural sites, nonbuilding elements may comprise 80 percent of the site area.

Building Area

When first considering site possibilities, it is important for jurisdictions to appreciate how much larger a new jail will be as compared with the existing jail. It is not unusual, for example, for

new facilities to be four to six times larger than older facilities, even though they have only twice the capacity. This is typically due to the increase in bed capacity and several other key factors:

- Increased requirements for square footage per bed in housing areas.
- Increased provision of program and support space.
- Inclusion of oversized support and program areas to accommodate future expansion of bed capacity.
- Compliance with jail standards.

Jurisdictions may expect the new jail to be only twice as large because the projected capacity need is only twice as great. This misperception has led to difficulties in developing a useful list of site possibilities and to early public commitments to sites that were too small.

The actual ground area required for the building is critical to determining site size. However, for the following reasons, ground area is rarely the same as the total square footage documented in the space program developed during predesign planning.

- **Irregular shapes.** To achieve interior efficiency, many jails have irregular (e.g., nonsquare or nonrectangular) shapes that create unusable spaces between portions of the building (exhibit 3-1).
- **Multiple levels.** Whereas small and medium-sized jails tend to be most effectively developed as one-level structures, larger facilities may require multiple levels because of their large size. Additionally, the facility, whatever the size, might be developed on multiple levels

Section 2: Major Design Considerations

Exhibit 3-1. Typical Irregular Shape of Jail

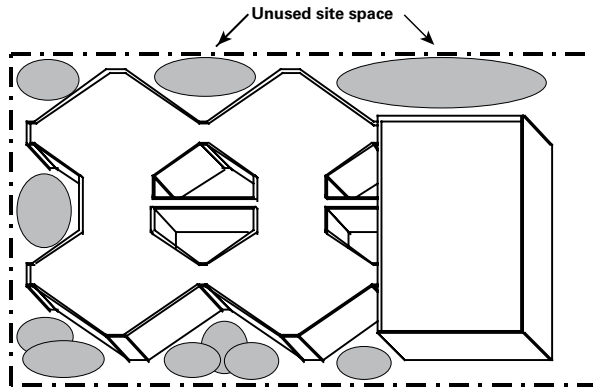

if it is to house other criminal justice functions (e.g., law enforcement, courts). Such multi-level structures might include a basement level for mechanical systems, computer rooms, and storage. Jurisdictions are cautioned against deciding to build a multilevel jail merely to save on the amount of site area needed. Before committing to a multilevel jail, jurisdictions should confirm that such a structure will not compromise the functioning and security of the building and will not increase staffing needs beyond acceptable and supportable levels. If a multilevel jail must be developed, the functions that must be on the ground level should be identified and potential sites studied to see if they can accommodate those functions.

- **Two-tier housing.** Some designs use two-tier housing—one cell over another and sharing a common single-level dayroom—thus saving ground area coverage.

Building Expansion

Many new jails are designed without consideration of the need to expand capacity in the future. With the many changes that have occurred and can occur in criminal justice philosophy,

state law, and arrest rates, expansion planning must be part of any facility development process. In establishing the size of the required site, jurisdictions must consider the potential need for future expansion in the following areas:

- Bed capacity.
- Jail support services and program area.
- Nonjail functions that share the building or site, for example:
 - Law enforcement.
 - Courts and court services.
 - Clerk of courts.
 - Prosecuting attorney.
 - Probation/parole.
 - Pretrial services.
 - Day reporting or other alternatives to incarceration.
 - Other county offices.

In the absence of specific expansion plans, providing twice the area of the jail for expansion needs would not be unreasonable.

Parking

The parking needs of a jail facility can be considerable and, at approximately 350–400 square feet per car, can represent a significant onsite requirement. Jurisdictions should consider the number of facility staff, family and professional visitors for inmates, and other visitors when determining the amount of space allocated for parking.

Staff

Planners should estimate one car per employee on the largest two shifts combined to allow adequate parking at shift change. For example, if 9 employees work on shift 1 and 7 employees work

on shift 2, then 16 parking spots will be needed at shift change. It is also important to consider parking for administrative and support staff.

Inmate family and personal visitors

Two cars for the maximum number of visitors allowed at one time allows enough parking for both the persons visiting and the persons arriving for the next visiting period. This provision assumes scheduling of visits so that visitors arrive sequentially rather than all at once. Without scheduling, parking demands will be greater. For example, if the maximum number of visitors during a visiting period is 20, then parking for 40 cars is necessary during the visiting period: 20 for current visitors and 20 for visitors waiting for the next visiting period.

Others

Parking spaces should also be allocated, as appropriate, for:

- Arresting officers from city, county, and state agencies.
- Outside service providers (doctors, nurses, counselors, volunteers, maintenance workers).
- Work release inmates.
- Official vehicles, such as transport vans and patrol cars.
- Business/official visitors (lawyers, bondspersons, sales representatives, vendors, probation officers, judges, prosecutors, law enforcement officials).

Number of parking areas

A key consideration in determining parking needs is whether all parking can be in one large area or whether it must be in multiple areas with separate access. The chief advantage of a single large parking area is that during peak needs, such as those occurring at staff shift changes and during

visiting, additional vehicles can be better absorbed into fewer overall parking stalls through scheduling. A primary advantage of multiple parking areas is that secured parking can be provided for staff cars and official vehicles that are sometimes subject to vandalism (exhibit 3-2). Additionally, separate areas tend to better recognize an official, professional status, particularly if select parking stalls are reserved or protected from the elements (such as shedlike covered areas or a parking structure). At a minimum, consideration should be given to establishing a certain number of reserved parking stalls if a single large area is developed.

Convenience and functionality are additional reasons to consider separate parking areas, accesses, and drives and their impact on site size. For example, it may be desirable to create separate parking for arresting officers near the booking area and near where they can reenter the facility to complete any remaining business pertaining to an arrest (e.g., filing reports or evidence,

Exhibit 3-2. Multiple Parking Areas

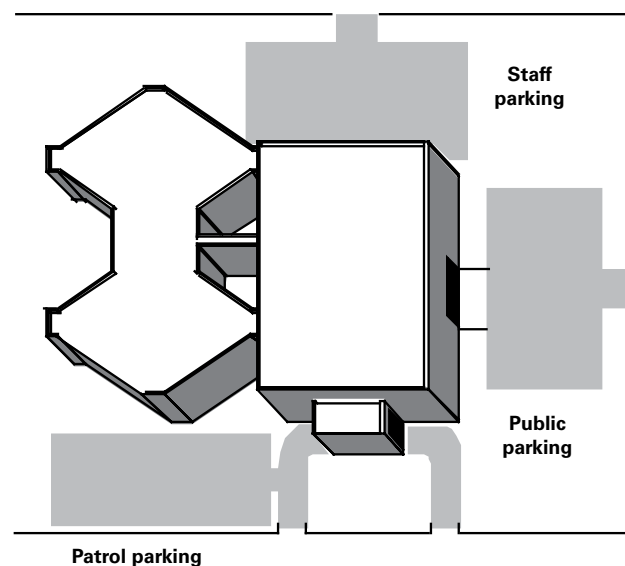

Section 2: Major Design Considerations

disposing of inmate property). Expansion needs must also be considered when calculating a facility's parking and site needs.

Outdoor Spaces

The principal outdoor areas needed for a jail are as follows:

- **Inmate exercise area(s)**, which can be walled, fenced, or unenclosed, depending on the security level of inmates.
- **Emergency egress/refuge area**, a controlled outdoor area where inmates can be temporarily evacuated in an emergency. This may be the same as the exercise area, if it is far enough from the main building to safely contain inmates (check local building and fire codes for more details).
- **Outdoor visiting area** for minimum-security inmates, perhaps with table seating.
- **Farm or garden area**, if the facility grows some of its own food or has an inmate work program.
- **General landscaping area** for aesthetic purposes and the creation of buffers between the building and the public.

Access to the Site and the Facility

Land area will be needed for the vehicle drive-ways and pedestrian walks required for building access and services. The principal forms of access for which area must be provided include the following (exhibit 3-3):

- Arrestee delivery and transport, frequently in association with a secure vehicle sallyport and a secure pedestrian entry.
- Food service delivery, which may involve semi-trailer trucks.
- Supply delivery, which may also require space for semi-trailer trucks.

Exhibit 3-3. Common Facility Access Points

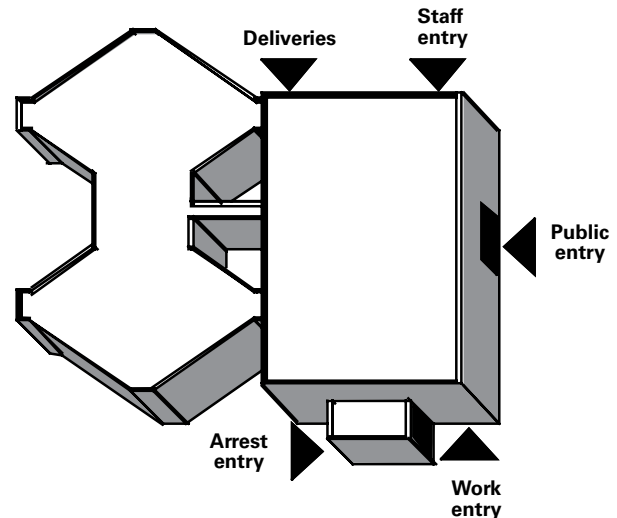

- Staff (affiliated with parking).
- Public/official visitors (affiliated with parking).
- Inmates, staff, or visitors with disabilities (affiliated with parking).
- Work release/periodic inmates, when, for security reasons, they enter and exit at a point different from that for arrestees and releases.
- Garbage removal.
- Emergencies, including medical and fire, which may require space for staging large vehicles.
- Mechanical repair/equipment replacement.
- Personnel from other agencies, such as law enforcement.

Support Elements

Ground space may be needed for:

- Radio antennas.
- Gas tanks and pumps.

- Utilities (e.g., transformers, sewage treatment).
- Water retention areas (in locations where on-site management of water runoff from heavy rainstorms is a concern).
- Garbage dumpster/compactor.
- Maintenance shop.
- Storage buildings.
- Special law enforcement needs (e.g., impound yard or building, vehicle service bay).

As “green” building increases in popularity, space may also be needed for geothermal sites and other green services.

Total Site Area

The total area required for the site is the sum of the elements discussed above:

- Site size = building area (multiplied by an irregular shape factor)
- + building expansion area
 - + parking areas and parking expansion
 - + outdoor spaces
 - + walk and drive access areas
 - + support element areas

When the size of the site has been determined, identification of a location can begin in earnest.

Site Location

The location of the jail must satisfy the following major concerns: linkages, surroundings, views and inmate contact, existing jail sites, and technical requirements.

Linkages

In locating the jail, several important relationships, or “linkages,” should be satisfied. The jail should be designed with awareness of relationship or proximity needs to:

- **Courts.** Maintaining efficient and secure movement of inmates between the jail and the courts may be the single most critical linkage. A direct physical connection through secure walkways or tunnels is most desirable, although being on the same site is of some value. On the other hand, if inmates must be transported between the jail and the courts, a distance of a few blocks or a few miles makes little difference because most of the transfer time is taken up with readying the inmate and loading, unloading, and readmitting the inmate rather than with driving.
- **Sheriff’s law enforcement functions.** These include investigations, interrogation, sharing of staff and facilities, and backup. It is considered most desirable to have a direct physical connection between the jail and other law enforcement functions, although being on the same site but unconnected is also valuable. **This is especially true for smaller facilities that rely on law enforcement personnel for backup in the jail.** (See chapter 9, “Criminal Justice Interface.”)
- **Services.** It can be desirable for the jail to be convenient to lawyers, a health care center, educational resources, volunteers, employees’ homes, and community groups such as Alcoholics Anonymous. Additionally, proximity to emergency resources such as the fire department and medical emergency facilities is important.
- **Transportation.** The jail should be easily accessible to all staff working in the facility as well as to visitors and others. Proximity to public transportation systems in the area is desirable.

Surroundings

It is important that the jail be located in appropriate surroundings. If the jail is located in the right type of area, conflicts with different types of functions will be avoided. The best locations

Section 2: Major Design Considerations

are in government, light industrial, or commercial areas.

Views and Inmate Contact

Controlling views and contact between inmates and people of the surrounding area is an important consideration in site selection and design. There are several typical problems: outdoor exercise areas, view conflicts from inmate-occupied areas, physical contact at the security perimeter, inmate workers, and arrestee entry.

Outdoor exercise areas

The tendency to create an inexpensive, ground-level exercise area that can double as an outdoor emergency refuge area can, especially in downtown areas, create sight, sound, and physical contact problems, especially escape and contraband passage through, under, or over fences.

To help resolve this, the use of solid walls, protective screens over the exercise area, and careful placement of exercise yards within the floor plan can be effective. (See chapter 19, “Exercise Areas.”)

View conflicts from inmate-occupied areas

View conflicts can result, especially in downtown areas, from the use of windows to provide required or desired natural light in inmate-occupied areas. This is most acutely the case with cell windows at ground level, although view conflicts from program areas (e.g., multipurpose rooms) can also occur. Some solutions to the problem include:

- Creating a heavily landscaped visual buffer (recognizing that trees and shrubs take time to grow).
- Creating window sill heights well above floor levels (exhibit 3-4).
- Using tinted or reflective glass in windows in conjunction with night lighting on the exterior

Exhibit 3-4. Window Sill Height Above Floor Level Prevents View Conflict

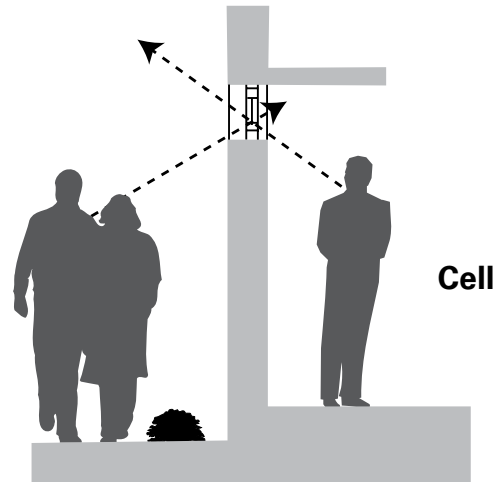

of the building, to limit exterior-to-interior visibility while preserving inmate views and discouraging outside approaches to the building.

- Using translucent glazing in windows to provide natural light only (if allowed by local standards and codes).
- Using inaccessible skylights or clerestory windows to provide natural light and, possibly, a view of the sky. Clerestory lighting, in particular, has to be studied because views may unintentionally be created between the inmate areas and the upper portions of an adjacent midrise building.
- Placing windows where they look out onto controlled exterior spaces, such as courtyards or walled-in areas (exhibit 3-5).

Another concern is view conflicts between different inmate-occupied areas where total visual separation is required (see chapter 5, “Classification/Separation”). Care must be taken, for example, not to create view conflicts between male and female cell areas through exterior or interior windows.

Exhibit 3-5. Placement of Window To Look Out Onto Controlled Space

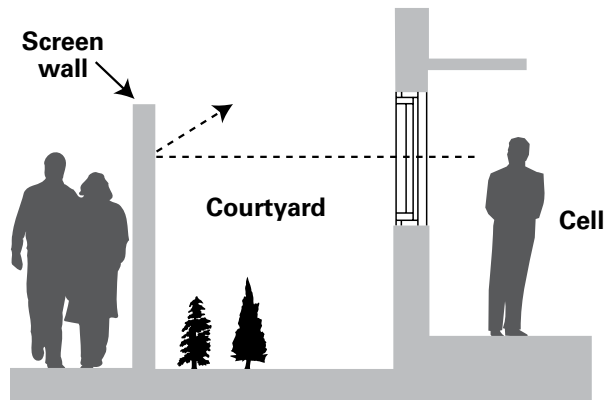

Physical contact at the security perimeter (the “envelope”)

Physical contact with windows in inmate-occupied areas, especially housing areas at ground level, is a major concern in terms of escape and contraband passage. Responses include:

- Building secondary perimeters (fences, walls).
- Keeping sill heights as far above grade as possible.
- Planting tough, thorny bushes around the perimeter to discourage spontaneous, random contact (although such plantings can provide a hiding place as well).
- Using security glass in a secure window design (framing, anchoring, glazing, opening size), possibly also including alarm systems built into the window.
- Eliminating exterior windows (where allowed and acceptable) and introducing natural light indirectly through better protected sources within the perimeter.
- Using perimeter security systems (e.g., closed circuit television (CCTV), lighting, infrared

systems, pressure sensitive systems), although careful consideration must be given to costs for the systems, staffing requirements to monitor such systems, and the aesthetic impact on site surroundings.

Inmate workers

Jail operations usually include an inmate work program in which inmates provide services inside the facility (e.g., kitchen and laundry workers) and sometimes outside the facility (e.g., car washing, lawn mowing). Such a program, and the visibility and contact it implies, should be considered in terms of its impact on surrounding land uses.

Arrestee entry

Officers bring arrestees to the jail daily, sometimes with the arrestee in an agitated state. Although providing a fully enclosed vehicle sallyport for this purpose has become common, some facility programs may not include a sallyport. The absence of an enclosed sallyport presents view, sound, security, and even physical contact issues that may be totally inappropriate for certain sites, given the surrounding buildings and their functions.

Existing Jail Sites

Existing jail sites are frequently considered natural sites for new facilities because they are generally in good locations and are already accepted by the public for jail use. However, there are four typical concerns with existing jail sites: early demolition, integration of the existing jail, the effect on other criminal justice facilities, and historic preservation.

Early demolition

If the existing jail must be demolished to make way for construction of the new facility, major inconvenience and cost can be incurred for:

Section 2: Major Design Considerations

- Transporting and boarding inmates elsewhere during the entire construction period.
- Making arrangements for short-term holding of arrestees or for holding arrestees who are required to make regular court appearances.
- Ensuring timely court appearances.
- Displacing associated law enforcement and criminal justice functions if they were also in the jail building.

Integration of the existing jail

There is a temptation to reuse the existing jail for part of the new jail's functions. Doing so would be disadvantageous were it to result in a relatively small amount of generally deficient jail space overly influencing and compromising the design of a significant amount of new facility space.

Effect on other criminal justice facilities

When the jail is on the courthouse site, planners must be careful not to limit growth options for adjacent court and criminal justice functions by focusing the planning on the jail alone. In such cases, jurisdictions are advised to consider doing a master plan for the entire local justice system before making site commitments, to ensure that all needs are adequately accommodated. Planning for new facilities on existing courthouse/criminal justice sites must also consider overall county government parking needs, which are frequently overlooked.

Historic preservation

Existing jails, or the buildings that house existing jails, particularly if they are associated with the courts, frequently have historical value, if not to county officials, to citizens' organizations and to state or federal officials. Jurisdictions considering demolition or renovation should ascertain the historical status and value of existing jails. It

is also wise to check the historical status of any building that may be affected by the proposed project either now or in the future when expansion might occur.

Technical Requirements

The design team should identify and deal with technical site design factors. Some of the technical factors are:

- The types of **soils** on the site, which affect the height and cost of the building.
- **Utilities** available at the site or the cost of carrying them to the site.
- **Topography**, or slope, which affects site drainage and the potential for flooding.
- **Zoning**, which could limit the height or square footage of the building or prevent its construction altogether.
- Impact on **traffic flow** around the site.
- **Environmental impact** studies.



Facade of a historic jail facility.
(Photograph courtesy of Jim Rowenhorst.)

Site Costs

The cost factors associated with any given site can be a significant element in determining its desirability. Key cost factors include:

- **Acquisition costs**, which may include legal costs if condemnation proceedings are required to obtain certain parcels or the entire proposed site.
- **Demolition costs** for existing buildings and removing materials from the site.
- **Utility costs** for bringing new utilities to a site or relocating existing utilities that would otherwise interfere with proper building development: gas, waste, storm sewer, telephone, electrical, and water lines. Utility costs can be quite high if the site under consideration must provide its own utilities, such as sewage treatment and water supply/treatment.
- **Site preparation costs**, which can include significant grading of uneven sites, providing fill in low sites or sites with unstable soil conditions, and excavating rock to create basements or foundations.
- **Construction impact costs**, which are additional costs that a site with special conditions or restrictions imposes on design or construction. Examples of conditions that impact construction costs are:
 - Less flexibility in design, leading to a less efficient facility that requires more staff.
 - Need for more elaborate and expensive exterior detailing, as with the greater needs of a downtown building next to a historic courthouse versus a rural site with no surrounding structures.
 - Need for a more expensive, tight, or complicated midrise or highrise structure due to a lack of site area.
 - Need for special basement foundation walls if the site is in a flood plain.
 - Difficulty in staging construction due to limited land on which to store building supplies and set up construction headquarters.
 - Site limitations that require underground parking or a parking structure.
- **Environmental impact study costs** associated with producing, or hiring consultants to produce, the required information regarding the selected site and/or effect of the project on the surrounding environment.
- **Environmental cleanup costs** associated with cleaning soil contaminated by gas and oil products or chemical spills.
- **Lost tax revenue costs** as the result of losing tax-producing land (e.g., businesses, farms, personal residences) or revenue-producing land (e.g., county parking lots, rental property).
- **Transportation costs** associated with providing staff and vehicle(s) for transporting inmates between the new jail site and the courthouse or other detention, corrections, or service-providing facilities. Additionally, a site remote from the courts might demand creating a secure vehicle sallyport and holding facilities at the courthouse for the secure management of inmates.
- **Boarding costs** generated by housing inmates at another facility. A typical example is when use of the existing jail site requires housing all inmates at other facilities during the construction period.
- **Annual energy costs**, which can differ according to site characteristics such as the presence of an aquifer that can be a source of chilled water to lessen air-conditioning and heating costs.

Section 2: Major Design Considerations

- **Phasing costs** of doing construction in multiple steps due to special conditions such as keeping an existing jail open during initial construction but tearing it down part way through the project in order to complete the project.

Site Selection Process

If only in terms of initially identifying and generally evaluating site possibilities, site selection must be handled early in the planning process. Preferably, it is done during predesign planning, as discussed in chapter 2. In selecting a site, jurisdictions should follow these steps:

- Define site needs, including size, type of location, and so forth.
- Set other site evaluation criteria.
- Identify potential sites.
- Gather information and evaluate each site.
- Allow for public input and discussion.
- Select one site.
- Acquire the site, if it is not already owned by the jurisdiction. If condemnation proceedings are needed to acquire parcels of a site, both time and funds may be required.
- Prepare a master plan of the site and an environmental impact report, if required. Jurisdictions are advised that an environmental impact report can take a considerable amount of time to prepare.

Risks of Premature Site Selection

Although early work on site selection is valuable, selecting the site too soon can be risky. Before selecting a site, a jurisdiction must develop enough information about the future operational space needs of the jail to answer the questions discussed in this chapter. Prematurely selecting a site that turns out to be too small or in the wrong location will result in a major setback in time, momentum, and, perhaps, money, as well as in embarrassment.

This happened in one jurisdiction in which the site was selected by the county (along with a federal agency) without any public knowledge or input and before facility requirements had been explored. When the location was revealed, it stirred up great controversy, although later it was determined that the site was too small anyway. Such situations can be avoided with proper planning done at the right time.

The site selection process can take quite a long time, especially if controversy or politics is involved. See the National Institute of Corrections' *Jail Site Evaluation and Selection*,¹ part of the New Jail Planning series, for more detail on the site selection process.

¹ Ken Ricci, *Jail Site Evaluation and Selection* (Washington, DC: U.S. Department of Justice, National Institute of Corrections, 2006), <http://nicic.gov/Library/021280>, accessed February 26, 2010.

Chapter 4

Image/Appearance

The jail projects an image and sends a message to the people who pass by, visit, work, or are confined there, although the way each person responds to the jail depends on why he or she is there. The building's image helps people recognize the type of place it is and establishes their expectations of what will happen there, how they will be treated, and how they should behave.

The typical jail of the past is easily recognizable: hard and impenetrable, with steel bars and barbed wire. Many people now think that this traditional jail image is inappropriate, given new attitudes about the role and purpose of the jail; that is, the desire to elicit normal behavior and to create a positive and accessible addition to the local community. Older jails tend to convey a message only of punishment and inaccessibility.



The Lexington-Fayette County Adult Detention Center in Lexington, Kentucky, was designed to fit into a rural area with numerous horse barns. (Photograph courtesy of Dennis Liebert.)

Exterior

The outside of the building conveys a message to the public about law enforcement and the role of the jail in the community. Jurisdictions should decide whether they wish to convey an image of community service, deterrence, frugality, or some other quality.

In considering the jail's appearance, jurisdictions should take into account the context in which it will be located. If it is to be located downtown, it may be important to repeat the materials, colors, and scale of surrounding buildings so that it fits in. If the jail is to be near or adjacent to other government buildings, it is probably desirable for the jail to complement those buildings to create a unified and identifiable government image. Even when facilities are located in rural areas, care should be taken to ensure that the building fits in its surroundings.

However, if the jail is to be located away from other buildings, the jurisdiction may be freer to choose the architectural elements desired. These might include less costly exterior building materials, such as decorative concrete block instead of brick.

Interior

The interior image and character of the jail environment will be most important to staff and inmates, but will also be important to visitors. Staff will spend more time in the jail over the years than will individual inmates. The image and character of the jail interior can affect staff's satisfaction with their jobs and can send a message about how they are perceived by their employers.

Section 2: Major Design Considerations

The interior of the jail can also express and reinforce an expectation about inmate behavior, since all people tend to respond to their environment. That is why good church design inspires quiet and reverence, why good field house design encourages openness and participation, and why good office design enhances productivity.

These concerns must be balanced against the perceptions of elected officials and the public. An interior that appears to be too nice to the casual observer can be interpreted as an intent to coddle inmates and create a hotel-quality environment. The mission statement of the jail (see chapter 2) will go a long way toward setting the aesthetic tone for the interior of the building.

Research has shown that where jails have eliminated the symbols of incarceration and provided a more normal setting, there have been positive effects on inmate behavior (e.g., a reduction in vandalism, assaults, and stress), as long as this approach is rooted in the actual operational philosophy used to manage the inmates. These jails tend to use elements such as carpet on the floor,

wooden cell doors, nonfixed furnishings, bright colors, and lots of daylight. Although using these features may seem counter to ideas about what makes a jail secure, inmates tend to treat the jail with more respect if its design communicates to them that they are also going to be treated with respect.

Differentiating the physical character of housing units can also be used to reinforce good behavior. For example, disciplinary housing units could have a more traditional jail appearance, such as concrete floors and fixed furniture, than the normalized general housing units. Thus, a more normal environment can be a reward for good behavior.

Maintenance of Physical Security

A more normal appearance does not require that security perimeters and fundamental construction be nonsecure. Floors underneath carpet can be concrete, and bright and pleasing paint can cover reinforced and grouted concrete masonry units. Wooden cell doors can be used in direct supervision general population units where penetration of the door will only allow the inmate access to a supervised dayroom in which an officer is always present, and daylight can be provided by security-glazed openings looking into secure-controlled exterior courtyards.

Operations: Key to Normalization

The latitude that can be taken in creating a more normative environment depends to a significant degree on concepts of surveillance, staffing, and classification, as well as on a clearly defined security envelope and internal zoning system. An inadequately staffed facility that does not maintain constant surveillance over inmates, poorly classifies and separates inmates, and poorly defines and controls its security perimeter will have



Dayroom with carpet, wooden doors, and more normative furnishings.
(Photograph courtesy of Voorhis Robertson Justice Services.)

less success with concepts of architectural normalization. Concepts of appearance and character must be derived from, and intertwined with, concepts of operations and security.

Describing Desired Appearance

After the jurisdiction considers the image and behavior it desires in the jail, the planning team must communicate its decisions to the design team. Adjectives should be used to describe the desired appearance of the new jail, or reference should be made to other buildings with the desired characteristics. Here are some contrasting adjectives to choose from:

- Open/closed.
- Spacious/confined.
- Free/controlled.

- Warm/cold.
- Welcoming/rejecting.
- Minimal/adequate/generous.
- Light, bright/dark, dim.
- Colorful/plain.
- Soft/hard.
- Friendly/unfriendly.
- Safe/dangerous.
- Caring/indifference.

It is essential that the planning team from the jurisdiction be clear about their desires and expectations so there is no misunderstanding when the facility design process begins.

Chapter 5

Classification/Separation

Physically separating classifications of inmates from each other remains a major design and operational problem for all jails. It is perhaps the problem that most distinguishes smaller jails from larger jails. This is because smaller jails must respond to the same variety of inmates as a medium or large jail, but generally have far less capacity with which to disperse and manage those inmates.

Housing units constitute about half of a jail's square footage and are the primary security areas of the jail. Consequently, classification and housing area separation have a fundamental influence on basic design arrangements and facility success. Attaining proper separation in the nonhousing areas is also essential to successful design and ultimate compliance with jail standards.

Classification and the issues of surveillance/supervision mode and staffing are closely linked. Consequently, readers are strongly advised to refer to chapter 6, "Surveillance/Supervision," and chapter 7, "Staffing Impact," when considering classification and separation issues.

Separation Problems

The difficulty of obtaining proper physical separation results from several basic problems: inmate types, cost of housing for different inmate types versus frequency of need, changes in inmate population, surveillance method, and cell occupancy.

Inmate Types

All jails, even very small jails, must develop an inmate housing plan based on the types of inmates housed in the current facility and, if data are available, a projection of the future inmate population. This is done by reviewing inmate

population types, or categories of inmates, and the number in each category. These data are then used to inform the design process to ensure that there is adequate housing for all categories of inmates.

When developing an inmate housing plan, the jurisdiction must consider which groups must be housed separately, and those that are traditionally housed separately, based on risk and need or legal reasons. However, depending on the supervision level in the facility, some of these categories might be housed together. These categories may include:

- Males/females/transsexuals.
- Adults/juveniles detained as adults.
- Inmates with special needs, such as those with contagious diseases or severe mental health problems (including suicidal ideation and developmental or physical disabilities).
- Prior arrest and/or conviction history.
- Prior incarceration experience.
- History of assaultive behavior.
- History of escape.
- Short- and long-term stays.
- Inmate workers/work release inmates.
- Arrest for a violent offense.
- Arrest for a drug- or alcohol-related offense.
- Immediate health problems.
- Intoxication.
- Sexual predators.
- Under medical treatment.
- History of alcohol or drug abuse.

Section 2: Major Design Considerations

- Violent and combative at intake.
- Known enemies in the facility.
- Gang members.

Unfortunately, many counties and designers dismiss the need for translating the separation needs of a classification system housing plan into the design of smaller jails. This may in part be due to an erroneous belief that smaller jails do not have to respond to the diversity of inmates encountered in larger jails. Experience has shown, however, that smaller jails must cope with many types of inmates—some of whom require physical separation and management—only in smaller numbers.



Inmates who present management problems and require special consideration in housing placement typically fall into several categories:

- Those who require protection and separation because they may be in danger from other inmates or are a danger to themselves.
- Those who, by reason of their offense, criminal record, or institutional behavior, require enhanced security and close supervision.
- Those who have received unusual publicity because of the nature of their charge or crime, the circumstances of their arrest, or the threat they pose to the public.
- Those who, by reason of their mental or physical condition, require special housing.

Program Space Considerations

In addition to using data on the characteristics of the current and projected jail population to make decisions about security levels, housing separations, and housing unit capacity, jail administrators and designers can use this information to make decisions about the type and size

of program space needed in the new facility. For example, if projections are that the jail population will include a high percentage of persons with drug- or alcohol-use problems, jurisdictions can use this information when planning for counseling and program space. If the population is characteristically youthful, planners may want to program space for physical activity and educational opportunities accordingly.

Cost of Housing for Different Inmate Types Versus Frequency of Need

Attempting to provide a cell or housing unit for each type of inmate is impractical because some types of inmates appear at the jail rarely or infrequently (e.g., civil commitment, severe mental illness). Yet when they do appear, the jail must have the capability to provide appropriate physical, sight, and/or sound separation.

Changes in Inmate Population

The makeup of the jail population can change considerably from year to year or month to month. Populations may go from two-thirds sentenced to one-third sentenced or from two-thirds felon to one-third felon in relatively short periods of time. The adult female population seems to be most vulnerable to major swings in peak as well as average daily counts and presents a significant design as well as management challenge. The impact of this variability tends not to be as extreme in a large jail, but is a special problem for smaller jails.

Surveillance/Supervision Method

Different forms of housing unit surveillance and supervision, and related staff posting concepts, create different challenges in maintaining proper inmate separation. Three approaches—remote surveillance, intermittent surveillance, and direct supervision—are summarized below. Surveillance methods and staffing are addressed in greater detail in chapters 6 and 7, respectively.

Remote surveillance

Remote surveillance designs, in which several housing units are clustered around a fixed control position, pose the greatest challenge, as visual and perhaps acoustic conflicts can occur between individual housing units as a byproduct of the clustering design (exhibit 5-1).

Intermittent surveillance

The success of podular/direct supervision over the past 20 years has caused most jurisdictions that are planning new facilities to eliminate or minimize the traditional linear jail design that relies on intermittent surveillance. In the intermittent surveillance model, the location and size of housing units are not closely tied to the location of a staff post; therefore, this model allows for many separate cellblocks and thereby facilitates the physical separation of inmates. However, intermittent surveillance has many operational drawbacks. Visual and acoustic separation capabilities are lost when housing units are located across from each other, back-to-back with each

other, or next to each other in one common cell-block area (exhibit 5-2). Many intermittent surveillance designs use steel bars on cell and dayroom fronts, thereby sacrificing sound separation and, in some cases, sight and physical separation.

Direct supervision

Separation tends not to be a problem with direct supervision because the units can operate in an essentially self-contained manner, thereby eliminating the need to affiliate them with control positions outside the unit or to expose them to full views from corridors.

Cell Occupancy

Older jails have much of their capacity in multiple-occupancy cells and dormitories that often compromise classification and physical separation decisions, especially when cells with four or more beds predominate. In such a jail, when an inmate requires separation from other inmates, he or she effectively occupies four beds rather than one. Furthermore, proper separation

Exhibit 5-1. Remote Surveillance Housing Unit

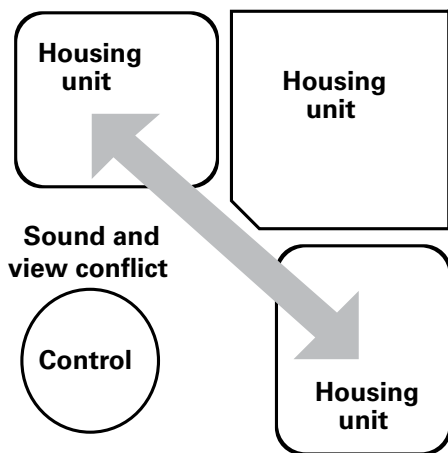
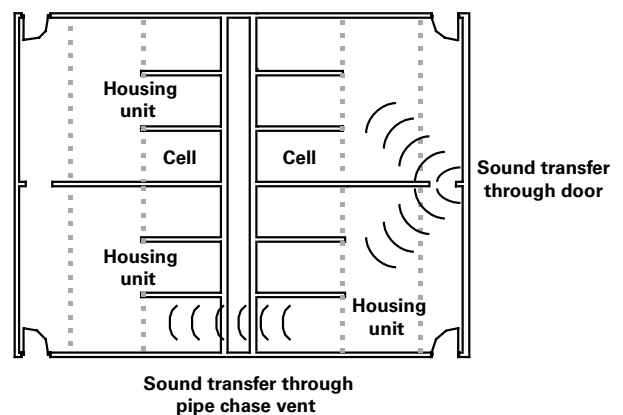

Exhibit 5-2. Intermittent Surveillance Housing Unit



Section 2: Major Design Considerations



Bar front cells in an intermittent surveillance facility.

still cannot be achieved because the “special housing” cell is part of an entire cellblock. The traditional bar grill cell-front design only worsens this problem, because not even physical separation can be fully achieved.

Classification Systems

A logical first step toward resolving separation problems in design is for the local community and jail administrators to identify the number and types of inmates with whom they must deal and to classify them into appropriate groups. Classification is a process of systematically assessing the risks and needs of jail inmates in order to respond to safety, security, health, and programmatic concerns. In some cases, the classification plan calls for separate housing of certain classification categories or requires that inmates in certain categories be housed in space equipped to handle their particular needs. Because of space limitations and the many classifications that can be established, a classification plan should also specify which types of inmates can be housed together.

Jail classification systems have improved, but some tend to be very subjective, in that they require independent judgments by jail personnel making the classification decision. In general, the subjective approach is based on determining an inmate’s relative conformance with several basic criteria (rules, regulations, policies, and procedures) that are extensions of the agency’s correctional mission and physical plant capability.

Objective jail classification systems are preferable because they minimize subjectivity by using classification criteria to which weights or values have been assigned. An objective classification process promotes fundamental fairness and consistency, two attributes that the courts increasingly look for when evaluating the adequacy of classification systems.

When and Where Classification Occurs

Initial classification typically takes place during the intake process in the booking area. If the jail does not have either holding cells in the receiving area or an intake housing unit, new inmates are assured of swift transfer into the general inmate population unless some means of release can be arranged almost immediately. Many jails rely heavily on multiple-occupancy cells that hold two or more inmates. These cells are not appropriate for inmates who have not yet been classified, as they can provide the opportunity for several foreseeable problems, including assaults, intimidation, fights, spread of disease, and passage of contraband.

If holding cells are available, classification decisions must be made during the inmate’s initial stay in temporary holding. If the facility has an intake housing unit for initial stays of up to 72–96 hours, observation of inmate behavior and classification can take place in a more deliberate fashion.

After classification, inmates are given a housing assignment consistent with their risk and needs assessment. However, an appropriate housing assignment is only possible if the facility design, and the separation it provides, is compatible with the established system.

Juveniles

With regard to housing juveniles in an adult jail, most standards call for housing only those who are subject to trial as adults and, even then, only if they are kept separate from adults. All other juveniles should be housed in separate facilities. Despite professional positions on this subject, the housing of juveniles remains a serious problem for geographically remote counties with small or medium-sized jails.

Given the sometimes protracted nature of the judicial process, housing juveniles to be tried as adults can involve stays of many months. This presents a real design and operational dilemma, in that the jurisdiction should probably provide enhanced supervision for juveniles. From a design perspective, however, it is difficult to achieve physical, sight, and sound separation for one or a few juvenile inmates without isolating them, thus reducing the potential for proper supervision and increasing the likelihood of problems such as vandalism, assault, depression, or suicide.

As difficult as the juvenile housing problem is for smaller jails, especially those in geographically remote areas, it is always more suitable to pursue alternative placement for juvenile inmates. Their presence in an adult jail presents nearly insurmountable operational and design problems. Jurisdictions should strive to place juveniles in facilities designed and operated exclusively for juveniles.

Resolving the Numbers Problem in Smaller Jails: Multijurisdictional Options

The basic classification problem for smaller sized jails is one of numbers. There are simply not enough inmates in most special categories to make complete separation consistent with an ideal classification system. Neither clever design nor advances in technology can ever fully bridge the gap, especially if affordable staffing patterns and facilities are required. Economics requires most small and medium-sized jails to house all inmate classifications in a single facility rather than provide one facility for adult males, one for adult females, and one for juveniles.



One way to solve the numbers problem is to create larger sets of numbers by pooling the resources of several jurisdictions to build one larger facility. Increasing the jail capacity solves other problems as well by creating more economical staff-to-inmate ratios and opportunities to provide more quality programs and services.

Although the multijurisdictional approach is sometimes problematic politically and may present difficulties with transportation, visiting, and local holding, many counties already engage in it to a minor degree through the occasional leasing of bed space on a per diem basis. Some counties find it easier to form limited multijurisdictional solutions for special, small, hard-to-manage classifications such as juveniles and women.

The National Institute of Corrections publication *Small Jail Special Issues*¹ addresses the multijurisdictional issue and references other sources on this option. When creating local classification systems, jurisdictions should consider the potential impact of a multijurisdictional approach on staffing, design, and costs.

¹ Dennis A. Kimme, Gary M. Bowker, Bruce R. Bounds, Robert G. Deichman, and Harry L. Baxter. *Small Jail Special Issues* (Washington, DC: U.S. Department of Justice, National Institute of Corrections, 1986).

Designing for Proper Separation

To design the jail for proper separation of inmates, jurisdictions should consider the following issues during the planning and design process:

- The types of inmates expected to be housed.
- The degree of separation these types of inmates require.
- Options for housing area flexibility.
- The strengths and weaknesses of different surveillance methods.
- The use of temporary holding cells.
- The use of single-occupancy cells.
- Separate housing for work release and periodic-sentence inmates.
- Privacy needs.

Inmate Types

Jail staff should identify the various types of inmates that will be detained in the new jail facility. A key part of this endeavor is to identify the types of inmates that require separate housing. Smaller jails may send these inmates to other facilities, either within the county or elsewhere.

The following inmate types should be considered for alternative housing, either in the proper type of cell within the jail or in other facilities in the community:

- Juveniles.
- The acutely mentally ill.
- Those who are suicidal.
- Those requiring medical isolation.
- Those who are acutely intoxicated.

It is recognized that most inmates, including some or all of those in the groups listed above,

must be detained at the jail, even if for very brief periods. These special needs inmates can cause a strain on space, management, and staff training needs, and a plan must be in place to deal with the requirements of these inmates in the design process. During the planning process, jurisdictions should carefully determine the probable long-term availability of outside resources for special groups before designing a jail without the capability to house them.

Degree of Inmate Separation Required

It is important to identify the degree of separation required among various inmate groups. Separation should be considered between housing areas, during movement through the facility to program or service areas, and during programs and services.

Housing area separation

The degree of separation needed in the housing area varies greatly for different groups. Physical separation may be all that is necessary between some groups of adult male populations. For example, only physical barriers may be needed to separate the high-security adult male population from the general adult male population. Sight and sound separation may not be a critical issue. On the other hand, sight and sound separation, as well as physical separation, are commonly required between the male and female housing areas.

Sound separation is required to prevent harassment between groups, eliminate undesirable communication, attain proper privacy, and eliminate disturbances between groups. Different kinds of sound might be controlled:

- Normal conversation.
- Shouting.

- Television and other artificially generated sounds.
- Impact sounds (banging, kicking, tapping).
- Noise from group movements.

Total sound separation is typically required between men and women and between juveniles and adults. Total sound separation of mentally disturbed inmates may also be desired. Sound separation between inmates, however, should not preclude or impede staff/inmate communication.

Conversational sounds can be managed by the use of solid, insulated partitions between adjacent areas (exhibit 5-3). The isolation of other sounds may not only require heavier partitioning but sound-conscious detailing of doors and other openings that might allow the transmission of sounds through corridors and shared openings (e.g., jointly used security vestibules). Total sound isolation can frequently be achieved only by locating areas requiring isolation from each other in different parts of the facility.

Sound can also be transmitted through ceiling plenums, ductwork, and electrical outlets placed back-to-back between two areas. Consequently, close review of these details is required to preclude

unwanted sound transmission, especially for high-security groups.

Movement separation

Separation during times of movement must be considered. Is it acceptable to have female inmates walk past adult male housing units and therefore have the opportunity to see and to be seen? Whether this is acceptable depends on applicable state standards and what has been deemed to be acceptable practice in the jurisdiction. However, passage through another area may not be objectionable in terms of having a disciplinary detention classification of male inmates move past other adult male housing units, even though physical, sight, and sound separation may be required between their housing units.

One way to prevent sight and sound contact during movement is to identify the basic degrees of separation desired in housing, to create appropriate clusters of housing accordingly, and to locate key program and service areas between those clusters (exhibit 5-4). Such positioning enables inmates from the various clusters to move to program and service areas without having to directly pass the housing units of the classifications from which they must be totally separated.

Exhibit 5-3. Using a Storage Area To Buffer Sound

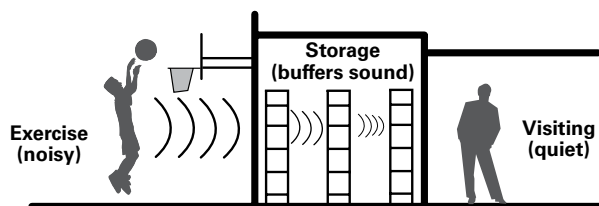
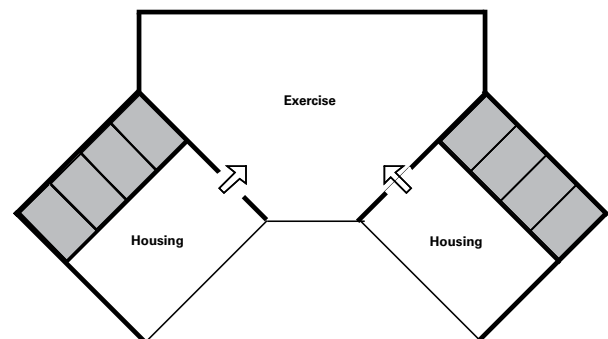

Exhibit 5-4. Program Area Located Between Housing Units for Sight and Sound Separation



Program/service area separation

Separation in program and service areas might be treated differently than separation for housing and movement or might lead to special design considerations in joint-use areas. For example, although it may be desirable to separate the housing areas of the general male population from those of the inmate worker population and to separate women from each of these, some inmates in each category might participate jointly in alcohol counseling programs or wait in a common area for medical exams, depending on classification goals and methods of supervising the activities. To some degree, proper separation might be attained through the scheduling of key activities, since the flow through these areas might be limited.

Attaining desired separation in the intake-release area is critical because all arrestees, and sometimes inmates who are being released or transferred (including inmates going to court), pass through this area. When considering the design of this area, it is desirable to plan for separate areas for the booking and release of inmates and a separate transportation area for those inmates going to court or leaving the facility. Concern here centers on attaining proper separation for the following purposes:

- Temporary holding cells for the management of loud, disruptive, violent, and medical/mental health inmates.
- Use of telephones.
- Searches (controlling contraband dumping or exchange).
- Showers and dress-out.

The design of this area is discussed in greater detail in chapter 14, “Intake-Release.”

Options for Housing Area Flexibility

Given periodic changes in population mix, it is essential that jurisdictions explore options for flexibility in housing area development. Possibilities include special management housing and/or general housing in smaller jails.

Special management housing in smaller jails

Given that some types of inmates appear at the jail rarely or infrequently, opportunities might exist for creating housing units that can serve more than one type of special management inmate. This kind of multiuse housing capability requires that the groups sharing the space not be in the facility at the same time and have similar design requirements. This might also be an option for medium-sized jails.



A key concept to evaluate is the creation of a constantly monitored special management area (exhibit 5-5). This area might consist of several small housing units that feature single-occupancy cells as well as dayrooms, showers, and so forth. This area would be separated from other areas of the jail with respect to sight, sound, and physical contact and would offer the same level of separation between individual special management units. It also would be flexibly designed to accommodate the various applicable groups.

Exhibit 5-5. Special Management Area in a Smaller Jail

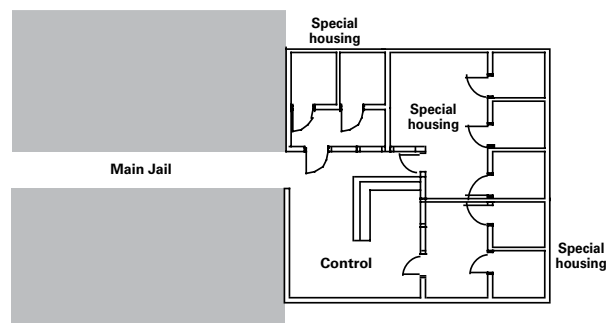

A special management area might be used for the following types of inmates, which smaller jails generally encounter only on a rare, irregular, or infrequent basis:

- Those requiring medical isolation.
- Material witnesses.
- Juveniles bound over to adult court.
- Those with physical or mental disabilities.
- Those requiring administrative segregation because they are dangerous or disruptive.
- Those needing protective custody because they are at risk from others.

General housing in smaller jails

Since the general population of a small or medium-sized jail can change considerably, it is a good idea to consider whether an area that is basically designed for low-security adult males, for example, might on another occasion accommodate high-security adult males. This type of flexibility can be accommodated in two basic ways: subdividing the capacity of the jail or planning for “swing” space.

Subdividing the capacity of the jail. Jurisdictions can subdivide the capacity of the jail into units small enough to accommodate the growth or decline of certain groups by, say, four to eight inmates simply by reassigning a couple of key swing housing areas.

Because this problem of variation seems to affect the adult male population the most, it would be wise to concentrate the entire male population into several basic units exclusive of the special housing areas. For example, where the adult male population demands a total of 64 new beds in two basic classifications, one being a general-population unit of 48 beds and the other a high-security unit of 16 beds, it might be better to

subdivide that grouping even further. Such a subdivision could be 32 beds for general population, 16 beds for high security, and 16 beds (or two groups of 8 beds) for swing space that accommodates variations in population.

Planning for swing space. Another kind of flexibility desirable in general housing relates to the need to handle the occasional overflow of female inmates. Although the female population of most smaller jails is relatively low, the size of this population will surge upward periodically, usually for short periods of time. During such times, the overflow of inmates from female housing areas must be housed elsewhere. Swing space can absorb overflow for short periods if it has been properly designed to provide the necessary separation by sight, sound, and movement.

The flexibility required by these two approaches suggests a more standardized approach to the design of furniture, equipment, and hardware.

Strengths and Weaknesses of Different Surveillance Methods

Each of the basic surveillance/supervision methods discussed earlier in this chapter has an impact on the ability to attain proper sight, sound, and physical separation between various inmate categories. Although surveillance methods are discussed in chapter 6, it is not premature at this stage to identify the surveillance methods and their various strengths and weaknesses with regard to separation.

Direct supervision

Direct supervision is a very effective approach for managing the behavior of inmates. It allows staff to be in total control of all spaces and activities within the jail. Inmates are under constant staff supervision. The principal effect of direct supervision on inmate classification is positive because it allows for the merging of some populations

that otherwise might not be housed together. For example, there may not be a need to create a medium security group and to separate it from a minimum security group. In addition, with direct supervision, there is less concern about slight variations in the makeup of the population as it changes over time.

The direct supervision model can be more difficult to implement in the smaller jail, due to the staffing levels required to directly supervise smaller groups of inmates. Some smaller jails have implemented direct supervision in one general population adult male module and used remote surveillance in the remainder of the housing areas (e.g., females and special management), due to their smaller numbers.



Intermittent surveillance

Intermittent surveillance approaches, such as those used in linear jails, do not assume that staff will observe housing units constantly and therefore place no special requirements on grouping the various units around a constantly staffed post. The use of intermittent surveillance allows housing clusters to be dispersed for physical, sight, or sound separation.

However, intermittently monitored facilities tend to have greater operational problems dealing with assaults, suicides, escape attempts, and vandalism. Consequently, if this approach is adopted in lieu of constant surveillance or supervision, the separation of inmates should be more discriminating to ensure minimal density in each housing area and physical separation of inmates who pose security or management risks. However, physical separation cannot fully compensate for a lack of staff presence. It is recommended that facilities using intermittent surveillance design the building with higher security construction.

Remote surveillance

Design that allows the constant view of inmates by staff in remote surveillance settings (commonly referred to as “podular remote” or “podular indirect” design) helps mitigate some differences in classification that call for separation of certain groups. However, although superior to intermittent surveillance in terms of reduced operational problems, remote surveillance poses a challenge to attaining necessary physical, sight, and sound separation between the different housing units under the supervision of the staff post. The presence of staff behind a barrier tends to minimize the effect of such separation problems, but it does not mitigate the fact that staff sitting in a control post or making periodic rounds through a housing unit find it difficult to manage the behavior of inmates or to take a proactive role in managing the pod.

In designing for remote surveillance, the following special concepts should be implemented to mitigate sight and sound separation problems:

- Creation of separate housing clusters for groups that require complete separation. For example, all-male clusters could be developed separate from all-female clusters.
- Control of sound through the use of solid construction consisting of security glass and concrete block or concrete wall elements instead of bar or grill cellblock faces. Not only do acoustic and physical separation demand that dayroom faces be solid, but fire codes typically do as well. Walls should extend past ceilings and above roof construction, and/or ceilings should be secure and resistant to sound transmission through ceiling plenums.
- Control of views by the manipulation of dayroom faces, dividing walls, and the use of other barriers, such as intervening corridor doors.

- Control of views by placing housing units above each other.
- Use of reflective glass surfaces in the control position to eliminate views through the control center to other housing units. Some administrators feel that the inability of inmates to see the officer through such obscured glazing has a positive behavioral influence, in that inmates never know when the officer is watching them. Such an approach is not without problems, however. Reflective glass can limit the control officer's view by creating darker, more reflective surfaces through which to look. This problem is complicated when light levels are higher in the control center than in the areas being viewed. This approach also tends to depersonalize the jail environment by hindering inmate/officer interaction.

Use of Temporary Holding Cells

The use of temporary holding cells in and around the booking area may help minimize classification problems because many arrestees are released very quickly from jail. These people include some who would require separation within the jail, such as the intoxicated and the mentally ill, who are referred to more appropriate service-providing agencies.

Use of Single-Occupancy Cells

Multiple-occupancy spaces such as dormitories reduce flexibility and the ability to subdivide the population into distinct groups. Single-occupancy cells not only improve inmate management but allow greater flexibility in limiting the capacity of any given housing unit. They also prevent inmate-on-inmate assaults during lockdown periods (e.g., sleeping hours) when staff surveillance and supervision are normally reduced.

For information on the standards and legal issues affecting the design and use of sleeping and holding cells, see chapter 27, "Single Versus Multiple Occupancy."

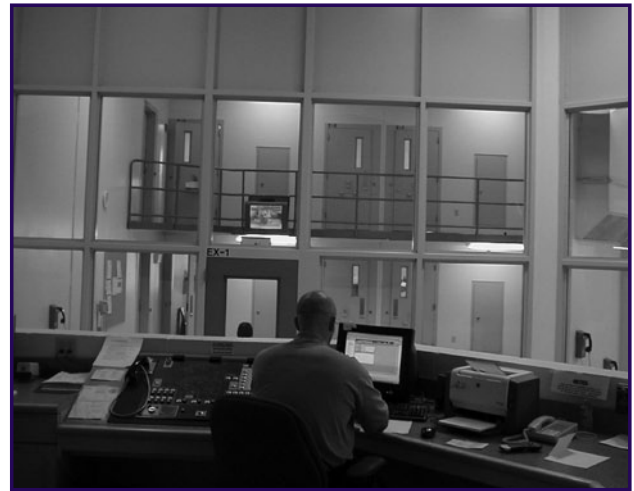

Officer in control station in remote surveillance, two-tiered housing unit. (Photograph courtesy of Liebert & Associates.)

Separate Housing of Work Release and Periodic-Sentence Inmates

Two groups that pose a special problem in terms of the introduction of contraband into the facility are work release and periodic-sentence inmates (typically weekenders). Because both of these groups of inmates leave and return to the jail on a daily or other regular basis, they have ample opportunity to obtain and arrange for the passage of drugs, weapons, and other contraband that may be desired by other inmates. When housed with other general population inmates they may be threatened and coerced to carry contraband or weapons into the facility. Consequently, inmates on work release and those with periodic sentences may share a housing unit, but it should be completely separated from the rest of the inmate population, particularly from inmate workers who, as part of their work detail, frequently move throughout the jail.

Some of the problems associated with these inmates may be handled operationally. To guarantee total separation of work release and periodic-sentence inmates from the rest of the inmate

Section 2: Major Design Considerations

population, the following design considerations apply:

- Separate areas for initial intake and release.
- Separate housing units.
- Separate entrance and exit.
- Separate visiting and recreation areas.
- Separate laundry facilities, so that contraband may not be passed into the general population by laundry workers.
- Potentially separate food staging or food service area.

These design approaches are discussed in greater detail in chapter 16, “Special Housing.”

Privacy Concerns

The issue of privacy comes into play in two ways. The first is when one inmate type passes the area of another inmate type. Of particular concern is when inmates of one gender pass the housing area of the other gender and the design is such that they can view toilet and shower areas.

This same consideration also applies in relation to staff, who must be able to supervise shower and toilet areas without unnecessary invasion of privacy. Design of the shower and toilet areas, as well as other areas with a privacy implication, must allow for the prospect that staff of the opposite gender will be working in and around the housing unit.

Chapter 6

Surveillance/Supervision

A key operational decision that has a major impact on facility design is the method of inmate supervision or surveillance to be used. Concepts of surveillance and supervision have much to do with the way in which jail spaces are organized, with the amount of time staff are in physical or visual contact with inmates, and with the number of staff required to manage the facility effectively. The degree to which the jail is a safe and secure facility in which to live and work depends greatly on these concepts and how they are translated into design.

The issue of surveillance and supervision is closely linked to the issues of classification/separation and staffing. Readers are advised to refer to chapter 5, “Classification/Separation,” and chapter 7, “Staffing Impact,” when considering surveillance and supervision.

Methods of Surveillance/Supervision

There are at least four basic approaches to observing or supervising inmates: direct supervision, remote surveillance, intermittent surveillance, and electronic monitoring. The fundamental difference between them is that the first two require the constant presence of staff and, therefore, fixed staff posts and the other two do not, thereby leaving inmates without supervision for significant periods of time (up to 60 minutes in many jurisdictions). The application of these four methods within housing units is described next.

Constant Staff Presence Required

Direct supervision

In this method, no barriers separate staff from inmates. Jail staff members are constantly positioned within each housing unit in direct contact

with inmates (exhibit 6-1). The word “supervision” is used because the staff officer can actually manage, supervise, interact with, and control inmate activities and behavior when in direct contact, rather than just watch and react, as is the case when staff members are separated from the inmates by a physical barrier.

Remote surveillance

Remote surveillance results in a facility designed with a series of podlike units that ring a central or master control station that is constantly occupied by jail staff. The staff member is outside the housing units rather than inside—that is, remote from the inmates. In this arrangement, staff are always able to look directly into the housing units or activity areas and can maintain a constant level of surveillance. However, interaction between the inmates and the control station staff is minimal. The interaction may be limited to verbal communication through an intercom, passthrough, or wire mesh or to a crude system of hand signals and window tapping. The role of the staff person at this fixed post is essentially that of observer. Direct interaction with inmates is accomplished through use of a roving officer who moves in and out of the housing area “as needed” or on an unscheduled basis.

Exhibit 6-1. Direct Supervision Housing Unit

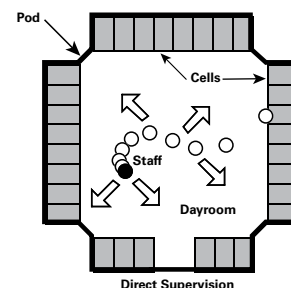

Periodic Staff Presence Required

Intermittent surveillance

With this method, staff are actually posted in a different area of the jail than the inmates and, therefore, have only intermittent, periodic contact with them, usually for minutes, or even seconds, at a time (exhibit 6-2). Although staff frequently and regularly patrol inmate-occupied areas (typically once per hour or once per half hour), inmates are largely responsible for their own behavior. In some cases, electronic surveillance is used to compensate for the lack of constant staff presence around the inmates. This method of surveillance is rarely used in new jails today and, if used, should only be used for selected low-security populations such as inmate workers and work release inmates. The key design impact of this concept is that housing unit or support space locations are not directly dependent on staff placement because staff play a minimal role in these areas.

Electronic monitoring

Consisting of closed-circuit television (CCTV) or listening devices, or both, this method of surveillance generally does not involve any frequent or routine staff presence in the cell areas, but is merely a monitoring capability from a remote

Exhibit 6-2. Intermittent Surveillance

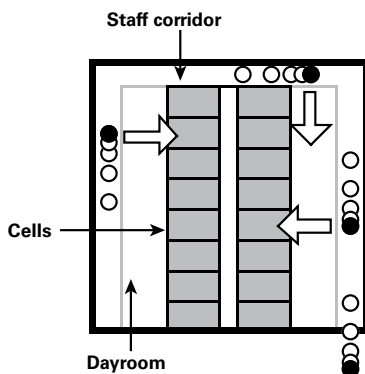

location. This method also has no direct bearing on the arrangement of space in relation to staff positions. Indeed, in extreme cases found in some older small jails, the monitoring center is not even in the same building. The limitations of such a system are well documented and include a less than desirable view of the area to be monitored; frequent vandalism, tampering, or destruction of monitoring devices in the inmate-occupied area; and poor reception on monitors due to environmental conditions.

Design Considerations

The remainder of this chapter provides design information about the four surveillance and supervision methods. The focus is on those things that have a significant impact on overall design arrangement as well as some of the details that affect the successful implementation of those concepts.

Selecting Inmate Management and Supervision Modes

The place to begin in managing the design elements resulting from surveillance/supervision modes is to match the various classifications of inmates to preferred surveillance/supervision approaches. Jurisdictions do not need to select one mode of surveillance/supervision for all types of inmates. In fact, a commitment to a single approach could be quite detrimental to the operation of a facility. Rather, it is possible, if not desirable, to use a variety of methods according to the level of control desired for each classification.

It is clear, for example, that even though direct supervision may be the most desirable form of managing general population inmates, it is probably not appropriate as the sole means of supervision for such groups as disciplinary detention inmates or inmates whose behavior poses serious dangers to staff and other inmates. Additionally,

the commitment of full-time staff to constant supervision of inmate workers or inmates on work release may seem unnecessary and is probably not practical, given the low-security nature of those classifications. Intermittent surveillance may be adequate for inmates on work release and inmate workers but have serious limitations for inmates who pose high-security risks and those in administrative segregation.

Staffing Versus Facility Durability

In considering the architectural impact of a surveillance/supervision approach, one fundamental thought about the interrelationship of staff, surveillance, and architecture should be kept in mind: Staff and the surveillance/supervision mode tend to be more critical to security than architecture.

None of the so-called state-of-the-art security hardware and materials will resist unrestrained attack. Even though security hardware and construction are meant to take abuse and contain an inmate population, they cannot provide total security by themselves. Buildings *contain* behavior, people (staff) *control* behavior. The key to security is a balance among the elements of proactive supervision (where staff and management provide fundamental security and safety), technology, and architecture.

Remote Surveillance Design

The following issues are important to consider in the use of remote surveillance design (also known as “podular remote” and “podular indirect” design) (exhibit 6-3) in housing and nonhousing areas: the number of staff posts, unwanted views between inmates, the staff view of housing areas, whether the staff post is closed or open, surveillance of movement, monitoring of support areas, sound control, lighting, and furniture and equipment.

Exhibit 6-3. Remote Surveillance Housing Pod

Overhead view of a 46-bed, double-tier remote surveillance housing pod. Cells ring the perimeter and housing control is in the center.

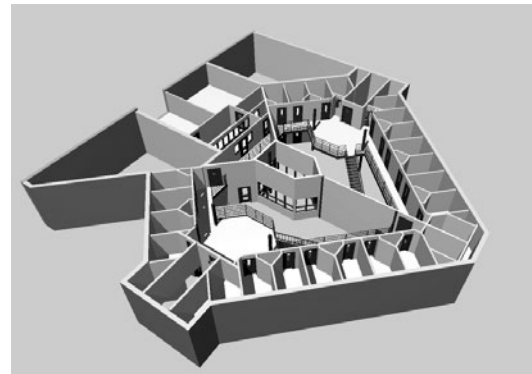

Number of staff posts

A key consideration in designing a cluster of cells for remote surveillance is identifying the number of staff posts that will be required to achieve the proper balance between security and economy. The type and number of inmates to be monitored from a single post must be carefully evaluated, as this will have a significant effect on the overall arrangement of the facility and on the degree of separation and classification that can be attained.

Unwanted views between inmates

The greatest challenge in developing the remote surveillance concept in housing is to provide officers with a full view of all areas they are expected to observe from a fixed post and, at the same time, avoid conflicts in views between the individual housing units associated with that post. The primary way to avoid unwanted views between inmates is to locate control stations so that the same staff are not required to observe inmate types that require separation (exhibit 6-4).

However, designing to accommodate minimum staffing levels frequently requires that different

Section 2: Major Design Considerations

Exhibit 6-4. Placement of Control Stations To Prevent Unwanted Views Between Inmates

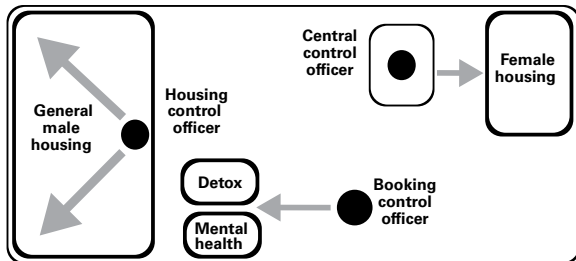

groups be situated around the same control position. In the smallest of jails, the desire may be to do this around one fixed post. Several strategies can be used to try to achieve this without creating sight and sound conflicts:

- Subdivide the corridor within the area to create visually and acoustically separate subparts.
- Manipulate the location of dayroom side and front walls to preclude side-to-side views between units.
- Consider placing housing units one over the other to preclude side-to-side view.
- Consider using mirrored glazing or a mirrored film over the glazing at the face of each unit (usually the dayroom glazing) to preclude views between different housing units in the pod. (The limitations of this strategy are noted in chapter 5, “Classification/Separation.”)

Staff view of housing areas

Not only the dayrooms of housing units need to be visible; cell interiors should also be visible to some degree, if possible. Since most new jails do not use bars on the fronts of cells, for reasons of fire safety and sound containment, the view into the cells is typically provided by vision panels (windows) in doors and/or side lights (side windows). Visibility of all cell doors is a minimum view requirement.

The concern in cell design is to strike a proper balance between visibility and privacy. The degree to which cell exposure is required depends on three considerations:

- The security level of the inmate population (i.e., low or high custody, disciplinary detention, medical housing, etc.).
- The operation of the individual units. For example, if inmates are locked out of their cells during the day and in them at night, remote visibility of the cell is less critical because staff can view everyone in the dayroom during the day and securely enter the housing unit intermittently at night to observe cells.
- Of critical importance to the officer at a remote surveillance post is the need to maintain ongoing verbal communication with inmates to ensure compliance with rules and regulations and acceptable behavior in the dayrooms, give verbal commands and instructions to inmates, and respond to inmate requests. If the officer is to maintain control, adequate means to communicate easily and clearly with inmates



View from the officer's station into a two-tiered dayroom.
(Photograph courtesy of Jim Rowenhorst.)

must be incorporated in the housing control station.

- No matter how good the visibility is into individual cells, it is still necessary for officers in remote surveillance facilities to enter the housing area and check the well-being of the inmates at regular intervals.

Closed or open staff post in remote surveillance housing

The decision to use an enclosed staff space versus an open staff space must weigh the following considerations:

- The advantages and disadvantages of having a total physical barrier between the officer's station and the inmates in the housing area corridor versus a limited barrier (normally at least a high counter).
- Lesser versus better ability to hear, smell, and see what is happening in the housing area.
- Almost total reliance on electronic means of communication versus an ability to communicate directly with inmates in a dayroom or cell at all times.
- Limited ability to provide services to the housing units versus total freedom to move around the pod to provide services and more quickly respond to inmate needs.

If the open-counter approach is used at the control post, the post may be operated somewhat like a direct-supervision housing unit. That is, there must be limits on what doors or other security features are controlled at the post to reduce the risk of harm to the officer at the post. The following measures can be used to limit that risk to the officer:

- Maintain control of the accesses to and exits from the overall housing area at master control.

- Have backup controls at master control to assume control of the area in the event of an emergency.
- Provide a means by which the housing officer can stay in constant communication with master control as he or she moves around in the housing area (e.g., two-way radios).

Surveillance of movement

The remote surveillance approach to monitoring movement requires placing fixed staff posts (e.g., master control and housing control posts) in a position that allows staff to look down key corridors. Ideally, designs will feature the ability not only to monitor corridors but also to maintain direct visual contact with other control positions within the jail (exhibit 6-5). There is also the potential here to supplement staff monitoring of inmate movement with electronic surveillance, especially for minimum-security inmates.

Monitoring support areas

Staff positions can be affiliated with support and program areas much as they are with housing units. Program area control posts do not necessarily need to be enclosed, given that they tend to serve a very limited function. However, enclosures would be required if the posts had controls that might facilitate release from the security perimeter.

Exhibit 6-5. Preferred Placement of Fixed Posts

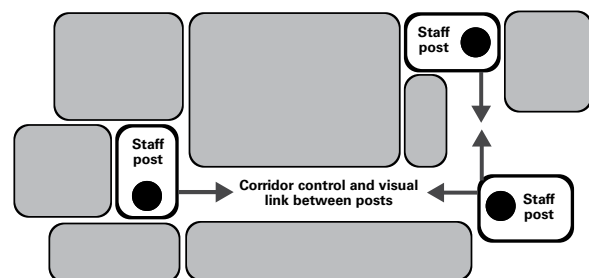

Section 2: Major Design Considerations

Because many jails do not have sufficient staff to create separate observation posts to monitor program and support areas, an important concept is to arrange key program and service areas, such as exercise and visiting, in direct view of a housing unit officer. In essence, these functions then become part of the overall design plan for the housing unit. Careful planning is necessary to eliminate potential blind spots. In addition, opportunities for officer diversion must be taken into account, especially when the officer is expected to control or monitor more than one activity.

Sound control

The control of sound—for both inmates and staff—is an important challenge for the remote surveillance setting because of the close proximity of housing areas. The principal way in which sound might be controlled is through use of solid partitions consisting of concrete masonry and security glass within each unit. However, such sound containment has the related problem of cutting the officer off from things that he/she needs to hear and from communicating with the inmates in the various housing units. The answer to this dilemma is to consider various means by which the officer can communicate:

- Intercoms between cells and the control position and between the dayroom and the control position.
- Telephones between the dayroom and the control position.
- Security openings or speaker ports in the dayroom walls through which the officer and inmate can communicate. (**Note:** Fire codes with respect to such openings must be observed, as must fire separation requirements.)

Lighting

In providing a good view to remote surveillance officers, it is important to consider the level of

lighting. This is particularly true when the staff post is enclosed. In this case, the officer is potentially looking through three glass panels and three spaces to view the inside of a cell. To minimize the amount of reflection from the glass, reduce eye strain, and increase view quality, the design should reduce the amount of artificial or natural light shining toward the officer and provide higher levels of lighting in inmate areas than in the staff area. Officer control of lighting levels is also recommended so that the officer can adapt his/her space to changing natural and artificial lighting conditions.

Furniture and equipment

Designers have felt that in selected housing units, the constant presence offered by remote surveillance allows both for less costly, nonfixed institutional furnishings to be used in place of fixed detention furnishings and for locks and hardware of a lower security nature to be used. Additionally, a lesser need for electronic surveillance, particularly CCTV, has been perceived in remote surveillance housing settings. However, the security envelope of the building cannot be compromised and must be maintained with high-security construction.

Intermittent Surveillance Design

Intermittent surveillance is not recommended as the primary method of inmate housing area control, for the following reasons:

- It essentially puts inmates rather than staff in control of the inmate housing areas, and inmate control usually results in coercion, intimidation, violence, and damage to facilities.
- It tends to limit access to activities and services because of the greater need for escorted movement.
- It inhibits the flow of information between inmates and staff.

- It creates more minor and major inconveniences for jail staff, including having to move inmates from one place to another and being required to directly supervise their work activities throughout the jail.
- It makes discipline difficult to achieve because many times the officer does not observe the rule violation and violators cannot be easily identified after the fact.

However, the following information is presented for those selected classifications and nonhousing areas of the facility that might be suitably monitored by intermittent surveillance.

Movement

One of the key concepts that shape the organization of spaces in an intermittently monitored area is the efficiency of officer movement in making rounds. Although the design benefit of the intermittent surveillance concept (particularly as it refers to housing units) is that there is much more latitude in the placement of spaces, totally random and loosely developed concepts of arrangement can make for very awkward and difficult movement patterns for the officers. Consequently, a key design consideration is how the spaces to be monitored can be arranged to allow efficient movement of the officers who must view different areas.

A critical aspect of movement patterns in facilities designed for intermittent surveillance relates to the tradition of arranging housing areas in a series of back-to-back cellblocks. These cellblocks are generally not monitored from a primary corridor but by leaving the primary corridor and entering a perimeter guard corridor around the housing units.

Monitoring cellblocks in this fashion is difficult because of the additional movement required and because the arrangement virtually precludes random, unannounced surveillance. Staff entrance

into the cellblock area is difficult to mask, because it is either quite noisy or easily visible to inmates. Remote view into cellblock areas is typically limited because the traditional back-to-back design allows nothing but a look across the cell fronts from the main corridors of the facility.

The traditional back-to-back cellblocks with a perimeter officer corridor sometimes feature more than two separate housing units in the area to achieve construction economy (exhibit 6-6). In this case, to get proper degrees of separation, one might be creating a difficult movement pattern for the officer as he/she moves through a series of doors in the officer corridor to see each separate unit. The likelihood of random surveillance is further diminished by the noise the officer makes coming through each door and such designs prevent any view of the rear units from the central corridor.

Furniture and equipment

Because housing areas monitored by intermittent surveillance leave inmates unsupervised for the majority of time, there is a critical need for

Exhibit 6-6. Traditional Back-to-Back Cellblocks

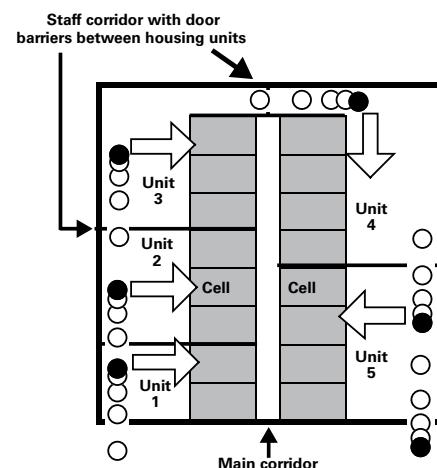

Section 2:
Major Design Considerations



Poor sitelines in a linear-designed cell block.
(Photograph courtesy of Jim Rowenhorst.)

vandal-resistant furnishings, fixtures, finishes, and hardware.

Impact of design on staffing

Experience in numerous jurisdictions has shown that two staff members are required for intermittently monitored housing units because one officer must be available to back up the officer who enters the cellblock. Because no fixed control post monitors the area, both officers are roving staff—one officer controls the cellblock from outside while the other is within the cellblock.

View conflict

Although intermittent surveillance allows for the relatively random dispersal of housing units and program spaces, designing for efficient movement creates the prospect of view conflicts. For example, a view conflict may exist because two housing units are placed across from each other off a main corridor to facilitate staff movement and observation (exhibit 6-7). The conflict may become acute if the entire face of each dayroom is glazed to allow the intermittently roving staff to have a good line of sight across the entire dayroom and a direct line of sight into each cell.

Exhibit 6-7. Inmate View Conflict

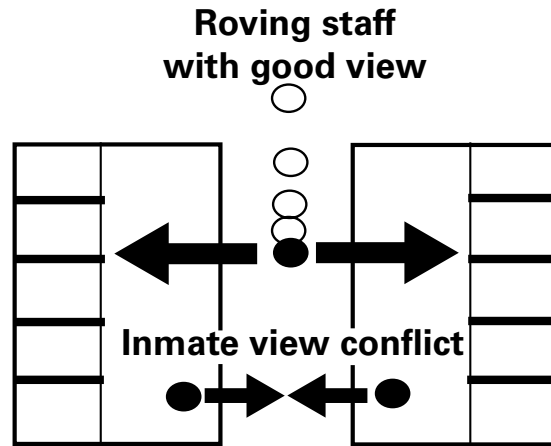

Such view conflicts are no more desirable in intermittent surveillance settings than they are in remote surveillance settings. Indeed, they are less desirable because staff are not constantly available to control the consequence of two different groups being able to see, communicate with, and signal/gesture to each other. This can result in limitations in the use of various cellblocks for inmates of noncompatible classifications.

A way to resolve a view conflict is to associate groups that could see and communicate with each other without creating a problem. However, because the need for separation may limit the potential for associating inmate groups, special design techniques might be used to limit exposure:

- Using solid-face dayroom fronts with shuttered vision panels at key points along the corridor.
- Creating entry pockets that allow the officer a good view of all parts of the dayroom from the pocket (exhibit 6-8).

Backup surveillance

Because backup electronic monitoring is essential to retaining some surveillance over intermittently observed housing or program areas, installing

Exhibit 6-8. Entry Pocket To Prevent Inmate View Conflict

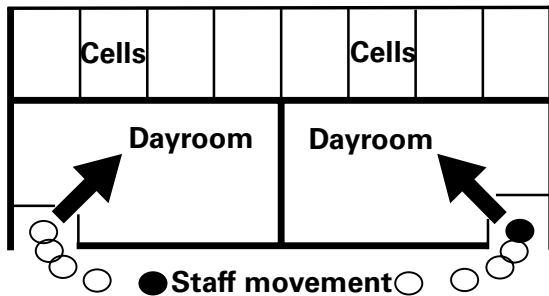

CCTV units and/or audio monitoring systems in those areas is advisable. However, to make backup electronic surveillance effective, a staff position dedicated to the task of monitoring (and not distracted by a multitude of other duties) must be created. Although a small jail typically assigns the monitoring role to master control, it must be recognized that master control functions can require the majority, if not all of the officer's attention, in even the smallest jail. (For more information on the functions of master control, see chapter 13.)

Direct Supervision Design

The direct supervision approach to inmate management has gained wide acceptance across the country as the preferred inmate management style in midsize to large jail facilities (exhibit 6-9). Incidents of inmate violence, vandalism, and disruptive behavior reportedly occur at very minimal levels in direct supervision facilities. However, in smaller jails, due to the limited size of their inmate populations, it simply is not staff-efficient to post an officer in all of the housing units. Additionally, jail standards in many states require separation of inmates according to a range of variables or criteria that place restrictions on the types of individuals who may share a common housing unit. These conditions often



Exhibit 6-9. Three-Dimensional Overhead View of Direct Supervision Housing Pod

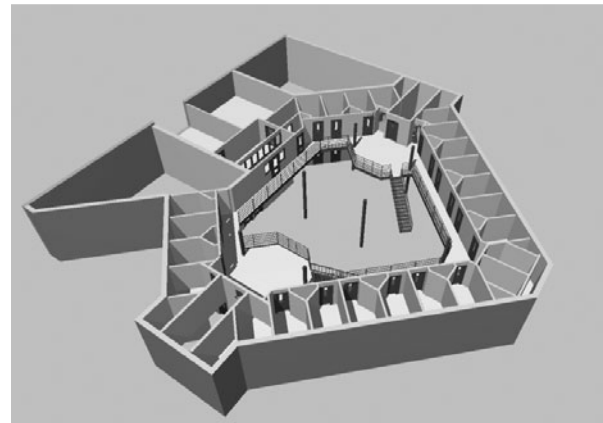

preclude the creation of larger scale housing units (usually in the 48- to 64-bed range) needed to achieve efficient staffing.

Security

Security begins with risk assessment, classification, and the assurance that a person in a direct supervision module is not a danger to staff and other inmates and is capable of responding to supervision and directions. Beyond that, a key supporting concept of direct supervision places the officer at minimal risk by virtue of the design itself. However, it is critical that the direct supervision officer has no control of entrance or egress from the unit. This greatly diminishes the benefit of inmates assaulting the unit officer and attempting to take control of the unit. Master control should control all exits from the unit.

It is also essential that the direct supervision officer be able to communicate directly with master control from any point in the housing unit. This would suggest the use of telephones or intercoms at the control position within the housing unit and mobile communication, radios, or portable telephones on the officer's person.

Section 2: Major Design Considerations

Movement

Although movement within the housing unit is not an issue, moving out of the unit to programs and services can be. By the very nature of the direct supervision concept, the housing unit officer is confined to the housing unit and cannot perform duties outside the unit. Consequently, a key idea behind direct supervision is to focus as many activities and programs as possible within or adjacent to the housing unit (exhibit 6-10). This can be done with all essential daily functions, such as dining, exercise, sick call, counseling, and visiting. Otherwise all movement outside the housing unit must be monitored by other staff unless all inmates in the unit are moving out of the unit.

Furniture and equipment

One of the benefits of the direct supervision concept is that the security features and construction of the facility can be lessened and normalized because of greater staff control, thereby reducing initial construction costs. The following furniture and equipment selections have commonly been made in direct supervision housing units:

- Nonfixed, nonsecurity dayroom furnishings.
- Nonfixed, nonsecurity stools and desks in cells.
- Low-security locks and hardware on cell doors.
- Solid wood core or lighter gauge hollow metal doors on cells (gauge mainly decided by durability considerations).
- Carpeted floor surfaces.
- More lightly constructed and reinforced partitions.
- Nonsecurity vitreous china toilet and sink fixtures.

The use of more normalized materials, equipment, and hardware is consistent with and reinforces the direct supervision concept, which in large part is based on an assumption of rational behavior by inmates classified for general population. More normative furnishings can be graduated from level to level to provide incentives for positive inmate behavior. However, even with more normalized materials, hardware, and equipment used within the housing unit, it is critical that the exterior perimeter of the housing unit be as secure as any other portion of the jail facility.

Exhibit 6-10. Colocation of Essential Daily Functions With Housing in a Direct Supervision Unit

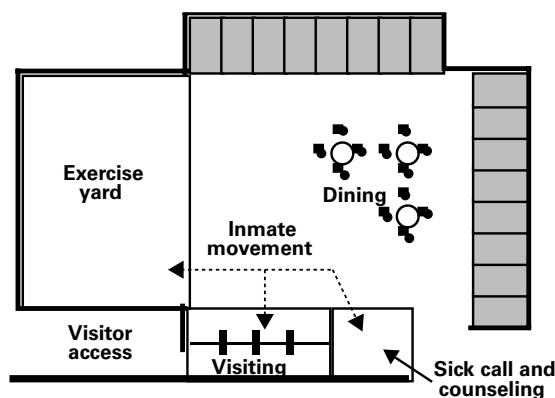

Support areas

Direct supervision has commonly been used to monitor program and service areas in jails. Control booths or observation counters are not needed outside of program and service areas. However, the agency may wish to consider providing the program staff member or officer with backup by direct surveillance from a control post or by electronic supplements such as panic buttons in the walls, voice-activated intercoms in walls or ceilings, personal radio alarm systems, and, perhaps, CCTV monitoring of program areas. Care must be taken that direct supervision is not relied on in areas that require privacy (e.g., attorney/client visiting, private counseling).

View

Although the officer is positioned within the housing unit or program area, it is still wise to provide a good view of the entire area being supervised. “Blind corners” and out-of-the-way pockets of space are problematic to direct supervision officers and are a threat to inmate safety (exhibit 6-11).

Electronic Surveillance Design

Contemporary standards encourage constant and active forms of surveillance and discourage non-constant or passive forms, such as intermittent and electronic surveillance, at least for the housing areas of the facility. Conventional wisdom also dictates that audio or electronic surveillance methods should only be used to supplement or enhance staff supervision, and not as a substitute for supervision. Following are additional reasons why reliance on electronic surveillance (CCTV or audio monitoring) is not recommended as the primary method of inmate supervision for housing areas:

- Inability to monitor areas constantly and effectively due to fatigue, preoccupation with other

activities, or too many cameras and monitors to manage.

- Almost total lack of supervision over inmates for significant portions of time.
- Initial purchase costs and repair costs related to monitoring equipment.
- Dangerous conditions created by malfunctioning or inoperable equipment.
- Lack of staff to respond to problems where insufficient staffing originally resulted in reliance on the electronic surveillance.
- Vulnerability when inmates determine what is not monitored.

However, electronic surveillance does have a role in a jail. Considering where and how electronic surveillance might supplement the basic approaches used to control the inmate population or enhance staff safety can influence the general approach to design. In general, CCTV can be suitable for:

- Monitoring building perimeters.
- Monitoring corridor movement when that movement cannot be monitored from the fixed post and/or where nonescorted movement is desired.
- Monitoring remote areas or areas not typically occupied by inmates (e.g., exits and other access points to the secure perimeter, vehicle sallyport, fire egress, stairways, mechanical spaces).
- Monitoring ingress/egress points to ascertain the identity and status of persons at those points.
- Providing backup support for selected areas (e.g., kitchens, laundry, pharmaceuticals storage, outdoor exercise areas, multipurpose rooms, and/or general housing unit areas).

Exhibit 6-11. Blind Corner

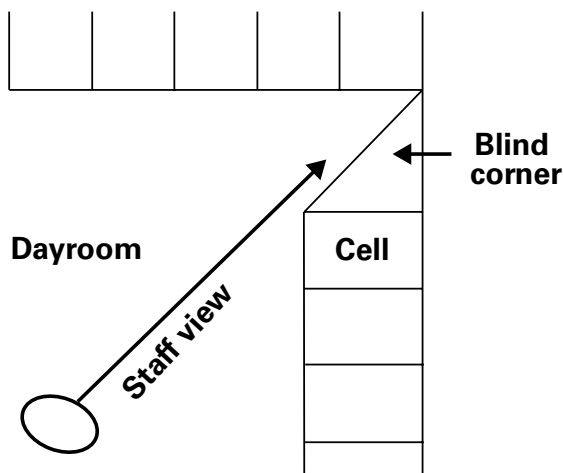

Section 2: Major Design Considerations

Color monitors provide much better resolution than black and white monitors and enhance security.

Audio surveillance and communication seem best suited to the following applications, all of which should allow inmate communication with staff:

- Two-way audio to cells, including special cells.
- Two-way audio to dayrooms/dayroom entries.
- Two-way audio to program and support areas.
- Two-way audio at ingress/egress points at internal perimeters.

In general, overreliance on the use of CCTV tends to result from a deficiency in design. It is recommended that housing areas and support areas be monitored by staff as opposed to by CCTV or audio monitoring. Electronic surveillance techniques should never be viewed as a suitable replacement for staff.

Nonhousing Surveillance

Another important aspect of surveillance/supervision methods is their impact on the supervision/monitoring of the nonhousing areas of the facility and on inmate, public, and staff movement. Surveillance of nonhousing areas may be equally significant to the design of facilities and may influence the efficiency, safety, and security of the building as much as housing unit surveillance. Key areas of inmate supervision in nonhousing areas that should be addressed in the facility design are as follows:



Black-and-white CCTV camera monitor with multiple views shown simultaneously.

(Photograph courtesy of Kimme & Associates.)

- Inmate movement to and from housing.
- Inmate visitation.
- Inmate exercise.
- Inmate program or multipurpose rooms.
- Medical services.
- Public lobby and visitor waiting.
- Loading docks/trash dumpsters.
- Public seating in attached courtrooms or video arraignment rooms.
- Areas where inmate workers may be assigned (such as laundry and kitchen).

Without adequate numbers of trained staff who are properly assigned and supervised, the jail will not be able to respond to day-to-day operational requirements or to emergency situations. Unfortunately, a poor understanding and appreciation of staffing requirements and determinants, combined with scarce monetary resources, has resulted in the understaffing of many jails.

Planners and local officials must recognize one particular finding of national studies: over the 30-year life cycle of a correctional facility, construction costs for the average, standards-compliant new jail will amount to only about 10 percent of the total combined cost of operations and construction (exhibit 7-1). This means that for every \$1 million invested in capital construction, communities will spend another \$9 million for operations over 30 years. Of this \$9 million, an average of \$7.8 million will be spent on staffing. The impact of staffing on design, and vice versa, is clearly one of the most important issues to consider in developing any new jail.

Exhibit 7-1. Average 30-Year Life Cycle Costs

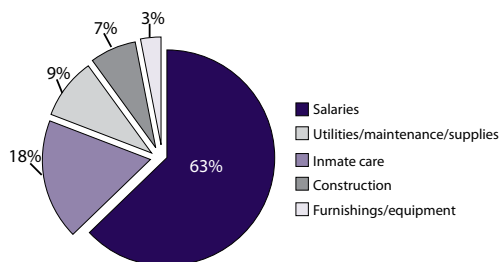

Source: Kimme & Associates, Inc., Champaign, Illinois.

The impact of staffing can be more acute for smaller jails than for larger ones because the high ratio of inmates to staff found in large jails cannot be realized easily, if at all, in smaller jails. When one considers the challenge of separating different classifications (especially by gender) and the variety of possible surveillance approaches available, the impact of design on staff efficiency and costs becomes readily apparent.

Although an indepth analysis of staffing requirements is beyond the scope of this guide, staffing analysis is an important component of jail planning. This chapter reviews the basic concepts necessary for calculating staffing by net annual work hours (NAWH) and examines how jail design can affect staffing requirements. Previous editions of the *Jail Design Guide* discussed calculating staffing using the shift relief factor (SRF) method. The primary difference between the two methods is that with the SRF method, shifts are often considered independently, which may fail to consider many categories of time off (e.g., jury duty, light duty assignments, provisions of the Family and Medical Leave Act of 1993). The NAWH method considers each job classification independently and does not calculate by shift. It also takes multiple leave factors into consideration in determining the number of hours staff are actually available to work. For a more indepth presentation on how to use NAWH to calculate staffing needs, see *Staffing Analysis Workbook for Jails, Second Edition*.¹

Readers are advised to review chapter 5, “Classification/Separation,” and chapter 6, “Surveillance/Supervision,” in conjunction with

¹ Dennis R. Liebert and Rod Miller, *Staffing Analysis Workbook for Jails, Second Edition* (Washington, DC: U.S. Department of Justice, National Institute of Corrections, 2003).

Section 2: Major Design Considerations

the present chapter because staffing, surveillance/supervision, and classification/separation are closely linked.

Legal Issues

Federal courts have made it clear that those who fund and operate jails have a duty to protect inmates from violence and to provide for their safe and secure detention. Key court decisions indicate that staff must:

- Protect inmates from themselves and from other inmates.
- Regularly visit inmate-occupied areas and maintain communication with inmates. (The timing of these visits may vary according to the type of inmate in specific housing areas, standards, and agency policy.)
- Respond to inmate calls for assistance.
- Classify and separate inmates for their own protection.
- Maintain a safe environment for inmates.
- Maintain security systems and implement procedures for the use of those systems.
- Process and supervise female inmates.
- Monitor electronic surveillance.
- Ensure that all required inmate activities, services, and programs are delivered (e.g., medical services, exercise, visits).
- Initiate contingency plans in emergency situations.

Court decisions and contemporary standards have also defined important parameters for jail operations that affect staffing through establishing:

- Minimum levels of service, such as requirements for visitation, exercise, meals, health care, and so forth.

- Policies and procedures to define and support operations.
- Prohibited practices.
- Specific required operational actions, including functions such as inmate counts, security rounds, and cell searches, that relate to the local government's duty to protect.

Perhaps most important of all, courts have repeatedly ruled that a lack of resources is insufficient reason for failure to meet constitutional minimums. Judging from past rulings, arguments that proper staffing cannot be provided because of expense will receive little support from the courts.

24-Hour Coverage

Staff costs in a properly operated jail are high because jails are so unlike other county operations. For example, although a county's administrative offices might only be open from 8:30 a.m. to 4:30 p.m., Monday through Friday, jails never close. They require 24-hour-a-day, 7-day-a-week coverage and, in some jurisdictions, same-sex staffing (that is, female staff for female inmates and male staff for male inmates).

This discussion uses the assumption that the facility operates on three 8-hour shifts. Changes to shift hours affect staffing requirements. For example, the number of staff required to fill a 24-hour post using a 12-hour shift or a 10-hour shift changes the overall number of staff needed to operate the facility. Each agency should consider the ramifications of alternate shift schedules when calculating staffing needs.

A 24-hour-a-day, 7-day-a-week post, such as master control with one officer, requires 8,760 hours of coverage for 1 year. If it has been determined that each of the staff assigned to master control is actually available for 1,752 hours a year, the

number of positions required to cover the post is calculated using the following formula: For a given post (e.g., master control), the annual number of hours of staff coverage required ($N = 8,760$), divided by the annual number of hours available per staff classification ($N = 1,752$), equals the number of staff required to fill the position: 5 staff.

Annual hours staff coverage	÷	Annual hours avail- able per staff person	=	Staff required to fill master control post
8,760	÷	1,752	=	5

Consider a post that may need to be staffed only 16 hours a day, 7 days a week. The calculations might look something like this:

Annual hours staff coverage	÷	Annual hours avail- able per staff person	=	Staff required to fill visiting clerk post
5,840	÷	1,600	=	3.7

Each jurisdiction must calculate its own NAWH when determining its particular staffing needs.

All personnel required for other functions, including those that are not 24-hour posts, should be calculated. These calculations should be realistic, given the design, and based on the tasks that need to be completed by staff.

Possible Staff Types

The kinds of jail staff for whom space might need to be included in the facility are:

- Administrator and assistants.
- Supervisors.

- Master control.
- Booking.
- Housing (officers and control).
- Movement or support security.
- Court transport.
- Clerical/records.
- Programs (in-house and/or outside service providers):
 - Work release.
 - Counseling.
 - Substance abuse.
 - Ministerial.
 - Medical.
 - Education.
 - Library.
 - Mental health.
- Food service.
- Laundry.
- Maintenance.

Jurisdictions will need to conduct a thorough analysis of their staffing requirements to determine which posts or staff types are needed on a continuous basis versus those that might be needed on selected shifts.

Design Factors

The following information addresses the primary issues planners should be concerned about when developing staff-efficient and secure jail designs: facility location, single- versus multilevel design, vertically connected posts, inmate separation, surveillance/supervision methods, circulation

Section 2: Major Design Considerations

and movement, shared activities, security perimeter, emergency response, staff backup, nature of staff posts, cell occupancy, electronic monitoring versus staff monitoring, and work environment.

Facility Location

In many cases, when the jail is located some distance from the court, full-time staff positions are required to transport inmates to and from court. Additional transportation staff may also be needed to transport inmates to doctor's visits, the hospital, or other outside appointments or between facilities.

Those contemplating building a new jail at a location remote from court facilities should consider the staffing impact and whether alternatives to in-court appearances, such as video first appearance or a first appearance court at the jail, would be feasible. Designers must also consider the following effects of frequent movement to court facilities:

- Separating the flow of inmates, the public, and court personnel.
- Searches before and after court appearances.
- Temporary court holding.
- Holding at the remote court facilities.
- Potential meal service, attorney visits, and emergency medical services.

Another staff-consuming activity is providing transportation to, and security at, medical facilities in the community. When possible, providing the ability for minor triage and treatment at the facility and the support space needed to do so will reduce the requirement to transport the inmate for medical and/or dental care and may reduce the need for additional transport staff.

Single-Level Versus Multilevel Design

A multilevel design in a smaller jail that has just 20–30 beds on each floor can drive staffing costs to unaffordable levels. For example, assuming the 24-hour-a-day, 7-day-a-week posts require 5 staff to cover each post (see calculations for master control shown above under “24-Hour Coverage”) and each floor requires a minimum of 1 post, a 3-floor jail with a capacity of 90 beds could well require a minimum of 15 housing area security staff just to meet minimum standards in some states and to ensure safety and security. To properly manage the behavior of inmates on each floor, a staff post should be staffed on each floor. This does not include administrative staff, support staff, or any other security staff such as master control, booking, and movement officers.

In addition, movement of people and services (food service and laundry, for example) can become more time consuming and complicated in a multilevel facility, particularly a small one with fewer staff. Required stairways and elevators present the jail staff with additional surveillance problems and security risks. Multiple levels also add to fire safety complications in terms of design and evacuation. Also, the potential exists for increased maintenance problems and costs (elevator service, more potential for equipment failure, and more problems in managing operations when essential equipment fails).

Multiple levels also eliminate the ability to create direct sightlines between staff posts and preclude any direct interrelationship between them unless an attempt is made at some sort of vertical connection, such as a stairway (exhibit 7-2).

Vertically Connected Posts

Any attempt to connect fixed posts on two or more levels must be carefully evaluated, as this approach has potentially serious limitations:

Exhibit 7-2. Stairway for Vertical Connection Between Multilevel Posts

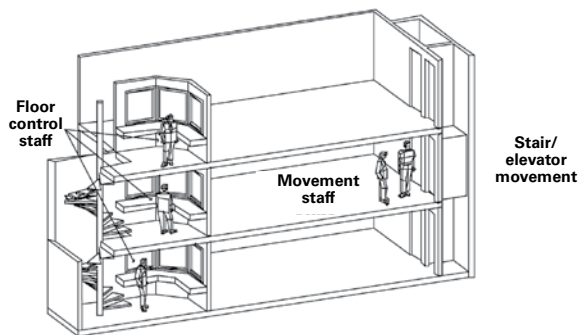

- **Loss of control.** With vertically connected control positions, the loss of one position in an assault can cause the loss of the other(s) unless special precautions are taken. These precautions (lockable hatches or doors) can complicate design and limit the actual connection between levels.
- **Insufficient staffing.** Placement of a secure control post on each floor visually linked to adjacent housing units represents a remote surveillance form of design. Yet if cost-saving measures result in only one officer moving vertically from one floor's observation post to another to control both floors, the design compromises the benefits that make the remote surveillance approach superior to intermittent surveillance (i.e., continuous observation of the inmate population and immediate intervention during conflicts and altercations).

Additionally, staffing control posts on multiple floors with one person becomes problematic when staff are needed simultaneously on two levels (e.g., to unlock doors or back up roving officers).

Inmate Separation

The extent to which inmates are separated in the facility and the manner in which separation is

achieved can translate into staffing requirements. The need to separate inmates is addressed in all standards and is discussed in an earlier section of this document. Often, the greater the number of distinct housing units a facility has, the more staff are needed to supervise the units.

The types of inmates to be housed in the facility can also dictate the types and number of staff needed. A facility that houses both male and female inmates, for instance, should have both a male and a female jail officer on duty at all times and space for both genders (posts, lockers, showers, and so forth).

If the jail has a long-term population, more programs and services, such as exercise, visitation, work release, education, counseling, and mental health services, will require additional staff to administer those programs. A facility that primarily detains violent felons and career criminals requires more intensive staffing than one that houses nonviolent misdemeanants such as drunk-driving and minor property offenders.

Decisions on inmate separation, housing types, and staffing levels should be based on the collection and analysis of data very early in the functional programming phase of the project.

Surveillance/Supervision Methods

The method of surveillance or supervision selected for housing and nonhousing functions has a direct bearing on staffing needs. Remote observation and direct supervision methods, for example, require constant staffing and clear sightlines from established staff positions, as discussed in the preceding section. The implications of limiting the movement of staff (and thus the tasks that can be performed) in a remote observation setting versus the freedom of movement and flexibility staff have in a direct supervision setting must be carefully evaluated. It is not necessarily true that remote observation facilities require fewer staff than direct supervision. If the goal is

Section 2: Major Design Considerations

to manage the behavior of inmates, there is still a need to provide sufficient staff to make continuous and frequent contact with inmates. Remote observation may add another layer of surveillance, but it does not take the place of staff contact in managing inmate behavior. The added ramification of monitoring needed separation according to classification is significant.

Circulation and Movement

Jail operations require constant movement within the security perimeter by staff and inmates. Inmates move to and from activities and services, and staff are constantly moving to provide basic supervision and security. Additionally, the public enters the facility for a variety of purposes, including visiting, securing someone's release, picking up property, and providing programs and services.

Controlling movement within the jail is an essential and staff-intensive ingredient of security. The design of the facility can either enhance or inhibit effective movement control and will influence the need for staff. For example, complicated staff circulation patterns for surveillance rounds can diminish staff efficiency and safety and reduce the chances that rounds will be executed as frequently and effectively as necessary. The following key design considerations regarding movement and circulation are discussed below: simplicity, corridor width, functional relationships, housing area linkage, unescorted movement, and public movement.

Simplicity

It is desirable to keep circulation corridor patterns simple and to minimize the number of levels (exhibit 7-3). This makes movement more direct as well as easier to observe and supervise.

Corridor width

Corridors should be designed with ample width to accommodate the movement of food and

Exhibit 7-3. Simplified Circulation Corridor

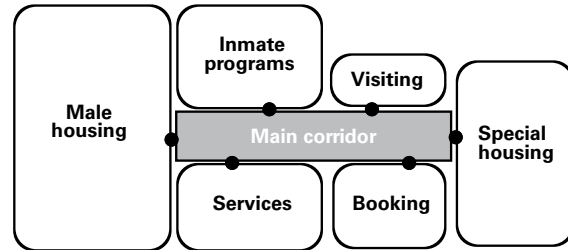

laundry carts, officers escorting inmates through the facility, and people passing each other in the corridor. Corridor width should also be sufficient to allow doors to swing into the corridor without blocking egress or flow. It is recommended that primary corridors be at least 8 feet wide.

Functional relationships

Arrange functional components according to their use and their users. For example, since inmates eat three times a day, a convenient location for food services that permits efficient delivery of food to the pods and the return of trays and refuse to the kitchen becomes important to staff. On the other hand, since the commissary is probably used once or twice a week, its location is less critical.

Housing area linkage

Identify services and programs that occur frequently, such as exercise or visiting, and locate them in or adjacent to housing units. This allows already established staff posts to monitor movement to the activity and the activity itself. This strategy is particularly applicable to remote surveillance and direct supervision housing areas.

Unescorted movement

Identify the need for surveillance of inmate movement between inmate areas and plan for unescorted movement wherever possible. Identify whether any of these design possibilities exist:

- Movement directly monitored from constantly staffed posts.
- Movement monitored by electronic means such as closed-circuit television (CCTV) and audio.
- Unmonitored movement (i.e., where housing officers issue passes to low-security inmates that permit them to move to agreed-upon areas in the secure perimeter, such as to programs or medical facilities).

Public movement

Minimize the need for public/visitor movement within the facility, especially within the security perimeter. Public/visitor movement presents special security problems that can only be solved by staff presence or electronic surveillance. Use the facility design to create locations at which visitors can conduct business without entering the security perimeter (e.g., a security passage or video visitation area).

Shared Activities

Monitoring inmate activities outside of the housing unit can be quite time consuming, so it is advantageous to identify which groups might participate safely together in various activities (e.g., visiting, exercise) and to design space accordingly. Designing space to accommodate larger groups of inmates for exercise rather than smaller groups would save staff time. For example, if eight different housing groups could be safely combined into four groups without sacrificing important classification considerations, and each of the four groups exercised separately for 1 hour daily, 4 hours of staff time would be saved daily.

An alternative to moving inmates to activities and programs is to provide multipurpose rooms and exercise areas adjacent to housing units that can be accessed directly from different housing

units. The room can be used for shared activities and programs or individually by one housing unit, depending on the classification separation issues. Programs and activities may in some cases be held in dayrooms as well. Each of these options provides an alternative to moving groups of inmates within the facility.

Security Perimeter

Every jail should have a well-defined security perimeter with each point of entry controlled through a security vestibule (a set of two interlocked doors that can be opened in unison only in an emergency). All exterior windows and other potential means of egress from the security perimeter must be secure. The weaker the security perimeter, the more staff it will take to control and supervise inmate movement and housing (see chapter 8, “Security Perimeter”).

Emergency Response

A constant minimum level of staffing is required to accomplish three key activities during an emergency:

- Respond to the scene and implement intervention and/or suppression procedures (e.g., break up disturbance, put out fire).
- Evacuate the housing area or the entire facility promptly and safely.
- Provide containment and continuing inmate supervision after evacuation.

The design of the facility and delineation of evacuation routes and holding areas have critical staffing implications for emergency response.

Material and equipment choices are of critical importance with respect to detection and containment of fire and smoke, exhaust of toxic fumes, and quick evacuation. Equipment that allows cells to be remotely unlocked in groups, with egress routes monitored, is recommended.

Section 2: Major Design Considerations

Places for temporary and long-term containment, to which inmates would evacuate and be monitored, must be quickly and securely accessible in order for staff to function effectively (exhibit 7-4).

The National Fire Protection Association (NFPA) *Life Safety Code*² and local codes should be referred to for more information on safety precautions and evacuation. The state fire authority and local fire chief or fire marshal should be contacted for guidance on this issue.

Staff Backup

All jails must plan their staffing levels to accommodate backup for emergencies, especially in direct supervision and remote surveillance facilities, because in those facilities, the officer who supervises or provides surveillance for the inmates is at a fixed post and cannot leave that post to provide assistance. Obviously, the master control officer or the housing control officer's inability to provide direct assistance eliminates the possibility of direct intervention. However, he/she does play an important inmate observation and support function for responding staff by:

Exhibit 7-4. Evacuation Routes

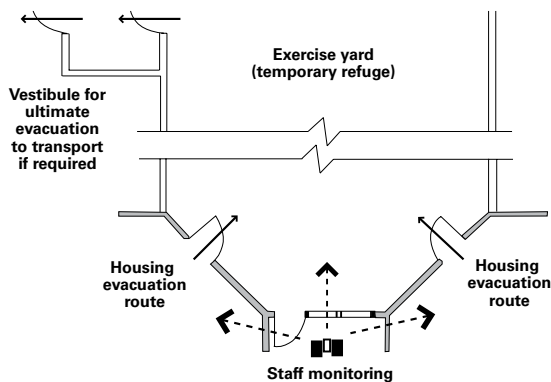

² National Fire Protection Association, *NFPA 101®: Life Safety Code*® (Quincy, MA: National Fire Protection Association, 2009).

- Providing a psychological deterrent to further misbehavior by his/her presence.
- Monitoring and witnessing illegal behavior and, therefore, guaranteeing successful prosecution of offenders.
- Serving as a communication link to obtain assistance from other personnel outside the immediate area of the jail, including nonjail sheriff's staff, municipal police, and fire department and ambulance personnel.
- Directing the appropriate intervention.

Designing Staff Workstations

When a facility features a staff post for housing control (other than master control), a major design and operational question is whether to fully enclose and secure the post or to leave it an open, counter-like area, as discussed in chapter 6, "Surveillance/Supervision."

The open-counter area is much more versatile from a staff point of view, allowing the officer to move freely from the post to perform duties and services other than those demanded within the post itself. Such versatility potentially distributes work better, improves supervision by allowing better and more frequent inmate contact, facilitates two-way communication between staff and inmates, and minimizes the need for additional staff. Without careful planning and design, however, the open design can lead to security compromises.

The following questions should be considered when determining the design of a staff post:

- Can tasks be performed more efficiently from a post that restricts staff movement or one that enhances staff movement and flexibility?

Staff Backup in the Smaller Jail



In many smaller jails, a single master control officer will be able to observe most inmate housing areas from a remote, fixed post. However, that staff member's ability to physically respond, unassisted, to incidents such as assaults, medical emergencies, or escape attempts may be severely limited by a need to retain control of the secure post and by concerns for his/her own personal safety. Although that officer cannot respond directly to a problem, he/she is able to provide direct visual backup assistance to officers who do enter the housing units or other inmate-occupied areas.

Unfortunately, it can be assumed that numerous small jails may be staffed with two-person, male/female teams on each shift, with one officer in a secure master control station and the other in a roving capacity. Given the need to maintain the security of a master control room, the officer can ill afford to leave it to render assistance. Therefore, his/her chief tool in providing backup assistance is an unobstructed view of all inmate-occupied areas and communication linkages through which to interact verbally with inmates and, most critically, to summon outside assistance. However, if outside assistance, such as from law enforcement personnel in adjacent areas of the facility, is not immediately available, this two-person approach becomes quite problematic when serious problems arise. The goal should be to provide backup for any staff member in any area of the jail, with the desired approach of providing sufficient staff within the secure perimeter at all times. If this is not achievable, the alternative option of using sworn law enforcement staff who are available at any time from an adjacent, attached building may be considered.

Through this team approach, which combines direct interaction of the roving officer with the backup of a master control officer and outside assistance, the well-designed small jail can respond to most occurrences without creating excessive risk to staff or inmates.

- Is backup security available to reduce the risks of an open-counter arrangement?
- What is at stake if the post is lost?
- What is the impact on inmate surveillance and supervision if the post is opened or closed?
- What level of inmate contact and communication is desired?
- Do staff have the ability to communicate with other staff in the area?
- What are the potential staff savings?

The open-counter housing post is not viable unless the jail maintains a secure master control room with complete override capability on all security systems and full control of the perimeter of the housing area.

Cell Occupancy

Although there is no irrefutable evidence that single-cell jails are less costly to staff than facilities with multiple-occupancy cells, there are strong arguments that single-cell housing results in more efficient use of staff. These arguments generally include the following:

- Multiple-occupancy housing greatly reduces the staff's ability to prevent physical or sexual assaults, especially during night lockdown, when staffing levels tend to be reduced. Multiple-occupancy housing may eliminate the ability to reduce staffing at night.
- During a disturbance in a multiple-occupancy cell, the staff's ability to take full control of the incident is reduced due to the inability to fully separate combative inmates.
- Multiple-occupancy cells diminish staff's ability to maintain discipline and control because vandalism is difficult to attribute to individual inmates.

Section 2: Major Design Considerations

However, these arguments assume a limited measure of control on the part of the officer and/or the absence of staff in the unit during most of the day and night (remote observation or linear surveillance). A well-run housing unit, with a staff member present 24 hours a day, that is designed to provide the maximum amount of vision into all areas of the unit will generally mitigate or eliminate the concerns expressed above.

Electronic Monitoring Versus Staff Monitoring

Audio monitoring and CCTV have their place in the jail security system, but such equipment is effective only when staff are provided to monitor the systems and summon assistance. Often, surveillance equipment is installed, but staffing is not appropriately allocated to monitor it, thus compromising its effectiveness. In addition to the staff assigned to monitor the electronic systems, other staff must be available to respond to inappropriate inmate behavior detected by the electronic surveillance. Personal supervision by trained staff should be provided in all jails, regardless of the electronic tools used to supplement it. Electronic monitoring should be used to enhance rather than supplant staff functions. The appropriate blending of staff and technology should be reinforced during the transition process.

Work Environment

A key fact to remember when creating the jail environment is that it is not only an inmate environment but a staff environment. Buildings *contain* behavior. Staff *control* inmate behavior.

Indeed, the jail is more of a staff work environment, in that the average officer works in the facility over a period of years, whereas the average inmate stays only about 15–25 days.

Additionally, jails often experience a major problem with staff turnover. Much of it has to do with salary and career opportunities, but some of it has to do with very poor and stressful work

conditions in older jails. Consequently, designs developed with staff in mind may help eliminate this trend and even set in motion improvements in other areas.

Staff-oriented considerations include the following:

- Personal safety and security.
- Ease of movement and ease of general job performance.
- Pleasantness of environment:
 - Natural light.
 - Artificial light.
 - Sound.
 - Color.
 - Ventilation.
- Control over personal environment, especially staff posts.
- Amenities.
- Lockers and showers.
- Training areas.
- Lounge/break room.
- Exercise facilities.
- Parking.

Conclusion

It is important to remember that the design of the facility can greatly enhance the ability of staff to do their jobs effectively and safely. Conversely, a poorly planned facility can create problems with facility operations and the management of inmate behavior. Spending the time to develop a well-thought-out operational plan and working with the planners and architects to design a facility

that achieves the goal of safety and security for staff and inmates is the key to developing a facility that can be safely operated using an appropriate number of staff.

It is also important to remember that there is no one-size-fits-all staffing plan, and it is incumbent

on each agency to take the time necessary to collect accurate and complete staffing information to ensure staffing decisions are made based on desired operations for the new facility and real data that can be used to justify those decisions.

Escape and contraband are deeply troubling words to sheriffs and jail administrators. They represent the manifestation of basic security defects within the jail's physical plant or problems with its operation. New jail design approaches, hardware technology, and improved training for jail staff during the recent past have reduced, but not eliminated, problems of escape, contraband passage, and related breaches in jail security.

Many breaches in jail security result from human error in recruitment, selection, and supervision of jail staff or a lack of adequate training and written policies and procedures. Some escapes early in the life of a new jail occur because staff were inadequately trained in the new building's control equipment, which is frequently more complex than that found in the old jail. However, even the most elite correctional staff cannot be expected to make an inadequately designed and equipped jail consistently secure through staff effort alone. They must rely, to some extent, on the integrity of the materials, hardware, and design to complement effective security procedures.

The failure to define and establish, through planning and design, a clearly identifiable and reliable security perimeter (envelope) is a primary contributor to problems in small and medium-sized jails. Architecture, operational procedures, and technology are elements of jail security. Equipment, materials, and design decisions are influenced by the nature of the inmate population and are oriented toward basic security objectives. This chapter describes an overall approach to security and recommends measures to enhance jail security.

Ingredients of Security

Security systems engineers and analysts have identified four major ingredients involved in providing building security: denial, detection, response, and assessment.

- **Denial.** In practical terms, denial means that the building is designed to restrict inmate access to unauthorized internal areas or the outside; provide physical separation for various inmate classifications (e.g., separate housing for inmate workers); control inmate movement through the use of sallyports, staff supervision, and other means; and eliminate the potential for the passage of contraband in the jail by building and maintaining a secure perimeter.
- **Detection.** If the denial element fails or is compromised (e.g., a lock malfunctions or security glass is penetrated), then detection is necessary. Detection in jails often comes about through regular inmate counts or random cell checks and searches that reveal an escape or contraband. Detection might also mean that an officer observes an inmate scaling a fence or bolting through a door to an unsecured area. In modern jails, detection can involve sophisticated technology such as perimeter-sensing devices to detect attempts at escape or intrusion.
- **Response.** After detection and assessment, the response is the action taken by staff to counteract the problem. In addition to sending staff to the affected area, this may include triggering alarms, lighting selected areas, closing gates, and initiating evacuation procedures.
- **Assessment.** Assessment is simply an evaluation of the problem that has been detected. It is largely a matter of determining the nature

Section 2: Major Design Considerations

and degree of a situation (e.g., escape attempt, window tampering, unauthorized movement in a secure zone). Assessment may or may not be made with the assistance of sophisticated technology.

Design Focus

The focus during jail planning is on the fundamental design features and the staffing required for effective denial, detection, response, and assessment. Detection, response, and assessment primarily require the involvement of staff, supplemented by technologies such as closed-circuit television (CCTV), motion detection, audio monitoring, and remote control of locks, lights, and alarms. Staff can be helped to effectively do their job in these areas by operational decisions and building designs that use constant and effective staff surveillance or supervision of all inmate-occupied or inmate-utilized areas, routes of egress, and the exterior of the facility.

This chapter is devoted to the fundamental design features that provide the ingredient of denial. Denial of escape and contraband passage is fundamentally accommodated in the design of the physical plant in the following ways:

- Creating an overall barrier, commonly referred to as a “**security perimeter**,” that precludes contraband passage from the outside and unauthorized access to and egress from the jail.
- Creating **internal security zones** that preclude escape and contraband passage within the jail by controlling internal movement and maintaining separation between key activities and inmate-occupied areas, especially those that house inmates who pose the greatest risk of escape or contraband passage according to the facility’s classification plan. (See chapter 5, “Classification/Separation.”)

Perimeters and Zones

The different kinds of perimeters and zones that might be created to assist staff in denying escape and contraband passage are described below.

Main security perimeter

The main security perimeter is the fundamental barrier that is intended to preclude escape, unauthorized ingress or egress, and contraband passage. It might best be thought of as a security envelope because the main security perimeter is a three-dimensional rather than a two-dimensional element. That is, it consists of the ceilings, roofs, and floors, as well as the exterior and interior walls, doors, passthroughs, and windows, which help deny escape or contraband passage from the outside.

Secondary security perimeter

The secondary security perimeter is a wall, security fence, or other support elements that complement the main security perimeter of the jail. This element normally consists of fences that define large outdoor exercise or farm and garden areas and that inhibit (though not necessarily prohibit) access to the main security perimeter. It may also consist of walls that create controlled exterior spaces to preclude view as well as inhibit access. These perimeter fences and walls do not create a three-dimensional security envelope.

Primary internal security zones

Primary internal security zones are three-dimensional areas within the main security perimeter that provide for basic security separation and control of primary movement routes within the jail, denying or delaying access to other zones. Typical examples of primary security zones in a jail include:

- Master control.
- Housing pods or areas.
- Female housing areas.
- Special housing areas, especially those for work release or periodically confined inmates.
- Program and support service areas.
- Visiting areas, especially those accessible to the public.

Access to these zones is typically controlled remotely by master control. In some cases, selected primary internal security zones coincide with fire and smoke containment zones within the overall structure.

Secondary internal security zones

Secondary internal security zones are three-dimensional areas within both the main security perimeter and the primary internal security zones (exhibit 8-1). Their purpose is typically to preclude unauthorized and uncontrolled access between functional components (e.g., laundry and food services) or between areas that are part of functional components (e.g., separate housing units) within a primary internal security zone. Access to these zones is typically controlled remotely by master control or either remotely or directly by other facility staff.

Exhibit 8-1. Secondary Internal Security Zones

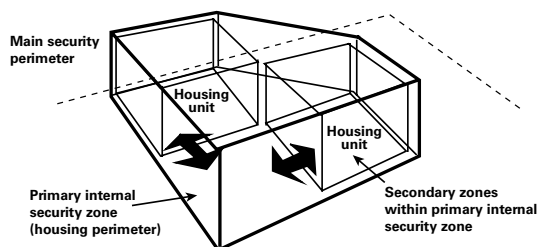

Zoning may go to a third level because individual spaces, such as cells and medication storage, frequently require fully secure protection from outside intrusion, escape attempts, and uncontrolled access within a secondary internal security zone. These spaces might be referred to as “tertiary internal security zones.”

Building Areas Outside the Security Envelope

The overall building envelope is virtually never the same as the security envelope of the jail. There are functions outside of the jail security envelope that often share the building and contribute to the effectiveness of jail operations. Typically, these include the sheriff’s law enforcement functions and, possibly, court and probation functions. For these nonjail functions to share the building with the jail effectively, their needs must be recognized, their interrelationship with the jail understood, and their components integrated into the design in a way that avoids security conflicts. These issues are examined more closely in chapter 9, “Criminal Justice Interface.”

Jail-related functions that need to be outside of the primary jail security envelope (like the lobby or jail administration) also share the overall building envelope (exhibit 8-2). Access to some or all of these areas may be controlled by jail staff within the security envelope.

Exhibit 8-2. Relationship of Overall Building to Main Security Perimeter

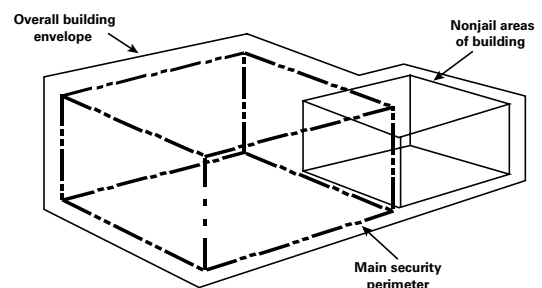

Section 2: Major Design Considerations

The most common functions affiliated with the jail, but outside its main security envelope, are the public lobby, the night lobby/vestibule, and the jail administration and staff areas (these can be provided in association with the law enforcement area). These public areas require different levels of access control. Nonjail spaces should be grouped depending on the type of access control required:

- **Uncontrolled public areas.** These areas consist of spaces to which the public has unrestricted access, although they may be monitored by direct observation from a constantly staffed post and/or by electronic means (CCTV and/or audio). Spaces that frequently fall into this category are the main lobby and its affiliated spaces (e.g., public restrooms, property locker areas) and the night lobby/vestibule.
- **Periodically controlled areas.** These are areas to which the public has unrestricted access only during portions of the day. At other times, access is precluded and controlled by jail staff (usually master control) or by law enforcement staff (normally the dispatcher). The public lobby and its affiliated spaces can fall into this category, especially when a night lobby/vestibule is incorporated to accommodate unrestricted public contact after visiting and office hours.
- **Controlled access areas.** These are areas to which public access must be controlled or restricted at all times. The jail administration area is the main example of a set of spaces to which the public must have access only in a controlled and regulated way. The staff spaces (lockers, training, and exercise) are normally within this area because public access should be restricted.

Design Considerations

Following are design considerations for the development of the main security envelope and the internal security zones essential to the denial of escape, unauthorized access, and contraband passage. More information on the security development of different functional components and spaces within functional components can be found in section 3, “Functional Components.”

General Considerations

Overlapping perimeters/zones

Because of the nature of internal zoning, the floors, walls, and/or roof areas that define internal zones and the main security envelope frequently overlap. For example, the exterior wall of an individual cell, which may be defined as part of a tertiary internal security zone, is frequently also the wall of the housing unit (secondary security zone), the general population male housing area (primary security zone), and the jail as a whole (main security envelope). In such a case, it is critical to design the wall according to the needs of the most stringent security condition—in this case, those of the main security envelope.

In the same example, however, the ceiling of the cell might not coincide, or overlap, with that of other zones. This is because the security demands of the cell, or tertiary zone, might require the use of a securely constructed ceiling (concrete, steel, cement plaster on metal lath) that precludes access to a roof system above. If the roof system is securely constructed, it may serve separately as part of the main security perimeter or part of a secondary or a primary security zone. In another instance, the cell may be located under another cell sharing the same two-tier housing unit, or under a floor of another internal security zone.

Impact on design

The primary reason for establishing a main security perimeter (envelope) and internal security zones is basic facility safety and security. However, an important architectural and economic benefit also accrues: development of a sound security envelope and effective internal zones allows wider latitude in the development of individual internal spaces in terms of material finishes, hardware, and furniture selection. This is especially true when perimeter and zoning concepts are coupled with a well-developed classification/separation plan and with concepts of constant staff presence and surveillance, thus providing detection, assessment, and response capabilities.

For example, if the main security envelope and the primary internal security zone of a housing area consisting of several housing units are well defined and properly designed, as well as constantly observed by staff, some of the following options and associated cost savings might become available.

- Less heavily reinforced and constructed partitions and less costly security glazing to separate housing-unit dayrooms from the zone corridor because the zone is clearly defined and controlled, offering little gain to inmates penetrating the wall.
- Less costly doors, frames, hardware, and locks on general-population cells because there is little to be gained by penetration.
- Less costly dayroom ceiling materials because penetration offers no viable escape route from the zone.
- Elimination of costly security vestibules at the entry to housing units because escape from the individual unit is contained within the primary housing area security zone.

- Elimination of costly enclosed housing control posts because assaultive behavior by inmates will not result in egress from the primary housing area security zone.

In evaluating these types of options, the issue of durability should not be neglected, nor should it be forgotten that physical security is still a required ingredient. From an operational viewpoint, good perimeter and good internal zoning may also allow for unescorted inmate movement between different points in the facility without fear of a successful escape attempt. An example would be unescorted movement between housing and visiting zones.

Master control

A key consideration in the development of an effective security envelope and effective internal security zones is creation of a master control position. This position, which must be a primary internal security zone in its own right, must be able to:



Housing unit within the secure perimeter and primary internal security zone with solid-core wood doors, nonfixed furnishings, and open officer's station.

(Photograph courtesy of Voorhis Robertson Justice Services.)

Section 2: Major Design Considerations

- Monitor all security systems (e.g., CCTV, alarms, pressure-sensitive motion detectors).
- Communicate with, control and monitor, and observe people at all ingress/egress points in the main security envelope.
- Communicate with, control and monitor, and observe people at the doors or gates that help define internal security zones and inhibit movement between them.
- Communicate with facility staff, wherever they are located in the facility.
- Control entry into the master control space.
(**Note:** An emergency key should be kept outside the facility's security perimeter to open the room if the officer becomes incapacitated.)
- Facilitate efficient staff and inmate movement throughout the facility.

More on the design of this space can be found in chapter 13, "Master Control."

Compatibility of construction

In creating the security envelope and internal security zones, it is important that materials, finishes, and hardware in perimeter and zone barriers are compatible and comparable. For example, it is not helpful to provide glass-clad polycarbonate glazing material (a very high security window material) when the base wall consists of gypsum board (standard drywall). Similarly, it is inappropriate to provide a high-security lock for a lightweight hollow metal door and door frame. Other incompatible elements are concrete floors and reinforced concrete masonry unit walls combined with lightweight suspended metal acoustic ceiling panels that lead to unsecured ceiling plenums (the space between ceilings and roofs).

Security above the zone

One often-overlooked consideration in the development of the security envelope and internal

security zones is security above the space or area that is being defined as a zone or envelope. Failing to realize that the envelope and zones are three-dimensional, planners often give inadequate attention to the development of the ceiling in relation to the ceiling plenum and the roof as a key element of the envelope or zone. There are several considerations in this regard:

- The ceiling of a space should be securely constructed if the walls around the zone do not extend to the roof or construction above and/or if the roof or construction above is not secured (exhibit 8-3).
- The ceiling should be securely constructed regardless of the nature of the roof or construction above and regardless of the degree to which the walls exceed the ceiling line if elements in the ceiling (e.g., electrical lines, water lines, ductwork) need protection or if access to the plenum is intolerable under any circumstance.
- Openings in a secure ceiling should be sized and designed to preclude unwanted penetration.

Main Security Envelope

The following design considerations apply to the main security envelope of the jail. The main security envelope must assist in denying escape

Exhibit 8-3. Security Ceiling

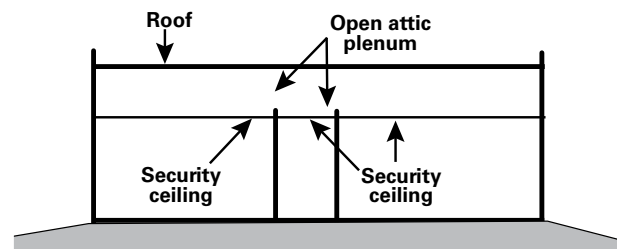

and contraband passage and must be constructed with the assumption that extremely dangerous and sophisticated criminals may be held in the jail. Escape and contraband passage are constant risks that can be initiated by individual inmates or in conjunction with outside collaborators. The preservation of a safe environment inside the jail and the prevention of assisted escapes or contraband passage from the outside require strict control over all penetrations of the security envelope.

A variety of design considerations to prevent escapes and contraband passage pertain to the development of the main security envelope:

- **Limited access points.** The number of access points must be limited to the minimum necessary for the efficient operation of the building, separation of conflicting traffic flows, and compliance with life safety codes. The fewer entry and exit points into the building, the fewer chances that security at these areas will be compromised. Minimum access points needed in a security perimeter to properly control traffic flow and satisfy codes include:
 - Main public access to visiting and program areas.
 - Staff access to the perimeter, which may be the same as the public access, although this may not be desirable.
 - Arrestee/arresting officer access.
 - Access for delivery of food/supplies and garbage removal.
 - Required points of emergency egress.
- **Security vestibule with interlocking doors.** All access points into the main security perimeter should be through a security vestibule with interlocking doors that allow for override of the interlock by master control during an emergency (exhibit 8-4).

Exhibit 8-4. Security Vestibule

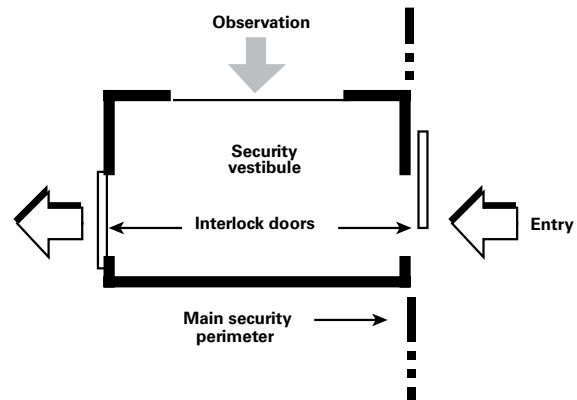

- **Key override capability.** Access points into the main security perimeter should have a key override capability. Keys to these doors should be under the direct control of the master control officer and should never be removed from the master control area except in an emergency. However, it is sometimes desirable to keep a master key in a secure location outside the secure perimeter (most frequently the sheriff's office) in case of an equipment failure or other emergency in master control.
- **Metal detectors.** Metal detectors should be available at all access points used by the public and outside service providers and, depending on the policy of the jail administration, at access points used by jail staff and other officials. Metal detectors can be integrated into the architecture of the facility in ways that hide them from view. Although the integrated detectors may be more visually appealing, the use of freestanding or hand-held detectors might be more of a deterrent at access points.
- **Secure construction of access points.** All access points should be securely constructed. Following are some examples:
 - Swing or sliding doors of 12- or 14-gauge steel.

Section 2: Major Design Considerations

- ❑ Frames grouted and anchored securely to the wall.
- ❑ High-security detention-grade locks and hardware.
- ❑ Windows, if used, that employ the strongest security glass products.
- ❑ Walls, floors, and ceilings that are securely constructed and create their own three-dimensional security zone.
- **Use of impenetrable materials.** The materials and construction methods used for the envelope must be relatively impenetrable, even from sustained attack with tools. For example:
 - ❑ Floors: concrete with various finishes.
 - ❑ Walls: precast or cast-in-place concrete; concrete masonry units reinforced and grouted every 8 to 16 inches on center.
 - ❑ Ceilings: precast or cast-in-place concrete; steel security panels; cement plaster on expanded metal lath.
 - ❑ Roof: precast or cast-in-place concrete with built-up roofing membrane; heavy-gauge metal deck securely fixed in place with roofing membrane.
 - ❑ Windows: typically inoperable unless heavily screened with security-grade products; and constructed with the strongest security, detention grade glass products available and securely anchored.
- **Secured openings.** Other types of openings into the main security envelope (other than the access points) should be secured. For example:
 - ❑ Passthroughs for such things as packages, money, and mail.
 - ❑ Ductwork.
 - ❑ Electrical openings.
 - ❑ Roof fan openings.



Secured windows in an indoor recreation yard. Note that these windows open for air circulation but have security mesh to prevent penetration. (Photograph courtesy of Voorhis Robertson Justice Services.)

- ❑ Air supply grills.
- ❑ Skylights.

In general, these openings or penetrations in the walls, ceilings, and roof of the main security perimeter should not exceed 5 inches in one dimension unless the opening can be confined to an area of 8 x 8 inches or less. Openings exceeding these dimensional limits should be protected by steel bars or other security elements that effectively reduce the size of the opening.

- **Limited public view.** Public view of inmate living or activity areas must be limited as much as possible. Techniques to accomplish this and still provide natural light to inmate-occupied areas are discussed in chapter 3, “Site Selection and Design.”
- **Secured outdoor exercise areas.** Outdoor exercise areas traditionally present special problems for security envelope design, including at least five typical concerns:
 - ❑ Eliminating view conflicts and physical contact with the public.

- ❑ Controlling the introduction of contraband from outside sources.
- ❑ Preventing intrusion or escape through, under, or over the exercise area fence or wall.
- ❑ Providing a means of egress from the area if it is to serve as a containment area for facility evacuations.

Outdoor exercise areas represent a particularly vulnerable point in the main security envelope, and special care must be taken during the design effort to close potential holes. Related design considerations are addressed in chapter 19, “Exercise Areas.”

- **Use of CCTV.** CCTV monitoring systems can provide some control over the exterior of the main security perimeter. If CCTV is used, several considerations apply:
 - ❑ The number of cameras should be minimized to facilitate effective monitoring by master control.
 - ❑ Recesses and pockets in the exterior of the building should be minimized to reduce the number of cameras and monitors required and facilitate a better exterior view.
 - ❑ Cameras should be placed in locations inaccessible to public contact and potential tampering.
 - ❑ Cameras should be able to accommodate changes in light level (day-night), where applicable.
 - ❑ Cameras with swivel and zoom features are desirable, to allow master control to focus on specific areas on the perimeter.

If a CCTV system is used, monitoring of the rooftop should be considered, especially if the facility is a single-story structure. Building rooftops should be as clear of obstructions as

possible. Designs can discourage access to the roof via downspouts, light fixtures, and other elements that protrude from the exterior.

- **Use of perimeter lighting.** Perimeter lighting is a useful feature for discouraging approaches to the security envelope by the public or persons collaborating with inmates on escape attempts.
- **Secured access to mechanical rooms, buildings, or penthouses.** Access to these areas should be secured at both the outside and inside access points to the rest of the jail.
- **Security-sensitive landscaping.** Facility landscaping must be considered in light of overall security design. All shrubs and trees should be placed to ensure that sightlines to the perimeter are not obscured. They should not be positioned where they can be used by an intruder to scale perimeter walls and fences. Landscaping may be useful to help preclude approaches to the exterior (tough, thorny bushes, for example).
- **Climate-controlled heating, ventilating, and air-conditioning (HVAC) system.** Installation of a fully climate-controlled HVAC system should be considered to avoid the need for operable windows.
- **Limited access for inmate visitors.** The design should limit inmate visitors to a primary internal security zone created for visitation purposes adjacent to the public lobby (exhibit 8-5). Contact visits, if permitted, should occur in a designated area within this zone under staff supervision.

Special considerations for denying contraband

Most of the preceding design considerations that help deny escapes fundamentally help deny contraband passage from outside parties. However, contraband can be introduced into the facility

Section 2: Major Design Considerations

Exhibit 8-5. Visiting Area in Relationship to Main Security Perimeter

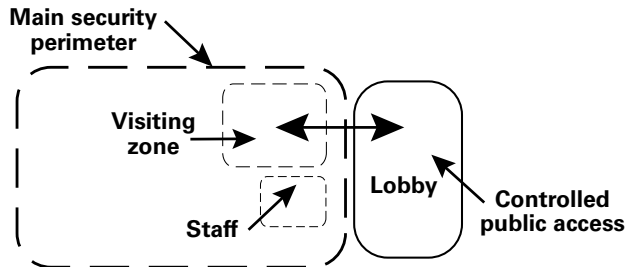

by inmates and others entering the main security envelope. Three types of inmates are usually involved:

- The escorted inmate who acquires contraband while outside the main security envelope (e.g., in court or at a medical appointment). Contraband enters the jail when officers returning the inmate fail to perform an adequate clothed or unclothed search prior to returning the inmate to his/her housing area.
- The work releasee, or inmate worker who has outside privileges and is not subject to search each time he/she reenters the main security perimeter of the facility. This is especially problematic if work release inmates do not have a separate entrance into the facility or are not housed separately from general population inmates.
- Inmates who come in contact with outside parties such as attorneys, counselors, or contract food service workers who either inadvertently or purposely pass contraband.

Design features that can be incorporated to reduce the risk of contraband passage include:

- **Separate entryways.** Separate entry and exit should be provided for work releasees and inmate workers, who both provide a natural

chain of contraband passage. If separate entryways are not achievable, staff will have to control opportunities for contact and passage of contraband.

- **Separate clothing exchange areas.** Separate areas should be provided in which inmate workers and work releasees can leave potentially contaminated clothing and personal items and dress in institutional clothing prior to returning to a secure housing area.
- **Separate housing areas.** The housing areas of work releasees should be clearly separated from those of inmate workers by locating the two in separate primary internal security zones and precluding one group from entering the zone of the other.
- **Separate laundry facilities for work releasees.** Work release inmates should have separate laundry facilities. Providing work releasees with separate facilities for exercise, visiting, and other activities might also be considered unless staff action can minimize contraband passage opportunities.
- **Vestibules.** Vestibules allow all escorted inmates, work releasees, and inmate workers to be searched at reentry. Where inmate workers are involved in receiving and storing food or packaging refuse, creating an enclosed delivery vestibule and refuse storage area is a good idea. Such an area would use a system of interlocking doors observed by CCTV from master control and/or directly by staff.
- **Separate work areas for inmate workers.** All activities and work functions of inmate workers (e.g., food preparation, laundry) should be located inside the main security envelope and outside of primary internal security zones provided for inmate housing.
- **Pedestrian entrance vestibules.** These vestibules should be designed to avoid hiding

places that could be used for concealment and later retrieval of contraband during entry and exit by inmates.

- **Exterior doors.** The doors used should seal tightly to prevent the introduction of contraband under the door or between the frame and the door.
- **Secure routes to court facilities.** Opportunities for public contact should be eliminated or minimized.
- **Secure space for interviewing.** Space for interviewing inmates should be provided within the main security envelope rather than outside the envelope in jail administration or law enforcement areas.
- **Search rooms.** Providing search rooms allows inmates to be checked as they depart from different areas of the facility to their housing unit after contact with others.
- **Metal detection.** Metal detection equipment should be located at key points of entry through which all visitors must pass under the supervision of an officer.

Perimeter Fences/Walls

The perimeter fencing most commonly found at jails built on large parcels of land in nonurban areas typically consists of two parallel fences around the entire institution. The only openings in the fences are at the public entry near the administration portion of the building and at a vehicle entry point. Some distance between the two fences is necessary to prevent jumping from the top of one fence over the other or using instruments (e.g., ropes, ladders) to bridge from one fence to the other. The space between the two fences also allows for the placement of security wire to inhibit movement if the first fence is penetrated or scaled.

For the jail that is a single discrete building, the need for such a perimeter fence or wall is less clear than for large facilities that have multiple buildings and high levels of required outdoor inmate movement. In the majority of jails, most or all inmate housing activities and movement occur within the secure envelope of the physical plant, negating the need to physically contain outdoor movement.

There are, however, reasons that a perimeter fence or wall around some or all of a jail makes sense:

- There may be concerns regarding the jail's immediate adjacency to sensitive public areas that justify additional separation or screening, such as schools, playgrounds, parks, nursing homes, or densely populated areas.
- The amount and type of inmate activity occurring outside the jail building, such as inmate gardening, groundskeeping, building maintenance, and field recreation, might require a fenced enclosure.

In most instances, a single fence rather than a double fence makes sense, especially if inmates do not have access to the outdoor areas or if only a few inmates use the areas and they are directly supervised by staff. If view conflicts are perceived or the appearance of a fence is objectionable, a perimeter wall would be more appropriate but probably more costly.

If a perimeter fence or wall is incorporated into the building plan, several design characteristics should be considered:

- A minimum height of approximately 12 feet.
- If a fence is used, a tightly woven mesh or wire to inhibit climbing.

Section 2: Major Design Considerations

- Security wire (e.g., razor wire) at the top of the fence or wall (in the case of a wall, the security wire might be just behind the wall out of public view for aesthetic purposes).
- An ability to observe all portions of the area defined by the fence, especially if inmates are to use the area (by a direct view from a constantly staffed post, by CCTV, or by both).
- An extension of the fence or wall below grade to preclude tunneling under it.
- Perimeter lighting to enhance nighttime surveillance and to discourage assaults from the outside during the night.

Internal Security Zones

Primary internal security zones incorporate the following key principles into facility design and operation:

- Ingress and egress are regulated and monitored by direct visual or CCTV observation from a master control center.
- All movement of people and materials from one zone to another is restricted and controlled by strategic placement of corridor gates or doors remotely operated by master control.
- All out-of-cell inmate activities in the zones are directly supervised, observed from a constantly staffed post, or monitored by CCTV.
- A secure three-dimensional envelope is created, similar in construction to that of the main security perimeter, although the zone can frequently share elements with the security envelope.

One key aspect of defining primary internal security zones is to achieve a proper balance between security needs and efficiency. It is possible to subdivide the jail into so many zones that movement of staff and inmates becomes difficult and



Jail with dual fenced perimeter with razor wire.
(Photograph courtesy of Jim Rowenhorst.)

burdensome. One consequence of doing so is that staff prop open doors that are meant to be closed and are indicated as closed on control panel annunciators. Thus, the value of sophisticated control technologies is contravened and concepts of zoning and movement control break down.

Secondary internal security zones incorporate the following key principles into facility design and operation:

- Ingress and egress are regulated and monitored by master control or another officer through locked doors that may be operated either remotely or manually.
- Inmate activities in the zones may be supervised or unsupervised, depending on the risk level of the inmates in the zones.
- Construction and material approaches for secondary, and even tertiary, internal security zones might be less secure than those for the main security envelope and primary internal security zones, although needs vary on a space-by-space basis.

For example, the security needs of a medication storage space or a disciplinary detention cell, both of which might be defined as tertiary security zones, may well demand construction similar to that of a primary zone. Conversely, the indoor exercise area, as a secondary internal security zone, would typically not require construction as heavy or as secure as a primary zone or the main security envelope unless a portion of it (wall, ceiling/roof) coincided with a higher level perimeter.

Readers are advised to examine the data on individual functional components presented in section 3 and assess the implications for security construction.

Conclusion

Accurately defining and creating security envelopes and zones is essential in an architecturally secure facility. Effective development of envelopes and zones is also one of the key space-organizing principles of a jail design. To be fully effective, however, the architectural concepts must complement and, in fact, derive from fully developed operational principles regarding inmate classification and separation, supervision and surveillance, staffing, and basic policies and procedures of operations. If a true marriage between security design and operations is achieved, the jail's basic mission of ensuring exterior and interior security will be achieved.

Chapter 9

A jail does not operate in a vacuum. It is only one part of a larger, interrelated criminal justice system. Officials from other elements of the system interact with jail inmates and staff on a daily basis, and jail designs need to enhance the effectiveness of these interactions. This section identifies ways in which other criminal justice system participants interface with the jail.

The system elements that have the most interaction with the jail include:

- Affiliated law enforcement agencies, most typically the sheriff's office and local police departments.
- Courts.
- Defense and prosecuting attorneys.
- Probation and parole.

A General Caution

Establishing proper interface between the jail and other elements of the criminal justice system entails more than just making sure inmates get to court or see an attorney. Sometimes design processes get so focused on solving jail facility problems that they inadvertently create problems for law enforcement, probation, court, and other related functions.

This problem is especially acute when the jail facility shares a site with other criminal justice functions. Specifically, jurisdictions have expanded jails in less-than-desirable ways on existing sites solely because the courts are also there. These solutions have often ignored the growth needs of the courthouse or its fundamental inadequacy as a modern, secure court facility.

Criminal Justice Interface

Then, when the jurisdiction later turns its attention to court needs, it discovers that the available space on the site is inadequate and that solutions require either a new facility or an additional facility at a different location. The jurisdiction is left with the worst of all worlds: higher costs for the court solution, no interconnection between the jail and courts, and a jail design that was compromised by erroneous site considerations.

To avoid this scenario, jurisdictions should consider taking the following steps during predesign planning for the jail:

- Develop a broad understanding of facility, parking, and operational needs of related criminal justice functions.
- If possible, develop a criminal justice facilities master plan so that the jail project fits into a clearly understood present and future context.
- Invite criminal justice officials to be routinely involved in jail planning meetings.
- Before using a shared site, develop sketch work that shows how the site will accommodate the jail design, jail expansion, expansion of the other facilities at the site, and all related parking needs.
- Evaluate jail options at varying distances from the site to test actual functional and cost differences—it may be that a new location would not be as detrimental as staying on the courthouse site.

Law Enforcement Interface

Most county jails are organizationally a part of the local sheriff's department. In practical terms, while larger facilities may be built in suburban or rural areas, some distance from the sheriff's

Section 2: Major Design Considerations

office, virtually all smaller jail facilities are constructed in combination with a sheriff's administrative, road patrol, civil, and dispatch functions. The close administrative and arrest-processing ties between law enforcement and jail operations frequently result in a blurring of distinctions between the two different functional needs. For example, in smaller jails, law enforcement communications/dispatch staff are often responsible for control and electronic monitoring of jail areas, and the kitchen in some jails is the break area for law enforcement staff.



Although some sharing of staff and space can be successfully planned and designed, experience has shown jail resources are frequently used to compensate for insufficient law enforcement provisions. The most frequent complaints relate to provisions for storage and/or staff support. Many jurisdictions find they need to reassign some jail space for law enforcement use to relieve critical deficiencies, creating a twofold problem:

- Space planned for jail use is lost, thereby recreating some of the same overcrowded or deficient jail conditions that originally prompted new construction.
- The reassigned spaces are not efficiently located, requiring law enforcement staff to regularly move in and out of the jail security envelope for nonjail purposes. This increases the workload for jail control staff and potentially generates security concerns. Secure jail operations require a specific security envelope that restricts and controls access of all nonjail persons and activities. This concept of control should include nonjail sheriff's department staff.

The principal reason space shortages exist in new law enforcement components seems to be that most of the focus was on the jail throughout the facility development process—a logical thing

when one considers the controversies that frequently propel jail projects. The solution? Treat both the jail and law enforcement functions more equally, beginning with a solid review of how they interrelate.

When the jail facility is jointly constructed with law enforcement spaces, a number of space-sharing concepts can be considered in both the jail and law enforcement areas. Space sharing can help eliminate duplication of resources while providing a comprehensive facility plan at minimal construction cost. These issues and their design implications are discussed next.

The success of the jail design can, to some extent, depend on the successful planning and design of adjacent nonjail areas. The following issues, while not dealing with law enforcement design per se, focus on the design of key law enforcement elements that interface with the jail: public/staff separation, law enforcement dispatch and jail control in small jails, records, arrest processing, investigations and lineups, jail administration and staff, food service, and deliveries.

Public/Staff Separation

The organization of jail building and site designs frequently focuses on separation of staff, law enforcement, and public access, including parking, staff entry, arrestee entry, visitor entry, service delivery access, and so forth. Law enforcement functions need to be similarly separated. Coordinating these separations during initial site utilization studies can create the basis for better separation of public from nonpublic areas and possibly yield a more efficient shared public lobby and unified staff parking area (exhibit 9-1).

Law Enforcement Dispatch and Jail Control in Small Jails

Jurisdictions with smaller sheriff's departments and jails may use staff in the dual role of jail master control



Exhibit 9-1. Separation of Public From Nonpublic Areas

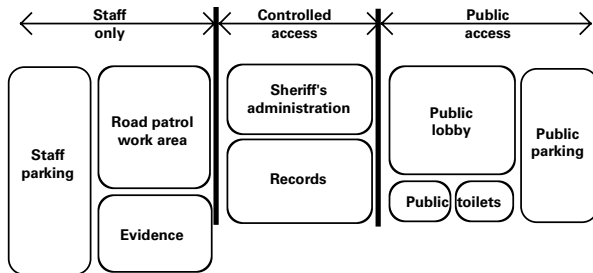

officer and law enforcement communications/dispatch officer. Whether this operational practice can, or should, continue is a critical decision in developing a small jail design. It is rarely an issue or option for medium- and large-scale facilities.

The expectations for staff monitoring of inmate activities in new jails and the sophisticated building and security electronics systems in these jails dramatically increase the tasks and responsibilities of jail staff when compared with systems in older jails. Where population growth is a factor, the increasing volume of communication calls alone may dictate separate dispatch staff. To assess the issues involving the master control jail position and communications dispatch, see chapter 13, “Master Control,” in section 3.

Care should be taken in the selection of staff used in this dual function to avoid the problems that can arise when staff trained as dispatchers are thrust into a jail control role they do not want and that they perform reluctantly and ineffectively. In designs where the master control/dispatch center is strategically located to visually monitor and control a series of jail spaces and activities around it, dispatch staff frequently cut off the views by placing blinds or curtains over the vision panels, which can create a dangerous situation. In these instances, the use of trained correctional officers in the dual role is essential.

When communications/dispatch operations are to be combined with the master control space, the space may need to be located adjacent to or closely connected to the records area and/or the public lobby (exhibit 9-2). Dispatchers in small agencies frequently need access to records information not available in electronic data systems. They also frequently respond directly to citizen requests for assistance, especially during evening and weekend hours.

Records

When law enforcement and the jail share the same building, records storage and retrieval functions must be organized to ensure that both entities can access files easily. The active, hardcopy files for inmates should be created and stored in the jail until an inmate is released or transferred. The physical transfer of those files to a central records area requires little more than the design of a staff access route between the jail and law enforcement records areas or the creation of another means, like a pneumatic tube system.

Exhibit 9-2. Location of Master Control and Communications/Dispatch Operations Relative to Jail and Law Enforcement Areas and Public Lobby

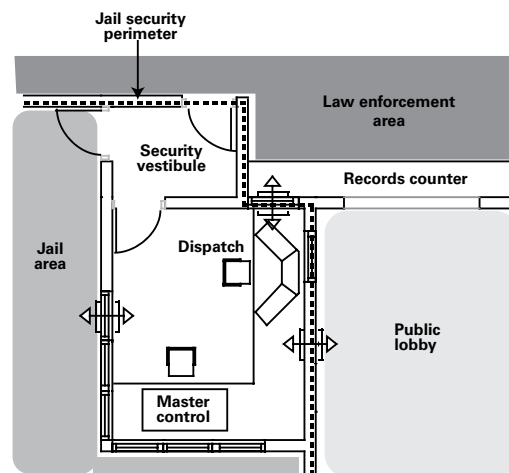

Arrest Processing

The chief interface between law enforcement and the jail is the transfer of custody of an arrestee from local police, state police, or sheriff's deputies to the jail staff. This is a daily occurrence that the jail design must easily accommodate.

An enclosed vehicle sallyport for entry of the arrestee and arresting officer is virtually standard in modern jails. Beyond that, provisions for the arresting officers should also include the following (exhibit 9-3):

- Weapons lockers in the vehicle sallyport.
- An exterior pedestrian entry through which an officer can reenter after moving his/her vehicle out of the sallyport or can park outside and walk the arrestee into the booking area.
- Visual monitoring by intake-release and/or master control staff of the entire arrestee route, in case the arresting officer needs assistance.
- A work area/security vestibule that provides a secure entry point through the jail's security envelope as well as a place for law enforcement officers to do pat searches, take property, and complete prebooking paperwork.
- Sobriety testing equipment in or adjacent to the work area/vestibule.

Exhibit 9-3. Provisions for Arresting Officers

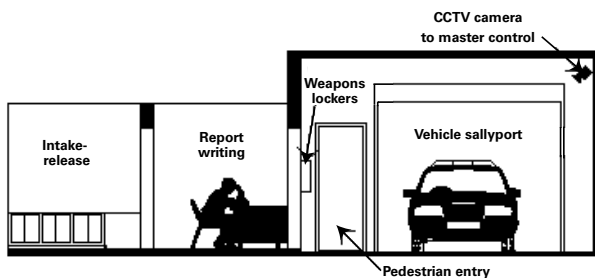

- Interview/interrogation space.
- A report-writing area, possibly with a telephone and computer access, for the arresting officer.

Other provisions for the arresting officer might include:

- Restroom facilities.
- Quick access to a temporary holding room for uncooperative arrestees or for processing multiple arrests.

These provisions should all be located adjacent to the intake-release area in a way that does not require the arresting officer to go beyond the entry vestibule and deeper into the jail security envelope. For more information on this topic, see chapter 14, "Intake-Release," in section 3.

Investigations and Lineups

Local and state law enforcement officers frequently need to interview jail inmates. To alleviate security concerns with inmate movement, interview space can be provided within or directly adjacent to the jail security envelope. If scheduling conflicts can be avoided, space used for law enforcement interviews can often be shared with the areas used for attorney visits and other professional visits.

Some departments indicate a periodic need for a lineup room for victim/witness identification of arrestees. This should be located so as to minimize public penetration of the jail and securely separate victim/witness movement from that of inmates. Given the limited use of lineup facilities, these spaces are prime candidates for multiple-use consideration. If located within the security envelope, the lineup room may also be used for inmate counseling, library, or religious services. If the space is located along the security envelope, extra care should be taken in selecting the

type of security glass used to separate inmates from the nonsecure side.

Jail Administration and Staff

Space for the jail administrator, clerical activities, conferences, staff training, and staff lockers and showers does not necessarily need to be within the jail security envelope. When law enforcement offices are built in conjunction with the jail, creation of one administrative and staff area can minimize expensive secure space and eliminate unnecessary duplication of spaces. Clerical, conference, and jail administration activities can take place in the same area. For example, with proper scheduling the same space can be used as a training classroom for both correctional officers and law enforcement officers. Jail and law enforcement staff locker areas can be combined outside the secure jail envelope with joint-use toilet and shower facilities. However, when these staff and administrative spaces are shared by both jail and law enforcement staff, care must be taken to ensure that there are adequate space and equal amenities (e.g., full-size lockers for all staff members) and that there will be no scheduling conflicts when using the space. For more information on these issues, see chapter 24, “Administration and Public Areas,” and chapter 25, “Staff Areas,” in section 3.

Food Service

The jail food service area is frequently used as a lunch and coffee-break space for law enforcement officers. This sharing of kitchen space has also emerged where space for disaster services/emergency operations are included in an overall facility plan. If the kitchen is located outside the security envelope, this sharing of space is problematic only to the extent that it tends to discourage the use of inmate workers in food preparation and cleanup. Securely moving three meals a day in and out of the security envelope can be an inefficient use of staff time.

It is usually better to dedicate kitchen facilities to jail meal preparation and to locate these spaces within the jail envelope to enhance security and to minimize staff time in serving meals and returning trays and utensils. Separate canteen or break area facilities for law enforcement staff outside of the jail security envelope result in minimal addition of space and equipment and a more efficient and secure operation overall.

Deliveries

In older facilities the secure vehicle sallyport used for delivering arrestees is often used for deliveries of supplies into the facility. Using the arrestee sallyport for other purposes can be dangerous because of the equipment left in the area, the potential to introduce contraband into the secure perimeter, and because it can block secure delivery of arrestees. The ideal solution is to provide a separate loading dock for the delivery of food and supplies. Additionally, the vehicle sallyport should not be used for other functions not related to the processing of arrestees, such as vehicle maintenance or equipment or supply storage.

Courts Interface

Although the jail’s interface with the courts varies by jurisdiction and state law, many of the arrestees booked into the typical jail will make one or more court appearances before they are released from custody. If inmates are remanded into custody or cannot make bail, they are often taken to court many times during their incarceration for their trial and other court proceedings. Inmate movement to and from court tends to occur in three ways:

- The inmate is walked through secure and/or nonsecure corridors directly to the courtroom.
- The inmate is either driven or walked to a courtroom at a separate location.

Section 2: Major Design Considerations

- The inmate appears in court facilities specially set up at the jail.

Corridor Movements

When the jail and the courthouse are directly connected, the following considerations should be taken into account during the planning process:

- Movement through the jail security envelope should be through an interlocked security vestibule.
- Once out of the security envelope, as much movement as possible should be through corridors, stairs, and elevators to which the public has no access or where public access can be temporarily precluded. Moving inmates through the public corridors of the courthouse is highly undesirable.
- Movement should also be monitored by jail staff other than the escort officer, such as the master control officer.

Movement to Offsite Court

Increasingly, new jails are being built on sites other than the courthouse site. When the jail is on a separate site, court attendance requires movement of inmates outdoors, thus introducing increased risks of escape and assault. Even if the jail is only one block from the courthouse, it is strongly recommended that an inmate not be walked to the courthouse, but driven there in a secure vehicle. When planning for the movement of inmates to court, other related considerations include the following:

- Departure from the jail should be through the vehicle sallyport.
- Access to the sallyport should, if possible, be via a secure route that does not go through the intake/booking area.
- Necessary restraint equipment should be readily accessible near the vehicle sallyport.

- A place to hold or stage the inmates to be transported should be available.
- The courthouse should have its own vehicle sallyport to avoid the need for any inmate exposure to the public.

Appearances at the Jail

Some jurisdictions with separate jail and court facilities conduct early, uncomplicated court appearances at the jail. Such appearances include arraignments (also called first appearances) and, in some states, probable cause hearings that are required before arrestees can be booked. Even preliminary hearings are conducted at some jails.

These early proceedings can be done at the jail because they are brief (3–5 minutes for arraignments) and do not involve many people. A very high percentage of inmates are released on bail, recognizance, or a third-party signature immediately or shortly after their first court appearance.

Court appearances at the jail generally take place in two ways:

- All participants are brought to a specially built court space or an easily adaptable multipurpose space at the jail.
- A video appearance system allows everyone but the inmate, and perhaps a public observer, to participate from the courthouse.

Courtrooms at the jail

Building a courtroom or multiple courtrooms into a jail is an option that is not taken very often, especially in smaller jails. It is frequently perceived as inconvenient to judges and court officials, it adds to construction costs, and it broadens security responsibilities at the jail. When this concept is pursued, several questions must be answered:

- Do jail staff have security responsibilities in the courtroom, or do the court and its bailiffs?

- Will all noninmate participants be screened through jail facility security, including metal detectors?
- Will defendants who are not in custody also make their first appearance at the jail courtroom?
- How extensive will the court operation be? Must there be space for a judge's office, a clerk's office, attorney-client consultation, public waiting?
- In smaller jails, can the court space be used by the jail for program activities in the evening and on weekends?

Following are some design considerations that apply if a courtroom is designed into a jail facility:

- Separate interlocked security vestibules for access to the courtroom by (1) inmates and (2) the public and officials.
- Closed-circuit television (CCTV) monitoring and intercom communications to the master control center.
- A primary security zone for the court area (e.g., window openings constructed of detention-grade materials).

Video appearances at the jail

Using video technologies has become the common way to hold initial court appearances at many jails, especially when the jail is remote from the courthouse. With video, the only participants at the jail are typically the inmate and jail security staff. In some states, public observers may have the right to directly witness the inmate's court appearance at the jail. Judges, prosecuting attorneys, court reporters, clerks, bailiffs, and defense attorneys stay at the courthouse. So do most, if not all, of the public and all out-of-custody defendants.

Space requirements for video appearances are minimal and can easily be provided at most jails in a multipurpose room. Equipment needs are generally limited to a television (TV) monitor, a camera, a microphone, switching equipment, chairs, and a table or podium. Video signals are transmitted via microwave, cable TV lines, or by dedicated wiring if the courtroom is close enough. Monitors generally provide "split-screen" views so that all major participants can be seen at one time.

In developing a video appearance capability at the jail, several design issues should be addressed:

- Provision of backup observation of the space by CCTV or, preferably, direct line of sight from a staff post.
- Protection of video appearance equipment from tampering or accidental damage if the space is shared by other functions (e.g., through means such as closeable cabinets, roll-away carts, or closeable alcoves).
- Configuration of the space so that multiple inmates can simultaneously hear the initial instructions from the judge.
- Provision of a fax machine or some other means by which papers can be moved quickly between locations.
- Provision of sufficient distance between camera and defendant to accommodate full-body views if desired by the judge.

Attorneys

Inmates need access to attorneys, particularly defense attorneys. This is accomplished primarily through telephone conversations and personal meetings or interviews.

Section 2: Major Design Considerations

Telephones in the dayrooms of housing units facilitate inmate/attorney consultation but have the disadvantage of offering limited privacy. A more private telephone alcove or a prefabricated, acoustically screened station may be a good solution.

Attorney/client interview space can be either contact or noncontact, or both, depending on the standards of individual states. Discussion with the local bar association is advised to determine the best solution in terms of appropriate access and security.

Attorney access to contact interview spaces should always be gained by passing through metal detectors and an interlocked security vestibule. Jurisdictions considering the use of noncontact visiting space should remember that attorneys sometimes must pass paperwork to the inmate for review or signature. Without a secure paper pass, jail officers will bear the burden of passing paperwork back and forth.

When planning for attorney and other professional visiting areas, the jurisdiction should consider the following issues:

- Good acoustic quality.
- Ample desk surface for files and paperwork.
- Adequate artificial lighting on the desk surface.
- Seating for at least two attorneys.
- Accessible space compliant with the provisions of the Americans with Disabilities Act (ADA) for attorneys or inmates who are wheelchair-bound or have other disabilities such as hearing or sight issues.
- A means of communication that allows attorneys to talk to staff (e.g., to announce the end of a visit).

- A panic alarm, in case of an emergency, especially if the space is not directly observed by a staff member.
- Locating the space so that random or constant staff observation is possible.

Public Defenders

The needs of public defenders are somewhat different from those of private attorneys. It is not unusual, for example, for the public defender to see several inmates during one trip to the jail or, in smaller jails, to represent most of the jail's population. For efficiency's sake, it is helpful to design an inmate waiting area adjacent to the attorney-client visiting rooms (exhibit 9-4). Since such a space could hold a mix of inmate classifications, it should be in direct view of a constant-staffed post, if possible.

Another way to make the public defender's work more efficient would be to provide a small office with access to a telephone, computer, and fax machine. The computer should be linked to any court or relevant, nonprivate inmate data systems available.

Probation/Parole

Probation and parole staff have interview needs similar to those of attorneys, and the space

Exhibit 9-4. Inmate Waiting Area Adjacent to Attorney-Client Visiting Rooms

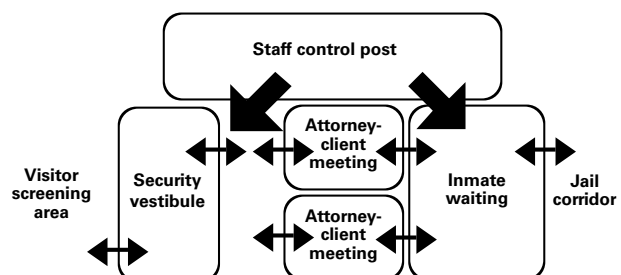

provided for attorney/inmate interviews is normally sufficient for their needs. The planner must ensure, however, that enough space is available to meet the needs of all who will share the space.

The most distinctive need of probation/parole officers is for hearing space. Probation/parole hearings occur when offenders are arrested for alleged violation of probation or parole conditions. Many jurisdictions accommodate hearings at the jail to minimize inmate movement outside the facility. Hearing rooms should accommodate four to eight people, provide a large table and chairs, have good acoustics, and provide convenient electrical outlets for recording and transcription equipment.

Conclusion

There are important points of interface between the jail and other components of the criminal justice system. Although the collective space needs or space organization demands of these other functions are not great, they have significant impact on the successful operation of the jail. These interface issues deserve serious consideration during predesign planning and skillful development during design.

Functional Components and Relationships

A jail is a single building made up of many small pieces, or components, that represent different functions or activities. Together, the components are intended to satisfy all of the needs of inmates, staff, and public users of the jail.

The selection of appropriate components, the details of their development, and their arrangement in relation to each other on a selected site are what make each jail design unique and responsive to local conditions. It is this uniqueness of need and condition that makes it difficult to apply one standard, “cookie-cutter” design to all jail design problems. Developing a working knowledge of the various components needed by the jurisdiction in terms of their function, interrelationship, and impact on design is critical to meeting local jail needs effectively.

In response to the need for information on jail components, the purpose of this chapter is twofold:

- To identify the major and typical components of a jail.
- To describe how these components typically interrelate.

Detailed functional and design information about individual components is presented in section 3, along with elaboration on many of the issues raised in this section.

An additional purpose of this chapter is to review how certain types of functions might occur in the same room or area, that is, to identify jail functions that can share space. This is an important concept for smaller jails in particular, because the infrequency of certain activities sometimes makes sharing space essential to the efficient use of scarce local resources.

Jail Components

If a person documented every possible activity that could occur in a jail, the resulting list would be quite lengthy. Fortunately, not all of these activities have space implications. Many are comfortably managed within major activity categories for which proper space is designed and allocated, and some have no direct space impact at all (e.g., key control and inspections). Following are the major activity categories, or **functional components**, for which dedicated space is needed:

- **Master control:** Monitors and controls all building communications, safety and security systems, entrance and egress routes, and movement within the facility and often coordinates management of emergencies in the early stages.
- **Intake-release** (also referred to as “booking,” “reception,” and “admissions”): Receives and processes incoming arrestees or inmates and releases outgoing inmates.
- **Housing—general:** Accommodates the individual security, sleeping, hygiene, privacy, and routine personal needs of the main, or general, inmate population of adult men and women.
- **Housing—special:** Accommodates the individual security, sleeping, hygiene, privacy, and unique care needs of special inmate groups (e.g., those in disciplinary detention or protective custody; those who have disabilities or who are mentally ill, suicidal, intoxicated, or medically infirm; juveniles remanded as adults) and of inmates who regularly leave and return to the jail on a regular basis (work release or periodic confinement).
- **Health care:** Accommodates the health care needs of inmates, including medical and

Section 2: Major Design Considerations

dental exams, tests, distribution of medications, sick call, medical records, and storage.

- **Visiting:** Accommodates individual and group contact between inmates and family or official visitors (staff, counselors, attorneys, etc.).
- **Indoor and/or outdoor exercise:** Accommodates the physical exercise needs of inmates in an indoor or outdoor setting and storage of necessary support equipment.
- **Programs/services:** Accommodates inmate needs in areas such as recreation, education, counseling, training, library services, and religious services.
- **Commissary:** Accommodates basic inmate needs or wants for miscellaneous items such as pens, paper, toiletries, and snacks.
- **Food service:** Accommodates the receipt and storage of food and food supplies; the preparation, delivery, and consumption of meals; cleanup after food preparation and meals; and removal of refuse.
- **Laundry:** Receives, cleans, mends, stores, and distributes all reusable personal items used in the facility, such as clothing, linens, bedding, pillows, and mattresses.
- **Administration/public area:** Organizes and manages the daily business of the facility, accommodates public access to the facility, and responds to the public's need for information and services.
- **Staff:** Accommodates the training, hygiene, fitness, and personal needs of facility staff.
- **Storage:** Accommodates the need to maintain various types of supplies, equipment, and spare parts safely and securely.
- **Maintenance:** Initiates preventive maintenance, fixes and replaces worn or damaged

equipment and materials, and cleans and maintains existing facilities.

- **Mechanical services:** Provides heat, ventilation, and air conditioning; water and waste lines; and main and emergency power supplies.

Degrees of Development

The typical jail has each of the preceding functional components. However, there are significant variations from facility to facility in the degree to which some of these functions are provided, largely because of operational and economic considerations. In some facilities, the functions are minimally developed. As a result, the function has a limited impact on space and equipment requirements. In other facilities, the same components are fully developed and require a complete range of space and equipment.

Local officials, planners, and architects must determine needs with respect to each functional component during predesign planning to design and arrange spaces properly.

Some of the functional components that vary greatly in their degree of development in jails are discussed below. These components reveal significant opportunities for space savings and measurably affect the way in which a facility operates on a daily basis. They are discussed further in section 3. In larger jails there is generally less flexibility in the development of these spaces.

Food Service

Larger jails will need adequate space and equipment for food service. An industrial food service operation will require space for cooking equipment (e.g., grills, steam kettles); refrigeration units; freezers; dry food storage; food preparation areas; a meal distribution system; a cleanup area,

to include commercial dishwashing equipment; storage for trays, cups, and utensils; and a food cart sanitation area. Developing space requirements for a food preparation and distribution area is complex and will generally require input from a food service expert.

Due to the expense involved in building and running a food service operation in the jail, some smaller jails have found contracting with local restaurants, hospitals, or schools to cater food to be more economical than preparing their own meals (exhibit 10-1). This approach can significantly reduce space and equipment needs for food service preparation, storage, and cleanup. Other facilities choose to serve a cold breakfast and cater the remaining meals, reducing space needs compared with a full-service kitchen operation.



However, with the elimination or limitation of food service space and equipment, new operational and design concerns arise:

- Ensuring secure delivery of meals each day, including dealing with nonjail personnel in the delivery process.
- Maintaining the temperature and quality of food, which may require equipment and space for reheating or cooling meal items at the jail.
- Distributing the food and, perhaps, providing space for food distribution equipment, storage, and cleanup.

Exhibit 10-1. Catered Food Service

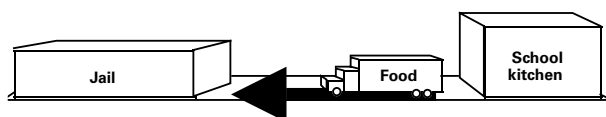

- Identifying the source of trays, cups, and utensils and, if the jail is the source, how and where they are accounted for, cleaned, and stored.
- Allowing for the possibility of losing catering services.
- Planning for increases in the inmate population to a point where it is no longer cost effective to have meals catered.

Laundry Service

Most jails design new facilities with areas for laundry and storing of clothing and linens used in the facility. These laundry areas usually contain industrial washers and dryers; space for sorting and folding clothing and other items; storage areas to hold supplemental clothing, linens, pillows, and mattresses; and areas for laundry collection and distribution carts. It is a common practice to have work release inmates do their own laundry at the jail, and washers and dryers are often installed in the work release housing area.

However, some jails have found it economical to use outside laundry services, thus reducing facility space and equipment needs. Others send some laundry out (sheets, blankets, jail clothing) and wash personal underwear, socks, and nonjail clothing in house.

Even if laundry services are provided by outside sources, several operational and design issues remain:

- Ensuring of secure delivery of laundered goods by nonjail personnel.
- Storing and sorting of laundered goods, including personal clothing, before distribution.
- Storing goods that are not immediately distributed.

Section 2: Major Design Considerations

- Storing carts or other devices used in the pick-up and distribution of laundered goods (usually a twice weekly clothing/linen exchange).
- Laundering at the facility selected items (such as clothing soiled during arrest) required before the next cleaning cycle because of imminent court appearance or release.
- Cleaning of nonlaunderable items such as mattresses.
- Allowing for the loss of contractual services.

Component Relationships

Although each functional component plays a role in the facility and is generally expressed as a distinct, consolidated group of subsidiary spaces, no component operates in a vacuum. The components serve the same body of users and are therefore interrelated to some degree. This interrelationship may require that certain components be next to each other, that some merely be close to each other, or that some be separated from each other. It may require the ability to see, hear, or communicate with another space. Understanding these interrelationships is critical to organizing a jail design efficiently and effectively.

Exhibits 10-2 and 10-3 identify the typical interrelationships between all of the functional components that might be assembled in a jail. These relationships will probably prove satisfactory for most jails, but it must be stressed that **each jurisdiction must set its own criteria for these relationships** and that there is plenty of room for variation, no matter how minor. More detailed information on functional components is given in section 3.

Relationship Matrix

One way to express component relationships is through a matrix. This technique uses symbols

or, as in exhibit 10-2, numbers to indicate the nature of a relationship. By reading along the boxes leading from two different components to where they converge, one can find the number describing the relationship between the two spaces. A matrix is an effective form of documentation, in that it is very complete and can be as precise as desired. The weakness of a matrix seems to be that many people find the format difficult to follow.

Relationship Diagram

To some, a more effective way to communicate relationships is through use of a relationship diagram (exhibit 10-3). This is normally a drawing that consists of simple shapes arranged to reflect the relationship of one component to another. That is, if two components need to be adjacent, they are drawn adjacent to each other. If they need to be nearby, they are drawn nearby and linked by a line or graphic connector of some sort.

The component shapes in a relationship diagram are frequently drawn loosely enough that they are commonly referred to as “bubbles.” Hence the phrase, “bubble diagram.”

Relationship diagrams are used more frequently than matrixes because they can communicate a greater variety of information, such as view connections and external relations or public view conflicts and delivery service access.

Critical Relationships

A series of relationships and nonrelationships seems to be especially critical in a jail. Some of these involve subcomponents of the jail and deserve special attention: work release and other inmate areas; female housing and male housing; control positions and inmate-occupied areas; arrestee access, intake-release, and control; public lobby, visiting, and inmate areas; and maintenance support spaces and inmate housing areas.

Exhibit 10-3. Relationship Diagram

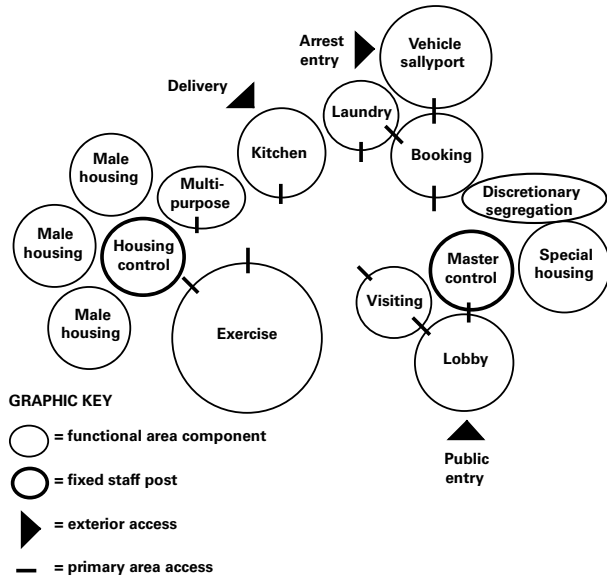

Work release and other inmate areas

Since work release inmates come and go from the jail on a daily basis, there is a high potential for contraband passage between them and the rest of the inmate population. Consequently, work releasees must be kept distinctly separate from the rest of the inmate-occupied areas of the jail. Each area shared with non-work-release inmates provides the opportunity for hiding of contraband by work releasees for later retrieval by non-work-release inmates. Contraband may also be passed to inmate workers during delivery of meals to the work release area or be hidden on meal trays and carts to be taken to other inmates in the jail population. To be effective, separation of work releasees should include separate entrances, laundry facilities, and exercise areas. In larger jails, inmates sentenced to work release are often housed in separate buildings. Their area, as noted in exhibit 10-4, is actually outside the secure perimeter of the jail.

Female housing and male housing

Female housing areas should be physically, visually, and acoustically separate from male housing areas. This requires careful design when the areas are nearby or placed in completely different locations within the building.

Control positions and inmate-occupied areas

To assure the safety and security of inmates and staff and to reduce vandalism to the facility in remote surveillance facilities, staff posts—potentially including master control—should be located with a direct view of inmate-occupied areas (housing, visiting, booking, exercise, and so forth). Constant direct view allows for better control of inmate behavior and reduces incidents that typically occur with intermittent observation, such as vandalism, assaults, and graffiti

Arrestee access, intake-release, and control

This set of relationships is critical because of the volume of incoming traffic at booking, the tension and risks involved in the booking process, the presence of officers from other jurisdictions, and traffic associated with the release process. If space allows it is ideal to separate the booking and release functions so that arrestees



Exhibit 10-4. Relationship of Work Release Area to Other Inmate Areas

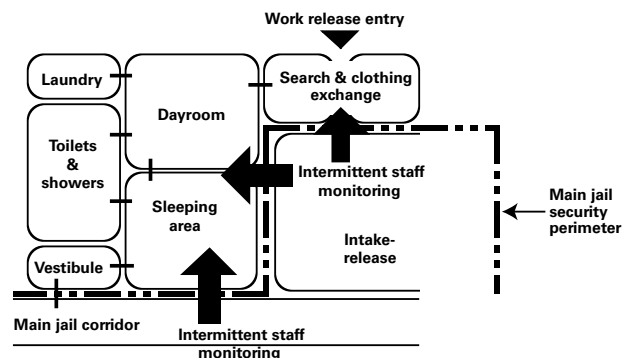

are released from a different door than they enter. Often, in smaller jails master control will be situated in a place where they can observe the area and quickly summon assistance in case of trouble, thereby providing backup for the booking officer.

Public lobby, visiting, and inmate areas

Control of public access to the secure areas of the facility is important in any jail. Because visiting is by far the most common reason for the public to enter the jail, visiting areas should be located adjacent to the lobby in a way that allows visitors to enter a controlled area but never to penetrate the inmate-occupied zones of the facility, including corridors. (See chapter 8, “Security Perimeter.”) If a courtroom is to be associated with the jail, it too should be located adjacent to the public lobby.

Maintenance support spaces and inmate housing areas

To facilitate daily cleaning, maintenance support spaces, such as janitor closets, need to be located inside or in close proximity to each inmate housing area. Staff must be able to provide inmates cleaning supplies and equipment quickly and efficiently so that inmates can clean their cells and dayroom spaces.

Space-Sharing Possibilities

Some functions occur infrequently and could well take place in the same space at different times, especially in smaller facilities. This flexibility, if accommodated by proper design, can save money in facility construction.

Space-sharing possibilities should be examined during predesign planning and should be judged on the basis of solid functional programming information, namely, function, activity type, scheduling, security, and numbers and types of

users. If space sharing still seems a possibility after such an evaluation, the varying architectural requirements should be examined to assure construction compatibility. Some of the functions in which space-sharing possibilities can be found are special housing, indoor programs and services, general housing in the smaller jail, contact visiting/counseling, and indoor/outdoor recreation.

Special Housing

Compatibility concept: A common space or spaces could be used interchangeably for short-term holding of intoxicated individuals, individuals with mental illness, or temporarily out-of-control inmates. Given that smaller jails, in particular, often will not receive mentally ill and out-of-control inmates at the same time, and that intoxicated people tend to be received at specific times during the week, it would seem wasteful to create a bank of cells for each of these categories.

Architectural compatibility issues:

- Spartan space with minimum equipment and protrusions.
- Benches low to the floor (8 inches).
- Security toilet/sink fixture.
- Floor drain (possibly flushing).
- High ceilings.
- Location observable from a staff post or frequently passed by staff.
- Space that accommodates personnel and/or crisis intervention workers.
- Sound control.
- Special ventilation.
- Washable surfaces.
- Variable lighting.

Section 2: Major Design Considerations

- Temporary housing only.
- No particular requirement for natural light.
- Protection of the inmate from self-injury by incorporating rounded edges, padding (if feasible by code, fire safety, and durability considerations), protective clothing for the inmate, and so forth.

Indoor Programs and Services

Compatibility concept: A variety of programs and services for inmates occur on a regular basis in most jails. Planning might determine that most, if not all programs and services can occur in one or more multipurpose spaces, depending on scheduling, the nature of the services, and the number and type of users: Smaller program rooms can be located in the housing area to cut down on inmate movement and can be used for a variety of activities, such as meetings or counseling sessions, barbering, classification interviews, and so forth. Larger multipurpose rooms outside the housing area can be used for educational classes, meetings, and religious services.

Architectural compatibility issues:

- Acoustical compatibility of various activities with adjoining areas.
- Size adequate to accommodate the most space-consuming activity planned for the area.
- Flexibility in furnishings and equipment.
- Storage for alternative furnishings and equipment.
- Temperature and light control.
- Finishes compatible with each function.
- Ability to clearly observe the space(s).
- Lack of security conflicts.

General Housing in the Smaller Jail

Compatibility concept: Given that the nature of the population in a smaller jail can change rapidly, it makes sense to create at least one small housing area that can accommodate a variety of inmate types. Specifically, one or more areas could be designed in such a way as to accommodate either high- or low-security men or women. Such a housing area is sometimes referred to as a “flex” or “swing area.”



Architectural compatibility issues:

- Small capacity unit(s).
- Ability to clearly observe the space from a fixed post.
- Appropriately separated from other housing units.
- Higher security detailing for flexibility (low-security inmates held in the area could be provided less-restrictive custody through management options).

Contact Visiting/Counseling

Compatibility concept: Attorney contact visiting, family contact visiting, and counseling all share a need for privacy, small groups, and interaction with the public. During the predesign programming phase, each jurisdiction will make decisions on how it will accommodate contact visits, who will be allowed to have contact visits, when contact visits will occur, and how they will be monitored. Even agencies that minimize contact visiting must, at the least, provide space for attorneys, clergy members, and representatives from other government agencies (e.g., social services, law enforcement, probation, parole, or Immigration and Customs Enforcement. Larger facilities often have several meeting rooms within a larger space designated for contact visits and staff dedicated to monitoring the contact visiting area. The

frequency of these activities in smaller jails suggests that one common space or set of spaces can be used, rather than providing separate physical accommodations for each activity. Attorneys and other potential contact visitors should be consulted during programming to identify their space needs.

Architectural compatibility issues:

- Private space.
- Small-scale space.
- Location in zone between public areas and main inmate-occupied areas.
- Ability to clearly observe the space.

Indoor/Outdoor Recreation

Compatibility concept: Both indoor and outdoor recreation spaces accommodate the same activities, such as basketball, handball, and weight lifting. The only difference is outdoor recreation is open to the outside—natural light and fresh air. By creating the ability to close open air access to the outside, a recreation area can be used as both indoor and outdoor space (exhibit 10-5).

Architectural compatibility issues:

- Adequate size to accommodate basketball and exercise equipment.
- Storage for recreational and exercise equipment.
- Heating, cooling, and lighting when used as indoor exercise space.
- High ceiling to allow for basketball.
- Ability to clearly observe the space.
- Located in close proximity to inmate housing.
- Sight and sound separation from housing areas to allow use by both males and females at different times.

Exhibit 10-5. Recreation Area That Can Be Used for Both Indoor and Outdoor Space

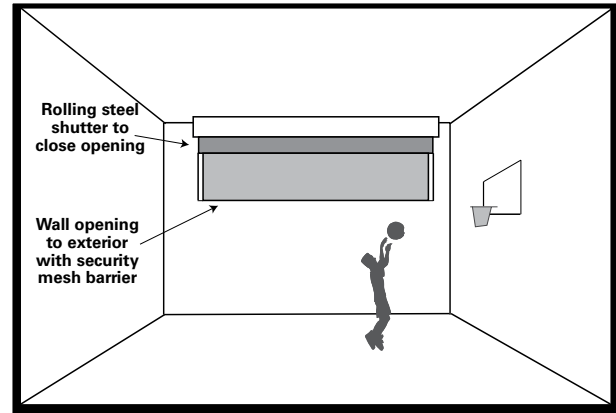

Space-Sharing Problem

A space-sharing problem occurs where a space used by inmates is also used by the public at other times. For example, public access to a multipurpose space that inmates would also use later for another program creates the potential for a major contraband passage problem. The visitor could bring nonmetallic contraband into the facility, undetected by the normal metal detector, and hide it for an inmate to retrieve later during a program in the multipurpose area. This problem could be solved by operational procedure (i.e., a thorough area search after use by the public) or by preventing space sharing by the two functions. This type of potential problem should be considered along with other space-sharing opportunities as each functional component of the jail is developed.

Conclusion

The space-sharing possibilities and issues discussed in this chapter merit consideration. However, it is important to reiterate that shared space should be carefully determined only after predesign planning verifies that function, security concerns, scheduling needs, and user types make it feasible.

Planning and Designing to Standards

Designing a jail involves the application of codes and standards developed by various local, state, and/or national agencies. Adherence to legally mandated codes and standards requires interaction with officials who represent the agencies that have established the codes/standards to obtain the approvals necessary to initiate construction. Awareness of and adherence to applicable codes and standards early in the planning and design process is necessary for a successful project.

Some people may view codes and standards as an intrusion into their jail design process and plans. However, building codes and standards exist to preserve the health, safety, and welfare of building occupants. Codes tend to be ideologically neutral; virtually all of their content is based on unsatisfactory and sometimes tragic experiences. Standards generally represent the collected wisdom of specialists and practitioners in a particular field.

If approached positively and early in the process, codes and standards can be useful tools in establishing safe and proven design parameters. Personnel from agencies that develop codes and standards can provide significant assistance to local officials and designers based on their experience with similar projects in the area and throughout the state. Both legally binding and advisory standards are worth reviewing before design, and even before programming, begins.

This chapter identifies standards and legal requirements that are referred to throughout the *Jail Design Guide*, as well as those that are particularly relevant to communities involved in the jail design process.

State Standards

In many states, one or more state government agencies have legislative authority to promulgate and enforce minimum jail standards. These agencies vary greatly in terms of the resources, approaches, and legal authorities they employ. In some states, design and operational standards for jails are extremely detailed and are strictly enforced; the responsible authority has the means to enforce standards up to the point of bringing suit against local governments whose facilities are noncompliant or by closing noncompliant facilities. In other states, the responsible agency may have detailed standards but lack the authority to enforce them and may therefore be limited to simply encouraging compliance through educational strategies such as training and technical assistance.

In some states, more than one agency has authority over jail planning, design, and operation. Often one agency focuses on the planning, design, and construction requirements while another agency is primarily charged with establishing operational requirements that deal with nonarchitectural aspects such as training standards, policies and procedures, and inmate services. Identification and review of state standards along with an understanding of their official role in the development of a proposed jail project are essential.

American Correctional Association and the Commission on Accreditation for Corrections

Persons both within and outside the corrections field may refer to the standards published by the American Correctional Association (ACA) and

Section 2: Major Design Considerations

the Commission on Accreditation for Corrections (CAC) as mandated “national standards” or “federal standards.” However, neither ACA nor CAC have the authority to mandate or enforce compliance with their published standards.

ACA and CAC are private, nonprofit organizations that administer the only national accreditation program for all components of adult and juvenile corrections. Their purpose is to promote improvement in the management of correctional agencies and in the design of correctional facilities through the development and revision of useful standards. This effort is supported by the corrections profession. Contributions from practitioners throughout the nation have enhanced these standards. Agencies that voluntarily decide to participate in CAC’s formal accreditation program are required to comply with certain eligibility criteria and enter into an accreditation contract.

In some states, the state standards affecting jails are outdated and are limited in their scope and applicability to modern jails. Seventeen states have no formal jail standards, and in some states with jail standards, no specific agency is charged with the enforcement of those jail statutes or standards. Therefore, little guidance is available to local officials and jail staff who are responsible for the funding and operation of local jails. In such cases, the ACA/CAC standards for adult local detention facilities represent a logical set of physical plant and operational criteria on which to base the planning, design, and operation of a new jail.

ACA/CAC standards pertaining to city and county jails or local adult detention facilities at the time

of this writing are published as the *Performance-Based Standards for Adult Local Detention Facilities, Fourth Edition*. A supplement is published periodically to document additions, revisions, deletions, and/or interpretations for all ACA/CAC standards manuals.¹ Those who use the ACA/CAC standards must review both the prevailing base standards document in its current edition as well as the most recent supplement.

ACA has recently released a new set of standards for local adult detention facilities, *Core Jail Standards*.² In these new standards, the minimum requirements have been carved out of the broader professional standards, leaving only those requirements that apply to every jail, and which could pose serious liability if compliance was not maintained.

Whether or not a local community formally participates in the ACA/CAC accreditation program, which requires entry into a contract and payment of an accreditation fee, a jail can use the *Performance-Based Standards for Adult Local Detention Facilities* or the *Core Jail Standards* to evaluate its operations and facilities. As stated in the “Introduction to Accreditation” section of *Performance-Based Standards*, “The recognized benefits of such a process may include improved management; increased accountability and enhanced public credibility for administrative and line staff; safer and more humane environment for personnel and inmates; and the establishment of measurable criteria for upgrading programs, personnel, and the physical plant on a continuing basis.”³

¹ In addition to standards for detention facilities, ACA/CAC publishes standards for most other areas of adult and juvenile corrections, including prisons, probation and parole, and community residential facilities.

² American Correctional Association, *Core Jail Standards* (Alexandria, VA: American Correctional Association, 2010).

³ American Correctional Association, *Performance-Based Standards for Adult Local Detention Facilities, Fourth Edition* (Alexandria, VA: American Correctional Association, 2004), p. xvi.

National Fire Protection Association *Life Safety Code*[®]

Established in 1896, the National Fire Protection Association (NFPA) is the leading nonprofit organization dedicated to protecting lives and property from the hazards of fire. NFPA publishes hundreds of nationally recognized codes and standards, including the *National Electrical Code* and the *Fire Protection Handbook*, as well as numerous fire-service training and fire-safety education materials.

The NFPA *Life Safety Code*^{®4} is the most authoritative and widely used resource available to planners, architects, engineers, building and fire officials, safety personnel, and manufacturers whose responsibilities include fire and life safety. The *Code* has many provisions that are mandatory for all types of occupancies. The term “occupancies” refers to buildings of different types and varying uses. The chapters “New Detention and Correctional Occupancies” and “Existing Detention and Correctional Occupancies” are especially useful to those who are designing a new jail.

NFPA also publishes the *Life Safety Code*^{® Handbook}, which includes clarifying commentary and illustrations to help users understand and apply *Code* requirements.⁵ The *Handbook* also explains changes to the *Code* since the previous edition was published.

Although NFPA publications and training seminars are excellent resources, NFPA does not have the authority to enforce compliance with the *Code* or other recommendations. However, many state and local building regulatory agencies have adopted the *Code* in whole or in substantial part, thereby giving its life safety requirements the force of law in jurisdictions under their purview.

It is important to consult applicable federal, state, and local laws and regulatory agencies that are relevant to the planning and design of jails. NFPA clearly states that it does not endorse compliance with its *Life Safety Code*[®] in cases where *Code* requirements are in conflict with other laws with which a local project must achieve mandatory compliance.

Americans with Disabilities Act

Passed by Congress in 1990, the Americans with Disabilities Act (ADA) seeks to protect individuals with physical and mental disabilities from discriminatory practices in employment, public services, transportation, public accommodations,



Fire exit blocked with stored items in violation of fire codes.
(Photograph courtesy of Jim Rowenhorst.)

⁴ National Fire Protection Association, *NFPA 101®: Life Safety Code*[®] (Quincy, MA: National Fire Protection Association, 2009).

⁵ Ron Coté and Gregory E. Harrington, *NFPA 101®: Life Safety Code*^{® Handbook} (Quincy, MA: National Fire Protection Association, 2009).

Section 2: Major Design Considerations

and telecommunication services. ADA extends comprehensive civil rights protections to individuals with disabilities similar to those provided to persons on the basis of race, sex, national origin, and religion under the Civil Rights Act of 1964.

Title II of ADA is intended to prevent state and local governments (including entities that operate jails) from discriminating against persons with disabilities. The law protects detainees in the jail and others, including staff, program providers, and visitors.

Although at the time of this writing ADA does not require retrofitting existing buildings to eliminate barriers, it does require accessibility for new construction. Under Title II, state and local governments must ensure that newly constructed buildings are free of architectural barriers that restrict access or use by individuals with disabilities. In the case of alterations to existing buildings, the altered portions must be accessible.

It is important for local agencies to be aware of the Title II enforcement provision, which states that private parties and individuals may initiate lawsuits to enforce their rights under ADA Title II. In such cases, local governments may be liable for damages and plaintiff's attorney fees. In fact, in the 2004 U.S. Supreme Court case *Lane vs. Tennessee*, the court upheld ADA Title II as well as its damages provisions.

In addition to private lawsuits, individuals may also file complaints with eight federal agencies under Title II. The U.S. Department of Justice (DOJ) handles complaints specific to correctional institutions.

Under the provisions of ADA, DOJ maintains and enforces technical design standards for compliance with the act. At the time of this writing,

local governments may choose between two standards for accessible design: the Uniform Federal Accessibility Standard (UFAS), established under the Architectural Barriers Act of 1973, or the Americans with Disabilities Act Accessibility Guidelines (ADAAG), published in 1991 and adopted by DOJ for places of public accommodation and commercial facilities covered by Title III of ADA. (The elevator exemption for small buildings under ADAAG would not apply to entities covered by Title II).

Neither the UFAS nor ADAAG, as adopted by DOJ, cover in detail the design standards for detention facilities. However, since its original publication, ADAAG has been revised to include design criteria for public facilities such as detention facilities. DOJ has not adopted the revised guidelines (ADAAG-Interim Final Guidelines); however, these guidelines provide important design criteria that should be used in the design of jail facilities.

Jurisdictions should review UFAS, ADAAG, and ADAAG-Interim Final Guidelines and follow the most stringent requirements of each. Such an approach would ensure compliance with ADA. Jurisdictions should also review state and local accessibility requirements, if there are any. Between local guidelines and UFAS/ADAAG/ADAAG-Interim Final Guidelines, the most stringent requirement will generally prevail.

The following sections provide additional information about ADA and its impact on jail planning and design.

Location or Dispersion of Accessible Cells

Dispersing accessible cells throughout a facility ensures that inmates with disabilities can be housed with other inmates of the same classification.

Basic Features of the Accessible Cell

Wheelchair-bound inmates need to be able to enter their cell, move around inside, and use the cell's furnishings without assistance. Careful planning will incorporate a wider cell door, adequate clear floor space, and appropriate models and placement of furniture and plumbing fixtures (exhibit 11-1). The accessible cells should contain the same features as other cells for inmates housed at the same classification level. For example, if other cells have a writing desk, an accessible writing desk should be provided in the accessible cell.

Furniture, Hardware, and Equipment

ADA specifies the size, height, clear floor space, and placement of the following:

- Desks.
- Dayroom tables.
- Seating.
- Bunks and beds.
- Showers (grab bars and seats).
- Toilet fixtures (grab bars).
- Sinks and lavatories.

Exhibit 11-1. Layout of an Accessible Cell

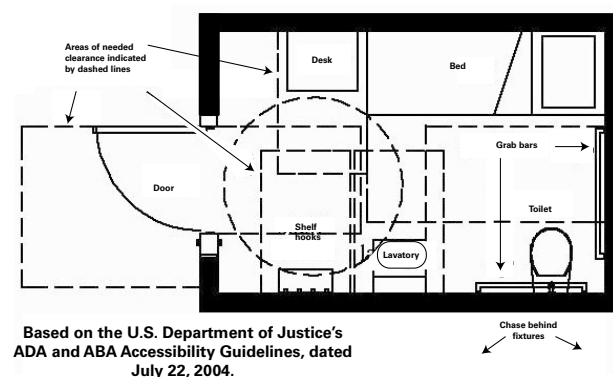

- Mirrors.
- Shelves.
- Alarms.
- Communications (intercoms).
- Doors (width and clearances surrounding the door).
- Door handles.
- Televisions.
- Telephones.
- Visiting stations.

As awareness of design issues for inmates with disabilities has grown, an increasing number of products have become available to meet ADA requirements.

Common-Use Areas

Common-use areas include locations that serve a group of detainees, for example, exercise yards, programming/multipurpose rooms, visiting stations, dayrooms (including shower areas), and medical areas. A common-use area must be accessible if it serves an accessible bed or cell or if it will be used by a detainee who has a disability.

Public and Staff Areas

ADA requirements apply to jail staff and to the public; therefore, these requirements affect all areas of a facility. ADA covers a wide range of disabilities. Although the needs of people confined to wheelchairs receive primary attention from most designers, other disabilities (such as hearing and sight impairments) also require attention when designing a jail facility.

Compliance with ADA is the law for new facilities. Noncompliance can lead to lawsuits and to awards of damages to plaintiffs. Local governments undertaking a jail project must be aware

Section 2: Major Design Considerations

of the latest ADA and other accessibility standards, guidelines, case law, and other laws, and should consider hiring consultants, architects, and/or engineers who are experienced in implementing the requirements of accessibility laws.

Conclusion

Codes and standards are a significant factor in the design of a new jail. The latest versions of applicable codes and standards should be identified

early and applied before design begins (i.e., during the predesign planning stage). Local officials who are familiar with the codes and standards should be involved early in the facility development process.

Special standards developed by national organizations can serve as an important supplement to required state or local codes. Jurisdictions should take the time to find these standards and apply them as necessary in the design of a new jail.

A jail is a large capital expenditure for a community, so it is paramount that the facility has a long and useful life. The key to ensuring the jail's longevity is to plan for future expansion.

Why Plan for Expansion?

Many communities have the foresight to build a jail that not only meets their capacity needs today, but also their projected needs for the next 15 to 20 years. Sometimes these projections are correct, and sometimes they are not. Developing bed capacity projections is not entirely precise because key assumptions that go into formulating the projections may change. For example, the jurisdiction's population may grow or its crime rate may increase faster than anticipated.¹

Totally unforeseen factors can also affect the size of the jail population. Recently, two phenomena—mandatory sentences and overcrowded state prison systems—have increased jail populations, forcing many jurisdictions to build additional beds they did not think they would need. Sometimes the additions are needed within a few years after a new jail opens.

The failure to develop an expansion plan can have significant consequences for a community in terms of public safety and the overall budget. For example, if a jail does not have the ability to expand because of design or site constraints, it could be rendered obsolete because it does not meet the jurisdiction's capacity needs. If the facility is relatively new (e.g., less than 15 years old), it may be difficult to persuade taxpayers to approve funding for a new jail. If that happens,

the jurisdiction may be forced to crowd the jail beyond its capacity—to the detriment of safety and security—or board inmates in other jurisdictions at considerable expense.

Expansion Options

A number of basic options are available to local jurisdictions as they plan their expansion strategy.

Satellite Jail

Many jurisdictions have built “satellite jails” as an adjunct to their existing jail. Typically, they have pursued this course because:

- Site constraints do not permit expansion of the existing jail.
- The existing jail is relatively new and it would not be prudent (for political and/or fiscal reasons) to discontinue its use.
- The jurisdiction is interested in developing a separate treatment or program facility.

The following costs are normally associated with a satellite jail:

- **Site acquisition.** Purchasing a new site could be required if the jurisdiction does not own a suitable parcel of land.
- **Duplicate building components.** Several components of the existing jail (such as exercise and visiting areas) cannot be shared with the satellite jail and must be replicated.
- **Duplicate staff.** The jurisdiction will lose some staffing efficiency because of the need for

¹ For guidance on estimating future capacity needs, see David M. Bennett and Donna Lattin, *Jail Capacity Planning Guide: A Systems Approach* (Washington, DC: U.S. Department of Justice, National Institute of Corrections, 2009).

some duplicate staff (such as shift supervisors) in two facilities.

Double Bunking

Many jurisdictions view double bunking of single cells as an expansion option because it can increase capacity quickly and inexpensively. However, this option has several major drawbacks, which are discussed at length in chapter 27, “Single Versus Multiple Occupancy,” in section 4.

Planned Additions to the Jail

Constructing additions to the jail (such as new housing pods) is the preferred expansion option because it is less expensive and more staff efficient than building a satellite jail. It is preferred over double bunking because the fundamental security and management capabilities of the initial construction can be maintained.

When To Develop an Expansion Plan

Planning for expansion should begin during the predesign planning phase and continue through the development of the facility program because the expansion plan will affect the jail’s site selection, design, and operations. It is important to realize that the expansion plan will greatly affect the initial design of the jail because it will tell the architect how each component will grow and by how much. The architect must then arrange and design the components to allow for that growth. The expansion plan will assist with site selection because it will give the architect information to determine how many square feet are needed for the building as well as the need for off-street parking.

The expansion plan should contain the following information:

- The expansion capacity of the facility (generally, the jail’s ultimate bed capacity).

- How each component of the facility should expand and by how much (in terms of cells, square feet, equipment needs, or policy changes).
- The capacity to increase the amount of parking spaces.

Setting Expansion Capacity

One method for setting expansion bed capacity is to use bed capacity projections developed during the needs assessment step of predesign planning. If the determination of initial capacity is based on a projection for the next 15 years, it would be reasonable to use the same data to project a future expansion capacity for the next 25 to 30 years.

No matter what method or expansion capacity number is chosen, it is best to project for the addition of more beds than may actually be needed. The expansion plan does not mean the jurisdiction is committed to build additional beds; however, if additional capacity is ever needed, it can be accommodated by the building and the site as specified in the plan.

Vertical Versus Horizontal Expansion

Additions to a jail can be built in two ways—vertically or horizontally.

Vertical expansion assumes that future construction will be on top of the existing jail. In the case of housing, expansion is typically planned to be built on top of an existing housing pod, with the new pod having the same basic design and perimeter wall footprint as the pod below. **Horizontal expansion** assumes that future construction will be adjacent and contiguous to the existing building.

The major benefit of vertical expansion is that a smaller site can be used because the expansion will take place on top of the existing building. This may be desirable if the jail is to be built on a small downtown site. However, several drawbacks to the vertical expansion approach should be considered:

- Potential adverse effects of the initial design on future expansion.
- Higher initial construction cost.
- Disruption to facility operations.

Potential Adverse Effects of Initial Design on Future Expansion

If housing expansion is going to be constructed above an existing housing pod, it is usually assumed that the future pod will be designed in the same way as the pod below. This could, however, adversely affect the design of the expansion housing by eliminating design flexibility.

For example, assume that the vertical expansion plan calls for a dormitory to be built above an existing dormitory but, because of changing circumstances, a high-security housing pod with single cells is needed instead of a dormitory. Unless there is major renovation to the dormitory, the high-security housing cannot easily be built above it, because the locations of interior plumbing and mechanical chases are not compatible with high-security housing.

In the same vein, jail standards could change from the time the jail is built to the time when expansion is needed. New standards may dictate different requirements for cell size, dayroom size, number of showers per inmate, and so forth. As in the example above, the housing area below dictates the design of vertical expansion housing to a great extent.

Horizontal expansion, on the other hand, can provide flexibility. It will not be constrained by an existing building footprint or the plumbing and mechanical chases of a housing unit below.

Higher Initial Construction Cost

If vertical expansion is to be used, initial construction costs for the structural elements of the building will be higher because the structure (columns, beams, and so forth) must be designed and built so that it will support the weight of the future expansion construction. The initial design of stairs, elevators, and the mechanical system must also account for future capacity.

Disruption to Facility Operations

Vertical expansion will likely disrupt facility operations during construction because construction workers, tools, and equipment will need to be inside the security envelope. If expansion housing is to be built on top of an existing housing area, that area may need to be vacated during construction. This would be extremely disruptive because the use of beds in that area could be eliminated for a long period of time.

Expansion Concept for Each Component

The expansion plan should not only include an expanded bed capacity, but also an expansion concept for every functional component of the jail. These expansion concepts will tell the designer how each component will accommodate future capacity requirements and will, in turn, begin to dictate design and location. Considerations and options for expanding each component follow.

Master Control

Allowance must be made for future control systems, touch screens, panels, equipment racks,

Section 2: Major Design Considerations

and stations. If the control system is computerized, expansion can be accommodated by adding control screens to the monitor; this does not require much (if any) additional space. If a hard-wire control system is used, space must be allocated during initial construction for panels that will control future locks and intercoms. Since this component is typically buried in the core of the building, it is difficult to expand without major renovation and disruption to operations; therefore, the system should be sized initially to accommodate expansion capacity.

Intake-Release

This component should be sized to accommodate the jail's expansion capacity because it must be available continuously for the intake and processing of arrestees. Renovation or expansion of this area would be extremely disruptive to jail operations.

Property Storage

Many jails store inmate property in garment bags, and this component can be expanded in several ways. First, the area could be oversized initially to accommodate additional hanging racks at a later date. Second, a tiered hanging rack could be used; that is, the lower tier could accommodate the initial capacity and the upper tier could be used for the expansion capacity. Third, the space could be designed to accommodate a hanging conveyor system similar to that found at a dry cleaning business. A conveyor system allows property bags to be stored more compactly, which eliminates the need for additional space. Storage space for bulk property items should also be sized to allow for expansion.

Health Care

This component could be designed for expansion capacity or it could be designed for initial capacity and expanded when the need arises. If the latter option is chosen, the health-care component

should be located on an outside wall so that expansion does not infringe on adjacent components.

Visiting Areas

Visiting areas are typically located in the core of the jail, which makes physical expansion difficult or even impossible. This component can be expanded without enlarging the physical area by increasing the visitation schedule. For example, expanding visitation from twice a week to four times a week will allow twice the number of opportunities for inmates to have visitors.

In direct supervision facilities, visiting rooms are often located in each housing area, with no centralized visitation function. This configuration allows the number of visiting rooms to be expanded easily as the facility grows.

Another design consideration, video visitation, is becoming more common in newer facilities. With this option the visitor comes to a central site (either inside the jail or at a remote location) and visits with the inmate via video camera. In most cases, the inmate can access the video visitation booth in the housing area.

Exercise Areas

This component can be expanded in two ways. First, the number of hours that the exercise area is available for use by inmates can be increased. Second, new exercise areas can be built as part of housing expansion instead of enlarging existing exercise areas.

In direct supervision facilities, exercise areas are often attached to each housing area; as new housing pods are built, new exercise areas will be attached.

Programs and Services

The number of hours per week that programs and services are offered can be increased if the

schedule allows. Otherwise, new space would be required for expanded programs and services.

Inmate Commissary

Expansion can be accomplished by building a commissary storage area large enough for a high-density storage system at a later date or by locating the commissary on an exterior wall so that it can be physically expanded.

Food Service

Extra space can be provided for the addition of food service equipment when bed capacity is expanded, or the kitchen can be located on an outside wall and physically expanded. Physical expansion of this component, however, can be difficult because of the precise arrangement of equipment in specific work areas, including storage and receiving, food preparation, cooking, meal tray assembly, and cleanup. Special mechanical considerations such as exhaust ventilation, gas lines, and drain lines also make physical expansion difficult. Jurisdictions often choose to over build the kitchen in anticipation of increases in the inmate population.

Laundry

The laundry operation can be expanded by increasing the number of operating hours, by providing space for additional equipment when capacity is added, or by locating the laundry room on an exterior wall and physically expanding it.

Lobby

The lobby is typically sized to allow for the facility's expansion capacity.

Administration Area

The administration area can be sized to accommodate the maximum number of staff or can be located on an exterior wall and physically expanded. It is always a good idea to include extra square footage or extra offices in the area as part of the initial construction because additional administrative staff are often added before jails reach the point of expansion.

Staff Areas

Locker rooms are typically sized for expansion capacity and for the maximum number of staff. However, they could be located on an exterior wall to permit physical expansion.

Storage Areas

Some storage areas can be added when additional housing is built. For example, a new mattress storage area or linen storage area could be built as part of new housing expansion so that it can be located closer to the housing areas it serves. Another alternative is to use high-density storage systems at a later date if feasible. Separate stand-alone buildings could be used to provide storage for areas that do not have security concerns.

Conclusion

It is difficult, if not impossible, to predict how the needs of a jail may change in the future. Jail expansion concepts that are easy to execute, cause minimal disruption to existing day-to-day operations, and permit flexibility in future design will serve the community for decades to come.

Section 3

Functional Components

Chapter 13. Master Control	117
Chapter 14. Intake-Release.	127
Chapter 15. General Housing	149
Chapter 16. Special Housing	181
Chapter 17. Health Care	199
Chapter 18. Visiting Areas	213
Chapter 19. Exercise Areas.	225
Chapter 20. Programs and Services	237
Chapter 21. Inmate Commissary	251
Chapter 22. Food Service	255
Chapter 23. Laundry Area	265
Chapter 24. Administration and Public Areas	271
Chapter 25. Staff Areas	285
Chapter 26. Storage Areas	295



Functional Components

This section contains detailed information on the purpose and design of the major functional components of a jail. This information is organized to provide local officials, board members, and planners with a sound background in the fundamental issues, characteristics, and concepts of each major component. This information should help local sheriffs, commissioners, and planners create a solid foundation from which to develop a detailed set of plans that responds to unique local jail needs.

All of the sections are organized alike. The following kinds of information are provided for each functional component:

- Description of the function.
- Key decisions to be made regarding the function.
- Detailed functional requirements and impacts on the design (detail issues).
- Space list (a list of the spaces associated with the function).
- Relationship diagram(s).
- Component diagram(s) (a diagram that details all of the components in a particular space).

The concepts addressed in section 2, “Major Design Considerations,” are discussed throughout the following chapters. The link between sections 2 and 3 is critical because, as the following pages show, a design is truly the result of the functional and operational needs of facility users—needs that are determined during pre-design planning.

Chapter 13

Master Control

The basic function of master control (also referred to as “central control”) is to serve as the monitoring and control center for all communications, life safety and security systems, and all general building movement patterns, including entries and exits through the main security envelope of the jail. Master control may also function as a point from which some inmate housing units or other inmate or public areas are monitored. In smaller jails, it might also be combined with the law enforcement dispatch function and handle public reception during some or all shifts. In some very small jails, master control may serve as the only secure, fixed staff post within the facility and is truly the “nerve center” of the operation.

All jails, including very small jails, have traditionally had some sort of control center, even if it consisted only of an unprotected control panel



Computerized master control room with two staff stations.
(Photograph courtesy of Voorhis Robertson Justice Services.)

in a relatively insecure room. In smaller jails, the only reason the control post was staffed 24 hours a day often was because it also doubled as the dispatch center for the law enforcement agency affiliated with the jail.

Key Decisions

The following decisions should be made as the role of the master control component is evaluated because decisions made here will have a fundamental effect on design requirements:

- Will master control only monitor electronic security and safety systems, or will it have other responsibilities such as lobby reception, housing area surveillance, intake-release area surveillance, record keeping, answering outside telephone calls, supervising visiting, or receiving packages? That is, what are master control’s responsibilities and how many staff will be needed to do the job?
- Where must the master control space be located to function effectively in conjunction with other facility activities and still be adequately protected from assault?
- Will the master control function be combined with the law enforcement dispatch function? Can both jobs be done by one person throughout the life of the facility? Are both functions compatible in terms of security, since the loss of master control to an inmate takeover would also mean the loss of all law enforcement communications?

Detail Issues

The details of the functional-architectural issues discussed below should be considered in the development of the master control component.

Users

ISSUE: Use of the master control center should be principally limited to master control staff.

RESPONSE: The need for security in master control clearly precludes access to the space by inmates or the public, but access by jail staff should also be limited. Routine communications and contact between master control and other officers should be accomplished through means such as intercoms, radio communication, and passthroughs rather than by entry into master control. Master control should not serve as the focal point for staff breaks or periods of inactivity, as it does in many facilities.

Activities

ISSUE: Master control functions must be identified and priorities set in terms of tasks and workload responsibilities.

RESPONSE: Experience with newer jails has shown that it is easy to overburden this vital position. Facilities with as few as 20 beds can have noticeable difficulty using a single master control position effectively for many jail functions when master control is also responsible for law enforcement dispatch functions.

Examples of master control jail functions:

- Monitoring electronic surveillance systems (audio, closed-circuit television (CCTV)).
- Controlling entries to and exits from the secure perimeter of the facility.
- Monitoring various building systems (radio, surveillance alarms, perimeter lighting, and other mechanical and electrical systems).
- Monitoring and facilitating all internal staff and inmate movement.



Combined law enforcement dispatch and jail master control functions, with one staff member.

(Photograph courtesy of Jim Rowenhorst.)

- Serving as the communications center for the facility, including receiving and/or handling telephone calls.
- Maintaining and monitoring necessary security/safety equipment, such as fire alarms, smoke and thermal detection systems, self-contained breathing apparatus, key lockbox, flashlights, and storage for riot gear (e.g., batons and restraints).
- Monitoring and assuming final responsibility for inmate counts.
- Producing and/or managing jail records and logs.
- Distributing keys, logs, radios, flashlights, and other equipment to staff.
- Exchanging packages and paperwork with the public and mail with postal workers and receiving bail and commissary moneys.

- Monitoring staff shift changes, including identification checks and logging of arrivals and departures.
- Providing surveillance of adjacent housing units and inmate activity areas.
- Providing surveillance of special temporary holding areas, such as those for the mentally ill or intoxicated.
- Providing primary or backup observation and/or monitoring of:
 - Public lobby or night vestibule (i.e., public access).
 - Main jail corridors.
 - Elevators.
 - Housing units.
 - Visitors (public, attorneys).
 - Vehicle sallyport.
 - Intake-release area.
 - Temporary holding cells.
 - Multipurpose or indoor exercise room.
 - Outdoor exercise areas.
 - Storage of bond moneys and legal documents.
 - Storage of prescription medicines and first-aid kits.

Examples of master control law enforcement-related functions:

- Radio dispatching of patrol cars.
- Receiving incoming department telephone calls.
- Handling of 911 emergency system.
- Dispatching ambulance services.
- Coordinating emergency disaster dispatching.

- Monitoring fire alarms and burglar alarms at local businesses and institutions.
- Record keeping and computer data entry.
- Managing national, state, and/or local criminal data systems.

It should be clear that combining the many functions just described for law enforcement with those for the jail would create an unmanageable situation for one person to handle on some or all shifts. However, with staff at a premium, good planning should attempt to get the most from the master control post without sacrificing facility security and staff and public safety.

A full evaluation of the workload of master control is warranted prior to the design phase. Such an evaluation should take into account future change and workloads because master control may require two people rather than one on certain shifts. For smaller systems that combine the functions of master control and dispatch, be aware that all control of the jail and all security and communication links within the county may be severed if the space is overtaken by inmates.

Security

ISSUE: Master control should be able to control the entire facility if necessary.

RESPONSE: In the event of a disturbance, a fire emergency, or an equipment breakdown, master control should be able to secure and control the facility. For example, if there is a second housing control post by which other staff supervise or manage a housing area, master control should have the operational capability to override those controls if need be.

In fulfilling the backup role, master control may need to release multiple cells simultaneously, remotely open housing unit dayroom doors, and

Section 3: Functional Components

allow egress of inmates to a safe holding area. As a primary function, master control must be able to remotely allow entrance of emergency personnel into all areas of the building. Master control should also maintain a master set of jail keys for manual override of locking mechanisms in case of a power loss (although emergency power generation should be a feature of all jail designs).

ISSUE: The construction of the master control area must be fundamentally secure to preclude access by inmates and the public.

RESPONSE: Because master control is the “nerve center” of the jail and may also contain the law enforcement communication center, the creation of a physically secure space is vital. A secure envelope must be created for master control; that is, the walls, floor, and ceiling of master control must be constructed of secure materials.

A secure ceiling is particularly important because many buildings have a ceiling plenum (an area between the ceiling and the roof or floor above for structural beams, ductwork, electrical conduit, and so forth). If inmates penetrate the plenum, they might gain access to master control through the ceiling unless the ceiling is of secure construction (e.g., concrete, steel decking, or cement plaster with metal lath). An alternative to secure ceiling construction is to extend the security walls of the space up past the ceiling to the floor or roof construction above.

Selection of the correct security glass product is also essential to creating a secure envelope. In selecting detention glass, remember that no security glass product is impenetrable or shatterproof, only penetration-*resistant* and shatter-*resistant*. Penetration resistance is the primary need in master control because the glass must at least delay, if not prevent, unauthorized access.

Shatter resistance is a lesser, though still important, issue. Glazing panels should be as wide as possible to maximize view without interruption by normally thick security framing. Panel height should be examined carefully where vertical view relationships are important.

ISSUE: All openings into master control must be secure.

RESPONSE: Besides the obvious opening of the entry door, other critical openings that must be able to be secured include passthroughs, air supply openings, and electrical openings.

Secure entry is often handled by creating a vestibule into the master control area. The doors to the vestibule are normally “interlocked,” that is, they cannot both be opened at the same time unless the interlock is purposely overridden (a capability that should exist). Doors normally swing inward so the master control officer can barricade them shut if need be.

A vestibule created solely for access to master control requires valuable square footage and can impede views to other areas. One approach in response to this issue is to allow the vestibule entry to the secure perimeter (which is frequently adjacent to and monitored by master control) to double as the secure entry to master control (exhibit 13-1).

Another important issue in a jail in which there is only one master control officer is to provide a means of access to master control in case the officer becomes incapacitated. One such means is a key kept in another secured area that is readily accessible to authorized staff.

Passthrough openings for keys, packages, walkie-talkies, and paperwork serve to prevent the introduction of such dangerous items as chemical agents, explosives, or firearms. These openings

Exhibit 13-1. Entry to Secure Perimeter
Doubles as Secure Entry to Master Control

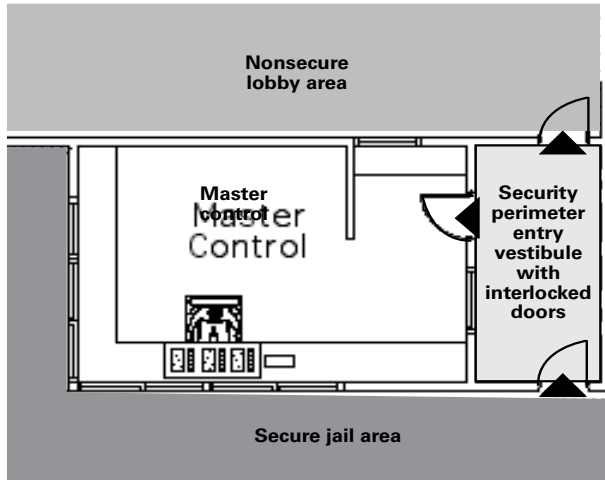

should be designed to prohibit opening by anyone but the master control officer. Openings for heating and air-conditioning ducts and electrical openings for light fixtures and outlets should also be secured to prevent access.

ISSUE: All power, communication, and computer lines outside the master control space must be secured.

RESPONSE: It would do little good to secure the master control space if the sources of its power and capabilities were vulnerable. Consequently, the electrical, mechanical, and emergency power sources for the facility must be protected. If control center computers are housed in a room outside the master control area, they must also be secure.

Electrical panels that contain relays, switches, and wiring for control systems must also be protected, as must the electrical lines carrying power between master control and the locks, intercoms, and monitoring systems under its control.

View

ISSUE: When master control is required to provide monitoring in specific areas, the design should allow for effective visual observation of those areas.

RESPONSE: If master control is to provide backup or principal monitoring of an area, a direct line of sight to that area should be created wherever possible in lieu of reliance on CCTV monitoring. Direct visual observation is more effective and has the secondary benefit of letting inmates know they are under observation.

A difficulty with the master control position providing direct visual observation of various activities arises if master control is expected to observe too many things. When this occurs, master control can become an overly large and unwieldy space in order to be next to, or in view of, everything (exhibit 13-2). As the planning team increases the responsibilities of the master control position and the control space gets larger, they must determine the precise location of the master control staff and equipment. The desired view and the proximity of master control to different spaces may not be attained when the

Exhibit 13-2. Master Control Position Expected To Observe Too Many Things

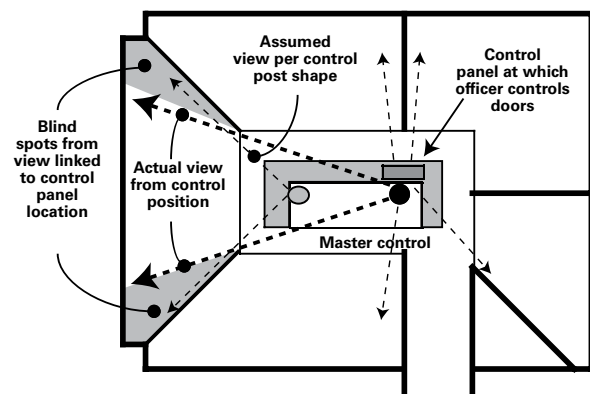

Section 3: Functional Components

actual location of the staff position is established. Unanticipated blind spots or excessive movement away from the control panel may compromise staff's ability to view key areas.

ISSUE: Views into and through master control should be controlled.

RESPONSE: When master control becomes the hub of a series of adjacent activities that it monitors, the prospect of view conflicts between spaces arises. Inmates may see through master control to public areas, be able to view control boards and computer screens in master control, or be able to view or communicate with inmates of the opposite sex in other areas.

Several approaches can be taken to prevent these problems:

- Minimize the potential for view conflicts by minimizing the number of areas that master control must directly observe.
- Use equipment or partitions in master control to screen views.
- Raise the floor height of master control to help limit views into the control room (exhibit 13-3). With this technique, it is important to ensure that the control platform is not so high that it eliminates a line of sight between the master control officer and the floor officer or between the master control officer and inmates in adjacent areas. The capability for convenient communication between master control and roving staff and the ability to pass logs, keys, and other items between them should be preserved. In establishing proper floor height and sightlines, be sure to factor in the location and height of control panels and television monitors.

Exhibit 13-3. Floor Height of Master Control Raised Above Dayroom and Corridor

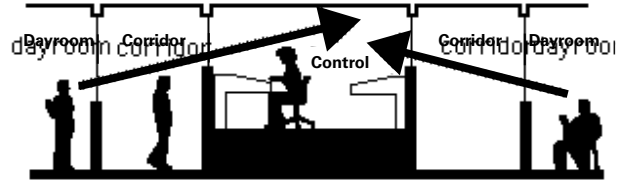

- Selectively apply reflective, one-way, or tinted glass to the master control area or to the inside of the rooms from which view conflicts arise. However, such glass severely limits contact and interaction between master control and inmates, the public, and other staff. Tinting or mirroring also affects the intensity of lighting required in adjacent spaces monitored by master control. If tinting is not uniformly applied to all master control glass panels, internal light reflections off the glass can erode view quality.

Another critical view conflict often arises in smaller jails when dispatchers operate master control and become uncomfortable being visible to inmates. Their response is often to screen themselves from view, thus defeating the location and design of master control. The solution may lie in the selection and training of staff rather than in the design. See chapter 9, "Criminal Justice Interface," in section 2.

Design Efficiency

ISSUE: Master control must be laid out efficiently.

RESPONSE: Control panels and/or touch screen monitors should be within easy reach of the officer (exhibit 13-4). (**Note:** The use of hard-wired control panels is not recommended in the design of any new facility, as such panels are not easily changed or expanded and can be difficult and cumbersome to use and repair.)

Exhibit 13-4. Preferred Control Panel Configuration

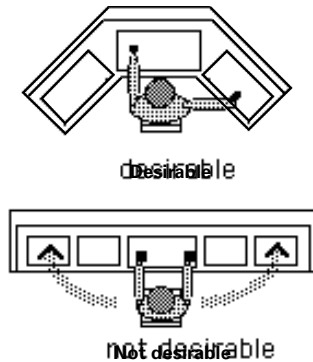

Control panels can be organized independently of each other by function (locks, lights, intercom) or together on one panel by the physical location in the building to which the functions correspond (that is, locks, light, intercom grouped together by space—e.g., dayroom, cell). Touch screens can be customized by area using separate screens on a single monitor.¹

Grouping frequently used controls by the location to which they correspond is more efficient, although it can be more costly and complicated to install and can result in very large panels if a hard-wired system is used rather than a computerized touch-screen system.

It is important to the design to determine whether the staff assigned to master control will sit or stand. If the nature of the post requires frequent movement around the space, standing or sitting on a high stool might be preferred over a low seat. This decision must be coordinated with decisions regarding the design of the master control area and of the sill and head heights of glass view panels in the walls.

If control staff are constantly leaving their equipment and moving around the master control space to do all the jobs required and to obtain all the necessary views, the master control task may become quite frustrating and inefficient. Reducing control functions and switching duties to other staff might be a better solution.

Ready accessibility to such things as life safety annunciator panels, bulletin boards, inmate location charts, post orders, and egress plans frequently demands that some solid wall space be provided in master control. Thus, it is difficult to provide a totally efficient, fully glazed space. This may be beneficial, though, because it can be overly stressful to work in what some refer to as a “fish-bowl” environment.

Environment

ISSUE: The master control environment should reduce stress and fatigue and enhance control activities.

RESPONSE: Sound-absorbing materials such as carpet and acoustic ceiling tile can reduce sound reverberation (echoes) and the harshness of sound that could easily result from the incessant noise of master control equipment.

Temperature and ventilation are critical considerations because the equipment within master control frequently generates excessive heat. To alleviate this problem, it would help to make special or separate provisions to cool and ventilate the master control space and to give some control over these conditions to the staff. Separate provisions also aid security because they make master control less vulnerable to attack and help eliminate the transmission of unwanted sound

¹ Hard-wired systems rely on buttons and wires for each lock, camera, intercom, etc. Touch-screen systems rely on a computer monitor with multiple screens and symbols representing functions, with coded signals being sent through a few wires to the lock or other function involved.

Section 3: Functional Components

from inmate-occupied areas that can result from improperly designed ductwork.

Giving the master control officer the ability to control the intensity of direct and indirect lighting can be helpful in minimizing eyestrain by reducing glare and reflections from monitors and glazing. It also helps balance light levels between touch screen monitors, CCTV monitors, panel lights, adjacent rooms, and the master control area.

Even though frequent staff breaks are recommended, master control staff should be able to get a drink of water and use restroom facilities without leaving the master control space. Therefore, having such facilities accessible from within master control is very desirable. A place for a coffee pot may also be desirable.

Communication

ISSUE: Easy communication should be provided throughout the facility.

RESPONSE: Master control should be linked by telephone or intercom to all key areas of the facility, including all staff control posts and work areas. A facilitywide public address system is not appropriate for point-to-point communication between staff where privacy or discretion is desired.

Continuous communication with officers not assigned to a constantly staffed post (rovers) or with transport officers may require the use of a portable radio system. An officer duress system, tied to alarms at master control, can be incorporated into the portable radio system to provide additional officer safety. Master control should also have some means by which to communicate to all housing units and major areas used by inmates in case other control posts become inoperative.

Communication between master control and adjacent spaces always seems to be a special problem in new jails owing to the use of security glass, concrete block, and other materials that effectively form solid walls through which sound does not transmit. It is advisable to use electronic devices or secure portals through which direct voice contact can be established. In either case, the convenience of the users should be taken into account.

Portals to public areas should be secure; electronic communications are preferable. Direct two-way visual contact between the control officer and the public visitor tends to be preferred by both parties.

Equipment

ISSUE: The sophisticated electronic control and communication equipment needed in modern jails must be accommodated.

RESPONSE: Master control has become a very sophisticated element of the modern jail.



Master control observing a housing unit.
(Photograph courtesy of Kimme & Associates.)

It tends to rely heavily on computer-based controls, detection devices, and communications. With this technology comes the need to provide adequate secure space for the equipment needed to facilitate master control operations. Ideally, this equipment should be housed in a secure room off the master control area and within the secure envelop of the master control area.

Fire Safety

ISSUE: Proper fire safety provisions are essential within master control.

RESPONSE: Although planners must check local codes for specific fire safety requirements, several general considerations for fire safety in master control should be noted:

- Master control should use fire-suppression systems that minimize equipment damage.

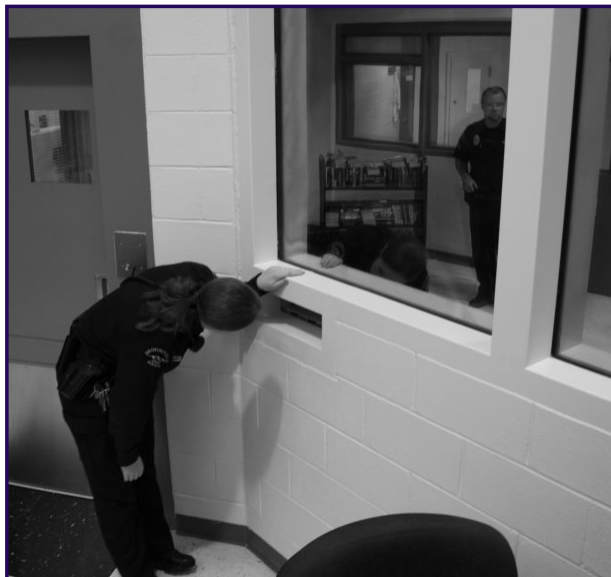

Awkward mode of communication between master control and roving officer.
(Photograph courtesy of Kimme & Associates.)

- A fire extinguisher and self-contained breathing apparatus (air pack) should be available in master control.
- A direct alarm link to the fire department should be available in master control.
- Provisions for smoke evacuation or blocking smoke movement from other areas into master control should be considered.

Expansion

ISSUE: The design of master control should consider and accommodate expansion of the area.

RESPONSE: Master control is not easy to expand because of its nature and generally central location in the jail. Therefore, if workload demands are likely to increase to the point where two or more positions are needed, it would be wise to design master control as a multiple-position space from the start. Such a design must account for appropriate space and arrangement as well as consider how the extra posts might split or share functions, thereby requiring some duplication of equipment and power sources.

Space List

Some of the typical spaces that might be found with the master control component include:

- Master control work space.
- Dispatch work space (if combined with master control in small jails).
- Restroom.
- Computer/electronic equipment room.

**Section 3:
Functional Components**

- General storage/equipment storage room.
- Interlocked security vestibule.

Local codes and ADA guidelines regarding accessibility requirements should be consulted when planning these spaces.

Relationships and Components

Exhibit 13-5. Master Control Component Diagram

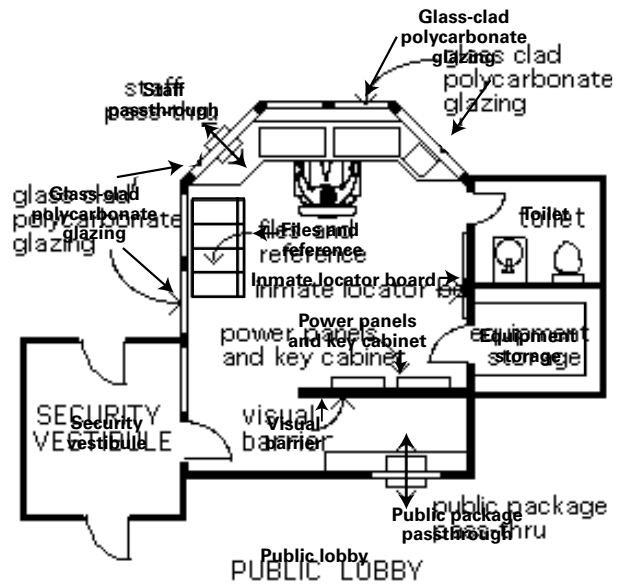

Chapter 14

Intake-Release

The intake-release area of a jail—often referred to as booking, admissions, or receiving—is an active, vital component of any jail operation (exhibit 14-1). This area is used for three critical jail functions:

- Conducting all intake activities involved in initially receiving arrestees from the field or inmates from court or other facilities:
 - ❑ Secure entry/verification of arresting authority.
 - ❑ Searches.
 - ❑ Receiving and temporarily storing selected arrestee property.
 - ❑ Booking, fingerprinting, and photographing arrestees.
 - ❑ Temporary holding of arrestees.
 - ❑ Interview/visiting space or telephone access for bonding agents.
 - ❑ Screening/interviewing of arrestees by law enforcement, parole, probation, or others.
 - ❑ Preliminary medical and suicide screening.
 - ❑ Providing minor first aid.
- Conducting all intake activities involved in admitting arrestees or processing arrestees before they are moved to a housing unit:
 - ❑ Exchanging personal clothing, dress-out into facility-issued clothing.
 - ❑ Shower/decontamination.
 - ❑ Searches.
 - ❑ Storing personal and facility-issued clothing/property.
 - ❑ Inmate orientation to facility services and rules.
 - ❑ In-depth health and suicide screening.
 - ❑ Initial inmate classification.
 - ❑ Movement to housing unit.
- Conducting all activities involved in releasing arrestees or inmates from either the receiving area or a housing unit:
 - ❑ Verifying identity.
 - ❑ Executing release paperwork.
 - ❑ Exchanging clothing, dress-out.
 - ❑ Returning property.
 - ❑ Providing secure exit.

Many facilities are designed with a separate release area where inmates turn in facility-issued items, dress in their personal clothing, receive other personal items that were in storage, and

Exhibit 14-1. Intake-Release Area

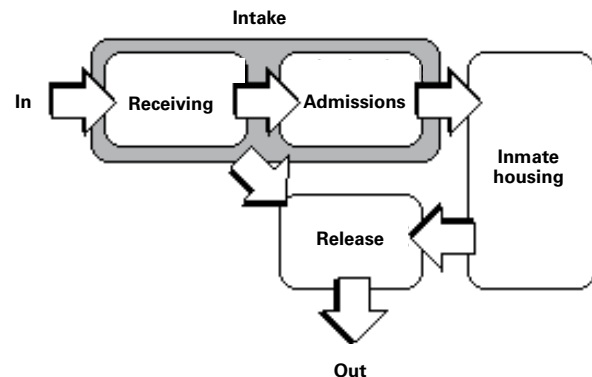

complete release paperwork without disrupting the booking operations.

The intake-release area provides the arrestee with his/her first impression of the facility and sets the tone for his/her stay, much in the same way that the jail's public lobby and reception areas influence the public's first impression. Architecturally and operationally, the intake-release area sets the stage for subsequent inmate behavior by what is communicated verbally and nonverbally when the arrestee first comes into custody.

The intake-release area is used frequently because every arrestee or inmate who enters the facility is in this area at least once. In addition, at this point arrestees and inmates can be in various mental and physical states (e.g., angry, intoxicated, emotionally disturbed). Therefore, the planning and design of this area require special care and attention. The result should be a set of spaces that allow staff and inmates to function in a safe, secure, calm, and orderly way that preserves human dignity to the greatest extent possible.

Modern jails provide much more space for intake and release functions than the typical jail of the past. Few older jails provided secure and protected vehicle sallyports or temporary holding capabilities; instead, the inmate waited in the booking area or was moved directly to a cellblock. In many older jails, processing arrestees for housing occurred without a shower or a change of clothes and without any screening for medical and mental health problems. Booking areas in older jails were rarely within a fully secure perimeter and sometimes were combined with the dispatch function in an area accessible to the public. Over the years, litigation forced staff to squeeze many of these needed but neglected functions into whatever limited space might be available (e.g., hallways, storage spaces, or closets). The results were often far from satisfactory.

Modern intake-release areas tend to provide space for a full variety of intake-release functions and to consolidate them into one distinct complex of interrelated spaces within the jail's main security perimeter.

Key Decisions

In evaluating the role of the intake-release component, the following decisions must be made because they have a fundamental impact on design requirements:

- Will officers with arrestees enter the jail through a secured vehicle sallyport or will they park in, and move through, unprotected outdoor areas to gain access to the jail?
- Will the arresting officer assist in the receiving and admitting process or can his/her involvement be limited to minimize the tension between the arrestee and officer that results from an arrest?
- Will the arresting officer interview the inmate at the jail prior to booking to gather information for completing reports or will this take place prior to arrival at the facility?
- Will arrest procedures (such as administering a breathalyzer) be conducted at the jail or at some other location prior to arrival at the jail?
- Will the facility accept intoxicated, mentally ill, or injured persons or can they be taken directly to alternative facilities? If they are accepted at the jail, will specially trained staff and designated areas be made available to accommodate them?
- Will there be a release area separate from the receiving and admissions area or will release occur in the same area?
- Will inmates housed in the facility wear clothing provided by the facility or their personal clothing?

- Will females be processed in areas separate from those used for males or does the design, supervision, and scheduling effectively eliminate any problems that may result from using one area?
- Will the booking area be staffed at all times or will staff only be present when an intake or release occurs?
- Will inmates waiting for transportation to or returning from court be staged in the booking area or another holding area?

Detail Issues

Following is a discussion of the detailed functional-architectural issues to be considered when developing the intake-release component. Because the design of the intake-release area involves many complex questions, the issues are divided into four categories: general design, receiving area, admission area, and release area.

General Design

These issues pertain to the entire intake-release area: users, location, arrangement, environmental quality, and security.

Users

ISSUE: Identify those who will use the intake-release area so that the space can be planned and designed effectively.

RESPONSE: Jail staff (including correctional officers, medical personnel, and support staff), new arrestees, and law enforcement officers will use the intake-release area most frequently. Intake-release staff must process all inmates for admission into the facility or for pretrial release via bail, recognizance, citation, or third-party release. Local law enforcement officers will use the area to deliver arrestees for receiving. Other law enforcement officials (e.g., federal marshals or

Immigration and Customs Enforcement officers) might use the area for temporary detention of inmates in transit. Court officers or transport personnel may use the area for staging to prepare inmates for transport to and from court, appointments, or transportation to other agencies. Probation and parole officers may use the area to temporarily hold violators or to interview arrestees who may be eligible for pretrial release programs.

A variety of arrestees and inmates might use the receiving area and shape the space needs. Some of the disparate behaviors and characteristics typically encountered include:

- Scared and unpredictable.
- Violent and angry.
- Nonviolent and passive.
- Career criminals.
- Average citizens.
- Males.
- Females.
- Juveniles charged as an adult.
- Intoxicated on drugs or alcohol.
- Injured.
- Physically or mentally disabled.
- Suicidal.

Others who may use the area intermittently or frequently include medical and mental health personnel, bondspersons, attorneys, and pretrial services personnel. Because they may need work space in the intake-release area at the same time that law enforcement and jail staff require space, the feasibility of all users sharing the same space or needing several spaces must be considered.

Section 3: Functional Components

The size of the receiving area and requirements for separate spaces and other amenities should be based on actual historical booking records and future projections of receiving and admissions activity. It is critical to recognize that the number of arrestees or inmates in the intake-release area at any one time can vary greatly based on the following factors:

- Unusually busy times (weekend nights or during transfer to court).
- Length of stay in temporary holding.
- Group arrests.

In determining the number of users, it is important to consider that an arrestee's average length of stay in the receiving area of a newer jail might be longer than that in an older jail because most newer jails provide a holding capability in the receiving area. This allows the arrestee to spend several hours in the intake area while trying to arrange release or while waiting for others to make arrangements, rather than being moved to a housing unit shortly after booking. The admission process is completed only after it becomes apparent that release will not occur in a timely manner and that the inmate should be moved to a housing area. Adequate staff supervision must be provided for arrestees in the intake area.

Location

ISSUE: The location of the intake-release area is vital to the facility's efficient operation.

RESPONSE: Following are the key criteria for the location of the intake-release area:

- Within the secure perimeter of the facility.
- Adjacent to a controlled entrance to the building such as a vehicle sallyport or entry vestibule. In smaller jails, it is often



located within view of master control because this station will likely control all access to the building and provide visual backup for the area.

- Near the public lobby to allow a convenient and dignified release.
- Near visiting or interview areas to allow access to friends, family, attorneys, and bondspersons who are integral to inmates' release or who help with personal matters.
- Near the medical examination area to allow easy access to these services. It is often convenient to have a medical examination room in the booking area so arrestees can easily be screened prior to moving to a housing area or receive emergency medical attention if they need it.
- Near cells used for mentally ill or intoxicated individuals, if such cells are not provided in the intake-release



Entrance into receiving area from vehicle sallyport.
(Photograph courtesy of Jim Rowenhorst.)

area. These cells should be quickly accessible from the secure entry to minimize the difficulty of moving these individuals. In addition, these cells should be observable from a post that is constantly staffed.

- Near the laundry or clothing storage area, if inmates will change into facility-provided clothing prior to entering a housing unit.
- Near offices of personnel involved in pretrial screening and near interview rooms they or others might use.

Exhibit 14-9 at the end of this chapter illustrates these relationships.

Arrangement

ISSUE: The arrangement of intake-release spaces must facilitate inmate and staff flow and ensure the area's integrity and functions.

RESPONSE: A series of primary flow sequences occurs in an intake-release area. They should be charted in sequence to identify the types of spaces needed and their fundamental arrangement.

The different types of flow that may occur in the intake-release area include:

- Receiving an arrestee.
- Receiving and admitting an inmate transferred from another facility.
- Readmitting an inmate who temporarily left the facility.
- Processing an arrestee for housing.
- Releasing an arrestee prior to admission.
- Releasing an inmate after a stay in a housing unit.

- Releasing an inmate for a court appearance.

It is generally recommended that work release inmates enter and exit the facility through a separate access point. However, this may be impractical and unnecessary for a jail that has:

- A very limited capacity.
- A low arrestee receiving and release rate, which suggests minimal potential conflicts and a greater ability to concentrate on the management of contraband problems through staff and policy.
- A need to use space and equipment in the intake-release area because duplication cannot be justified.

However flow is projected to work through the intake-release area, all spaces in the area should be consolidated into one distinct group of spaces that work together and are uninterrupted by other nearby activities and functions. That is, pieces of the intake-release area should not be scattered throughout the facility. Consolidation allows for smooth and effective operations and helps retain the arrestee's privacy and dignity because, for many arrestees, contact with the jail can be successfully limited to the intake-release area alone. (As many as one-third of all arrestees might be released within the first 6 hours of stay and two-thirds within 72 hours.)

In this regard, it is important to ensure that there is proper separation between the spaces involved with receiving and those involved with processing arrestees before transfer to a housing unit, which requires more privacy (e.g., shower, dress, unclothed body search (if applicable)). Particular attention needs to be given to privacy because both male and female arrestees will likely use the intake-release area in all but the largest jail systems.

Section 3: Functional Components

Environmental quality

ISSUE: The intake-release environment should help reduce tensions and create a calm, orderly, and secure intake process.

RESPONSE: Although the creation of a calm, pleasant, and orderly atmosphere is in many ways dependent on staff attitudes, architecture can help considerably. Such an atmosphere can help reduce initial tensions and anxieties and thereby reduce the potential for aggressive behavior by arrestees. When the appearance and atmosphere of the intake-release area is normalized it communicates an expectation of rational behavior and often produces that result (exhibit 14-2).

The area's appearance and character—and how individuals respond to it—can be improved in a number of ways without sacrificing security. Possible techniques, which should be used selectively depending on different types of inmates and staff considerations, include:

- Using more conventional construction materials, such as concrete masonry units and security glass instead of steel plate and bars.

Exhibit 14-2. Detailed View of Intake-Release Area in a Smaller Jail

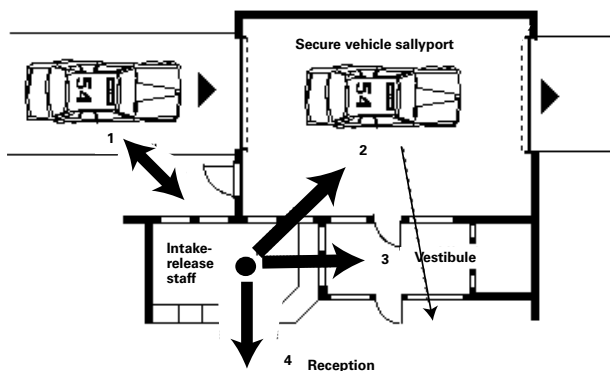

- Using “softer” materials that add warmth to the area and improve acoustics, including:
 - Carpet.
 - Lay-in acoustic ceiling tile.
 - Durable but more attractive furnishings, such as plastic and wood, rather than concrete and metal in waiting areas.
 - Solid-core wood doors for holding cells for compliant, nonviolent arrestees.
- Using warm and bright colors rather than institutional colors and patterns.
- Providing normalizing diversions such as television and magazines.
- Providing maximum freedom in holding accommodations, such as open waiting areas for arrestees who do not require a more restrictive setting.
- Providing easy access to telephones for arrestees to use to secure bail or make other arrangements.

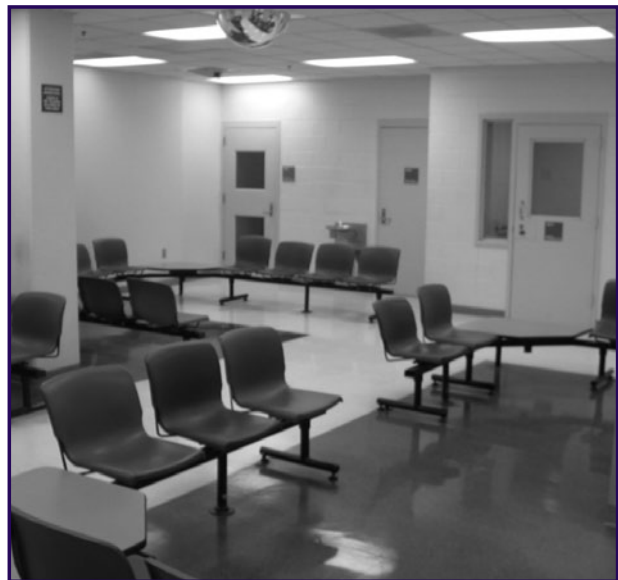

A light, clean, and comfortable arrestee waiting area with open seating. (Photograph courtesy of Jim Rowenhorst.)

Overall, the intake-release area should create an appearance similar to that of a well-designed waiting area in a clinic; at the same time, the underlying construction approach, a well-defined security zone, and staff supervision can enhance the ability to segregate and restrain disruptive inmates when needed.

Security

ISSUE: Because of the sensitive and difficult nature of intake-release functions, close security and control are required.

RESPONSE: Given the emotional stress and unpredictable behavior involved in the receiving process and the potential for security problems during receiving, admissions, court transfers, etc., intake-release area functions need to be among the most secure and closely monitored in the facility.

The entry sequence to the receiving area should be within the direct line of sight of the intake-release officer. Ideally, although master control will control the entry and exit doors, intake-release staff must be able to directly view:

- Entry of the vehicle into the sallyport.
- The officer and the arrestee leaving the vehicle.
- The identity and circumstances of the transporting officer prior to authorizing master control to open the vehicle sallyport door.
- Movement to and through the door or vestibule leading to the receiving area.
- Departure of the officer from the entry vestibule.
- Departure of the officer and vehicle from the vehicle sallyport.

This arrangement has the following advantages: the intake-release officer can view the entire entrance process and respond if trouble arises; the arresting officer is confident that the situation is under control, and the arrestee is deterred from dangerous behavior by the intake-release officers' constant and visible support; and the arrestee can see where he/she is going next, thereby relieving anxiety about the process.

If possible, in smaller facilities the same sequence should be visible from a constantly staffed post such as master control because it will probably have responsibility for operating sallyport and entry doors. Any view that cannot be provided to master control directly should be provided through closed-circuit television (CCTV). Holding cells and the booking, fingerprint, and photograph areas should also be visible from master control or a constantly staffed post.



Receiving (“Booking”) Area Design

The following detailed functional-architectural issues pertain to the areas required for the receiving or “booking” activities of the intake-release component. The receiving areas and spaces are those involved when the arrestee is initially received, but they are not involved with the process of preparing inmates to be moved to housing, inmates returning from court, or inmates transferred from other facilities. The following discussion of the receiving area covers secure entry, arrestee processing, waiting and temporary holding, outside contact, and miscellaneous support.

Secure entry

The secure entry typically consists of two primary architectural elements:

- Vehicle sallyport.

Section 3:
Functional Components



Booking area with large windows (at the back of the photo) that look into the vehicle sallyport and arresting officer staging area.
(Photograph courtesy of Voorhis Robertson Justice Services.)

- Pedestrian entry vestibule, which possibly includes a sobriety testing area.

Vehicle sallyport

ISSUE: A secure and protected vehicle entry for the arrestee/inmate and the transporting officer is necessary.

RESPONSE: An enclosed vehicle sallyport is the best solution to this issue as it provides three key capabilities:

- A secure environment from which the arrestee/inmate cannot escape or be aided in escape once he/she leaves the transport vehicle.
- Privacy separation from adjacent facilities or land uses and the public.
- Protection from the weather.

Although the first capability is essential, the others are highly desirable depending on location,

Exhibit 14-3. Vehicle Sallyport Showing Drive-Through Design

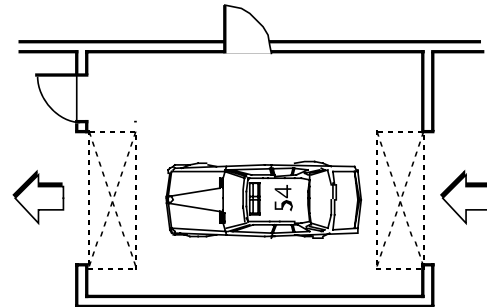

climate, and economics. Some jurisdictions, for example, only have a fenced area to provide a basic degree of security (although passage of contraband can remain a problem). This may be sufficient in cases where the jail is on a remote site, view conflicts are negligible, and the climate minimizes the need for protection from the weather. In general, it is recommended that the facility design provide a fully enclosed and securely constructed vehicle sallyport.

Following are some considerations for the design of the vehicle sallyport:

- A drive-through design for ease of operation, versatility, and traffic flow. This means a vehicle enters through one door/gate and exits through a second door/gate (exhibit 14-3).
- Sufficient height and width of doors/gates and adequate floor-to-ceiling clearance to accommodate squad cars, 4 x 4 vehicles, vans, buses, and/or emergency vehicles, including the height added by antennas, lights, and sirens and the width of ambulances and other emergency vehicles (including mirrors). Doors/gates that are 10 to 12 feet high and 12 feet wide are usually appropriate (exhibit 14-4).
- Sufficient floor area to accommodate:

Exhibit 14-4. Vehicle Sallyport Showing Floor Area Configuration

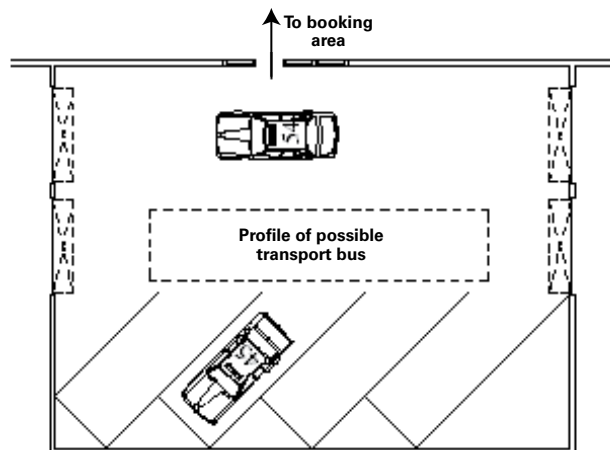

- ❑ The length of the largest vehicle that will use the space (buses are approximately 40 feet long, cars are 14 to 18 feet long).
- ❑ The width of open car doors and arrestee/inmate movement in the space (normally, a minimum of 15 feet for a sallyport that is the width of a single vehicle).
- ❑ The number of vehicles to be allowed into the sallyport at one time.
- ❑ Any parking allowed for other official vehicles in the space.
- A location adjacent to the secure vestibule entry to the jail.
- Separate storage space for any items associated with the vehicle sallyport to keep potentially dangerous items out of the reach of inmates.
- An arrangement that allows the door through which the arrestee/inmate will leave a squad car to open directly at the point of secure entry to the intake-release area.
- Sallyport doors/gates that are remotely controlled by master control to keep them easily operable and secure from tampering by inmates.
- A pedestrian entry into the vehicle sallyport from the outside, also controlled by master control, to allow officer access after parking the squad car and to allow access in the event that overhead doors are temporarily not functioning.
- An interlock for all vehicle and pedestrian doors to prevent escapes or unauthorized access.
- A radio or intercom to master control—at the entrance to the sallyport and at the entrance to the jail—to request entry and provide a means of communication from within the sallyport.
- Direct visual or CCTV monitoring inside and outside the sallyport by master control. (Direct monitoring of as much of the entry activity as possible is valuable even if not all of the sallyport can be seen without the help of CCTV.)
- Weapons lockers in the vehicle sallyport to keep handguns, Tasers, bullets, knives, and other defensive equipment outside of the intake-release area.
- Sufficient artificial lighting for nighttime use and sufficient ventilation to exhaust vehicle fumes.
- Natural light (if possible) to brighten the space and calm the arrestee, through security-glazed detention windows or skylights.
- An eyewash sink to wash out pepper spray.
- A hose bib and sloped floor drain for easy cleaning.

Pedestrian entry vestibule

ISSUE: A secure pedestrian entry vestibule may be needed to create a secure and properly controlled entry to the intake-release area.

Exhibit 14-5. Pedestrian Entry Vestibule

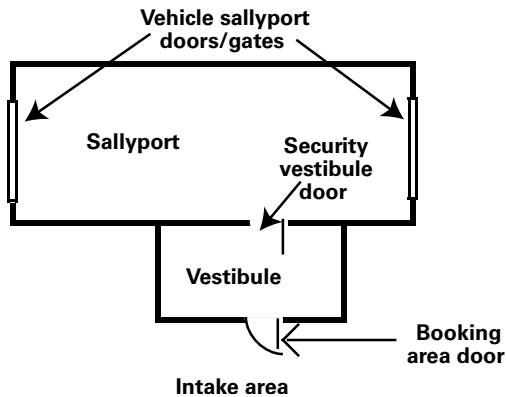

RESPONSE: A secure pedestrian entry vestibule is essential if the following conditions exist (exhibit 14-5):

- A variety of prebooking functions inappropriate for the vehicle sallyport must occur prior to allowing entry into the intake-release area, such as filling out arrest forms, securing warrants, sobriety testing, initial pat search, initial property receipt, and initial medical screening.
- There is a desire to limit the arresting officer's access to the booking area to decrease tensions by eliminating him/her from the process as quickly as possible.
- Another level of security at the point of entry, in addition to a vehicle sallyport, is desired (essentially creating three barriers between the intake-release area and the outside).

If a secure entry vestibule is required, the following design considerations apply (exhibit 14-6):

- Provide sufficient floor area to permit easy arrestee/officer flow, including difficult flow

Exhibit 14-6. Secure Pedestrian Entry Vestibule

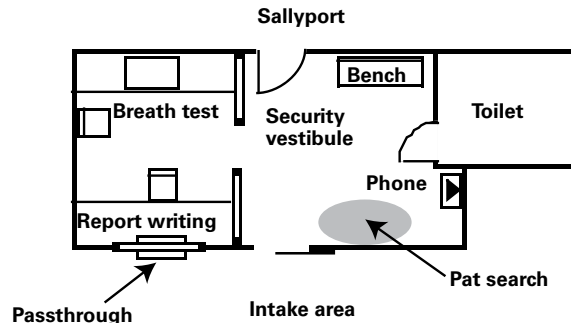

(e.g., wrestling, stumbling, fighting, two persons holding the inmate).

- Provide sufficient floor area to accommodate associated functions if the entry vestibule serves as more than just a passageway. Some possibilities include:
 - Sobriety testing (including storage for required supplies).
 - Computer workstations for arresting officers for report writing and data entry.
 - Storage for forms and property bags.
 - Toilet facilities.
 - Telephones.
 - Waiting by the arrestee (consider a bench with restraint capability).
- Provide visibility from the booking station and/or a constantly staffed post, but sufficient screening from holding areas to provide privacy for pat searches.
- Consider using sliding doors to eliminate the need for the officer to manipulate swinging doors and the arrestee at the same time.
- Interlock the vestibule doors and provide an interlock override for emergency ingress or egress.

- Provide a means of voice communication from the vestibule entry to intake-release and master control positions.
- Provide a means by which documents and property can be passed securely, such as a secure pass-through, from the vestibule to the intake-release area.
- Provide mats, nonslip surfaces, and drains to neutralize the effects of mud, snow, ice, and water brought into the area.
- Consider how larger numbers of arrestees and arresting officers can be accommodated if space is not available in the pedestrian entry vestibule.

Sobriety testing

ISSUE: Sobriety testing areas, if provided, should be affiliated with the entry sequence to limit arresting officer entry into the jail and create easy access to needed equipment.

RESPONSE: Some design considerations in regard to sobriety testing include:

- Sobriety testing should be done at or near the entry from the vehicle sallyport, preferably in an area distinct from the receiving area and accessible from the secure pedestrian entry vestibule.
- The area should be large enough to accommodate the particular type of sobriety testing equipment used; storage of testing materials, supplies, and forms; and seating for both the arrestee and the officer. (Temporary seating is important because sometimes arrestees must be observed for a 15- to 20-minute period prior to testing and may need to sit in the sobriety testing area during observation.)



A room for breathalyzer equipment on the right that is accessible from within the arresting officer vestibule between the vehicle sallyport and the intake area. The intake area is beyond the glass on the left.

(Photograph courtesy of Kimme & Associates.)

- It may be desirable to make the space large enough to conduct motor skills tests.
- Space for videotaping the sobriety and motor skills testing process may be needed.
- Toilet facilities should be provided in this area if possible because arresting officers may need to take a urine sample or intoxicated individuals frequently need to urinate and often become nauseated.

Arrestee Processing

Three functions generate space needs for preadmission arrestee processing in the intake-release area:

- Booking.
- Fingerprinting.
- Photographing.

Section 3: Functional Components

The following detailed functional-architectural issues address the design impacts of these functions.

Booking

ISSUE: The booking of an arrestee must be accommodated.

RESPONSE: The booking process is largely a paperwork and/or data entry process in which the following information is obtained about the arrestee:

- Personal data.
- Arrest data.
- Criminal history.
- Arrest authorizations.
- Medical and mental health history.
- Other relevant information.

The area primarily needs work surfaces and space around these surfaces. Smaller jails usually need only one or two booking stations because of the relatively low volume of arrests and limited staff resources. Larger jails may be designed with multiple booking stations to accommodate a larger number of bookings. Some design issues to consider include:

- Decide whether the arrestee and the intake-release officer will sit and/or stand during the booking process and ensure that booking counter surface heights correspond appropriately. Note that high chairs and stools may contribute to injuries of inmates who are intoxicated or otherwise impaired.
- Locate the booking area as close to the secure entry as possible.
- Create enough space on the inmates' side of the area to avoid congestion when others are entering and using the area.

- Identify the equipment needed and allow sufficient space for it. Equipment may include the following:

- Intercoms.
- Telephones.
- Computer terminals and printers.
- Typewriters.
- File cabinets for active inmate records.
- Forms and other miscellaneous supplies.
- Containers for temporary or secure property storage.
- A writing surface.
- Property receipt equipment, such as heat-sealing equipment for property bags.
- A clock, inmate locator board, and bulletin board.
- Electronic controls for doors, lights, and telephones.

- Decide whether the booking staff will be in an open work area or an enclosed area. Given that the intake-release officer will likely receive the inmate at the entry vestibule and move him/her through the intake-release area, an open booking area is more efficient and practical.

- Provide storage in a safe or locked drawer or cabinet for the temporary holding of cash and other valuables.
- Provide storage for the temporary holding of large property items, such as suitcases, backpacks, and attaché cases.

Photographing/Fingerprinting

ISSUE: Photographing and fingerprinting functions must be accommodated.

RESPONSE: Photographing and fingerprinting are routine functions of the booking process. The primary question in regard to planning space for this function is whether they require a separate alcove or space or whether they can be done from the booking counter. Some design considerations follow.

Photographing. Determine the method of photographing arrestees. For example:

- Digital video imaging. (This is the preferred technology for all booking photos.)
- 35 mm photographs.
- Instant-print photographs.
- Multiple instant photographs, as produced by the type of large portable machines seen in shopping centers.

The method selected will frequently depend on the needs of various law enforcement agencies outside of the sheriff's office (Federal Bureau of Investigation, state bureaus of investigation, prosecuting attorney's office) and the need to have reproducible photographs. Most new facilities now use digital video imaging techniques and equipment for routine identification purposes.

- If photographing is done from the booking counter, be sure to consider the convenience of staff in posing the inmate and returning to the camera to take the pictures.
- Provide above- and below-counter storage for equipment, supplies, and forms associated with both photographing and fingerprinting inmates. These items include booking cards, film, and development chemicals. If chemicals are used, they should be stored in a locked cabinet and should not be used in areas that are accessible to inmates.
- Provide flexibility for using a height chart as part of the photographing arrangement.



Fingerprint and photographing stations in a large booking area.
(Photograph courtesy of Voorhis Robertson Justice Services.)

(Criminal investigators may not want a height chart so they can use jail photographs for photo lineup.)

- Provide storage for the board and identification letters used in the photographing process, if they are not inserted automatically by the photographing equipment.
- Provide ample artificial lighting to enhance the quality of photographs.
- In arranging space and equipment, consider how photographs might be taken. For example, although the usual practice is to take a single shot from the front and shots from both sides of the individual, another idea is to use a mirror system that allows one shot to provide front face, left face, and right face views.

Fingerprinting. Identify the method of fingerprinting to be used. Some methods use chemicals or heat processes instead of traditional ink pads. Most modern facilities use electronic fingerprinting, which links fingerprints electronically to statewide and national databases.

Section 3: Functional Components

Make sure there is sufficient room on either side of the fingerprint pad or equipment area so that staff can stand while working with the arrestee. Provide a sink for hand washing before and after fingerprinting, a paper towel dispenser, and a waste receptacle.

Temporary waiting and holding

Because it is not always possible to immediately process every arrestee who arrives at the jail and some facilities may choose to allow arrestees to wait in the intake-release area for several hours while bond arrangements are being made, the provision of temporary holding or waiting areas is critical to the operation of the intake-release area.

All holding or waiting spaces should be easily observable from a staff post. However, care must be taken to ensure adequate privacy when toilets are included in the spaces. View conflicts between holding spaces and between holding spaces and other areas of the facility must also be controlled.

ISSUE: Secure single-occupancy holding cells should be available for arrestees or inmates who have been violent or combative or who otherwise need temporary confinement apart from other arrestees.

RESPONSE: The characteristics of a secure holding room for violent or combative inmates might include:

- A single cell of 50 to 70 square feet (check state standards for applicable requirements).
- A large security-glazed window in the cell door and/or front wall.
- Sufficient door width to allow two officers to place a combative inmate in the cell and to allow for easy entry

of a “restraint chair” and emergency equipment.

- High-security hardware.
- Detention plumbing fixtures behind a privacy screen that allows some view control (normally a height of about 40 to 42 inches is adequate). Consider installing a remote flushing feature to prevent the loss of potential evidence.
- Fixed seating (sufficiently wide and long so the inmate can lie down, if possible).
- Natural light through secure windows, skylights, or clerestories, if possible.
- Artificial lighting controlled by staff.
- At least 9-foot ceilings, if possible, to minimize random assaults on the surface or fixtures at the ceiling (e.g., smoke and heat detectors, sprinkler heads, light fixtures).
- Durable finishes and materials.

ISSUE: Multipurpose secure space is needed for holding arrestees who may not be appropriate for an open waiting area (e.g., arrestees who are under the influence of alcohol) and during staging for transport to court or to other locations.

RESPONSE: The characteristics of multipurpose holding space include:

- Multiple-occupancy holding. The recommendation is for a room that is a minimum of 60 square feet for single occupancy; 12.5 square feet should be added for each additional person the cell is designed to hold (check state standards for applicable requirements).

- Fixed seating (benches are preferred to allow seating for a number of people in the space).
- A detention-quality toilet and sink behind a privacy screen, which allows some view control by staff and some privacy for the arrestee.
- Large windows in the door and side-wall for observation from the booking/staff station in the receiving area.
- Medium- to high-security hardware.
- A floor drain.
- Nine-foot ceilings, if possible.
- Durable finishes and materials.

ISSUE: An open waiting area should be available for cooperative arrestees who are awaiting booking or pretrial release via bonding or other measures.

RESPONSE: The characteristics of open waiting areas might include:

- Fixed durable seating (such as that used in airports) in the receiving area, allowing approximately 15 square feet per seat.
- Access to a telephone.
- Access to a toilet and sink in a private space.
- Access to a drinking fountain.
- Good visibility from the booking/staff station and/or master control.
- A television and reading material, if desired, to keep arrestees occupied.
- Signs that provide information about the receiving process, bonding, legal assistance, and basic legal rights

(knowledge of this information reduces fear of the unknown and thereby has a calming effect).

- A brochure rack to provide information about alcohol/drug problems, legal assistance, and other topics, as appropriate.
- As much screening as possible from the view of individuals in holding cells.
- A location out of the main circulation path to avoid congestion and security risks.
- Natural light through secure windows, skylights, or clerestories, if possible.

Outside contact

ISSUE: Provisions must be made so arrestees can have contact with family, friends, lawyers, and bondspersons while in the receiving area.

RESPONSE: Arrestees usually have contact with outside persons in a visiting area (exhibit 14-7), video visitation booth, and/or via the telephone. In some jurisdictions it may be necessary for arrestees to have visits with family, attorneys, and/or bondspersons while they are in the receiving area. Unless

Exhibit 14-7. Visiting Area

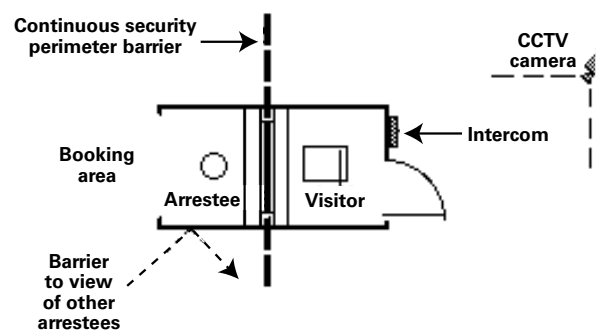

Section 3: Functional Components

a common visiting area is located next to the intake area, it may be desirable to minimize the movement of arrestees by having a visiting area for bondspersons or lawyers as part of the intake-release area. If a visitation area is provided, it should have the following characteristics:

- Visibility from a constantly staffed post or a post that is occupied during the visit.
- A controlled point of entry for the bondsperson or lawyer. This point of entry should have remotely operated locks with status indication (locked or unlocked) and it should be monitored by CCTV unless a direct line of sight to the entry can be established from a constantly staffed post without creating view conflicts with inmate areas. In addition, an intercom and camera should be located so that either master control or the booking staff can make an initial identification by voice and visual contact.
- A secure barrier between the arrestee and the visitor; the barrier should be created by using secure wall materials and security glass and framing (as discussed in chapter 18, “Visiting Areas”).
- A means by which papers requiring an arrestee’s signature can be passed securely from the lawyer or bondsperson to the arrestee. This should be accomplished with minimum staff effort. A lockable paper pass is a typical option.
- A means by which facility staff can communicate to the visitor side to respond to requests for information and to notify individuals about the end of a visit.



Booking area with open waiting (including access to a television, telephones, a clock, and restrooms).
(Photograph courtesy of Liebert & Associates.)

Telephones with outside lines should be available throughout the intake area. The primary question is how arrestees can have access to telephones within secure single- and multiple-occupancy holding cells. Several options are: (1) install wall-mounted telephones in the holding spaces, (2) move the arrestee from the cell to a central telephone location, or (3) provide a telephone jack in the walls so that a telephone unit can be passed through a food pass or opening in the holding cell door for the arrestee’s use. The choice of method depends on the visibility of the cells, the behavior expected of the individuals in the cells, the availability of staff to move inmates, and how available the facility administration wants telephone contact to be. In cases where the telephones are installed, the intake officer should have controls available to turn the phones off both individually and as a group.

In general, the most efficient use of staff time and best access for arrestees is to place telephones in holding cells, with the exception of those cells

used to house very violent or suicidal arrestees. (If the same holding cells are used to temporarily hold inmates awaiting transport to court or other facilities, a means must be available to shut off telephone access because allowing telephone calls just prior to transport violates sound security procedures.)

If the telephone will be used outside the holding cells, some level of privacy should be provided for telephone calls. A small alcove with appropriate acoustic treatments is the best solution.

Miscellaneous support

ISSUE: Miscellaneous support requirements should be accommodated.

RESPONSE: The following elements should be considered in the design of the receiving area:

- Staff toilet.
- Inmate records and files.
- General supply storage.
- Janitor's closet.
- Hose bib or hose.
- Drinking fountains.
- Clocks.
- Trash cans and wastebaskets.

Admissions Area Design

The following functional-architectural issues pertain to the admissions activities of the intake-release component; that is, they deal with the areas required for processing arrestees for housing in the facility if they cannot be released from the receiving area. The admissions area is often called the "dress in" area. These issues also pertain to the admission of inmates who are returning from court or who are being transferred from another facility.

Shower/change or "dress in"

ISSUE: Facilities should be provided so the inmate can shower and change clothing.

RESPONSE: Inmates must have a place to shower and change into facility-issued clothing before entering their assigned housing unit (assuming this is part of the facility's operational practice). The characteristics of this area might include:

- Privacy from the booking area and from the facility in general.
- Backup audio surveillance and/or communication with a constantly staffed post.
- Americans with Disabilities Act (ADA)-compliant shower, toilet, and sink fixtures.
- A drying area with a nonslip surface, a small bench, and hooks or bars to place towels and clothes.
- Excellent ventilation, especially if the area is also used for inmate decontamination.
- Shelves for prepared sets of clothing, linen, and toiletries for incoming inmates, preferably in an alcove open to the area or in a securable cabinet within the shower/change area.
- A modesty screen behind which an inmate can undress and dress when a strip search is not allowable. (In recent years considerable litigation has limited strip searches of certain arrestees, such as nonviolent felons, misdemeanants, and traffic offenders. Court rulings preclude the viewing of unclothed inmates of both genders during the search or clothing-exchange process.)

Section 3: Functional Components

- Sufficient floor area within the space to allow easy movement of at least two people and to allow the officer to conduct unclothed body searches (if applicable).
- A small work surface and form storage area to allow the officer to document the receipt of property and clothing and to obtain the inmate's signature.

Storage/issue

ISSUE: Storage, receipt, and issue of a wide variety of items must be accommodated in association with the shower and change area.

RESPONSE: There is a need to store, receive, and/or issue the following types of items in spaces adjacent to and easily accessible from the shower and change area:

- Street clothes.
- Personal property.
- Bulk property (e.g., suitcases, backpacks, duffel bags, attaché cases).



ADA-compliant shower with grab bars, a retractable seat (located behind the curtain), and dual-height shower heads. (Photograph courtesy of Voorhis Robertson Justice Services.)

- Facility-issued clothing.
- Linens.
- Mattresses and pillows.
- Toiletries.

Some of these storage capabilities might be consolidated. For example, it is common to store all inmate property (clothing, wallets, keys, suitcases) in one area that is secured from access by inmates and most staff. It is also common to consolidate linen, clothing, and toiletry storage.

Issuing methods. The extent to which items are stored near the shower and change area depends on the method of issuing items to incoming inmates and how those items are expected to arrive at the assigned cell area. For example, some facilities will issue all items to the inmate at the shower and change area, thus expecting him/her to carry them (including the bulky mattress) to the cell. Other facilities provide inmates with clothing and toiletries during the dress-in process and make sure that other essential items (i.e., a cleaned and disinfected mattress and linens) are in the cell when the inmate arrives. This distribution approach suggests that storage facilities should be located near the housing areas rather than near the admissions area.

Valuable personal property (wallets, credit cards, jewelry, etc.) may be stored in lockable drawers at the booking desk or in a space immediately adjacent to the booking desk that is accessible from the receiving area, the admissions area, and the point of release. Often, if the arrestee is housed, valuable property will be moved to a secure vault until the inmate is released. Special clothing bags with pouches that can be used for secure storage of property are also available. As noted earlier, if this approach is used, the area used to store street clothing must be secured and controlled by a few select officers to avoid loss of property.

Storage space factors. The amount of space needed for the storage of facility-issued clothing, linens, and toiletries will depend on the following factors:

- The variety of items issued by the facility.
- The method of exchanging soiled articles for clean articles. Will a full supply of linens replace those being laundered or can the same linens be removed, washed, and returned? Likewise, will all clothing need to be replaced while soiled clothing is being washed?
- The amount of additional clothing required means that proper sizes must be available for all inmates (including during periods with a high population) and that damaged goods can be taken out of circulation for repair without creating a shortage of needed articles.
- The length of time toiletry supplies are expected to last, given the facility's booking and use patterns.



Large storage room for inmate personal property in individual color-coded bags.

(Photograph courtesy of Voorhis Robertson Justice Services.)

A key functional-architectural component that is affected by decisions regarding admissions and storage requirements is the laundry, which is closely affiliated with the linen and clothing storage areas. If these areas are affiliated with the intake-release area to accommodate desired operational practices, it is critical that the laundry area be adjacent to the linen and clothing supply areas.

Release Area Design

ISSUE: The need for a separate release area should be considered.

RESPONSE: Because the receiving and admissions areas frequently serve as the release area in smaller jails, the following should be considered when developing the layout of the intake-release component (exhibit 14-8):

- The need to assemble a group of inmates to be transported or released without interfering with intake operations.
- The need to apply restraints to a group of inmates who are being transported to court, which requires a group staging area and access to restraint equipment.

Exhibit 14-8. Release Area Design

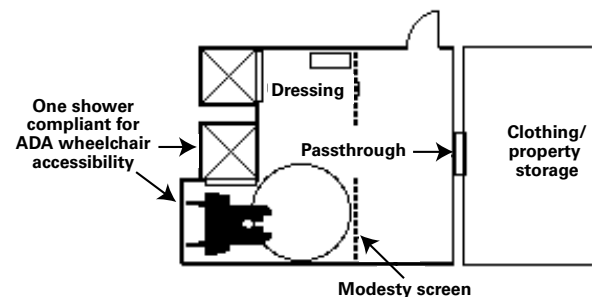

Section 3: Functional Components

- The need to change into street clothes for release or court appearances without disrupting the receiving or admission processes. A small group dressing area might be provided or the facility might require the changing of clothes at the housing units.
- The need to provide privacy for offenders when changing clothes.
- Multipurpose (multiple-occupancy) holding cells.
- Open waiting area.
- Staff toilet.
- Inmate toilet.
- Supply storage.
- Janitor closet.
- Strip search area.

Space List

Following are some typical spaces that might be found in the intake-release component.

Receiving Area

- Vehicle sallyport.
- Storage area/gun locker for the arresting officer's weapons.
- Secure entry vestibule and arresting officer work area.
- Sobriety testing room.
- Booking area storage and temporary arrestee property storage.
- Records storage.
- Booking counters for staff to process paperwork, do data entry, and interview arrestees:
 - Photograph/fingerprint area.
 - Inmate telephone alcove.
 - Secure single-occupancy holding cells.

Admissions (some storage areas might be consolidated)

- Shower/change area.
- Street clothes storage.
- Valuables storage.
- Bulk property storage.
- Facility clothing storage.
- Linen storage.
- Toiletries storage.

Local codes and ADA guidelines regarding accessibility requirements should be followed when planning these spaces.

Other related areas that may be added to the component include:

- Visiting.
- Laundry.
- Interviewing/counseling.
- Offices for pretrial personnel.

Relationships and Components

Exhibit 14-9. Relationships Between Receiving and Admissions Areas

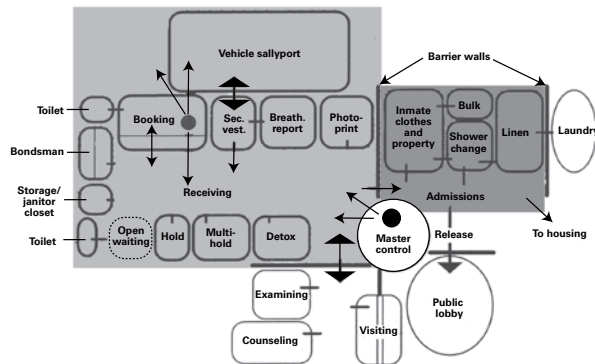
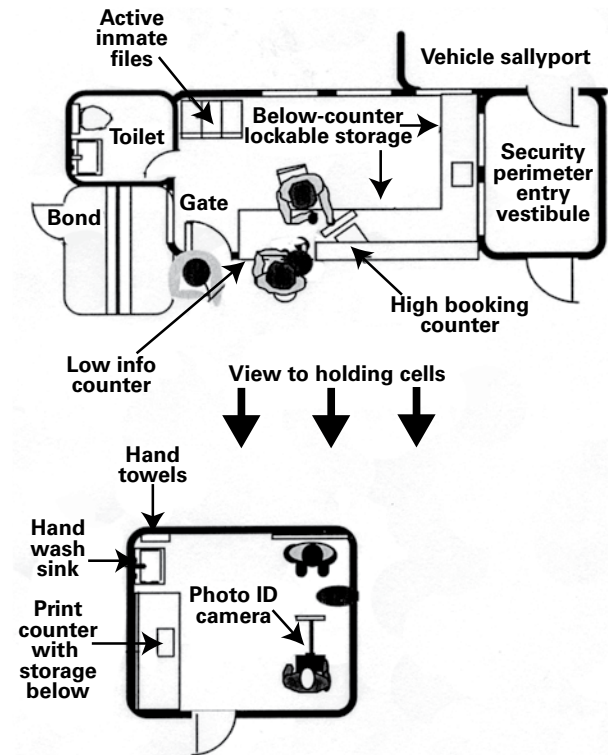

Exhibit 14-10. Components of Booking Area



Chapter 15

General Housing

The general housing component of a jail consists of those areas that accommodate the typical or “average” inmate. This inmate is defined as one who does not require special housing accommodations because of behavior, condition, or unique separation requirements. The following types of inmates are generally considered inappropriate for general housing:

- Work release/periodic-confinement inmates.
- Inmate workers.
- Protective custody inmates.
- Juveniles to be adjudicated as adults.
- Inmates requiring medical isolation.
- Disciplinary detainees.
- Suicidal inmates.
- Mentally ill (non-medication-compliant) inmates.
- Violent and predatory inmates.

Chapter 16, “Special Housing,” addresses the housing needs of the types of inmates listed above. Inmates with disabilities were historically thought to require separate special housing but can be accommodated within the general population. Their needs are described in this chapter.

The vast majority of the general housing inmate population in a facility consists of adult men in either pre- or posttrial status who have been charged with a felony, misdemeanor, municipal, or traffic offense. General housing can also contain adult women in similar categories (although in appropriately separate general housing areas). Security risk levels can vary within general housing, ranging from low to high.



Double-occupancy cells surrounding a dayroom in a linear jail.
(Photograph courtesy of Jim Rowenhorst.)

Functionally, the basic mission of general housing areas is to accommodate the sleeping, modesty, personal hygiene, personal interaction, safety, and security needs of the typical inmate and the management, safety, security, personal, and professional needs of the staff working in the area. The general housing area is the focal point of a jail design and represents a substantial portion of the costs and square footage involved with a jail. General housing areas minimally include the following types of spaces:

- Inmate cells or dormitories.
- Dayrooms (central activity areas serving a group of cells or a dormitory).
- Staff control posts.
- Security vestibules.
- Shower/toilet areas.

Section 3: Functional Components

- Miscellaneous support spaces: multipurpose rooms, storage, janitor closet, and so forth.

Historically, the inadequacies of the general (and special) housing areas have been the target of lawsuits and standards. Typical shortcomings cited about cells have included multiple occupancy and the resulting lack of personal safety when staff supervision is inadequate, limited square footage of as little as 15 square feet per inmate, and a lack of personal privacy. Courts have found artificial lighting insufficient for reading, natural light frequently lacking, and general environmental conditions substandard.

The traditional arrangement of cellblocks—principally the classic back-to-back, steel-constructed cellblocks surrounded by a barred officer corridor—has been judged to be ineffective in the proper supervision of the inmate population. Its deficiencies include limiting the officer’s view and control, providing inadequate dayroom space, offering minimal true separation capabilities, and providing severely limited sound, odor, or smoke containment capabilities.

In recent years, general housing areas have changed considerably in character. The emphasis has shifted to an improved environmental quality and improved safety. It has also shifted toward creation of a more normal environment that tends to reinforce desired behavior, express more respect for the inmate, and provide better working conditions for staff.

Direct and constant view into all parts of the housing units is increasingly emphasized. The use of modern technology to provide better security and control in support of staff efforts is increasing, and a wider variety of materials is being used instead of the traditional steel bar and plate construction.

Key Decisions

As the role of the general housing component is evaluated, the following decisions should be made because they have a fundamental effect on design requirements:

- What **classifications** of inmates will make up the general population of the jail? How will they be grouped and separated from each other? (More information is available in chapter 5, “Classification/Separation,” in section 2.)
- What **degree of flexibility** in housing unit design will be required to accommodate fluctuations in the nature of the inmate population?
- What will be the **occupancy level** of inmate sleeping areas—single occupancy, double occupancy, or multiple occupancy? (See chapter 27, “Single Versus Multiple Occupancy,” in section 4.)
- Will each housing unit have its own **dayroom**? How many inmates will use it at one time?

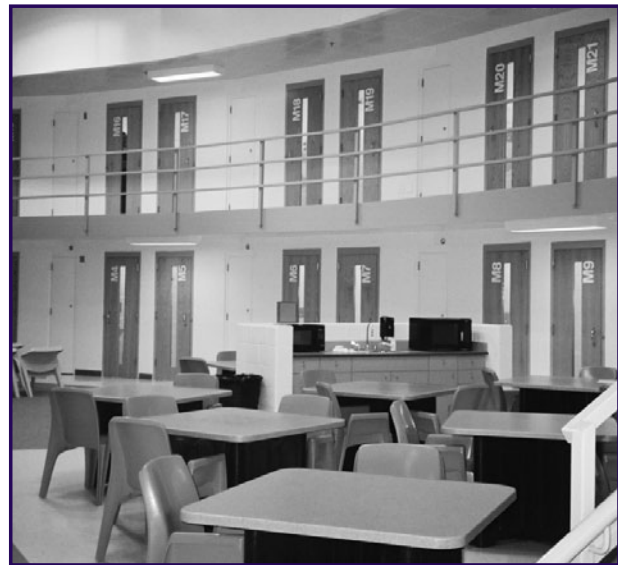

A direct supervision housing unit with wood cell doors and moveable furniture in the dayroom.

(Photograph courtesy of Voorhis Robertson Justice Services.)

How many hours per day will the dayroom be in use?

- What **surveillance or supervision** methods will be used? (See chapter 6, “Surveillance/Supervision,” in section 2.)
- What **programs and services** will be brought to the housing areas in lieu of moving inmates to the programs and services?
- How will **emergency egress** be made from the housing units?
- How will **inmates with disabilities** be accommodated, and how must housing design concepts be configured to accommodate those with disabilities?
- How will **natural light** be introduced into cells and dayrooms?
- How will **expansion** of bed capacity be achieved?

Detail Issues

The following discussion of detailed functional-architectural issues is limited to the general residential areas of the facility, including female housing areas. Housing for special groups is addressed in chapter 16, “Special Housing,” but many of the issues discussed here also apply to special housing areas. The general housing functional-architectural issues are divided into several discrete areas:

- Basic design.
- Cell design.
- Dayroom design.
- Staff control post design.
- Miscellaneous design issues:

- Security vestibule.
- Showers.
- Storage.
- Janitor closet.
- Program or multipurpose space.
- Visiting area.

Basic Design Issues

The following issues apply to the overall design of general housing units: activities, users, movement, arrangement, security, environment, fire safety, and plumbing.

Activities

ISSUE: Identify common housing unit activities.

RESPONSE: Many varied activities occur within a housing unit. Some of the more typical activities include:

- Sleeping.
- Attending to personal hygiene and grooming.
- Dressing.
- Storing personal articles.
- Talking with other inmates.
- Communicating with staff.
- Reading and writing.
- Recreating (passively and/or actively).
- Cleaning and maintaining the area.
- Eating.
- Receiving and sending mail.
- Watching television.
- Telephoning attorneys, friends, and family.

Section 3: Functional Components

The design must acknowledge the potential for less common events, including:

- Emergency communications between inmates and staff.
- Vandalism.
- Escape attempts.
- Contraband passage.
- Assaults on inmates or staff.
- Emergency evacuation.

Note: The needs of inmates with disabilities (physical, visual, auditory) must be accommodated in all routine activities and atypical events.

Users

ISSUE: The design should accommodate changes in the makeup of the average daily population.

RESPONSE: Some flexibility must be built into the design to accommodate changes in the makeup of the jail population from year to year, month to month, and even day to day. This can be achieved by:

- Subdividing a general population housing area into smaller areas so there is enough flexibility to create “swing” units that can be assigned to different general residential populations—high security or low, male or female.
- Providing security equipment and hardware that can accommodate any of the assigned groups, although this tends to make the unit higher in security orientation. Consequently, lower security populations must be distinguished from higher security populations through different management approaches.

More information on the issue of housing unit flexibility is given in chapter 5, “Classification/Separation.”

ISSUE: Providing adequate housing capacity and environments for female inmates in smaller jails presents special problems because of the small number of female inmates.



RESPONSE: Female inmates have historically represented less than 10 percent of the average daily population in a jail, although the percentage has increased in recent years. Some smaller jails do not house female inmates beyond initial booking and holding because of inadequate separation capabilities, reluctance to dedicate a housing unit to a small number of inmates, and/or the difficulties of providing same-sex staffing. Additionally, even though there are usually few female inmates, their impact on bed space needs can be significant on days when several female arrestees enter the facility.

The key to handling this population is to create one or more small swing housing units that can be used either for women or for men when not needed for women. Since this area could contain high-security inmates of either sex, it should be under constant surveillance. Providing constant surveillance also helps ensure that male staff can supervise female inmates without fear of modesty conflicts or accusations of sexual misconduct.

In facilities with a typically small female population, it is recommended that all female inmates—including those on work release or inmate worker status—be housed in the same area, although not necessarily in the same housing unit. Close supervision and management of this area will be required to ensure that inmate-to-inmate conflicts and contraband passage do not occur.

Movement

ISSUE: Identify the degree of movement between housing units and other areas of the facility.

RESPONSE: Many activities occur in a jail besides the basic housing functions. If these activities occur elsewhere in the building, inmates and staff must move to them. Another approach is to have selected activities be part of the housing area complex or to actually accommodate them within the housing units. Consequently, the manner in which programs and activities are to be accessed is a critical element of housing area design.

It is generally beneficial to minimize the amount of movement that occurs in a facility. As the security level of the inmate increases, the management benefits of limited movement also increase. The following kinds of activities have been integrated into housing unit designs to minimize inmate movement:

- Passive recreation (e.g., television (TV), table games).
- Indoor exercise (e.g., basketball, volleyball, weightlifting).
- Outdoor exercise.
- Dining.
- Counseling.
- Programs.
- Sick call.
- Visiting.
- Telephone use.
- Video arraignments.

ISSUE: Movement should be controlled.

RESPONSE: Movement within the housing units and to and from other areas of the facility should always be under staff control. To facilitate staff control of movement within the housing area, all cell, dayroom, and related housing area spaces into which inmates have access should be controlled by doors with remotely operated locking systems and keys. It is also highly desirable to have all doors in the housing unit under direct view, preferably from a constantly staffed post, as is characteristic of both direct supervision and remote surveillance designs.

Even though a remote observation or direct supervision staff post may have control over all housing unit doors, these doors should also be controllable by master control through an override function that neutralizes local control functions.



A housing unit with open dayroom, seating, showers, phones, and visiting rooms located on the mezzanine and the multipurpose room on the lower right.

(Photograph courtesy of Voorhis Robertson Justice Services.)

Section 3: Functional Components

Movement to areas outside the housing units can be controlled as follows:

- Under direct staff supervision or observation (preferred).
- Under staff observation through closed-circuit television (CCTV) monitors supplemented, as appropriate, by audio communication systems.
- By using a pass system that specifies an amount of time for an inmate to leave one point in the facility and arrive at another point, moving through areas not directly observed by staff or through areas indirectly observed by CCTV monitors.

Arrangement

ISSUE: The arrangement of housing unit spaces should facilitate control and movement.

RESPONSE: Following are several general arrangement considerations that facilitate control and movement:

- In remote surveillance housing areas, all primary spaces should be observable by staff from outside the housing unit area. These spaces include cells, dayrooms, egress doors, showers, and associated program or support areas.
- Nonhousing activities associated with the housing units must be easily accessible and within view of staff.
- Blind spots should be avoided or minimized to the greatest extent possible.
- In designs where two tiers of cells share a common dayroom:
 - The design should provide a workable view angle toward second-tier spaces, even if this requires a raised staff position (exhibit 15-1).



Open housing control booth with a good view of cell fronts, dayrooms, and mezzanine walkways.

(Photograph courtesy of Liebert & Associates.)

- Stairs providing access to the second tier should have risers that allow view through to areas behind the stair.
- Second-tier railings should allow view through to the cell faces, but be high enough (42 inches or more) to provide adequate safety for persons on the walkway.
- Walkways should be wide enough to allow easy movement where cell doors that swing out are used, but not so wide as to unduly limit view from staff positions.
- Midlevel dayrooms should not obscure views or provide hiding places at the lower-tier level.

Other considerations are discussed in section 2 and in subsequent chapters in section 3.

Some designs feature “sunken” first tiers so that access and staff positions are essentially at a second-tier level.

- Access to housing units should be through either a security vestibule or an adjacent corridor that serves as a control corridor by effectively separating the housing area from other portions of the building.
- Emergency egress routes from the housing areas should not only comply with fire codes and standards but should be easily accessible and controllable. An important element of egress that affects arrangement is the provision of two ways out of all housing areas where required (desirable everywhere).

A key aspect of creating an egress door between housing units is doing so in a manner that inhibits sound transmission and prevents contraband passage. Another consideration for egress is the possible need for, or use of, a second means of egress off the second tier of a two-tier housing unit. This implies that protected stair towers be integrated into the arrangement of the housing unit (exhibit 15-2).

Security

ISSUE: Inmates must be protected from violence, assault, and exploitation by other inmates.

RESPONSE: Following are essential considerations in designing to protect inmates from each other:

- A classification system and a range of separate housing units. (More information is available in chapter 16, “Special Housing.”)
- Selection of a mode of supervision based on careful analysis of the relative strengths, weaknesses, and efficiencies of the three most common combinations of architectural styles/supervision approaches (remote surveillance, direct supervision, and linear intermittent surveillance) and their applicability to different classifications and groups of inmates.
- Adequate numbers of qualified and trained staff.
- Choice of cell or dormitory occupancy level in conjunction with appropriate staffing to provide for inmate safety and reduce the chances of inmates being exploited, coerced, or assaulted by other inmates.

ISSUE: Differences in security and custody levels should be considered in the design of the physical environment.

RESPONSE: Even the general population of the jail consists of different behavioral

Exhibit 15-1. Unobstructed Views of Two Tiers of Cells

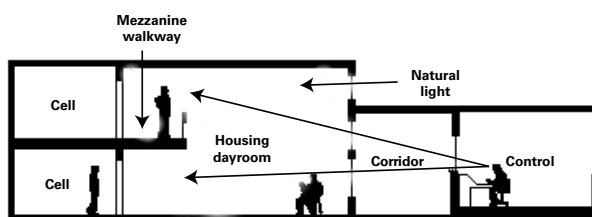
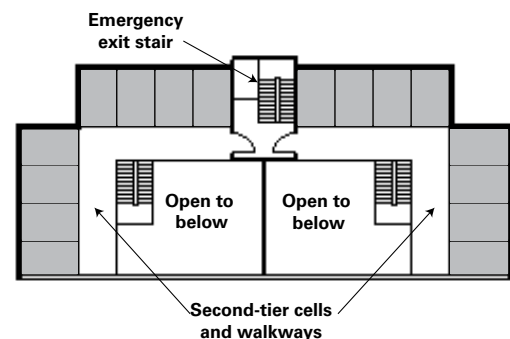

Exhibit 15-2. Emergency Exit Stair for Second-Tier Egress



Section 3: Functional Components

types, each of which poses different levels of security risk and custody needs. These can be accommodated through varying approaches to design.

The key issues that influence design revolve around classification, surveillance, and staff. In facilities that provide inadequate classification and separation capabilities and that are intermittently monitored, the physical plant must provide greater levels of security. Without constant staff control, however, it is difficult to decide what is truly “enough” physical security.

Regardless of the inmate type or the surveillance mode employed, the basic security envelope of the housing area should always be adequately constructed to prevent escape and control contraband passage. Consequently, major physical differences due to surveillance and custody level occur primarily within the housing units.

Exhibit 15-3 gives examples of some of the chief areas of difference within general population housing areas, assuming constant remote surveillance or direct supervision. These examples are not meant to describe the full range of options available, only to illustrate general differences in physical security. It is conceivable that the options under “lesser physical security” could be applied to high-security groups or vice versa. The key to security is classification, staff presence, and the surveillance/supervision approach.

ISSUE: Providing for the physical safety of staff.

RESPONSE: Physical safety of staff is an often overlooked element of housing area design. Depending on the surveillance/supervision approach used, some design considerations may include:

- Slightly raised, open counter areas in the dayroom or enclosed, secured

staff posts with solid, security-glazed partitions to allow visibility but prevent physical contact, coupled with intercoms or speaker boxes for communication.

- Direct visual backup of staff entering or working around housing units.
- Body alarms, radios, and/or panic alarms linked to secured, constantly staffed posts such as master control.
- CCTV and audio backup from inside the housing area to master control.
- Design of locking systems to minimize escape potential if a roving officer or the housing area control officer is assaulted by inmates (e.g., all locks remotely operated so that the roving officer has no keys, or keys only to immediate areas such as cells and closets, but no exit keys).
- Secured openings (passthroughs) through which items exchanged between staff and inmates (e.g., food, drinks, clothing, linens, mail, packages, and paperwork such as sick call requests and commissary slips) can be passed without entry into the housing unit (this should only be considered in the highest security housing areas where the likelihood of staff assault is great).

Environment

ISSUE: The need or desire for natural light in housing areas should be balanced against security concerns.

RESPONSE: All inmate cells and dayrooms should have exposure to natural light. Natural light is valuable in that it contributes to good physical and mental health and to a

Exhibit 15-3. Examples of Variations in Design Approach

Design element	Greater physical security	Lesser physical security
View to exterior	To controlled exterior space or not provided	To outside
Access to adjacent program areas	Controlled at all times	Free movement at some or all times
Entry vestibules	Yes	No
Floor	Concrete, terrazzo	Carpet on secure base, vinyl composite tile
Interior cell partitions	Concrete; reinforced, grouted concrete masonry unit, modular construction	Concrete masonry unit, cement plaster on metal lath
Cell ceilings	Concrete	Cement plaster on metal lath, acoustic metal
Dayroom ceilings	Concrete, cement plaster on metal lath, steel panels	Acoustic tile or panels, two layers of gypsum board (assuming adequate ceiling height and dayroom perimeter secured by other means)
Interior dayroom/cell face glazing	Glass-clad polycarbonate or equal	Laminates of strengthened glass, tempered glass
Furnishings	Fixed detention type	Nonfixed institutional or commercial
Cell doors reinforced	12- or 14-gauge steel	14- or 16-gauge steel or solid-core wood
Cell locks	High-security remotely operated	Low-security detention or heavy-grade commercial remotely operated (durability is the issue)
Plumbing fixtures	Stainless steel combo sink/toilet, stainless steel shower cabinet	Vitreous china sink and toilet, concrete masonry unit shower with sealer, and premade base
Light fixtures	Detention type	Detention type, some inmate control in cells

Section 3: Functional Components

more normal-appearing environment that encourages or reinforces more normal behavior. Providing natural light, however, also poses potential security or management problems:

- Escape.
- Passage of contraband.
- Vandalism.
- View conflicts with persons outside the facility.
- View conflicts between housing units.

The greatest problems occur with cell windows to the exterior of the facility because cells are generally a less observable part of the housing area and penetration of the window can result in penetration of the main security envelope.

Cell window design can help mitigate escape, contraband passage, and vandalism problems. View conflicts with cells and dayrooms can be controlled by:

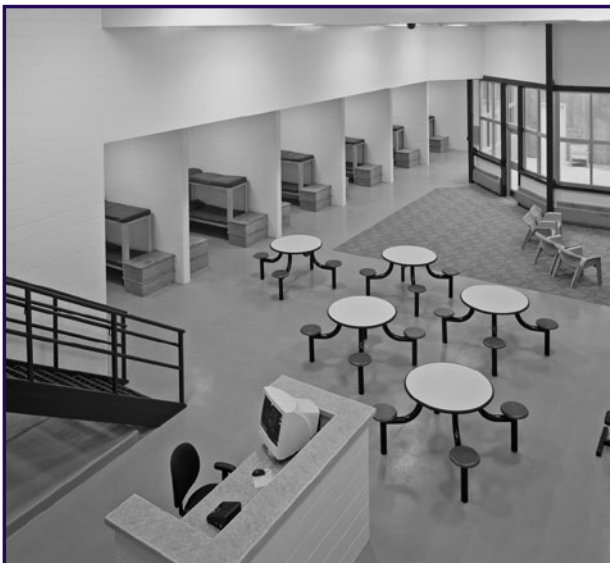

Minimum security housing unit with open dorm sleeping areas and open access to outdoor recreation yard.

(Photograph courtesy of Voorhis Robertson Justice Services.)

- Orienting windows toward interior courtyards or screened areas.
- Placing windows high in the wall (exhibit 15-4).
- Using reflective or heavily smoked glazing products to limit view, especially during daylight hours. Use of translucent, rather than transparent, glass products allows in light but obscures the view to the outside.

One way to minimize window security problems is to introduce borrowed light to the cells from other spaces rather than provide an exterior window in each cell. Historically, this was done by placing cells on the interior of the housing area (typically back-to-back with other cells, divided by a chase) and separating them from windows by a dayroom and a perimeter corridor. An aesthetic value to this was that the dayroom—the place where inmates spend the majority of their daytime hours—received the most natural light.

A common problem with this approach was that the windows were typically limited in size and heavily screened to minimize escape potential and eliminate view conflicts. Consequently, limited amounts of light were afforded to the occupants of the cells. It also tended to negate remote observation possibilities in which a full view of cell fronts and some portions of the cell interiors were provided from a point outside the housing unit.

Exhibit 15-4. Use of High, Small Windows and Skylights

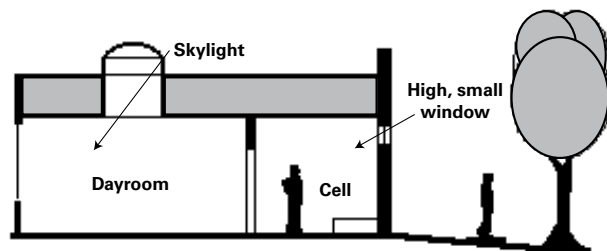
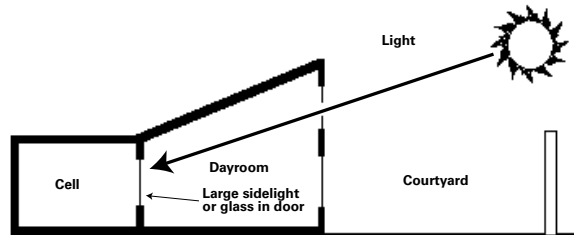

Exhibit 15-5. Use of Clerestory Window To Introduce Light Into Interior Cells



A variation on the borrowed light concept for remote observation housing designs is to use clerestories, skylights, and adjacent outdoor areas to introduce natural light in significant quantities instead of using exterior cell windows (exhibit 15-5).

Even then, the amount of light actually entering the cells would still be limited; especially if modesty demands meant that the cell face (walls and door) was largely solid.

To introduce natural light directly into cells but fully eliminate view conflicts, some facilities employ translucent or obscured glazing, thereby sacrificing all view. This tends to occur most often with ground-level cells on restricted urban sites where the possibilities for controlled exterior areas are limited.

If natural light is provided in the dayroom via a window or clerestory, it is preferable that the light not shine directly toward the officer inside or outside the housing unit. Otherwise, the glare from the light source could increase eye strain, reduce effective view control, and cause glare, making it difficult to read computer screens. If the window or clerestory is out of the officer's view, it should also be inaccessible to inmates.

ISSUE: Basic environmental needs should be accommodated.



Natural light brought into a housing area through a wall of windows to an outdoor exercise area.

(Photograph courtesy of Voorhis Robertson Justice Services.)

RESPONSE: The environmental quality of housing areas can make them more livable and influence inmate behavior. Cooperative, calm behavior is not reinforced by noisy, cold, dark areas thick with unpleasant odors. Most state jail standards and building codes require basic environmental quality. Some special considerations for jail housing areas include sound, artificial light, and temperature.

Sound. Sound quality is one of the more difficult environmental problems, resulting from the typically hard surfaces and many sources of sound, for example:

- Electric locks (solenoid and motorized).
- Slamming doors, sliding doors.
- Inmate voices.
- Electronic communications (intercoms, public address).

Section 3: Functional Components

- Showers.
- Toilets.
- TVs and radios.

These frequently combine to produce high sound levels and, with hard surfaces, generate reverberations (echoes) that can obscure conversation and be irritating to both inmates and staff.

Following are some solutions to the problem of sound:

- More textured surfaces (e.g., concrete masonry units—versus concrete or steel plate—acoustic ceiling panels, carpet on floors or selected wall surfaces).
- More irregular surfaces (e.g., angled walls, pan joist structural systems).¹
- Solid cell and dayroom faces (e.g., block, hollow metal or solid wood doors, security glazing) instead of bars or grating.
- Quieter locks (e.g., electric motor or pneumatic versus solenoid).
- Swing doors instead of sliding doors.
- Showers pocketed within the walls of the dayroom rather than steel shower cabinets in and facing the dayroom.
- TVs with localized speakers controlled by staff rather than inmates, or TVs that can be heard only with headsets purchased by the inmates or provided to indigent inmates.
- Separate TV-watching rooms adjacent to, and viewable from, the dayroom.

Artificial light. Historically, artificial light has been a problem because of its insufficiency in providing adequate lighting and because of its constancy. The latter frequently results in vandalized fixtures when inmates get no relief from light at night. Some solutions:

- Provide night lighting capabilities in cells and dayrooms that allow primary lighting to be shut off.
- Provide selected categories of inmates some control over their cell lighting.
- Avoid light sources that shine toward the jail officer looking into the area.
- Avoid using lighting with unnatural light spectrums, such as high-pressure sodium fixtures that are energy efficient but more suitable to street lighting because of their yellowish color.
- Provide staff with control of the lighting in their spaces, adjacent housing area corridors, and housing units, for good vision and reduced eye strain.

Temperature. Complaints about temperature most frequently relate to that in cells. This is because cells are often made of hard, cold surfaces; do not have individual temperature control; and are on an exterior wall. In addition, their heat source is normally at the front of the cell, the opposite of typical building practice. The design process should evaluate ways to get the heat to the outside wall and at the floor in a vandal-resistant manner.

¹ Pan joist construction refers to a one-way structural system using a ribbed slab formed with pans. The system achieves economy through the reuse of standard forming pans. Special design provisions for pan joists have been established through many years of construction experience. Standard pan forms produce dimensions of 20 or 30 inches, and depths range from 6 to 20 inches, although other sizes are available. Spans normally range from 15 to 50 feet, but may be extended by post-tensioning. Joists may have openings in the ribs to accommodate mechanical systems. Slabs between the joists can readily accommodate duct openings or sleeves.

Fire safety

ISSUE: Fire safety is a critical consideration in the design of housing areas.

RESPONSE: Most injuries and deaths resulting from fire or smoke inhalation in jails occur in the housing areas. The National Fire Protection Association's *Life Safety Code*[®] specifically addresses jail safety issues.² It is strongly recommended that planners refer to the *Life Safety Code*[®], conduct a thorough review of local codes, and consult with fire inspection officials early in the design process.

There are several special issues to consider besides providing proper means of egress and proper detection, alarm, and suppression systems:

- Using fire-retardant, nontoxic materials wherever possible and consistent with general design/environmental goals.
- Providing a place to store extinguishers and airpicks that is easily accessible to all staff positions.
- Providing backup keys in a secure area outside the jail perimeter.
- Providing emergency group unlocking capabilities in all housing units, with master control override.
- Developing fire zones within the facility perimeter to prevent emergency release from the building being the only option (exhibit 15-6). Creating an outdoor retention yard that might also serve as the outdoor exercise area is also worth considering.
- Avoiding open, barred, or grilled cell and day-room fronts, which are incapable of providing any fire or smoke containment.

- Consulting local fire inspectors on the use of security glass and passthrough openings in housing unit dayroom walls, which frequently abut egress corridors, thereby potentially conflicting with fire ratings for those walls. Variances may have to be sought on the basis of security need and be justified by the provision of a full range of detection, alarm, suppression, and evacuation measures.
- Creating a “no smoking” facility or limiting smoking to specified areas in jails where smoking is still allowed.
- Installing built-in electric cigarette lighters for inmate use to eliminate the need for matches and lighters in inmate-occupied areas.
- Using flame-retardant, nontoxic mattresses and pillows.
- Considering how firefighters will gain access to various parts of the building.

Plumbing

ISSUE: The need for plumbing fixtures depends on the operation of the housing unit.

RESPONSE: It is generally accepted, and required by most standards, that all cells and

Exhibit 15-6. Fire Zones

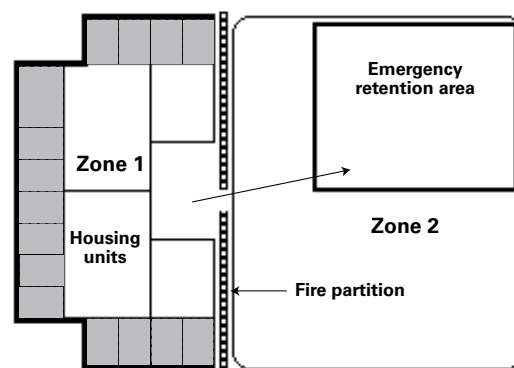

² National Fire Protection Association, *NFPA 101®: Life Safety Code*[®] (Quincy, MA: National Fire Protection Association, 2009).

Section 3: Functional Components

dayrooms have toilet and sink facilities. However, the key issue regarding their location is one of access.

Individual cells generally have toilet and sink fixtures because there is an expectation that inmates will be locked in their cells at night and have no alternative bathroom facilities. However, in constantly monitored areas backed up by roving officers (especially direct supervision areas), it is possible that inmates could use centralized facilities at night. This seems feasible because inmates use centralized facilities and/or cell facilities without incident during the day, when many more activities and distractions are occurring.

Having centralized facilities rather than in-cell facilities (thereby creating “dry cells”) does not necessarily preclude the ability to lock down inmates during disturbances or inspections, because inmates can be individually released through remotely controlled cell-locking mechanisms. Also, additional staff are typically assigned to the facility during disturbances and inspections to provide necessary security support and thus offset potential problems.

Toilet and sink fixtures accessible from the dayroom are required when the operation of the housing unit includes denying inmates access to their cells for significant portions of the day (or when there are no fixtures in the cells). If such an operational approach is not, and never will be, adopted, toilet and sink fixtures in the dayroom are merely a convenience.

ISSUE: The design must accommodate potential problems with damaged or inoperable plumbing fixtures.

RESPONSE: Some issues to consider follow.

- Providing floor drains to accommodate accidental or purposeful spillage from

fixtures in cells or dayrooms. Drains should be placed outside cells to minimize inmate attempts to block them.

- Making pipe chases readily accessible to maintenance staff and sufficiently large to allow easy repair.
- Locating shutoff valves strategically to allow staff to stop water flow in specific areas. One such location might be a secure space accessible from outside of the building to provide some level of control in the event that inmates take over the jail. This can also be accomplished through the use of electronic controls in master control, at the officer’s desk, or at the housing control station.

Sleeping Area Design Issues

The following functional-architectural issues apply to inmate sleeping areas, both cells and dormitories: occupancy, size, activities, equipment, psychological needs, and security and privacy.

Occupancy

ISSUE: The occupancy of sleeping areas in a facility is determined by the agency’s philosophy and approach to surveillance/supervision; by inmate behavior, classification, and custody levels; and by construction costs.

RESPONSE: Perhaps the most significant decision regarding the design and operation of a new jail is that of sleeping area occupancy. This choice measurably affects initial construction costs and significantly affects long-term operations and staffing. The options available to a jurisdiction generally include single-occupancy cells, double-occupancy cells, and multiple-occupancy cells (three or more inmates).

The word “cell” has classically been applied to inmate sleeping areas of one to eight beds that are separate from an inmate dayroom in which showers, dining/recreation tables, and TVs are located. The word “dormitory” is generally applied when sleeping and dayroom functions are merged together or when the sleeping room occupancy reaches nine or more, even if there is an adjacent dayroom.

The principal argument for using double- or multiple-occupancy cells is construction cost savings. The arguments against them, as compared with single-occupancy cells, are as follows:

- Less ability to ensure inmate safety from physical or sexual assault.
- Inability to isolate inmates during fights or disturbances.
- Greater demand for maintaining a constant staff presence during sleeping hours, whereas with single-occupancy cells, inmates can be locked down at night and checked intermittently by roving staff.
- More difficulty in protecting inmate property from theft.
- Less accountability for cell/dormitory damage and vandalism.
- Elimination of an inmate’s principal source of privacy.

The debate over single- versus multiple-occupancy cells most typically occurs when making housing design decisions for the general inmate population. This is because most of the special housing populations discussed in chapter 16 are more clearly either single-occupancy candidates (disciplinary detention, medical isolation) or multiple-occupancy candidates (inmate worker, work-release inmate).

The challenge to most jurisdictions is to determine whether initial cost advantages during construction justify potentially greater operational and staff cost challenges over the operational life of the building. For more on this subject, see chapter 27, “Single Versus Multiple Occupancy,” in section 4.

Size

ISSUE: Sleeping area size is shaped by activities, equipment, and individual needs.

RESPONSE: American Correctional Association (ACA) standards and some state standards require a minimum square footage for sleeping areas. These requirements are not uniform and often vary according to the occupancy level of the sleeping area. Sleeping area size is also influenced by the amount of time an inmate is confined to the area per day. Cell size should be based on the activities to occur in the cell and the type of furnishings and equipment selected for use.

Activities

Activities that might influence cell size include the following:

- Sleeping.
- Reading and writing.
- Grooming.
- Storing personal belongings and toiletries.
- Using the toilet.
- Doing limited calisthenics (e.g., pushups, situps).
- Eating (not recommended for general population cells).

Equipment

Equipment options that can influence cell size include:

Section 3: Functional Components

- **Bed size.** Beds sufficient in length and width to accommodate taller, heavier people may dictate special designs that exceed the approximate dimensions of the standard detention bunk (approximately 80 by 27 inches).
- **Bed arrangement.** Bunk beds used in multiple-occupancy settings demand less floor area than separate beds.
- **Desk surface.** Minimal desk surfaces, as offered by detention equipment manufacturers, provide approximately 2 to 4 square feet. If more desk surface area is needed, a fabricated surface may provide more square footage and thus require more area in the cell. Smaller detention desks with angular wall supports are not recommended if the angle interferes with desk use.
- **Seating.** Desks are frequently accompanied by a fixed or moveable stool or chair. If fixed, an established area of the floor is committed. Swing-out stools are available on some detention desks, and some designs allow the bunk to serve as the seat.
- **Storage.** Storage for toiletries, books, paper, pens, pictures, clothing, and so forth is essential to maintaining a neat and sanitary cell environment. Shelves and collapsible hooks create no special space demand, whereas lockers or storage drawers do demand floor area.
- **Plumbing fixtures.** A toilet and sink occupy square footage. Besides the possibility of a pipe chase intrusion (which is typically outside of cell square footage requirements as defined by standards), the key space-defining issue is whether a combination toilet/sink or more normal, but space-occupying, separate fixtures will be used (exhibit 15-7).

Providing a partial-height privacy wall or splash screen between the fixtures and the bed may also require slightly more space.

Showers are typically not placed in general population cells because of expense, sanitation complications, and security. Consequently, no space is typically needed for showers.

Psychological needs

Psychological needs involve the sense of confinement created by the cell space in particular. These concerns and the need for more space as compensation can be minimized by:

- “Extending” the sense of space through the use of sizable cell windows in the face of the cell (without sacrificing minimum privacy or security).
- Using ceiling heights moderately higher than the typical 8 feet, which also has the advantage of allowing ceiling sprinklers and light fixtures to be placed at less accessible heights, thus reducing the potential for vandalism.
- Avoiding unusually narrow cells that disproportionately accentuate room length.
- Using light colors for walls and ceiling.

Security and privacy

ISSUE: Regardless of the classification of inmates, all sleeping areas must be designed with security in mind.

Exhibit 15-7. Comparison of Space Needed for Combination Fixture Versus Separate Toilet and Sink

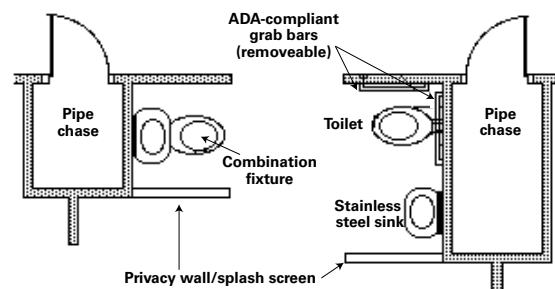

RESPONSE: Cells and dormitories are places where inmates spend a significant portion of their day. They are frequently located on exterior walls at points in the housing unit farthest from view (as in the case of remote observation or direct supervision) or even out of the view of staff standing in or moving through adjacent corridors (as in the case of traditional linear intermittent surveillance). Consequently, cells and dormitories provide the best opportunities for escape attempts, vandalism, suicide attempts, and/or contraband passage. A variety of considerations can help minimize these problems:

- Paying particular attention to the security design of the sleeping area exterior window, if used. (The topic of security glass is addressed further in chapter 28, “Renovating Nonsecure Buildings Into Jails,” in section 4.)
- Ensuring that the exterior wall is of secure construction, if the cell is on an exterior wall. If a concrete masonry unit wall is used, the wall should be reinforced and grouted.
- Using sturdy and vandal-resistant materials within cells. Such materials as concrete or vinyl tile on concrete floors, concrete masonry units for walls, and concrete or cement plaster for ceilings are appropriate. However, security in this instance does not imply that the space need be dark or grim. Modular concrete and steel cells are constructed of secure materials (although issues of poor acoustics must be considered).
- Securely fastening in place all miscellaneous equipment and hardware in the cell or dormitory (e.g., outlet

covers, intercom covers, vent grills, mirrors, shelves, clothing hooks, door stops).

- Minimizing the size of vent grills and using a security grill that makes it difficult to tie a string or string-like object through the grill to attempt suicide.
- Avoiding joints and gaps that can be used to hide contraband in places that cannot be easily checked by staff.
- Minimizing, to the greatest degree possible, the potential for suicide in the selection and design of furniture and equipment.

ISSUE: A balance must be struck between inmate privacy in the single-occupancy cell and the need to observe the cell.

RESPONSE: A key element of guaranteeing a degree of modesty is to create single-occupancy cells. Single-occupancy cells (in association with a dayroom to prevent isolation) tend to enhance rather than diminish security, as has been noted above.

The primary conflict between privacy and security comes in deciding how much of the face of the cell to expose to the dayroom and thereby to staff in the adjacent corridor or control position (exhibit 15-8). The options range from precluding any view of the cell to opening up the entire face of the cell (the classic approach to cell design). However, if any balance between modesty and security is to be attained, the proper approach falls somewhere in between.

The main privacy concern that guides the choice of cell front design is exposure of the inmate using the toilet to both inmates and staff passing the cell, particularly those of the opposite sex.

Section 3: Functional Components



Cell fronts with large windows. Note that the bottom half of the windows are frosted for privacy in the cell.
(Photograph courtesy of Voorhis Robertson Justice Services.)

This is a special problem in cells designed with fixtures toward the front of the cell, where they cannot be internally screened. Locating the toilet at the rear of the cell has an advantage in this regard because partial-height screens (about 44 inches high) can provide minimal privacy while allowing a view capability and a more liberal opening of the cell face.

Two other cell modesty concerns involve minimizing inmate exposure while sleeping and dressing. Related to those concerns is a simple environmental concern of minimizing the transference of light between the dayroom and cells during evening and sleeping hours.

Regarding security, the issue of needed exposure depends on the classification of the inmates involved and on the method used for observing and managing the inmates while they are in their cells. Staff should frequently enter the housing unit to closely examine the cells and check on the welfare of the inmates in the cells. In this

Exhibit 15-8. Options for Exposure of the Face of the Cell

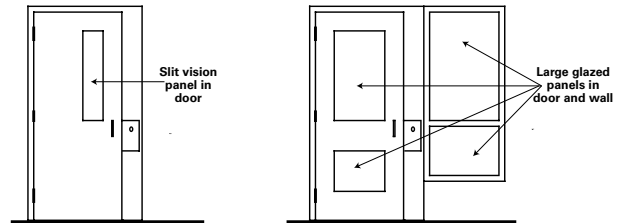

case, exposure of the cell interior to remote view becomes far less critical.

One additional modesty concern involves the (indecent) exposure of inmates through exterior cell or housing area windows. Besides the view conflicts involved from the public's side, the inmates' modesty is infringed when the public can readily see into cells from the street or adjacent buildings.

ISSUE: Some semblance of modesty should be achieved in multiple-occupancy settings.

RESPONSE: The very nature of multiple-occupancy housing precludes fundamental modesty in these settings. However, minimal levels of privacy can be obtained by providing:

- A modesty or splash screen between toilet areas and the bed and desk areas of the cell or dorm.
- Privacy partitioning that creates small groups of beds (two to four) in large dormitory settings.
- Separate shelving or lockable storage compartments for each inmate.
- Study or reading carrels or alcoves in adjacent dayrooms.

Dayroom Design Issues

The functional-architectural issues that apply to dayroom areas—the central activity areas around which a group of cells is clustered to create a cohesive housing unit—are location and size.

Location

ISSUE: Dayrooms should be located to ensure ease of inmate access and to preserve separation capabilities.

RESPONSE: Dayrooms should be located adjacent to and immediately accessible from the cells or dormitories they serve. There should be one dayroom for each group of cells. Such design minimizes inmate movement and eliminates the security problems posed by the shared use of a dayroom by different classifications of inmates and by dayrooms separated from the housing units.

Size

ISSUE: The size of dayrooms is dictated by the activities to occur there, functionality, and aesthetic concerns for proportion.

RESPONSE: ACA standards require that dayrooms provide certain square footages. Most often, these square footages are based on the number of beds in the housing unit served by the dayroom. In some standards, the square footage is defined by the maximum number of inmates using the dayroom at one time. In the latter case, decreasing the dayroom square footage by reducing the number of inmates allowed access to the dayroom at one time may be offset by increasing the cell size requirements, because inmates are confined there for a greater part of the day.

In small housing units, typical dayroom square footage requirements can result in little more

than a narrow 5- to 6-foot corridor along the front of the cells. In most cases, this is not satisfactory, given the kinds of activities desired for this space; the simple functionality of moving through, living in, and working in the space; and the desire for a well-proportioned room.

The actual size of a dayroom should depend on a variety of practical design considerations. Activities that might occur in the dayroom and therefore help define its size requirements include:

- Eating meals and snacking.
- Reading and writing.
- Conversing.
- TV watching.
- Telephoning.
- Exercising (e.g., calisthenics, weights).
- Engaging in passive recreation (e.g., table games).

Some activities that take place as part of the overall housing unit should not occur in the dayroom unless all inmates in the housing unit are involved in the activity (e.g., counseling, religious services, and other group program activities). Some of the more personal individual activities, such as visiting, individual counseling, and medical checkups, should not occur in the dayroom unless the housing area has been designed with dedicated space for those functions (e.g., medical exam room, multipurpose room, or counseling office).

Tables and seating provided for inmates are another key determinant of dayroom size. Most standards, and good practice, require sufficient tables and seating to accommodate every inmate housed in the unit, including those who are wheelchair bound. This is particularly critical if dining occurs in the dayroom. Additionally,

Section 3: Functional Components

sufficient space to move around the tables and seating to gain access to exits, cells, and activity areas is crucial.

The question of table placement becomes more critical when two-tier housing units are created. One of the basic ideas behind two-tier units is to reduce the need for excess dayroom space. However, in a housing unit with limited capacity, the intrusion of the stairs to the second tier can unacceptably diminish the workability of the dayroom layout (exhibit 15-9). This is truer when a security vestibule and a shower area also intrude into the dayroom.

Another size consideration concerns temporary activities that occur in the dayroom. One example would be the extra space needed at meal time for food carts, trays, and meal distribution in each dayroom.

Pieces of equipment (e.g., TVs, telephones, service counters) and their placement also influence the size of the dayroom. Some of these items need to be separated from each other and from other functions in the dayroom. For example, telephones should be located as far as possible from the TV and other noise sources, and TVs should be positioned to provide proper viewing angles. To achieve this, the TV cannot be placed too high on the wall, and there should be some distance between it and the nearest table. However, TVs should not be placed so low that they obstruct movement or officer view of the area.

Miscellaneous Furniture and Equipment

ISSUE: Miscellaneous furniture and equipment should be identified for proper placement in the dayrooms.

RESPONSE: Besides the tables and chairs used by inmates and major items such as TVs and telephones, several other types of equipment must be accommodated in the dayroom:

Exhibit 15-9. Configuration of Dayroom in Two-Tiered Housing Unit

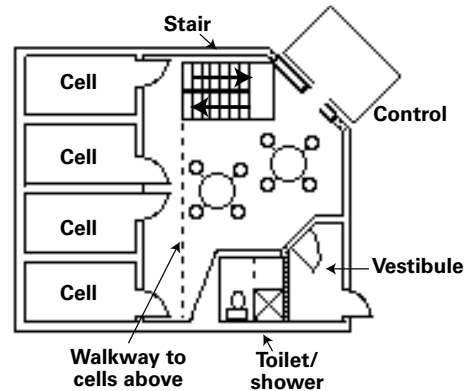

- Officer's work area, in direct supervision housing units.
- Waste containers.
- Bulletin boards for notices and information.
- Intercoms for communication with staff in remote surveillance housing.
- CCTV cameras, as appropriate.
- Recreational equipment.
- Library carts.

Inmates With Disabilities

ISSUE: The needs of nonambulatory, wheelchair-bound inmates must be accommodated in housing units.

RESPONSE: If the facility is to hold nonambulatory, wheelchair-bound inmates, certain special requirements must be met in their housing units and throughout the facility.

Inmates with disabilities share all of the behavioral and custodial characteristics of other inmates, and housing units must be designed to accommodate them at different custody levels.



Specially designed toilet and sink combination unit with grab bars for use by inmates with disabilities.
(Photograph courtesy of Liebert & Associates.)

The law prohibits housing inmates with disabilities according to their disability alone, for example, in a housing unit designed to accommodate all inmates with disabilities or an isolated “disabled cell.” This is a significant consideration because it means that most, if not all, housing units must be designed to accommodate the needs of those with disabilities. This is true even if the number of such inmates detained in the course of a week, month, or even a year, is quite low.

The most common housing area design challenge comes with respect to inmates confined to wheelchairs. Local, state, and federal codes and standards in this regard must be researched prior to design. Special design considerations include the following:

- All doors leading to the housing area and Americans with Disabilities Act (ADA)-compliant cells must be wide enough to allow the passage of a wheelchair. Additionally, sufficient room must be allowed on the latch side

of doors, especially when they swing toward the user, to allow access, opening, and maneuvering room.

- If staff are not in a position to assist the inmate, door closers should not be set at a tension level that makes opening by the disabled inmate difficult.
- Toilet and sink fixtures in the cell should be separate fixtures that accommodate the needs of the disabled inmate or specially designed combination fixtures. Grab bars or a means by which the inmate can access toilet fixtures should be provided. If grab bars are used, consider making them demountable using special tools so they do not pose a security problem with inmates without disabilities who might use the cell. Grab bar design should preclude suicide attempts.
- Central shower areas and toilet areas should be accessible to inmates with disabilities.
- Cell desks and a position at the dayroom tables should be accessible to the inmates with disabilities. This implies that the use of a fixed stool may be inappropriate in the cell and that at least one position at the dayroom tables should be either a moveable chair or a swing-out security seat (exhibit 15-10).

Exhibit 15-10. Dayroom Table With Swing-Out Seat To Accommodate Wheelchair

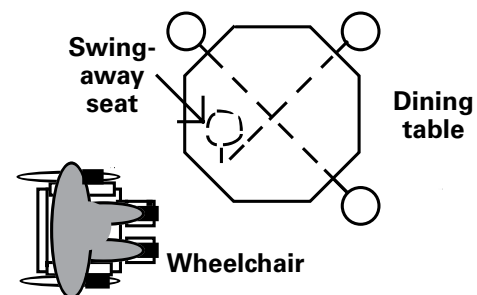

Section 3: Functional Components

- Features in the dayroom or housing area, such as intercoms, telephones, and drinking fountains, should be accessible to a wheelchair-bound inmate.
- Ramps at points of entry/egress to the building should be considered (e.g., main entry, sallyport, exercise areas).
- All program and service areas should be accessible to inmates with disabilities.

ISSUE: Forms of disability other than being non-ambulatory and wheelchair bound must be accommodated.

RESPONSE: When most people think of inmates with disabilities, they think exclusively of people who are wheelchair bound. The ADA, however, identifies many other conditions that are considered disabilities, and these should be considered in the design and operation of new jail facilities. Two examples of disabilities with an impact on facility development are auditory and visual impairments.

Auditory impairments

Many modern jails rely on auditory-based electronic communications (intercoms, public address systems, telephone visiting, fire alarms, television monitors). Communication with hearing-impaired inmates can be lost unless special steps are taken in the selection of equipment and/or establishment of operational policy intended to provide equal access to hearing-impaired inmates. Several physical plant features can be incorporated that respond to daily and life safety needs in housing areas:

- Telecommunications Device for the Deaf (TDD)-style telephones for telephone calls and telephone visiting, such as video visiting, in most, if not all, dayrooms.

- Fire alarm systems with visual effects (e.g., flashing lights), as well as audio systems that can be “felt” through sonic vibrations.
- TV monitors with closed caption capabilities.
- Orientation tapes that convey facility rules through presenters who sign, as well as with closed captioning.
- Electronic message boards within view of cells and dayrooms that can be used to convey routine messages (e.g., visiting hours) as well as information usually expressed orally.

Visual impairments

Facility development considerations with respect to inmates with visual impairments are:

- Braille signage on cell doors and throughout the facility.
- Posted Braille version of key facility rules and policies.
- Cell and especially dayroom areas sufficiently spacious to allow easy, clear paths of travel around furniture and equipment and to emergency egress routes.
- Issuance of canes approved by facility administration.
- Location of cells designed for those with disabilities near shower/toilet areas and egress routes.

Staff Control Post Design

The following issues pertain to staff posts that observe or supervise housing units: post size, staff activities, and mode of surveillance/supervision; shape of post; security; and communications.

Size, activities, surveillance/supervision mode

ISSUE: The size of staff control posts depends on staff activities and the surveillance/supervision mode used.

RESPONSE: Staff members in charge of observing and supervising housing units have a variety of responsibilities, which typically include the following:

- Observing and supervising inmates.
- Report writing.
- Recordkeeping, activity logging.
- Storing and maintaining manuals, directories, and similar materials.
- Responding to inmate complaints and needs.
- Communicating with other staff in the facility via intercoms or telephones.
- Observing and controlling activities in and around the housing units (e.g., food service, laundry pickup, counseling, movement to court or visiting, maintenance).
- Monitoring alarms and other security systems.
- Responding to emergency situations.
- Controlling doors, lights, heat, ventilation, communications, and/or security systems within the housing unit.
- Managing the supply needs of the housing unit.

Direct supervision. In direct supervision, an officer workstation can vary from a desk with a computer and file cabinet placed in a dormitory to an elevated workstation with door, light, and other controls in a two-tiered housing unit. The control post work area should provide space for a computer, paperwork, books, manuals, and miscellaneous items needed by the officer. It should

also have lockable drawers and files. Staff toilet areas will be located in a separate space.

Remote observation. The staff posts in a remote observation setting are frequently the largest, particularly when they are enclosed. This is because the staff space must function as a self-contained operation. Within the post must be all of the control panels used to manage locks, lights, alarm systems, and so forth, plus room for records and files, and work surfaces for report writing and equipment (telephones, intercoms, computers). When the control post is fully enclosed, it often has toilet facilities for staff accessible from within the control space.

Open-counter remote observation posts (see photograph on page 154) tend to require less square footage because toilet facilities are not required within the post itself. However, remote observation control posts are frequently more spacious than necessary (exhibit 15-11), given the need for a strategic location that provides staff with a view into a variety of surrounding housing units or activity areas. Even though the post may be larger than truly necessary, the additional space should not go unused. Within the remote surveillance space can be a variety of undercounter

Exhibit 15-11. Remote Observation Control Post

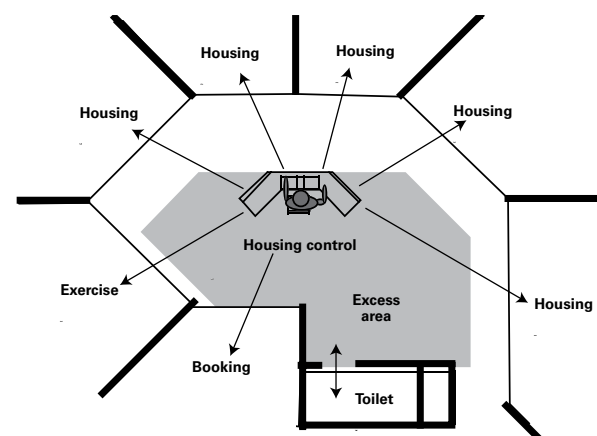

Section 3: Functional Components

storage areas that help solve some of the chronic problems of insufficient storage in jails.

It is important to realize that although the size of a remote surveillance control post may be larger than necessary, there is generally only one point in that space from which the officer typically works. That is, there is only one point where the officer's equipment for controlling locks, lights, and so forth will be located. Therefore, even if the size and arrangement of the control post tend to suggest that total view control is obtained, the true location from which the officer will operate the controls must be pinpointed with regard to the sufficiency of the views and then considered from that point.

Intermittent surveillance. With intermittently monitored facilities, the size of the staff post can be restricted to its basic needs because the design of the post is not, by concept, influenced by a need to create any specific physical or view relationship with the housing units. Its space requirements are shaped by its need for a desk surface for computer monitors or control panels and report writing, record storage, and storage of miscellaneous equipment, paperwork, and supplies.

Shape of post

ISSUE: Space or area size can be dictated by the shape of the control post.

RESPONSE: It is recommended that the actual casework required for controls be shaped to allow convenient use from a single point. This tends to dictate against long, straight counter tops and suggests work areas that are more or less "in-the-round" so that staff can easily reach all of the equipment and surfaces they need without a lot of chair or body movement.

Security

ISSUE: Clear lines of responsibility must be determined between housing unit control responsibilities and interrelationships and master control responsibilities and interrelationships.

RESPONSE: It is important to determine the control responsibilities allocated to the housing unit officers to ensure that work loads are manageable. Also, it is critical to determine the degree to which the housing unit officers' controls are duplicated and can be overridden by master control.

The following types of functions may come under the direct control of the housing unit control officer:

- Individual cell locks and door status.
- Dayroom door locks and status.



Elevated officer's workstation in a direct supervision housing unit. The elevated area allows the officer to observe both the first floor and second tier from the station.

(Photograph courtesy of Liebert & Associates.)

- Doors to various program and service areas within a cluster of housing units or directly accessible from a given housing unit.
- Cell, dayroom, associated program areas, corridor, and control position lights.
- Inmate telephones.
- Recreational TV channel and sound controls.
- CCTV monitors within the housing areas.
- Intercoms between the cells, dayroom, program areas, corridors, and other staff posts and the control position.
- Alarm systems.

It is also critical to the design of the staff post, and the housing area as a whole, to decide whether the officer will merely **observe** or physically **participate** in typical housing area activities such as:

- Distribution of meals.
- Pickup and distribution of laundry.
- Removal of waste and garbage.
- Receipt of sick call and commissary slips.
- Receipt and distribution of mail.
- Escort of inmates to and from their cells, either within the perimeter of the housing area or throughout the jail.
- Routine cleaning activities.

The choice of observer or participant role directly affects the design of remote observation control posts. If the officer is to be a participant, an open staff post would probably be needed, as opposed to a fully enclosed post. The officer's role would not similarly affect direct supervision situations because the officer is a direct participant in all housing unit activities, does not leave the housing unit, and is not ever in an enclosed control

post. Nor would it affect intermittent surveillance situations because officer movement and, thus, some degree of interaction with inmates is inherent in the concept.

If a remote method of observation is selected and the officer is to participate in activities beyond those that can be controlled electronically from within the staff post, the resulting open-counter position presents some security problems that must be addressed:

- The officer must have the ability to turn off the controls when he/she leaves the station, and there must be master control backup override in the event of an emergency. This is also true for control posts in direct supervision, where the officer has control of locks, lights, and other equipment in the housing unit.
- The entire housing area (and all of its individual housing units) has to be treated as a perimeter, the exit from which is controlled by master control rather than by the housing

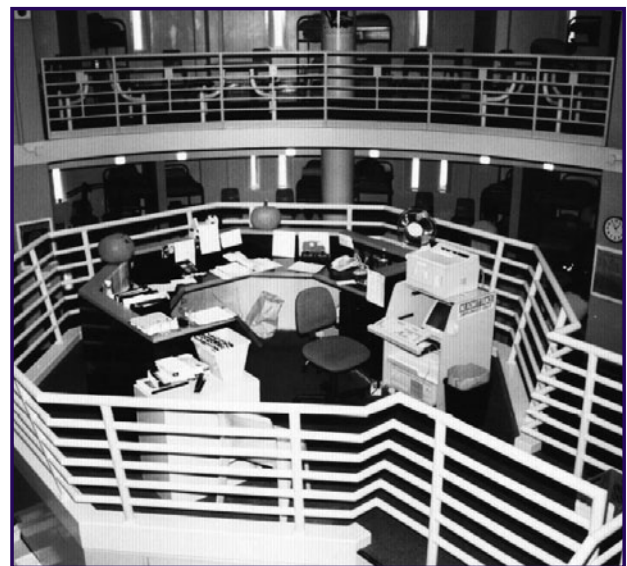

Officer's workstation in a high-security housing area.
(Photograph courtesy of Voorhis Robertson Justice Services.)

Section 3: Functional Components

control officer. This is done to limit the value of assaulting the officer and gaining control over the open-counter position.

ISSUE: It is critical for the housing control officer to have a maximized view of the housing area(s).

RESPONSE: Virtually every area in a housing unit must be visible to the officer as he/she either monitors the area from a fixed control post or moves through the housing area. Although this does not mean that a full view of the interior of every space (e.g., inmate cells) is necessary, it does mean that the officer should have a full view of at least the dayroom and the points of access to all areas within the housing unit (e.g., cells, shower areas, vestibules, visiting areas, exercise areas).

If a two-tier housing unit area is designed, it is critical to ensure that staff have a vertical view angle that allows adequate view of second-tier activities. The details of the design should accommodate view as discussed earlier in this chapter under “Basic Design Issues.”

The view provided through dayroom windows and vestibules is a key consideration. If the view angle is severe enough, especially between a fixed staff post and a housing unit, the relatively deep and thick framing used with security glazing may create more of an obstacle to the view than anticipated.

The actual view obtained through vestibules may also be much less than expected because of the interference created by the framing for glazing, the wide door frames created when jamb-mounted locks are used, and the width of the door panel, even when the upper portion of the door is glazed. Single-level vestibules can obscure vertical views in a two-tier housing unit (exhibit 15-12). When two-tier spaces are

involved, it is also important to take into account the amount of visual interference created by sliding door mechanisms. These mechanisms typically are placed above the doors and can be relatively deep, thereby blocking view into second-tier areas from adjacent control positions.

The lower-level views of dayrooms are also important to consider. Many designs have concrete masonry construction of five courses of block (40 inches) at the base of the dayroom walls. This can provide a hiding area for inmates. The designer may want to consider taking the glazing at the front of the dayrooms down to a one- or two-course level.

Communications

ISSUE: The staff control posts must be provided with proper communication capabilities.

RESPONSE: In remote observation, it is important for control officers to be in a position that allows them to communicate properly with inmates under their control and with other staff in the facility. Communication with the inmate population is fundamental to meeting inmate needs. This is not a design issue in direct supervision because the officer is in the unit with the inmates.

An inmate-to-officer communication system should provide the inmate with the ability to

Exhibit 15-12. Vertical View in Two-Tier Housing Obscured by Single-Level Vestibule

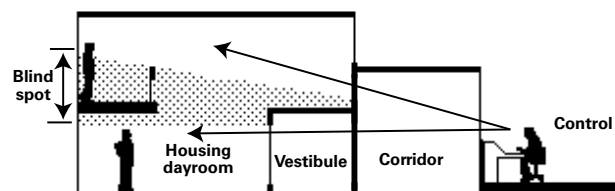

communicate at will from both individual cells and the dayroom to the staff in both the corridor and the control post. With the use of solid materials in construction (e.g., concrete masonry units, concrete, security glass), communication is typically achieved through an intercom and/or mechanical talk-through communication device. To provide privacy in dayroom-to-staff communications, a telephone might be considered in addition to the outside telephone lines that allow inmates to talk with friends and relatives.

To facilitate more normal levels of conversation between inmates in the dayroom and officers in the corridor, the designer might consider placing a passthrough or opening in the dayroom wall at approximately shoulder/mouth height. It is also important to provide a means by which staff in enclosed control posts can communicate with, and pass things to, officers outside the control post.

Miscellaneous Design Issues

The following functional-architectural issues deal with miscellaneous space and design considerations relative to the general housing areas: security vestibule, showers, storage, janitor closet, multipurpose rooms, and visiting areas.

Security vestibule

ISSUE: Identify the need for a security vestibule entry to housing units.

RESPONSE: The primary objectives in providing a security vestibule are to prevent unauthorized inmates from leaving the housing unit and to eliminate the danger of several inmates rushing an open dayroom door in an escape attempt. Also, during inmate disturbances, the vestibule provides added control and containment capabilities. However, the security vestibule also represents an additional barrier to manipulate, can diminish remote views, and can add construction costs to a project.

The key to determining the need for a security vestibule is identifying the security risk presented by the inmates housed in a particular housing area, considering the consequences to security if inmates escape their housing unit, and understanding the housing area's relationship to the security perimeter and zoning concepts of the jail. It is typical to assume that a low-security general population would be less likely to require a security vestibule leading into the space. However, such a vestibule may be deemed essential when a high-risk group is involved.

The need for a security vestibule is greatly reduced when a constantly staffed, fully enclosed, securely constructed post is located immediately adjacent to the housing units. If a housing area or pod consisting of several housing units is clearly defined as a security zone in which escape from a dayroom leads only to a limited, sealed-off housing area corridor, the need for vestibules may be eliminated. In this case, the corridor functions as one large housing area vestibule. Such an approach is especially valid when the exit from the housing area corridor is controlled by staff outside the housing areas, such as master control. However, vestibules should still be considered for use with high-risk inmates.

When a security vestibule is provided, it is important that all vestibule doors be interlocked. That is, the controls of the doors must be set up so that when one door is opened, the other(s) cannot be opened. However, such an interlock system should have an override capability so that all doors or selected sets of doors can be opened simultaneously if emergency egress or ingress is required.

In sizing a security vestibule, it is important to ensure that it is large enough to accommodate both the maximum number of people to be moved at one time and the equipment that might be moved through the space (e.g., food carts;

Section 3: Functional Components

laundry carts; emergency medical equipment such as crash carts, gurneys, and stretchers). The security vestibule should also be designed to meet access requirements for wheelchair-bound inmates or staff.

Sizing must take into account that interlocking doors limit maneuverability, especially if swinging doors are used. Swinging doors should swing out, away from the housing unit, to facilitate emergency egress and prevent inmates from barricading themselves inside the dayroom. The actual path of travel for equipment must also be considered in concert with door swings (exhibit 15-13), especially in situations where doors are located in walls perpendicular to each other rather than parallel to each other.

Showers

ISSUE: Showers or bath areas must be provided in association with each housing unit.

RESPONSE: Shower areas are typically provided on the ratio of 1 shower for every 8–12 inmates in general population areas, depending on applicable standards. Showers are typically provided instead of bath facilities. Bathtubs are most commonly found in medical housing and are used for treatment purposes.

Exhibit 15-13. Sizing of Security Vestibule To Allow for Door Swings and Passage of Equipment

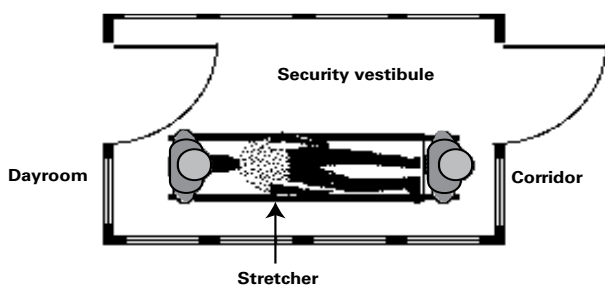

Showers can be constructed of concrete masonry walls treated with special water-resistant and durable coatings and premanufactured shower pans and floors. They can also be stainless steel cabinet units as supplied by detention equipment manufacturers, either free standing or installed in a recessed alcove designed for that purpose. In either case, the showers should use detention-quality fixtures designed to take inmate abuse and preclude suicide attempts by eliminating protrusions from which an inmate can hang him/herself.

Regardless of the shower type used, it is important to include a small drying and dressing area or alcove just outside the shower area and ways to contain drips and spills from the shower area. A nonslip surface should be applied to the floor immediately adjacent to the shower area, and curbing can help contain excess water. (In ADA-compliant shower areas, the curbing must have a sufficiently low profile that wheelchairs can pass over it easily.)



Showers in a housing area with both a door to the dressing area open at the top and bottom and a shower curtain that is clear at the top and bottom for the shower area.

(Photograph courtesy of Voorhis Robertson Justice Services.)

A key design problem with shower areas is striking the proper balance between the modesty required by the inmate and the needs of staff to observe the area. It is recommended that staff at least be able to see the entry to the shower area, and that the entry and shower area not be fully exposed to the dayroom and other inmates. Use of security glass block side walls can aid in developing some visibility without totally sacrificing modesty. Shower curtains, doors, or screens should at least allow a head-and-shoulder view of the inmate and, preferably, a foot-and-ankle view as well. It is useful to provide a capability for hanging towels and clothing adjacent to the shower area.

Proper ventilation of the shower area is also important to prevent moisture and odors from spreading to adjacent dayroom areas and to prevent mildew from building up in the shower area.

Storage

ISSUE: Housing areas require adequate storage adjacent to or within the area.

RESPONSE: It is important that storage capabilities be provided to service the housing areas. These storage capabilities are not meant to supplant central storerooms, but to allow a convenient way to respond to the daily needs of inmates. Such localized storage areas might contain extra linens, spare mattresses, toiletries, paper products, forms, recreation equipment such as cards and games, and other commonly used supplies. In direct supervision housing units, it is particularly useful to have storage space located within the unit.

Janitor closets

ISSUE: Maintenance of the housing units can be facilitated by providing a janitor closet in the area.

RESPONSE: A small janitor closet with a floor sink, mops, buckets, cleaning supplies, floor buffers, and so forth can be a great benefit to the maintenance program of the facility. Convenient location in the housing area promotes the use of the equipment by inmates. The janitor closet should have shelves for the storage of cleaning supplies, a splash basin, and a hose and hose bib that can be used to wash down areas as necessary. It should be equipped with a smoke detector because of the presence of cleaning fluids and should be a lockable space controlled only by staff. In two-tiered housing areas, a janitor's closet should be located on each tier so inmates are not required to carry heavy cleaning equipment and full mop buckets up a flight of stairs.

Multipurpose rooms

ISSUE: To keep the movement of inmates within the facility to a minimum, it is desirable to provide multipurpose room(s) in general population housing units.

RESPONSE: The concept of bringing services to inmates rather than taking inmates to services became popular with the advent of direct supervision. As a result, jurisdictions have found it desirable to include a multipurpose space in general population housing units. These rooms are generally located off of the main dayroom and can be used for purposes such as small classes, counseling, medication distribution, and haircuts. Using space in the housing area to provide services reduces the amount of inmate movement within the facility and reduces staff time devoted to moving inmates. Small multipurpose rooms in the housing areas generally will not eliminate the need for larger multipurpose rooms and classrooms designed to hold larger groups from different housing areas.

Section 3: Functional Components

Visiting areas

ISSUE: Visiting areas adjacent to or inside the housing area can reduce staff time, movement, and scheduling difficulties associated with centralized visiting.

RESPONSE: Providing inmates with access to visits with family and friends, either through noncontact visiting booths connected to the housing area or through the use of video visitation, can greatly reduce the number of facility staff devoted to the visiting function. The housing officer would be responsible for monitoring visiting as part of his/her regular duties, eliminating the need for a visiting officer or a movement officer to escort the inmates back and forth to the visiting area. Visiting areas adjacent to or inside housing areas can also expand the time allocated for visits and the number of visits an inmate can receive in a week because an additional officer is not required to supervise the activity.

Space List

Some of the typical spaces that might be found within the general housing component include:

- Cells or dormitories.
- Dayrooms (one per housing unit).
- Security vestibules (as needed).
- Shower area (1 per 8–12 inmates, per code).
- Dayroom inmate toilet area.
- Storage.
- Janitor closet.
- Staff control post (one per housing area recommended).



Video visitation area in the dayroom of a housing area.
(Photograph courtesy of Liebert & Associates.)

- Staff toilet (one per staff post).
- Multipurpose room.
- Visiting area.

Local codes and ADA guidelines regarding accessibility requirements should be consulted when planning these spaces.

Some spaces that might be associated with general housing, depending on operational programming, movement, and surveillance concepts, include:

- Indoor and/or outdoor exercise.
- Sick call/medical exam room.
- Video court appearance room.
- Food reheating/distribution area.
- Linen storage.

Relationships and Components

Exhibit 15-14. Relationships Between Housing Unit Space Components

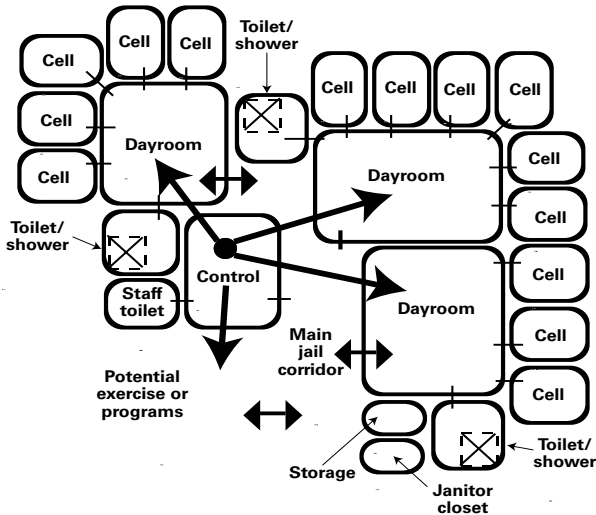
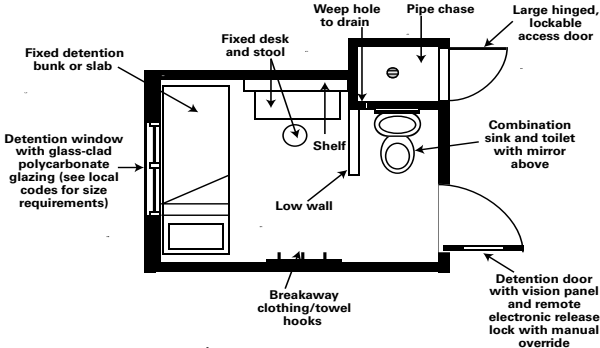

Exhibit 15-15. Component Diagram of a Typical Cell



Special Housing

The special housing areas of a jail accommodate all male or female inmates who by behavior, condition, or unique security risk require spaces with special design characteristics and/or spaces separate from those used by the general population. Inmate groups for whom special housing is described in this functional-architectural component include the following:

- **Work release/periodic-sentence inmates**, who are regularly released from and readmitted to the jail to go to a job or school during the time they are serving a sentence or being detained prior to trial.
- **Inmate workers**, who are given work assignments within the facility and outside of their housing unit (e.g., kitchen or laundry duty and/or general facility maintenance) or outside the facility on supervised work crews providing services to the jurisdiction (e.g., road cleanup, landscaping).
- **Protective custody inmates**, who need protection or separation from the rest of the inmate population but do not pose a threat to others or themselves.
- **Juveniles detained as adults**, who are typically 16- to 18-year-olds who are to be tried as adults because of the nature of the crime with which they are charged. (Local and state laws and the Juvenile Justice and Delinquency Prevention (JJDP) Act should be consulted to determine the definition of “juvenile” and criteria regarding assignment of “adult” status in criminal proceedings, as this varies widely from state to state.)
- **Medically isolated inmates**, who must be separated from others because of their medical status, because they are infected with a communicable disease, or because they have a health condition that requires the supervision of medical staff or separation from the general population.
- **Inmates serving disciplinary time**, who can be separated from the general population as punishment for serious rule violations.
- **High-security inmates**, who pose a verifiable threat to staff and other inmates (sometimes referred to as “administrative segregation”).
- **Suicidal inmates**, who have already attempted suicide or have suicidal tendencies so apparent that they need special observation and protection. They do not necessarily include inmates who may have suicidal tendencies but can be detained in a general housing unit that is observed in a constant manner.
- **Inmates with mental disabilities**, who are known to have serious mental health problems or who demonstrate sufficiently abnormal behavior to merit special observation. This category can also refer to inmates with developmental disabilities who may be victimized in the general population.
- **Intoxicated inmates** who are under the influence of alcohol or drugs.
- **Inmates with physical disabilities** who require special design accommodations. These inmates can be found in any of the special housing categories, but do not constitute a group for whom a special unit is created. Designs of special housing areas, therefore, must accommodate the needs of inmates with physical disabilities as well. More information on design considerations for these inmates is provided in chapter 15, “General Housing.”

These special categories of inmates pose separation and management problems in all jails, but those



problems are more acute in small jails. Some of these categories of inmates require significantly different types of space and/or different levels of separation and observation than do inmates in general population housing. Historically, small jails have had inadequate space and observation capabilities to satisfactorily accommodate these various groups, resulting in serious operational or legal problems.

One option in planning and design in smaller jails is to seek alternative housing for special inmates. Removing them from the small jail is beneficial to the efficient development of space and the management of operational problems facing the limited staff and resources of the smaller jail. If some or all special categories of inmates must be accommodated at the small jail, the emphasis must be on designing space flexibly so that the limited number of beds available can accommodate as many different types of inmates as possible.

Providing for the separate needs of different types of inmates remains perhaps the greatest challenge facing jail designers. A further challenge is that standards typically require that inmates in administrative segregation, protective custody, disciplinary detention, and other special forms of housing have the benefit of the same general conditions and the same access to health care, exercise, and other services as do general population inmates. In other words, occupancy in a special housing unit does not justify the loss of fundamental rights, conditions, and privileges.

In reviewing the issues addressed in this functional-architectural section, readers should refer to the concepts presented in chapter 5, “Classification/Separation,” and chapter 6, “Surveillance/Supervision,” many of which have a direct impact on the development of special housing space.

Key Decisions

The following decisions have a fundamental effect on design requirements and therefore should be made when evaluating the role of special housing:

- Which types of special inmates must be accommodated at the jail and which can be taken directly to alternative facilities, such as work release centers, detoxification centers, or mental health facilities, or be housed in other jurisdictions?
- What is the average daily population and maximum length of stay for each type of special inmate to be accommodated by the new jail facility? Does your facility have a large enough special housing population to require separate housing units for each type, and do these types of inmates stay, on average, several hours, overnight, or through adjudication? (Average daily population and duration of stay will affect the nature of the space provided and the nature of the management problem posed by the groups.)
- To what degree can it be assumed that certain special housing spaces can be shared by different types of inmates because of the limited frequency with which such inmates are actually received at the jail?
- Who will manage and control the activities of the various special inmate groups? If special treatment or supervision is required for any inmate group, who will provide that treatment and/or supervision?

Detail Issues

The functional-architectural issues discussed in this chapter address the development of special housing areas for the following populations: work release/periodic-sentence inmates, inmate workers, protective custody, juveniles, inmates requiring medical isolation, disciplinary

detention/administrative segregation inmates, inmates with mental or developmental disabilities, those who are suicidal, and those who are intoxicated. Some classifications of special inmates are grouped together because the characteristics of their housing areas are similar. The areas could be used interchangeably by the different classifications, assuming, of course, that the classifications will not be mixed together in actual practice. Attaining such interchangeability assumes that the frequency and/or timing of a special inmate's admission are appropriately limited.

The concept of shared space and flexibility in housing use is explored in depth in section 2 in chapter 5, "Classification/Separation, and chapter 10, "Functional Components and Relationships." Many of the design considerations for the dayroom area, cells, and other aspects of the housing units discussed in chapter 15, "General Housing," also apply to special housing. Readers are encouraged to refer to these chapters in conjunction with the current chapter.

Work Release/Periodic-Sentence Inmates

ISSUE: The basic living needs of inmates on work release and those with periodic sentences¹ are similar to those of all inmates and should be accommodated.

RESPONSE: The following characteristics are appropriate to the physical environment for work release and periodic-sentence inmates.

- Sleeping areas may be dormitories, multiple-occupancy cells, or single-occupancy cells. When dormitories are used, some provisions should be made for privacy and property protection. Privacy can be provided by the use of partial- or full-height partitions (exhibit 16-1).

Exhibit 16-1. Privacy Partition in Sleeping Area

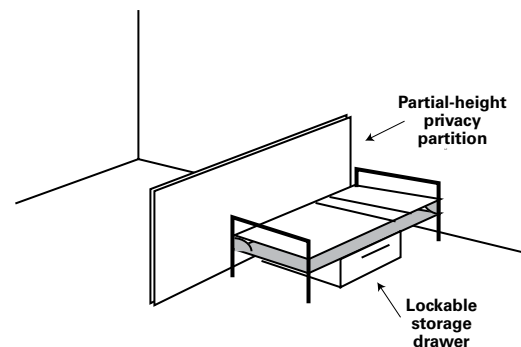

- The sleeping room/area should include these items:
 - Bed.
 - Desk.
 - Chair or stool.
 - Light fixture, possibly controllable by the inmate.
 - Lockable storage locker or cabinet.
- Dayroom space should be provided. It should be separate from the sleeping areas, especially if work release/periodic-sentence inmates work different shifts and the acoustic privacy of sleeping inmates would be disturbed by inmates who may be watching television, talking on the telephone, showering, or conversing.
- Sufficient shower areas should be provided to allow work release inmates to expeditiously get ready for their work day. Showers should provide a high degree of privacy, although staff observation from outside the area should be accommodated through a small vision panel or through partial-height doors. The panels may be shuttered or screened to prevent unauthorized view.

¹ Periodic-sentence inmates are most commonly those that serve weekends in jail ("weekenders") and stay at their home during the work week, although there are other variations.

Section 3: Functional Components

- Whether or not a security vestibule is necessary as an entry to the housing unit depends on the agency's philosophy about work release/periodic-sentence inmates, the environment, and the proximity to other areas of the jail. If located correctly, and if there is a secure vestibule from the work release/periodic-sentence inmate housing unit into the jail, a security vestibule to the exterior of the building may not be required
- Furniture should be durable, but need not be security quality or fixed in place.
- A direct line of sight into the sleeping and dayroom areas is useful, even if observation round policies require staff to enter both areas periodically to observe inmates (exhibit 16-2).
- The housing unit should have a means for inmates to communicate with staff at a constantly staffed post and, possibly, in the adjacent corridor. Communication between inmates in a housing unit and roving or medical staff may be accomplished without requiring entry into the housing unit, although the preferred option is to provide face-to-face contact whenever possible.
- Lighting for the dayroom should be controlled by a switch separate from that for the lighting

Exhibit 16-2. Direct Line of Sight Into Sleeping and Dayroom Areas

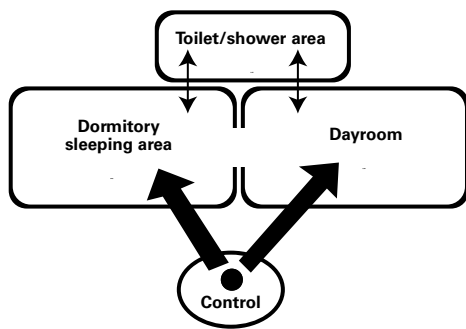

for the sleeping areas because of the separation of the areas and different schedules.

- Natural light should be introduced to both sleeping and dayroom areas, but should be minimized and controllable in the sleeping areas if work release schedules require sleeping during daylight hours.
- Additional considerations in housing units occupied by work release or inmate workers may include:
 - Ground fault outlets in the sleeping rooms or dayrooms for inmate workers to accommodate radios, televisions, and coffee pots, if those items are allowed by policy.
 - Televisions that inmates control in the dayrooms.
 - Access to washers and dryers to allow work release inmates to launder their work clothing and/or personal clothing.

Security

ISSUE: Although work release and periodic-sentence inmates are generally considered to be low-security classification, security is still a consideration.

RESPONSE: Some vital security considerations that must be addressed are principally directed toward the prevention of contraband passage and vandalism in the facility:

- The elements of the internal security zone that defines the work release area—principally those elements that double as the main security envelope of the building—must be sufficiently secure to preclude the passage of contraband into the work release area by outside parties: secure wall construction, nonoperable windows, security glass, and at least two doors between the area and the outside.

- It is not uncommon in larger jail systems for work release/periodic-sentence inmates to be housed in a separate facility, either on the same campus as the main facility or elsewhere. This separate facility mitigates the need for increased security beyond that required for minimum-security inmates.
- The entry/exit used by work release/periodic-sentence inmates should be separate from the entry and exit for the regular inmate population and the public, if possible (exhibit 16-3). If not possible, a strictly managed entry/exit sequence should be implemented to minimize contact with areas normally used and occupied by the other inmates. (More information on the conditions under which the normal intake-release area can be used is



Lobby for entry into work release housing separate from the main facility lobby.
(Photograph courtesy of Jim Rowenhorst.)

presented in chapter 14, “Intake-Release.”)

- There should be an area or areas in which the incoming work release/periodic-sentence inmates can be searched, change clothes, and store their work clothing (exhibit 16-4). This area should accommodate either a standing metal detection unit or simply a hand-held metal detector. Sobriety testing equipment is also useful to test incoming inmates suspected of intoxication.
- Locker facilities outside the sleeping area and dayroom should be provided to secure the valuables, work tools, backpacks, etc. that inmates are allowed to possess when leaving the facility. Lockers preclude the problem of theft.
- The area should be totally separate from all other housing areas and from

Exhibit 16-3. Entry/Exit for Work Release/Periodic-Sentence Inmates



Exhibit 16-4. Entry Sequence for Work Release/Periodic-Sentence Inmates

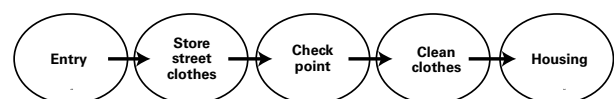

Section 3: Functional Components



Lockers in the dayroom of a work release unit used by the inmates to store their valuables.

(Photograph courtesy of Jim Rowenhorst.)

as many of the main traffic corridors of the facility as possible. If work release/periodic-sentence inmates use program and exercise areas used by the general inmate population, staff should take care to ensure that no contraband has been left by a work release/periodic-sentence inmate for other inmates.

- Separate laundry facilities should be provided to preclude the possibility that identifiable personal laundry becomes a vehicle for contraband passage.
- Some subdivision of the housing area is appropriate to enhance general control and security between work release inmates and periodic-sentence inmates and/or between inmates released for different work shifts (e.g., if 24 beds

are provided overall, the area could be divided into two 12-bed areas or three 8-bed areas).

Bed capacity

ISSUE: Sufficient capacity should be provided to accommodate the surges in inmate population created by weekend sentencing.

RESPONSE: Weekend sentencing is used as an option in many jurisdictions so that the inmate can work all week at his/her job and spend only free weekend time in the jail. However, weekend sentencing typically causes problems for the jail, in that it tends to significantly increase the inmate population at a time when there is a normal increase in the number of arrests and jail bookings. This surge must be recognized in planning so that adequate capacity is available in the work release/periodic-sentence inmate housing areas and increased intake and release requirements can be accommodated without conflicting with other inmate admissions. It is common to plan an intake area in the work release lobby for work release intakes and weekend admissions. This allows these inmates to be processed into the facility without overwhelming the facility intake area and reduces the potential for contraband to enter the main jail facility.

ISSUE: The male work release population must be kept separate from the female work release population.

RESPONSE: Women are also sentenced to work release or periodic stays. The same levels of separation between male and female housing areas discussed in chapter 5, “Classification/Separation,” in section 2 must be maintained in the work release/periodic-sentence housing areas: physical,

sight, and sound separation. This is particularly true if the work release/periodic-sentence areas are intermittently monitored, as is frequently the case.

In addition to the housing areas, search areas should be private, if not separate, for men and women. A common entry is appropriate, but a separate waiting area is desirable if the area cannot be directly observed and inmates are not immediately processed by staff.

If the female work release/periodic-sentence inmate population is very limited in number, the women might be housed in general housing or another unit used for sentenced female inmates. In this case, the contraband passage and property protection risks must be managed administratively rather than architecturally.

Inmate Workers

ISSUE: The basic living needs of inmate workers must be accommodated.

RESPONSE: The inmate worker housing area has the same characteristics detailed above for work release/periodic-sentence inmates. Reference should be made to that information in developing the inmate worker space.

ISSUE: Inmate worker housing areas should be properly located.

RESPONSE: Inmate worker housing areas should be kept separate from the other inmate housing areas, if possible, consistent with surveillance needs. They should be near the functional areas where the inmate workers perform their daily duties, such as the laundry and food service areas. The inmate worker area should also be within the secure perimeter of the jail because inmate workers are not normally free to move outside of the facility unless they are on supervised work crews. Those inmate workers

who perform tasks outside of the facility are often housed in work release housing, with the only difference being that they are picked up daily for supervised work crews rather than going to their own job.

It is critical to keep the internal inmate workers separate from work release/periodic-sentence inmates. Failure to provide this separation creates a natural chain of contraband passage from work release inmate to inmate worker to general housing inmate, because inmate workers are frequently in other areas of the facility as part of their laundry, kitchen, janitorial, or maintenance duties.

Protective Custody Inmates/Juveniles

The characteristics of housing facilities for inmates in protective custody and for juveniles detained as adults can be quite similar. These two groups are dealt with jointly in this section because of those similarities. Additionally, in smaller jails, the infrequency of juveniles being detained as adults and of protective custody inmates being held could allow this area to be used interchangeably.

As a rule, the design of the protective custody unit is fundamentally the same as that of a general housing unit. Consequently, the issues and responses regarding dayroom and cell space raised in chapter 15, “General Housing,” apply.

In larger jail systems, one or more general population housing units are set aside to house protective custody inmates, depending on the population at a given time. However, in the smaller jail, the limited size of the protective custody group means the number of beds allocated for protective custody housing could be accommodated in the kind of “swing” or special management housing unit discussed in chapter 5, “Classification/Separation.” Such a swing unit might be adjacent to the female housing unit or

**Section 3:
Functional Components**

another special housing unit so that it could be used for an overflow female or special housing population when not being used for protective custody.

Housing flexibility

ISSUE: Flexibility in housing assignments should be a characteristic of protective custody housing in the smaller jail.



RESPONSE: The flexibility of small protective custody or swing housing units can be increased in various ways, each of which involves careful detailing and design:

- Develop each individual housing unit with minimum capacity. Specifically, restricting each protective custody housing unit's capacity provides an ability to adjust to the varying natures of the populations to be housed in the units.
- Provide a door in the dayroom partition that divides individual units to allow, for example, two 3-bed areas to function as one 6-bed area when inmates of identical classifications are

involved (exhibit 16-5). This flexibility also combats the problems inherent in two-bed areas, namely, a one-on-one inmate situation that is typically thought to be undesirable. It also prevents the possibility of isolation when only one person is in a unit, when immediately adjacent are two inmates of the same classification.

- It is important that the door dividing the two housing units be acoustically treated and have a security threshold that limits sound transfer and precludes the passage of contraband when inmates of different classifications are in the adjacent areas.
- Develop a swing cell between two adjacent housing units that can open to either of them to easily change the capacity of either area.
- Provide a second access to one of the cells so that special housing needs can be accommodated on those unusual days when there is a full variety of inmate types in the facility and too few separate areas to manage them (exhibit 16-6). In these circumstances,

Exhibit 16-5. Door in Dayroom Partition

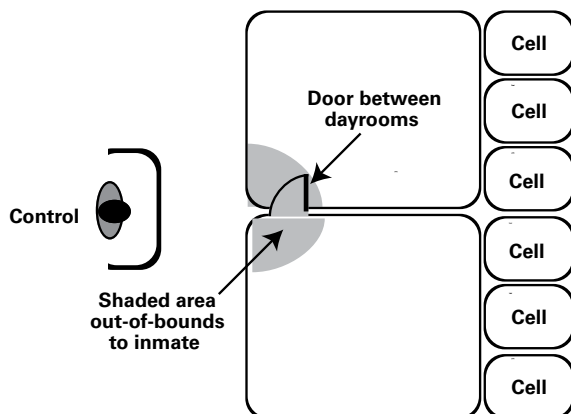
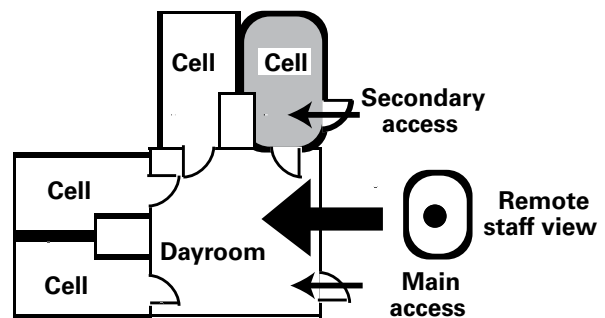

Exhibit 16-6. Secondary Access to Cell



which are expected to be rare and of short duration, access to dayrooms and showers will have to be scheduled and managed by staff.

If this possibility is to be incorporated into the design to limit the overall amount of bed space and still cover all circumstances, the constant presence of staff is appropriate. Consequently, it is recommended for smaller facilities that when a housing area is developed as versatile swing, or special management space, protective custody areas be remote surveillance areas.

Separation

ISSUE: Protective custody/swing areas should be separated from other housing units, and the units within the protective custody/swing areas should be separated from each other.

RESPONSE: When housing protective custody inmates, providing the capability of full physical, sight, and sound separation from the other general population units is important. For the swing/special management concept, it is also important to provide separation between the various housing units within the area, because inmates of very different classifications might be housed in the area at the same time. It is imperative for protective custody areas to be separated from disciplinary detention and high-security areas, as inmates in those areas might pose a direct physical, visual, or verbal threat to inmates who are being protected.

ISSUE: Housing juvenile offenders in adult jails can pose serious design and management problems.

RESPONSE: In 2004, youth younger than 18 years of age accounted for 1 percent of jail

inmates. Of those, 87 percent were held as adults.² Juveniles pose a major management and housing problem in jails of all sizes, especially if law or standards require site and sound separation at all times. As with protective custody inmates, designing space for juvenile offenders requires full separation from other general population or special housing inmates in the facility. Generally, juveniles make up a very small portion of the population in any jail, so it is important that the jurisdiction use the concept of swing housing, described above, when planning for juveniles. Additionally, in housing areas for juveniles, the availability of multi-purpose space for educational programming for underage offenders may be important.

Medical Isolation and Medical Housing

Jail administrators should refrain from housing inmates who have long-term and serious medical problems for any extended period, unless the facility has designed a special medical housing unit and has full-time medical staff on duty in that area. Inmates with serious medical problems present major challenges in terms of providing proper care and facilities. This section discusses design characteristics, location, and security with respect to the housing of people suspected of having, or known to have, diseases or illnesses that might be contagious/infectious (e.g., serious flu virus, tuberculosis) and those who require supervision by medical staff while they are being treated for or are recovering from a medical condition. It is recommended that new jail facilities incorporate negative pressure isolation cells in the design of their medical units to accommodate inmates with contagious/infectious diseases. In small jails that is not always possible, and appropriate alternative facilities must be identified

² Howard N. Snyder and Melissa Sickmund, *Juvenile Offenders and Victims: 2006 National Report* (Washington, DC: U.S. Department of Justice, Office of Justice Programs, Office of Juvenile Justice and Delinquency Prevention, 2006).

Section 3: Functional Components

for inmates diagnosed with a serious contagious illness.

In circumstances where only a cold, a minor virus, or a mild influenza is involved, medical isolation needs might be accommodated by simply isolating the inmate in his/her regular cell. More information on nonhousing health care areas (e.g., examination areas, medication storage) is given in chapter 17, “Health Care.”

Characteristics

ISSUE: Medical housing areas should accommodate the medical and personal needs of the inmate.

RESPONSE: A medical housing area should have the following design characteristics:

- It should basically be of high-security construction because it will likely accommodate the full range of classifications served by the jail.
- A dayroom area, which should accommodate a shower, is desirable

adjacent to medical cells. If no dayroom space is available, medical isolation cells should include a shower if this practice complies with local codes. Accommodation for television viewing, telephone access, and a visitation area are additional considerations, especially if such amenities are available to other inmates.

- Cells should be single occupancy.
- Cells should be located so as to facilitate frequent observation by medical personnel and security staff.
- The size of cells should be dictated by the types of furniture and equipment within them. Besides a possible shower, it is useful for the bed to be accessible from more than one side. An appropriately designed medical cell frequently exceeds 100 square feet in size.
- The bed should be fixed in place and comfortable. The use of traditional

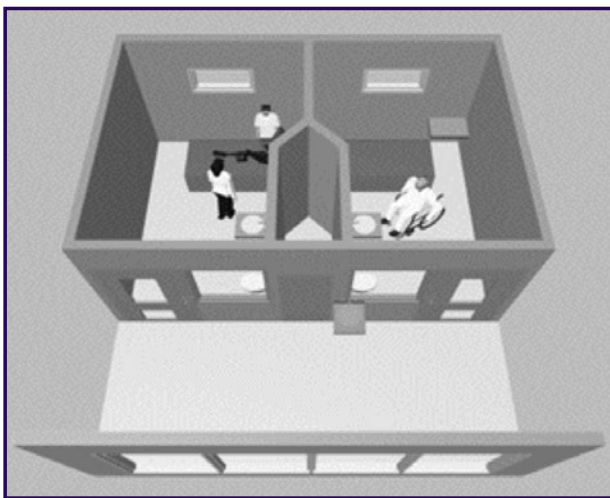

Overhead of medical isolation cells with Americans with Disabilities Act (ADA)-compliant plumbing fixtures, medical bed accessible from three sides, and adjacent airlock vestibule. Showers are not in the cell.



Acute medical cell with attached shower area on the right.
(Photograph courtesy of Voorhis Robertson Justice Services.)

hospital beds could also be considered. If hospital beds are used, the size of the doors should accommodate the bed for emergency evacuation of nonambulatory inmates.

- Inmates should be able to communicate directly with staff. This capability should, perhaps, include a nurse call button or panic alarm that allows the inmate to easily alert staff of a need.
- The needs of inmates with hearing or vision impairments must be accommodated in the cells.
- A detention-quality, Americans with Disabilities Act (ADA)-compliant, toilet and sink should be provided; separate fixtures are recommended.
- A small, fixed-in-place, detention-quality desk and chair or stool should be provided.
- A mirror and shelves with collapsible security hooks should be provided.
- Cell doors should have a lockable food passthrough.
- Lights should be controllable by staff, but an option for some inmate control might be desirable.
- Natural light should be provided to the area through a secure means.
- Access to power, although not necessarily inside the cell, must be considered, as it may become necessary to house inmates with conditions requiring medical equipment powered by electricity.
- Medical isolation cells should be designed for negative pressure, where the air from the cell is circulated out

of the building and not through any other areas of the facility.

- A floor drain should be provided either in the cell or just outside it.

Location

ISSUE: The location of medical cells should facilitate both delivery of medical services by health care staff and surveillance by security staff.

RESPONSE: The examination rooms, medication storage area, and offices for medical staff constitute the health care component of the facility and should be located conveniently in relation to medical cells, although adjacency is not required if surveillance needs are better served by some separation.

Regarding surveillance, the design should, if possible, allow for observation or surveillance from a constantly staffed post such as master control and/or an officer's or nurse's desk, if a nurse's position is part of the facility program. Medical isolation cells should also be located so that other staff can easily provide additional periodic observation but without overexposing cells to visibility to other inmates in nearby housing units. Providing for this easy periodic observation is a must if cells are not located in direct line of sight of a constantly staffed post.

In considering these security-related spatial affiliations, it should be remembered that inmate patients can present the same potential security risks as any other inmate, especially if they are fully ambulatory (exhibit 16-7).

Security

ISSUE: Medical isolation inmates may represent a danger to themselves or others.

RESPONSE: The design of medical isolation cells and the selection of furnishings should take into consideration the potential for

Exhibit 16-7. Security-Related Spatial Affiliations in Medical Housing

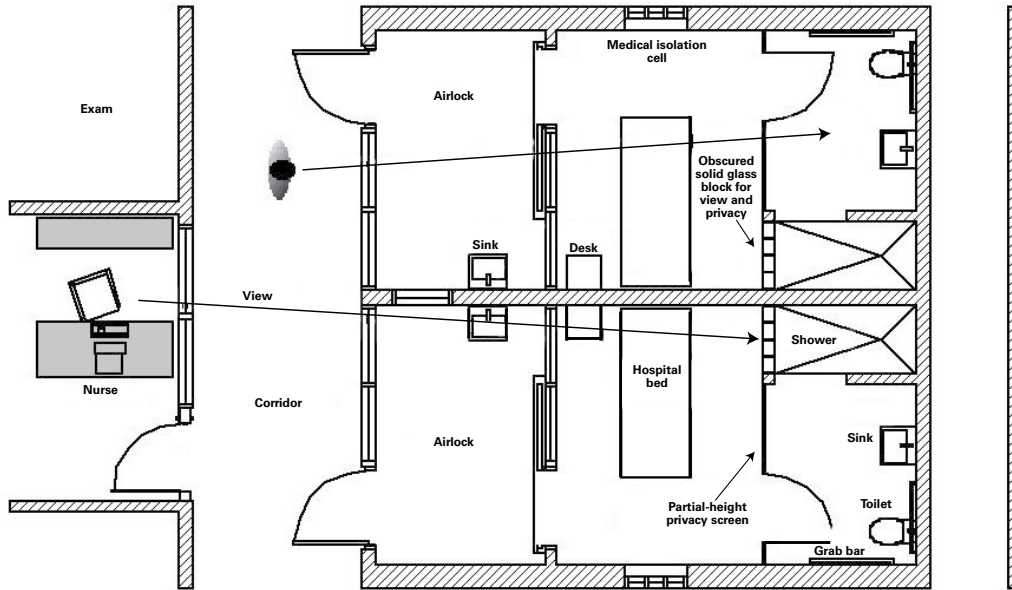

suicide or assaultive behavior and eliminate visual blind spots and bars, hooks, and other protrusions from which inmates could hang themselves or areas that could provide hiding places. Further, the design should minimize joints, pockets, and other places that could be used to hide contraband and weapons.

Occupants of medical isolation cells may have poor coordination due to illness or injury. Consequently, the design, furniture, and fixtures should not contribute to accidental injury. Fixtures should have rounded or beveled edges, there should be ample room to move around, and protrusions at eye/head height should be minimized.

Disciplinary Detention/Administrative Segregation

ISSUE: The design of housing areas used to house inmates who are on disciplinary detention or who pose a serious threat to other inmates

and staff (administrative segregation) should accommodate the security risks posed by the inmate and be responsive to the punitive aspects of placing an inmate in that housing area.

RESPONSE: An inmate is placed in disciplinary detention because of a serious violation of facility rules. Disciplinary detention is meant not only to separate the offending inmate from the rest of the population, but to discourage future bad behavior by denying the inmate some of the privileges and amenities available in other areas. Inmates are placed in administrative segregation because they have proven to pose a serious threat to staff, other inmates, or the facility by virtue of the offense(s) they are charged with, a history of extreme violence while in custody, or gang affiliation. A more Spartan living environment is a general objective of disciplinary detention/administrative segregation. However, this does not include depriving the inmate of basic rights to



An austere disciplinary detention cell with concrete bunk (the mattress was temporarily removed from the cell), steel desk, food pass, and stainless steel combination fixture.

(Photograph courtesy of Voorhis Robertson Justice Services.)

well-ventilated, temperature-controlled, sanitary, well-lit, and healthful conditions.

The characteristics of a disciplinary detention or administrative segregation area are as follows:

- It should be high security in general construction approach, emphasizing durable, cleanable, and vandal-resistant materials, furnishings, equipment, and hardware.
- It is recommended that there be a small dayroom adjacent to the disciplinary detention/administrative segregation cells. The dayroom could be used for talking on the phone, watching television (if allowed), and other passive recreation. An outdoor or indoor/outdoor exercise area should be provided for use by administrative segregation inmates. Such a space should be sufficient to allow the inmate to obtain required daily exercise. A dayroom shower facility should be easily accessible from the disciplinary cell(s).
- No vestibule is needed because the dayroom essentially functions as a vestibule. This is



A secured shower in an administrative segregation unit. Note the ports used to remove restraints.

(Photograph courtesy of Voorhis Robertson Justice Services.)

because the inmate is routinely locked into the detention/administration cell for all but a limited time for exercise and then is generally alone.

- Natural light should be provided to cells in a secure way.
- Cells should be larger than normal cells, given the extensive time that inmates are required to remain in the cell.
- Inmates should be able to communicate directly with staff, usually through an intercom in the cell, but audio monitoring capabilities should be controllable by staff.
- The cell should have a fixed bed, a detention-quality toilet and sink fixture, a desk and chair

Section 3: Functional Components

or stool, a security mirror, security shelves, and collapsible hooks for clothes and towels.

- Light fixtures should be controlled by staff.
- Cell doors should have a food passthrough and restraint port.

Security view

ISSUE: Constant observation of the disciplinary detention/administrative segregation area is essential.

RESPONSE: Observation should be provided from a constantly staffed post for effective control over the disciplinary detention/administrative segregation area. It is also advisable that this space be in a location that other staff can easily observe when passing by.

Regarding observation, it is not necessarily desirable to have total visual access to the cell by fully glazing or opening the cell front (door and front wall), especially if this exposes the inmate to other inmates in the facility and vice versa. A more limited door window and sidelight sized and shaped in deference to available view angles from nearby staff posts, and that are adequate to allow observation of key parts of the cell, would be sufficient in most cases. In general, a partial view of the bunk and open cell area, and a view above the toilet fixtures provide sufficient remote observation.

Separation

ISSUE: Disciplinary detention/administrative segregation cells should be separated from the other housing areas.

RESPONSE: The disciplinary detention/administrative segregation area might be observed from a staff control post that also provides observation of other housing areas. If so, the design of the area should provide for physical, sound, and sight separation

from the other housing units to the greatest degree possible.

Flexibility

ISSUE: The disciplinary detention/administrative segregation area may serve other special housing needs.

RESPONSE: The high-security construction of the area, the presence of a dayroom and shower, and the visibility of the area from a staff post provide conditions under which the area could conceivably be used to house other classifications of inmates under certain circumstances. For example, if the facility were to become overcrowded and no one was being held in disciplinary detention/administrative segregation, it might be appropriate to use the housing unit, on a short-term basis, to help relieve the crowding. In that circumstance, the fundamentally hard and Spartan character of the disciplinary detention/administrative segregation housing area should be offset by providing amenities. It would be desirable, therefore, to consider installing outlets for television, jacks for telephones, and other amenities in the dayroom. A small table and seating in the dayroom would also add flexibility to use of the area.

Mental Illness/Suicide Threat/Intoxication

Inmates who appear to have significant mental illness, pose serious suicide threats, or are intoxicated by drugs or alcohol require spaces that have special characteristics that are similar to those of disciplinary detention/administrative segregation inmates. In smaller jails, the infrequency of housing some of these classifications creates the possibility of a shared-use area.

Because suicidal, mentally ill, or intoxicated inmates require special care and close observation, jurisdictions are advised to seek alternatives

to jail for these inmates, unless the facility is designed to accommodate these inmates. Many jails have no choice but to accommodate such inmates, if only until other arrangements can be made. For example, the mentally ill must sometimes be kept for extended periods until a court order can be obtained to permit transfer to an appropriate mental health facility. Intoxicated inmates charged with a serious crime may also have to be held in special quarters while they recover, if outside detoxification facilities are not available.

The functional-architectural issues regarding these spaces assume only the briefest of stays for these inmates. However, especially in the case of mental illness or suicidal ideation, stays may be much longer if appropriate mental health facilities are not available, and the jail design should provide for this circumstance.

Because of the unique characteristics of these spaces, it is assumed that they typically will not be able to accommodate other classifications of inmates.

Characteristics

ISSUE: The special housing needs of suicidal, mentally ill, and intoxicated inmates must be accommodated.

RESPONSE: Some recommended characteristics of the spaces used for these special groups are as follows:

- The area should be of high-security construction that is durable, easily maintainable, and uses vandal-resistant equipment, hardware, and materials.
- A dayroom or small corridor area should be adjacent to the cells, if possible. This space provides an alternative to confinement in the cells and a useful sound containment barrier. If a dayroom cannot be provided, consider placing the cells in an area that provides some sound isolation from the other housing areas and the program areas.
- A shower should be easily accessible from, but not within, the cells.
- No vestibule is required for this area, but a sound containment vestibule might be useful.
- Natural light should be provided if possible, but not if it precludes a good observable location for the cells.
- The cells should be provided with a detention-quality toilet and sink fixture. The water supply should be restricted to cold and warm water to preclude scalding possibilities. Fixtures should be easily accessible but out of the way to preclude injuries caused by stumbling.
- On occasion, especially in detoxification cells, a raised slab approximately 8 inches above the floor should be provided for sitting or sleeping. However, it is important to follow state guidelines, some of which prohibit the use of raised slabs in detoxification cells.
- Cells should be large enough to allow easy movement by officers who may have to struggle with, or restrain, inmates; fixtures and slabs should not be too difficult to negotiate.
- No hardware or furniture should be in the cells (e.g., desk, stool, shelves, hooks, or mirror). There should, however, be sufficient room to accommodate mobile restraint chairs, if used.

Section 3: Functional Components

- Ceiling height should be at least 9 feet so that light fixtures, sprinkler heads, and so forth are generally inaccessible to the inmate.
- Lights should be controlled by staff. There should be a nightlight feature in the cell, and the light level should be adjustable to accommodate the comfort of the inmate and the varying observation needs of staff.
- The air from the space should not be recirculated.
- Openings in grills covering supply and return air ducts should be small, so as to preclude suicide attempts.
- All edges should be rounded or beveled. Padded surfaces are desirable for suicidal inmates, if the padding provides adequate fire protection, satisfies local codes, and is functional and durable.
- Doors should be heavy-gauge security quality with a food passthrough.



An acute medical unit with mental health cells. Note the security doors and large windows into the individual cells.
(Photograph courtesy of Voorhis Robertson Justice Services.)

- A floor drain should be either in the space or just outside it. A remotely flushed drain could be beneficial.
- A shutoff valve for cell plumbing fixtures should be readily accessible to staff.

Observation

ISSUE: Constant observation of suicidal, mentally ill, or intoxicated inmates is critical.

RESPONSE: Constant observation of these cells requires an effective direct view of the space from a constantly staffed post rather than through electronic means. Electronic surveillance might provide a useful supplement to staff observation.

In designing the cells for good view, the degree to which their face is opened up with windows depends on the location of the cells in relation to a staff post. If the cells are located directly adjacent to a staff post with no dayroom or other space separating them, a smaller window is acceptable because the staff can easily go to the window and obtain a full view of the cell interior.

If cells are at some distance from a staff post or at a point remote from where passing staff will look in, it is critical to provide enough glazing in the doors and the fronts of the cells to make them sufficiently visible. Sufficient view would include the ability to see the inmate when lying on the bed or using the toilet (while providing basic privacy), and to see any spaces in which the inmate might attempt to hide.

Location

ISSUE: Cells for suicidal, mentally ill, or intoxicated inmates might best be located near or in the receiving part of the intake-release area.

RESPONSE: Suicidal, mentally ill, or intoxicated individuals can be quite difficult to

manage. Consequently, it is desirable to minimize the amount of movement involved in bringing them into the facility and reaching the proper housing area. Placement of these cells in or very near the intake-release area is very desirable. The key to location, however, is the ability to monitor the inmate constantly. Periodic observation, such as that provided by roving staff, is helpful as a supplement but is not recommended as the sole source of staff surveillance.

Space List

The types of inmates with special housing needs and the types of spaces that might be provided to meet those needs are as follows:

- Work release/periodic-sentence inmates:
 - Vestibule from jail security envelope.
 - Sleeping rooms.
 - Dayroom.
 - Shower/toilet.
 - Search areas (male/female).
 - Street clothes storage/change area.
 - Clean clothes storage/change area.
 - Laundry.
 - Secure entry.
- Inmate workers:
 - Sleeping rooms/dormitory.
 - Dayroom.
 - Shower/toilet.
- Protective custody inmates/juveniles:
 - Cells (to accommodate inmates with and without disabilities).
 - Dayroom.
 - Shower/toilet.
- Medical isolation inmates:
 - Cells.
 - Dayroom.
 - Shower.
- Disciplinary detention inmates:
 - Cells (to accommodate inmates with and without disabilities).
 - Dayroom/vestibule.
 - Shower.
- Suicidal/mentally ill/intoxicated inmates:
 - Cells (to accommodate inmates with and without disabilities).
 - Dayroom/vestibule.
 - Shower.
- Staff post.
- Storage.
- Janitor closet.

Local codes and ADA guidelines regarding accessibility requirements should be consulted when planning these spaces.

Relationships and Components

Exhibit 16-8. Relationships Between Special Housing Areas and Other Jail Areas

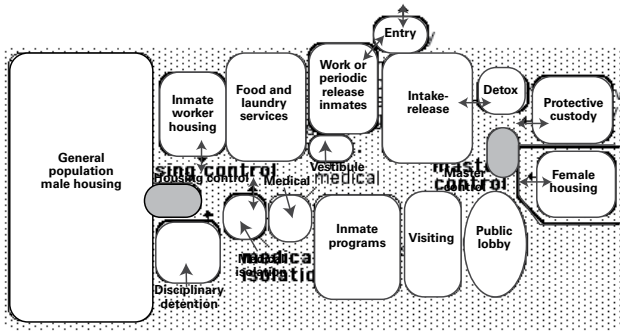

Exhibit 16-10. Components of ADA-Compliant Cell

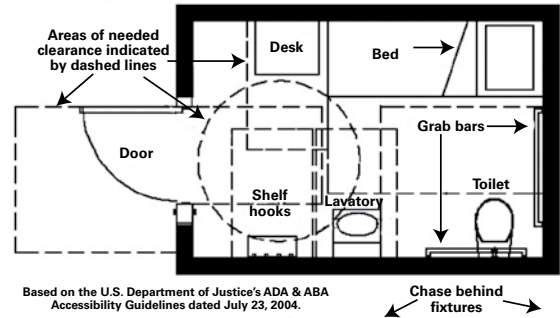

Exhibit 16-9. Components of Work Release Unit

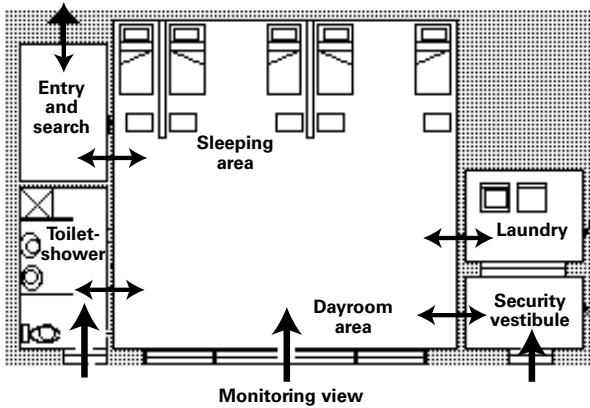
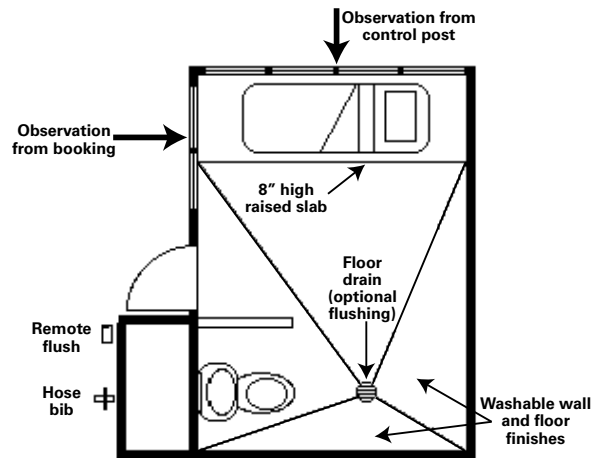

Exhibit 16-11. Components of Suicide/Mental Health/Detoxification Observation Cell



Adequate health-care services are essential to the well-being of arrestees and inmates and should be viewed as a basic human right and a basic responsibility of the jail. The purpose is not only to serve the individual's needs, but also to prevent the spread of disease within the facility. The activities necessary to carry out a complete, yet basic, health-care program typically include:

- Medical screening at intake to identify illnesses or injuries prior to admission.
- Verification of medications.
- Suicide screening at intake to identify suicide risk.
- Solicitation of inmate health complaints (sick call).
- Alcohol or drug detoxification.
- Temporary care of individuals with mental illness.
- Testing for infectious diseases (tuberculosis is the most common).
- Isolation of those with infectious diseases.
- Routine health appraisal.
- Emergency and first aid treatment.
- Administration of medicines.
- Infirmary care.
- Emergency dental care.
- Special medical diets.
- Health education.
- Mental health counseling.
- Cleaning and disinfecting of medical space.

There is considerable variety in how health care is provided in jails; that is, some jails provide health care at the facility while others take the inmate to a clinic or emergency room. Regardless of the arrangement for health care, some activities must take place at the facility and require appropriate space.

Overall, space allocations for health care in the jail need not be extravagant. If local resources are used for more costly and extensive services, space for health care might range from one area for basic examinations, first aid, medications, records, and emergency equipment to a separate space for each of those basic functions, in addition to any special housing provided. Many larger facilities provide for medical examination rooms in each housing area in an effort to reduce the movement of inmates to and from a centralized medical area.

State standards should be reviewed carefully; many of them require space for health-care services in jails. These should be checked closely. American Correctional Association standards (www.aca.org/standards/) contain an extensive list of operational and physical plant standards regarding the delivery of health-care services in local jails. The National Commission on Correctional Health Care (www.ncchc.org/) has also published standards for health care in jails and guidelines for health-care space and basic equipment. These sources provide valuable information for planning discussions.

Historically, smaller jails have suffered from an absence of proper examination or treatment space and an absence of special cells in which to house persons who have infectious diseases, are intoxicated, or may have mental health problems. For some new facilities, the



Section 3: Functional Components

space and equipment provided for examinations have remained relatively idle because jail budgets are insufficient to pay for full-time, in-house health-care staff or because service providers in the community will not come to the jail. Many health-care practitioners insist that inmates be brought to their offices or to local health-care facilities. This practice poses both security and manpower problems for jail staff. Joint planning with local service providers is essential to be able to determine appropriate space and equipment allocations between the jail and the community and to solicit proper involvement at the jail.

Key Decisions

As the role of the health-care component is evaluated, the following decisions should be made because they have a fundamental impact on design requirements:

- To what extent and how frequently will the required health-care services actually be provided?
- How many inmates will receive these services?
- Which of the required health-care services can be provided by properly trained jail employees (e.g., first aid, initial intake screening, cardiopulmonary resuscitation (CPR))?
- Which of the required services can and/or should be provided at the jail by health-care professionals (e.g., routine examinations, tests, dental care, sick call)?
- Are doctors, nurses, and dentists available to come to the jail as contract service providers, or will the jail hire in-house medical staff or contract with a medical service company specializing in providing services to detention facilities?
- What services and facilities are available and accessible in the community that do not need

to be duplicated at the jail, and what are the economic and security ramifications of using them (e.g., transportation, jail officer escorts, providing security at the community facility)?

- What level of special housing will be provided at the jail for detoxification, medical isolation, minor illnesses, or convalescence? How will these areas be supervised and how will proper medical care be provided (staff nurse, emergency medical technician)?
- How will future growth in the jail population or future changes in the makeup of the population affect the methods of delivering the various types of medical services? How will space and equipment needs be met in the future?

Detail Issues

The following discussion about detailed functional-architectural issues is limited to the typical health-care functions or spaces common to jails; a review of every issue related to health care, such as surgery, is not necessary because such services are rarely, if ever, provided in a local detention facility. Issues dealing with special housing for inmates with infectious diseases or mental health problems are addressed in chapter 16, “Special Housing.”

Examination Area

The following information applies to examination areas: activities, number of rooms, room size, work surface and access, and dental examination.

Activities

ISSUE: Identify all of the activities that will occur in the medical area.

RESPONSE: Typical activities might include the following, depending on agency desires and the availability of community resources:

- Initial screening to identify medical/mental problems and suicide risk. If this task is done by medical staff, it is often done in an examination room in the intake area.
- Response to inmate health complaints.
- Routine health assessments.
- First aid.
- Testing for infectious diseases.
- Mental health screening.
- Consultations/medical counseling.
- Emergency equipment storage.
- Minor treatment procedures (e.g., injections, topical applications, bandaging).

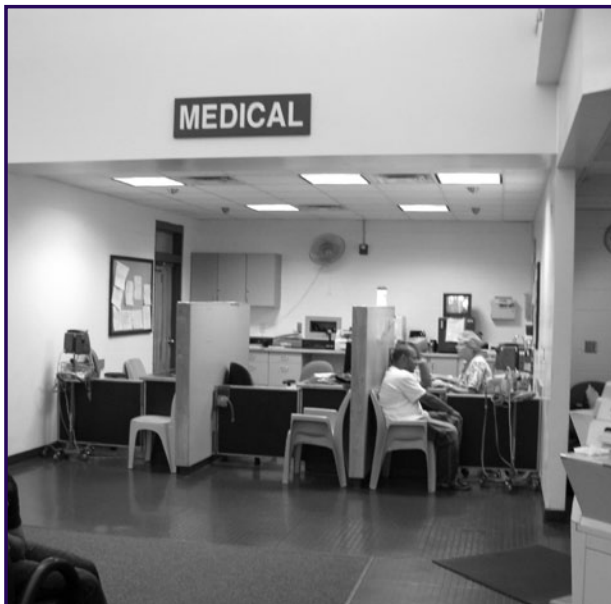

Medical screening station in the intake area of a large jail.
(Photograph courtesy of Voorhis Robertson Justice Services.)

Other possible activities include:

- Records storage.
- Records preparation and review.
- Assorted doctor/nurse office functions.
- Storage of medications.
- Minor laboratory work.
- Routine dental work (examinations, fillings, extractions).
- Minor x-ray work.
- Drug testing (e.g., taking urine specimens).

It is inappropriate to merge office and record-keeping functions with examination functions if it means that the privacy of examinations would be violated. For example, it would be inappropriate for a doctor to examine or consult with a patient while a records clerk was nearby managing medical files or talking on the telephone.

Number of examination rooms

ISSUE: The types of examination activities and the projected workload must be identified to determine the number of examination rooms needed.

RESPONSE: Many smaller jails find one examination room to be sufficient. However, in larger jails a variety of factors dictates the actual number of spaces needed:

- Significant differences in functions and equipment needs (e.g., dental versus medical examinations).
- The variety of tasks to be performed in the space, which dictates levels of use.
- The projected number of inmates who will use the space.

Section 3: Functional Components

- The actual number of hours of operation per day or week as they relate to the availability of health-care professionals.

If more than one examination room is needed, preferably the rooms should connect or at least be adjacent to each other in a designated medical area in the facility.

Room size

ISSUE: The size of examination rooms will vary with the level of care provided.

RESPONSE: A basic examination room might be defined as a space whose size is determined by the needs of basic first aid and basic physical examinations. Such a space would probably have the following equipment at a minimum:

- Examination table (with stirrups).
- Examination stool or chair, plus a chair for the inmate's use.
- Examination light.
- Countertop with sink and gooseneck faucet (foot controls for the sink are highly recommended).
- A small writing surface for the doctor or nurse.
- Computer workstation for entering medical information.
- Lockable storage cabinets and drawers.
- Scale with measuring rod and support pillar.
- Footstool.
- Trash and waste cans.
- Secure containers for biohazards and sharps.



Typical examination space and equipment.
(Photograph courtesy of Kimme & Associates.)

- Eye chart.
- Refrigerator to store specimens.

Other basic medical equipment, such as blood pressure cuffs, may or may not be mounted units. It is important to work with health-care providers to determine their functional and equipment needs.

A space as small as 80 net square feet could be adequate to meet minimum functions and equipment requirements. A space of 100 net square feet would be more comfortable and more typical of standard expectations in the field. A space of 180 net square feet or more might be required if minor emergency care and additional treatment procedures are performed (such as changing dressings or eye or ear irrigations).

Work surface and access. Two of the key variables used to determine the minimum space required for medical examinations are the need for work

surfaces and for access around the examination table. A work surface or desk is needed to allow the doctor or nurse to write a report, to hold a computer if inmates' files are computerized, and to accommodate a sink and the temporary placement of equipment and supplies that are used during the examination.

Access around the examination table can be from one side to four sides. Access on two sides is the minimum acceptable for routine examinations and first aid; access on four sides is preferred because it allows for a full range of services, including emergency medical treatment (exhibit 17-1).

Dental examinations. Many jails provide space for dental examinations and routine dental care in the facility. Dental exam spaces can range from 90 to 150 net square feet for a single examination unit. The extent of services to be provided determines the size of the space (i.e., visual examinations only, or also x-rays and dental procedures such as extracting or filling teeth)? Sample equipment includes:

- Dental chair (approximately 27 inches wide × 75 inches long reclined).
- Dental unit (drills, lights, air line, water lines, tray).

Exhibit 17-1. Access Around Examination Table

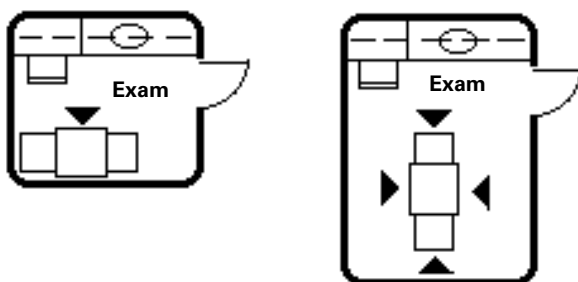

- Area for an air compressor to power the dental unit, which is outside of the examination room.
- Evacuating system.
- Lockable storage cabinets and drawers.
- Countertop and sink.
- Sterilizer.
- Waste and trash cans.
- Secure containers for biohazards and sharps.
- Stools for the dentist and assistant.
- X-ray viewer.
- X-ray machine, which also requires a protected area and lead-lined aprons.

The need for examination space will increase if both medical and dental examinations will be performed in one area. All examination rooms should be sized to allow for the greatest access

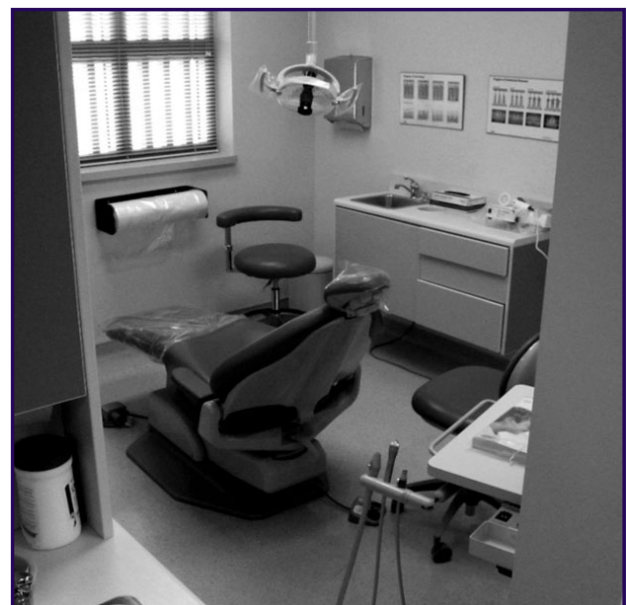

Dental examination room in jail health-care area.
(Photograph courtesy of Kimme & Associates.)

and use and should be able to accommodate a stretcher.

Location/security

ISSUE: Examination rooms should be located at an area in the jail that accommodates safety, security, and service delivery needs.

RESPONSE: Examination rooms should be located on or near a main circulation corridor to facilitate quick, easy access by inmate patients and staff, especially from the intake-release area if examination space is not available in the intake area. Normally, security staff should not have a direct view into the examination rooms for privacy reasons, but it is important for them to monitor the flow of traffic in and out of the medical area. A window that can be screened or shuttered would be appropriate to provide selective observation. In many cases, an officer will be assigned to monitor the medical area when it is in use. Often that officer will also escort the inmates to and from the area as part of his/her duties.

When direct observation of the medical area is not possible, it might be useful to equip the doors with a status indicator light that signals whether the doors are open or closed. This alerts staff to tampering, particularly at times when the area is not in use. Closed-circuit television is also a useful monitoring tool, as is an intercom system between the area and the post responsible for monitoring the area. Master control is the constantly staffed post that most likely should monitor the examination area, if electronic systems are used to monitor the area.

Security

ISSUE: The security of medical personnel in examination areas should be ensured.

RESPONSE: Health-care personnel will often be alone with inmate patients, creating the potential for exposure to violent or aggressive behavior. Although master control might monitor the door to the examination area or cameras in the medical waiting area and roving security staff may be posted outside the area, an alarm system might be necessary. The alarm system might consist of a body alarm, a panic button, or a voice-activated intercom set at decibel levels above normal conversation (so that private conversations cannot be routinely monitored). Whatever system is chosen, it is important to preserve privacy and to be able to prove that privacy was preserved.

ISSUE: Equipment and supplies in the examination area must be secured.

RESPONSE: There must be a way to securely store in lockable drawers or cabinets all of the small, detached equipment items (e.g., scissors, percussion hammers, syringes and needles) and supplies (e.g., bandages, tongue depressors) found in an examination area.

Communication

ISSUE: Two-way communications between the examination area and a constantly staffed post and to parties outside of the facility should be provided.

RESPONSE: A telephone or intercom allows the health-care provider to notify staff about the completion of examinations, request the next patient, obtain information, be alerted to an emergency, and relay any other necessary information. Telephone access to the outside allows the health-care provider to order medications and make referrals. Medical staff are often assigned a radio to

communicate with facility staff and monitor calls for medical assistance.

Environmental issues

ISSUE: The basic environmental needs of examination areas should be accommodated.

RESPONSE: Various significant environmental concerns should be accommodated in an examination area:

- Lighting should be sufficient to conduct required examinations, maintain records, and so forth. Special examination lights may not be required, depending on the nature of the examinations and the equipment requested by the health-care provider.
- Natural light is a pleasing feature in an examination room, especially if medical staff will also use this space as an office (exhibit 17-2). If natural light is provided, care must be taken to provide security as well as visual privacy.

Exhibit 17-2. Examination Room Designed for Natural Light

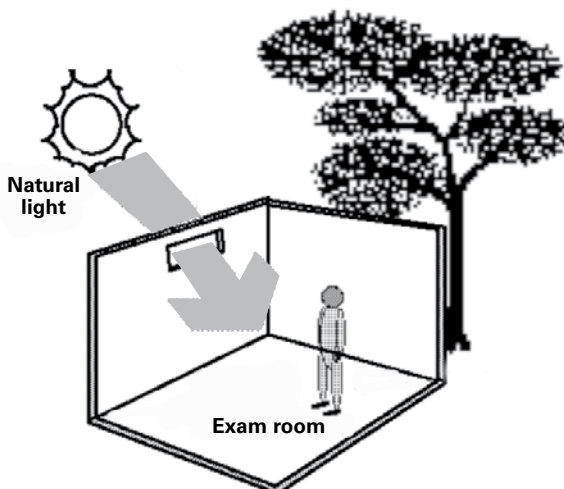

- Acoustic privacy is required so that confidential discussions about health care remain private and a professional atmosphere is created. Insulating walls and ceiling plenums, using acoustically treated hollow metal or solid-core wood doors, prevent sound travel through duct systems and can help in this regard.
- Temperature levels should be comfortable and, perhaps, controllable within the space. Ventilation should meet all required codes to ensure proper conditions and prevent recirculation of contaminated air.
- If x-rays are performed in the examination area, even on a small scale, proper precautions must be taken in the design of the room to protect health-care personnel, staff, and inmates.
- Cleanliness of the area is essential and can be enhanced by the proper selection of materials and finishes. A janitor's closet should be easily accessible for routine cleaning and occasional spills.

Medication Storage

The following functional design issues apply to the storage and distribution of medication: activities, size, location, security, and special characteristics.

Activities

ISSUE: Medication storage and distribution needs should be determined.

RESPONSE: Some of the typical activities found at jails include:

- Securely storing each inmate's prescription medicines.

Section 3: Functional Components

- Securely storing quantities of commonly used medicines.
- Securely storing medicines that need refrigeration.
- Preparing medicines for distribution.
- Distributing medicines and storing trays or carts used in distribution.
- Documenting prescription needs and distribution.
- Performing an inventory of available supplies.
- Keeping track of distribution schedules.

The actual preparation of prescriptions is a function that could, but does not typically, occur at most jails because a jail pharmacist's salary usually cannot be justified. Most often a pharmacy or hospital will fill prescriptions issued by a physician. A licensed nurse is typically responsible for dispensing the medications to the inmates. In some small facilities, the medications are distributed to the inmates by correctional staff; however, this practice is fraught with problems, including proper training and compliance with state laws.

Size

ISSUE: The size of the area needed for storage and distribution of medication will depend on the extent of the activities involved.

RESPONSE: Usually a single storage area is sufficient. The secure area used to store medication can be as small as a secure cabinet in an examination room or as large as 30 to 40 net square feet, depending on the activities required, security and operational policy, and the projected number of inmates to be served. The area's size also depends on whether it is part of the examination

Exhibit 17-3. Medication Storage Area

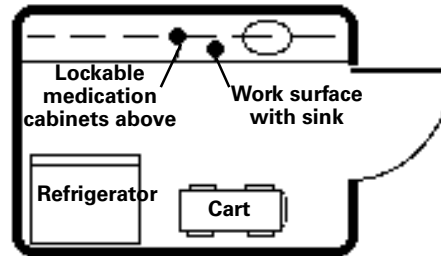

area, which would allow necessary features (such as sinks and work surfaces) to be shared rather than duplicated.

In general, this area should be well organized and have sufficient space for a countertop with a sink (exhibit 17-3). Lockable base cabinets and wall cabinets with undercabinet lighting are useful. A secure cabinet must be provided to store prescription narcotics. The medication storage area should also include a wall-mounted tack board for charts and schedules; a telephone or intercom; a lockable refrigerator for medicine, urine, and blood specimens; and a surface for report writing or documentation that may also accommodate a computer terminal.

In large jail systems, it is becoming more common to use medication dispensing machines like those used in hospitals. When medications are stored in cabinets, it may be easy to select the wrong medication or dose. Staff members may also forget to record what they select or administer. Dispensing machines often have mechanisms to help prevent these errors; for example, the machine can require that a patient identification number be entered before a medication will be dispensed. Many dispensing machines can also interface with medical computer systems to integrate their data with information from order entry systems and medication administration records. Dispensing machines can also issue alerts

and ask whether an adverse drug event has occurred whenever the machine dispenses a common reversal agent or antidote.

Location

ISSUE: The location of the medication storage area should accommodate frequent use and convenient access by authorized staff.

RESPONSE: It is important to monitor the area in which medication is stored, preferably by a direct line of sight from a constantly staffed post. This is especially important if inmates are brought to the area to receive their medications.

The relationship of the medications storage area to the inmate housing areas is important regardless of whether staff bring medications to the inmates or the inmates go to the medical area to receive their medications.

Medication storage and distribution areas generally consist of one of the following:

- A secure cabinet within the examination room.
- An enclosed medical storage and distribution space opening off the examination room.
- An enclosed medical storage and distribution space adjacent to but independent of the examination room.

This decision is based in part on a potential conflict that could occur if the examination room is being used when access to medications is required (exhibit 17-4).

In cases where daily dosages are prepared in advance during a nurse or doctor visit, a second medication storage cabinet might be provided in a secure staff post such as master control. This facilitates staff distribution of medicines while preserving the security of the main medication storage area.

Exhibit 17-4. Possible Locations of Medication Storage Area

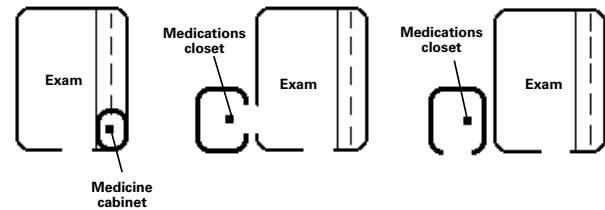

In medium and large facilities, more significant space is usually provided to facilitate medication storage and distribution and cart preparation.

Security

ISSUE: The medications storage area is available to medical or security personnel only and it must be secure from break-in.

RESPONSE: This area should have highly controlled access and be separate from other storage areas in the jail. If possible, only health-care staff, or a limited number of health-trained security staff who are expressly authorized to distribute medications when health-care personnel are absent from the facility, should have access to this area.

Some additional considerations include:

- Ensure security not only through locks and monitored security doors accessing the medications storage area, but also through the construction of fully secure walls, floors, and/or ceilings if secure walls do not extend to the roof or floor construction above.
- Secure the ductwork and any other penetrations in the area through which inmates might gain access.
- Create at least two locked barriers between the area where medications are stored and areas where inmates are frequently present.

Special characteristics

ISSUE: The contents of the medications storage area are subject to frequent inventory.

RESPONSE: Shelf design enhances the inventory process. Undercabinet and shelf lighting along with moveable (rather than rigid) shelving facilitates the organization and inventory process.

Miscellaneous Issues

The following functional-architectural issues address other elements that might be part of an examination area configuration or that might be separate health-care spaces: record storage, staff work area/offices, first aid kits, emergency equipment, toilet facilities, inmate waiting, and personal protective equipment kits. All of these elements are appropriate and are fairly common in jails.

Record storage

ISSUE: Secure medical record storage should be provided.

RESPONSE: The following considerations should guide the development of storage areas for medical records.

- Health records are confidential and should be kept secure and separate from other inmate records and under the custody of medical personnel only.
- The key to proper location of health records is that they must be accessible to health-care staff work areas and highly secured from casual access by unauthorized staff or inmates.
- Computerized medical records should be stored on a secure server in either a secured computer equipment room or off site.

Staff work area

ISSUE: A work area for health-care personnel should be provided.

RESPONSE: An area should be provided to write reports and prescriptions, complete forms, and store forms and supplies. In smaller jails where health-care personnel visit only periodically (once or twice a week), a small work area with lockable storage files is satisfactory. Lockable storage for equipment owned by health-care staff should also be accommodated. Office space separate from the examination area is desirable for full-time medical personnel in the jail or for community medical personnel who spend substantial amounts of nonexamination time at the jail. Additional considerations include:

- Separate office space should be adjacent to, but not accessible solely through, the examination space.
- If health-care personnel are available 24 hours a day and medical isolation cells are also provided, consider creating a direct-view link between the two areas.
- Work areas should have telephones with outside lines and should have an alarm system (e.g., a voice-activated intercom or panic button) if inmates are ever in the space alone with staff. Space should be provided for a computer terminal and printer to facilitate recordkeeping.
- Office space should be large enough to accommodate private consultations and record storage as well as staff needs for work surfaces and personal storage. Information about private medical or mental health counseling

areas is provided in chapter 20, “Programs and Services.”

- Work areas should have visual and acoustic privacy. However, if a partial view is desired at certain times, consider the placement of a side light in the wall of the area that can be covered by curtains or blinds when privacy is desired.

First aid kits

ISSUE: First aid kits should be available in all housing areas and control rooms.

RESPONSE: First aid kits should be standard equipment in all jails. They should be readily accessible to staff but secured from inmate access and tampering.

Medical emergency equipment

ISSUE: Storage needs for medical emergency equipment should be accommodated.

RESPONSE: In addition to first aid kits, the following medical emergency equipment is necessary for proper emergency response, in even the smallest jail:

- Wheelchair.
- Nebulizer.
- Cardiopulmonary resuscitation masks.
- Stretcher.
- Crutches and/or walkers.
- Defibrillator.
- Oxygen.
- Splints.

These items should be stored in a secure and controlled space. However, unlike areas used to store medications and medical records, the space

for emergency equipment must be easily accessible to staff on all shifts as well as to health-care personnel.

Toilet facilities

ISSUE: Toilet facilities should be available in the health-care area.

RESPONSE: Health-care staff should have access to an accessible staff toilet that is close to, but not necessarily in, the health-care area. A private, accessible inmate toilet should be located close to or in the health-care component for obtaining samples as well as for general use by inmates. In addition to separate detention-quality toilets and sink fixtures, the area should have a tamperproof mirror, soap dispenser, towel dispenser, and waste receptacle. A small shelf for samples should also be provided unless there is sufficient surface area on the sink.

Inmate waiting

ISSUE: The need for inmate waiting areas should be identified.

RESPONSE: A separate, secure inmate waiting area would be needed when groups of two or more inmates are brought to the health-care area at the same time. Waiting in groups by standing or sitting in adjacent corridors is discouraged, especially if it occurs in a high-traffic corridor or a corridor that serves as a primary means of egress. Some considerations include:

- Appropriate seating should be provided for the inmate waiting area. This area should be adjacent to the examination area and, preferably, should be visible from a constantly staffed post.
- Space for the inmate waiting area should be about 12 to 15 net square feet per person, which is adequate

Section 3: Functional Components



Waiting area in a large jail medical clinic.
(Photograph courtesy of Voorhis Robertson Justice Services.)

for both seating and for movement around the seating area.

Personal protective equipment kits

ISSUE: Personal protective equipment kits should be available.

RESPONSE: Personal protective equipment kits to protect staff from inmate body fluids should be standard equipment. These kits commonly contain plastic bags for waste that is contaminated by body fluids, disposable gloves, germicide hand cleaner, a CPR barrier, a gown, a surgical mask, and goggles. Equipment for the disposal of sharps (e.g., needles) should also be available.

Personal protective equipment kits should be located where they are readily accessible to staff but secured from inmate tampering. Lockable wall-mounted kits near intake-release and inmate housing are preferable.

Space List

Some of the typical spaces that might be found in the health-care component include:

- Examination/treatment room(s).
- Secure medications storage and distribution.
- Secure records storage.
- Staff work area (offices).
- Storage closet.
- Emergency equipment storage.
- Inmate toilet.
- Inmate waiting area.
- Dental examination room.
- Janitor's closet.
- Housing (see chapter 16, "Special Housing").

Local codes and Americans with Disabilities Act guidelines regarding accessibility requirements should be consulted when planning these spaces.

Additional health-care spaces that might be found in a jail include:

- Staff lockers.
- Treatment room (for minor surgeries or emergency treatments separate from examinations).
- Sterile storage room.
- Soiled linens workroom.
- Reception/clerical.
- X-ray room.
- Dental operating room.
- Laboratory.
- Biohazard storage.
- Clean and dirty utility storage.

Relationships and Components

Exhibit 17-5. Relationships in Health-Care Area

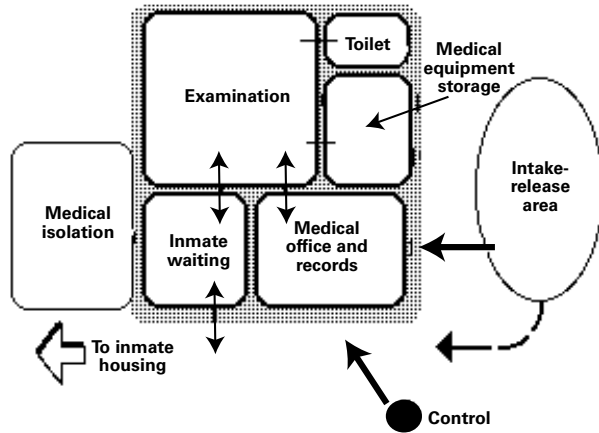
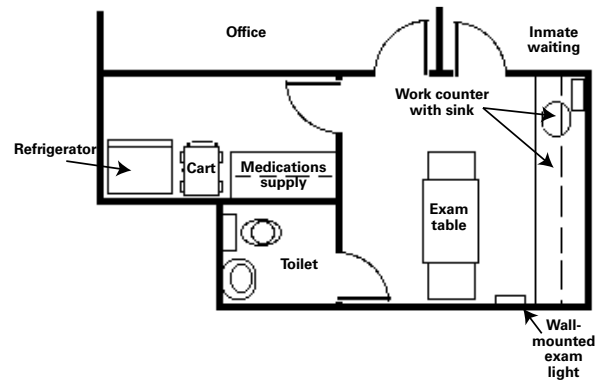

Exhibit 17-6. Component Diagram of Health-Care Area



Chapter 18

Visiting Areas

Visiting is one of the crucial links between inmates and the community. It provides a way for inmates to communicate (other than by telephone or mail) with family, friends, and other community members, such as attorneys and clergy members from outside the jail. Visiting is extremely important to inmates because it enables them to keep in touch with family members, friends, business associates, ministers, and attorneys. Because visiting is so important to inmates, it is one of the jail's most effective tools in managing their behavior.

In older jails, visiting commonly occurred in the cellblocks rather than in areas set aside specifically for visiting. These cellblock areas were characterized by a complete lack of privacy; physical conditions dangerous for staff, visitors, and inmates; and poor security features. Visitors and inmates had to stand, view each other through tiny vision ports, and strain to speak and be heard through heavily meshed “voice boxes” in spaces with very poor acoustic qualities. The introduction of contraband was a significant problem given the visiting area's location within the security envelope.

In modern jails, visits with friends and family usually occur in private, noncontact spaces where physical comfort and limited privacy are better afforded. These design improvements reflect case law that has condemned the lack of quality visiting space and conditions.

Recently, the use of “video” visitation has become more common—the visitor communicates with the inmate via a video monitor located either in the jail lobby or at another location. The inmate has access to visitors using a booth located most often in the housing area or at another location within the secure perimeter. The advantage to video visitation is that it eliminates any

possibility of passing contraband and reduces the security required for inmate visitation. The cost of installing a video visitation system is often offset by the decrease in staff costs associated with visiting (i.e., screening visitors, moving inmates to a centrally located visiting area, supervising visits).

Contact visiting tends to be limited to attorneys, counselors, and other “professional” visitors; contact visits with family, when permitted, are usually limited to low-security inmates such as inmate workers or others during special occasions at the discretion of jail officials. In some jurisdictions, contact visiting is accommodated in multipurpose rooms and outdoor recreation yards.

A variety of spaces are needed for visiting, including:

- Space for both noncontact and contact visiting for both personal and professional visitors.



Video visitation stations for the public.
(Photograph courtesy of Liebert & Associates.)



Outdoor area used for family contact visits at a minimum-security facility. (Photograph courtesy of Voorhis Robertson Justice Services.)

- Visiting facilities that accommodate inmates and visitors who have disabilities.
- A visitor reception desk or area in or adjacent to the public lobby.
- A visitor waiting area that has public restrooms, a telephone, and a drinking fountain.
- A storage area for visitors' personal property that is prohibited from visiting areas (essential for contact visiting).
- An area in which to search inmates in privacy following their visit (essential for contact visiting).
- An area for occasional searches of visitors suspected of carrying contraband.

Courts have generally held that inmates should be allowed to visit with family, friends, religious advisers, prospective employers, and the news media within a reasonable jail schedule. Virtually all states and national agencies with jail standards require and address the provision of visiting opportunities and facilities. Planners should

check applicable state standards for mandatory requirements.

Key Decisions

As the role of the visiting component is evaluated, the following decisions will have a fundamental effect on design requirements:

- How much space should be provided for visiting? How many inmates will be able to visit at the same time and how many visitors will be allowed to visit with each inmate? How long will visits last? How much access to visiting is required by standards?
- Will visitors move to a visiting area located next to inmate living areas or will inmates move to a central visiting area located near the public entry?
- Will inmates be allowed to have contact visits with family or lawyers and, if so, which classifications of inmates will be allowed to do so? How will staff be made available for intensive screening of visitors and searches of inmates? Will space be dedicated for contact visiting or will some other space (such as a multipurpose room) be used?
- Will inmates and visitors communicate over a telephone or more directly (e.g., via a sound port)?
- Will video visiting technologies be used to either replace or supplement certain forms of visiting? If so, how will it work and where will it be done?
- Which staff post will supervise the visiting area? How will inmate movement to visiting areas be monitored?
- Where will visitors be received? Who will receive them? How will packages, money, and other items that visitors bring to inmates be processed?

Detail Issues

The following detailed functional-architectural issues should be considered in the development of the visiting component: activities, the size of spaces, the number of visiting stations, location/movement, security, and quality.

Activities

ISSUE: It must be determined how basic visiting activities will be accommodated, which staff member will conduct or supervise them, and where they will take place.

RESPONSE: The following activities usually pertain to visiting:

- The visitor arrives and is registered and screened for security (person and materials) by staff. It is common to prohibit visitors from bringing items (e.g., purses, diaper bags, heavy coats) into visiting. Attorneys are often allowed to bring in legal paperwork, which must be searched. Often, there are limits on briefcases and the amount of paperwork that is allowed.
- Staff determines which inmate the visitor desires to see and whether the visit will be allowed.
- The visitor is directed to the waiting area and is informed about rules and length of visits.
- The visitor stores personal property (e.g., coats, hats, purses) in the locker area.
- Staff determines where the inmate is and either communicates with other staff, who will escort the inmate to the visiting area, or escorts the inmate personally (assuming visiting is centralized).

- The inmate and visitor are escorted to the visiting booth or room after the visitor is scanned by a metal detector and perhaps pat searched if it is a contact visit.
- Staff supervises the visit, ensuring that behavior is acceptable and within rules (especially important with contact visiting and official interviews).
- Staff informs parties that the visit is over or responds to their request to end the visit.
- Staff observes the inmate's return to the housing area (he or she may be subject to some form of search) and the visitor returns to the waiting area.
- The visitor is checked out and any stored property is returned.

Size of Spaces

ISSUE: The size of visiting spaces is determined by the number of users and by comfort and security considerations.

RESPONSE: The size of noncontact visiting spaces is determined by the following considerations:

- Spaces should be wide enough to comfortably accommodate more than one visitor and one inmate at the same time. If no information is available to determine a proportion, design at least half of the noncontact spaces as double stations to accommodate two visitors (exhibit 18-1).
- Spaces should be deep enough to allow visitors to:
 - Sit rather than stand (chairs should be provided).

Exhibit 18-1. Single and Double Visiting Stations

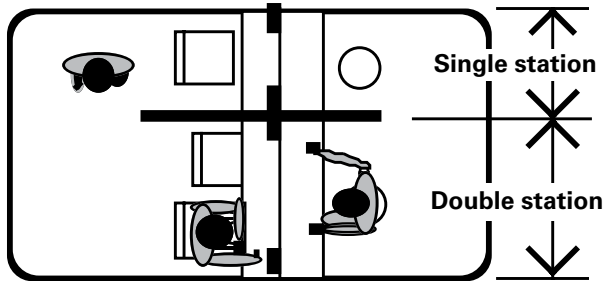

- ❑ Have adequate privacy screening on either side of the space (without screening staff's view).
- ❑ Move comfortably around and behind the space (especially if moveable chairs are used).

It is recommended that the depth of the visiting area be sufficient to accommodate a small counter surface for leaning or writing.

- Determine whether each individual visiting station is a fully enclosed space or if it shares space with a series of other visiting stations. If an enclosed space is chosen for greater privacy and control, allow extra space because these enclosures can feel quite confining. Allow for movement into and out of chairs and for door swings (the inmate side should swing out, if possible).
- The dimensions should be sufficient to allow access by inmates or visitors with disabilities, particularly those in wheelchairs. Flexibility in seating is important to consider as well. If security seating is generally preferred, consider detention-quality swing-out seating to allow wheelchair access.

Contact visiting spaces should be sized based on the number of users and types of activities. For contact with professional visitors, spaces should be fully enclosed and private, if possible. In most



Open-backed visiting stations within one large enclosed visiting room, all with good visibility and easy accessibility. (Photograph courtesy of Liebert & Associates.)

cases, two users are involved: the inmate and the visitor (lawyer, bondsperson, counselor). A desk surface and chairs are also required.

Occasionally more than one visitor may be involved in a contact visit with an inmate. If this possibility exists, at least one area of sufficient size should be available to accommodate this circumstance.

The jail administration may want to consider allowing contact visits to occur in a multipurpose room with different visiting groups sharing the space at the same time. This is more common in minimum-security housing areas. In this case, the space should be large enough to allow sufficient distance between the groups to retain some degree of privacy. Large numbers of people generate enough sound to mask each other's conversations (as occurs in a restaurant).

For security reasons, primarily concerning passage of contraband, it is recommended that contact visiting not occur in inmate program and service areas such as a multipurpose room. (See

chapter 20, “Programs and Services,” for further discussion on this topic.)

ISSUE: Visitor waiting areas must be sized appropriately.

RESPONSE: The size of the visitor waiting areas should be determined based on the following considerations:

- Visitors usually wait in the public lobby. If the building serves law enforcement, courts, and other functions, the total lobby area should be large enough to accommodate waiting visitors. However, if the lobby is restricted to jail functions or if jail visitors wait in a space separate from the public lobby, that space should provide at least 15 square feet per person (preferably 20 square feet to allow for adequate circulation).
- The number of expected visitors must be determined, which largely depends on how visiting is administered at the jail. In jails that offer open visiting (i.e., unscheduled visiting that is done on a “first come, first served” basis), the maximum number of visitors must be determined and the space designed accordingly. Ideally, visiting is scheduled so that the number of visitors in the area at any one time can be predicted accurately. For example, if the jail can accommodate 10 visits at one time, allows half-hour visits, and provides 2 hours of visiting time per day, jail staff could expect to have no more than 10 to 20 people waiting at one time to accommodate 40 total visits in a scheduled situation (based on 1 or 2 visitors per inmate visit). However, in an unscheduled situation, it is possible that 40 to 80 visitors (1 or 2

visitors per inmate) could arrive at the jail at the same time, thus requiring substantially more square footage in the lobby/waiting area.

- Waiting areas should also provide space for visitor lockers. The amount of space required for the lockers depends on the number of lockers needed, which in turn is dependent on:
 - The number of visitors in the facility at any one time who need lockers.
 - The amount of items to be stored in the lockers.
 - The size of each locker.

Lockers do not need to be in a separate space. They can be part of the visitor waiting area or in an alcove just off the waiting area. Locker size depends on the items to be stored (normally coats, hats, purses, and briefcases) and the manner in which articles of clothing are to be stored (folded or on hangers). Visitor lockers should not be confused with the secure weapons storage lockers required at all ingress points to the facility. (More information about lockers is given later in this chapter).

The inmate waiting area is another consideration. It may be desirable to have a waiting area for those inmates who are ready to move into the visiting space during the next visiting period. This area might be a separate room or a small alcove located near an access corridor. It should be under direct staff surveillance or supervision because inmates of different classifications may be waiting at the same time. If this occurs, it may be prudent to provide separate or segmented waiting areas (all observable from a single point).

Other elements related to the public lobby (such as toilets, telephones, and drinking fountains) should be accessible from the waiting area/lobby,

as discussed in chapter 24, “Administration and Public Areas.” All elements should be accessible to persons with disabilities.

Number of Visiting Stations

ISSUE: The number of separate visiting stations needed depends on the projected number of visitors and on how visitors will be scheduled.

RESPONSE: To determine the number of visiting stations, the following factors must be considered:

- How many visits each inmate will have per week, on average.
- How long each visit will be, on average or at minimum.
- How many hours will be set aside per week for visiting (e.g., Monday, Wednesday, and Friday, 5 p.m. to 8 p.m., and Saturday and Sunday, noon to 5 p.m., would total 19 hours per week).
- Visitation needs when the jail population is at a peak (occasionally beyond design capacity).

Following are some assumptions regarding the factors that affect space needs for fully occupied jails. These factors are then applied to a sample formula that shows how to calculate the number of stations needed (exhibit 18-2).

The formula used to calculate the number of stations is:

$$\frac{\text{Number of stations}}{\text{total weekly visiting hours available}} = \frac{\text{total visits} \times \text{length of visit} \times \text{peak factor}}{\text{total weekly visiting hours available}}$$

Exhibit 18-2. Sample Visiting Assumptions

Assumption	60-Bed Jail	150-Bed Jail
Visits per inmate each week (average)	1.5	1.5
Total visits each week	90	225
Average length of visit (hours)	1	1
Total weekly visiting hours available	19	19
Peak factor (for irregularity in visiting patterns)	1.6	1.5

For the 60-bed jail example above, the formula works out as:

$$\frac{\text{Number of stations} = 90 \times 1.0 \times 1.6 = 7.57}{19 \text{ hours}} \text{ (or 8) stations}$$

These calculations should be done separately for both contact and noncontact visiting.

Location/Movement

ISSUE: The method selected for providing inmate and public access to visiting areas can greatly influence facility design.

RESPONSE: In general, there are two basic arrangements for a noncontact visit between an inmate and a visitor. Each has a major impact on design:

- Moving the inmate to the visitor (customary). This usually requires significant staff time because inmates must be taken from their living areas to a visiting area near the public lobby, unless movement can be achieved without escort by properly locating staff posts and/or closed-circuit television cameras (exhibit 18-3).
- Moving the visitor to the inmate. This is done via a separate circulation corridor from the public lobby to visiting stations outside of, but adjacent to, inmate housing. Inmates enter the visiting booth directly from their day-room without staff escort. In favorable circumstances, visitors can also move unescorted through separate visitor corridors to minimize demands on staff.

Accommodating visitors at the housing units presents problems because the visitor must move deep into the facility, although outside the secure envelop of the housing areas, to reach the housing units. There are two key considerations with this concept:

- A second, totally secure visitor corridor must be created to ensure that the jail's security envelope is not violated. This is frequently

achieved by constructing a second corridor above the primary inmate corridor (exhibit 18-4). There are no penetrations in this corridor that allow access to inmate areas. Egress from this corridor should be down a secure, dedicated elevator or set of stairs or through a secure exit that does not involve the security envelope of the jail.

- The visiting areas at the housing unit must provide sight and sound privacy but allow for the officer in the housing area to supervise the area.

For the small jail in particular, this approach to visiting must be closely evaluated. It could create unnecessary expense and complications because moving inmates to a central visiting area does not normally involve great distances or many people at one time. Therefore, this idea does not offer the time, movement, and staff-saving elements that make the concept attractive to medium and large jails.



Video visiting

Visiting using video equipment (cameras and monitors) changes the discussion of location considerably. Installation of a video visiting system essentially allows the public visitor to stay in or near the lobby or even at a remote location and it

Exhibit 18-3. Moving the Inmate to the Visitor

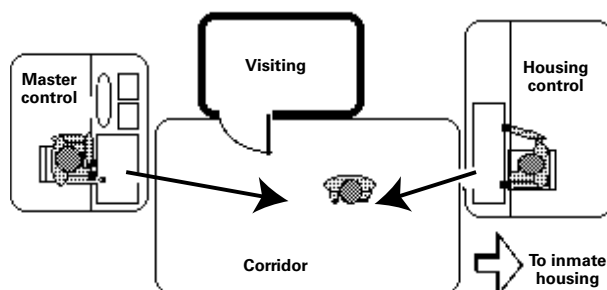
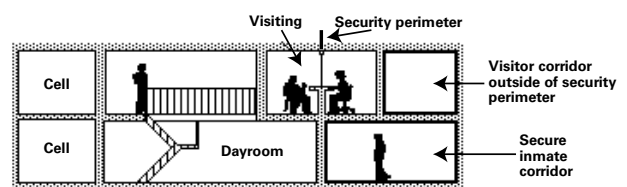

Exhibit 18-4. Secure Visitor Corridor Constructed Above the Primary Inmate Corridor



allows the inmate to stay in or near the housing unit. This method negates concerns about security and passage of contraband that are usually associated with visiting.

The use of video, however, does not negate the need to create private visiting stations for the inmate and the visitor. In addition, it creates the need for designs that protect the equipment at both locations while allowing for easy maintenance. Nonetheless, staff time and effort can be saved due to reduced inmate movement, security searches, and staff surveillance.

In assessing the appropriateness of video visiting, local laws and statutes must be taken into account and fears of illegal monitoring must be addressed, although it is often allowable to monitor or record nonprofessional visits. The quality of the visit must also be evaluated in terms of its consistency with the facility's mission and its effectiveness in satisfying programmatic and behavior management goals.

Arrestee visiting

The visiting access needs of arrestees in the intake-release area should also be considered. An arrestee may need to consult with family members or a bondsperson about release arrangements. One response might be to place a visiting station in the intake-release area. Such a space should:

- Have a controllable access point for the visitor, especially if access is directly from outside.
- Be noncontact, constructed with security partitions, security ceilings and floors, security glazing and framing, and a secure means of communication.
- Be monitored by staff.
- Have a secure paper pass for obtaining signatures on papers, if appropriate to the operational policy.



Visitors checking in for video visits in a large outdoor waiting area.
(Photograph courtesy of Voorhis Robertson Justice Services.)

Security

ISSUE: Certain safeguards must be implemented to maintain security and prevent the passage of contraband during visitation.

RESPONSE: The following considerations help provide adequate security for the visiting component:

- All visitors should be required to pass through a metal detector to screen for weapons prior to entering the jail's visiting area. This typically requires a staff member to be posted at the point of access to the visiting area to operate the machine, but this position can often double as the reception point. This position should be supported by direct visual monitoring from a constantly staffed post, such as master control.
- All nonprofessional visitors who participate in contact or noncontact visiting will normally be required to place all personal belongings and outer garments in a locked storage space in the

public lobby. Lockers might be operated using a coin, token, or key, depending on whether jail staff have control over them. If staff control the use of the lockers, planners must decide who will issue the token or key and how issuance and return will be accomplished. If coins are used to access the lockers, planners must decide if the coin will be returned or kept to offset the costs of maintaining the lockers.

- An area should be designated to search inmates privately, particularly after contact visits.
- Signs should be posted that alert visitors to the fact that they are subject to search if there is reasonable belief that they threaten staff, inmate, or public safety.
- Signs should be posted in the public lobby to inform the public about rules and regulations for visiting (e.g., length of visit, acceptable behavior, proper attire) and the sanctions for violation of the rules.
- Access to visiting should be through a security vestibule controlled by staff, rather than directly from the waiting area/lobby (exhibit 18-5).
- Staff should be posted so they can visually monitor the visiting area and the security vestibule.
- A means of communication should be provided for staff to speak to visitors and inmates in facility designs where the supervising officer is posted outside the visiting area. Communications are needed to correct misbehavior as well as to announce the beginning and end of visiting periods.

Exhibit 18-5. Security Vestibule in Visiting Area

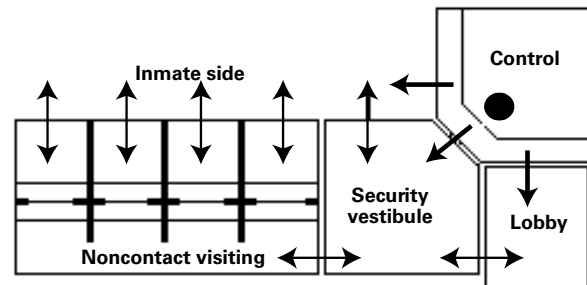

- A means of communication by which visitors can voluntarily speak to supervising staff should be considered. It should be physically activated by the visitor rather than voice activated to avoid accusations of unauthorized monitoring and privacy violations.
- The wall separating the visitor and the inmate should be part of a defined internal security zone (if not the main security envelope) that precludes penetration. This includes the vision panel, panel framing, and the communication device used if it forms part of the wall's security. The ceiling and floor elements that help form the zone also should be constructed securely.

Quality

ISSUE: The quality of the visiting area is important in responding to the needs of both the visitor and the inmate.

RESPONSE: There are a variety of ways in which the integrity and quality of the visit can be reinforced in design.

- Communication between the visitor and the inmate in noncontact visiting must be of good quality (sufficiently loud and clear). The best way to

achieve good sound quality is to use telephones. Two telephones should be provided on the visitor side of two-person stations. Communication through the window frame (as offered by some detention equipment manufacturers) is also an option. Perforations in the top of the sill of the window frame have been used successfully for communication purposes. The key to this approach is to provide enough perforations to allow satisfactory sound transfer but to ensure that no contraband can be passed through them.

- Acoustic treatment of the space should allow for sound levels that permit privacy and conversation without raising one's voice. Sound transfer from neighboring visiting areas should be minimized and, if possible, excluded through the provision of generous amounts of sound-absorbing material. Acoustics within fully enclosed individual noncontact spaces can be of poor quality (sound reverberation) unless sound-absorbing materials are provided.
- Noncontact visiting booths should provide ample space for comfort and include a counter surface for writing or leaning.
- In noncontact visiting stations, the inmate and visitor should be able to see each other comfortably by means of a fairly large security-glazed window. This not only enhances the view but makes the otherwise small visiting spaces seem larger. Facilities should determine whether visitors will be seated, standing, or both, although it

is recommended that there be a sufficient number of chairs available for the maximum number of visitors, excluding lap children.

- Natural light is beneficial to the quality and openness of the visiting area.

Space List

Some of the typical spaces that might be found within the visiting component include:

- Reception desk/counter/space.
- Public waiting area.
- Locker storage.
- Secure entry vestibule.
- Public search area.
- Inmate search area.
- Noncontact visiting area:
 - One-visitor station.
 - Two-visitor station.
- Contact visiting area:
 - Space for one-on-one visits.
 - Space for visits that include a number of people (e.g., hearings).

Local codes and Americans with Disabilities Act guidelines regarding accessibility requirements should be consulted when planning these spaces.

Other closely affiliated or space-sharing areas include:

- Public lobby/night lobby.
- Public toilet areas.
- Intake-release area.

Relationships and Components

Exhibit 18-6. Relationships Between Visiting Area and Other Jail Areas

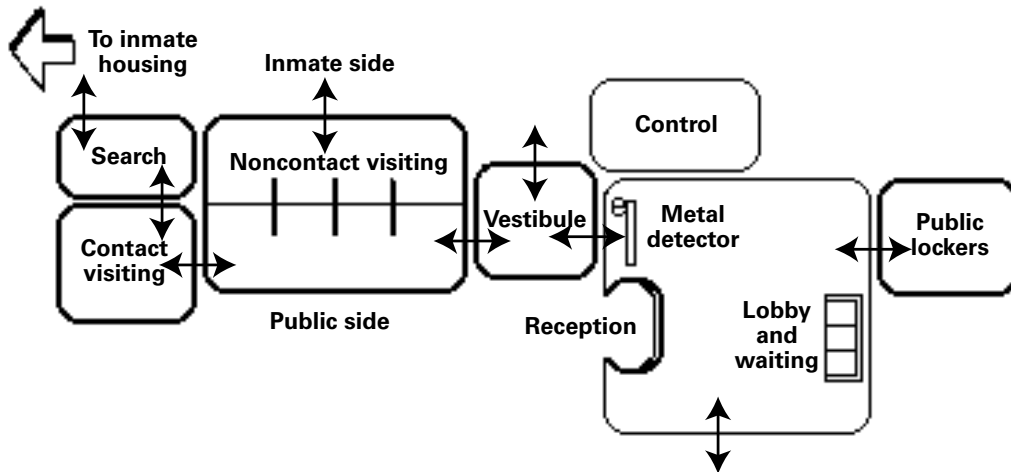
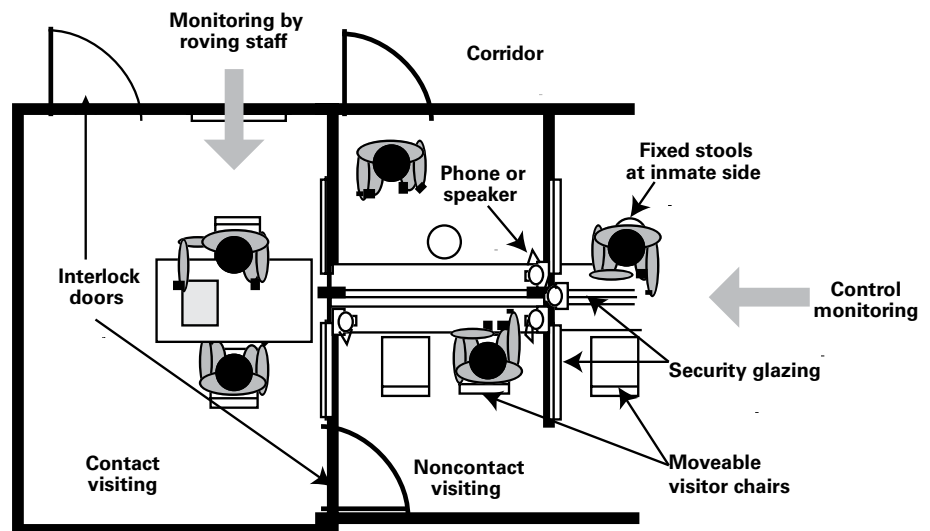

Exhibit 18-7. Components of Visiting Areas



Active indoor and outdoor exercise outside the housing units is important to the physical and mental well-being of inmates and to facility security because it provides a positive outlet for inmate energy. Outdoor exercise is thought to be especially beneficial to both emotional and physical well-being because of exposure to fresh air and sunlight and because it provides a temporary release from confinement within the building.

The most typical kinds of active exercise found in jails are:

- Basketball.
- Volleyball.
- Handball.
- Walking.
- Weightlifting.
- Calisthenics.

In the past, many jails did not provide both indoor and outdoor exercise areas. In those that provided neither, exercise was limited to individual efforts to do calisthenics in cells or dayrooms. In older jails where crowding has become a serious issue, indoor recreation areas such as gymnasiums have been converted to housing areas with the addition of bunks, eliminating the use of the area for exercise.

The provision of indoor and outdoor exercise areas in new jails has generally become an expected practice. Organized recreational programs that involve trained recreational staff, competition, and training are becoming more common in larger jails, but often cannot be accommodated in smaller jails.

Outdoor exercise differs from indoor recreation in that it features very physical and vigorous activities that require special space and equipment. Indoor recreation is addressed in chapter 20, “Programs and Services.”

Jail administrators report that the availability of indoor and outdoor exercise areas is associated with fewer operational problems such as inmate-on-inmate assaults, inmate assaults on staff, damage to jail property, and lawsuits. These benefits are in addition to the health and psychological benefits for inmates.

Key Decisions

The following decisions should be made when evaluating the role of the exercise component, as they have a fundamental effect on design requirements:

- Will both outdoor and indoor exercise space be provided or only one or the other? Will an indoor/outdoor exercise area with large windows that open for light and ventilation or a retractable, mesh-covered roof be provided, instead of two separate exercise areas?
- Will indoor exercise areas be provided outside the inmate housing units, or will special exercise areas be incorporated into the housing units? If exercise areas are outside, will the areas be adjacent to the housing units or will there be one central exercise area for all male and female inmates (general and special housing)?
- Will groups of inmates be mixed to some degree, or will they exercise separately according to housing unit group? If the former, what will be the makeup and size of each mixed exercise group?

- Who will monitor the exercise activity and how?
- If outdoor exercise space is provided, should it double as emergency evacuation space?
- Should exercise areas be sufficient in size and number to accommodate a future expanded inmate capacity?

Detail Issues

This chapter examines the general functional-architectural issues that pertain to the development of exercise areas as well as specific issues related to combination indoor and outdoor exercise areas, indoor exercise areas, and outdoor exercise areas.

General Issues

The following issues apply to both indoor and outdoor exercise: users, size, number of areas, support space, movement and control, and communication.

Users

ISSUE: The numbers and types of people to use exercise areas should be determined.

RESPONSE: There are two principal types of potential users:

- Inmates.
- Law enforcement or jail officers, as part of their fitness or community involvement programs.

When designing centralized exercise areas it is important to identify the number of inmate groups that must exercise at separate times because of classification and supervision concerns. These groupings should respect the basic classification/separation requirements of the facility unless the level of staff supervision for

exercise is sufficiently high to allow some merging of groups housed separately.

Once the number and types of groups are identified, the maximum group size should be determined, because that size will influence space and equipment requirements as well as staffing needs. The possibility for capacity expansion should also be identified to determine whether a larger group might someday need to be accommodated or whether additional exercise spaces should be planned.

Size

ISSUE: The size of exercise areas should be based on activities and group sizes.

RESPONSE: Activities should be chosen on the basis of what is most useful and productive for the inmates and the staff alike. Different activities require different amounts of space. For example, a small half-court basketball area would require 1,600–2,688 net square feet (regulation high school dimensions) with a ceiling height of 15–20 feet, whereas a calisthenics area might require only about 300 net square feet and a 9-foot ceiling height for the same number of users.

Additionally, each space may have secondary areas to accommodate other activities concurrently (e.g., weightlifting and basketball). Seating areas may be provided for those who are resting between activities, awaiting an opportunity to participate, or, in the case of outdoor exercise areas, merely enjoying the fresh air.

The number of people to use an exercise area at any one time clearly affects space size. Twelve people playing two 3-on-3 games of basketball, for instance, would require two half-court areas at about 3,100–5,040 net square feet total. However, eight people playing one 4-on-4 game need only about 1,600–2,688 net square feet, not

counting secondary areas for sitting, weightlifting, or other activities (exhibit 19-1).

Number of areas

ISSUE: The number of separate exercise areas needed depends on scheduling, staffing, and the number of different exercise groups.

RESPONSE: While larger jails have multiple exercise areas, smaller jails may need only one indoor and one outdoor exercise area or one combination area. However, the number of exercise areas that will be needed in a given facility cannot be known with certainty until a variety of factors are considered. Additionally, space-sharing options with other functions cannot be ascertained until all factors about exercise area use are considered.

Scheduling is a major determinant regarding the number of areas:

- **Frequency:** how often inmates will exercise outside the housing area—once a week? 3 days

a week? 5 days a week? Every day? This is often dependent on the organization’s philosophy regarding inmate management and standards requirements regarding exercise.

- **Duration:** the length of time per exercise period, including movement time between housing and exercise areas, if the exercise area is not attached to the housing unit—30 minutes? 1 hour? 2 hours?
- **Hours of operation:** the number of hours per day the exercise area is available for use. This is frequently limited by other basic activities, such as food service and visiting, that absorb staff and inmate time during the day.
- **Weather conditions:** the number of days per year that weather would typically prohibit use of an outdoor exercise area might influence the size and type of space for the indoor area.

Staffing is a major consideration, particularly when staff must be retained to supervise the exercise activity. The need or desire to minimize staffing can limit the hours available for exercise.

Exhibit 19-1. Sample Exercise Space Needs

Basketball (half-court; high school)	48 x 56 (15 feet high)	10
Weightlifting (weight machine)	12 x 16 (8 feet high)	4-6



Indoor exercise area with weightlifting and cardiovascular equipment. (Photograph courtesy of Jim Rowenhorst.)

Section 3: Functional Components

The number of different groups that need to exercise is critical because both smaller and larger jails can easily generate 8 to 12 different groups if there is a strict adherence to housing unit separation.

Support space

ISSUE: Space should be provided for staff who supervise exercise activities.

RESPONSE: Staff can be accommodated in several ways:

- An enclosed or open-counter control post immediately adjacent to, but separate from, the exercise area. This is common in direct supervision housing where the exercise area is attached to the housing area, often with windows separating the two areas.
- An enclosed or open-counter post in visual contact with, but separate from, the exercise area and also monitoring other areas such as housing.
- An open post within the exercise area sufficient to allow staff to observe without getting in the way of activity.

In providing staff space, it is important to give the officer a communication link to master control (assuming that master control does not observe exercise). Backup monitoring by closed-circuit television (CCTV) may be useful to ensure the safety of the officer, especially when the officer is within the space directly supervising the inmates.

ISSUE: Equipment storage should be provided.

RESPONSE: A lockable area adjacent to the exercise area allows for the secure storage of exercise and maintenance equipment: basketballs, handballs, volleyballs, volleyball nets, weights, brooms, hoses, etc. Smaller

items may be stored in cabinet space at the control post that monitors exercise.

ISSUE: The design should consider basic human needs.

RESPONSE: Depending on the duration of each exercise period, it may be appropriate to provide a drinking fountain and a restroom for centralized exercise areas. Such amenities in outdoor exercise areas must be protected against freezing conditions in colder locations. Restrooms should be designed to provide privacy as well as appropriate monitoring and control.

Shower and/or locker areas are typically not necessary for inmates since they can use the facilities in their housing unit. If staff are to use the exercise area, the location of any such facilities for them should be considered in light of access to the exercise area.

ISSUE: Office space for professional exercise/recreation staff should be considered.

RESPONSE: If the jail is large enough to support formal exercise and recreation programs requiring professional staff, office space should be considered. Such space should be close to the exercise areas to allow some supervision capability.

Movement and control

Classification and separation criteria should be evaluated when developing the movement and control scheme to prevent unwanted contact among different inmate groups.

ISSUE: Determine how inmates will gain access to exercise areas and how they will be monitored.

RESPONSE: Some movement and surveillance concepts follow.

- Have one large central location to which all inmates are moved and subsequently monitored by staff assigned to that area (exhibit 19-2).
- Have inmates move to one large location monitored by a constantly staffed post that also monitors other areas such as housing (e.g., master control or housing control) (exhibit 19-3).
- Create exercise areas immediately adjacent to each housing unit or cluster to be monitored by a constantly staffed post that also monitors other areas such as housing, thus eliminating movement of inmates through corridors to exercise areas and maximizing use of a fixed staff post (exhibit 19-4).

A benefit of placing outdoor exercise areas adjacent to housing units is that they can securely introduce natural light into dayrooms (and potentially cells) and serve as directly accessible temporary containment areas in case of an emergency. Another benefit is increased accessibility to the area by the inmates, thereby increasing the number of hours each inmate is allocated for exercise.

Exhibit 19-2. Centrally Located Exercise Yard

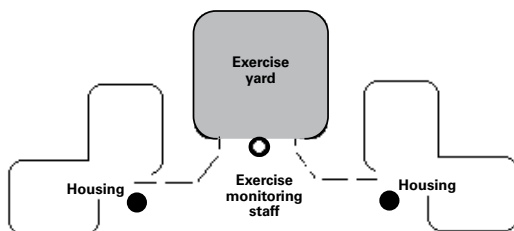

Exhibit 19-3. Exercise Area Monitored by Staff Who Monitor Other Areas

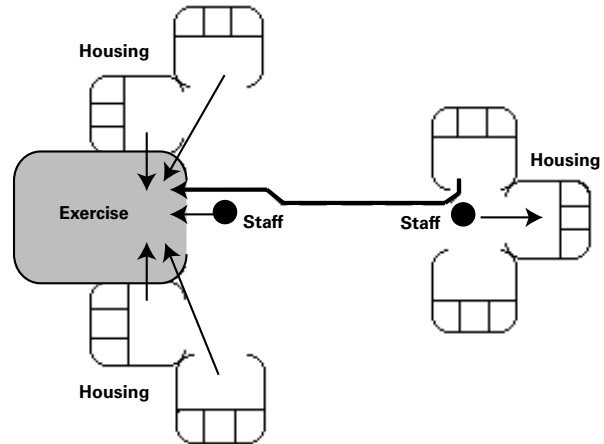
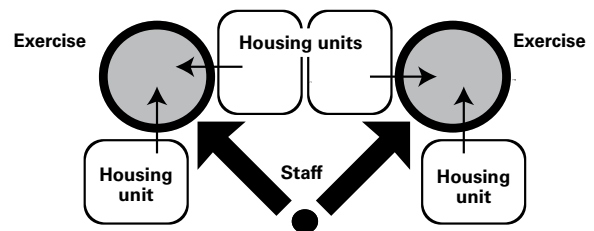

Exhibit 19-4. Exercise Areas Immediately Adjacent to Housing Units



Communication

ISSUE: There should be a means of communication between staff and inmates when they are in the exercise area.

RESPONSE: Roving security and/or control post staff must be able to communicate with the inmates and staff in the exercise area. Depending on staff location and roles, the following methods might be considered to communicate with inmates when staff are not present in the exercise area:

Section 3: Functional Components

- Intercom.
- Public address speaker.
- Direct voice communication through an opening in the exercise wall.

ISSUE: Minimizing opportunities for vandalism and damage.

RESPONSE: Light fixtures, vent grills, drain covers, and other details in both indoor and outdoor exercise areas should be handled in the same secure and protected manner as they would be within housing units.

Combination Indoor and Outdoor Exercise

ISSUE: A single space that functions as both an indoor and outdoor exercise area can be a prudent choice for some jurisdictions.

RESPONSE: In some jurisdictions, it is allowable to create a single, specially designed space that simultaneously meets standards for indoor and outdoor exercise. Combining these functions can be a less costly and more space-efficient way of providing both capabilities. It may also mean a greater likelihood that both capabilities will be made available to inmates in smaller jails, as it is easier to design one large space manageable from a fixed staff post than it is to design two such spaces.

Climate is also a motivator for the dual-use concept. In cold northern climates, providing a large outdoor exercise area, with expensive high walls, costly structure and screening overhead, and perhaps a second dedicated staff post is difficult to justify when periods of use are limited. In climates with long rainy seasons, an outdoor exercise area becomes useless for extended periods.

The primary method of creating the dual capability exercise area is to create a large opening

in one or more walls of an indoor space and to superimpose a moveable window or rollup shutter over the opening. With this technique, fresh air can be provided to inmates once the window/shutter is opened, thus satisfying the technical definition of “outdoor” exercise.

Other design considerations include the following:

- The openings must be covered by a protective screen that prevents escape and precludes contraband passage.
- The space should be tall (15–20 feet high) so that openings can (1) be large enough to allow significant fresh air movement and (2) have a sill height considerably above inmate head height so as to minimize outside view conflicts with the public.
- The openings should be oriented to allow the introduction of sunlight, and/or skylights should be provided.

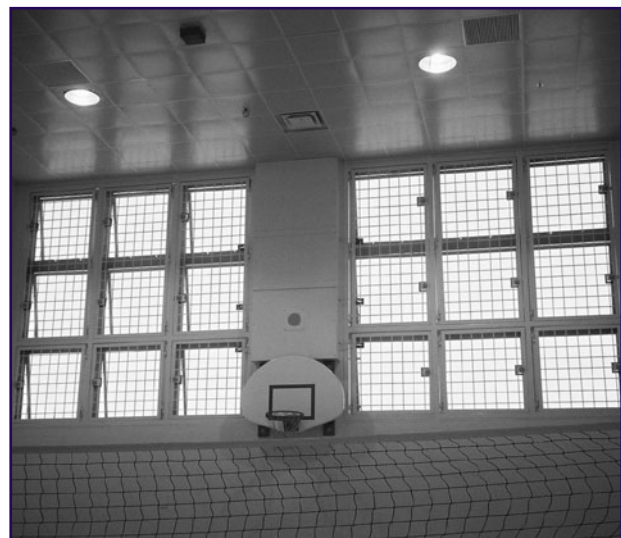

Windows opening into an indoor/outdoor exercise area. Note the mesh covering the open windows.

(Photograph courtesy of Voorhis Robertson Justice Services.)

- The walls of the indoor space must be developed as though they were exterior walls, that is, they must be impervious to rain and cold.
- The floor of the space must have drains.
- The space should be heated and cooled like other indoor areas; however, these systems might run independently to allow them to be turned off when the windows are opened for air flow.

In considering the dual-use exercise space concept, a jurisdiction should recognize that the chief deficiencies of this option are that exposure to open air and sunlight is limited and that the “outdoor” space is typically smaller than normally provided. Before committing to the concept, a jurisdiction should verify that the concept:

- Is consistent with the facility mission and goals.
- Provides adequate exposure to outdoor air and sunlight.
- Is consistent with applicable codes and jail standards.

Indoor Exercise

The following detailed functional-architectural issues apply to indoor exercise: multipurpose functioning and environmental considerations.

Multipurpose functioning

ISSUE: If an indoor exercise area is to be used for more than exercise functions, the functions should be carefully selected and appropriately accommodated through design.

RESPONSE: Jails sometimes attempt to use the indoor exercise area for other functions such as library, chapel, and counseling, among others. For such multiple users, some special accommodations may be

needed. For example, to use an indoor exercise area as a library, exercise must be limited to light and restricted activities, such as table tennis or weightlifting, and/or the library stacks must be in shuttered cases or in areas that can be partitioned off for protection during vigorous activity. However, the characteristics of an exercise area used for vigorous activities are generally not compatible with those desired for other program/service activities in terms of functions, materials, and environmental quality. More on the subject of multipurpose use can be found in chapter 20, “Programs and Services.”

Contact visiting areas are generally not compatible with exercise spaces because contraband could be hidden during visiting hours and retrieved later during exercise periods when thorough body searches are not routinely done. Aside from architectural compatibility, one key to determining the potential for creating a multipurpose exercise area is to do a realistic schedule of all activities and to determine the needs and numbers of persons using the activity. Future needs must also be considered.

Environmental considerations

ISSUE: Sound quality in, and noise transmission from, exercise areas should be controlled.

RESPONSE: The level of sound in an indoor exercise area can prevent people from communicating effectively. Communication via intercom systems can be obscured because of echoes created by hard surfaces. This sound problem can be mitigated by using acoustic treatments and/or sound-absorbing floor surfaces. Carpet or other applied resilient floorings can be used in place of bare concrete.

Section 3: Functional Components

Given that exercise is a potentially noisy activity, good sound insulation between areas is particularly helpful when the exercise area is adjacent to housing, visiting, counseling, and control functions.

Outdoor Exercise

The following detailed functional-architectural issues apply to outdoor exercise: activities, security, and fire safety.

Activities

ISSUE: Plan to use outdoor exercise areas in cold and inclement weather.

RESPONSE: Damp or cold weather will not necessarily eliminate inmates' desire to get some fresh air or sunlight. Therefore, a facility should be prepared to issue appropriate clothing—gloves, sweatshirts, jackets, foul weather footwear, and hats. Proper space for storage and distribution of these items should then be provided.

Security

ISSUE: Special attention should be given to controlling escape attempts.

RESPONSE: Experience and research both show that escape risks are high with outdoor exercise. Using solid, security-constructed walls and installing a sturdy, tightly woven screen or mesh over outdoor areas will help solve security problems while still allowing the introduction of fresh air and sunlight.

Blind spots should be eliminated wherever possible, and drain covers, fixtures, and other items that can be dislodged and used as tools to aid in an escape attempt should be securely fastened.

To help solve staff surveillance problems, locate outdoor areas where they can be seen from a



Mesh-covered outdoor exercise area.
(Photograph courtesy of Jim Rowenhorst.)

constantly staffed post. Locating outdoor exercise areas adjacent to housing units and providing views from the staff workstation into the exercise area can also provide an additional level of security. CCTV monitoring in lieu of staff surveillance or supervision fails to provide the necessary ability to detect and respond to escape attempts and fights between inmates. To allow control and surveillance of the area at all times, whether or not it is being used, consider providing artificial lighting for the area.

ISSUE: Special attention should be given to controlling contraband passage.

RESPONSE: The passage of weapons, drugs, messages, and other contraband to inmates by outsiders can be controlled through a combination of operational and architectural means. Operationally, staff should check the exercise area for contraband before, after, and during exercise periods. Architecturally, the same techniques noted as ways to control escape attempts should be considered. Another idea would be to surround the

exercise area by the building itself, thereby making it less noticeable and accessible to outsiders (exhibit 19-5).

A special security concern arises when work release and/or inmate workers use the same activity space as the general inmate population, regardless of whether that space is outdoors or indoors. There is a potential for contraband passage by prior arrangement that must be managed by searches of the space and the inmates.

Another physical detail to control is drainage. Openings in walls for exercise area drainage or snow removal can provide a natural route for contraband passage if they are adjacent to public areas and are not properly screened or protected.

ISSUE: Outside view and voice contact between the public and inmates should be controlled.

RESPONSE: Although the use of high, solid walls eliminates direct public view of and conversation with exercising inmates, total isolation of sound is nearly impossible. In

heavily populated areas, such as jails built in city centers, placing the outdoor area(s) toward the back of the facility can help control random public/inmate sound transmission. Constructing rooftop exercise areas to minimize contact problems is discouraged because additional movement problems, staff requirements, and snow removal and drainage problems can result.

Fire safety

ISSUE: Outdoor exercise areas should be evaluated for their potential as a controlled emergency refuge area.

RESPONSE: All jail administrators face the problem of controlling inmates during emergency evacuations. In many cases, emergency evacuation needs are limited and can be handled by moving inmates from one fire-protected zone of the building to another. However, evacuation from the building itself may be necessary. In this case, it may be useful to let an outdoor exercise area double as a place of outdoor refuge, thus solving evacuation needs without releasing inmates to the street.

Exhibit 19-5. Outdoor Exercise Area Surrounded by Building

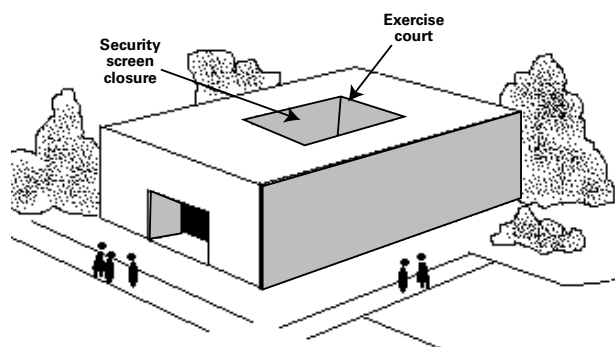

Specific requirements apply for an outdoor area if it is to be used as a temporary refuge. According to the National Fire Protection Association's *Life Safety Code*¹, all inmates should be able to attain a specified distance from the building at risk (see the code for current requirements) (exhibit 19-6). Once that distance is reached, there are specific requirements for the number of square feet required per inmate and other occupants (potentially staff) in the refuge area.

¹ National Fire Protection Association, *NFPA 101®: Life Safety Code*[®] (Quincy, MA: National Fire Protection Association, 2009).

Exhibit 19-6. Emergency Refuge Area

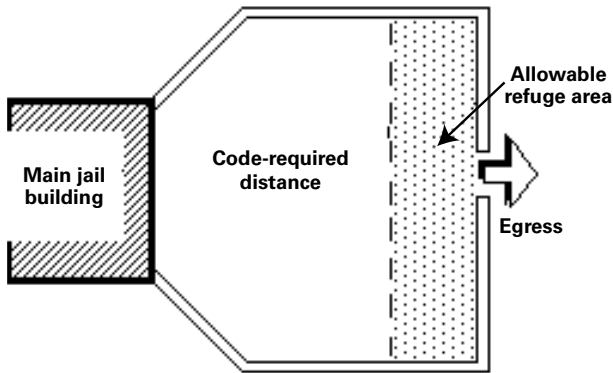

The refuge area should have a security exit door to the outside with a security lock, hardware, jamb, head, and threshold. A two-door vestibule system at the exercise wall is another possibility. Staff should control the keys to the refuge exit door(s) by keeping them locked in a secure cabinet, usually in master control, unless there is an emergency, with a separate set accessible to the fire department under controlled circumstances. Planners should refer to state and local fire codes to determine the requirements that must be met to use outdoor exercise areas as places of refuge in their specific jurisdiction.

Space List

Some of the spaces that might be found within the exercise component include the following:

- Indoor exercise area:
 - Equipment storage.
 - Restroom/search area.
 - Exercise/recreation office.
- Outdoor exercise area:
 - Equipment storage.
 - Restroom/search area.
 - Coat/hat storage.

See local codes and the Americans with Disabilities Act regarding accessibility requirements.

Relationships and Components

Exhibit 19-7. Relationships Between Exercise Areas and Housing and Public Areas

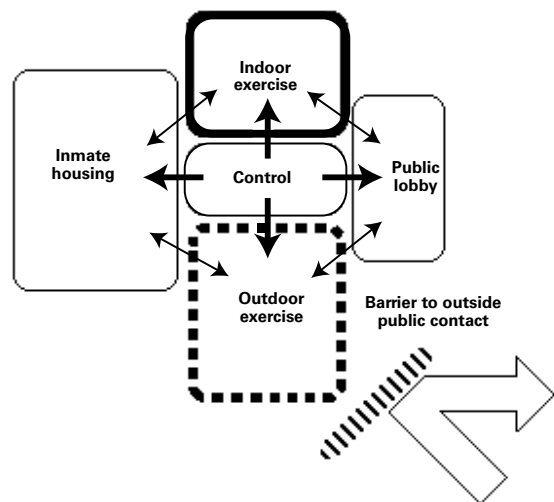
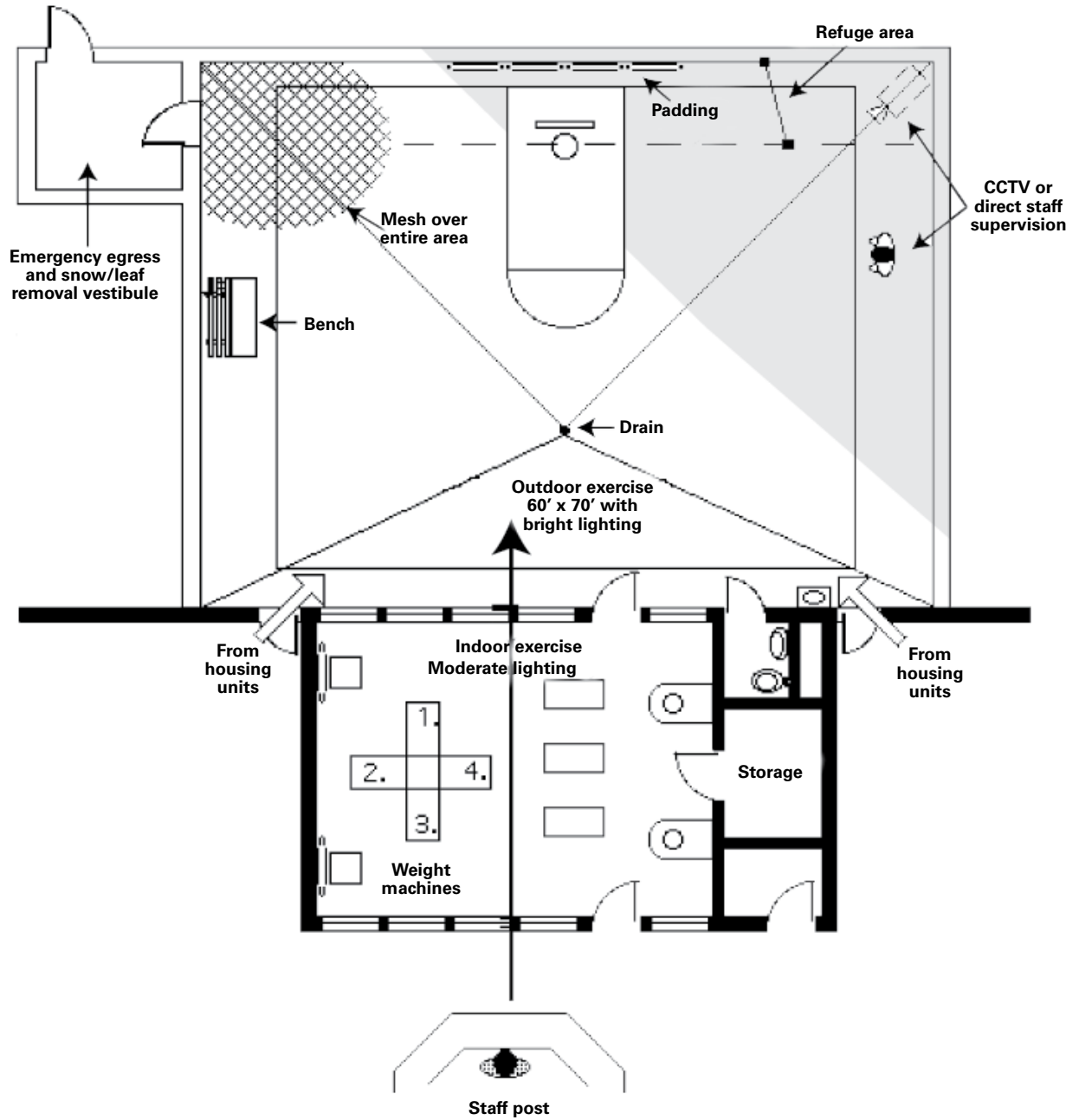

Exhibit 19-8. Components of Indoor and Outdoor Exercise Areas



A variety of programs and services can be provided to enhance staff management capabilities and fulfill the mission of the facility, whether that focuses on restraint, reintegration, reform, or rehabilitation. Some programs and services, such as religious services and legal library resources, are required by state standards and court decisions.

This chapter addresses the functional design issues regarding the following inmate programs and services: counseling, religious services, legal and recreational library resources, education, recreation, self-improvement programs (e.g., Alcoholics Anonymous, Narcotics Anonymous, anger management), and jail industries, if the jail decides to implement such a program.

In older linear jails and smaller jails, space for these important inmate activities was generally unavailable. Consequently, the jail administration's ability to respond to legal demands for programs and meet evolving concepts of inmate management was limited to a great extent by physical plant design. In response, some jurisdictions converted cellblock, office, or adjacent law enforcement areas (such as the sheriff's residence) to program space. Such attempts to create program space frequently created security and movement problems for the jail.

Today, it is important to consider program and service space during the earliest stages of planning. A common response for jails is to create multipurpose areas that are sufficiently large and/or flexible to meet the needs of a wide variety of programs and services that might be provided instead of creating separate spaces for each.

Key Decisions

The following decisions should be made as the role of the programs and services component is evaluated, because these decisions have a fundamental effect on design requirements:

- Which programs and services will be provided (consistent with the facility's mission and state standards)?
- How frequently will they be provided, and to whom?
- To what extent will outside resources be used, whether it is service providers coming to the jail or inmates going out to the services?
- Will the nature and frequency of selected programs and services permit use of a multipurpose space? What programs and services should not occur in the same space because of security, functional, or environmental conflicts?
- Will small-scale, passive recreational programming be provided? If so, will this recreation occur in the housing areas and will it be in lieu of vigorous indoor exercise or in addition to it?

Detail Issues

The detailed functional-architectural issues that are most crucial to the inmate programs and services component are discussed here. General issues that seem applicable to all of the programs and services are discussed first, including the multipurpose concept and the compatibility issues that surround it. Issues relevant to individual programs or services are then addressed.

General Issues

The following issues apply generally to the inmate programs and services component: location/users, separation/supervision, quality, security, and multipurpose possibilities.

Location/users

ISSUE: The location of program and service components should facilitate proper surveillance and supervision, effective functioning, and access for service providers.

RESPONSE: A consistent characteristic of inmate program and service spaces is that outside service providers will use the spaces in conjunction with the inmates. This suggests several general principles about the location of inmate program and service areas:

- They should be easily accessible through a secure vestibule entry through the security envelope of the jail to ensure control of all movement into the jail.
- Service providers, who are not jail staff, should have a background investigation and be cleared through a metal detector before entering any area accessed by inmates.
- If possible, the inmate program and service areas should be observable from a constantly staffed post without violating the privacy required by the function, service, or program taking place. Minimally, officers should conduct routine security rounds in program areas.
- Program and service areas should be sufficiently isolated from significant noise generated by movement within the jail or other activities (e.g., mechanical areas, indoor or outdoor exercise areas, kitchen, and laundry).



Multipurpose room in a smaller jail. Note the computer terminals and storage cupboards.

(Photograph courtesy of Jim Rowenhorst.)

Separation/supervision

ISSUE: Separation requirements and supervision methods for program functions will affect the need for space.

RESPONSE: Separation criteria for program and service functions may be quite different from those for the housing areas. The degree to which separation requirements are minimized depends a great deal on the method of supervision, the nature of the activity, and the duration of the activity.

Depending on pertinent standards, it may be that both medium- and low-security adult male inmates, and even selected adult female inmates, may jointly participate in a substance abuse counseling program or in religious services. This possibility increases if program staff are present at all times during the event and the space is under observation by a security officer. Such merging of inmate groups reduces scheduling demands on the space and the possibility that more than one space will be needed. Conversely, if

an activity such as recreation were to take place without constant and direct supervision by staff or even observation from a remote post, it would be best to maintain the same separations used in housing.

Quality

ISSUE: The quality of the program and service area environment should reinforce and complement the activities.

RESPONSE: The following considerations generally apply to inmate program and service areas:

- Visual privacy from activity and movement in adjacent spaces that might distract program participants or detract from the activity at hand.
- Acoustic privacy through the use of ceiling treatments, carpeting, insulated walls, and other techniques that improve sound quality and minimize sound transfer from other activities and functions.
- The introduction of natural light.
- Adequate artificial light for particular activities, including some ability to control and vary light levels and focus.
- Pleasant and comfortable surroundings in general.

Security

ISSUE: Inmate program and service areas should be provided with adequate security.

RESPONSE: Even though inmate programs and services are generally considered benefits that might elicit positive inmate behavior, the fundamental security of the areas should not be compromised in any way. In essence, these areas should be developed much like any other secured area in the jail.

The only exception would be program, job training, or reentry facilities in a minimum-security setting. Following are some considerations:

- Regardless of the interior treatment of the program spaces, the perimeter of the area—especially when it includes exterior walls—must be as secure as any other portion of the building.
- Windows to the exterior should have the same security design elements as any other exterior window in the facility, although the narrow slits of glazing preferred for cells may be unnecessary in directly supervised program areas. View conflicts should be minimized.
- Program and service area interiors ideally should be visible from a constantly staffed post. At a minimum, roving staff should be able to view interiors from adjacent corridors.
- Staff and service providers working with inmates should be able to communicate directly with staff at a fixed post. A two-way intercom would be appropriate for this purpose. (In some cases, service providers are given a panic alarm to activate in case of an emergency.)
- In cases where direct observation is not possible, closed-circuit television (CCTV) should be considered but never relied on as the sole means of surveillance.

Generally, CCTV monitoring of counseling and interview spaces is permissible. However, it should be as unobtrusive as possible and should not hinder communication between participants. Under no circumstances should staff be able to

Section 3: Functional Components

monitor, either by audio or visually, privileged communications between inmates and legal counsel or clergy. In some states, inmates' consultations with legal counsel are to be out of view of all staff.

Multipurpose possibilities

ISSUE: Multipurpose space sharing for inmate programs and services is desirable as long as schedules do not conflict and functions are compatible.

RESPONSE: The relative flexibility in scheduling that is common when planning for programs and services provides an opportunity to save space through the creation of a multipurpose program space. However, it cannot be automatically assumed that one or several multipurpose spaces will meet all demands. Several important considerations must be taken into account when assessing the extent to which a multipurpose space suits the program and service needs of a jail, notably, schedule, flexibility, and compatibility.

Schedule. The schedule of activities is critical in assessing multipurpose potential. The planner must identify each program or service that will take place now and potentially in the future, and the frequency and duration of each activity. This information should be charted to determine the extent of the demand for programs and services. Predicting demand can be difficult if very few programs are available to inmates in the current facility; talking with staff at other facilities can help planners project the demand for various programs. Additionally, the schedule should reflect when programs and services will occur. For example, most programs and services may be in the evening hours for the convenience of outside service providers, thereby precluding use of a single multipurpose space.

Flexibility. The flexibility of the multipurpose space is crucial. The space must be able to accommodate the different furniture and equipment needs of each of the programs or services to take place there. For example, tables needed for table tennis are not appropriate for religious services, so they must be moved out of the way. Moveable, foldable, and/or stackable furniture is essential for a multipurpose space. In addition, ample storage space for equipment and supplies adjacent to a multipurpose area is critical (exhibit 20-1).

Flexibility also includes being able to adapt the fundamental character of the space. For example, it is valuable to provide acoustically effective foldable or removable partitions in a large multipurpose room to allow the size and character of the space to change as the functions and their needs change. This flexibility could allow for more than one group to use the space at the same time.

Another important flexibility consideration is the amount of time it takes to move furniture and change the character of the space to accommodate another function. Such setup time might be a critical factor in the scheduling of activities and the determination of whether a multipurpose space can accommodate as many functions as originally thought. A good example of a potential setup problem occurs when the dining function is merged with a multipurpose space function. The time it takes to clean the area after meals, move tables and chairs out of the way, and reset that

Exhibit 20-1. Storage Space Adjacent to Multipurpose Area

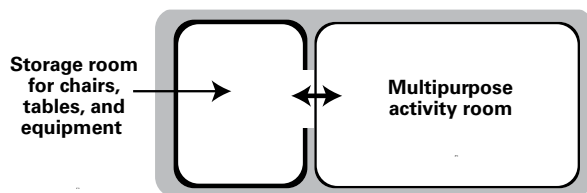

furniture three times a day creates considerable problems in terms of having adequate time to accommodate other functions in the multipurpose space. Flexibility also means providing accommodations for varied lighting needs, environmental needs, and equipment needs (audiovisual equipment, screens, etc.).

Compatibility. The fundamental compatibility of the various programs and services targeted for a multipurpose space must be closely assessed. It is possible that saving space by combining as many functions as possible in one or two areas would compromise the effectiveness or security of some functions.

Library carrels/reading area. Compatibility depends on the degree to which normally cumbersome study carrels can be moved out of the way during other activities and on the degree to which they contain equipment (such as computers, CD players, and audio equipment used in training), which should be protected from inmates during other activities.

Court hearings. If holding court hearings at the facility is a common occurrence, dedicated courtroom space should be provided to accommodate all parties to the proceedings. However, if court hearings within the facility are rare, steps can be taken to use a multipurpose space for this activity. Compatibility depends on the proper location of the space so that participants from the general public and court personnel can gain access without penetrating the inmate-occupied areas of the jail. Another consideration is the need for furniture and equipment to serve court purposes, such as a judge's bench, podiums, microphones and electronic gear, and a court reporter's desk.

The need for the public and legal personnel to move through a secure entry vestibule to court functions is another consideration. Such a secure entry would be required if the court hearing

room had a multipurpose capability that involved inmate programs and services.

If court hearings are limited to video arraignments or first appearances, there is no incompatibility with the multipurpose room as long as equipment can be stored and/or secured. Equipment would include a television (TV) monitor, camera, and microphone setup for the inmate, supervising officer, and, perhaps, an attorney.

Some functions seem clearly incompatible with other functions and therefore should not be conducted in the same multipurpose space: dining, indoor exercise, individual counseling, and contact visiting.

Dining. The dining function seems minimally compatible with any of the other programs and services listed, owing to the problems of dedicating the space for dining three times a day, the cleanup and setup time involved, and general concern about odors and sanitation.



Courtroom in a large jail. A separate viewing area for the public is located outside the secure perimeter of the jail.

(Photograph courtesy of Voorhis Robertson Justice Services.)

Section 3:
Functional Components

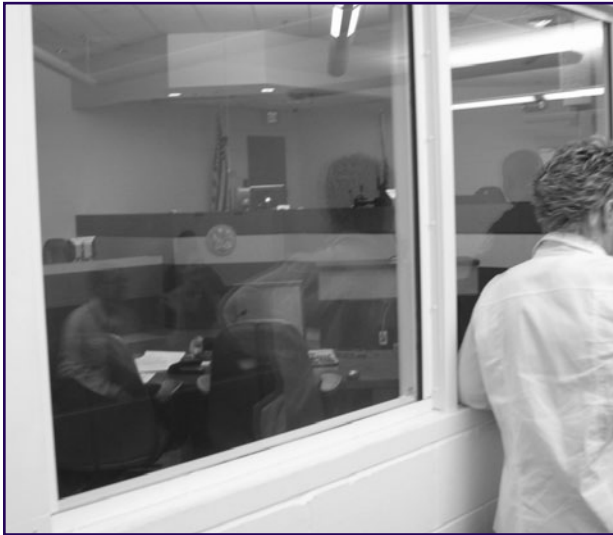

Separate court viewing area for the public for a courtroom located inside a jail.
(Photograph courtesy of Voorhis Robertson Justice Services.)

Indoor exercise. The scale, acoustics, equipment, and the vigorous activity associated with indoor exercise spaces, particularly those that accommodate such activities as basketball and volleyball, are fundamentally incompatible with the characteristics and needs of other inmate programs and services.

Individual counseling. Individual counseling spaces are intended for one-on-one counseling sessions. Spaces that are overly large, inadequately private, or subject to distraction should not be used as counseling rooms if at all possible. However, individual counseling rooms may be included adjacent to the multipurpose area (exhibit 20-2).

Contact visiting. Concern over the possibilities of contraband passage and the need to keep the general public out of the jail security envelope whenever possible suggests that contact visiting should not be merged with a multipurpose function if it can be avoided. Rather, contact visiting should occur in a controlled area just outside the

Exhibit 20-2. Counseling Rooms Adjacent to Multipurpose Area

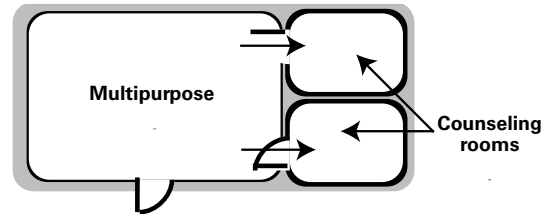
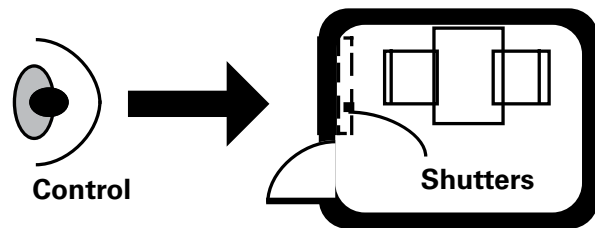

Exhibit 20-3. Use of Shutters To Provide Privacy in a Contact Visiting/Individual Counseling Area Not Associated With Multipurpose Space



primary inmate-occupied areas of the jail (exhibit 20-3). More information on the location and design of visiting areas is available in chapter 18.

Counseling

Counseling can be a valuable service to the inmate, the facility, and the community. Counseling services can help inmates deal with the tension and anxiety of their situation, aid them in adjusting to jail life, and assist them in controlling chronic personal problems. Counseling activities can include crisis intervention and help in dealing with substance abuse; family, religious, and educational issues; and employment. Counseling is also used to help orient new inmates to the rules and practices of the facility.

Counseling space types

ISSUE: The nature of counseling activities should be identified to determine the type of space required.

RESPONSE: Two fundamentally different types of counseling potentially involve different demands for space. One is individual counseling, which is a one-on-one experience between the inmate and the counselor. The other is group counseling, which usually involves a counselor and two or more inmates. Group sessions are most common in substance abuse counseling. Ideally, individual counseling will occur in spaces separate from group counseling. Group counseling, by its nature, is much more compatible with a multipurpose space than is individual counseling. Individual counseling is more compatible with smaller scale spaces suitable for attorney-client visiting or contact visiting.

Counseling space size

ISSUE: The size of counseling spaces depends on the number of participants.

RESPONSE: Spaces for individual, one-on-one counseling should be a minimum of approximately 60 square feet to allow for some comfort and avoid too great a sense of confinement. If the space cannot be provided with natural light and the sense of extended space that a window tends to provide, increasing the size of the space might be desirable.

The following rules of thumb might be useful for planning the size of group counseling spaces:

- Three to four persons: 100 square feet.
- Five or more persons: 100 square feet plus another 15 square feet for the fifth and each additional person.

Group counseling spaces should be properly proportioned. A nearly square space provides considerable flexibility in allowing the counselor to

create group settings that focus activities appropriately.

If a large multipurpose space that is longer and narrower than desirable must be used, the use of folding, moveable partitions may help attain the proper size and proportions for group counseling sessions.

Number of counseling spaces

ISSUE: The number of individual and group counseling spaces required depends on the frequency of use, the duration of use, and the scheduling of staff.

RESPONSE: Scheduling may be the key to determining the number of counseling spaces needed; for example, if two or more counselors must come at the same time of day, more than one space needs to be available. The need to provide dedicated individual counseling spaces may be served by the use of attorney-client or contact visiting spaces. This also depends on frequency of use, scheduling, and other compatibility factors discussed earlier.

If separate counseling space cannot be provided, another possibility for individual counseling is to use the office space provided for program staff within the security perimeter that can be monitored by security staff. For example, a work space provided for counselors could double as a counseling area if properly designed and if privacy can be guaranteed. Proper design involves having sufficient space to accommodate the counselor and the inmate in a proper setting separate from the work area. It also involves the ability to secure items that could be considered contraband if possessed by an inmate (for example, desk items). Counseling should not be planned for a shared office to which two or more staff need access at the same time.

Characteristics of counseling spaces

ISSUE: The characteristics of counseling spaces should complement the needs and the security of the activity.

RESPONSE: Several characteristics of counseling spaces should be considered:

- All counseling spaces should be comfortable, quiet, private, and minimally affected by outside distractions.
- Counseling spaces should have comfortable seating. It is helpful if the furniture is moveable so it can be arranged in a fashion most conducive to successful counseling.
- Natural light is beneficial but should be controlled to prevent unnecessary distractions from outside activities. It should also be provided through a securely designed window, skylight, or clerestory. Natural light improves the quality of the area and, with a window, provides some spatial relief, which tends to relax the inmate.
- Counseling spaces should be observable from a constantly staffed post if possible, but not overexposed. Privacy for counseling is critical to eliciting proper inmate participation. Small vision panels or partially screened or shuttered openings are more appropriate than expansive vision panels fully exposing the counseling activity to officers or inmates outside the space. A two-way intercom within the space can be a valuable aid to ensuring the counselor's safety.
- Often in direct supervision or remote supervision housing units, counseling spaces are built off the main dayroom area, within the housing unit. Bringing

services to the unit decreases the need to move inmates to counseling and allows for proper supervision.

Religious Services

ISSUE: Religious services must be accommodated.

RESPONSE: Accommodation of religious expression by the inmate population is a required part of the programs and services offered at a jail. Providing access to religious activities may include:

- Counseling on a one-to-one basis.
- Small group instruction (e.g., Bible study) anytime during the week.
- Weekly formal services, potentially interdenominational or multiple formal denominational services, depending on the composition of the inmate population.

In addition to these activities, there is usually a need to accommodate the storage of books, brochures, and paper supplies as well as the sacraments used as part of some religious services.

Religious counseling sessions can take place in individual counseling spaces or attorney-client visiting spaces, as long as scheduling conflicts can be avoided. Small group instruction and weekly services are quite appropriate to a multipurpose space. If religious services are to be held in a multipurpose space, consideration might be given to methods of attaining a more religious environment during services. One idea, for example, would be to create an altar area that could be closed off during nonreligious activity and also serve as a sacristy (a room in which sacred vessels, vestments, and hangings are stored) (exhibit 20-4).

Consideration should be given to the design impact of special religious activities, such as

Exhibit 20-4. Altar Area That Can Be Closed Off During Nonreligious Activities

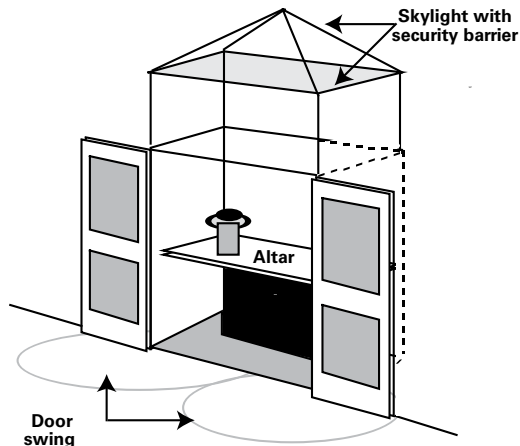

confessions or baptisms, if they are to be accommodated. Typically, confession requires private booths that allow a priest and the inmate to communicate quietly, while seated, through a heavily veiled opening. Such a need might be accommodated by designing a confessional space within the facility or by creating a portable booth that can be stored in an adjacent multipurpose storage area when not in use. Raised platforms for an altar area may be similarly portable.

As a rule of thumb, 15 square feet per user should be provided for religious services, exclusive of the area from which the cleric speaks.

Library Services

Libraries supply inmates with needed access to legal materials as well as recreational reading that can help them prepare for vocations, enlarge their social and educational backgrounds, and support facility management.

Library activities

Issue: The extent of library activities must be determined to provide proper space.

Response: Both fundamental library activities and optional activities greatly influence the size of the jail library. The basic purpose of a library in any jail is to store books, periodicals, and newspapers supplied by the facility for inmate use. Other activities associated with a basic library function include keeping records of books checked out and distributing, sorting, maintaining, and shelving library items as they are returned.

Several optional library activities that might be part of the jail program also affect space and equipment needs. They include:

- Maintaining a law library collection or computer access to one (outside sources may also be a viable method of providing inmates with access to legal materials).
- Reading and studying.
- Writing and preparing documents.
- Displaying notices and information about library materials and activities.
- Maintaining and using audiovisual equipment, including CDs and DVDs.
- Providing reading and study carrels, with support audiovisual equipment.

Most of these optional activities operate on the basic assumption that some or all of the inmates will go to the library to browse through materials, use them in the library, and/or check them out. However, many jails maintain only sufficient space to store books and the carts with which books are delivered to inmates. In this delivery scenario, inmates identify the books they want from a list of available materials and staff later fill their requests, or carts are assigned to the housing units and stocked with new books on a scheduled basis. Storage of library materials in a multipurpose space tends to provide the jail

Section 3: Functional Components



Inmate library in a small jail.
(Photograph courtesy of Jim Rowenhorst.)

administration greater flexibility in terms of operating the jail library in either manner.

Library size

ISSUE: Space needs must be determined by library activities and storage requirements.

RESPONSE: The size of a library space depends primarily on the activities that occur and the types and number of books and materials stored. Regarding the number of books, it is recommended that smaller jails provide roughly 20 books per bed and at least 1 magazine and 1 local, state, or national newspaper per every 10 residents. In larger jails, the number and types of books and periodicals provided to inmates could be significantly larger.

The following formula applies for calculating space for book storage (stack) areas:

$$\frac{\text{Total volumes}}{16} = \text{Required square footage for stacks}$$

Using this formula, a 2,000-volume library (100 beds × 20 volumes per bed) would require approximately 125 square feet of stack area exclusive of general circulation in the larger library space.

If provided, a reading area should be calculated as follows:

$$15\% \text{ of bed capacity} \times 16 \text{ square feet} = \text{reading area square footage}$$

By this formula, a 100-bed facility would need to provide 240 square feet of reading area exclusive of general circulation in the library.¹

Additional area should be considered when fixed study carrels and areas for audiovisual equipment are included. Another consideration is space for one or more computer workstations. For example, complete law libraries are available on CD-ROM as well as via the Internet. These computer workstations can also be used for education courses and training purposes. Additionally, in facilities where a more elaborate library is required, consideration should be given to providing space for a librarian's office, a paralegal's office, a workroom, a checkout area, and a staff computer terminal.

Library environment

ISSUE: The quality of the library environment is important in creating the proper library setting and preserving library materials.

RESPONSE: A library space has some environmental requirements that differ from those of other functions, especially those that

¹ These formulas were originally created by the American Correctional Association's Committee on Institutional Libraries and are published in *Library Standards for Adult Correctional Institutions 1992* (Chicago: Association of Specialized and Cooperative Library Agencies, 1992).

might be housed in a multipurpose space. These requirements are most applicable if the library is made accessible to inmates for book selection, reading, and studying.

- Artificial light levels should preferably reach 50 to 70 footcandles at 30 inches above the floor surface.
- Humidity levels should be controlled, preferably within a range of 56–70 percent.
- Temperature should be controlled, preferably within a range of 68–70 degrees Fahrenheit.
- Acoustic privacy and low reverberation levels are important to maintaining the integrity and function of a library area.
- Some visual privacy is necessary to reduce distractions, but the space should be observable from a constantly staffed post.



Computer workstations in a small jail library.
(Photograph courtesy of Jim Rowenhorst.)

- The space should generally be pleasant and comfortable.

Multipurpose use of library

ISSUE: The library function must be compatible with other functions that may share a multipurpose space.

RESPONSE: The library area poses some difficulty for a multipurpose operation because of the inflexible nature of stacking and storing books. This is further complicated if fixed valuable equipment, such as study carrels and computer workstations, is also in the space and cannot be moved and/or must be protected.

One way to prevent stacks from being damaged during other activities is to put lockable shutters over them. Another is to locate them at the back of the room where a moveable partition can be drawn in front of them during other activities. Stackable chairs and folding tables in reading areas also enhance multipurpose capabilities.

Education

Educational programs frequently occur in even the smallest jails. The following detailed functional-architectural issues apply to educational spaces: size and characteristics.

Size

ISSUE: The size of educational facilities depends on the types of programs offered and the number of participants.

RESPONSE: Even though jails can benefit from offering educational programs to inmates, it can be the case that inmates in jails do not stay long enough to participate in extended programs. Consequently, true need should be ascertained to determine whether a space as great as a dedicated classroom should be provided for educational programs. In larger facilities, several

Section 3: Functional Components

classrooms may be necessary to accommodate the educational opportunities available to the inmates.

Many educational programs consist of tutoring or work toward a general equivalency diploma (GED) with a teacher or volunteer working with a small number of students. For these applications, an individual counseling space or an attorney-client visiting space may be an adequate alternative to providing a dedicated space if no schedule conflicts occur. However, spaces used for tutoring or educational programs involving several inmates at one time should have marker boards, chalkboards, and/or other implements that aid in the teaching process.

Special space needs may arise depending on the nature of the educational program offered. For example, some jail educational programs involve independent study via audiovisual equipment or computers for e-learning placed in fixed study carrels or table areas. This approach to education requires space for the carrel or table and the equipment as well as supervision and supplemental instruction by educational staff. Such a program should not only have dedicated space for the equipment, but should be located where monitoring capability is available.

One form of educational program that is unusual for smaller jails but common in larger jails is vocational training. Programs involving cooking, auto repair, carpentry, or other specialized activities could have a dramatic impact on space and equipment needs. Many times special buildings are constructed specifically for these vocational training programs to accommodate special equipment and training space.

Educational space characteristics

ISSUE: Educational spaces should be designed to complement the various activities that might take place.

RESPONSE: For educational space to function effectively, some general characteristics should be attained. These apply especially to educational spaces for teaching inmates in groups rather than individually:

- Equipment/furnishings:
 - Moveable furnishings.
 - Durable furnishings.
 - Computer workstations.
 - TV monitors for instructional digital video disks (DVDs)/tapes or broadcasts.
 - A range of furnishings and equipment appropriate to the functions, such as student desks with writing surfaces versus chairs and tables, desk or podium for teachers, blackboards/whiteboards, screens, and clocks.
- Environment:
 - Proper acoustic separation from noise-generating areas.
 - Good ventilation and controlled temperature.
 - 50–70 footcandles of artificial light 30 inches above the floor surface.
 - Artificial light that provides options for intensity to accommodate a wide range of activities (verbal instruction, slide shows with note-taking, films, etc.).
 - Natural light, if possible.

Recreation

Recreation differs from indoor exercise in that recreational activities (e.g., table tennis, crafts, painting) are less physical and require considerably less square footage than indoor exercise.

ISSUE: Recreational activity needs must be identified to specify space requirements.

RESPONSE: Recreational needs may greatly influence the size and shape of the multi-purpose space if recreation is to take place in such an area. The dimensional requirements for an area to accommodate one or two table tennis games, for example, can greatly influence the amount of space needed (exhibit 20-5). Often in larger jails or direct supervision facilities, additional dayroom space is allocated to accommodate indoor recreation instead of creating a separate recreation space.

Recreational programs involving movies with screens and projectors, or DVDs and TVs, can generate equipment needs that affect not only the size of the space but also its orientation and the need for supplemental storage.

Jail Industries

Although jail industries are primarily viewed as a large jail or prison activity, some small and, particularly, medium-sized jails might decide to implement a jail industry program. Examples of these programs include furniture making or repair, product packaging, and recycle sorting. The issue of jail industries should be fully explored and evaluated during the planning process to assess the activities involved and the amount and type of spaces required.

Space List

Some of the typical spaces that might be found within the programs and services component as individual spaces or merged into multipurpose applications are:

- Counseling:
 - Individual.
 - Group.

Exhibit 20-5. Area Requirements for Different Activities

Table tennis		
One table	23 x 13 x 9	2-4
Two tables	23 x 24 x 9	4-8

- Religious:
 - Personal counseling.
 - Services/instruction.
 - Storage.
- Library:
 - Recreational and legal:
 - Stack area.
 - Reader area.
 - Work area.
 - Computer workstation area.
 - Study carrel area.
 - Storage.
- Education:
 - Classroom.
 - Storage.
- Recreation:
 - Recreation room.
 - Storage.

Section 3: Functional Components

- Staff facilities:
 - Offices.
 - Toilet(s).
 - Storage.
 - Closet.
 - Reception/secretary.

Local codes and Americans with Disabilities Act guidelines regarding accessibility requirements should be consulted when planning these spaces. Depending on the overall building concepts, these spaces may be organized together as a discrete program/services component, be spread throughout the facility, or integrated, in part, into the housing units.

Relationships and Components

Exhibit 20-6. Relationship of Programs/ Services Area to Housing and Lobby

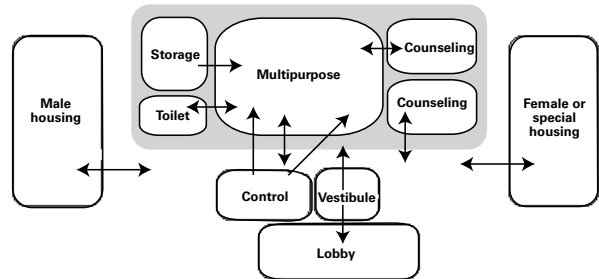
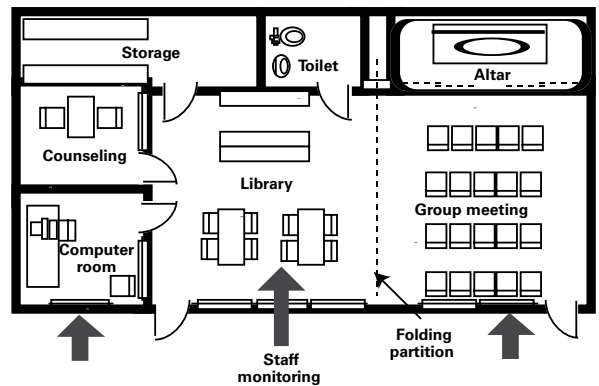

Exhibit 20-7. Components of a Programs/ Services Area



Chapter 21

Inmate Commissary

An inmate commissary allows inmates to purchase snacks, supplies, and personal items not normally supplied by the jail. Items necessary to basic hygiene (e.g., soap, toilet paper, toothbrush) should be provided by the facility at no cost.

The inmate commissary is generally viewed as a privilege, not necessarily a right, as long as basic hygiene items are provided and food service is adequate and it is not necessary for the inmates to supplement facility meals from a commissary. The trend nationwide is to either provide commissary services at the jail or use outside contract sources to manage the commissary operations. This is done in lieu of allowing friends or family to bring items to the jail because of the potential for the introduction of contraband.

Providing inmates with an opportunity to purchase personal items gives them some control over their lives. It also provides the jail administration with an effective management tool for controlling inmate behavior because the commissary privilege can be withdrawn for violations of institutional rules. Additionally, profits from commissary operations can be used to provide for or supplement inmate programs or other services, supplies, or equipment.

Commissary operations have often been troubled by problems related to loss control and fiscal accountability. However, the commissary need not be a problem as long as secure storage and proper distribution and accounting procedures are followed.

To some degree, the decision as to who will manage the commissary will determine where the commissary should be located. Administration of the commissary operation can be handled in

many ways and is often assigned to food services staff, inmate program staff, correctional officer(s), assigned commissary/warehouse staff, or contract commissary providers, depending on the jail's personnel situation and management philosophy.

Sound correctional practice and many state standards require that inmates with funds on account be provided with an opportunity to purchase discretionary items not provided by the jail. It is important to check state standards or statutes with regard to commissaries, as a few states prohibit the establishment of petty cash funds or other such accounts outside the usual county financial chain of control. Some states require that inmate funds and profits from commissary operations be held in trust accounts and used only for the benefit of the inmates.

Key Decisions

The following decisions have a fundamental effect on design requirements for a commissary and should be made when the role of this component is evaluated:

- What is the anticipated size and scope of operation?
- Will the commissary role be more broadly defined to include storage of all basic supplies for the facility as part of a warehouse area?
- Given the size and scope of the commissary operation, will the jail rely on an in-house stock of commissary goods or on a retail outlet outside the jail (i.e., local stores or shops)?
- If the commissary is provided by a contract service, will the service need space to store goods and fill orders or will they be delivered prepackaged to the facility?

Section 3: Functional Components

- Will commissary goods be brought to the inmates in their housing units or will the inmates, as an additional privilege, go to the commissary to pick up their goods? If the latter, will all inmates, including those in maximum security, be allowed to visit the commissary?
- Who will administer the commissary function, and who will package the orders? Where will the accounting and administrative services be located?

Detail Issues

The following detailed functional-architectural issues should be considered in the development of the commissary component: size, location, equipment, security, and communication.

Size

ISSUE: The size of the commissary will depend on the inventory requirements, activities, and equipment involved in service delivery.

RESPONSE: Although commissary and warehouse activities take a considerable amount of space in large jail systems, due to the volume of goods moved through the system each day, the commissary of a small or medium-sized jail will typically involve a relatively small amount of square footage. However, the amount can vary significantly depending on the inventory involved. Inventory is affected by the:

- Number of inmates served.
- Range of items offered.
- Amount of each item stocked.
- Type of storage required (dry storage versus cold and/or frozen).

A minimal commissary may limit its stock to candy, snacks, and basic personal hygiene items, such as shampoo and toothpaste. Additional items that might be considered include:

- Beverages (tea, coffee, soda).
- Toiletries in addition to facility issue (deodorant, soap, hair conditioner, skin lotion).
- Cleansing tissues, handkerchiefs.
- Radios, batteries.
- Greeting cards, stationery, envelopes, stamps.
- Inmate clothing (underwear, socks, shower shoes).

Other factors affecting the size and design of the commissary relate to activities and equipment, including:

- The efficiency with which items are stored.
- A refrigerator and/or freezer for soda, ice cream, and other items that require cold storage.
- Work surface and seating for staff administering the commissary. The work surface should be large enough to do paperwork on receipts, request slips, inventories, and order forms. If the facility uses a computer-based accounting system, additional surface area for keyboards and monitors will be required. A regular staff workstation or post could be used if the commissary is managed by regular jail staff.
- If cash is used in transactions, a place for a secured cash drawer or safe. Alternatively, a separate commissary checking account might be maintained at a local bank.
- A lockable file cabinet for storage of inmate commissary accounts, financial records, ordering information, and other papers.

- If commissary items are brought to the inmates, space in which to store a mobile cart, unless a cart from the kitchen or the health care area can be borrowed.
- If commissary items are distributed at the commissary area (i.e., inmates go to the commissary), a securable passthrough window. This can be a Dutch door or opening in the wall with a counter. The counter area should be securable with a lockable overhead rolling shutter or a lockable swinging window or door.
- If inmates go to the commissary, an area for a display cabinet or shelves they can see but not touch.

Location

ISSUE: The location of the commissary depends on the extent of service, the delivery mode, and accessibility.

RESPONSE: If inmates go to the commissary, which is most common in minimum security or work release facilities, it should be located in an area where a waiting line does not congest a circulation corridor. It is also preferable that the area be visible from a constantly staffed post, thus eliminating the need for additional escort staff while the staff member providing service is inside the commissary room. A view of the commissary from a staff post is not necessary if the service is brought to the inmates in their housing units.

If inmates go to the commissary, it may be useful to consider affiliating the commissary space with a multipurpose area (exhibit 21-1). In this way, staff can consolidate two activities in one movement sequence and share the view control that would normally be integrated into the design of a multipurpose area. No matter the delivery method, the commissary area should be located in a secure area near the loading dock or facility warehouse to allow for ease in accepting deliveries.

Exhibit 21-1. Commissary Adjacent to Multipurpose Area

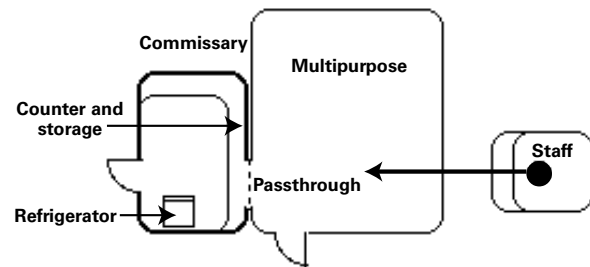

Inmate dining hall with vending machines.
(Photograph courtesy of Voorhis Robertson Justice Services.)

Equipment

ISSUE: Determine whether vending machines will be used to provide commissary items.

RESPONSE: Many jails have found that, with proper supervision, it is possible to permit inmates to carry small amounts of change, although it is preferable to offer the ability for them to purchase debit cards with unique pin numbers. Therefore, it is possible to run a vending operation as part of

Section 3: Functional Components

the commissary or to locate machines in a housing area or multipurpose room as long as they do not interfere with other functions. It is important to evaluate the vending machine issue before design to avoid the placement of machines in inappropriate locations (e.g., in corridors or staff areas to which inmates must then gain access).

Security

ISSUE: Access to the commissary must be strictly controlled, whether the commissary consists of a locked storage closet, a separate room, or a large warehouse.

RESPONSE: Security and inventory control should be attained by limiting access to the commissary area to essential staff and maintaining strict key control. The keys to the area should only be given to commissary staff or should be checked out from master control or the jail administration if there are not staff dedicated to working in the commissary. Locating the commissary in an observable location or an area with limited access also assists in general security.

Communication

ISSUE: Communication with master control is essential.

RESPONSE: As with most areas within the jail, there should be a telephone or intercom link with master control. This is particularly true with a centralized commissary dispensing location, as the commissary staff will have to notify housing units when deliveries are coming.

Space List

Some of the typical spaces that might be found in the commissary component follow.

- Storage area.
- Work area.
- Inmate waiting area (for centralized commissary only).
- Receipt and staging area (for contract deliveries).

Local codes and Americans with Disabilities Act guidelines regarding accessibility requirements should be consulted when planning these spaces.

Relationships and Components

Exhibit 21-2. Relationship of Commissary to Housing and Multipurpose Areas

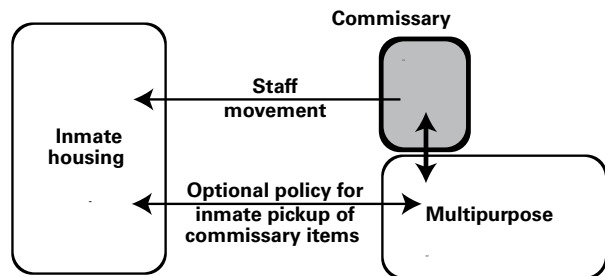
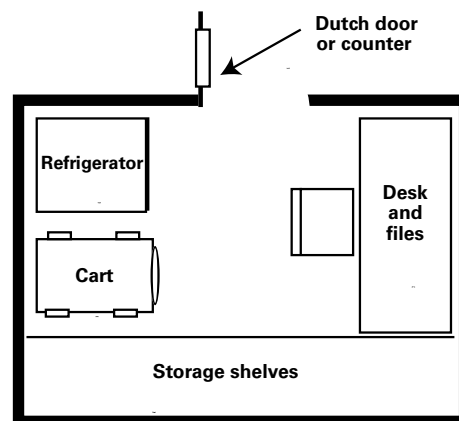

Exhibit 21-3. Commissary Components



Chapter 22

Food Service

Food service has a major impact on daily jail operational routines, annual operating costs, and initial construction costs. It presents many security concerns, is a regular disruption to other jail operations and supervision needs, and is a major factor affecting inmate attitudes and behavior. The quantity and quality of food and the means of preparing and serving it have often been at issue in inmate grievances and lawsuits. In these instances, inadequate documentation of meal planning or difficulties maintaining equipment to current standards for institutional food service can become very troublesome for jail administrators.

Constructing sufficient work space and providing adequate storage areas and equipment to respond to inmate dietary needs can be quite expensive and make a substantial dent in the normally limited jail construction budget. Thus, careful consideration must be given to how food service will be implemented.

Food service encompasses a variety of basic activities:

- Menu planning and food ordering.
- Receiving and storing foods and related supplies.
- Food/beverage preparation.
- Food/beverage delivery.
- Inmate dining (in those facilities that wish to have a centralized dining area).
- Staff dining (all facilities should provide an area outside the housing areas or control rooms in which staff members can take breaks and eat their meals).
- Cleanup and dishwashing after meals.



Full service kitchen in a small jail.
(Photograph courtesy of Jim Rowenhorst.)

- Disposal of waste.
- Record keeping.

The design of jail food service areas should focus on providing quality facilities that minimize food preparation time, enhance the ease of delivery without compromising food quality, and accommodate future capacity needs without requiring later expansion of food service areas. The character of the food service area and the materials and finishes used are similar to those used in conventional institutional kitchens, with the exception that perimeter and internal security must be provided.

American Correctional Association standards focus primarily on policies, procedures, and documentation of an inmate food service operation. Besides requiring three meals per day, these standards are aimed primarily toward ensuring the dietary and hygienic adequacy of a jail food

Section 3: Functional Components

service operation. They do not attempt to dictate specifically how that service is to be provided.

State and local food service and public health requirements should be checked carefully. Most state and local jurisdictions have health department and sanitation codes regarding the preparation and handling of food and the disposal of food waste products. These state and local requirements define a minimum operational level that must be met at all local food service facilities. Most state jail standards also address requirements for jail food service.

Key Decisions

The following decisions have a fundamental effect on design requirements and therefore should be made when the role of the food service component is evaluated:

- Will food be prepared at the facility or be provided by outside sources such as a central kitchen serving several facilities, local schools, or hospitals? Or, will “easy” cold meals such as breakfast cereal or lunch sandwiches be prepared at the jail and hot meals come from an outside source?
- If meals are provided by an outside source, what facilities and equipment will be required at the jail to serve the meals? Will the meals have to be reheated in a retherm kitchen? Will meals items arrive in bulk or already on trays?
- Will inmate dining occur at a central dining area or within the housing units? If at a central dining area, will all inmates, regardless of classification, use the facilities? If at the housing units, what method of food delivery will be used to ensure that proper food temperatures and quality are maintained?
- How frequently will food supplies be ordered, and what effect does this have on storage needs?

- Will minimum-security inmate workers be available to assist in food service operations and, if so, to what extent?
- How will food service facilities be designed to accommodate future expanded inmate capacities?

Detail Issues

The following detailed functional-architectural issues should be considered in the development of the food services component: the food service provider, the location of inmate dining, food preparation and storage, cleanup and waste handling, food delivery, staff accommodations, security, inmate workers, and the staff dining area.

Food Service Provider

ISSUE: A choice must be made between providing food services in-house (either using jail staff or a food service vendor) or contracting for food service from outside sources.

RESPONSE: Some smaller jails use an outside food service source that will prepare meals at its own facilities and transport them to the jail. Bringing in food from the outside is generally not done in larger facilities due to the volume of meals served and issues with transportation and maintaining food temperatures. Bringing in food from the outside can be done through a private food service company or restaurant or a nearby institution, such as a hospital, nursing home, or school. Although this method poses several potential problems, comparing long-term costs and evaluating operational concerns could prove worthwhile.

The primary advantages of using outside sources include:

- Eliminating the floor area required for kitchen and food storage from construction costs.
- Eliminating food service equipment from initial project costs.
- Reducing the overall mechanical and electrical load requirements of the building.
- Simplifying operational purchasing and maintenance needs.
- Eliminating costs for cooking staff.
- Eliminating periodic costs for repair or replacement of obsolete kitchen equipment.
- Eliminating kitchen cutlery from the secure jail area.

Some potential disadvantages of using outside sources include:

- Attempts to conceal contraband in food trays and carts brought to the jail.
- Increased security staff time involving movement of food into and out of the jail security perimeter.
- Possible inability to add efficient kitchen space to the building if the contracting service must be abandoned.
- Lack of control over escalating contract costs.
- Potential operational difficulties if the contract service temporarily shuts down (e.g., schools during summer vacation, facilities during renovations).
- Possible need for equipment for backup cooking, warmup, or delivery.
- Possible need for dishwashing/cleaning equipment.

In an ideal situation, the outside food service source would provide the following items to reduce staff work and facility space needs:

- Meals that are preplated in disposable or reusable insulated trays with meal temperature adequately maintained in transit.
- Cups and utensils that are either disposable or returned to the provider for cleaning.
- Beverages in insulated containers that can be used for dispensing and returned to the provider for cleaning.
- Delivery carts.

If any or all of these elements are missing, they must be provided and accommodated at the jail, implying the need for a fairly significant amount of space and equipment, although still not as much as a full kitchen with full storage capabilities.

It is also important to create a secure method of receiving the food from an outside provider. This point of entry should be configured and operate as a security vestibule because it represents a penetration of the security perimeter of the jail.

In-House Food Service

If food services are to be provided in-house, the primary operational concerns would focus on the potential use of inmate workers and, therefore, whether food service staff would have supervision and security responsibilities in addition to meal preparation and cleanup.

Kitchen activities require cutlery and other equipment that could become weapons. Where inmate workers will assist in food preparation and cleanup, special precautions for food delivery, trash removal, inventory control, and the location of inmate worker housing must be considered. Also, when inmate workers are used, there is the question of whether food service staff must be trained to provide inmate supervision or whether intermittent or electronic monitoring by other jail staff will be adequate.

Section 3:
Functional Components

Other tasks associated with food service include menu planning, food purchasing, and maintaining food service records. The design considerations for these tasks are discussed in the functional issues to follow.

Location of Inmate Dining

ISSUE: The location of inmate dining and the method of food delivery must be established.

RESPONSE: Dining can be centralized or decentralized.

Centralized dining

A centralized dining area has the potential advantage of using a serving line and dining space adjacent to the kitchen. This location eliminates the need for tray assembly time and food carts, provides the quickest delivery of hot foods, and simplifies cleanup (exhibit 22-1).

Unfortunately, this method of dining creates a number of major operational problems, especially in facilities that house all classifications of inmates. Maintaining the separation of different housing classifications during mealtime can prolong food service times with many groups of inmates in the dining area at different times. If central dining takes place in a general multipurpose room rather than a designated dining area,

Exhibit 22-1. Centralized Dining Area Adjacent to the Kitchen

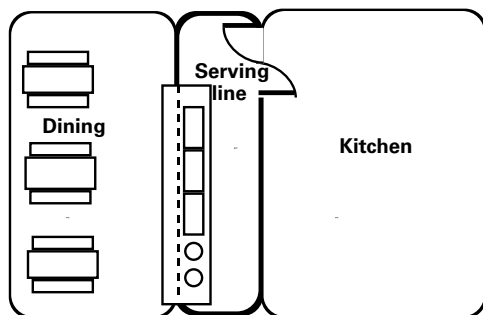

the time needed for food service and cleanup would likely eliminate most other activity uses in that area. Moving groups of inmates to and from dining three times a day substantially increases staff monitoring responsibilities and could require more supervisory personnel. Inmate movement to and from dining could severely restrict other jail activities for prolonged periods of time while the different inmate classification groups are allowed to eat, the area is cleaned, and the next group brought in. Consequently, central dining in a multipurpose room is generally discouraged, especially when sanitation issues are also considered.

Decentralized dining

Decentralized dining, which involves moving prepared food trays in carts to the various housing pods, is the most common method of inmate dining. Inmates eat at dayroom tables and are monitored by the housing area security staff. This tends to facilitate dining with minimal movement and security problems.



Centralized dining hall in a minimum-security facility.
(Photograph courtesy of Voorhis Robertson Justice Services.)

Two classic problems with dining within housing units have been (1) insufficient space for rapidly and effectively distributing meals, including drinks, and (2) maintaining proper food temperature. The most common response to these issues is the use of thermal trays designed to maintain food at a proper temperature for extended periods of time. Thermal trays can be brought into the housing unit on carts and distributed. Planners should include a tray and beverage service station in each housing area to facilitate this process.

Another response to these problems is to complete the tray assembly process in the housing units. As an example, bulk food containers are set up in each housing unit or general housing area for final tray assembly, in some cases employing a cafeteria-style serving line. In some instances, microwave heating units located in each housing unit or in the general housing area are used to reheat entrees to an optimal temperature. Cafeteria-style food service also requires an area in the housing unit to line up the bulk food containers and distribute and collect the trays.

Other alternatives to consider are to provide thermally controlled carts for the trays. These carts can be brought to the housing units and plugged in to maintain the temperature of hot and cold items. Some facilities use cook-chill systems and provide retherm units in the housing areas to heat the meals so there is no problem maintaining meal temperatures. With this system, food is prepared in advance, then trays are assembled and placed in a blast chiller to cool to the proper storage temperature. When the food is to be served, the trays are placed in a retherm unit and distributed to the inmates either from a central location or in the housing area.

With the conventional approach of preparing food trays at the food service area and delivering them to the inmate housing units, the following considerations apply:



Cook-chill cooking and bagging system.

(Photograph courtesy of Voorhis Robertson Justice Services.)

- Providing sufficient surface area or tray assembly equipment (such as assembly lines) to allow rapid tray assembly and preparation for insulated delivery.
- Providing storage and cleaning areas for carts used in delivery.
- Coordinating the food tray size with the size of food passthroughs used to serve inmates when they must eat in their cells (e.g., disciplinary detention).
- Providing food passthroughs into the dayrooms to allow serving the meal in higher security units without opening the door.
- Providing a means to distribute beverages effectively (e.g., fill cups and distribute through a food pass or place a large beverage dispenser in the housing unit for inmates to serve themselves).
- Providing a means by which to count, distribute, collect, and recount utensils, trays, and cups.

Section 3:
Functional Components

- Providing a means by which to collect waste (everything returned on the tray, or a waste can in housing units for later collection).

Food Preparation and Storage

ISSUE: Food preparation and storage area size and layout should be adequate to allow for the efficient preparation and assembly of meals.

RESPONSE: The sizes of the food preparation and storage areas are influenced by five primary factors:

- Types of meals prepared.
- Storage capacity.
- Flow/efficiency.
- Tray assembly approach.
- Expansion capabilities.

Size is determined as much by the type of food to be prepared as by the number of meals to be served. Buying bulk commodities and fresh produce increases the storage requirements for



Dry storage area in a small jail kitchen.
(Photograph courtesy of Jim Rowenhorst.)

a kitchen and frequently requires more equipment (e.g., refrigerators, slicer, vegetable shredders, bread ovens). Retaining the services of a dietitian and a food service consultant during the facility planning stages can assist in developing and coordinating menus with food purchasing options and required food preparation equipment.

The design of the kitchen should emphasize efficient production and assembly of food from storage to preparation, cooking, and serving. This production flow for food preparation should be reflected in the design layout and should minimize cross traffic patterns for maximum efficiency (exhibit 22-2).

Special consideration should be given to convenient tray assembly procedures, a typical problem in many jail kitchens. Ample work surfaces on which to place the trays prior to placement on a cart, or the provision of a conveyor belt assembly line for rapid tray assembly and immediate placement on a cart, are practical solutions to this problem. It should be noted, however, that tray assembly systems sometimes require numbers of inmate workers or staff that may not be available in a smaller jail.

Deciding on the size of the kitchen should also include consideration of future expansion of bed capacity. Although kitchen spaces can be located along an exterior wall to allow expansion, this

Exhibit 22-2. Production Flow for Food Preparation

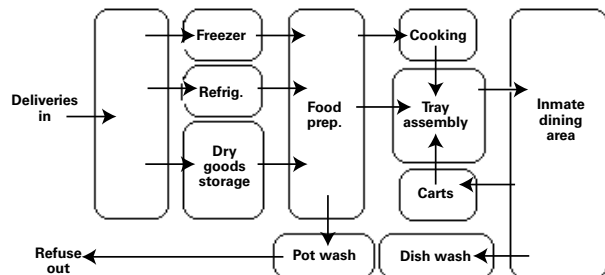

is sometimes an impractical alternative, given frequently limited growth needs and the disruption to existing equipment and functional space arrangements that must operate during renovation (preparation areas, cooking areas, tray assembly areas, dishwashing areas). Oversizing the kitchen and storage areas for a future expanded capacity usually requires only a modest increase in floor area and provides the operators with welcome initial flexibility in storage and work areas.

In determining the size of the food service area, consideration should be given to providing meals to other facilities (e.g., local juvenile detention and detoxification facilities). Some jurisdictions have consolidated the food service areas of one or more facilities in the new jail. Cost savings are realized by eliminating duplication of facilities, equipment, maintenance, and cooking staff and by reducing food purchase costs by buying larger quantities.

Cleanup and Waste Handling

ISSUE: Adequate provisions must be made for cleanup and waste handling.

RESPONSE: Most health department regulations require institutional kitchens to provide specific wash and rinse water temperatures. These criteria are best met by institutional dishwashing machines. A professional food service equipment consultant can assist in selecting an adequately sized washer and coordinating related needs for hot water boosters, grease traps, and so forth.

The need to wash pots, pans, and cutlery used in food preparation is similar to that in kitchens in other facilities and should be accommodated accordingly. Other cleaning needs can vary widely, depending largely on whether disposable or reusable items are used. For reusable items, special cleaning equipment (e.g., special racks,

deep sinks) may be required because of the special character of insulated plastic trays, plastic or metal cups, large insulated beverage dispensers, etc.

An adequate storage area for trays, utensils, food carts, and other reusable items should be readily available near the cleanup and food preparation areas.

Waste handling considerations include the following:

- Gathering waste from kitchen and dining areas.
- Sorting out items for recycling.
- Disposing of food waste.
- Disposing of boxes, cartons, cans, drums.
- Calculating the frequency and volume of trash removal (perhaps integrated with trash removal for all facility waste, such as paper and supplies).
- Providing a trash compactor, as appropriate.
- Temporarily storing trash until removal can be securely and conveniently executed, which may involve (1) a separate space or area to contain offensive odors and maintain the sanitation of the food service area and/or (2) a waste refrigerator for meat, fat, and fish scraps.

Food Delivery

ISSUE: The need to accommodate periodic food deliveries and use inmates to transfer these supplies to storage areas can create a weak point in the jail security perimeter.

RESPONSE: The jail should have a delivery area/loading dock that functions like a security vestibule (exhibit 22-3). Controlled by master control, food deliveries are unloaded into this area. Before the delivery person

Section 3: Functional Components

Exhibit 22-3. Jail Delivery Vestibule/
Loading Dock

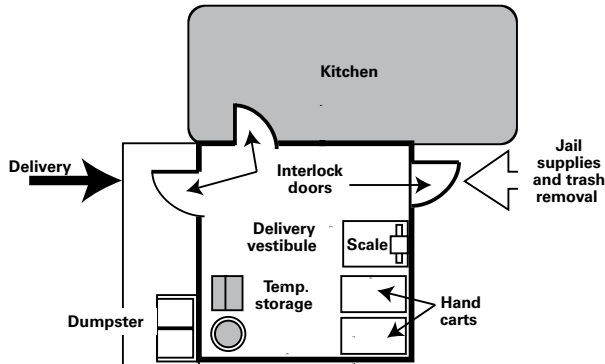

leaves, the food service staff verify the contents of the delivery, weigh items sold by weight, test the temperature of frozen and chilled items, and check containers for damage and contamination. When the exterior door is secured, food service staff coordinate the transfer of foodstuffs to storage areas by inmate workers.

In sizing and designing the delivery vestibule/loading dock, the following issues should be considered:

- The method of delivery to determine whether a raised dock or lift is required.
- Temporary storage requirements during delivery.
- The need to store hand trucks and pallets.
- The type and size of access door(s) needed (e.g., overhead, double swinging).

It is preferable for the delivery vestibule/loading dock to be separate from the vehicle sallyport used for arrestee intake and release so that the security and availability of that vital area are not compromised.

Staff Accommodations

ISSUE: The needs of food service staff should be accommodated.

RESPONSE: The food service director (or chief cook) should have a work area at which to prepare menus, document meals served, and do other paperwork. This area typically takes the form of an enclosed office space. It should include, at a minimum, a work surface; chair; lockable file storage; telephone; computer terminal; and shelving for cookbooks, reference sources, manuals, and catalogs.

Food service staff should be provided with a locker area for clothing and valuables and toilet facilities adjacent to the food service area. Separate toilet facilities and a break room should be provided for inmate workers. Storage space, accessible to the food service director, should be provided for plastic gloves, hairnets, and other special articles of clothing used by food preparers.

Security

ISSUE: Security precautions must be taken if inmates work in the kitchen.

RESPONSE: Cutlery should be regularly inventoried and stored in a lockable cabinet or closet with the key securely retained by the food service director and shift commanders. Knives should be individually checked out as needed by kitchen staff and can be secured to the preparation tables by lockable tethers before inmates are allowed access to them. To avoid inmate workers being pressured by other inmates to smuggle contraband from the kitchen, most jails provide a separate housing unit for inmate workers, which is strongly recommended. Some jails totally separate that unit from the

other housing areas, although care must be taken not to sacrifice necessary supervision by doing so. (Inmate worker housing and separation issues are addressed in chapter 16, “Special Housing,” and also in chapter 5, “Classification/Separation,” in section 2.)

General security precautions for the kitchen area should include alarm and/or audio monitoring—and possibly closed-circuit television monitoring—by master control and/or windows at main corridors that permit staff observation. Kitchen staff should be able to easily summon assistance via portable radio, personal alarm, or panic button.

The food preparation and cleanup areas should be visible from the food service director’s work area/office, if possible. Also, the arrangement of counters and equipment should minimally obscure the food service director’s and/or the security staff’s view, depending on who has the principal responsibility for directly monitoring food service area activities.

Inmate Workers

ISSUE: A dining area for inmate workers may need to be accommodated as part of the food service component.

RESPONSE: When centralized dining is not provided, inmate workers can return to their housing unit to eat. However, it may be more convenient to provide a small dining/break area for them, as well as for food service staff, as part of the food service component. Options for providing this capability are as follows:

- Creating an adjacent, enclosed dining/break room.
- Creating an alcove or open area immediately adjacent to the food service area.

Creating an enclosed area has the benefit of securely containing the inmates, separating them from food service equipment, and providing more sanitary conditions. Depending on its location, however, it may place them in a setting that is less able to be supervised and may require more space than the other option.

Staff Dining Area

ISSUE: A dining area for staff may need to be accommodated as part of the food service component.

RESPONSE: Space often is made available adjacent to the food preparation area for dining space for staff members. The proximity to the kitchen allows for easy service of meals if they are provided for staff members. If meals are not provided, it can still be a space with a refrigerator, microwave, and vending machines that staff can use for meal breaks.



Staff dining area in a large jail with both indoor and outdoor dining.
(Photograph courtesy of Voorhis Robertson Justice Services.)

Section 3:
Functional Components

Space List

Some of the typical spaces that might be found within the food service component follow.

- Receiving dock.
- Delivery vestibule/loading dock.
- Security vestibule.
- Food storage:
 - Dry.
 - Refrigerated.
 - Frozen.
- Food preparation.
- Tray assembly.
- Secure cutlery storage.
- Cook’s work area/office.
- Cart storage and cleaning.
- Cleanup (pot washing, dishwashing).
- Tray/utensil storage.
- Central dining.
- Inmate worker/staff dining.
- Staff locker area.
- Staff toilet.
- Inmate worker toilet.
- Waste disposal.
- Temporary garbage retention.
- Recycling area.

Local codes and Americans with Disabilities Act guidelines regarding accessibility requirements should be consulted when planning these spaces.

Relationships and Components

Exhibit 22-4. Relationship of Food Service Area Components

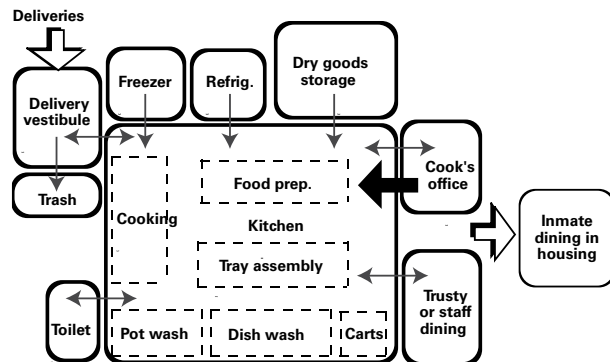
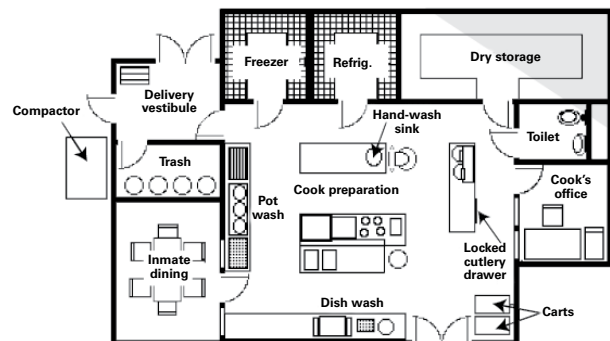

Exhibit 22-5. Sample Food Service Area



Chapter 23

Laundry Area

The jail laundry should be adequate in size and contain equipment for the laundering of bedding, linen, towels, and clothing on a scheduled basis consistent with standards and good correctional practice. In addition, laundry facilities should provide for cleaning soiled clothes removed from arrestees at intake.

Laundry facilities in most jails tend to be staffed by inmate workers responsible for all clothing, linen, and bedding used in the system. The work flow typically follows this pattern: collection, sorting, washing, drying, folding, mending, storage, and distribution.

In older jails, laundry areas were often quite modest, frequently located outside of the security perimeter in such areas as basements, corridors, or the sheriff's residence. The laundry areas provided little room in which to work and were rarely adjacent to key areas, such as the intake-release area, or readily observable by jail security staff.

In newer facilities, laundries tend to be easily accessible, dedicated laundry spaces that are used—sometimes on a 24-hour basis, in large facilities—to provide inmates with a continuous supply of clean clothing and bedding. Commercial equipment tends to be preferred over residential equipment because of its larger capacity and longer life.

Key Decisions

The following decisions have a fundamental effect on design requirements and should be made when the role of the laundry services component is evaluated:

- What range of items will be laundered, and how frequently?



Washers in a new laundry area with enough room to store laundry collection bins.

(Photograph courtesy of Jim Rowenhorst.)

- Will laundry services be provided in-house or by outside sources?
- Will inmates assist in laundry operations and, if so, to what extent?
- How many hours a week will the laundry need to operate?
- Will any inmate classifications be responsible for laundering some or all of their own clothing and linens (e.g., work release inmates)? Will this take place in a separate laundry area?

Detail Issues

The following detailed functional-architectural issues should be considered in the development of the laundry component: laundry provider, security/location, size, work/storage, and characteristics. Linen and clothing storage issues are addressed in chapter 14, “Intake-Release.”

Laundry Provider

ISSUE: A choice must be made between providing laundry services in-house or contracting with outside sources.

RESPONSE: Contracting for laundry services will slightly reduce overall construction and project costs. The main advantage to contracting laundry services is reduced long-term maintenance and fewer operational problems. To determine the best course to take, a local jurisdiction needs to compare the savings in construction, equipment, supplies, and staffing costs with the annual costs of outside service, the possible need for extra storage capacity for clothing and linens (potentially due to less frequent deliveries and less adaptability to unusual situations), and the possibility for introduction of contraband from outside the facility.

Inmate workers are commonly assigned to assist with laundry services to minimize the cost and to help justify providing in-house laundry services (beyond citing the obvious convenience and control it provides). However, the use of inmate workers has not been without problems, for example, inmate use of inappropriate amounts of detergent or bleach, the premature need to replace laundry equipment and clothing due to misuse or vandalism, and difficulties in monitoring and supervising small groups of inmate workers. The problem of using incorrect amounts of detergent and bleach is easily addressed by planning for secure storage of these items and automated dispensing directly into the machines through the use of preprogrammed dispensing systems.

Another consideration in smaller jails is the possibility of the jail consistently having enough inmates who can be classified for inmate worker status. Inmate populations can vary widely,



and there may be times when no inmate could be safely classified for these duties. These problems, when combined, may suggest that a contract service makes sense, especially if the jail can be assured that adequate clean clothing and linens will always be on hand and will be delivered in a secure fashion.

Security Location

ISSUE: The laundry must be located so as to ensure adequate security and appropriate access.

RESPONSE: When inmate workers help with laundry services, the laundry must be within the security envelope of the jail, which is advisable in any case. Because the noise and residual moisture of a laundry operation can hamper the use of electronic monitoring devices, it is important to locate the laundry so that observation of the area can be maintained from a constantly staffed post, or at least from outside the space by a passing officer. Additionally, blind spots in the arrangement of the equipment should be minimized or eliminated to facilitate remote observation. Two-way intercoms should be provided in the space for communication between staff and inmate workers.

Ideally, the laundry location should be:

- Adjacent to storage areas for clean facility clothing and linens and blankets.
- Easily accessible from the housing units.
- Near or adjacent to inmate worker housing.

Size

ISSUE: The size and complexity of the laundry depend on the frequency of cleaning and the variety of laundry services offered.

RESPONSE: A primary determinant of overall laundry area needs is the frequency with which items are cleaned. Most professional standards recommend an exchange of clean clothing, linen, and bedding a minimum of once each week. This minimum is exceeded by many facilities, especially for clothing and towel service. Frequent laundry service can help achieve the goal of good inmate hygiene and facility cleanliness.

Few older facilities launder street clothing removed from inmates during intake processing, although street clothing can present odor, mildew, and parasite problems. Spray disinfectants may partially solve these problems, but laundering is a preferable and effective solution, and its impact on equipment and space needs should be considered, even if used for only extremely soiled clothing.

Other laundry activities that can affect space and equipment needs include:

- Dry cleaning.
- Garment repair or mending.
- Ironing or pressing.
- Kitchen towel laundering.
- Special laundering (e.g., heavily soiled work uniforms from vocational training or work programs).
- Work release laundering.
- Female personal laundering.

To prevent contraband passage, separate laundry facilities for work release inmates should be considered (exhibit 23-1). These additional facilities preferably would be part of the work release housing unit and directly accessible to the inmates. It is desirable to place the equipment in a separate room where moisture and sound can be better contained. The space should have good ventilation, a floor drain, and be observable by staff from a remote point.

If work release inmates are not permitted to wear personal clothing within the security envelope, a laundry outside the security envelope should be considered for the laundering of personal clothing they wear to work. This laundry may contain coin-operated washers and dryers, and vending

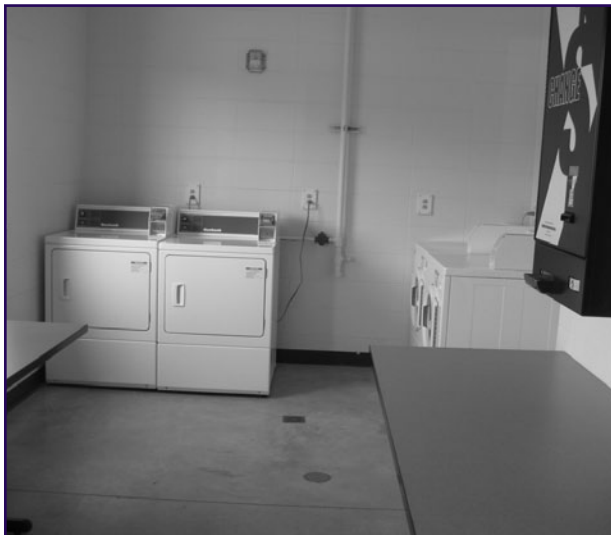

A separate work release laundry in the work release housing area. Notice that the equipment is coin operated. (Photograph courtesy of Jim Rowenhorst.)

Exhibit 23-1. Location of Separate Laundry Facilities for Work Release Inmates

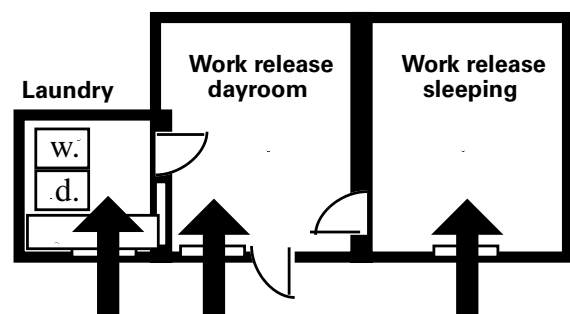

**Section 3:
Functional Components**

machines for soap and fabric softener. It should be located within the facility near the work release entrance and observable by staff from a remote point.

ISSUE: The sizes and types of washers and dryers depend on the amount and type of laundering to be done and the number of hours the laundry will operate.

RESPONSE: Except in very small jails, residential or lightweight commercial machines are inadequate and insufficiently durable to handle the variety and amount of laundering required. The daily use of this equipment and the frequent need to wash heavy loads such as blankets and shoes generally recommend the use of heavy-duty, commercial-grade laundry equipment. To identify actual equipment needs, an estimate of the amount of laundry to be processed each hour must be calculated by weight.

First, the weight of laundry to be done for each inmate per week is calculated. This is done by identifying each article issued to an inmate, its weight, and the frequency with which it will be laundered in a week. Items issued to inmates may include uniforms, underclothes, socks, bed linens, towels, washcloths, coats, and shoes. The weight of each item can be determined by simply weighing a typical item on a scale.

The weekly laundry poundage for each inmate is multiplied by the projected jail bed capacity, or peak population estimate, to determine the facility's entire weekly laundry needs. The weekly laundry poundage is then adjusted to account for the fact that washers are not typically loaded to capacity. Generally, they work best at 75 percent of their rated capacity.

The adjusted weekly laundry poundage is then divided by the number of hours per week the laundry will operate to determine the amount of

laundry to be processed each hour. Assume that inmate workers can complete one load of laundry per hour. Generally, the more hours the laundry operates, the smaller the size of the equipment needed. The formula for calculating washing capacity is as follows:

$$\frac{\text{Pounds laundry per inmate} \times \text{laundryings per week} \times \text{peak population}}{\text{Hours/week of operation} \times 75\% \text{ efficiency}} = \text{Pounds washing capacity needed}$$

For example:

$$\frac{10 \text{ pounds laundry per inmate} \times 3 \text{ laundryings per week} \times 100 \text{ inmates}}{40 \text{ hours/week operation} \times 75\% \text{ efficiency}} = 100 \text{ pounds washing capacity}$$

After the amount of laundry to be processed each hour is determined, the equipment can be selected. When choosing equipment, select at least two sets of washers and dryers to permit laundering different types of articles at the same time and to provide at least one working washer or dryer if one breaks down. The combined capacity of the washers should exceed the hourly capacity needs, and the dryers should have a capacity slightly larger than the washers to account for moisture in the laundry articles.

If the number of items laundered and/or the frequency of laundering changes, a factor must be applied to the formula to account for the change.

The future expansion of bed capacity should also be considered in planning. Expansion can be accommodated by oversizing equipment, providing space and plumbing for additional equipment, or increasing the number of hours of operation.

Corridor and doorway widths should be coordinated to allow passage of repaired or replacement equipment.

Work/Storage

ISSUE: Adequate area must be provided for washers, dryers, work space, and supply storage.

RESPONSE: In addition to washing and drying equipment, space may be required for:

- Dry cleaning.
- Folding tables.
- Laundry carts (separate carts or compartments for soiled and clean laundry).
- Laundry tubs (presoaking).
- Supply storage.
- Ironing or pressing.
- Mending.
- Laundry scale.
- Temporary storage of clean linen and clothing until it can be moved to appropriate separate areas.

It may also be wise to consider providing automatic chemical dispensing equipment if inmates work in the laundry. This equipment helps eliminate the problem of using inappropriate amounts of detergent, fabric softeners, or bleach. Although this equipment costs more, it may be worth the additional expense.

Characteristics

ISSUE: The laundry area should have special design characteristics appropriate to its needs.

RESPONSE: Some special design characteristics to consider when designing a laundry area include:



Shelves for the storage of clean laundry and shoes in the laundry area.
(Photograph courtesy of Voorhis Robertson Justice Services.)

- An excellent ventilation system that exhausts moisture and excessive heat directly to the outside.
- Adequate floor drains.
- Trough to accommodate discharge of water from washers.
- Janitor's floor sink for mopping up spills.
- Non-slip floor surfaces.
- Fire detection, suppression, and evacuation systems.
- Moisture-resistant surfaces.
- Small desk.
- Water fountain.
- Inmate worker toilet and sink.
- Television or radio for the inmate workers who may spend long hours in the laundry area.

Space List

Some of the typical spaces that might be found with the laundry component include:

- Main laundry room:
 - Cart staging area.
 - Sorting and weighing area.
 - Washing machines.
 - Dryers.
 - Folding tables.
- Detergent-bleach dispenser room.
- Linen and clothing storage room.
- Supply storage closet.
- Inmate worker toilet room.
- Laundry at work release.
- Laundry at female housing.

Local codes and Americans with Disabilities Act guidelines regarding accessibility requirements should be consulted when planning these spaces. Basic laundry spaces are typically closely affiliated with the intake-release area.

Relationships and Components

Exhibit 23-2. Relationship of Laundry Components

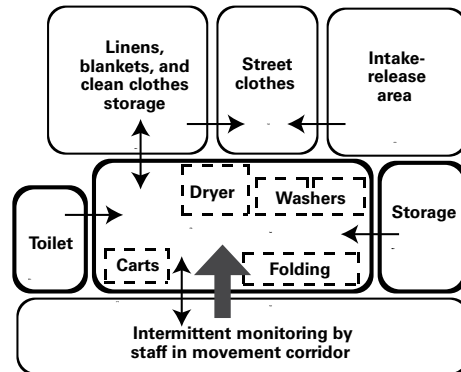
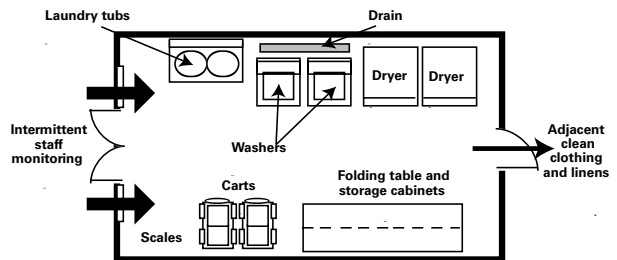

Exhibit 23-3. Sample Laundry Area



Administration and Public Areas

The jail's administration and public reception areas are essential to the organization and management of daily business within the facility. They are also essential to accommodate the public's need for access to the facility and other aspects of the jail operation. The various activities performed in these areas are:

- Establishing and ensuring the execution of operational and security policies and procedures.
- Managing the business affairs of the jail, including general accounting, ordering supplies and goods, and managing inmate accounts and bond moneys.
- Maintaining essential records, with the possible exception of medical and classification records.
- Receiving and distributing moneys, mail, packages, and clothing for inmates.
- Conducting inventories of all facility supplies and equipment.
- Managing personnel, including the organization of training, daily briefings, and incidental meetings.
- Dealing with the public in person and by mail and telephone.
- Accommodating outside groups for tours and presentations.
- Responding to requests for information and reports from county commissioners and other officials.
- Meeting with local media personnel.
- Storing miscellaneous supplies related to administrative functions.
- Conferring with other criminal justice system officials.

Older jails usually lack work spaces for administrative staff, records functions, and for meeting with the public. In some jails, administrative office areas were created out of corridor space or niches in basement areas. Record storage was sometimes accommodated by using a much-needed jail cell. The public frequently penetrated the security perimeter to reach law enforcement dispatch or jail office areas that were used for public reception.

With the increased emphasis on professional jail administration and the need to accommodate public contact, administration and public areas are receiving more attention when new jails are designed. However, the adequacy of administrative/public space can still be a problem that may not get the attention it deserves during planning and design. This deficiency may result from oversights by the planning team or from an inclination to reduce administration and staff areas when jail budgets are limited.

Many diverse spaces are associated with the administration/public component and typically include:

- Public lobby and related spaces (public toilets and lockers).
- Public reception area.
- Administrative staff offices.
- Conference and meeting areas.
- Administrative support areas, including space to maintain records and perform necessary work.
- General supply storage space.
- Staff toilets.
- Janitor's closet.

Key Decisions

As the role of the administration/public component is evaluated, the following decisions should be made because they have a fundamental impact on design requirements:

- Will jail administration, support staff, and public reception functions be merged with those of law enforcement? What areas will they share (e.g., a common lobby)?
- How and by whom will public reception and outside telephone calls be handled during normal office hours and after office hours?
- How will mail, packages, clothing, and other items be received and managed?
- Will the administration area be within the main security perimeter of the jail? If so, will the public enter the security perimeter to meet with jail administrative staff?
- Will offices for program and service staff be located in the administration area near program areas in the jail?

Detail Issues

The following issues should be considered in the development of the administration/public component: location/arrangement, lobby/reception, administrative support/work areas, administrator's office, conference areas, and security equipment.

Location/Arrangement

ISSUE: The administration component should be accessible to both the public and the inmate-occupied areas of the jail without creating security conflicts.

RESPONSE: Administrative staff interact with the public, salespeople, the media, and other official visitors on a daily basis. Therefore, access to the administration area must

be convenient and as direct as possible.

This essentially means that administrative offices, meeting rooms, and the public lobby must be adjacent to each other.

It is also important for the lobby area to be adjacent to the inmate visiting area or the access point to the visiting area. This not only facilitates the regular visiting process but is necessary in facilities where standards require immediate postarrest contact between inmates and family members, friends, attorneys, and bondspersons. This visiting access must be provided 24 hours a day, 7 days a week.

Public access to administration areas should be controlled in order to protect staff and to safeguard confidential records in the area. Such control can be attained by:

- Creating a security door between the public and administration areas.
- Providing protected reception counters or areas.
- If an open reception counter is used, providing a means by which it can be secured after office hours and transferring reception responsibilities to a secure space such as master control.

Separate Administration Area From Jail Perimeter

Since the public should not have access to the jail security perimeter, a good way to provide both proper location and security is to locate the administration area outside the main security perimeter but adjacent to it (exhibit 24-1). The need for this separation becomes more important if jail administrative functions (e.g., administrative support services, records) are merged with law enforcement functions, since law enforcement personnel should generally be separated from inmate areas.

Exhibit 24-1. Administration Area in Relationship to Security Perimeter

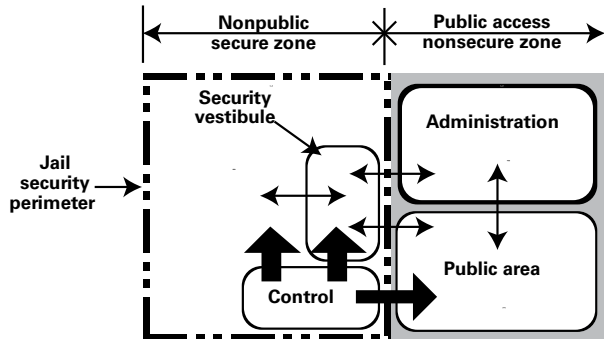

Although separating administrative areas from the security perimeter is a good principle, it may pose a logistical problem for the small jail administrator whose frequent presence within the jail is required. In smaller jails the administrator may be integrally involved in providing staff supervision or even security and services to inmates because of staff limitations.



Placement of the small jail administrator's office outside the security perimeter could cause considerable inconvenience to the jail administrator who must perform line-officer duties. The following concepts should be considered to address this problem:

- The jail administrator's office might be located just inside the inmate-occupied part of the perimeter and adjacent to the facility's administrative support areas located outside the perimeter. A secure passthrough between the two areas would allow the jail administrator and administrative support staff to transfer documents without continuously having to penetrate the security vestibule of the perimeter.
- The jail administrator's office might be situated just outside the primary jail security perimeter and a secondary desk or work area,

with file storage, could be located within the perimeter.

The approach taken to this problem depends on the frequency of public contact with the jail administrator, the jail administrator's need for direct contact with administrative support staff and access to records, and the degree to which the jail administrator performs fundamental security tasks.

ISSUE: The administration area should be linked with other functional components with which it frequently interacts.

RESPONSE:

- It is desirable to locate the staff areas and the administration areas adjacent to each other for the following reasons:
 - Convenience for attending staff briefings.
 - Enhanced management of staff activities.
 - A common need to be in an area secured from the public, yet outside the main security perimeter of the jail.
 - Sharing of spaces such as multipurpose, training, and conference rooms.
- All jails, regardless of size, can use a meeting or conference space in the administration area to hold meetings with the public. Administration areas, particularly the records area, should be as accessible as possible to master control/dispatch and the intake-release areas for the convenient transfer of records. This is especially true in cases where computerized data systems are limited or not in use and hardcopy records must be transferred. Unless so located, jail staff will be forced to deliver files to intake-release

Section 3: Functional Components

at inopportune times or maintain active records in that area instead of in a central records location.

- Administrative staff should be able to enter their area quickly and directly from their parking areas. Access can be gained through the public lobby or, preferably, through a separate staff entrance.
- Direct access from the outside into individual administrative offices, such as the administrator's office, is discouraged because this poses additional security and surveillance problems. It should be recognized that acts of violence may be directed toward administrative staff. As a rule, the number of openings into any perimeter should be minimized.
- Administrative and public areas should be located so they can be expanded as facility operations grow, or the facility should be planned with surplus offices and space in which to grow.

Lobby/Reception

ISSUE: A lobby and reception area should be provided to properly and effectively accommodate contact with the public.

RESPONSE: The public lobby is the primary point of contact for all public and official visitors to the jail. A visitor's impression of the lobby and reception areas will greatly influence the jail's image in the community and the reaction of visitors to jail staff.

The following characteristics should be considered in developing the lobby and reception areas:

- The lobby area should be sized to provide at least 15 square feet for each person expected

to use the area at one time. A more generous allocation of space is encouraged to enhance public use and impressions of the area. To determine the number of individuals who will use the lobby area, it is important to decide whether the lobby will be used only for inmate visitors or whether it must also accommodate visitors waiting for general business purposes, attorneys waiting for visits with inmates, law enforcement, or other criminal justice functions associated with the jail. Allowances might also be made for large groups that come to the jail for tours or presentations about jail activities, such as county commissioners, citizen committees, and grand juries.

- Acoustic treatment should be provided to improve the quality of the space, especially when large groups with children are in the area.
- Sound separation between the lobby and adjacent jail administration and jail security areas is important.



A lobby area in a large county jail. Notice the open reception desk on the left and bench seating in the foreground.

(Photograph courtesy of Jim Rowenhorst.)

- The lobby space should be pleasant and comfortable, with natural light if possible.
- The reception area should be readily accessible and visible to the visitor. It is advantageous for the visitor to be able to establish eye contact with the reception staff immediately upon entering the jail.
- The lobby area sets the tone for the public's experience at the facility. The lobby should always be comfortable, clean, and well organized, and reception staff should be cordial and helpful.
- View conflicts between the lobby area and the jail perimeter should be avoided while still allowing direct eye contact between the reception staff and the visitor.
- To facilitate contact with the public, personnel working in the reception area must be able to communicate with all staff in their offices or posts throughout the jail. This allows quick response to public needs that can be filled only by other staff in the jail.
- A full-time receptionist (support staff or officer) performs all reception functions.
- Master control performs all reception functions (this can only be accomplished in smaller facilities where the master control officer has fewer tasks).
- A law enforcement dispatcher performs all reception functions.
- A receptionist or member of administrative support staff performs weekday reception functions, and master control and/or dispatch performs nighttime and weekend reception functions.

Around-the-clock reception

ISSUE: A method of accommodating contact with the public 24 hours a day, 7 days a week must be established.

RESPONSE: The public will need to have contact with the jail 24 hours a day, 7 days a week. Such contact might be made by inmates' family members, bondspersons, attorneys, and others who need communication outside of a standard 9 a.m. to 5 p.m., Monday to Friday schedule. Consequently, it is important to determine who will perform reception duties for the facility at all hours of the day and during the weekends. The basic options include:

Visitation presents the potential for high emotions and security problems. During visitation, any nonsecurity personnel at the reception post should have access to immediate assistance from a deputy or security officer.

Secure and controlled nighttime and weekend reception can be achieved by creating a night lobby or vestibule to which the public can gain access without penetrating the main lobby (exhibit 24-2). Preferably, such a night lobby will be adjacent to a staff post such as master control, the dispatch area, or the records area so that public needs can be dealt with directly and securely. In the event a night lobby area cannot be directly viewed by master control, it will be necessary to install a closed-circuit television (CCTV) and audio communications link to the area. Regardless of location, some form of passthrough opening should enable those coming to the jail to transfer material to master control or to the dispatcher without having the officer leave the secure post.

If the night reception post cannot be located adjacent to the night lobby, the design should establish visibility between the reception area and the public in the night lobby, if possible. If this is

Section 3: Functional Components

not possible, staff should have video monitoring capability of the night lobby. Staff should also be able to monitor the main lobby in the event a visitor needs to enter this area for any reason. Audio communications should also be provided. Nighttime control staff should be able to unlock the door that separates the main lobby from the night lobby by remote control.

Receiving packages

ISSUE: The means by which packages, clothing, money, and other items are received from the public should be secure and convenient.

RESPONSE: The public will bring a variety of items to the facility for inmates' use. They may bring clothing that will be worn for court appearances, cash, or personal items, as permitted by jail rules. These materials can be received securely received in the following ways:

- There may be a secure package or paper passthrough in the wall of a secure reception area. If the reception point is master control, the package passthrough raises a security concern about explosives, chemical and biological agents, or other items that would

Exhibit 24-2. Secure Reception Area

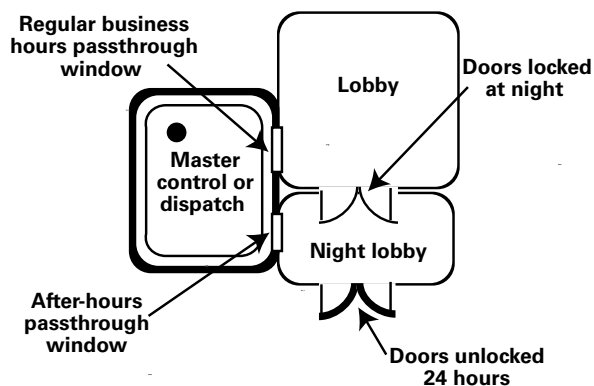

Night lobby in a small facility.
(Photograph courtesy of Kimme & Associates.)

endanger control staff and the facility in general.

- Facility staff could leave the security perimeter to receive and screen the contents of the items before allowing them within the security perimeter. This method is inconvenient for staff and takes them away from other security duties.
- Administrative support staff or dedicated reception staff could accept materials only during the day. The security staff would then leave the perimeter at a convenient time to receive and check the materials prior to final acceptance.

A combination of these approaches might best satisfy reception needs. Some jails have used x-ray screening equipment for all packages and mail entering the facility.

Lobby support elements

ISSUE: Proper support space and equipment should be provided for the lobby area.



Receptionist's window with a sliding opening to receive items from the public.
(Photograph courtesy of Voorhis Robertson Justice Services.)



Public lockers and restroom in a small jail lobby.
(Photograph courtesy of Voorhis Robertson Justice Services.)

RESPONSE: Several space and equipment considerations should be made during the design of the lobby area, including the following:

- Public, accessible toilets for men and women.
- Drinking fountains.
- Telephone.
- Clock.
- A bulletin board or display case that communicates facility rules and practices relevant to the public.
- Durable but comfortable furniture with durable finishes.
- A locker area for the secure storage of coats and valuables (especially in connection with visiting—see chapter 18, “Visiting Areas”).
- If space allows, it is very desirable to have a small children’s table for using

crayons and coloring books or another type of play area for children who are waiting to visit inmates.

Administrative Support Work Areas

These are the work areas for administrative support and records staff and other miscellaneous functions associated with facility administration.

ISSUE: The basic activities of the administrative support staff should be determined to establish size and equipment requirements.

RESPONSE: The support staff area forms the core of the administration area. Fundamental functions are performed in this area, with some variations.

A primary variation concerns whether support staff will be involved in contacts with the public. If so, their space needs to be immediately adjacent to, and accessible from, the public lobby area. The method by which the public will be received should also be determined since it can be done either in a secure manner (e.g., visitors speaking through a secure telephone, intercom,

Section 3: Functional Components

or passthrough) or by having visitors approach or enter the administrative support area and speak directly with administrative support staff across a counter or desk.

It should also be determined whether the support staff will have the primary responsibility for answering telephone calls during the day. Answering calls for all parts of the facility can be time consuming and can eventually generate the need for additional staff. Most new facilities have some sort of “automated attendant” service on their phone line that directs calls to the appropriate person or function.

Clearly, the administrative workload must be carefully identified and assigned to positions prior to beginning design. Further discussion of administrative tasks and position assignments will occur during design to ensure an effective and efficient administrative component.

Administrative support staff typically perform the following activities:

- Typing or entering data.
- Maintaining files.
- Establishing and keeping records.
- Copying and collating reports and information.
- Logging and sorting mail.
- Maintaining accounts and purchasing.
- Controlling and managing inventory of facility office supplies.
- Transcribing dictated information.

Common types of equipment associated with typical administrative support activities include:

- Desk and chair for each staff person.
- Computer stand.

- Computer and printer.
- Copier.
- Work surface to collate copied reports and information or to screen, sort, and log mail.
- Postage scale.
- Binding machine.
- Telephone.
- Intercom unit.
- Transcribing machine and foot pedal.
- File cabinets.
- Wastebasket.
- Fax machine.
- Safe.

ISSUE: A variety of functions associated with the support work area may require separate space.

RESPONSE: Such areas are either provided within the administrative support area, an adjacent alcove, or an adjacent separate space.

- **Supply storage.** Storage space should be provided for pens, pencils, paper, copier supplies, printer cartridges, file folders, forms, and so forth. The size of this space depends on the range of items stored and the inventory maintained (a large file cabinet may be adequate in very small jails). If wholesale purchases of items such as customized forms and copier paper will be made from office supply distributors (because of cost considerations), a fairly significant amount of space might be needed to store office supplies. In larger jails these supplies are often stored in a main warehouse area

and used to stock various areas within the facility.

- **Inactive records storage.** A jail is frequently required to maintain files on inmates and general office matters, such as budget summaries, policy and procedure manuals, and so forth, for extended periods of time. When considering storage space for these archived records, it is important to choose an area accessible to the staff who would need those files. Generally, these sorts of files are kept in the administrative support area and do not need to be stored in the jail's main security perimeter. However, access to these files should be controlled.

A key determinant of storage needs is the life-span that defines "active" records (e.g., current and those generated in the past year) and "inactive" records (e.g., 1–40 years old). Depending on the time period covered and the volume of inactive files kept, some or all of them might be better stored in less valuable space outside the administrative area. Basement or attic space might be used as long as it has satisfactory environmental characteristics to preserve the integrity of the files (dry, well ventilated) and to allow for easy retrieval of the files. Many jurisdictions use offsite storage to maintain records in optimum conditions; staff assigned to the records storage function are able to retrieve these records as necessary. When designing space for records storage, it is essential to check laws regarding the retention of various types of records.

- Other approaches to maintaining inactive records include digitizing the information. A decision to computerize can greatly reduce the need for space in the administrative support and administrative areas for keeping inactive records. Digitized files may need a dedicated server to store the information.

- A closet area should be available to store the coats, purses, hats, and boots of administrative personnel and official visitors.
- Toilet facilities should be available for staff and should be easily accessible.
- Depending on whether there is a staff break-room, a small area for a coffee machine, microwave, and/or refrigerator might be provided.
- To maintain the acoustic integrity of the area, a separate space may be developed for equipment that generates noise, such as copy machines and computer printers.

Administrator's Office

ISSUE: The location of the jail administrator's office must be convenient both to the jail and to administrative support areas in the facility.

RESPONSE: As previously discussed, the jail administrator's office is closely related to the jail's administrative areas and primary security areas. If the jail administrator's office is within the jail security perimeter, it would be useful to be able to observe several key areas or the main circulation corridor from the space. Although the jail administrator's office may have a fair amount of glazing to permit observation, it should also have curtains or blinds to afford privacy in dealings with staff or inmates.

If the jail administrator's office is outside the security perimeter, the office should be large enough to accommodate small conferences (exhibit 24-3). If it is within the security perimeter, it should be immediately adjacent and accessible to a conference area.

ISSUE: The jail administrator's area should be designed to accommodate a variety of functional needs.

Exhibit 24-3. Jail Administrator's Office

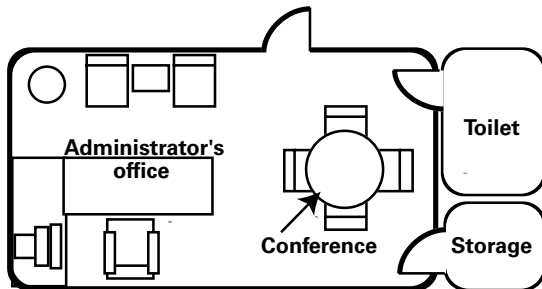

RESPONSE: Aside from the normal desk and seating requirements, a number of functional and equipment considerations influence the design of the jail administrator's area:

- A private toilet is desirable unless another one is located close to this area.
- A small, very secure storage closet is desirable. Security is essential because the closet might be used to store sensitive items such as audio tapes or evidence from disciplinary investigations.
- If the jail administrator's office is outside the security perimeter, it may be a repository for an extra set of facility keys that can be accessed in an emergency. If this is the case, the keys must be in a secure cabinet or safe, preferably in a secured space out of sight. A closet space within the jail administrator's area might be an appropriate place for a secure key cabinet.
- The windows of the jail administrator's office should have a burglar-resistant or detention-quality glazing to prevent vandalism or attacks from the outside.
- The space should have lockable file cabinets and drawers, especially if other administrative staff also use the

jail administrator's office as a nighttime command post or meeting center. Sometimes the administrator's office is the repository for personnel records (which must have restricted access).

- The door to the jail administrator's office should be lockable.
- The jail administrator's office must be equipped with both an inside telephone line or intercom system and an outside telephone line.
- The jail administrator's office must have the ability to provide visual and acoustic privacy. This is critical because the administrator often meets with inmates or staff about private matters. In providing acoustic privacy, be sure that sound does not transfer through ventilation systems or above the ceiling and into adjacent spaces.
- If the jail administrator is the recipient and caretaker of bond moneys, a safe or lockable deposit box would be advisable.
- The jail administrator may want CCTV monitors or the capability to accommodate them at a later date.
- If the primary method of communication between jail staff is portable radio, that same capability may be needed in the jail administrator's office.

Conference Areas

ISSUE: The conference area should have characteristics conducive to meeting activities.

RESPONSE: Conference space can be provided in several ways, including:

- A dedicated conference area (preferred).

- A conference area within a larger staff briefing/training/multipurpose room.
- An extension of the jail administrator's area for small conferences (preferred only as an addition to other conference space).

The conference area should have the following characteristics:

- Sufficient space to accommodate the number of people expected to use the area. Exhibit 24-4 shows an example of minimum square footage, which depends on actual equipment and furnishing needs.
- Sufficient wall surface for presentation boards, screens, marker boards, bulletin boards, and so forth.

Exhibit 24-4. Assumptions for Size of Conference Area

Number of Users	Room Size (square feet)
4-5	125
6-7	145
8-9	170
10-11	200
12-13	250
14-15	300
16-17	365
18-19	430
20-22	500

- Controllable and variable lighting arrangements.
- Proximity to the jail administrator's office, if possible.
- Storage area for audiovisual and other support equipment.
- Telephone, cable television, and data outlets.
- Good acoustical qualities.
- Natural light, if possible.

Security Equipment

ISSUE: Provisions must be made for storage of emergency response equipment.

RESPONSE: The facility will probably need to maintain a variety of security equipment, including:

- Helmets.
- Batons.
- Shields.
- Less-than-lethal munitions and ammunition.
- Chemical agents.

This equipment should be stored in a controllable area outside the jail's main security perimeter. There is no single best location, but common locations include:

- Secure armory in the vehicle sallyport.
- Sheriff's law enforcement weapons armory (if a joint facility).
- Secure armory in the jail's administration area (if outside the security perimeter).

Regardless of location, several characteristics of the security equipment storage space must be considered, including:

Section 3: Functional Components

- Secure and lockable door.
 - Security construction for the wall, floor, and ceiling.
 - Access limited to the jail administrator or law enforcement supervisors and other key jail personnel selected by the jail administrator (e.g., the special emergency response team).
 - Proximity briefing areas where officers might assemble in emergencies and be issued security equipment.
 - Detectors and alarms if chemical agents or ammunition are stored in the space.
 - Special ventilation if chemical agents are stored in the space.
 - Proper and accessible shelving and storage compartments for the equipment to be stored in the space.
- Copy room.
 - Administrator's office.
 - Shift commander.
 - Conference room.
 - Other staff offices (including spare offices).
 - Staff toilet.
 - Coat closet.
 - Inactive records.
 - Jail security equipment.
 - Technical service office.

- Public:
 - Public lobby.
 - Public toilet.
 - Public storage/locker area.
 - Night lobby.
 - Public reception desk.
 - Security vestibule (may be the same as the vestibule used for visiting access).
 - Parking.

Space List

Some of the typical spaces that might be found in the administration/public component follow.

- Administration:
 - Administrative support.
 - Supply storage.

Local codes and Americans with Disabilities Act guidelines regarding accessibility requirements should be consulted when planning these spaces.

Relationships and Components

Exhibit 24-5. Relationship of Administration Area to Jail Operations and Public Lobby

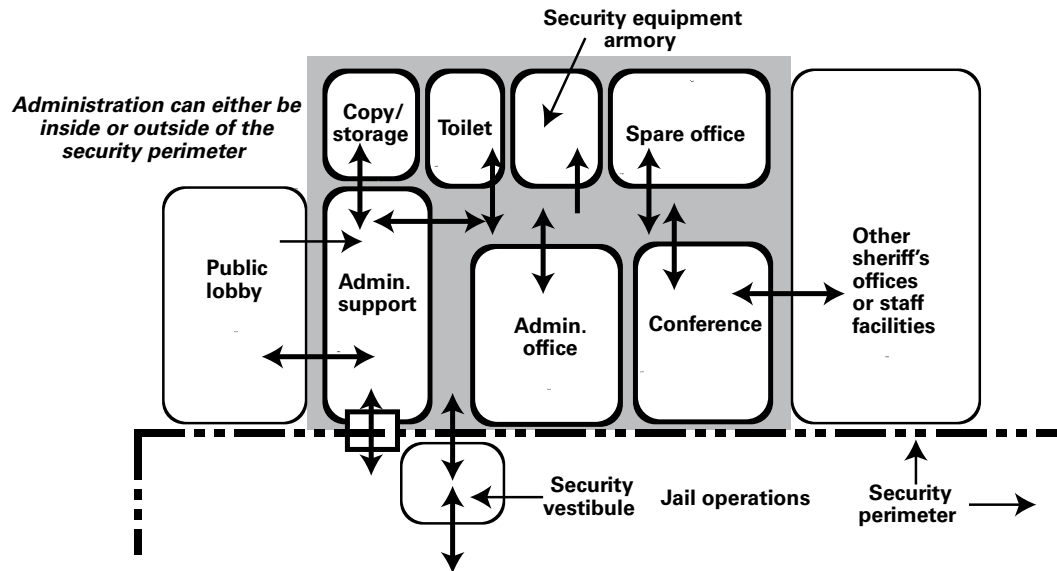
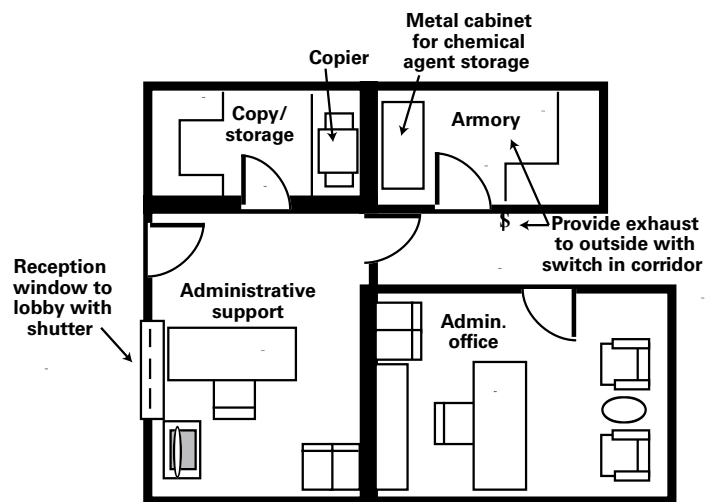

Exhibit 24-6. Components of Administration Area



No one spends more time in jail than the jail staff. Yet jails across the country have consistently neglected to address the needs of jail staff.

Motivation and management experts state there is growing evidence that corporations that fail to address staff needs send a clear message to their employees: “You don’t count around here!” By making an architectural statement that clearly recognizes and accommodates the needs of its jail staff, a local government can make a lasting contribution to positive employer-employee relations, staff morale, and productivity.

In this chapter, “staff areas” are defined as those spaces that are specifically intended for the private use of jail staff. These include a lounge or break room, training areas, exercise rooms, locker/shower rooms, and toilets. They do not include staff control posts, which are dealt with in chapter 13, “Master Control,” and chapter 15, “General Housing.”

Newly built jails around the country have some or all of the staff areas identified. Some smaller jails have cleverly consolidated some of the spaces under the heading of a staff “multipurpose” or “multiuse” room. It is not necessary to view every staff space as having a mutually exclusive purpose. The trick is to avoid taxing any one area with too much staff or traffic or with activities that are inappropriately combined, as in one small jail where the coffee room and weight room occupied the same space.

A key space-sharing concept in smaller jails is that of creating common staff areas for both law enforcement and jail personnel. With few exceptions, there is no substantial reason



to separate many of these areas. It is important, however, to consider providing equal accommodations for each to help avoid the age-old problem of perceiving law enforcement work as more important and desirable than jail work.

Key Decisions

The following decisions have a fundamental effect on design requirements and should be made when evaluating the role of staff areas:

- Will jail officers routinely change into uniforms at the facility? Will locker and shower areas be needed? Where will officers store coats, boots, hats, and articles that should not enter the security envelope (e.g., weapons, holsters, cell phones, pocket knives, and, perhaps, matches and lighters)?
- Will there be physical fitness requirements and defensive tactics training for officers that can be met or encouraged by providing proper facilities at the jail?
- Will staff receive regular or daily briefings on the previous shift’s activities and their responsibilities, or for other purposes?
- Will staff be allowed breaks away from their posts? Will they eat meals away from their posts? Does the administration want to encourage camaraderie by providing a place for staff to meet before or after work?
- Where will staff receive formal training? Will training be done at the jail or at a separate training facility?
- If the law enforcement function is in the same facility, which staff areas can be shared?

Detail Issues

The following detailed functional-architectural issues relate to the various functions and spaces that make up the private staff areas of the facility: general issues, locker/shower areas, physical conditioning area, break room, training/multipurpose area, toilets.

General Issues

ISSUE: Staff areas should be located outside the secure envelope of the jail.

RESPONSE: It is not in the best interests of jail security and operations to place staff areas within the security envelope because off-duty jail officers, and especially law enforcement officers, within the envelope can distract the attention of on-duty staff and inmates. Staff areas should be near and easily accessible to an access point in the secure perimeter to avoid unnecessary delay in moving into the jail.

The exceptions to this rule are staff dining or staff break areas served by the jail kitchen (but off limits to off-duty staff). These areas would need to be inside the security perimeter.

Staff areas are not public areas. Therefore, they need to be separate and secured from unwanted public traffic.

ISSUE: Staff parking and entry must be considered in the design.

RESPONSE: Providing adequate parking for staff is important. Doing so generally entails the following considerations:

- Sufficient parking to accommodate shift overlap needs so that personal and departmental vehicles are not left on the street or in places other than the staff parking area.

- Protected parking, or at least parking separate from the public and visitor parking areas.

Protected or separate parking recognizes the professional status of staff and guards against vandalism. It can be provided in several ways:

- Underground garages or above-grade structures, with or without a controlled access point, that provide protection from the weather.
- A fenced-in parking area behind a control gate.
- A separate area, less visible to the public, possibly with access controlled by a gate.

Staff should enter the jail through a staff-only entrance. When determining the location of the staff entrance, the following should be taken into consideration:

- The entry point is convenient to staff parking.
- Entry to the staff areas is secured and entry requires a proximity card issued to staff, a remote unlock from a dispatch center or master control, or a coded electric lock with keypad.
- There is a conveniently located place, such as a locker area, for staff to deposit weapons and personal belongings before entering the jail security envelope.
- If staff briefing/rollcall or training rooms are to be included in the design, they should be located near the staff locker rooms outside the secure perimeter.

Locker/Shower Areas

All facilities need to provide locker and shower space for staff. The size of the space and the amenities offered depend on the particulars of a given operation. Factors that contribute to the use of and need for this space include:

- Absence of any other space to secure personal property or clothing during the work shift.
- Provision of physical conditioning space and equipment within the facility.
- Policies that forbid uniformed staff from wearing their uniform to and from work.
- Need to change into civilian clothes for court.
- Potential for contact with soiled clothing or laundry or bodily fluids.
- Need for storage of extra uniforms or issued equipment.
- Requirements for staff to work overtime shifts.

Activities/characteristics

ISSUE: Space, equipment, hardware, and finishes should be appropriate for the activities and needs of the area.

RESPONSE: Locker/shower area activities are little different from those in conventional public facilities, such as a gym. They include:

- Dressing and undressing.
- Clothing exchange/storage of coats, hats, boots.
- Storage of spare uniforms.
- Storage of holsters, belts, and miscellaneous job-related paraphernalia, if not weapons.
- Storage of policy and procedure manuals (if not automated) and other documents.
- Grooming (counter, sink, and mirror are necessary).
- Showering and drying.
- Hand and face washing.

- Toilet.
- Temporary storage of clean and dirty towels.

When designing a locker/shower area, equipment, hardware, and finish considerations include:

- Shower stalls, with at least one offering accessibility for staff with disabilities.
- Drying area, preferably with seat and towel racks.
- Sinks.
- Toilets and urinals, accessible for staff with disabilities.
- Shelving for storage of towels, washcloths, and toiletries.
- Clothes hampers.
- Lockers and benches.
- Nonslip surfaces near the shower areas and waterproof, cleanable surfaces throughout.
- Mirrors.
- Mechanical ventilation sufficient for the area.
- Electric hand and hair dryers.
- Ample outlets at the sink/grooming area.
- Heat lamps.
- Bulletin board(s).

Female staff

ISSUE: Separate areas for female staff should be included in the design.

RESPONSE: Female officers are employed at jails in greater numbers than ever before. While female staff can clearly share break rooms, physical fitness, and training areas with male staff, they should be afforded the

Section 3: Functional Components

privacy of separate showers and locker areas. This area was often overlooked in older and smaller facilities and should be accommodated in new facilities.

Locker/shower area size

ISSUE: The size of the locker/shower areas depends on the number and flow of users and their basic equipment needs.

RESPONSE: In calculating equipment, and thus space needs, a significant difference between locker needs and other equipment needs must be recognized. The number of lockers is determined by the total number of staff projected to use the area. Each staff member should be assigned his/her own locker, and additional lockers should be planned for increases in staffing or other users. Other equipment needs are determined by the number of users at any one time. The difference recognizes that there are considerably more total staff under employment than there are at work at the jail at any one time or who may come to exercise at any one time. This is also true of law enforcement officers who may share the locker/shower area. (Chapter 7, “Staffing Impact,” in section 2 reviews the difference between staff totals and staff shift counts.)

The number of lockers and other equipment provided, and thus the amount of space required, may increase if administrative, clerical, and reserve staff use the exercise and/or locker room facilities. Often civilian staff can be assigned in the secure perimeter of the jail and will wear a uniform. They should be provided locker space to store extra uniforms and personal items that are not appropriate to be taken into the security envelope. If the only staff exercise area is in the jail, it is common for law enforcement staff to



Locker room in a smaller jail.
(Photograph courtesy of Liebert & Associates.)

share those facilities, and they may require spare lockers to use when they are in the facility.

Sufficient space to permit generously sized staff lockers is recommended. This is due to the variety of articles that might be stored, including:

- Uniforms.
- Authorized Tasers or chemical sprays.
- Cell phones.
- Hats, coats, boots, shoes.
- Extra socks, underwear.
- Civilian clothing.
- Equipment, such as holsters and pocket knives (guns and ammunition should be stored in designated gun lockers located outside of the secure envelop of the jail).
- Toiletries, medications.
- Books, manuals, personal papers.
- Other items issued or required by the agency.

A typical locker has:

- Ventilation through small louvers or perforations.
- A lockable latch.
- A shelf or shelves for hats, toiletries, manuals.
- Single-tier design for full-length garments.
- Sufficient width and depth to accommodate garments on a hanger (at least 21 inches deep).
- Hooks for towels or other garments.
- Bench seating adjacent to the lockers.

To facilitate access and cleaning, lockers can be elevated on a base (exhibit 25-1) or continue to the floor with additional storage on the bottom of the locker.

Physical Conditioning Area

Many jurisdictions require staff to meet minimum physical fitness standards. A good argument can be made that it is reasonable for those jurisdictions to provide staff space and equipment to facilitate regular exercise. The key to determining whether such a space is needed will be an evaluation of whether the level of usage and resultant benefits to the staff and the organization justify the expenditure. Provision of an exercise area and equipment will further necessitate a staff locker room.

Space size

ISSUE: The size of the area depends on the number of people using it and types of activities.

RESPONSE: The size of a physical conditioning area is influenced by the following factors:

- Total number of potential exercisers at any one time.

Exhibit 25-1. Lockers Elevated on a Base

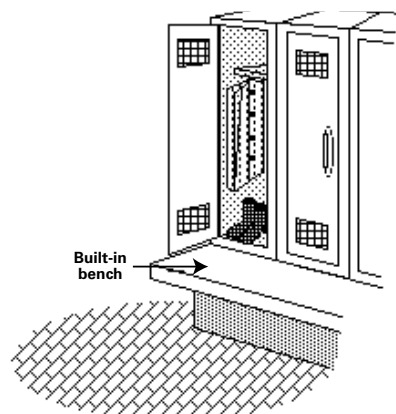

- Whether the area will be jointly used by both jail and law enforcement staff or other county employees.
- Type of activities accommodated in the area:
 - Basketball.
 - Weightlifting.
 - Martial arts training.
 - Calisthenics.
 - Aerobic/cardiovascular activities.
- Type of equipment required for the activities:
 - Basketball backboard, rim, and floor area.
 - Open floor space for self-defense activity mat.
 - Multiple-station exercise machine.
 - Station for free weights, including bench press.
 - Incline board.
 - Stationary bicycle.
 - Treadmill and/or elliptical machine.

Section 3: Functional Components

Chapter 19, “Exercise Areas,” provides further information on some of the space needs of these activities.

Access

ISSUE: A dedicated staff exercise area should be located outside of the security envelope.

RESPONSE: A dedicated staff exercise area should be designed so that staff can come and go without entering the security envelope. This is desirable because staff may want to exercise at odd hours and most jail administrators do not encourage off-duty staff to enter the security envelope after hours. Also, staff will be out of uniform and carrying gym bags, clothes, and other gear that could raise questions of contraband passage, as items accidentally left behind might be obtained by inmates. It would also be wise to consider placing the exercise area(s) as close to the point of staff access as possible to minimize staff movement.

Break Room/Dining Area

Staff need a place apart from the inmate population to eat meals and take other approved breaks during the shift. In addition, space should be provided to store meals, snacks, and soft drinks. (Staff dining is also discussed in chapter 22, “Food Service.”)

Break room size

ISSUE: The size of the staff break room/dining area depends on the activities, users, and equipment involved.

RESPONSE: Activities that typically occur in a break room include the following:

- Storage of personal meals and foodstuffs.
- Soft drink and snack vending.

- Refrigeration of perishable meals and snacks brought from home.
- Eating of meals.
- Recreational reading.
- Conversation.
- “Time-outs” or stress-reducing breaks.
- Preparation of hot and cold beverages.
- Limited meal preparation (warming, toasting).

Equipment and furnishings for which space may be needed include:

- Tables and chairs.
- Sink (gooseneck faucet for easy filling).
- Countertops.
- Drawers for utensils.
- Storage for cleaning supplies, cups, dishes.
- Kitchen appliances (coffeemaker, toaster, microwave).
- Hot plate or countertop stove elements.
- Under-cabinet lighting.
- Electrical outlets near counter.
- Refrigerated storage for food and drink.
- Trophy cabinets, shelves.
- Bulletin boards.
- Telephone.
- Intercom (if walkie-talkies are not used).
- Television (TV).
- Vending machines.



A nicely appointed staff break room/dining area. Note the amenities provided for staff, such as the salad bar, television, outdoor area, art, and plants.

(Photograph courtesy of Jim Rowenhorst.)

The break room should accommodate about 75 percent of the staff on the largest shift, including jail officers, administrators, and support staff. If the break room is shared with law enforcement staff, their needs must also be met.

If smoking is prohibited in the facility, an outdoor courtyard with a covered area adjacent to the break room would be appropriate and would help keep the officer who smokes in close proximity to where he/she may be needed if an emergency arises. The natural light introduced to the break room through an adjacent courtyard is also beneficial.

Break room location

ISSUE: The break room might be located within the security envelope of the jail.

RESPONSE: The break room/dining area might best be placed within the security envelope of the jail and near the kitchen and thus separate from the other staff areas if:

- Staff meals are provided by the jail kitchen (already within the jail perimeter).
- The break room is not intended for use by law enforcement personnel.
- The space is essentially limited to the break room function and does not serve as a conference room, training area, or staff multipurpose room.
- The sheriff or jail administrator wants to keep staff who are taking a scheduled break within the security envelope so that they can respond quickly to an emergency or problem that might arise. (This may especially be the case in the small jail because the total number of staff available per shift may be quite limited.)

Training/Multipurpose Area

Training is a must for jails of any size. Although larger jails may have extensive training facilities, both inside and outside of the facility, a totally separate training area may be impractical for the smaller jail unless the combined training demands of jail and law enforcement are high enough to justify one. However, this will vary with organizational philosophy and training requirements. One common approach in jails where consolidation is feasible is a combination training/conference/briefing room.

The following functional issues apply to the design of an area for staff training, briefing, and conference rooms.

ISSUE: The training area in a jail can often function as a dual- or multipurpose staff space.

RESPONSE: Design and plan to furnish the space in such a way that its location and furnishings accommodate a wide range of activities. Carefully evaluate the activities

Section 3: Functional Components

that will take place in addition to training. Without good planning, jails, especially smaller jails, often fail to detail the nature and type of staff areas needed and end up with one or more poorly defined and designed rooms.

Staff areas should never be merged with inmate multipurpose space. Aside from time and security conflicts (e.g., inmate access to staff equipment, information, training documents), there may be sufficient legitimate, staff-related activities, even in smaller jails, to justify provision of a separate staff multipurpose area. Such a space could accommodate the following compatible staff activities and functions:

- Conferences and meetings.
- Shift briefings/rollcall.
- Staff training.
- Staff defensive tactics training.
- Staff library and training resource storage.
- Audiovisual storage (LCD projector, laptop computer, video camera, VCR/DVD player, TV, movie screen, easel, and related training supplies).
- Provision for training programs through cable TV or Internet broadcasts.
- Often computer workstations are made available to staff in this or another area that allow staff to access logs, policies and procedures, e-mail, or other work-related information.

ISSUE: Equipment, hardware, and furnishings should match activities and functions.

RESPONSE: The following considerations apply for the staff multipurpose area:

- Size and shape should be compatible with classroom-style instruction.

- Lighting should be adjustable and suitable for both audiovisual presentations and reading.
- Folding tables and folding or stackable chairs enhance flexibility.
- If the room is of sufficient size, a moveable, ceiling-suspended divider adds flexibility for scheduling. An access door should be provided for each side.
- Windows are desirable but are not as great a priority as wall space for shelves, marker boards, tackboards, and storage cabinets.
- Finishes and furnishings should be suitable for activities that entail instruction, reading, writing, listening, concentration, group discussion, and even physical training. An attempt should be made to design, finish, and furnish the space in a way that distinguishes it from the starker



Staff training room.
(Photograph courtesy of Jim Rowenhorst.)

surroundings in other areas of the jail. Otherwise, part of the benefit of having a separate staff multipurpose space will be lost.

- Lockable storage should be available for such equipment as projectors, tape recorders, video cameras, digital video disk players, TVs, and training documents that might include sensitive policies and procedures. If defensive tactics training is included, storage for mats and related equipment is appropriate, as is storage for chairs and tables so that the area may be cleared.

ISSUE: The staff training room might be merged into a space used for other staff functions.

RESPONSE: Since the training room might be used for short periods during the day for regularly scheduled briefings or rollcall, and training might occur irregularly and at different times, it may be wise to consider merging the functions into one multipurpose space. Compatible staff functions include:

- Training.
- Briefing/rollcall.
- Library.
- Staff mailboxes.
- Staff conferences.

Merging physical conditioning with the training/conference functions is not recommended. The physical conditioning area will have fixed equipment that is not easy to move out of the way when the room is used for other activities. The key to any merging of functions is to identify the nature, timing, and frequency involved and to ensure there are no incompatibilities or conflicts.

In very small facilities, merging the break area and training area may be a good use of space. To give some spatial definition to the break area in a multipurpose setting, two ideas might be considered, among others:



- Creating an alcove area for the break room off the main multipurpose space.
- Providing partitions to separate the food preparation and storage area from the training/multipurpose area (exhibit 25-2).

The break area can be made to complement the multipurpose concept by:

- Using stackable chairs for staff dining/breaks.
- Using folding tables that can be moved out of the way.
- Providing an adjacent storage space.

Toilets

ISSUE: There is a need for staff toilet facilities within the security envelope.

RESPONSE: There are many options for providing proper toilet facilities for staff consistent with security and operational goals. Even in the smaller jail, there will undoubtedly be both male and female public

Exhibit 25-2. Use of Folding Partition in Staff Multipurpose Room

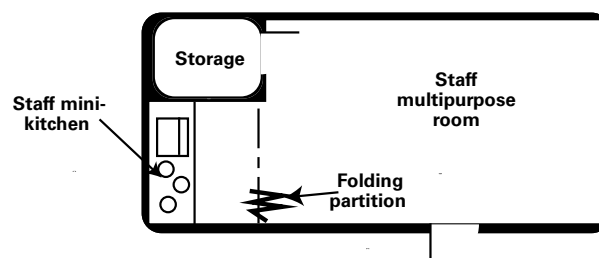

**Section 3:
Functional Components**

toilet facilities in the public reception area and staff toilets in locker/shower areas. If it is intended that these toilets be used by on-duty staff, consideration must be given to the fact that this practice may require staff to move outside the security envelope, creating security problems and considerable inconvenience. In new jails, staff toilet facilities should be planned in various locations inside the security envelope of the jail as a convenience to staff and to facilitate security in the facility.

Staff could use the inmate facilities located in the intake/booking area, although they might object for hygienic reasons. If the jail operates a secure master control or housing control, it will be necessary to locate a single unisex restroom within the control space. However, the use of this restroom by roving staff might violate the perimeter of the control center more than desired by security policy. In direct supervision facilities, there is usually a staff toilet in the housing area that can be used by the officer assigned to the unit and roving officers.

It may be best to provide separate unisex toilet facilities in other areas within the security envelope accessible to staff, such as the intake-release area or staff break room. These facilities should be in easily accessible locations and generally out of view of the inmates.

Space List

Some typical spaces that might be within the staff component include the following:

- Locker/shower area:
 - Male.
 - Female.
- Physical conditioning, including storage.

- Defensive tactics training.
- Break room (possibly including outdoor courtyard).
- Training/multipurpose area, including storage.
- Staff toilets within secure perimeter.
- Parking.

Local codes and Americans with Disabilities Act guidelines regarding accessibility requirements should be consulted when planning these spaces.

Relationships and Components

Exhibit 25-3. Relationships Between Staff Areas and Security Perimeter

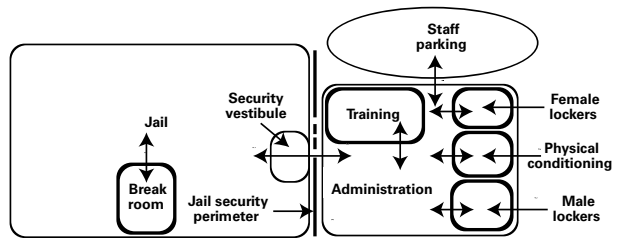
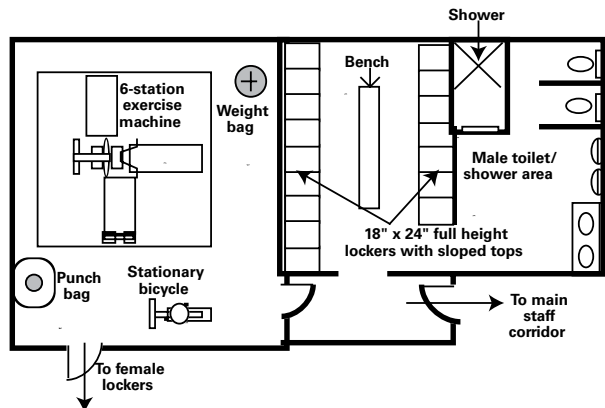

Exhibit 25-4. Physical Conditioning and Locker/ Shower Areas



Chapter 26

Storage Areas

Storage space must be provided in virtually every functional component of a jail. Although less prominent, it is as vital as any other space to attaining efficient and convenient operations. The presence of files, mattresses, and paper goods in the corridors, fire stairs, interview rooms, and staff offices of existing jails is testimony to the fact that storage space has been consistently underestimated in planning and designing new jails.

The storage needs of the various jail functional-architectural components are documented throughout section 3; this chapter addresses miscellaneous storage needs. Additionally, since storage is often an overlooked or underestimated aspect of jail design, this chapter summarizes typical storage needs for all components in a jail of any size and thereby focuses attention on them.

Key Decisions

The following decisions have a fundamental effect on design requirements and should be made when the role of storage is evaluated:

- Is there an opportunity for shared storage space between the jail and sheriff's law enforcement operation?
- What items can be stored together in a general purpose storage room or warehouse, and what items will require separate space?
- Should certain items be stored in one central area, or should they be stored in satellite storage areas served by a central source for greater daily convenience (e.g., linens, toiletries, and/or mattresses distributed from a small storage space at the housing unit but supplied from a larger, centralized storage area)?



Mattresses stored in a hallway.
(Photograph courtesy of Jim Rowenhorst.)

- Will the jail emphasize purchasing at wholesale and, therefore, in large quantities (e.g., food, toiletries, inmate clothing)?

Detail Issues

The following detailed functional-architectural issues should be considered in the development of storage spaces: miscellaneous storage needs and overall facility storage concerns.

Miscellaneous Storage Needs

ISSUE: There are numerous miscellaneous storage needs aside from those associated with specific functional-architectural components.

RESPONSE: Miscellaneous storage needs not yet addressed in other chapters in this section include the following:

- **Central storage/warehouse.** This serves as the primary storage area

Section 3: Functional Components

for a variety of important items, most of which should be identified before design and others after the facility is opened, for example:

- ❑ Bulk supplies (e.g., toilet paper, soaps, detergents, office supplies, forms).
 - ❑ Extra mattresses, pillows, linens, inmate clothing.
 - ❑ Separate, lockable storage area for items sold in the commissary.
 - ❑ Items used in routine maintenance (e.g., air filters, fan belts, oil, car parts, grease guns).
- **Replacement parts.** Every facility should store replacement parts for vital elements of facility operations and security. For example, it would be wise to provide storage for replacement items such as locks, hinges, security glass panels, toilet fixtures, food passage doors, door closers, and door handles as a precaution against damage that compromises the effective operation of the facility. Storage of such parts

would avoid delays in obtaining replacement items, especially special detention items. In larger facilities, a maintenance work area is often designed into the facility. In this case, replacement parts, tools, and items used in routine maintenance would be stored in the maintenance area.

- **Outdoor equipment.** Every facility needs storage space for outdoor equipment unless the county has another department that manages outdoor maintenance for the jail. Equipment that might be stored includes lawn mowers, garden hoses, ladders, yard tractors, snow blowers, shovels, rakes, hoes, and so forth. This need increases if the facility has an inmate gardening program. Outdoor equipment should not be stored in a vehicle sallyport, which has been a common practice in the past. Rather, it should be in a secured space in another location accessible directly from the outside, if possible.
- **Cleaning supplies and equipment.** Every facility needs to maintain cleanliness. This principally involves keeping the floors, furnishings,



Shelving in a laundry area used to store extra inmate clothing and shoes.
(Photograph courtesy of Voorhis Robertson Justice Services.)



Sallyport used for storage creates a hazard for incoming vehicles.
(Photograph courtesy of Jim Rowenhorst.)

and windows clean by the use of mops, buckets, cleaning fluids, cloths, floor buffers, and so forth. Storage space for these items should be provided liberally throughout the facility, preferably in each housing unit. Cleaning equipment is normally stored in a janitor's closet that also includes a janitor's sink or wash tub and a capacity for storing such items as cleaning fluids and dust cloths. Care should be taken to keep toxic, flammable, and caustic materials secured from unauthorized inmate access.

Overall Facility Storage Concerns

This section summarizes basic storage needs in general and some of the characteristics of storage facilities.

Summary list

ISSUE: All storage needs for the entire facility should be identified and associated with their proper functional-architectural component.

RESPONSE: Typical storage needs in a jail encompass master control, intake-release, general and special housing, health care, visiting, indoor and outdoor exercise, inmate programs and services, commissary, food service, laundry, administrative/public areas, staff areas, and miscellaneous storage.

Master control

- Restraint equipment.
- Radios/battery chargers.
- Keys.
- Paper supplies/forms.
- Manuals, directories.
- First-aid kit.

- Self-contained breathing apparatus.
- Fire extinguisher.

Intake-release

- Active records.
- Paper supplies/forms.
- Personal property:
 - Clothing (including suits for court appearances, jackets, hats, boots).
 - Valuables.
 - Money.
 - Bulky items (suitcases, duffel bags, attaché cases).
 - Restraint devices.
- Jail clothing:
 - Shirts/pants or jumpsuits.
 - Undergarments.
 - Footwear.
 - Socks.
 - Jackets.
 - Hats.
 - Gloves.
- Linens/reusables:
 - Blankets.
 - Sheets.
 - Pillowcases.
 - Towels.
 - Washcloths.
- Mattresses.
- Toiletries:
 - Shaving gear.

Section 3: Functional Components

- ❑ Soap.
- ❑ Toothpaste and toothbrushes.
- ❑ Deodorant.
- ❑ Toilet paper.
- Weapons (officer weapon lockers).

General and special housing (including control posts)

- Cleaning supplies.
- Linens.
- Toiletries.
- Clothing.
- Records, manuals.
- Fire extinguishers.
- Self-contained breathing apparatus.
- First-aid kit.
- Board games, cards, other recreation equipment.

Health care

- Supplies.
- Instruments.
- Equipment/carts.
- Records.
- Emergency equipment.
- Medications.
- First-aid kits.
- Medical waste/biohazards.

Visiting

- Visitor log.
- Visitor property (e.g., clothes, purses, attaché cases, hats).

Indoor and outdoor exercise

- Exercise equipment (e.g., balls, nets, poles, weights).

Inmate programs and services

- Records, miscellaneous equipment.
- Stackable and foldable furnishings.
- Paper supplies.
- Books, brochures, magazines, newspapers.
- Religious materials.
- Audiovisual equipment.
- Easel charts, marker boards, markers.
- Recreational equipment (e.g., folding ping-pong tables, balls, paddles).

Commissary

- Commissary goods (dry, refrigerated, frozen).
- Carts.
- Records.
- Writing materials and forms.
- Containers (bags, boxes).

Food service

- Utensils, cutlery.
- Dishware.
- Pots and pans.
- Carts and trays.
- Refrigerated, frozen, and dry foods.
- Garbage, recyclables.
- Records, books.

Laundry

- Detergents, bleaches.
- Carts and bags.

- Records.
- Temporary clothing and linen.
- Miscellaneous cleaning implements.

Administration/public areas

- Records.
- Paper and office supplies.
- Manuals, directories, books.
- Security equipment.
- Audiovisual equipment.
- Staff coats, hats, boots, other items.
- Security keys.

Staff areas

- Clothing, extra uniforms.
- Gym bags.
- Books, manuals, brochures, newsletters.
- Memos, paper records.
- Break area supplies:
 - Coffee.
 - Snacks.
 - Paper cups and plates.
- Audiovisual equipment.

Miscellaneous storage

- Central supplies.
- Outdoor equipment.
- Replacement parts.
- Maintenance equipment.
- Cleaning supplies and equipment.
- Recyclable items (cans, glass, plastic, paper, cardboard).

Security

ISSUE: All storage facilities must be properly secured.

RESPONSE: In general, it is appropriate to prevent random access to all storage areas in the facility by securing them with locked doors. However, it is not necessary to provide heavy security hardware, doors, and construction for many of the facility's storage needs, unless they are located in areas with unsupervised inmate access.

High security is needed principally when the storage facility contains something valuable or potentially dangerous or provides a route of escape to inmates who have access to the storage area. However, the ability to observe the storage area or the access to it may lessen the need for security construction. For example, if a storage area for cleaning fluids and chemicals is directly across from a constantly staffed post, a hollow metal door with an institutional lockset or a low-security detention lockset might be adequate. The gauge of the metal in the door might be selected more on the basis of durability than security.

In assessing security needs with respect to storage, the following types of storage require the highest level of security:

- Officer weaponry.
- Jail keys/proximity cards.
- Medications.
- Cutlery and utensils.
- Personal property, especially money and valuables.
- Medical instruments and equipment.
- Cleaning fluids and detergents.
- Restraint and riot equipment.

Section 3: Functional Components

- Commissary and bond monies.
- Other chemicals and toxic materials.

Special attention should also be paid to the security provided for the following types of storage:

- First-aid kits.
- Toiletries.
- Radios and other communication devices.
- Fire extinguishers.
- Self-contained breathing apparatus.
- Medical records.
- Other records.
- Personal clothing/bulk property.
- Personal articles belonging to visitors.
- Foodstuffs.

Proper security for the preceding storage items can be provided through a combination of approaches:

- Placing certain stored items within enclosed security staff posts.
- Keeping items outside areas accessible to inmates.
- Directly observing access to the storage area(s).
- Employing secure construction around the space, including walls, floors, ceilings, doors, and locks.
- Forbidding inmate access and limiting staff access to sensitive storage areas, such as money, property, weapons, and key storage.

Size

ISSUE: The size of storage space depends on many factors, including institutional policies and procedures.

RESPONSE: The amount of space to provide in any given storage situation depends greatly on the policies and procedures of the facility and the activities that it plans to undertake. Consequently, proper storage space planning must identify these policies, procedures, and activities. Some factors involved in establishing storage space requirements include:

- The range of things that must be stored.
- Size of inventory, which is influenced by ordering and replacement practices.
- Surplus or overflow stocks.
- Storage methods, particularly those that use the full height of storage spaces.
- Capability of storing a wide variety of items in a common area or space.
- System of distribution, which generally varies between a central storage and distribution capability and a smaller central storage area complemented by satellite storage spaces elsewhere in the building.
- Work activities related to storage (e.g., inventory control, ordering, sorting).

Location

ISSUE: Storage areas need to be conveniently located.

RESPONSE: To be used efficiently, storage spaces must be properly located. However, because many storage functions are not necessarily critical to the minute-by-minute operation of the jail, some selectivity in locating storage facilities is important. This is particularly true when the methods of surveillance in the facility and the movement

of inmates from housing to other areas dictate that higher priority be given to locating other functional components. Some criteria to consider when locating storage space include:

- Security of the space and the need to isolate it from access.
- Frequency of use.
- Affiliation of the location and the users involved.

The different priorities in locating storage space are illustrated by contrasting jail clothing storage for the booking area (where routine, 24-hour daily access is required for the efficient flow of inmate arrestees) and central supply storage (which is commonly used only on day shift and typically only by staff as part of a resupply effort).

Mechanical/plumbing concerns

ISSUE: Special mechanical requirements must be recognized in developing storage space.

RESPONSE: Given the nature of some of the items stored in a jail, special mechanical accommodations must be made for the space to function effectively and securely. These include the following:

- Ventilation for storage spaces containing gases (security restraint storage area) or cleaning fluids.

- Humidity controls for storage of paper products, powdered detergents, and similar items.
- Temperature control for areas such as food service.
- Ventilation for storage that generates odors, such as street clothes.
- Chemicals and other toxics.

Space List

Some of the miscellaneous storage spaces that have not been identified as part of the storage requirements for the other functional-architectural components include:

- Central storage/warehouse.
- Mattress storage/cleaning.
- Replacement parts.
- Maintenance equipment/supplies.
- Janitor closets.
- Outdoor equipment.

Local codes and Americans with Disabilities Act guidelines regarding accessibility requirements should be consulted when planning these spaces.

Relationships and Components

Exhibit 26-1. Relationships Between Miscellaneous Storage Areas and Other Jail Components

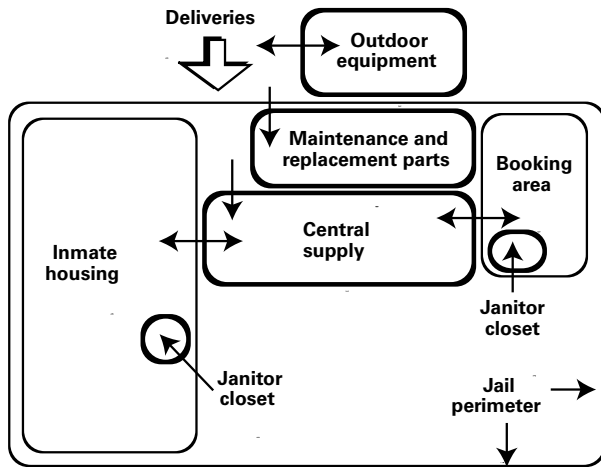
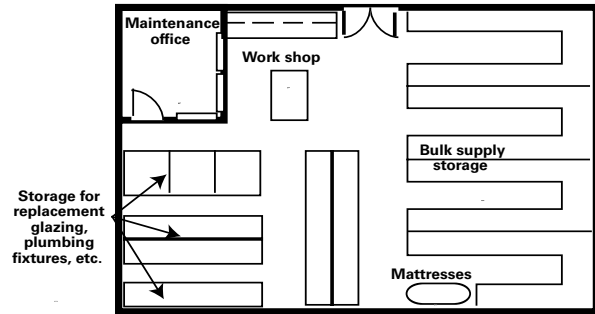

Exhibit 26-2. Central Storage Area



Chapter 27. Single Versus Multiple Occupancy 305

Chapter 28. Renovating Nonsecure Buildings Into Jails311

Chapter 29. Construction and Project Costs..... 317

Chapter 30. Making a Building Work 321

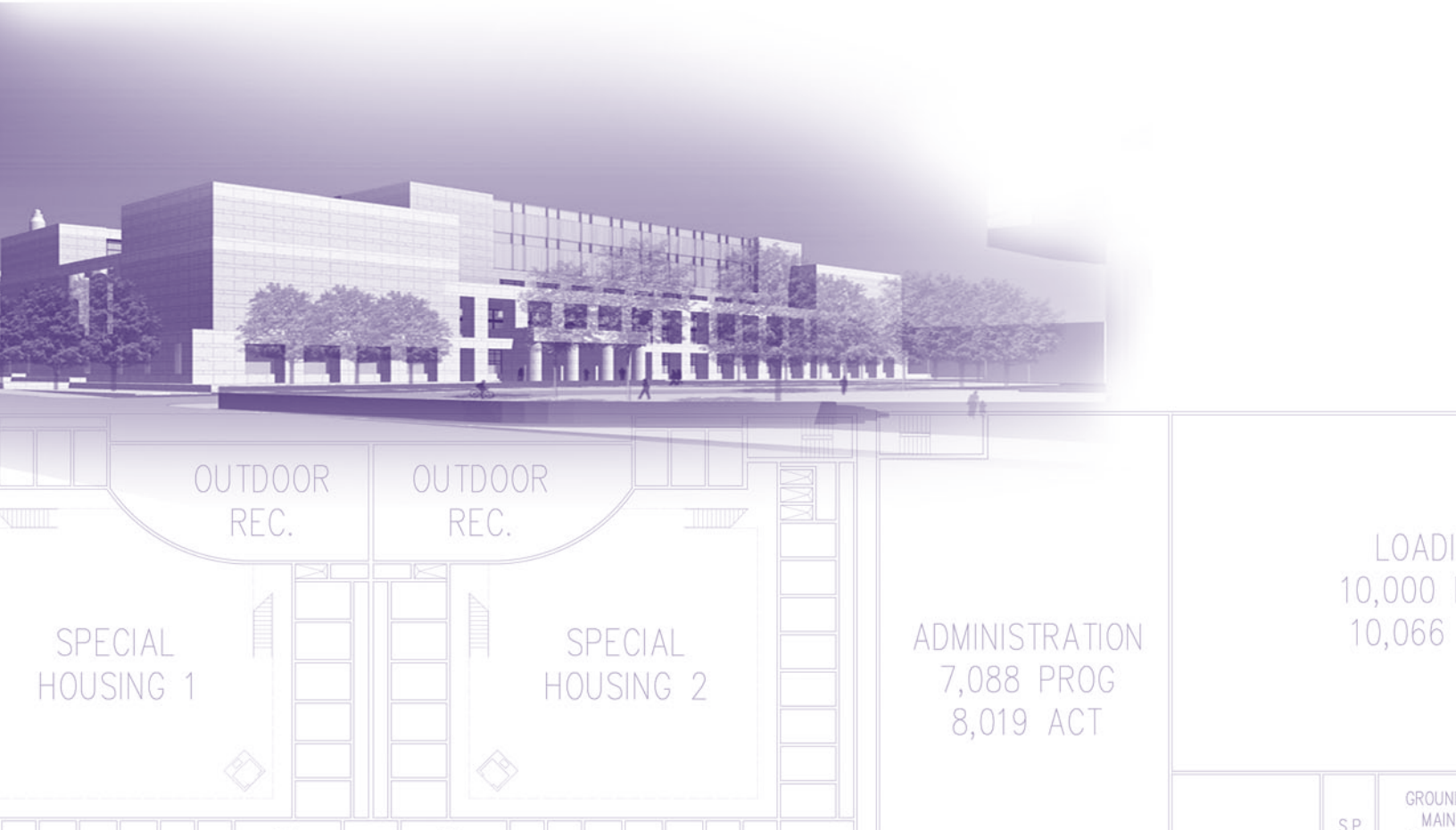

Special Considerations

Four issues deserve special consideration in the development of a jail project.

- Single versus multiple occupancy.
- Renovating nonsecure buildings into jails.
- Construction and project costs.
- Making a building work.

These design and construction issues seem to regularly cause difficulty or controversy in jurisdictions throughout the country, and how they are resolved can substantially affect the outcome or direction of a project. Although space does not permit a full exploration of each issue, these issues are addressed in the hopes that they can be confronted and resolved more expeditiously and knowledgeably by both the planner and the jurisdiction.

Chapter 27

Single Versus Multiple Occupancy

An issue that frequently sparks debate within a community is whether to design inmate cells (sleeping rooms) with one bed (single occupancy) or with two or more beds (multiple occupancy). Local decisions in this regard have a considerable impact on the design of a jail, on project costs, and on the security and management of the jail.

Definitions

Multiple Occupancy

Multiple-occupancy sleeping rooms generally come in three types: cell, “open bay,” and dormitory style. The cell style multiple-occupancy room has historically included beds, a toilet, a sink, and perhaps a desk, stool, and shelf. It does not include such things as a shower or dining table, which are normally provided in adjacent

or nearby dayroom spaces. Cell style multiple-occupancy spaces typically hold two to eight inmates.

Open-bay housing areas are essentially alcoves off a central dayroom and contain 4, 8, or 16 bunk-style beds. The sleeping alcoves contain nothing but bunks, and perhaps storage bins. This type of housing has centralized toilet, sink, and shower areas adjacent to the dayroom.

The dormitory style multiple-occupancy inmate housing unit tends to be more self-contained. Everything needed to serve inmate personal needs is within the single space: beds, toilet, sink, shower, dining tables, storage, telephones, televisions, and so forth (exhibit 27-1). In older dormitory facilities, separate dayroom spaces were not typically included; however, dayrooms are often included in new jails that include



Double-occupancy cell in a direct supervision facility with fixed desk and porcelain fixtures.

(Photograph courtesy of Liebert & Associates.)

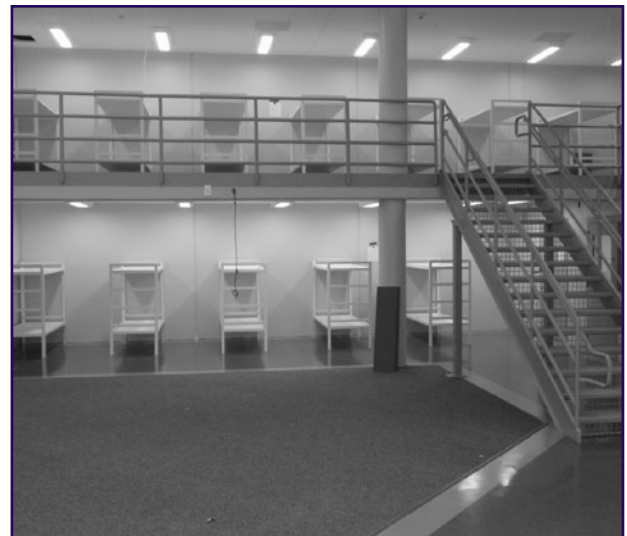

Two-tiered open-bay housing area in a new facility.

(Photograph courtesy of Liebert & Associates.)

Section 4: Special Considerations

Exhibit 27-1. Sample Floorplan of Dormitory-Style Multiple-Occupancy Housing

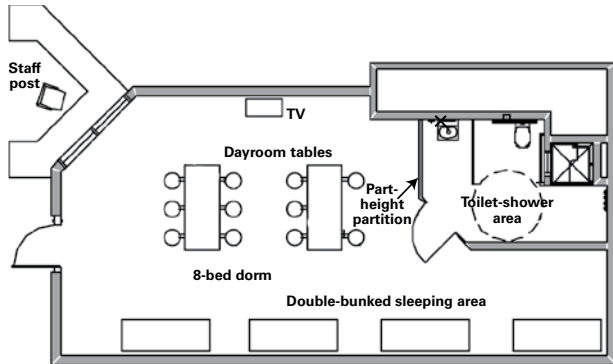

dormitory housing. As few as 8 beds are frequently found in multiple-occupancy dormitories of smaller jails, and as many as 64 beds in those of large jails.

Single Occupancy

A single-occupancy cell normally has a bed, desk, stool, toilet, sink, and shelf at a minimum and shares an adjacent dayroom with other single-occupancy cells (exhibit 27-2).

Standards and Legal Issues

Cases of constitutionality decided in the federal court system have not fully resolved the question of occupancy. Prior to the late 1970s, numerous district courts condemned double celling (two beds per cell). These rulings led to the creation of single-occupancy cells in the affected jurisdictions and led many to conclude that single-occupancy rooms were constitutional and multiple-occupancy rooms were not. However, based on a close reading of the cases, one could not conclude that double celling was in and of itself unconstitutional. Rather, double celling in limited cases has been found unconstitutional given the particular overall conditions of the

Exhibit 27-2. Sample Floorplan of a Single-Occupancy Cell

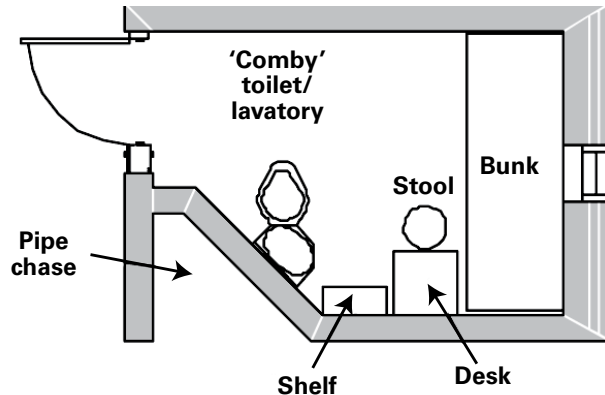

facilities in question: lack of adequate square footage, unsanitary conditions, poor ventilation, inadequate lighting (natural and artificial), lack of privacy, isolation in the cell for extended periods, inadequate exercise opportunities outside the cell, poor surveillance, and many other deficiencies in and out of the cellblock area.

Later, the U.S. Supreme Court ruled on two cases that dealt with the question of multiple occupancy: *Bell v. Wolfish* (1979) and *Rhodes v. Chapman* (1981). In both cases, new facilities were the topic of the suit, and in both cases, the facilities were ruled fundamentally constitutional, having healthful and standards-compliant environments and a variety of amenities in and out of the cellblock areas. The Supreme Court essentially found no constitutional violations on grounds of occupancy alone in those two particular situations. Consequently, thoughts that multiple-occupancy housing was in and of itself unconstitutional began to change.

Since *Bell v. Wolfish* and *Rhodes v. Chapman*, it has become clear that double celling in and of itself is not a constitutional issue unless it can be shown to be the cause of other problems, such as violence related to “failure to protect.”

In 1977, the American Correctional Association (ACA) published its *Manual of Standards for Adult Local Detention Facilities*,¹ which called for the exclusive use of single-occupancy cells. This position was also taken by the U.S. Department of Justice and had been the policy of the federal government in setting criteria for local jail construction projects funded by federal grant moneys. ACA continued to call for single occupancy in the second edition of the *Standards*.

In the third and fourth editions, ACA adopted a more flexible standard that does not specify numbers or percentages of single cells and allows multiple-occupancy cells or dormitories, assuming a series of standards related to square footage are met. ACA emphasized that each inmate have a minimum amount of “unencumbered” floor space in the cell or dormitory. Unencumbered floor space is floor area without an item of furniture or equipment on or above it (exhibit 27-3).

Many states have also placed heavy emphasis on a portion of the jail being single-occupancy cells. The most consistent exception to single

occupancy has been to allow multiple-occupancy dormitories for work release/periodic-sentence inmates or in-house inmate workers (trusties).

The Issue

Central to the single-occupancy/multiple-occupancy issue is the cost of construction versus management and operational concerns. Rapidly increasing jail populations, the high costs of jail construction, and tight local budgets have led many county board and city council leaders to argue for multiple occupancy, while greater security and better management have led many sheriffs, police chiefs, and jail administrators to argue for single occupancy.

Costs

The following benefits of multiple occupancy versus single occupancy do indeed lead to reduced construction costs:

- Fewer cell doors, locks, and hardware sets per bed.
- Fewer toilet and sink fixtures per bed.
- Fewer interior walls.
- Less complicated electrical and mechanical provisions, as well as fewer light fixtures.
- Savings on square footage, including dayroom square footage.

A study done by Farbstein and Goldman, *Housing Pretrial Inmates: The Costs and Benefits of Single Cells, Multiple Cells and Dormitories*, showed that the cost differential between single and multiple occupancy is significant.² The study

Exhibit 27-3. Sample Floorplan of a Single-Occupancy Cell Showing Unencumbered Floorspace

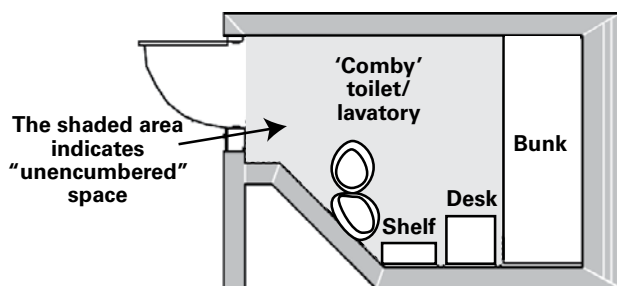

¹ Currently, *Performance-Based Standards for Adult Local Detention Facilities, Fourth Edition* (Alexandria, VA: American Correctional Association, 2004).

² J. Farbstein and M. Goldman, *Housing Pretrial Inmates: The Costs and Benefits of Single Cells, Multiple Cells and Dormitories* (Sacramento, CA: Sacramento County Board of Corrections, 1983). Available at www.ncjrs.gov/App/Publications/abstract.aspx?ID=100262.

found an overall facility construction cost savings of 11–21 percent with various forms of multiple-occupancy housing.

Operational Concerns

Although it is difficult to argue against saving construction costs, jail administrators argue in defense of single-occupancy cells for a variety of reasons. Some jail officials concede that multiple occupancy is acceptable for persons considered low security, such as inmate workers or work-release inmates, even though it results in loss of privacy and vulnerability. However, they argue that single occupancy is a must for inmates with special behavioral, medical, or custody needs, such as:

- Disciplinary detention.
- Medical isolation.
- High security.
- Protective custody.
- Serious mental health issues.
- Juveniles detained in adult facilities.

It is the general population between these extremes for which local jurisdictions must determine whether they want single- or multiple-occupancy housing. Following are the main arguments against multiple occupancy for the general population:

- It greatly reduces the staff's ability to prevent physical or sexual assaults, especially during nighttime lockdown or other times when staffing levels tend to be reduced. The exception would be in direct supervision facilities where staff have a continuous presence.
- It reduces the staff's ability to control inmates during disturbances because the staff cannot fully separate the inmates and achieve a fully secure lockdown until the emergency passes.

- It increases tensions because inmates have no place to which to retreat to ensure personal safety or personal space and no place in which personal property can be completely protected from theft or vandalism.
- It diminishes administrative control because acts of vandalism in the multiple-occupancy cell or dormitory cannot be clearly attributed to one individual.
- It reduces flexibility, in that dramatic shifts in the composition of the jail population may force inmates who require single occupancy into multiple-occupancy spaces.
- It causes inmates to completely forfeit personal privacy because they may openly share toilet fixtures in close quarters and no other area of the facility affords individual privacy.

Single-Occupancy Concerns

Two frequently cited operational concerns about the use of single occupancy are suicide and isolation. The isolation issue is easily resolved, however, with the provision of an adjacent dayroom serving a number of single-occupancy cells. Such a dayroom provides ample opportunity for contact between inmates. Dayrooms are required by the ACA standards and by many state jail standards.

Suicide is a more difficult issue. Many people feel that single-occupancy cells are more conducive to suicide attempts and that the presence of two or more inmates in a multiple-occupancy setting reduces the likelihood of suicide. However, beyond the question of whether inmates should be relied on to prevent suicide by their cellmates, the fact is that suicide has been a problem in jails for years and most jails have, historically, consisted mainly of multiple-occupancy cells or dormitories.

The primary way to control suicide is operational rather than physical:

- Realizing that most attempts occur shortly after intake.
- Using suicide screening at intake to identify suicide risks.
- Providing thorough staff training in recognizing signs and symptoms of suicide risk.
- Providing adequate and frequent staff observation of suicidal inmates.
- Arranging for needed medical and/or mental health services for troubled inmates.
- Increasing supervision and monitoring for those for whom it is determined that self-destructive behavior is likely.

Costs of Multiple Occupancy

On balance, it seems that certain security and management capabilities are compromised to attain the construction cost savings of



Dormitory housing with bunks in the rear of the dayroom/dining area and toilet/shower areas on the right.
(Photograph courtesy of Jim Rowenhorst.)

multiple-occupancy settings. Once compromised, these critical capabilities may be lost for the life of the jail, which could exact a toll on the jail staff and inmates.

Given the increased operational vulnerabilities of multiple-occupancy housing (with the exception of direct supervision facilities), jurisdictions should evaluate whether initial construction cost savings are merely expenses deferred until a later date. Potentially, these savings may at some point be offset by higher medical bills due to more frequent assaults, higher repair costs due to increased damage to jail property, or unanticipated legal costs arising as inmates or their families sue to recover damages as a consequence of injuries received in the jail. Each jurisdiction must weigh the costs of staffing and other issues before committing to multiple-occupancy cells.

Double-Occupancy Single Cells

One idea frequently considered during planning is to build single-occupancy cells for later use as double-occupancy cells. This allows a community to initially commit to single occupancy for standards compliance or better operations, but to accommodate expansion needs quickly and economically at a later date by housing two people in each cell. A variety of problems are inherent to this approach, however:

- Safety and security benefits of single occupancy will be lost.
- Compliance with state or accreditation occupancy standards must be maintained.
- Compliance with cell square footage requirements may be lost. For example, if the single-occupancy cell provides the required square footage for one inmate (per ACA and some state standards), double celling reduces space allocations to half of the minimum square footage per inmate (exhibit 27-4). This same

**Section 4:
Special Considerations**

problem can occur with dayroom space requirements. For example, a dayroom space adequate in square footage to accommodate 50 inmates would now have to accommodate up to 100.

- Designing for future double occupancy may result in a waste of space and money. Referring to the example below, the architect would have to create single-occupancy cells larger

Exhibit 27-4. Square Footage Requirements for Double and Single Cells Based on American Correctional Association Performance-Based Standards for Local Adult Detention Facilities

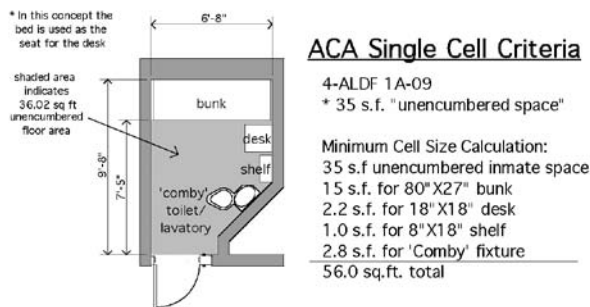

56.94 Sq. Ft. CELL as shown above

* "Unencumbered space" is usable space that is not encumbered by furnishings or fixtures. At least one dimension of the unencumbered space is no less than seven feet.

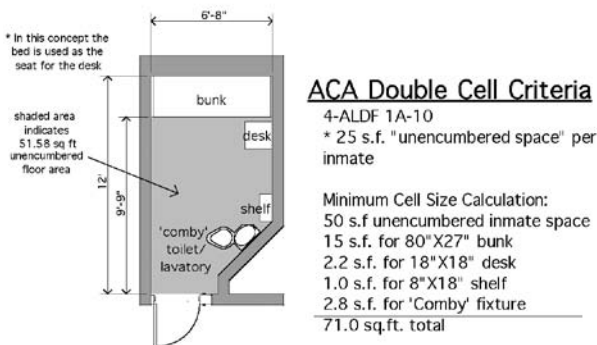

72.50 Sq. Ft. CELL as shown above

* "Unencumbered space" is usable space that is not encumbered by furnishings or fixtures. At least one dimension of the unencumbered space is no less than seven feet.

in size to meet the minimum required square footage per bed after double occupancy. If the need to double cell fails to materialize, space and money will have been wasted.

- Other features of the housing unit and jail will have to be provided in excess (showers and dayroom toilets) or over-designed (ventilation systems, egress elements, plumbing lines) to accommodate possible future double occupancy. This could also result in waste if the double-occupancy option was never exercised.
- Certain classifications are not suitable for double occupancy under any circumstances, thus minimizing the capacity expansion benefits.
- The ratio of staff to inmates may become imbalanced through later double occupancy. For example, a 10-bed area adequately monitored by a master control officer may become too much to monitor if 20 inmates later occupy the area. An adequately supervised 48-bed direct-supervision housing unit may become too much for one officer as a 96-bed unit.

Generally, if sufficient reasons exist to initially adopt a single-occupancy approach to the design of a new jail, those reasons will not likely diminish in the future. If future growth in capacity needs is the reason for creating a double-occupancy option, providing an easy expansion alternative would seem to be the best answer.

Conclusion

Financing a jail is difficult and costly. Therefore, the need to create economical solutions is important. However, each jurisdiction must carefully weigh the pros and cons of single- versus multiple-occupancy housing. Multiple occupancy may not be an effective way to achieve construction cost savings if fundamental security, manageability, operational efficiency, and standards compliance are jeopardized by such an approach.

Source: *Performance-Based Standards for Adult Local Detention Facilities, Fourth Edition* (Alexandria, VA: American Correctional Association, 2004).

Chapter 28

Renovating Nonsecure Buildings Into Jails

When confronted with the need for expensive new jail facilities, county leaders sometimes ask, “Is there an existing facility that could be renovated for less?” This is a natural question in the face of ever higher costs for jail construction and ever increasing demands for bed capacity. It seems especially logical when communities have existing structures available that are of an institutional character, such as hospitals, schools, large retail space, and warehouses. Some communities have even looked at abandoned missile sites and grain silos. Regardless of the buildings available, renovation of an existing structure is a possibility that demands serious consideration.

The quest for renovation possibilities must include an assessment of operational needs. Many existing buildings are eliminated as jail conversion candidates because they do not meet local jail operational requirements and, more specifically, fail to accommodate effective inmate classification, inmate supervision, and staffing efficiency. It is critical, therefore, for a community to clearly establish the character of its future jail operations before, not after, it begins a search for renovation candidates. It is not sufficient to simply find a stout old building and assume suitability for renovation as a jail.

A Common Renovation Example

A hospital is an example of a building that seems to be a natural prospect for renovation, but that potential frequently breaks down under operational analysis. The appeal of hospitals tends to be that they are solidly built, have wings that suggest separate housing areas, and have nursing control stations. Further, they have a series of rooms with toilets and sinks on each wing, which could be envisioned as jail cells. Hospitals

usually have food preparation space and laundry facilities, which can be appealing when looking at renovation possibilities.

The hospital’s basic arrangement, however, can become its greatest weakness. Specifically, most hospitals, including newer ones, are linear in design. They consist of long, narrow wings with rooms on either side of a wide corridor (in architectural terms, a “double-loaded corridor”). The hospital’s linear nature precludes the kinds of views and control required for the direct supervision or indirect surveillance of inmates (exhibit 28-1). Additionally, hospitals are not designed with sufficient common areas that can be used for dayrooms, recreation, or visiting or program space.

The hospital’s potential further diminishes if inmates need to be housed in single-occupancy cells, the minimum size of which is only one-third to one-quarter as big as a normal hospital room. Placing lone inmates in rooms that are 250 to 300 square feet in size is a clear waste of space that also results in low inmate densities per wing and per staff person.

Experience shows that hospitals and similar facilities tend to work best as low-security operations involving intermittently observed dormitory or multiple-occupancy settings. Although the

Exhibit 28-1. Hospital Wing With Poor Views of Rooms and Lack of Dayroom Space

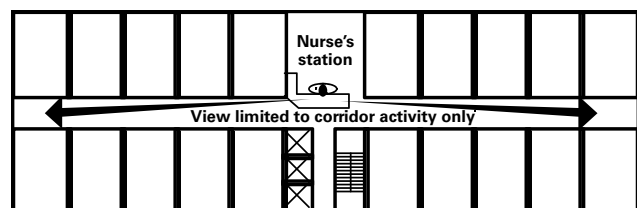

**Section 4:
Special Considerations**

renovation of an existing structure to be used for low-security inmates can be accommodated in larger systems, it is rare for the smaller jail to have enough low-security inmates to justify the acquisition and renovation of a hospital, school, or other large industrial building.

Security Construction

A stout, old building does not necessarily have acceptable security-grade construction and detailing for use as a jail. Therefore, a second hurdle for a renovation candidate to pass is that of security fitness.

Perimeter Issues

Security starts with the building perimeter, or envelope. As outlined in chapter 8, "Security Perimeter," the security envelope is three dimensional, including ceilings, roofs, floors, and walls. Each of these elements, if not secure, must be made secure to prevent escapes and contraband passage.

The thick masonry walls commonly found in older institutional or industrial facilities, which create so much of their appeal, generally have limited escape resistance. Unreinforced masonry, no matter how thick, can be penetrated by removing the mortar that binds the masonry together. Masonry walls in jails are generally heavily reinforced and grouted to foil such efforts (exhibit 28-2). Rectifying wall deficiencies in nonsecure facilities can be very costly, involving options as varied as (1) applying a new barrier, such as steel plate, over the walls, (2) creating fenced perimeters beyond the exterior walls, and (3) creating entirely new perimeter walls within the building.

Windows in older institutional buildings tend to be large in expanse, wood or aluminum framed, and of nonsecurity glass. None of these characteristics is conducive to keeping inmates confined. Therefore, major security revisions must be made while retaining the introduction of natural light required by most jail standards and building

Exhibit 28-2. Comparison of a Typical Hospital Wall With a Typical Jail Wall

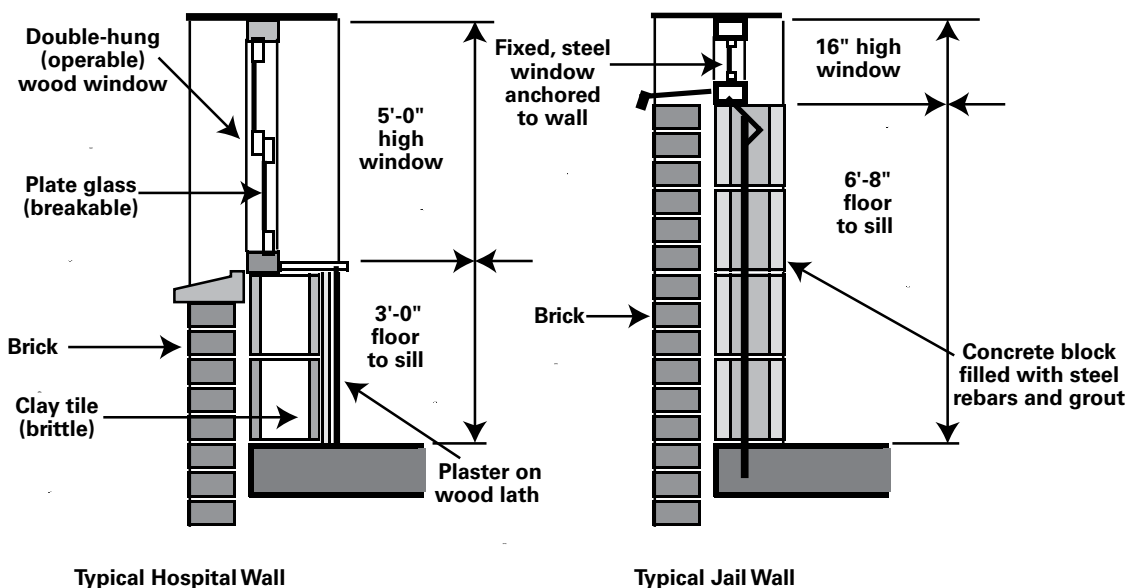

codes. Window modification options include the following:

- Reglazing the entire opening with detention-grade windows and lites (glass).
- Filling substantial portions of the opening and glazing the rest with a security-grade detention window to reduce costs and opening size.
- Applying dense security-mesh screens over the window opening.

The choice between these options may be influenced by another issue, that of minimizing view conflicts between inmates and the public. Such conflicts are a special concern at night when higher indoor light levels enhance views into the jail.

Windows in older institutional facilities may be operable to ensure adequate ventilation. Operable windows are generally not compatible with a jail's need to prevent escapes, communication with the outside, and contraband passage. Therefore, windows must be sealed and mechanical ventilation or air conditioning systems added or enhanced, a potentially costly activity.

Interior Issues

Interior partitions (walls), doors, and locks of institutional facilities tend to be inadequate for jail security needs, thus requiring total replacement and redesign. Light fixtures, switches, outlets, and lighting controls are rarely up to the security and vandal-resistance requirements of a jail and are inappropriately located for a jail. The same is true of radiators, air diffusers, and thermostats. Toilet and sink fixtures, as well as the water lines, drains, and drain covers serving them, are typically unsuited to the rigors of jail use.

These considerations regarding materials, hardware, and equipment are essentially what distinguish jail construction from the construction of other institutional facilities. More importantly, they define the ultimate safety and security of the physical plant and its occupants. These not-so-obvious fine points are frequently missed when a community is initially impressed with the massiveness of an existing institutional facility.

Costs

Many people assume that renovation is less expensive than new construction. This explains renovation's principal appeal and exceeds other virtues such as urban renewal and reuse of existing, otherwise abandoned buildings of value. However, substantial savings are frequently unattainable when converting a building from nonsecurity uses to secure jail uses. Further, the cost saving issue is complicated by two other considerations: long-term operational costs and acquisition costs.

Construction Costs

If a building appears substantially constructed, the assumption is that the cost of any internal modifications is offset by the money saved by avoiding exterior construction. However, when the costs of a jail are broken down, it becomes clear that only a fraction of the total cost of building is spent on the outer shell. Exhibit 28-3 shows a breakdown of jail costs by different components of construction, as reported in RSMean's *Square Foot Costs*.¹ Working from that list, the portions of the building listed in exhibit 28-4 represent the shell, that is, the walls, roof, floor, foundation, and key structural elements involved in their creation.

¹ *Square Foot Costs, 27th Annual Edition, 2006* (Kingston, MA: RSMean's Construction Publishers & Consultants, 2006).

**Section 4:
Special Considerations**

Exhibit 28-3. Jail Costs by Construction Component

Construction Component	Percent
Substructure	1.7
Superstructure	13.0
Exterior closure	12.0
Roofing	1.0
Interior construction	6.5
Conveying (elevators, etc.)	1.9
Plumbing	17.7
HVAC	8.5
Fire protection	0.2
Electrical system	8.1
Equipment and furnishings	29.4
All construction components	100.0

Exhibit 28-4. Jail Shell Costs

Shell Costs	Percent
Substructure	1.7
Superstructure	13.0
Exterior closure	12.0
Roofing	1.0
Total shell costs	27.7

Although the shell looks impressive and gives the appearance of great value, it represents only about 28 percent of the total construction cost of a jail. Therefore, about three-fourths of a jail’s construction cost is in the interior elements.

Saving one-fourth of the cost of construction is certainly attractive, but renovation entails additional costs. A major cost is potentially that of upgrading the shell to security status, which may involve reinforcing walls, building walls within the walls, adding security windows (sometimes by cutting openings through solid walls), and securing the ceiling/roof assemblies. If the particular building being examined has walls, doors, ceilings, and floor finishes that must be removed to make way for the jail design, a demolition cost is added to the cost projection.

Reconfiguring the floor plan to meet jail needs can require all new walls, ceilings, and floor finishes. It can involve replacing existing conduits, wiring, and power supplies as well as replacing and relocating lighting fixtures. Reconfiguring can also require altering the location of supply and return air ducts and openings. Redoing plumbing systems and penetrating existing flooring for new water supply and drain lines can be very costly. Nonsecurity suspended ceilings, such as lay-in ceiling tiles and drywall ceilings, may need complete replacement. New concrete block cell walls can add excessive load to the floor, thus requiring additional structural support. Depending on the building, making all of these changes can be a very expensive proposition. These sorts of cost factors can quickly erode the money saved on the shell, thus leading to costs comparable to those of new construction.

Even if conversion is feasible and renovation would save 10–20 percent of the cost of new construction, the jurisdiction is once again advised

to consider operational issues before committing to the renovation project. Given that a building designed for a different function is being converted, the renovation layout is frequently not as effective or efficient as a new design and may have inevitable, unacceptable functional compromises. Other planning concerns, such as the need for expansion, sufficient parking, and public access, may also be compromised.

Operational Costs

Operational costs, particularly those of staffing, are actually the biggest part of a jail's economics. Over the long run, the costs of staffing and operating a jail will far exceed the costs of construction and project financing. If the price of cheaper construction is the addition of one or two more 24-hour-a-day, 7-day-a-week posts, the economic impact on a jail can be devastating. The cost analysis in exhibit 28-5 demonstrates the differences over a 20-year life cycle between a new 125-bed jail and a renovated facility of equal capacity. The essential differences are that renovation costs are assumed to be 20 percent less than new construction and the staffing for the renovated facility is greater by one officer per shift. An average interest rate of 6 percent and an inflation rate of 4 percent are used.

Acquisition Costs

A key factor in assessing project costs is the acquisition cost of the site and building being considered for renovation. The purchase price of the facility could be greater than any potential savings over new construction. Also, if private property is purchased, the cost calculation must take into account tax receipts that will be lost once the property is removed from the tax rolls.

Conclusion

Local officials should by all means examine renovation options before committing to new construction. Construction cost savings may be there to find within the context of creating secure facilities that meet local needs.

However, experience shows that many renovation options either fail to offer the savings initially expected or offer measurable savings at the cost of functionality, safety, or staff efficiency. Before a jurisdiction enters into public or private commitments, it should temper its enthusiasm for renovation options with a reasoned analysis of a building's ability to meet preestablished goals for inmate classification, surveillance/supervision, safety/security, staffing efficiency, and true convertibility.

**Section 4:
Special Considerations**

Exhibit 28-5. Cost Analysis of Renovation That Requires Addition of One Staff Post

EXAMPLE: SAVING CONSTRUCTION COSTS BUT ADDING ONE STAFF POST

STAFFING:

	Number of of BEDS	TOTAL STAFFING			Sub-Total	Shift Relief Factor *	TOTAL STAFF
		Shift 1	Shift 2	Shift 3			
RENOVATION	125	8	8	6	22	1.67	36.7
NEW	125	7	7	5	19	1.67	31.7

* "SHIFT RELIEF FACTOR" ACCOUNTS FOR IMPACT OF WEEKENDS, VACATION, SICK LEAVE, TRAINING TIME, ETC. ON STAFFING A 24-HR/DAY, 7 DAY/WEEK POST.

COST ANALYSIS:

Project Financing Rate =	6.00%	Inflation Factor =	1.04
Years of Financing =	15	Years until Opening =	2

15 YEAR COSTS:

PROJECT TYPE	CONSTRUCTION COSTS				STAFFING COSTS				TOTAL 15 YR. CONSTRUCTION & STAFFING COSTS
	Estimated Construction Cost (2006 Dollars)	Average Annual Payment	Total Financed Construction Cost	Total # of Staff	2006 Officer Salary	Fringe Benefit Factor	Total First Year Staff Cost (1996 dollars)	15 Year Total Staff Cost w/Annual Inflation; 2 yrs until opening	
RENOVATION	\$8,000,000	\$823,702	\$12,355,532**	36.7	\$35,000	1.35	\$1,735,965	\$37,596,685	\$49,952,216
NEW	\$10,000,000	\$1,029,628	\$15,444,415	31.7	\$35,000	1.35	\$1,499,243	\$32,469,864	\$47,914,279
Difference w/Renovation	-\$2,000,000	-\$205,926	-\$3,088,883	+5.0	\$0		+\$236,723	+\$5,126,820	+\$2,037,938

** Renovation saves 20%

COMPARISON CHART:

Total 15 year life cycle costs

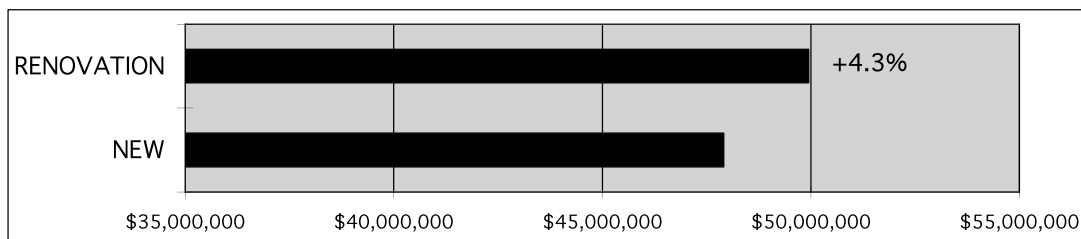

Source: Kimme & Associates, Inc., 2006.

Chapter 29

Construction and Project Costs

Although jail construction costs are significant, they do not represent the total per-bed cost paid by a jurisdiction to complete its project. Additional costs significantly increase the expense of the jail. When these costs are added to construction costs, one arrives at the actual **project cost**.

The project cost represents the true cost of building a jail and is not clearly understood by many jurisdictions. Failing to understand the difference between the project cost and construction costs has caused jurisdictions to plan inadequately for project funding or for referendums requesting funding. This, in turn, has led to underfinanced projects that provide less capacity than required, less support and program space than needed, and/or a building with less quality and durability than desired. It has also led to embarrassment when the public has seen that their local officials did not understand the costs involved in the jail project. This chapter clarifies the differences between construction and project costs.

Construction Costs

Construction costs are those costs that relate specifically and exclusively to the construction of the building. They typically include costs for:

- Site preparation.
- All materials required for construction.
- All labor required to assemble the building materials.
- All overhead and profit of the contractor(s).
- All equipment and furnishings that are physically attached (fixed) to the building.

- Basic site improvements, such as landscaping and on-grade parking and sidewalks associated with the building.
- Signage.
- General conditions, such as warranties, permits, insurance, testing, shop drawings, and so forth.

Project Cost

Even though construction costs represent the major part of a jail's cost, many other costs must be incurred to actually build the jail. These "**other costs**," when combined with construction costs, give the total project cost.

The other costs involved in producing a project can be quite significant. As a rule of thumb, it is wise to plan initially on adding 20–30 percent to the construction costs of the building (exhibit 29-1). That is, if the jail is expected to cost \$10 million to construct, it would be wise initially to add another \$2–\$3 million to estimate the true project cost. A \$10 million construction cost could easily result in a \$13 million project cost.

Exhibit 29-1. Total Project Cost

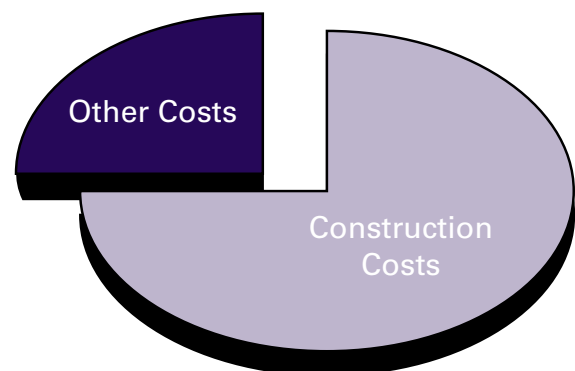

Section 4: Special Considerations

The ratio of project cost to construction costs will vary considerably from jurisdiction to jurisdiction because many variables are involved. It is critical, however, for a jurisdiction to conduct all of its financial planning, even from the earliest phases of the effort, with an appreciation of all costs involved with the project.

Project Cost Factors

The most significant and typical cost factors that add to basic construction costs to create a project cost follow.

- **Site acquisition.** This covers the cost of any land and buildings needed to create the jail site.
- **Demolition.** If the acquired site has existing buildings or features such as pavement or retaining walls, the cost of demolishing these structures and disposing of the waste in preparation for future construction must be taken into account.
- **Utilities.** Costs are associated with providing utilities to a site (particularly a remote site) or relocating existing utilities (e.g., gas lines, power lines) that would otherwise interfere with construction.
- **Professional fees.** These are the fees for the architects and engineers who will design the building and develop all of the structural, mechanical, electrical, and civil engineering systems for the building and the site. Fees will vary depending on the size and complexity of the building and whether it is new construction, renovation, and/or an addition. Professional fees also include those for specialists such as food service consultants, interior designers, and construction managers. Many jurisdictions will retain the services of a jail planner early in the facility development process to conduct a needs assessment and feasibility study prior to engaging a design firm(s).
- **Reimbursables.** Various expenses are incurred by professionals during the course of the project and are generally billed back to the owner as a reimbursable expense. Typical reimbursables for an architect, for example, include the costs of travel, report printing, courier services, and construction document reproduction.
- **Furnishings and equipment.** All of the desks, chairs, file cabinets, copy machines, computers, kitchen and laundry equipment, inmate furniture, and other unfixed items that must be purchased for the operation of a building incur additional expenses. Also included in this cost might be such things as potted plants, window coverings, and other unattached office decorations.
- **Site survey.** Before design can begin, a complete survey of the site must be completed. This survey will establish the location of all buildings, the contours of the site, the location of all utilities, and any easements and setbacks.
- **Special testing.** A variety of special tests not typically included in the construction contract will be made before and during construction, such as tests of the soil conditions and selected materials.
- **Legal fees.** A variety of legal fees might be paid during the project, for example, fees for condemning and acquiring properties. Legal fees may be incurred in developing clear title to land, requesting variances, obtaining zoning changes, settling disputes, and negotiating contracts.
- **Project manager.** Some jurisdictions think it is wise to hire their own project manager. This representative serves as a liaison between the county, the architect, and the contractors. The project manager helps ensure that the project is proceeding in accordance with contractual obligations required by the county. Such a person may also keep a record of design

and construction progress for the county as insurance against failures to meet contract demands.

- **Selling bonds.** If bonds must be sold to finance a project, a fee is generally paid to the firm or individual arranging for the sale.
- **Transition.** To prepare for the transition into the new jail, jurisdictions are well advised to add funding for a transition team made up of existing staff members and, perhaps, a consultant, to focus on the significant amount of work to be done before opening the new building: writing policy, procedures, and staff post orders; establishing a hiring and training schedule; and so forth. More on this important subject can be found in chapter 30.
- **Moving.** Professional movers are sometimes retained to move furniture and equipment from the old building to the new.
- **Telephone and radio communications equipment.** Telephone and radio communications equipment is frequently purchased from a vendor or provider outside of the normal construction contract. For law enforcement portions of a jail, the cost of the E-911 radio equipment and computer-aided dispatch systems are generally outside the construction budget.

Example

Exhibit 29-2 shows an example of a hypothetical project budget based on a \$10 million construction cost and the typical cost factors outlined above. In this example, the cost factors other than construction costs are equal to about 22.6 percent of the cost of construction and represent 18.4 percent of the total project cost. These costs can vary considerably from project to project and may include other factors. This example is provided only to enhance the reader’s understanding of the magnitude of the project cost.

Exhibit 29-2. Hypothetical Project Budget

Cost factor	Cost (dollars)
Construction costs	\$10,000,000
Other cost factors	
Site acquisition	\$500,000
Demolition and disposal	\$50,000
Utility relocation	\$50,000
Professional fees	\$700,000
Reimbursables	\$60,000
Furnishings and equipment	\$400,000
Site survey	\$20,000
Testing	\$20,000
Legal fees	\$40,000
Project manager	\$100,000
Transition	\$100,000
Moving	\$20,000
Telephone equipment	\$200,000
Total other costs	\$2,260,000
Total project cost	\$12,260,000

Conclusion

In planning the financial aspects of a proposed project, it is important to understand all operational and construction-related costs to be incurred. Only then can a jurisdiction make informed decisions about the size and nature of the project to be developed and adequately prepare for the expenses to come and the revenues needed to cover them.

Chapter 30

Making a Building Work

A common mistake made by many local government officials is to think that their role in the development of a new jail ends with the completion of the architectural phase of the project.

Others mistakenly feel that their role is ended before construction documents are complete because construction demands are such that the client frequently feels there is little he or she can contribute or has been convinced that the architect or contractor will simply turn over the keys when the building is complete. The jurisdiction must remember that a jail facility's security and overall success depend largely on staff and management. In fact, attention to operational and transitional issues at this point will yield major benefits later. Failure to plan for the opening of a new facility has led to a number of embarrassing problems:

- Delays in the opening of new facilities when it was discovered that the recruitment, selection, training, and funding of new staff had been overlooked.
- Multiple system failures in the newly occupied jail due to lack of testing of equipment prior to moving the inmates into the new facility.
- Discovery upon opening that the staff were not sufficiently trained in the operation of the more complex equipment and systems found in their modern, high-technology facility. In one instance, inmates were able to simply walk out the front door of a new jail because staff did not fully understand the door status indicator system.
- Considerable damage to new facilities because they were seriously understaffed or staff were

improperly trained—or not trained—in managing the inmate population. This can be a serious problem in direct supervision facilities when staff members are not adequately trained in inmate management.

- Failure to implement the inmate classification system or planned services and programs intended to alleviate boredom and manage behavior because these things simply were not given priority in the transition process. As one sheriff put it, “Once you open the door, all hell breaks loose.”
- Rapid overcrowding for reasons other than being built too small. For example, the size of numerous new jails has been based on assumptions about continuation or implementation of population-reducing alternatives to incarceration that either were not implemented after the new jail opened or were subsequently discontinued.
- Considerable disruption, unrest, and verbal and physical confrontations among inmates in the housing units of newly opened facilities because staff had little knowledge of a classification system that was intended to separate the violent from the nonviolent and the “prey” from the “predators.”

These are all examples of facilities that did not “work” well. They were not all necessarily facilities that were poorly planned, designed, or constructed. Rather, they were facilities where there was inadequate preparation for opening or where key planning assumptions were never implemented or staffing and budget commitments fell short.

Detailed information about the transition process can be found in the *Resource Manual for*

Section 4: Special Considerations

Transition to a New Jail published by the National Institute of Corrections;¹ nevertheless, an introduction to transition concepts is an important part of this document. The purpose of this chapter is to alert those involved in new jail design projects to postdesign activities that must be pursued if the architecture of the new jail is to solve the problems they had hoped it would. It is critical to remember that buildings only *contain behavior* and that it is incumbent upon management and line staff to *control the behavior* of those confined.

Assuming that good procedural operations, adequate staffing, and effective staff training are vital to the success of a jail design, it is strongly recommended that local officials and jail staff undertake a series of critical tasks in preparing for the opening of a new jail. These tasks are essential to the success of a new jail in terms of minimizing initial and long-term operating problems and increasing the satisfaction of the owner, the user, and the public. Without executing these tasks, a city or county will not be prepared to operate its new jail because the jail will probably be vastly different in size, technology, and complexity from the one it replaced. The following tasks are essential to making a smooth transition from old to new facilities: construction monitoring, policy and procedure development, final staffing plan and staff post orders, staff recruitment and selection, staff training, and move logistics.

Construction Monitoring

The transition team is often tasked with monitoring the construction process, not only to become familiar with the new building, but to watch for



Transition team conducting an inspection of their new facility.
(Photograph courtesy of Rocket Media.)

problems in the process. Because the transition team is made up of facility staff, it can prove to be a significant resource in identifying potential problems, such as gaps or improperly installed fixtures that result in hiding places for contraband; equipment, fixtures, or construction that do not meet specifications; and shoddy workmanship.

Policy and Procedure Development

A comprehensive set of written operational policies and procedures is vital to operating a jail that avoids incurring unnecessary liability risks. Well-researched and drafted policies and procedures tailored to a particular facility serve the jail administration in many ways. Primarily, they provide an essential training tool that ensures consistency of performance among all jail officers and other staff, provides guidance for staff when

¹ Gail Elias and John Milosovich, *Resource Manual for Transition to a New Jail* (Washington, DC: U.S. Department of Justice, National Institute of Corrections, 2005), www.nicic.gov/Library/020159, accessed February 26, 2010.

administrative personnel are not immediately on the scene in an emergency, and provides protection for the county against liability when individual acts can be shown to be outside of the prescribed practices dictated by the policy and procedures manual.

No facility, particularly no new one, should operate without a well-researched and knowledgeably prepared set of written policies and procedures that are developed specifically for the facility and are compliant with current case law, professional practices, local statutes, and state and professional standards. The policy and procedure development process requires heavy involvement by local jail staff. The process of preparing a policy and procedures manual includes the following tasks:

- Outline the issues and topics to be covered.
- Review previous manuals or manuals from other facilities for relevancy and new ideas (errors, omissions, deletions, or additions).
- Research and document applicable case law, state statutes and standards, and recommended professional standards.
- Hold discussions during which key policy decisions are made.
- Tailor all policies and procedures to the specific design solution proposed and the inmate management plan.
- Draft specific scenarios for all of the procedures to be implemented in the new facility.
- Draft the initial policy and procedures manual.
- “Field test” the draft policies and procedures by walking through them on facility models or plans or in the facility itself.

- Review, comment, and modify until the final document is complete.
- Train all staff.
- Develop a way to make modifications to procedures once training has been completed and the facility occupied.

Final Staffing Plan and Staff Post Orders

A final staffing plan for the new facility that is consistent with the final facility design and the revised policies and procedures must be prepared. This includes documenting staff needs by function, number, and shift, including consideration of the impact of weekends, holidays, sick leave, training leave, absenteeism, and other such factors that affect the need for post coverage.²

Post orders detailing precise responsibilities and tasks for each post and position indicated in the final jail staffing plan and the written policies and procedures must be prepared and implemented in the same manner as operational policies and procedures. Whereas the policies and procedures provide staff direction for *what* is to be done, *why* it is to be done, and *how* it will be done, post orders detail *which* tasks are to be done, *when* they are to be done, and *who* will do them.

Staff Recruitment and Selection

Staff recruitment and selection have evolved from a very simple process to one that often involves the administration of a variety of psychological screening and aptitude measurement instruments and oral interviews. Haphazard recruitment and

² See Dennis Liebert and Rod Miller, *Staffing Analysis Workbook for Jails, Second Edition* (Washington, DC: U.S. Department of Justice, National Institute of Corrections, 2001), www.nicic.gov/Library/016827, accessed February 26, 2010.

Section 4: Special Considerations

selection can seriously jeopardize the operation of a new jail and expose the local government to tremendous liability. Jurisdictions should execute this process according to a plan consistent with formal personnel practices and state/federal laws governing employment.

Too many jurisdictions do not devote sufficient time to recruitment and selection. New staff should be hired well in advance of the facility's scheduled opening so that they can participate in mandatory state (academy) training programs and local training specific to the new facility.

Staff Training

New and current officers need training in the operation and philosophy of the new jail. Such training should focus on current case law, techniques of managing inmates, and, most importantly, on the application of the new policies and procedures that have been written and must now be implemented.

Training jail officers in policies and procedures for advanced inmate supervision and management



Transition team meeting.
(Photograph courtesy of Rocket Media.)

techniques and for the operation of the new electronic equipment and hardware in the jail is critical. Such training should be in addition to any mandatory basic training required by the state. The training should also emphasize practical exercises, such as conducting emergency facility evacuation drills and responding to “officer down” situations.

Testing should be administered to ensure adequate understanding and performance of just how the new facility equipment and physical plant are intended to operate and to identify areas where staff have particular questions or problems.

Move Logistics

Each jurisdiction must prepare a detailed plan for making the actual move to the new jail and the sequencing steps involved. Move logistics include considerations such as the following:

- The means of transporting inmates to the new facility.
- When to begin moving inmates and equipment.
- How to move inmates and equipment in such a way that both staff and inmates can move gradually and smoothly while closing down the old jail.
- Arrangements for enhanced security during transport.
- Plans for staffing two or more facilities during the inmate transfer.
- Numerous other related matters.

The following tasks must be considered when developing a move logistics plan:

- Preparing and delivering training programs for new staff, existing staff, supervisory staff, and so forth.
- Scheduling and conducting public tours.
- Assisting in interviewing potential staff.
- Testing equipment and observing its installation for training of staff on its operation.
- Preparing the overall Transition Master Plan and schedules.
- Orienting other law enforcement agencies, vendors, and other facility users for interaction at the new facility.
- Finalizing and directing the actual move.
- Preparing orientation material for inmates who will be transferred to the new facility.
- Conducting facility shakedowns and “walking through” all operational scenarios.
- Coordinating with maintenance staff on the operation of mechanical and electrical systems.
- Developing emergency plans for inmate evacuations that include inmate retention, emergency staff provisions, and fire drills for new staff.
- Documenting that all new furniture, equipment, and forms have been ordered and installed.

New facility mechanical and electrical systems are typically far more complex than those found in other existing county buildings and the old jail. It is of critical importance that existing or additional county maintenance personnel who will be assigned to the new facility have an opportunity to monitor the onsite installation of mechanical, plumbing, and electrical systems. It is also important to involve local facility maintenance staff in all postdesign activities involved in the construction phase.

Summary

Making the new building work will require team work, good communication, a cooperative spirit, and full commitment from all those who were involved in preactivation (planners, designers, contractors, and transition staff) as well as those involved in the activation and operation of the facility (the funding authority, management and line staff, support staff, maintenance personnel, volunteers, and the community) if the facility is to realize its full potential and serve the community as intended. Although this is not an easy proposition, failure is not an option.