

3.4 THOR-LX / HIIIr Calibration

A series of static and dynamic tests are performed on each THOR-LX / HIIIr assembly prior to shipment from the manufacturer. Static testing is performed on many of the materials and parts prior to assembly to ensure consistency and repeatability. Calibration procedures for these tests are described in the THOR-LX / HIIIr Calibration Manual - available from the manufacturer as a separate publication.

3.4.1 Ankle Rotary Potentiometer - Zeroing Procedure

The rotation of the THOR-LX / HIIIr ankle joint is measured about three principal axes using precision rotary potentiometers. The calibration of these potentiometers is carried out in two stages - the primary calibration is performed prior to installation in the ankle unit - a secondary calibration is performed once the ankle unit is assembled. The primary potentiometer calibration is carried out on a fixture which rotates the potentiometer to 13 known angular positions - the output voltage for each position is recorded and a numerical regression is performed to determine the calibration value in degrees per volt (for a 10V excitation). See drawing T1AKM000 for additional details of the primary calibration. The second stage of the potentiometer calibration takes place after the unit is installed into the appropriate ankle joint. This calibration is used to determine the voltage output of the potentiometer when the ankle is locked in a known calibration position. This value is used to determine the angular position of the foot relative to the tibia. This value is critical to the accurate evaluation of the ankle performance, since the corridors require a very precise measurement of the foot rotation. All calibration tests are conducted with an excitation voltage of 10.00 +/- .0.05 V.

The calibration position used for this second stage of calibration is with the foot perpendicular to the tibia tube in all three principal rotation directions. The various calibration positions are indicated in **Figure #3.46**.

Equipment Needed:

- " THOR-LX / HIIIr Unit
 - " Voltmeter and Power Supply
 - " THOR-LX / HIIIr Ankle Rotary Pot Calibration Fixture (T1CEM420 - Available separately from the manufacturer)
 - " Mounting Bolts and Hardware (See T1LXC000)
1. Remove the tibia skin and tibia guard from the THOR-LX / HIIIr assembly.
 2. Remove the foot skin and unbolt the composite plate (with the Achilles mounting post attached) from the base of the ankle unit..
 3. Refer to drawing T1LXC000 for a complete drawing showing the proper attachment of the calibration fixture. Attach the bottom of the calibration fixture to the lower ankle base using four 0.312" diameter shoulder bolts. Attach the top of the calibration fixture using

two shoulder bolts and two 1/4-28 x 3/4" SHCS. See **Figure 3.47**.

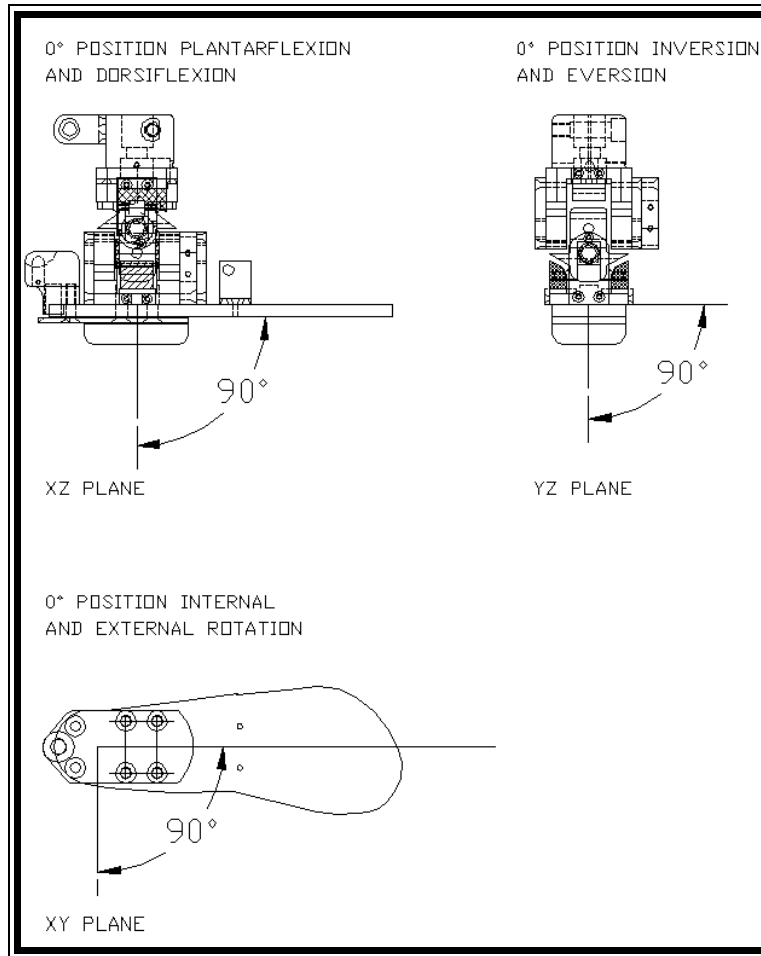

Figure #3.46 - Calibration Positions for Ankle Joint

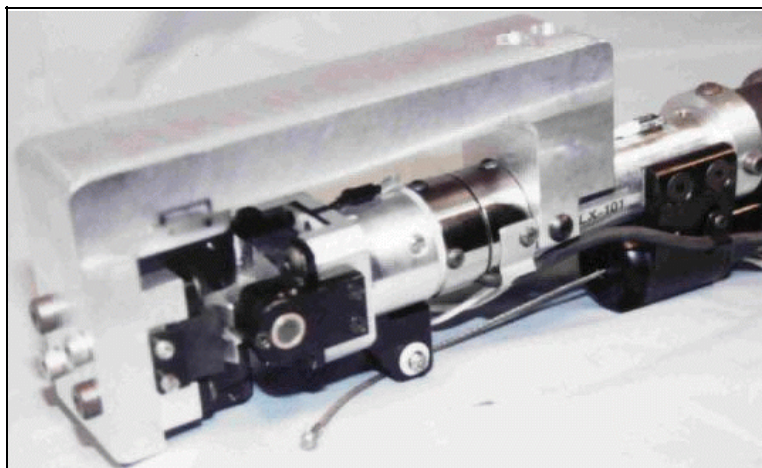

Figure #3.47 - Calibration Fixture Orientation

4. Record the potentiometer voltage output at this position - this is the zero position for all rotation directions.

NOTE:

The manufacturer will provide the offset values of the potentiometers in the different directions (for excitation of 10V). These offset values are the potentiometer voltages when the foot is kept perpendicular to the tibia. It has been noted experimentally that the static response is sensitive to the offset values, such that if there was a change of .06 V or more, then there would be change in the response curve. During development testing, the offset value was found to be stable during the course of the testing, but it may be worthwhile to make a measurement of it, if a significant number of tests are being conducted, in order to ensure that there is no drift. Drift would normally indicate that there is some slip occurring between the D-shaft and the corresponding hole in the potentiometer. Similarly, when the potentiometer rotation direction is changed (to change between dorsiflexion and plantarflexion, or between inversion and eversion), the offset value should not change by more than 0.01 - 0.02 V. Larger offset values would indicate a backlash problem between the potentiometer and the shaft. A drop of removable loctite #242 will usually cure any problems with backlash or slip. If the problem persists, the potentiometer should be replaced with a new unit.

3.5 Inspection and Repairs

After a test series has been performed, there are several inspections which may be made to ensure that the dummy integrity has remained intact. Good engineering judgement should be used to determine the frequency of these inspections, however the manufacturer recommends a thorough inspection after every twenty tests. The frequency of the inspections should increase if the tests are particularly severe or unusual data signals are being recorded. These inspections include both electrical and mechanical inspections. These inspections are most easily carried out during a disassembly of the dummy. The disassembly of the THOR-LX / HIIIr components can be performed by simply reversing the procedure used during the assembly.

3.5.1 Electrical Inspections (Instrumentation Check)

This inspection should begin with the visual and tactile inspection of all of the instrument wires from the neck instrumentation. The wires should be inspected for nicks, cuts, pinch points, and damaged electrical connections which would prevent the signals from being transferred properly to the data acquisition system. The instrument wires should be checked to insure that they are properly strain relieved. A more detailed check on the individual instruments will be covered in Section 4 - Instrumentation.

3.5.2 Mechanical Inspection

Several components in the THOR-LX / HIIIr assembly will need a visual inspection to

determine if they are still functioning properly. This mechanical inspection should also involve a quick check for any loose bolts in the main assembly. Each area of mechanical inspection will be covered in detail below. Please contact the manufacturer regarding questions about parts which fail the mechanical inspection.

Achilles Tendon Cable: The following check should be performed when inspecting for post-test damage:

Check for kinks and broken strands

Ankle Soft Stops: The following check should be performed when inspecting for post-test damage:

Check for permanent compression, nicks or tears

Ankle Torque Cylinders: The following check should be performed when inspecting for post-test damage: (These can be viewed with the potentiometers and bearing housings removed from each side of the ankle assembly.)

Check for permanent compression, nicks or tears

Tibia Compliant bushing Assembly: The following checklist should be used when inspecting for post-test damage:

Check for alignment and correct motion in the lower tibia bearing housing.

Check the condition of the linear bearing lining.

Check the rubber bushing for signs of permanent compression, debonding

Tibia Skin: The following check should be performed when inspecting for post-test damage:

Check for holes, tears and cuts.

Foot Skin: The following check should be performed when inspecting for post-test damage:

Check for holes, tears and cuts.