



# Cisco 7206 VXR NPE-G2 with VSA FIPS 140-2 Non-Proprietary Security Policy

---

Level 2 Validation  
Version 1.1  
July 2011

## Table of Contents

Introduction	2
References	2
Document Organization	2
Module Descriptions	3
Cisco 7206VXR NPE-G2	3
Cisco VPN Services Adapter (VSA)	3
Module Validation Level	3
Cryptographic Module	4
Module Interfaces	4
Roles, Services & Authentication	5
User Services	6
Cryptographic Key Management	7
Self-Tests	11
Secure Operation	12
System Initialization and Configuration	13
IPSec Requirements & Cryptographic Algorithms	14
Protocols	14
Remote Access	14



Americas Headquarters:  
Cisco Systems, Inc., 170 West Tasman Drive, San Jose, CA 95134-1706 USA  
© 2010 Cisco Systems, Inc. All rights reserved.  
This document may be freely reproduced and distributed whole and intact including this copyright notice

---

Tamper Evidence	15
7206VXR NPE-G2 with VSA	15
Acronym	17
Obtaining Documentation, Support & Security Guidelines	18

## Introduction

This is a non-proprietary Cryptographic Module Security Policy for the 7206VXR NPE-G2 with VSA from Cisco Systems, Inc., referred to in this document as the modules, routers, or by the specific model name. This security policy describes how modules meet the security requirements of FIPS 140-2 and how to run the modules in a FIPS 140-2 mode of operation.

This policy was prepared as part of the FIPS 140-2 Level 2 validation of the following module:

- 7206VXR NPE-G2 with VSA

FIPS 140-2 (Federal Information Processing Standards Publication 140-2: *Security Requirements for Cryptographic Modules*) details the U.S. Government requirements for cryptographic modules. More information about the FIPS 140-2 standard and validation program is available on the NIST website at <http://csrc.nist.gov/groups/STM/index.html>.

## References

This document deals only with operations and capabilities of the module in the technical terms of a FIPS 140-2 cryptographic module security policy. More information is available on the module from the following sources:

- The Cisco Systems website <http://www.cisco.com> contains information on the full line of products from Cisco Systems.
- The NIST Cryptographic Module Validation Program website <http://csrc.nist.gov/groups/STM/index.html> contains contact information for answers to technical or sales-related questions for the module.

## Document Organization

The Security Policy document is one document in a FIPS 140-2 Submission Package. In addition to this document, the Submission Package contains:

Vendor Evidence document

Finite State Machine

Other supporting documentation as additional references

With the exception of this Non-Proprietary Security Policy, the FIPS 140-2 Validation Documentation is proprietary to Cisco Systems, Inc. and is releasable only under appropriate non-disclosure agreements. For access to these documents, please contact Cisco Systems, Inc.

---

# Module Descriptions

## Cisco 7206VXR NPE-G2

Cisco 7206 VXR routers are designed to support gigabit capabilities and to improve data, voice, and video integration in both service provider and enterprise environments. Cisco 7206 VXR routers support a high-speed network processing engines like NPE-G2 and all other available network processing engines.

Cisco 7206 VXR routers accommodate a variety of network interface port adapters and an Input/Output (I/O) controller. A Cisco 7206 VXR router equipped with NPE-G2 can support up to six high-speed port adapters and can also support higher-speed port adapter interfaces including Gigabit Ethernet and OC-12 ATM (Optical Carrier-12 Asynchronous Transfer Mode). In addition, a Cisco

7206VXR router with an NPE-G2 provides integrated I/O functionality. Cisco 7206 VXR routers also contain bays for up to two AC-input or DC-input power supplies.

Cisco 7206 VXR routers support the following features:

Online insertion and removal (OIR): Add, replace or remove port adapters without interrupting the system.

Dual hot-swappable, load-sharing power supplies: Provide system power redundancy; if one power supply or power source fails, the other power supply maintains system power without interruption. Also, when one power supply is powered off and removed from the router, the second power supply immediately takes over the router power requirements without interrupting normal operation of the router.

Environmental monitoring and reporting functions: Maintain normal system operation by resolving adverse environmental conditions prior to loss of operation.

Downloadable software: Load new images into Flash memory remotely, without having to physically access the router. This capability is not permitted in FIPS mode of operations, however.

## Cisco VPN Services Adapter (VSA)

The Cisco 7206VXR NPE-G2 routers incorporate the VPN Services Adapter (VSA) cryptographic accelerator card that fits into the I/O controller slot of the 7206VXR. The VSA features hardware acceleration for various cryptographic algorithms, providing increased performance for site-to-site and remote-access IPSec VPN services. The Cisco VSA supports full Layer 3 routing, quality of service (QoS), multicast and multiprotocol traffic, and broad support of integrated LAN/WAN media. The VSA off-loads IPSec processing from the main processor, thus freeing resources on the processor engines for other tasks.

The evaluated platform consists of the following:

7206VXR Hardware Version 2.9

NPE-G2 Hardware Version 1.0

VSA Hardware Version 1.0

## Module Validation Level

The following table lists the level of validation for each area in the FIPS PUB 140-2.

No.	Area Title	Level
1	Cryptographic Module Specification	2
2	Cryptographic Module Ports and Interfaces	2
3	Roles, Services, and Authentication	2
4	Finite State Model	2
5	Physical Security	2
6	Operational Environment	N/A
7	Cryptographic Key management	2
8	Electromagnetic Interface/Electromagnetic Compatibility	2
9	Self-Tests	2
10	Design Assurance	2
11	Mitigation of Other Attacks	N/A

## Cryptographic Module

The cryptographic boundary for the 7206VXR NPE-G2 with VSA is defined as encompassing the "top," "front," "left," "right," and "bottom" surfaces of the case; all portions of the "backplane" of the case which are not designed to accommodate a removable port adapter; the inverse of the three-dimensional space within the case that would be occupied by an installed port adapter and the VSA installed into the I/O controller slot. The cryptographic boundary includes VSA installed into the I/O controller slot and the connection apparatus between the port adapter and the motherboard/daughterboard that hosts the port adapter, but the boundary does not include the port adapter itself. In other words, the cryptographic boundary encompasses all hardware components within the case of the device except any installed modular port adapter.

All of the functionality discussed in this document is provided by components within this cryptographic boundary. Each module is a multi-chip standalone module.

## Module Interfaces

Each module provides a number of physical and logical interfaces to the device, and the physical interfaces provided by the module are mapped to four FIPS 140-2 defined logical interfaces: data input, data output, control input, and status output. The logical interfaces and their mapping are described in the following tables:

**Table 2 FIPS 140-2 Logical Interfaces: 7206VXR NPE-G2 with VSA**

Router Physical Interface	FIPS 140-2 Logical
10/100/1000 RJ-45 Port	Data Input Interface
SFP Gigabit Ethernet Port	
Port Adapter/Mid plane Interface	
Console Port	
Auxiliary Port	

10/100/1000 BASE-TX LAN Port Gigabit Ethernet Port Port Adapter Interface Console Port Auxiliary Port 10/100 Management Port	Data Output Interface
10/100/1000 BASE-TX LAN Port Gigabit Ethernet Port Port Adapter Interface Power Switch Reset Switch Console Port Auxiliary Port 10/100 Management Port	Control Input Interface
10/100/1000 BASE-TX LAN Port Port Adapter Interface Gigabit Ethernet Port LEDs Console Port Auxiliary Port 10/100 Management Port	Status Output Interface
Power Plug	Power Interface

## Roles, Services & Authentication

Authentication is role-based. There are two main roles in the router that operators may assume: the Crypto Officer role and the User role. The administrator of the router assumes the Crypto Officer role in order to configure and maintain the router using Crypto Officer services, while the Users exercise only the basic User services. The module supports RADIUS and TACACS+ for authentication. A complete description of all the management and configuration capabilities of the modules can be found in the Performing Basic System Management manual and in the online help for the modules.

The User and Crypto Officer passwords and the RADIUS/TACACS+ shared secrets must each be at least

8 characters long, including at least one letter and at least one number character, in length. See the Secure Operation section for more information. If 6 integers, one special character and one alphabet are used without repetition for an 8 digit PIN, the probability of randomly guessing the correct sequence is

1 in 832,000,000. In order to successfully guess the sequence in one minute would require the ability to make over 13,000,000 guesses per second, which far exceeds the operational capabilities of the module. Including the rest of the alphanumeric characters drastically decreases the odds of guessing the correct sequence.”

The 7206 can also use certificate credentials using 1024 bit RSA keys and SHA-1 – in such a case the security strength is 80 bits, so an attacker would have a 1 in  $2^{80}$  chance of a successful authentication which is much stronger than the one in a million chance required by FIPS 140-2. To exceed a one in 100,000 probability of a successful random key guess in one minute, an attacker would have to be capable of approximately  $1.8 \times 10^{21}$  attempts per minute, which vastly exceeds the operational capabilities of the module to support.

---

## User Services

A User enters the system by accessing the console/auxiliary port with a terminal program or via IPSec protected Telnet or SSH v2 session to a LAN port. The IOS prompts the User for their password. If the password is correct, the User is allowed entry to the IOS executive program. The services available to the User role consist of the following:

- Status Functions: View state of interfaces and protocols, version of IOS currently running
- Network Functions: Connect to other network devices through outgoing telnet, PPP, etc. and initiate diagnostic network services (i.e., ping, mtrace)
- Terminal Functions: Adjust the terminal session (e.g., lock the terminal, adjust flow control)
- Directory Services: Display directory of files kept in flash memory
- Get VPN service: Negotiation and encrypted data transport via Get VPN
- Perform Self-Tests: Perform the FIPS 140 start-up tests on demand

## Crypto Officer Services

A Crypto Officer enters the system by accessing the console/auxiliary port with a terminal program or via IPSec protected telnet or SSH v2 session to a LAN port. The Crypto Officer authenticates as a User and then authenticates as the Crypto Officer role.. During initial configuration of the router, the Crypto Officer password (the “enable” password) is defined. A Crypto Officer may assign permission to access the Crypto Officer role to additional accounts, thereby creating additional Crypto Officers.

- The Crypto Officer role is responsible for the configuration and maintenance of the router. The Crypto Officer services consist of the following:
- Configure the Router—Define network interfaces and settings, create command aliases, set the protocols the router will support, enable interfaces and network services, set system date and time, and load authentication information.
- Define Rules and Filters—Create packet Filters that are applied to User data streams on each interface. Each Filter consists of a set of Rules, which define a set of packets to permit or deny based characteristics such as protocol ID, addresses, ports, TCP connection establishment, or packet direction.
- Status Functions—View the router configuration, routing tables, active sessions, use get commands to view SNMP MIB statistics, health, temperature, memory status, voltage, packet statistics, review accounting logs, and view physical interface status.
- Manage the Router—Log off users, shutdown or reload the router, manually back up router configurations, view complete configurations, manager user rights, and restore router configurations.
- Set Encryption/Bypass—Set up the configuration tables for IP tunneling. Set keys and algorithms to be used for each IP range or allow plaintext packets to be set from specified IP address.
- Change Port Adapters—Insert and remove adapters in a port adapter slot.
- Change VSA—Insert and remove VSA in an I/O Controller slot. (This service available only for 7206VXR NPE-G2 with VSA)

- Perform Self-Tests: Perform the FIPS 140 start-up tests on demand

## Unauthenticated Services

- Observe L.E.D. status
- Perform Power up Self-Test
- Perform Bypass Function

## Cryptographic Key Management

The router securely administers both cryptographic keys and other critical security parameters such as passwords. The tamper evidence seals provide physical protection for all keys. All keys are also protected by the password-protection on the Crypto Officer role login, and can be zeroized by the Crypto Officer. All zeroization consists of overwriting the memory that stored the key. Keys are exchanged and entered electronically or via Internet Key Exchange (IKE).

The module supports the following critical security parameters (CSPs):

**Table 4** Critical Security Parameters

CSP Name	Description	Storage
CSP 1	This is the seed key for X9.31 RNG. This key is stored in DRAM and updated periodically after the generation of 400 bytes; hence, it is zeroized periodically. Also, the operator can turn off the router to zeroize this key.	DRAM (plaintext)
CSP 2	The public and private exponents used in Diffie-Hellman (DH) exchange. Zeroized after DH shared secret has been generated.	DRAM (plaintext)
CSP 3	The shared secret within IKE exchange. Zeroized when IKE session is terminated.	DRAM (plaintext)
CSP 4	Same as above	DRAM (plaintext)
CSP 5	Same as above	DRAM (plaintext)
CSP 6	Same as above	DRAM (plaintext)
CSP 7	The IKE session encrypt key. The zeroization is the same as above.	DRAM (plaintext)
CSP 8	The IKE session authentication key. The zeroization is the same as above.	DRAM (plaintext)
CSP 9	The key used to generate IKE skeyid during preshared-key authentication. The <b>no crypto isakmp key</b> command zeroizes it. This key can have two forms based on whether the key is related to the <u>hostname</u> or the <u>IP address</u> .	NVRAM (plaintext)
CSP 10	This key generates keys 3, 4, 5 and 6. This key is zeroized after generating those keys.	DRAM (plaintext)

CSP 11	The fixed key used in Cisco vendor ID generation. This key is embedded in the module binary image and can be deleted by erasing the Flash.	NVRAM (plaintext)
CSP 12	The IPSec encryption key. Zeroized when IPSec session is terminated.	DRAM (plaintext)
CSP 13	The IPSec authentication key. The zeroization is the same as above.	DRAM (plaintext)
CSP 14	This key is used by the router to authenticate itself to the peer. The router itself gets the password (that is used as this key) from the AAA server and sends it onto the peer. The password retrieved from the AAA server is zeroized upon completion of the authentication attempt.	DRAM (plaintext)
CSP 15	The authentication key used in PPP. This key is in the DRAM and not zeroized at runtime. One can turn off the router to zeroize this key because it is stored in DRAM.	DRAM (plaintext)
CSP 16	This key is used by the router to authenticate itself to the peer. The key is retrieved from the local database (on the router itself). Issuing the <b>no username password</b> command zeroizes the password (that is used as this key) from the local database.	NVRAM (plaintext)
CSP 17	The password of the User role. This password is zeroized by overwriting it with a new password.	NVRAM (plaintext)
CSP 18	The plaintext password of the CO role. This password is zeroized by overwriting it with a new password.	NVRAM (plaintext)
CSP 19	The ciphertext password of the CO role. However, the algorithm used to encrypt this password is not FIPS approved. Therefore, this password is considered plaintext for FIPS purposes. This password is zeroized by overwriting it with a new password.	NVRAM (plaintext)
CSP 20	The RADIUS shared secret. This shared secret is zeroized by executing the “no” form of the RADIUS shared secret set command.	NVRAM (plaintext), DRAM
CSP 21	The TACACS+ shared secret. This shared secret is zeroized by executing the “no” form of the RADIUS shared secret set command.	NVRAM (plaintext), DRAM
CSP 22	The SSH session key. It is zeroized automatically when the SSH session is terminated.	DRAM (plaintext)
CSP 23	The keys and CSPS above from no.1 to 21 are located in the router outside VSA	DRAM (plaintext)
CSP 24	GDOI TEK algorithm key - This key is created using the “GROUPKEY-PULL” registration protocol and updated using the “GROUPKEY-PUSH” registration protocol with GDOI. It is used to encrypt data traffic between Get VPN peers	DRAM (plaintext)



CSP 25	GDOI KEK algorithm key - This key is created using the “GROUPKEY-PULL” registration protocol with GDOI. It is used protect GDOI rekeying data.”	DRAM (plaintext)
CSP 26	GDOI TEK integrity key	DRAM (plaintext)
CSP 27	Diffie Hellman private exponent - The private exponent used in Diffie-Hellman (DH) exchange as part of IKE. Zeroized after DH shared secret has been generated.	DRAM (plaintext)
CSP 28	RSA private exponent - The private exponent used in RSA exchange as part of IKE and SSH. Zeroized after RSA shared secret has been generated.	DRAM (plaintext)

1. This key not present in 7206VXR NPE-G2 with VSA.

The services accessing the CSPs, the type of access and which role accesses the CSPs are listed in [Table 5](#). The module supports IOS implementations of Triple-DES, DES-MAC, Triple-DES-MAC, AES, SHA-1, HMAC SHA-1, MD5, HMAC MD5, Diffie-Hellman, RNG and RSA cryptographic algorithms. Except for SHA-1 and RNG none of the other software algorithm implementations are used when operating in FIPS mode. IOS implementation of Diffie-Hellman is used in all module configurations except 7206VXR NPE-G2 with VSA which uses hardware implementation of DH.



**NOTE:** Pursuant to the DES Transition Plan and the approval of the Withdrawal of Federal Information Processing Standard (FIPS) 46-3, Data Encryption Standard (DES); FIPS 74, Guidelines for Implementing and Using the NBS Data Encryption Standard; and FIPS 81, DES Modes of Operation, the DES algorithm shall not be used in FIPS approved mode of operation.

**Table 5 Role and Service Access to CSPs**

SRDI/Role/Service Access Policy	Security Relevant Data Item	CSP 1	CSP 2	CSP 3	CSP 4	CSP 5	CSP 6	CSP 7	CSP 8	CSP 8	CSP 10	CSP 11	CSP 12	CSP 13	CSP 14	CSP 15	CSP 16	CSP 17	CSP 18	CSP 19	CSP 20	CSP 21	CSP 22	CSP 23	CSP 24	CSP 25	CSP 26	CSP 27	CSP 28
<b>Role/Service</b>																													
<b>User role</b>																													
<b>Status Functions</b>																													
<b>Network Functions</b>		r	r	r	r	r	r	r	r	r	r	r	r	r	r	r	r	r											
<b>Terminal Functions</b>																													
<b>Directory Services</b>																													
<b>Get VPN</b>																													
<b>Crypto-Officer Role</b>																													
<b>Configure the Router</b>												rw d					rw d												
<b>Define Rules and Filters</b>																													
<b>Status Functions</b>																													
<b>Manage the Router</b>		d													rw d	d		rw d	rw d	rw d	rw d	rw d	rw d	rw d					
<b>Set Encryption/Bypass</b>		rw d	rw d	rw d	rw d	rw d	rw d	rw d	rw d	rw d	rw d		rw d	rw d		rw													
<b>Change Port Adapters</b>																													
<b>Change VSA</b>																													

Each cryptographic implementation has achieved the following validations:

**Table 6** Algorithm Certificates

Algorithm	IOS (NPE-G2)	VSA
AES	Not supported in FIPS mode	91
Triple-DES	Not supported in FIPS mode	204
SHA-1	1303	500
HMAC SHA-1	Not supported in FIPS mode	203
RNG	786	-
RSA	Not supported in FIPS mode	707

The module supports the following key management schemes:

Pre-shared key exchange via electronic key entry. Triple-DES/AES key and HMAC-SHA-1 key are exchanged and entered electronically.

Internet Key Exchange method with support for pre-shared keys exchanged and entered electronically.

- The pre-shared keys are used with Diffie-Hellman key agreement technique to derive DES, Triple-DES or AES keys.
- The pre-shared key is also used to derive HMAC-SHA-1 key.

The Diffie-Hellman key establishment methodology provides 80 or 96 bits of encryption strength. GDOI Key wrapping, key establishment methodology provides between 128 bits and 256 bits of encryption strength per NIST 800-57.

All pre-shared keys are associated with the CO role that created the keys, and the CO role is protected by a password. Therefore, the CO password is associated with all the pre-shared keys. The Crypto Officer needs to be authenticated to store keys. All Diffie-Hellman (DH) keys agreed upon for individual tunnels are directly associated with that specific tunnel only via the IKE protocol. All of the keys and CSPs of the module can be zeroized. Please refer to [Figure 4](#) for information on methods to zeroize each key and CSP.

## Self-Tests

The modules include an array of self-tests that are run during startup and periodically during operations to prevent any secure data from being released and to insure all components are functioning correctly. The modules implement the following power-on self-tests:

**Table 7            Module Power On Self Tests**

<b>Implementation</b>	<b>Tests Performed</b>
IOS	Software/firmware test Bypass test SHA-1 KAT RNG KAT
VSA	Firmware integrity test Triple-DES KAT AES KAT SHA-1 KAT HMAC-SHA-1 KAT RSA KAT DH Test

1. IOS implementation of DH is not used in 7206VXR NPE-G2 with VSA.

The modules perform all power-on self-tests automatically at boot. All power-on self-tests must be passed before any operator can perform cryptographic services. The power-on self-tests are performed after the cryptographic systems are initialized but prior to the initialization of the LANs; this prevents the module from passing any data during a power-on self-test failure.

In addition, the module also provides the following conditional self-tests:

**Table 8            Module Conditional Self Tests**

<b>Implementation</b>	<b>Tests Performed</b>
IOS	<ul style="list-style-type: none"><li>• Continuous Random Number Generator test for the FIPS-approved RNG</li><li>• Continuous Random Number Generator test for the non-approved RNGs</li><li>• Conditional Bypass test</li><li>• RSA PWCT</li></ul>
VSA	<ul style="list-style-type: none"><li>• Continuous Random Number Generator test for the non-approved RNG</li></ul>

## Secure Operation

These routers meet all the applicable Level 2 requirements for FIPS 140-2. Follow the setting instructions provided below to place the module in FIPS mode. Operating this router without maintaining the following settings will remove the module from the FIPS approved mode of operation. All configuration activities must be performed via the command line interface via the console (for initial configuration) or IPSec protected SSH v2 or telnet sessions – neither the web configuration tools CSRW or SDM may be used.

---

## System Initialization and Configuration

---

**Step 1** The Crypto Officer must perform the initial configuration. The following advanced enterprise builds are the only allowable images; no other image may be loaded.

- 7206VXR NPE-G2 with VSA: c7200-adventerprisek9-mz.124-15.T10 (IOS version 12.4(15)T10) and c7200-adventerprisek9-mz.124-15.T14 (IOS version 12.4(15)T14)

**Step 2** The value of the boot field must be 0x0102. This setting disables break from the console to the ROM monitor and automatically boots the IOS image. From the “configure terminal” command line, the Crypto Officer enters the following syntax:

```
config-register 0x0102
```

**Step 3** The Crypto Officer must enter the following command to prevent failover to software implementation:

```
no crypto engine software ipsec
```

**Step 4** The Crypto Officer must create the “enable” password for the Crypto Officer role. The password must be at least 8 characters, including at least one letter and at least one number, and is entered when the Crypto Officer first engages the “enable” command. The Crypto Officer enters the following syntax at the “#” prompt:

```
enable secret [PASSWORD]
```

**Step 5** The Crypto Officer must always assign passwords (of at least 8 characters, including at least one letter and at least one number) to users. Identification and authentication on the console/auxiliary port is required for Users. From the “configure terminal” command line, the Crypto Officer enters the following syntax:

```
line con 0
password [PASSWORD]
login local
```

**Step 6** The Crypto Officer shall not assign users to privilege level other than Level 1 (the default).

**Step 7** The Crypto Officer may configure the module to use RADIUS or TACACS+ for authentication.

Configuring the module to use RADIUS or TACACS+ for authentication is optional. If the module is configured to use RADIUS or TACACS+, the Crypto-Officer must define RADIUS or TACACS+ shared secret keys that are at least 8 characters long, including at least one letter and at least one number.

**Step 8** The Crypto Officer must apply tamper evidence labels as described later in this document.

**Step 9** The module must be configured to only use hardware acceleration. As such if there is a failure in the VSA card, the module is considered to be out of FIPS-Approved Mode of operation.

A failure in the integrity check for VSA will be indicated via the following console message:

---

VSA boot error: POST FAILURE

The status of the VSA can also be verified with the **show crypto engine accelerator statistic** and **show crypto eli** commands.



**NOTE:** The keys and CSPs generated in the cryptographic module during FIPS mode of operation cannot be used when the module transitions to non-FIPS mode and vice versa. While the module transitions from FIPS to non-FIPS mode or from non-FIPS to FIPS mode, all the keys and CSPs are to be zeroized by the Crypto Officer.



## IPSec Requirements & Cryptographic Algorithms

---

**Step 1** The only type of key management that is allowed in FIPS mode is Internet Key Exchange (IKE).

**Step 2** Although the IOS implementation of IKE allows a number of algorithms, only the following algorithms are allowed in a FIPS 140-2 configuration:

- ah-sha-hmac
- esp-sha-hmac
- esp-3des
- esp-aes

**Step 3** The following algorithms shall not be used:

- MD-5 for signing
- MD-5 HMAC
- DES
- Software implementations of AES, DES, Triple-DES, SHA-1, and HMAC

---

## Protocols

---

**Step 1** SNMP v3 over a secure IPSec tunnel may be employed for authenticated, secure SNMP *gets* and *sets*.

Since SNMP v2C uses community strings for authentication, only *gets* are allowed under SNMP v2C.

**Step 2** Secure DNS is not allowed in FIPS mode of operation and shall not be configured.

---

## Remote Access

---

**Step 1** Telnet access to the module is only allowed via a secure IPSec tunnel between the remote system and the module. The Crypto officer must configure the module so that any remote

---

connections via telnet are secured through IPSec, using FIPS-approved algorithms. Note that all users must still authenticate after remote access is granted.

- Step 2** SSH access to the module is allowed in FIPS approved mode of operation, using SSH v2 and a FIPS approved algorithm.
- 

## Tamper Evidence

All Critical Security Parameters are stored and protected within each appliance's tamper evident enclosure. The administrator is responsible for properly placing all tamper evident labels. The security labels for FIPS 140-2 compliance are provided in the FIPS Kit:

Product Number: CVPN7200FIPS/KIT=

Product Description: Kit(Instructions,labels)to configure 7206 for FIPS operation

These security labels are very fragile and cannot be removed without clear signs of damage to the labels.

The Crypto Officer should inspect the tamper evident labels periodically to verify they are intact and the serial numbers on the applied tamper evident labels match the records in the security log.

Any port adapter slot not populated with a port adapter must be populated with an appropriate slot cover in order to operate in a FIPS compliant mode. The slot covers are included with each router, and additional covers may be ordered from Cisco. The same procedure mentioned below to apply tamper evidence labels for port adapters must also be followed to apply tamper evidence labels for the slot covers.

The Tamper evident labels (12) shall be installed for the module to operate in FIPS mode.

## 7206VXR NPE-G2 with VSA

The front of the router provides 6 port adapter slots (An additional port adapter slot is available when a port adapter jacket card is inserted into the I/O controller slot), and the rear of the router provides

on-board LAN connectors, PC Card slots, and Console/Auxiliary connectors. The power cable connection, a power switch, and the access to the Network Processing Engine are at the rear of the router.

Once the router has been configured to meet FIPS 140-2 Level 2 requirements, the router cannot be accessed without signs of tampering. The Crypto Officer shall be instructed to record serial numbers, and to inspect for these signs of tampering or changed numbers periodically.

To seal the system, apply serialized tamper-evidence labels as depicted in [Figure 1](#) and [Figure 2](#) as follows:

- 
- Step 1** Clean the cover of any grease, dirt, or oil before applying the tamper evidence labels. Alcohol-based cleaning pads are recommended for this purpose. The ambient air must be above 10°C, otherwise the labels may not properly cure.
- Step 2** A tamper evidence label shall be placed so that the one half of the label covers the enclosure and the other half covers the NPE-G2.

- Step 3** A tamper evidence label shall be placed over the Compact Flash card slot on the NPE-G2.
- Step 4** A tamper evidence label shall be placed over the USB ports of the NPEG2.
- Step 5** A tamper evidence label shall be placed so that one half of the label covers the enclosure and the other half covers the port adapter slot 1.
- Step 6** A tamper evidence label shall be placed so that one half of the label covers the enclosure and the other half covers the port adapter slot 2.
- Step 7** A tamper evidence label shall be placed so that one half of the label covers the enclosure and the other half covers the port adapter slot 3.
- Step 8** A tamper evidence label shall be placed so that one half of the label covers the enclosure and the other half covers the port adapter slot 4.
- Step 9** A tamper evidence label shall be placed so that one half of the label covers the enclosure and the other half covers the port adapter slot 5.
- Step 10** A tamper evidence label shall be placed so that one half of the label covers the enclosure and the other half covers the port adapter slot 6.
- Step 11** A tamper evidence label shall be placed such that one half of the label covers the enclosure and the other half covers the VSA.
- Step 12** A tamper evidence label shall be placed so that one half of the label covers the enclosure and the other half covers the power supply plate.
- Step 13** A tamper evidence label shall be placed so that one half of the label covers the enclosure and the other half covers the redundant power supply plate.
- Step 14** Allow the labels to cure for five minutes.

**Figure 1** Cisco 7206VXR (Front) Tamper Evident Label Placement

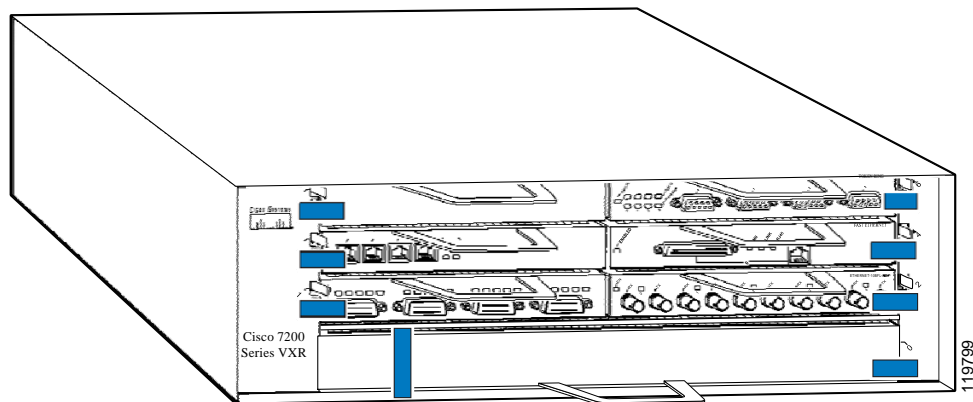



**Figure 2 Cisco 7206VXR (Back) Tamper Evident Label Placement**

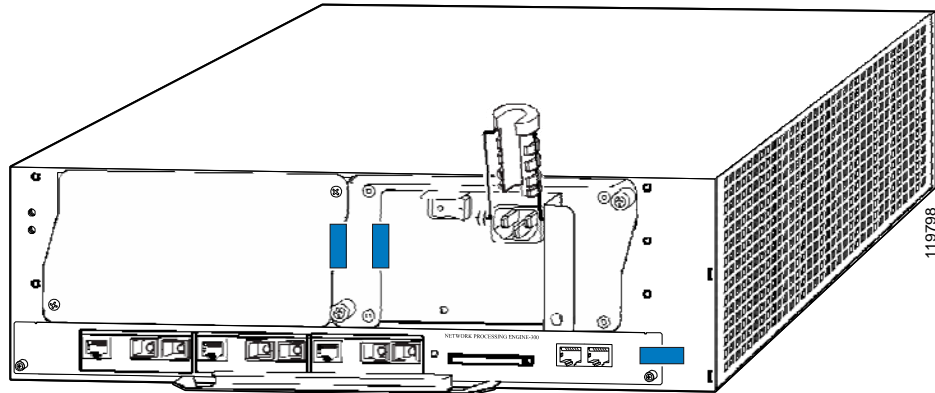

## Acronyms

AAA	Authentication, Authorization and Accounting
AES	Advanced Encryption Standard
CMVP	Cryptographic Module Validation Program
CSP	Critical Security Parameter
DES	Data Encryption Standard
FIPS	Federal Information Processing Standard
HTTP	Hyper Text Transfer Protocol
KAT	Known Answer Test
LED	Light Emitting Diode
NPE	Network Processing Engine
NIST	National Institute of Standards and Technology
NVLAP	National Voluntary Laboratory Accreditation Program
PPP	Point to Point Protocol
RAM	Random Access Memory
RSA	Rivest, Shamir, & Adleman [method for asymmetric encryption]
SHA	Secure Hash Algorithm
VAM	VPN Acceleration Module

---

## Obtaining Documentation, Support & Security Guidelines

For information on obtaining Cisco documentation, security guidelines, recommended aliases, support and a means to provide documentation feedback, see the monthly [What's New in Cisco Product Documentation](#), which also lists new and revised Cisco technical documentation.

To find an HTML or PDF version of many Cisco titles go to [www.cisco.com](http://www.cisco.com). Type the title in the 'Search' field and click **Go**.

---

Cisco and the Cisco Logo are trademarks of Cisco Systems, Inc. and/or its affiliates in the U.S. and other countries. A listing of Cisco's trademarks can be found at [www.cisco.com/go/trademarks](http://www.cisco.com/go/trademarks). Third party trademarks mentioned are the property of their respective owners. The use of the word partner does not imply a partnership relationship between Cisco and any other company. (1005R).