



3e Technologies International, Inc.
FIPS 140-2
Non-Proprietary Security Policy
Level 2 Validation

3e-525A-3,
3e-525A-3 BASIC,
3e-525A-3 BASIC with TEC,
3e-525A-3MP,
3e-525A-3MP with TEC,
3e-525V-3, 3e-525Ve-3, 3e-525Ve-4
AirGuard™ Wireless Access Points

Tested with
HW Version 2.0(A)
FW Versions 4.3.3, 4.3.3, 4.3.3, 4.3.3, 4.3.3,
4.3.3, 4.3.3, 4.3.2

Security Policy Version 2.1

December 05, 2008

Copyright ©2008 by 3e Technologies International.
This document may freely be reproduced and distributed in its entirety.

- 1. INTRODUCTION..... 1**
- 2. REFERENCES..... 1**
- 3. AIRGUARD WIRELESS ACCESS POINT 2**
 - 3.1. CRYPTOGRAPHIC MODULE 2
 - 3.2. MODULE INTERFACES 4
 - 3.3. ROLES AND SERVICES 6
 - 3.3.1. *Crypto Officer and Administrator Role Services* 7
 - 3.3.2. *User Role Services* 10
 - 3.3.3. *Security Server Role Services* 11
 - 3.3.4. *Unauthenticated Services*..... 11
 - 3.4. CRYPTOGRAPHIC ALGORITHMS 12
 - 3.5. CRYPTOGRAPHIC KEYS AND SRDIS..... 13
 - 3.6. SELF-TESTS 20
 - 3.7. SECURE OPERATION OF THE AIRGUARD WIRELESS ACCESS POINT 20
 - 3.7.1. *Applying Tamper-Evident Seals (All Models)*..... 21
 - 3.7.2. *Checking for Tamper Evidence*..... 26
- GLOSSARY..... 29**

1. Introduction

This document describes the non-proprietary cryptographic module security policy for 3e Technologies International's wireless gateway product variations, the *3e-525A-3*, *3e-525A-3 BASIC*, *3e-525A-3 BASIC with TEC*, *3e-525A-3MP*, *3e-525A-3MP with TEC*, *3e-525V-3*, *3e-525Ve-3*, *3e-525Ve-4 AirGuard™ Wireless Access Points* (tested with Hardware Version: HW V2.0(A); Firmware Versions 4.3.3, 4.3.3, 4.3.3, 4.3.3, 4.3.3, 4.3.3, 4.3.3, 4.3.2). Please note other HW and FW versions may be vendor-affirmed. This policy was created to satisfy the requirements of FIPS 140-2 Level 2. This document defines 3eTI's security policy and explains how the gateway product variations meet the FIPS 140-2 security requirements.

The cryptographic module security policy consists of a specification of the security rules, under which the cryptographic module shall operate, including the security rules derived from the requirements of the standard. Please refer to FIPS 140-2 (Federal Information Processing Standards Publication 140-2 — *Security Requirements for Cryptographic Modules* available on the NIST website at <http://csrc.nist.gov/groups/STM/index.html>.

2. References

- *AirGuard™ Wireless Access Point User's Guide*, Model 3e-525A-3, Model 3e-525A-3 Basic, Model 3e-525A-3MP, 6/3/08.
- *Installation Guide for the 3e525A-3MP Wireless Access Point with Mobile Power*, document Revision A.

3. AirGuard Wireless Access Point

3.1. Cryptographic Module

The eight variants of the 525A-3 AirGuard Wireless Access Point module (the module) are devices, which consist of electronic hardware, embedded software and strong metal case. There are two different types of metal cases, one for non-MP models, and one for MP models, as depicted in the figures below. For purposes of FIPS 140-2, the module is considered to be a multi-chip standalone product. The 525A-3/525V-3/525Ve-3/525Ve-4 product variants operate as either a gateway connecting a local area network to wide area network (WAN) or as an access point within a local area network (LAN).

The 525V-3/Ve-3/Ve-4 products are simply 525A-3 units that contain separate video-processing printed circuit boards (entirely isolated from all cryptographic functionality). The 525V-3 contains an older Axis video board, with separate video and camera PTZ interface ports. The 525Ve-3 contains a newer Mango video board, with a video port only (no camera PTZ port). The 525Ve-4 contains a different Mango video board with dual video ports, as well as a separate camera PTZ port.

In summary, the eight variants of the module differ from each other as follows:

1. 525A-3 has mil-spec-461 compliant filters. Uses Power Over Ethernet (POE). Executes firmware 4.3.3.
2. 525A-3 BASIC does not have the mil-spec-461-compliant filtering. Uses POE. Executes firmware 4.3.3.
3. 525A-3 BASIC w/TEC is a variant of #2 above with a thermo-electric cooler installed. Executes firmware 4.3.3.
4. 525A-3MP has power (24V nominal) entering through the antenna panel. Executes firmware 4.3.3.
5. 525A-3MP w/TEC is a variant of #4 above with a thermo-electric cooler installed. Executes firmware 4.3.3.
6. 525V-3 is a variant of #1 above with older Axis video processing board. Executes firmware 4.3.3.
7. 525Ve-3 is a variant of #1 above with newer Mango video board and video port only. Executes firmware 4.3.3.
8. 525Ve-4 is a variant of #1 above with newer Mango video board and dual video ports as well as camera PTZ port. Executes firmware 4.3.2.

The term *TEC* in two of the variants stands for *Thermo-Electric Cooler*. It is circuitry included within the unit to extend the temperature range of the unit. It is used to pump heat energy away from the WLAN circuit boards to the enclosure case in warm environment.

The cryptographic boundary of the 525A-3/525V-3/525Ve-3/525Ve-4 product variants is defined to be the entire enclosure of the Gateway. The 525A-3/525V-3/525Ve-3/525Ve-4

product variants are physically bound by the mechanical enclosure, which is protected by tamper evident tape.

525A-3 metal case

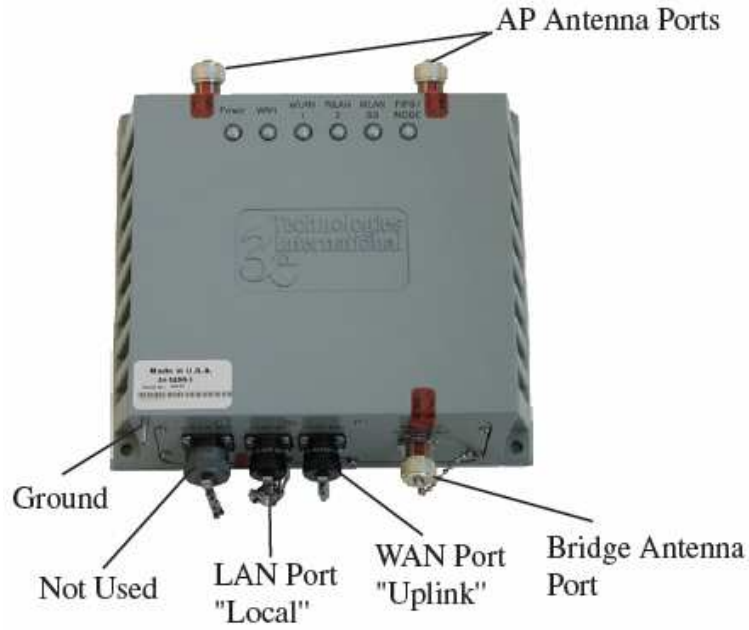

525A-3MP models' power port on AP Antennae panel



3e-525V-3

Additionally, there is no separate power port for the "-3" models (they use Power over Ethernet a.k.a. PoE), while there is a separate DC power port for the "MP" models.

The following table summarizes module interfaces when the module is operating in access point mode:

FIPS interface	Module interface
Data input	Local antennae (2)
	Bridging antenna (if enabled)
	WAN port
	Video (525-"V" models only)
Data output	Local antennae (2)
	Bridging antenna (if enabled)
	WAN port
	Camera PTZ (525-"V" models only)
Control input	LAN port
Status output	LEDs: <ul style="list-style-type: none"> • Power • WAN • WLAN 1 • WLAN 2 • WLAN SS • FIPS/MODE
	LAN port
Power port	WAN port (PoE)
	MP port (DC) (Mobile Power models only)

The following table summarizes module interfaces when the module is operating in gateway mode:

FIPS interface	Module interface
Data input	Local antennae
	Bridging antenna (if enabled)
	LAN port
	WAN port
Data output	Video (525-"V" models only)
	Local antennae
	Bridging antenna (if enabled)
	LAN port
Control input	WAN port
	Camera PTZ (525-"V" models only)

Status output	LEDs: <ul style="list-style-type: none"> • Power • WAN • WLAN 1 • WLAN 2 • WLAN SS • FIPS/MODE
	LAN port
	WAN port
Power port	WAN port (PoE)
	MP port (DC) (Mobile Power models only)

3.3. Roles and Services

The 525A-3/525V-3/525Ve-3/525Ve-4 product variants support four separate roles. The set of services available to each role is defined in this section. The 525A-3/525V-3/525Ve-3/525Ve-4 product variants authenticate an operator’s role by verifying his PIN or access to a shared secret.

The following table identifies the strength of authentication for each authentication mechanism supported:

Authentication Mechanism ¹	Strength of Mechanism
Userid and password	Minimum 8 characters => $94^8 = 1.641E-16$
Static Key (TDES or AES)	TDES (192-bits) or AES (128, 192, or 256-bits)
AES CCM pre-shared key	Minimum 8 characters => $94^8 = 6.095E15$

The module halts (introduces a delay) for a second after each unsuccessful authentication attempt by CO or Admin. The highest rate of authentication attempts to the module is one attempt per second. This translates to 60 attempts per minute. Therefore the probability for multiple attempts to use the module's authentication mechanism during a one-minute period is $60/(94^8)$, or less than $(9.84E-15)$.

¹ The module implements one authentication mechanism that authenticates individual operators into Crypto Officer and Administrator roles: the web GUI username/password mechanism. The module implements three authentication mechanisms that implicitly authenticate operators into a single User operator role: 3eTI static pre-shared key mechanism, 802.11i pre-shared key mechanism, 3eTI bridging pre-shared key mechanism. The module relies on an authentication server in the environment to authenticate User operators for 3eTI DKE and 802.11i EAP-TLS Approved encrypting modes.

3.3.1. Crypto Officer and Administrator Role Services

Crypto Officer Role: The Crypto officer role performs all security functions provided by the 525A-3/525V-3/525Ve-3/525Ve-4 product variants. This role performs cryptographic initialization and management functions (e.g., module initialization, input/output of cryptographic keys and SRDIs, audit functions and user management). The Crypto officer is also responsible for managing the Administrator users. The Crypto officer must operate within the Security Rules and Physical Security Rules specified in Sections 3.1 and 3.2. The Crypto officer uses a secure web-based HTTPS connection to configure the 525A-3/525V-3/525Ve-3/525Ve-4 product variants. Up to ten Crypto Officers may be defined in the 525A-3/525V-3/525Ve-3/525Ve-4 product variants. The Crypto Officer authenticates to the 525A-3/525V-3/525Ve-3/525Ve-4 product variants using a username and password.

Administrator Role: This role performs general 525A-3/525V-3/525Ve-3/525Ve-4 product variants configuration such as defining the WLAN, LAN and DHCP settings, performing self-tests and viewing system log messages for auditing purposes. No CO security functions are available to the Administrator. The Administrator can also reboot the 525A-3/525V-3/525Ve-3/525Ve-4 product variants, if deemed necessary.

The Administrator must operate within the Security Rules as specified in Section 3.1 and always uses a secure web-based HTTPS connection to configure the 525A-3/525V-3/525Ve-3/525Ve-4 product variants. The Administrator authenticates to the 525A-3/525V-3/525Ve-3/525Ve-4 product variants using a username and password. Up to 5 operators who can assume the Administrator role can be defined. All Administrators are identical; i.e., they have the same set of services available. The Crypto Officer is responsible for managing (creating, deleting) Administrator users.

Crypto Officer and Administrator services, and the keys/CSPs that each role has access to using web GUI page to provide correspondence to the key/CSP are summarized in the table below. If there is no web GUI interface to input/output a key/CSP, neither the Crypto Officer nor the Administrator have access to it. Please see the table titled “RFC 2818 HTTPS Keys/CSPs” under section 3.5 of this document for a list of keys/CSPs used/generated as a result of executing the Web GUI service

Categories	Features	Operator Roles												
		CryptoOfficer					Administrator							
		Show ²	Set ³	Add ⁴	Delete ⁵	Default Reset ⁶	Show ⁷	Set ⁸	Add ⁹	Delete ¹⁰	Default Reset ¹¹			
System Configuration														
• General	Hostname	X	X			X	X	X						X
	Domain name	X	X			X	X	X						X

Categories	Features	Operator Roles									
		CryptoOfficer					Administrator				
		Show ²	Set ³	Add ⁴	Delete ⁵	Default Reset ⁶	Show ⁷	Set ⁸	Add ⁹	Delete ¹⁰	Default Reset ¹¹
	Date/Time	X	X			X	X	X			X
• WAN	DHCP client	X	X			X	X	X			X
	Static IP address	X	X			X	X	X			X
	10/100 MBps half/full duplex/auto	X	X			X	X	X			X
• LAN	IP address	X	X			X	X	X			X
	Subnet mask	X	X			X	X	X			X
• Operating Mode	Gateway – FIPS	X	X			X	X	X			X
	Gateway – Non-FIPS	X	X			X	X	X			X
	AP / Bridging Mode – FIPS	X	X			X	X	X			X
	AP / Bridging Mode – Non-FIPS	X	X			X	X	X			X
	AP / Bridging Mode – FIPS / IPv6	X	X			X	X	X			X
	AP / Bridging Mode – Non-FIPS / IPv6	X	X			X	X	X			X
Wireless Access Point											
• General	SSID	X	X			X	X	X			X
	Wireless Mode	X	X			X	X	X			X
	Channel Number	X	X			X	X	X			X
	• Enable / Disable Auto Selection										
	• Auto selection button	X	X			X	X	X			X
	Transmit Power Mode	X	X			X	X	X			X
	Fixed Power Level	X	X			X	X	X			X
	Beacon Interval	X	X			X	X	X			X
	RTS Threshold	X	X			X	X	X			X
	DTIM	X	X			X	X	X			X
	Basic Rates	X	X			X	X	X			X
	Preamble	X	X			X	X	X			X
	Enable / Disable Broadcast SSID	X	X			X	X	X			X
		SSID	X	X			X	X	X		
• Security	No Encryption	X	X			X					X
	Dynamic Key Management	X	X			X					X
	Triple-DES	X	X			X					X
	AES (128-/192-256-bit)	X	X			X					X
	FIPS 802.11i	X	X			X					X
• Wireless VLAN	Enable/Disable VLAN	X	X			X					X
	VLAN	X	X	X	X	X					X
• MAC Address Filtering	Enable/Disable	X	X			X	X				X
	Add/Delete entry Allow/Disallow Filter	X	X	X	X	X	X				X
• Rogue AP Detection	Enable/Disable	X	X			X	X	X			X
	Known AP MAC address Email / Display rogue AP	X	X	X	X	X	X	X			X
• Advanced	Load Balancing	X	X			X	X	X			X

Categories	Features	Operator Roles									
		CryptoOfficer					Administrator				
		Show ²	Set ³	Add ⁴	Delete ⁵	Default Reset ⁶	Show ⁷	Set ⁸	Add ⁹	Delete ¹⁰	Default Reset ¹¹
	Layer 2 Isolation	X	X			X	X	X			X
Wireless Bridge											
• General	Manual/Auto Bridge	X	X			X	X	X			X
	SSID	X	X			X	X	X			X
	Max Auto Bridge	X	X			X	X	X			X
	Bridge Priority	X	X			X	X	X			X
	Signal Strength Threshold	X	X			X	X	X			X
	Broadcast SSID enable/disable	X	X			X	X	X			X
	Signal Strength LED MAC	X	X			X	X	X			X
STP enable/disable	X	X		X	X	X	X		X	X	
Remote BSSID	X	X			X	X	X			X	
• Radio	Wireless Mode	X	X			X	X	X			X
	Tx Rate	X	X			X	X	X			X
	Channel No	X	X			X	X	X			X
	Tx Pwr Mode	X	X			X	X	X			X
	Propagation Distance	X	X			X	X	X			X
	RTS Threshold	X	X			X	X	X			X
	Remote BSSID			X					X		
• Encryption	No Encryption	X	X			X					X
	Triple-DES	X	X		X	X					X
	AES (128-/192-256-bit)	X	X		X	X					X
Service Settings											
• DHCP Server	Enable / Disable	X	X			X	X	X			X
	Starting / Ending IP address	X	X			X	X	X			X
• Subnet Roaming	Enable / Disable	X	X			X	X	X			X
	Coordinator Address	X	X		X	X	X	X	X		X
• SNMP agent	Enable/ Disable	X	X			X	X	X			X
	Community settings	X	X			X	X	X			X
	Secure User Configuration	X	X			X	X	X			X
	System Information	X	X			X	X	X			X
• Misc Service	Print Server: Enable/ Disable	X	X			X	X	X			X
User Management											
• List All Users		X		X	X	X					X
• Add New User			X								
• User Password Policy	Enable/Disable	X	X			X					X
	Policy setting	X	X			X					X
Monitoring/Reports											
• System Status	Security Mode	X					X				
	Current Encryption Mode	X					X				
	Bridging encryption mode	X					X				
	System Uptime	X					X				
	Total Usable memory	X					X				
	Free Memory	X					X				
	Current Processes	X					X				
	Other Information	X					X				

Categories	Features	Operator Roles										
		CryptoOfficer					Administrator					
		Show ²	Set ³	Add ⁴	Delete ⁵	Default Reset ⁶	Show ⁷	Set ⁸	Add ⁹	Delete ¹⁰	Default Reset ¹¹	
	Network interface status	X					X					
• Bridging Status	Status of Layer 2 bridge devices	X					X					
• Wireless Clients	MAC Address (manfr's name)	X					X					
	Received Signal Strength	X					X					
	TX rate	X					X					
• Adjacent AP List	AP MAC address	X					X					
	SSID	X					X					
	Channel	X					X					
	Signal	X					X					
	Noise	X					X					
	Type	X					X					
	Age	X					X					
	WEP	X					X					
• DHCP Client List	Client Hostname	X			X		X				X	
	IP Address	X			X		X				X	
	MAC Address (manfr's name)	X			X		X				X	
• System Log	Date/Time/Message	X			X		X				X	
• Web Access Log		X			X		X				X	
• Network Activities		X			X		X				X	
Auditing												
• Log		X					X	X				X
• Report Query		X					X					
• Configuration	Enable/Disable	X	X				X					X
	Selectable items	X	X				X					X
System Administration												
• System Upgrade	Firmware Upgrade	X	X				X					X
	Local Configuration Upgrade	X	X				X					X
	Remote Configuration Upgrade	X	X				X					X
• Factory Defaults		X										
• Remote Logging	Enable/Disable	X	X				X	X	X			X
	Settings	X	X				X	X	X			X
• Reboot		X					X					
• Utilities	Ping	X					X					
	Traceroute	X					X					

3.3.2. User Role Services

User Role: This role is assumed by the wireless client workstation that uses static or dynamic key AES or Triple-DES encryption to communicate wirelessly with the 525A-3/525V-3/525Ve-3/525Ve-4 product variants. Authentication is either performed

through entry of a static key by the user or an EAP-TLS authentication is performed, with the user providing a public key certificate. The static key (Triple-DES or AES key) is configured on the 525A-3/525V-3/525Ve-3/525Ve-4 product variants by the Crypto officer. The static key must be pre-shared between the 525A-3/525V-3/525Ve-3/525Ve-4 product variants and the User. The Gateway supports 128 Users (client workstations) if MAC address filtering is disabled. If MAC address filtering is enabled, only 60 Users are allowed.

The User role has the ability to send data to and through the 525A-3/525V-3/525Ve-3/525Ve-4 product variants. All data is sent in the form of 802.11i wireless packets. All wireless communication is encrypted using either Triple-DES or AES encryption (based upon the 525A-3/525V-3/525Ve-3/525Ve-4 product variants configuration). In bypass mode, plaintext packets can also be sent to the 525A-3/525V-3/525Ve-3/525Ve-4 product variants. The User role also employs 802.11i authentication schemes including 802.1X, EAP-TLS, and preshared key modes. Also, a Wireless Access Point (WAP) may act in the User role by communicating with the 525A-3/525V-3/525Ve-3/525Ve-4 product variants in bridging mode.

3.3.3. Security Server Role Services

Security Server Role: This role is assumed by the authentication server, which is a self-contained workstation connected to the 525A-3/525V-3/525Ve-3/525Ve-4 product variants over the Ethernet Uplink WAN port. The security server is employed for authentication of wireless clients and key management activities. The Security Server is used only during dynamic key exchange. The Security Server authenticates using a shared secret which is used as an HMAC-SHA1 key to sign messages sent to the 525A-3/525V-3/525Ve-3/525Ve-4 product variants during dynamic key exchange. The Security Server IP address and password are configured on the 525A-3/525V-3/525Ve-3/525Ve-4 product variants by the Crypto Officer. Only one Security Server is supported.

The Security Server performs following services:

- The EAP-TLS authentication from 3e-SS through the 3e-WAP to the 3e-010F Crypto Client
- Process dynamic key exchange after a successful authentication
- Perform a DH key exchange with the 525A-3/525V-3/525Ve-3/525Ve-4 product variants to negotiate an AES key
- Send Unicast key to the Gateway encrypted with the AES key negotiated using a DH key exchange

3.3.4. Unauthenticated Services

Unauthenticated services include the following:

Service	Description	Input	Output	Key/CSP
802.11a/b/g	802.11 wireless	802.11a/b/g	802.11a/b/g	None

(and variants, as well as WLAN management functions such as VLAN and MAC filtering are supported as described in the <i>User's Guide</i> section "Introduction")	traffic (used in both Approved encrypting modes and in bypass modes)	inputs and data	outputs and data	
NAT	Wired network service available only in gateway mode (used in both Approved encrypting modes and in bypass modes)	NAT inputs and data	NAT outputs and data	None
DHCP	Wired network service available only in gateway mode (used in both Approved encrypting modes and in bypass modes)	DHCP inputs and data	DHCP outputs and data	None

3.4. Cryptographic Algorithms

The 525A-3/525V-3/525Ve-3/525Ve-4 product variants supports the following FIPS-approved cryptographic algorithms:

- TDES (ECB, CBC modes; 192-bit keysize), cert #292
- AES (ECB mode; 128, 192, 256-bit keysizes), cert #238
- AES CCM (128-bit keysize), cert #1
- SHA-1, cert #278
- HMAC-SHA1, cert #13
- FIPS 186-2 (Appendix 3.1 and 3.1) PRNG, cert#22

The 525A-3/525V-3/525Ve-3/525Ve-4 product variants also supports the following non-FIPS cryptographic algorithms:

- Diffie Hellman (1024-bit modulus) allowed in FIPS mode for key agreement. This key establishment method provides 80-bits of security.
- RSA decrypt (PKCS#1 using a 1024-bit modulus) allowed in FIPS mode for key un-wrapping. This key establishment method provides 80-bits of security.
- RC4 (used in WEP/WPA)
- MD5 hashing (used in MS-CHAP for PPPoE and SNMP agent)
- DES CBC (non-compliant) (used in SNMP v3)
- AES CFB (non-compliant) (used in SNMP v3)

3.5. Cryptographic Keys and SRDIs

The 525A-3/525V-3/525Ve-3/525Ve-4 product variants contains the following security relevant data items:¹²

Non-Protocol Keys/CSPs						
Key/CSP	Type	Generation/ Input	Output	Storage	Zeroization	Use
Operator passwords	ASCII string	Input encrypted (using TLS session key)	Not output	Ciphertext in flash (SHA-1 hash)	Not zeroized	Used to authenticate CO and Admin role operators
Configuration file passphrase	HMAC key (ASCII string)	Input encrypted (using TLS session key)	Not output	Plaintext in RAM. It is put into temporary memory/auto variable/stack.	Zeroized when a configuration file is uploaded after it is used.	Used for downloaded configuration file message authentication
Firmware integrity check key	HMAC key (ASCII string)	Input encrypted (using TLS session key)	Not output	Plaintext in flash	Not zeroized.	Used for firmware load message authentication
SNMP packet authentication keys, username	HMAC key (ASCII string)	Input encrypted (using TLS session key)	Not output	Plaintext in flash	Zeroized when reset to factory settings.	Use for SNMP message authentication
RNG Keys/CSPs						
Key/CSP	Type	Generation/ Input	Output	Storage	Zeroization	Use
FIPS 186-2 seed	ASCII string (includes the value of a call to the standard C library time() function)	Not input	Not output	Plaintext in RAM	Zeroized every time a new random number is generated using the FIPS PRNG after it is used.	Used to initialize FIPS PRNG
FIPS 186-2 seed key	Symmetric	RNG	Not output	Plaintext in RAM	Zeroized every time a new random number is	Used to initialize FIPS PRNG

					generated using the FIPS PRNG after it is used.	
3eTI Static Protocol Keys/CSPs						
Key/CSP	Type	Generation/ Input	Output	Storage	Zeroization	Use
Static key	1. AES ECB (e/d; 128,192,256) 2. TDES (Triple-DES 192)	Input encrypted (using TLS session key)	Not output	Plaintext in flash	Zeroized when local antennae Approved encrypting mode either reconfigured or changed from 3eTI Static mode to any other local antennae Approved encrypting mode, to bypass mode. Zeroized when reset to factory settings.	Used to encrypt unicast, and broadcast/multicast traffic in support of static mode
3eTI DKE Protocol Keys/CSPs						
Key/CSP	Type	Generation/ Input	Output	Storage	Zeroization	Use
See EAP-TLS keys/CSPs	-	-	-	-	-	There are DKE-specific EAP-TLS keys/CSPs used to authenticate User operator to module
Dynamic unicast key	1. AES ECB (e/d; 128,192,256) 2. TDES (Triple-DES 192)	Not input (TLS master secret resulting from successful User EAP-TLS authentication in DKE mode)	Not output	Plaintext in RAM	Zeroized when 3eTI DKE session times out Note that it takes approximately five minutes for a DKE session to time out given the DKE protocol specification. When a timeout occurs after a session times out,	Used to encrypt unicast traffic in support of DKE

					zeroization is immediate.	
Dynamic broadcast key	1. AES ECB (e/d; 128,192,256) 2. TDES (Triple-DES 192)	RNG (it is only generated once, the first time a DKE client needs it, since all clients use same broadcast key)	Encrypted (using Dynamic unicast key)	Plaintext in RAM	Zeroized when local antennae Approved encrypting mode either reconfigured or changed from 3eTI DKE mode to any other local antennae Approved encrypting mode, to bypass mode.	Used to encrypt broadcast and multicast traffic in support of DKE. The same key is used for all DKE clients.
IEEE 802.11i Protocol PSK Keys/CSPs						
Key/CSP	Type	Generation/ Input	Output	Storage	Zeroization	Use
PSK mode passphrase	ASCII string	Input encrypted (using TLS session key)	Not output	Plaintext in flash	Zeroized when local antennae Approved encrypting mode either reconfigured or changed from IEEE 802.11i mode to any other local antennae Approved encrypting mode (including 802.11i EAP-TLS), to bypass mode. Zeroized when reset to factory settings.	Used to derive 802.11i PMK
IEEE 802.11i Protocol EAP-TLS Keys/CSPs						
Key/CSP	Type	Generation/ Input	Output	Storage	Zeroization	Use
See EAP-TLS keys/CSPs	-	-	-	-	-	There are 802.11i EAP-TLS-specific EAP-TLS keys/CSPs used to authenticate User operator to module
IEEE 802.11i Protocol Keys/CSPs (Common to PSK and EAP-TLS)						

Key/CSP	Type	Generation/ Input	Output	Storage	Zeroization	Use
PMK	<p>If 802.11i PSK, then derived from PSK mode passphrase: HMAC-SHA1 where passphrase is HMAC key and SSID is hashed.</p> <p>If 802.11i EAP-TLS, then secret key (TLS master secret)</p>	<p>If 802.11i PSK, then ASCII string is input encrypted (using TLS session key)</p> <p>If 802.11i EAP-TLS, then not input, instead derived (TLS master secret resulting from successful User EAP-TLS authentication in DKE mode)</p>	Not output	<p>If 802.11i PSK, then plaintext in flash</p> <p>For both 802.11i PSK and EAP-TLS, plaintext in RAM</p>	<p>Zeroized when local antennae Approved encrypting mode either reconfigured or changed from IEEE 802.11i mode to any other local antennae Approved encrypting mode (including from 802.11i PSK to 802.11i EAP-TLS, and 802.11i EAP-TLS to 802.11i PSK), to bypass mode.</p> <p>If 802.11i PSK, zeroized when reset to factory settings.</p>	802.11i PMK
PTK	AES (key derivation; 256)	Not input (derived from PMK)	Not output	Plaintext in RAM	When 802.11i session ends.	802.11i PTK
KCK	HMAC key (128 bits from PTK)	Not input (derived from PTK)	Not output	Plaintext in RAM	When 802.11i session ends.	802.11i KCK
KEK	AES ECB(e/d; 128)	Not input (derived from PTK)	Not output	Plaintext in RAM	When 802.11i session ends.	802.11i KEK
TK	AES CCM (e/d; 128)	Not input (derived from PTK)	Not output	Plaintext in RAM	When 802.11i session ends.	802.11i TK
TK (copy in driver)	AES CCM (e/d; 128)	Not input (derived from PTK)	Not output	Plaintext in RAM	When 802.11i session ends.	802.11i TK
GMK	AES (key derivation; 256)	Not input (RNG)	Not output	Plaintext in RAM	Zeroized when local antennae Approved encrypting mode either reconfigured or changed from IEEE 802.11i mode to any other local antennae	802.11i GMK

					Approved encrypting mode (including from 802.11i PSK to 802.11i EAP-TLS, and 802.11i EAP-TLS to 802.11i PSK), to bypass mode. When re-key period expires	
GTK	AES CCM (e/d; 128)	Not input (derived from GMK)	Output encrypted (using KEK)	Plaintext in RAM	Zeroized when local antennae Approved encrypting mode either reconfigured or changed from IEEE 802.11i mode to any other local antennae Approved encrypting mode (including from 802.11i PSK to 802.11i EAP-TLS, and 802.11i EAP-TLS to 802.11i PSK), to bypass mode. When re-key period expires	802.11i GTK
3eTI Security Server Keys/CSPs						
Key/CSP	Type	Generation/ Input	Output	Storage	Zeroization	Use
Security Server password	HMAC key (ASCII string)	Input encrypted (using TLS session key)	Not output	Plaintext in flash	Zeroized when local antennae Approved encrypting mode either reconfigured or changed from 3eTI DKE or IEEE 802.11i EAP-TLS mode to any other local	Authenticate module to Security Server in support of DKE and 802.11i EAP-TLS authentication

					<p>antennae Approved encrypting mode (including to 802.11i PSK), to bypass mode</p> <p>Zeroized when reset to factory settings.</p>	
Backend password	HMAC key (ASCII string)	Input encrypted (using TLS session key)	Not output	Plaintext in flash	<p>Zeroized when local antennae Approved encrypting mode either reconfigured or changed from 3eTI DKE or IEEE 802.11i EAP-TLS mode to any other local antennae Approved encrypting mode (including to 802.11i PSK), to bypass mode</p> <p>Zeroized when reset to factory settings.</p>	Authenticate messages between module and security server in support of 802.11i EAP-TLS
Backend key	AES ECB key (d;128)	Input encrypted (using TLS session key)	Not output	Plaintext in flash	<p>Zeroized when local antennae Approved encrypting mode either reconfigured or changed from 3eTI DKE or IEEE 802.11i EAP-TLS mode to any other local antennae Approved encrypting mode (including to 802.11i PSK), to bypass mode</p>	Decrypt TLS master secret returned to module by Security Server after successful User authentication in support of 802.11i EAP-TLS

					Zeroized when reset to factory settings.	
DH private exponent	Private DH key	RNG	Not output	Plaintext in RAM	Zeroized after decrypt TLS master secret returned from Security Server Zeroized if the DKE session times out.	Used in DH exchange performed after successful User EAP-TLS authentication in DKE mode
DH session key (a.k.a. AES post authentication key)	AES ECB key (d;128)	Not input (derived from DH exchange)	Not output	Plaintext in RAM	Zeroized when successfully authenticate 3eTI DKE client after decrypt TLS master secret returned from Security Server.	Decrypt TLS master secret returned to module by Security Server after successful User authentication in support of DKE EAP-TLS

3eTI Bridging Protocol Keys/CSPs

Key/CSP	Type	Generation/ Input	Output	Storage	Zeroization	Use
Bridging static key	AES ECB (e/d; 128,192,256) TDES (Triple-DES 192)	Input encrypted (using TLS session key)	Not output	Plaintext in flash	Zeroized when bridge antenna Approved encrypting mode either reconfigured or when changed from 3eTI bridging mode to any other bridging antenna mode. Zeroized when reset to factory settings.	Used to encrypt bridged traffic between two modules

RFC 2818 HTTPS Keys/CSPs

Key/CSP	Type	Generation/ Input	Output	Storage	Zeroization	Use
RSA private key	RSA (1024) (key wrapping; key establishment methodology)	Not input (installed at factory)	Not output	Plaintext in flash	Not zeroized.	Used to support CO and Admin HTTPS interfaces.

	provides 80-bits of encryption strength)					
TLS session key for encryption	Triple-DES (192)	Not input (derived)	Not output	Plaintext in RAM	Zeroized when a page of the web GUI is served after it is used.	TLS server write key

3.6. Self-Tests

The module performs the following self-tests:

Power-up self-tests:

- AES ECB - encrypt/decrypt KAT
- Triple-DES CBC – encrypt/decrypt KAT
- AES CCM KAT
- SHA-1 KAT
- HMAC-SHA-1 KAT
- FIPS 186-2 (Appendix 3.1, 3.3) RNG KAT
- DH pairwise consistency test (critical function)
- SHA-1 Integrity Test for firmware

Conditional self-tests:

- CRNGT for Approved PRNG
- CRNGT for non-Approved PRNG (Open SSL based RNG)
- Bypass Tests
- Firmware Load Test using HMAC-SHA-1

3.7. Secure Operation of the AirGuard Wireless Access Point

The following 525A-3/525V-3/525Ve-3/525Ve-4 product variants security rules must be followed by the operator in order to ensure secure operation:

1. Every operator (Crypto Officer or Administrator) has a user-id on the 525A-3/525V-3/525Ve-3/525Ve-4 product variants. No operator will violate trust by sharing his/her password associated with the user-id with any other operator or entity.
2. The Crypto Officer will not share any key, or SRDI used by the 525A-3/525V-3/525Ve-3/525Ve-4 product variants with any other operator or entity.
3. The Crypto Officer will not share any MAC address filtering information used by the 525A-3/525V-3/525Ve-3/525Ve-4 product variants with any other operator or entity.

4. The operators will explicitly logoff by closing all secure browser sessions established with the 525A-3/525V-3/525Ve-3/525Ve-4 product variants.
5. The operator will disable browser cookies and password storing mechanisms on the browser used for web configuration of the 525A-3/525V-3/525Ve-3/525Ve-4 product variants.
6. The Crypto officer is responsible for inspecting the tamper evident seals on a daily basis. A compromised tape reveals message “OPENED” with visible red dots. Other signs of tamper include wrinkles, tears and marks on or around the label.
7. The Crypto Officer should change the default password when configuring the 525A-3/525V-3/525Ve-3/525Ve-4 product variants for the first time. The default password should not be used.

Secure installation, configuration, and operation procedures are below.

3.7.1. Applying Tamper-Evident Seals (All Models)

The following section contains detailed instructions to the Crypto Officer concerning where and how to apply the tamper evident seals to the 525A-3/525V-3/525Ve-3/525Ve-4 product variants enclosure, in order to provide physical security for FIPS 140-2 level 2 requirements. Note the physical security rules are the same between the 525A-3 and the 525A-3MP.

A security seal is added from the back plate to the antenna plate. A second security seal is added from the front of the unit to the antenna plate, taking care not to cover the L.E.D. labeling. ½” length 440 Pan Head screws are used on each circular connector to secure them to the panel. Two 440 KEPS nuts and a nylon washer are added to the inside shaft and tightened together with washers facing each other approximately 1/32” from the connector panel. This prevents the screws from being removed and thus entry cannot be accomplished without removing the security labels.

Materials:

525A-3/525V-3/525Ve-3/525Ve-4 product variants – Quantity: 1
Seal, Tape, Tamper-evident – Quantity: 4
Isopropyl Alcohol Swab
3M Adhesive Remover (citrus or petroleum based solvent)

Installation – Tamper-evident tape

1. Locate on 525A-3/525V-3/525Ve-3/525Ve-4 product variants the placement locations of tamper-evident tape seals. (4 locations as shown in the figures above for the 525A-3/525V-3/525Ve-3/525Ve-4 product variants).
2. Thoroughly clean area where tamper-evident tape seal is to be applied with isopropyl alcohol swab. Area must be clean of all oils and foreign matter (dirt, grime, etc.)
3. Record tracking number from tamper-evident tape seal.

4. Apply seal to locations on the 525A-3/525V-3/525Ve-3/525Ve-4 product variants as shown in the figure above. It is important to ensure that the seal has equal contact area with both top and bottom housings.
5. After application of seals to the 525A-3/525V-3/525Ve-3/525Ve-4 product variants, apply pressure to verify that adequate adhesion has taken place.

Removal – Tamper-evident tape

1. Locate on 525A-3/525V-3/525Ve-3/525Ve-4 product variants locations of tamper-evident tape seals. (4 locations (two on each panel) as shown in the figure above for the 525A-3/525V-3/525Ve-3/525Ve-4 product variants)
2. Record tracking numbers from existing tamper-evident tape seal and verify physical condition as not tampered or destroyed after installation.
3. Cut tape along seam of 525A-3/525V-3/525Ve-3/525Ve-4 product variants to allow opening of enclosure.
4. Using 3M adhesive remover or equivalent, remove residual tamper-evident seal tape. (two locations as shown in the figure above for the 525A-3/525V-3/525Ve-3/525Ve-4 product variants)

The photos below show the physical interface of the 3e-525A-3 enclosure with tamper evident seals.



3e-525A-3 Side One – Upper Left



3e-525A-3 Side One – Lower Right



3e-525A-3 Side Two

The photos below show the physical interface of the 3e-525A-3 BASIC enclosure with tamper evident seals.



3e-525A-3 BASIC Side One



3e-525A-3 BASIC Side Two

The photos below show the physical interface of the 3e-525A-3MP enclosure with tamper evident seals.



3e-525A-3MP Side One



3e-525A-3MP Side Two

The figures below show the physical interface of the 3e-525V-3 enclosure with tamper evident seals.

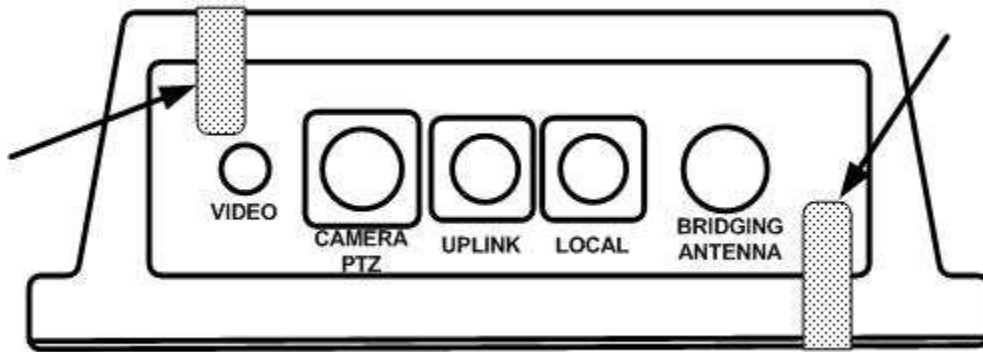

3e-525V-3 Side One

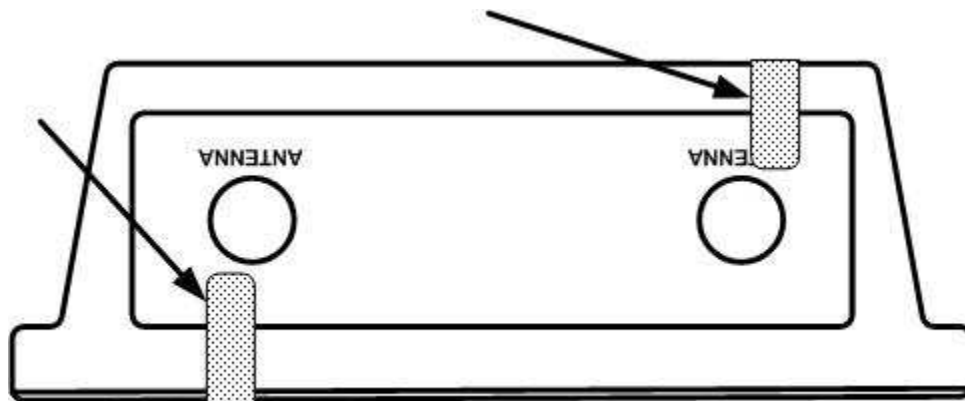

3e-525V-3 Side Two

The figures below show the physical interface of the 3e-525Ve-3 enclosure with tamper evident seals.

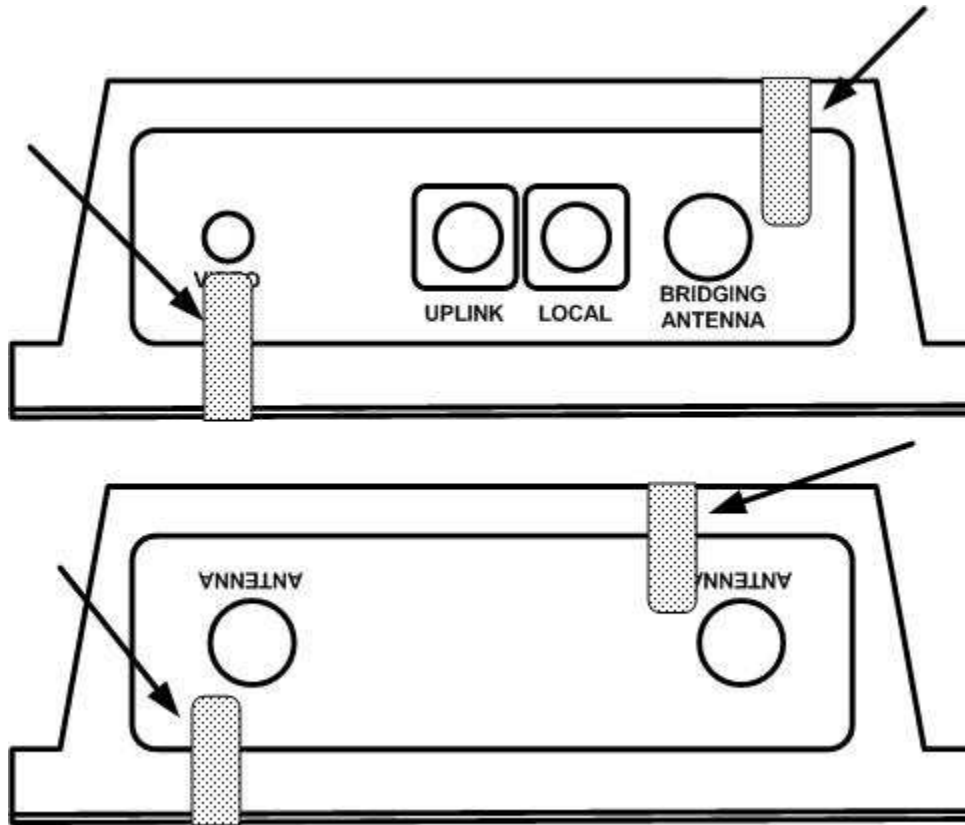

3e-525Ve-3 Sides One and Two

The figures below show the physical interface of the 3e-525Ve-4 enclosure with tamper evident seals.

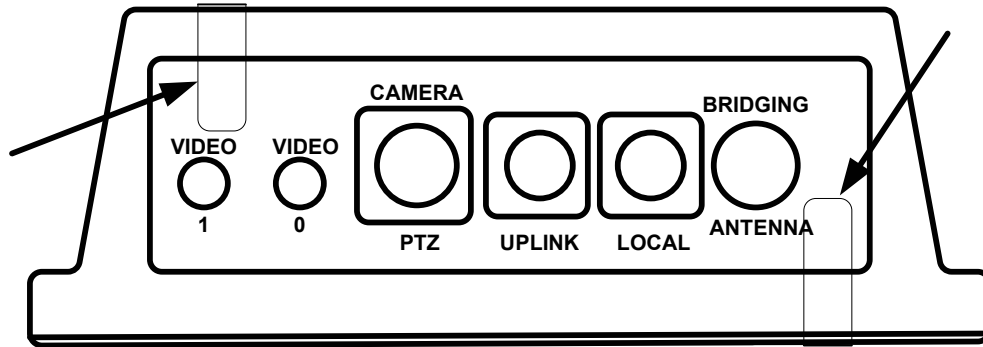

3e-525Ve-4 Side One

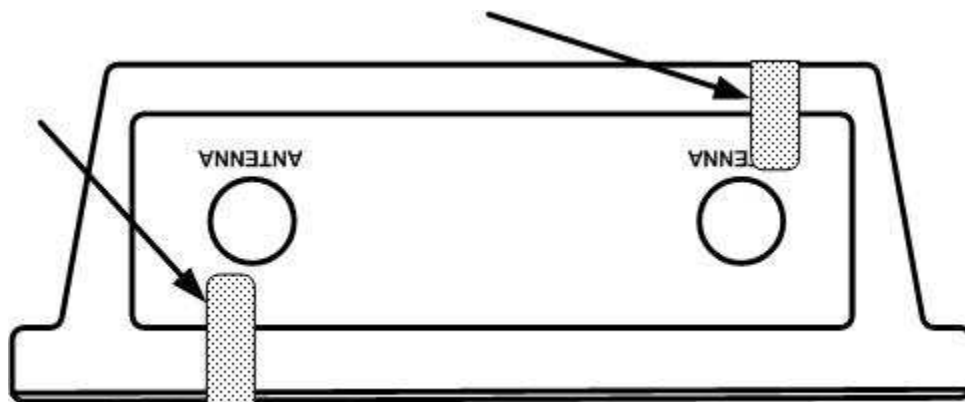

3e-525Ve-4 Side Two

3.7.2. Checking for Tamper Evidence

Tamper-evident seals should be checked for letters from the word “OPENED” left behind by seal residue when the seal is removed.

Tamper-evident seals should also be checked for nicks and scratches that make the metal case visible through the nicked or scratched seal.

Glossary

AP	Access Point
CO	Cryptographic Officer
DH	Diffie Hellman
DHCP	Dynamic Host Configuration Protocol
DMZ	De-Militarized Zone
IP	Internet Protocol
EAP	Extensible Authentication Protocol
FIPS	Federal Information Processing Standard
HTTPS	Secure Hyper Text Transport Protocol
LAN	Local Area Network
MAC	Medium Access Control
NAT	Network Address Translation
PRNG	Pseudo Random Number Generator
RSA	Rivest, Shamir, Adleman
SHA	Secure Hash Algorithm
SRDI	Security Relevant Data Item
SSID	Service Set Identifier
TLS	Transport Layer Security
WAN	Wide Area Network
WLAN	Wireless Local Area Network