

CHAPTER 18

VENTILATION

Blank Page

Table of Contents	Page
I. Introduction	18-1
II. Definitions	18-1
III. Underground Ventilation	18-2
A. Examining Mine Ventilation Plans and Maps	18-2
B. Inspecting Ventilation Systems	18-5
C. Air Quantity Surveys	18-5
IV. Surface Ventilation	18-18
A. General Ventilation	18-19
B. Local Exhaust Ventilation	18-20
Figure 18-1. Mine airflow with no ventilation controls	18-3
Figure 18-2. Mine airflow with ventilation controls	18-3
Figure 18-3. “Y” split with air quantities	18-4
Figure 18-4. Rectangle	18-6
Figure 18-5. Circle	18-6
Figure 18-6. Triangle	18-6
Figure 18-7. Parallelogram	18-6
Figure 18-8. Circular Roof	18-7
Figure 18-9. Slanted Roof	18-7
Figure 18-10. Rotating Vane Anemometer	18-8
Figure 18-11. Anemometer Traverse	18-9
Figure 18-12. Correction Factors	18-11
Figure 18-13. Split Traverse	18-12
Figure 18-14. Velometer	18-13
Figure 18-15. Velometer Traverse	18-14
Figure 18-16. Smoke Tube	18-14
Figure 18-17. Smoke Travel Time	18-16
Figure 18-18. Three different areas in entry	18-17
Figure 18-19. Range of Capture Velocities	18-22
Figure 18-20. Velocity Contours around a Hood as a Percentage of the Velocity at the Opening	18-23

Blank Page

October 2006

Chapter 18

VENTILATION

I. Introduction

Adequate workplace ventilation is an important and one of the most easily provided engineering methods for controlling airborne contaminants. A properly designed ventilation system can remove contaminants from the atmosphere or dilute the contaminants in the mine atmosphere to safe levels.

II. Definitions

Air Course - a pathway through which air travels to an area.

Brattice - a partition placed in an underground mine to control the flow of ventilation; typically made of canvas or plywood.

Capture Velocity - the air velocity necessary to capture and convey airborne contaminants in a ventilation system.

General Ventilation - ventilation system in a room, area, or building designed to control contaminant levels within the structure by dilution or removal.

Local Exhaust Ventilation - ventilation system designed to capture airborne contaminants at the source (a specific operation or process) before the airborne contaminants can escape into the general work environment.

Make-Up Air - clean air brought into a building or area from outside to replace air that has been exhausted by ventilation systems.

Short-Circuit - the path that air may naturally travel to an exhaust outlet, bypassing worker-occupied areas and creating an unventilated area.

Traverse - a method of measuring air velocity in an air passage, in which the instrument is moved across the cross-section of the air course or a portion of it in a steady, sweeping motion, rather than measuring the velocity at a single fixed point.

III. Underground Ventilation

This section provides guidance to metal and nonmetal mine inspection personnel regarding enforcement of the health-related mine ventilation standards delineated in 30 CFR 57 Subpart G - Ventilation. This section is not intended to provide guidance on safety-related ventilation standards, although some of the concepts and techniques may be applicable. The safety-related ventilation standards address two issues: the spread of fire and toxic combustion byproducts, and the control of methane gas in gassy mines. The fire standards are contained in 30 CFR 57 Subpart C - Fire Prevention and Control, and the methane standards are contained in 30 CFR 57 Subpart T - Safety Standards for Methane in Metal and Nonmetal Mines.

A. Examining Mine Ventilation Plans and Maps

Under 30 CFR §57.8520, a plan of an underground mine's ventilation system must be provided by the mine operator in written form. Revisions must be noted and updated at least annually. When examining mine ventilation plans and maps:

1. Check to ensure that required elements are included as required by §57.8520.
2. Follow the air course from intake(s), through the working area(s), to the return(s). Look for discrepancies between where the map or schematic **shows** air flows, and where the air would **actually** flow based on the location of ventilation control structures such as brattices, stoppings, regulators, and doors. Also check for inconsistencies in the indicated airflow rates.

Unless proper ventilation control structures are provided, you cannot assume air will travel along the pathways shown on the ventilation map or schematic.

Airflow will follow the path of least resistance. In mines where the air course cross sectional area is roughly uniform throughout the mine, air usually travels the shortest possible distance between two points. More precisely, more air travels the shorter paths, and less air travels the longer paths.

For example, consider the section of the ventilation map in Figure 18-1. The map shows air moving from 1 to 2 to 3 to 4, then turning to 8 to 12, and then turning to 11 to 10 to 9. However, without ventilation control structures to direct the airflow, much of the air would follow a shorter path. Instead, air would flow from 1 to 9. This path, called a **short-circuit**, is not indicated on the map; exists in reality and is the path of lesser resistance for air to travel.

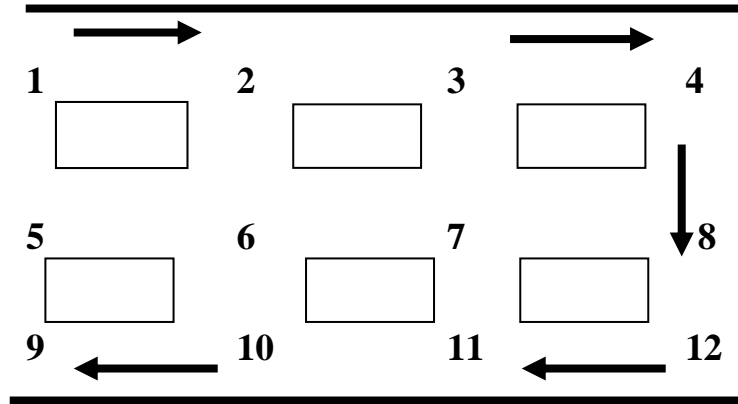

Figure 18-1. Mine airflow with no ventilation controls

The existence of a short-circuit is not a violation. However, a short-circuit could cause a violation of an air quality standard. For example, if the working face is at 4 or 8 or 12, and diesel equipment is being operated, overexposure to diesel exhaust gases might occur as a result of insufficient air reaching the face to dilute and carry away contaminants. Brattices or other suitable ventilation control structures between intersections 1 and 5, 2 and 6, 3 and 7, and 7 and 8 would force the fresh air into the face area, and prevent the short-circuit.

Recirculation is another problem caused by inadequate ventilation control structures. For example, consider the same section of the same ventilation map. This time, as shown in Figure 18-2, install brattices between 1 and 5, 2 and 6, 3 and 7, and 7 and 8, and insert a booster fan between 3 and 4 to increase air volume through the working areas at 4, 8, and 12.

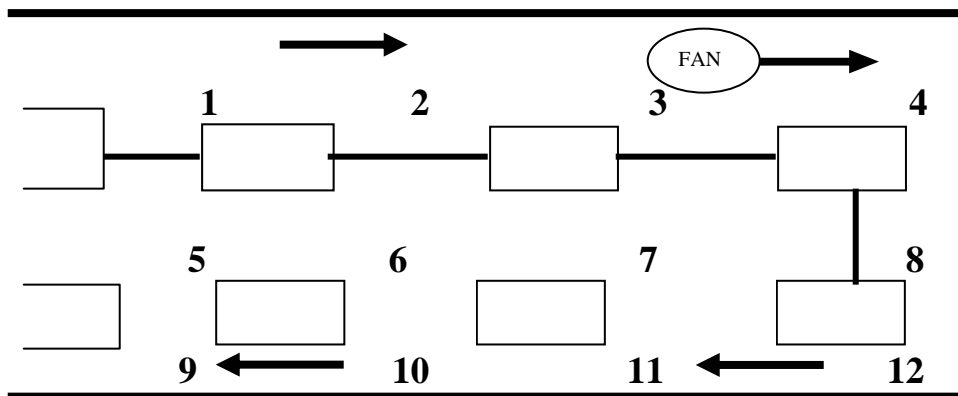

Figure 18-2. Mine airflow with ventilation controls

Although this fan will increase the airflow through the working areas as planned, it may have the unintended effect of creating a recirculation path through the brattices if there is leakage. This path would begin at the fan; travel through 4, 8, and 12, and back to the fan. Some fresh air will continue to enter this system and some contaminated air will be exhausted. But a portion of the air passing through the working areas is contaminated air that is being recirculated. Such a recirculation can cause air contaminant concentrations (dust, diesel exhaust, etc.) to become elevated, possibly resulting in overexposures of affected miners.

Another simple check when examining maps or schematics is to verify that indicated volumetric flows are consistent. For example, in this schematic, the flow rate (in cfm) on the left has to equal the sum of the flow rates on the right. Agreement between these numbers does not necessarily mean they are correct (they could all be wrong, but consistent with each other), but disagreement definitely indicates a problem.

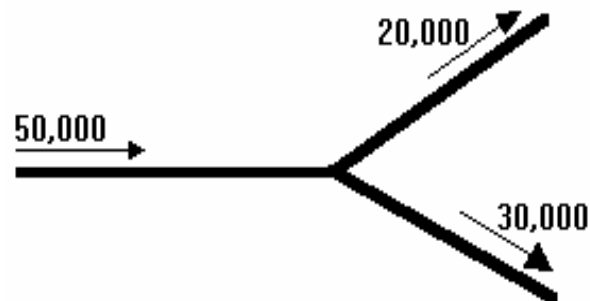

Figure 18-3. “Y” split with air quantities

The above examples are quite simple, and the ventilation system design flaws or map errors are obvious. Typically, however, airflow patterns are far more complex and the existence of short-circuits, recirculation paths, or other problems are very difficult to identify. In some cases, what appear to be errors may not be. For example, a recirculation path may actually be designed into a ventilation system as a cost saving strategy. Such systems may be acceptable according to 30 CFR 57.8529, as long as recirculation is minimal and provides fresh air that effectively sweeps the working places. If you find an air quality compliance problem (dust or contaminant gas overexposure) that you suspect could be caused or made worse by a complex ventilation problem (involving an auxiliary fan), contact your district office for assistance.

B. Inspecting Ventilation Systems

The surface and underground elements of the ventilation system must be thoroughly inspected to ensure compliance with applicable provisions of Subpart G - Ventilation. The elements of the system must also be consistent with the written ventilation plan or schematics, including items mentioned in Section I.A above. Note that ventilation plans need only be updated annually, so it is possible that recent changes in the ventilation system are not included in the plan.

C. Air Quantity Surveys**1. Airflow Direction and Quantity**

Spot checks of airflow direction and quantity may be necessary to verify agreement between the ventilation system and the ventilation plan. Airflow direction can usually be determined without special tools or instrumentation. However, an aspirator bulb-type smoke generator (smoke tube) can be used to enable flow visualization when necessary, such as when airflow is very low, or where winzes or raises intersect a level. Tricking a small amount of dust out of your hand can provide adequate airflow visualization to determine the direction of airflow.

To determine quantity flow, the cross sectional area of the air course and the air velocity must be measured. Air quantity flow is then calculated using the following formula:

$$Q = VA$$

where: Q = air quantity flow in cubic feet per minute (cfm)
V = air velocity in feet per minute (fpm)
A = cross sectional area of air course in square feet

2. Calculating Cross Sectional Area of the Air Course

Use the following formulas for calculating cross sectional areas (A):

- a. For a rectangle, $A = H \times W$:

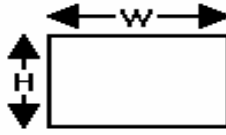

Figure 18-4. Rectangle

- b. For a circle, $A = D^2 \times 0.785$:

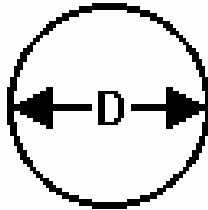

Figure 18-5. Circle

- c. For a triangle, $A = (\frac{1}{2}) \times H \times L$:

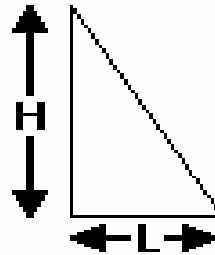

Figure 18-6. Triangle

- d. For a parallelogram, $A = H \times W$:

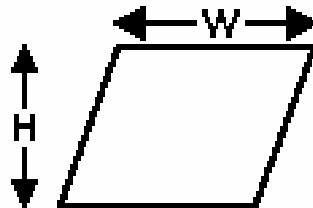

Figure 18-7. Parallelogram

For unusual shapes, divide the cross section into shapes for which area calculations can easily be made; then add the areas. For example:

- e. For the half-circle on top, $A_1 = (\frac{1}{2}) \times [D^2 \times 0.785]$
 For the rectangle, $A_2 = W \times H$
 For the triangle, $A_3 = (\frac{1}{2}) \times L \times H$

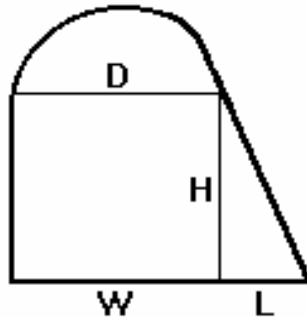

Figure 18-8. Circular Roof

- f. Another common shape is a rectangle with a slanted top:
 For the triangle on top, $A_1 = (\frac{1}{2}) \times W \times L$
 For the rectangle on the bottom, $A_2 = W \times H$
 Total Area = $A_1 + A_2$

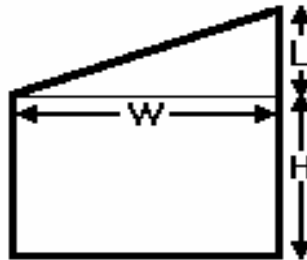

Figure 18-9. Slanted Roof

3. Determining Air Velocity

There are many techniques for measuring underground air velocity, but three are most common. These techniques utilize the rotating vane anemometer, swinging vane anemometer (velometer), and timed smoke clouds. The velometer is easiest to use, but the rotating vane anemometer provides much more accurate results. Therefore, a rotating vane anemometer should always be used when the air velocity is within its measurement range. Timed smoke clouds are used when an anemometer will not measure the velocity accurately.

- a. **Rotating Vane Anemometer** (see Figure 18-10) - The measuring range of this anemometer is indicated on the calibration data provided with the instrument. The typical range is 200 to 3000 feet per minute (fpm), but other models are also available with ranges of 50 to 5000 fpm, 200 to 10,000 fpm, etc. Do not use a rotating vane anemometer to measure air velocities below or above its indicated range. At air velocities below the indicated range, measurements are highly inaccurate and unreliable. At velocities above the indicated range, instrument damage can occur.



Figure 18-10. Rotating Vane Anemometer

The standard method for performing a velocity measurement using a rotating vane anemometer involves a “traverse” of the cross section to be measured. In a traverse, the anemometer is swept across the cross section of the air course, or portion of the air course, in a controlled, steady motion. It is important to traverse the cross section because air travels faster in the center of the air course than along the roof, walls, or floor. A single measurement at a fixed position in the air course would not be representative of the average velocity across the entire cross section.

In small air courses, the entire air course can be traversed or the air course can be divided in half and each half traversed separately (split traverse). In larger air courses, it is preferable to divide the air course in half. When performing split traverses, the velocities determined for both halves are averaged to determine the average air velocity for the air course as a whole. If the air course has a very large cross sectional area and a high roof, divide the air course into four equal quarters with the upper edge of the lower

quarters being at mid-wall height. Measure the two bottom quarters using the split traverse method. Figure 18-11 illustrates various traversing practices, depending on the dimensions of the air course cross section to be measured.

The anemometer can be attached to an extension handle when making a traverse. This allows the instrument to be held some distance away from the body to minimize air turbulence effects on the instrument reading. It is also helpful to use an extension handle when measurements must be made at locations with a high roof. If an extension handle is not available, the instrument should be held at arms length away from the body when traversing. When traversing, make sure the face of the anemometer is always perpendicular to the air flow and on the downstream side of the instrument.

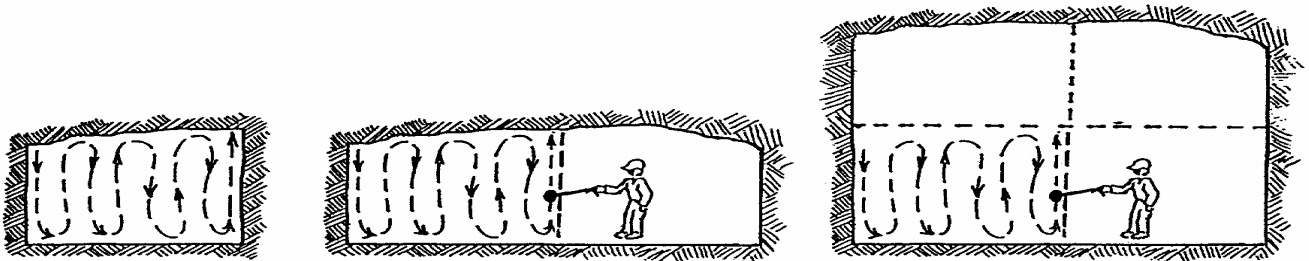

Figure 18-11. Anemometer Traverse

The traverse motion must be steady, and all parts of the area of the cross section must be covered equally, including corners, walls, roof, and floor (this may take some practice).

A suitable anemometer and a stopwatch are required to make a measurement. If a stopwatch is not available, a watch which measures in seconds is acceptable. It is easier to perform a measurement with two people - one to perform the traverse and one to operate the stopwatch - but it can be accomplished by one person. Normally, the timing period for a traverse is one minute (to make subsequent calculations easier), but any convenient time period is acceptable.

Measuring air velocity with a rotating vane anemometer involves the following:

- (1) Stop the vanes and “zero” the anemometer dial with the appropriate levers.
- (2) Position the instrument at a corner (wall/floor or wall/roof) where the velocity is slowest.
- (3) Allow the anemometer to reach full speed (a few seconds), and simultaneously start the stopwatch, release the vanes, and begin the traverse.
- (4) Simultaneously stop the stopwatch and the vanes at the end of the traverse.
- (5) Record the anemometer dial reading and the elapsed time from the stopwatch.
- (6) Repeat the above steps. If either traverse was not fully completed, do not use that measurement. Repeat the above steps until two good traverses are completed that agree to within 5 %. Again, this is easiest if the time period is constant at one minute. The resulting two readings would then be averaged.
- (7) If split traverses were performed, repeat the above steps for the other half of the air course.

The dial reading on a rotating vane anemometer reads in feet. Air velocity is obtained by dividing the anemometer reading by the time measured on the stopwatch. If the traverse is completed in exactly 1 minute, the dial reading is equal to the air velocity in feet per minute (fpm).

For example, if the final anemometer value is 655 feet, and the traverse was completed in exactly 1 minute, the velocity would be:

$$\frac{655 \text{ feet}}{1 \text{ minute}} = 655 \text{ feet/min} = 655 \text{ fpm}$$

If the same traverse was completed in 1 minute, 10 seconds, the same calculation would be performed to determine air velocity, but the time would first need to be converted to minutes, as follows:

1 minute, 10 seconds = 70 seconds

$$\frac{70 \text{ seconds}}{60 \text{ seconds/minute}} = 1.17 \text{ minutes}$$

$$\frac{655 \text{ feet}}{1.17 \text{ minutes}} = 560 \text{ feet/min} = 560 \text{ fpm}$$

The next step in determining velocity is the velocity correction. Initially, every anemometer is calibrated at the factory and provided with a velocity correction table. Subsequent calibrations provide a new correction table. Calculated velocities must be corrected using the correction factors provided on such tables. Listed correction factors are designated either “+” or “-.” Factors that are designated “+” are added to the measured velocity. Factors that are designated “-” are subtracted from the measured velocity.

For example, using the following table of correction factors, a velocity reading of 200 would be corrected to 215.

Serial No. 123456		Cal. Date 01-15-99	
Est. Vel.	Correction	Est. Vel.	Correction
50	+65	500	-15
100	+42	600	-22
150	+29	750	-36
200	+15	1000	-68
250	+8	1250	-79
300	+2	1500	-90
350	-3	1750	-113
400	-8	2000	-131
When sign is : + Add - Subtract			

Figure 18-12. Correction Factors

Note: This table is only an example and is not to be used for correcting actual velocity measurements. Every anemometer is individually calibrated, and you must use the calibration table provided with the anemometer.

If the measured velocity is not on the table, the correction factor must be “interpolated,” or estimated. For example, if the measured velocity is 340 fpm, the correction would be about -2. If the measured velocity is 1655 fpm, the correction would be about -104, and so on.

If a split traverse were performed, the two corrected velocities would be averaged to determine the overall corrected average air velocity for the entire air course cross section.

To help avoid errors and omissions in this process, it is helpful to create a table into which the various measurements, readings, and calculated values are inserted, as shown in this example of a split traverse and using the velocity correction factors from Figure 18-12:

	Left Half		Right Half	
	Traverse 1	Traverse 2	Traverse 1	Traverse 2
Time (sec)	60	60	60	60
Feet	760	745	780	750
Within 5 %	OK		OK	
Average	753 feet		765 feet	
Correction	-36		-37	
Corrected Average	717 fpm		728 fpm	
Overall Corrected Average	723 fpm			

Figure 18-13. Split Traverse

b. Swinging Vane Anemometer -Velometer

The velometer is a small, convenient, and easy-to-use instrument, but it has limited applications (see Figure 18-14). It is a direct-reading instrument that provides a roughly instantaneous measure of the air velocity wherever it is positioned. It can be used for air course velocity measurement, but since it is somewhat

cumbersome to traverse a cross section with a velometer, it is more commonly used to spot-check the velocity at a discrete location.



Figure 18-14. Velometer

Velometers are available with various scale ranges for velocity measurements and have accuracies of 5 % of full scale. For example, using a mid-range velometer set to the 0-1600 fpm scale, the accuracy would be $1600 \times 0.05 = 80$ fpm. Using this instrument, if the measured air velocity is 1350 fpm, the actual air velocity would be somewhere between 1270 fpm and 1430 fpm. However, as noted above, the overall accuracy of a velometer measurement in an air course is considerably lower than a rotating vane anemometer because of the errors inherent in sectional traversing.

To perform a traverse, the cross section of the air course needs to be divided into several sections having equal area. For example, the area might be divided into fourths, eighths, ninths, twelfths, sixteenths, etc. (See Figure 18-15).

The velometer is placed in the center of each section, and the velocity is read and recorded. The velocity through the cross section as a whole is the average of the velocities read for each section. The accuracy of the measurement improves as the number of sections increases, but the errors inherent in this method make it less accurate than a rotating vane anemometer.

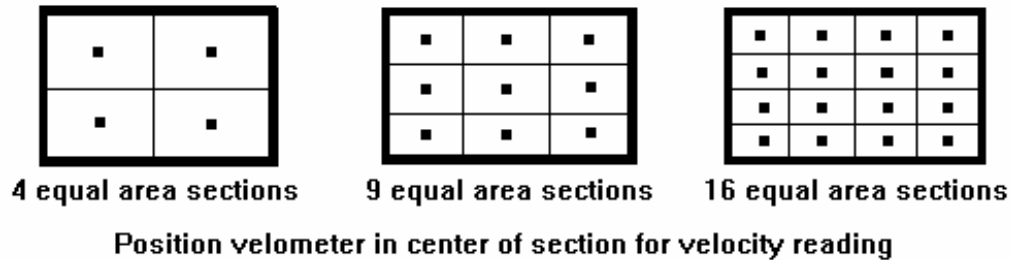

Figure 18-15. Velometer traverse

c. Timed Smoke Clouds

Use timed smoke clouds to measure velocities that are too low to measure accurately with an anemometer, usually below 100 fpm (see Figure 18-16).



Figure 18-16. Smoke Tube

- (1) **Measure the Distance** - Determine the distance over which the smoke cloud measurements are taken by observing how well a smoke cloud holds together. Pick a location that is as straight, uniform, and free of obstructions as possible. Use an aspirator bulb-type smoke generator (smoke tube) to create a smoke cloud, and watch carefully

how far the cloud travels before it breaks up. The smoke cloud begins to spread and dissipate as soon as it is released, but a discernible cloud should remain somewhat intact for a distance of at least 5 to 10 feet. Repeat this procedure enough times to produce reliable, repeatable results. Place upstream and downstream markers on the mine floor or wall corresponding to the smoke release point and the farthest point that the smoke clouds travel before breaking up. These markers are the reference points that are used for release of the smoke cloud and measurement of cloud travel time. The distance between them is critical and must equal the greatest distance the cloud holds together.

- (2) **Use a Stopwatch** - If available, use a stopwatch graduated in tenths or hundredths of a minute to simplify subsequent calculations. If the stopwatch is graduated in seconds, a velocity unit conversion from feet per second (fps) to feet per minute (fpm) is necessary. This also applies to a standard watch graduated in seconds, which may be used if a stopwatch is not available. To convert from feet per second (fps) to feet per minute (fpm), multiply by 60.

For example: $2.5 \text{ fps} \times 60 \text{ sec./min.} = 150 \text{ fpm}$

- (3) **Measure the Smoke Travel Time**
- (a) Two people are required, one at the upstream marker to release the smoke cloud and an observer/timer at the downstream marker who times the travel of the cloud.
 - (b) Divide the air course cross section into 4 quarters of roughly equal area.
 - (c) Simultaneously release the smoke cloud and start the stopwatch. Alternatively, release the smoke cloud upstream of the upstream marker and start the stopwatch when the cloud passes over the upstream marker. The smoke should be released roughly from the center point of one of the quarters.

- (d) Stop the stopwatch when the leading edge of the cloud passes the downstream marker, and record the time.
 - (e) Repeat steps (c) and (d) two more times for each of the four quarters in the air course cross section. If a smoke cloud dissipates too quickly for an accurate timing, don't use that measurement. Repeat steps (c) and (d) until three good timings are recorded for each quarter.
- (4) **Determine Average Travel Time** - Average all of the travel times recorded in step (c). It may be helpful to keep track of the measurements by preparing a table, as shown in Figure 18-17.

Quarter	Trial 1	Trial 2	Trial 3	Total Time (Seconds)
Upper Right	5	7	4	16
Lower Right	3	5	5	13
Upper Left	4	4	4	12
Lower Left	3	4	4	11
Total Time = 52 seconds Average Travel Time = $52 \div 12 = 4.3$ seconds				

Figure 18-17. Smoke Travel Time

- (5) **Determine Air Course Cross Sectional Area** - Determine the average cross sectional area of the air course by measuring the cross sections at the upstream and downstream markers and averaging the two.

If there are extreme variations in the dimensions of the air course over the measurement distance, an accurate determination of the cross sectional area requires measurements to be made at several locations. The cross sectional areas at each location are then averaged to obtain a reasonable approximation of the air course cross section.

In the following example (see Figure 18-18), the irregular areas shown encompass the distance (10 feet from end to end) for the smoke cloud measurement. The areas of the three rectangles would need to be determined. Add the three individual areas and divide by 3:

$$22 \times 35 = 770$$

$$14 \times 20 = 280$$

$$38 \times 15 = \underline{570}$$

$$1620$$

$$1620 \div 3 = 540 = \text{average cross sectional area}$$

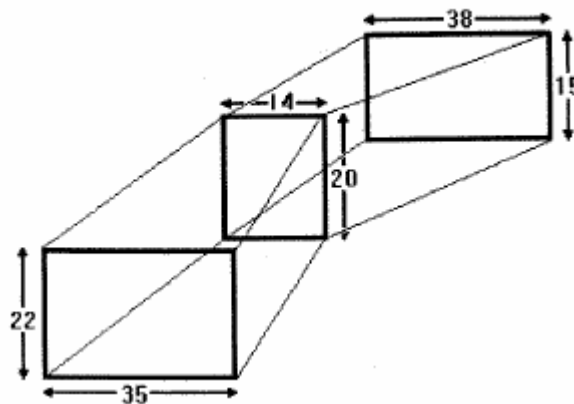

Figure 18-18. Three different areas in entry

- (6) **Compute and Adjust Air Velocity** - The average air velocity in the air course is determined by dividing the distance the smoke cloud traveled by the average travel time. Remember that a velocity unit's conversion from feet per second to feet per minute is necessary if the stopwatch (or watch) used for time measurements is graduated in seconds. For example, using a measurement distance of 10 feet and the times shown in the above table:

$$\text{Air velocity} = 10 \text{ feet} \div 4.3 \text{ seconds} = 2.3 \text{ feet/second}$$

$$2.3 \text{ feet/second} \times 60 \text{ seconds/minute} = 138 \text{ feet/minute}$$

When the leading edge of the smoke cloud is used to estimate cloud travel time, resulting determinations of air velocity are about 10 % too high. Thus, to improve accuracy, the velocity measurement must be adjusted by applying a method factor of 0.9. Using the above example, this factor would be applied as follows:

$$138 \text{ feet/minute} \times 0.9 = 124 \text{ feet/minute}$$

- (7) **Determine Airflow Rate** - Airflow rate in cubic feet per minute (cfm) is determined by multiplying the air velocity by the cross sectional area. For example, using the air velocity calculated in step (6) and the cross sectional area calculated in step (5):

$$\begin{aligned} \text{Airflow rate} &= 124 \text{ feet/minute} \times 540 \text{ feet}^2 \\ &= 67,000 \text{ feet}^3/\text{minute} = 67,000 \text{ cfm} \end{aligned}$$

IV. Surface Ventilation

Proper ventilation at surface installations helps provide a healthful atmospheric environment for mill attendants, maintenance mechanics, clean-up personnel, laborers, etc. Ventilation may be natural or mechanical. Natural ventilation is air movement by wind, temperature difference or other nonmechanical factors. Mechanical ventilation is caused by a fan or other air-moving device. Building ventilation systems fall into two categories: general ventilation and local ventilation. General ventilation refers to systems that provide air to ventilate entire rooms, large work areas, bays, or whole buildings. Local ventilation systems provide ventilation to specific pieces of equipment or work processes. Both general and local ventilation systems incorporate supply and exhaust elements, which must be compatible for the overall system to function properly. Mills, shops, and other surface buildings are often equipped with ventilation systems that combine general and local ventilation. Note that ventilation of certain underground facilities and processes, such as equipment maintenance and repair operations, may incorporate both general ventilation and local exhaust ventilation. Therefore, portions of this section may be applicable to underground mines as well as surface installations.

MSHA does not have specific performance criteria standards that address ventilation system ratings in surface buildings, but 30 CFR 56/57.14213 require that all welding operations be well ventilated. Proper operation of such systems is necessary to ensure compliance with specific health standards. For example, lack of appropriate ventilation in a mill could lead to respirable silica-bearing dust overexposures as determined in accordance with 30 CFR 56/57.5001. Similarly, inadequate ventilation in a shop could

result in overexposure to welding fumes, as per 30 CFR 56/57.5001. Therefore, an understanding of basic ventilation systems for buildings can help inspectors determine the likely cause of an overexposure condition. Further, as much as is feasible, control of airborne contaminants must be by prevention of contamination, removal by exhaust ventilation, or dilution with uncontaminated air (30 CFR 56/57.5005). The following sections describe ventilation systems for surface buildings and provide guidance to inspectors on identifying deficiencies.

A. General Ventilation

General industrial ventilation refers to the supply and exhaust of air to an area, room, or building. It is provided to dilute and carry away contaminants and to condition air for the comfort of occupants (usually heating and cooling). General ventilation systems may be large enough to accommodate an entire processing plant or small enough to service an operator's enclosed control room or booth.

There are numerous performance and design considerations that must be taken into account when planning and installing a general ventilation system, but these are usually beyond the scope of an inspector's enforcement activities. Inspectors should observe and document the general condition and operation of ventilation systems when conducting an inspection.

A major factor that influences whether mine management uses the general ventilation system is the outside temperature. Although these systems are usually designed for the dual purposes of controlling airborne contaminants and miner comfort, the miner comfort component sometimes prevails. In warm weather, the tendency would be to "crank up" the general ventilation system to draw in as much outside air as possible and to maintain a breeze across the work floor. Operating in this mode, the system would also be most effective in diluting and removing air contaminants.

In winter months, the tendency would be to "throttle down" the system to minimize heating expense and to reduce drafts of cold air on the work floor. In a large mill or shop, visible dust and haze in the air during a winter inspection might make it impossible to see from one end of the building to the other, whereas the air might be relatively free of visible contaminants during a summer inspection even though the work processes are roughly uniform throughout the year.

The presence of visible dust or haze does not necessarily indicate a hazardous condition. It should, however, alert the inspector to investigate further. When personal sampling is performed on employees working under these exposure

conditions, the operating status of the general ventilation system should be noted in the Health Field Notes. If an overexposure is documented, the absence of general ventilation or the failure to operate an existing system in the affected area should be included in the body of the citation.

Inspectors should also note whether adequate provision is made for make-up air. A general ventilation system in a mill or shop often consists of ventilators and fans in the roof or walls that draw contaminated air from inside and exhaust it outside. In the summer, make-up air usually enters the building through open doors and windows. In the winter, however, these doors and windows are normally closed. If no provision is made for make-up air, the general ventilation system will operate at only a fraction of its rated capacity because the fans on the roof will be starved for air.

Make-up air is usually in the form of a blowing supply system that draws outside air into the building. The blowing supply system may or may not include an air heater. If no air heater is provided, the blowing supply system may be shut down or operated at a very low rate in an effort to maintain a warmer temperature on the work floor. Even if an air heater is provided, the blowing supply system may be operated only on a limited basis to save on heating expenses.

Another approach to providing make-up air is to install intake ventilation grates or louvers in the walls, doors, etc. However, in cold weather, these openings may be shuttered or covered to prevent drafts. Under any of these conditions, even if the exhaust fans in the roof are turned on, the general ventilation system will function poorly because of a lack of sufficient make-up air. When conducting an inspection, obvious indications of insufficient make-up air are doors that fly open or slam shut accompanied by an inrush of air into the building.

Note: The location of make-up air inlets or portals is important to air quality in a mill or a mine. **The source of the make-up air should be located away from contaminated airstreams such as idling equipment exhausts or ventilation exhaust ports.**

B. Local Exhaust Ventilation

Local exhaust ventilation systems are designed to capture air contaminants (dust, gases, mists, fumes) that are produced by a specific operation or process before they can escape into the general work environment. The air drawn into a local exhaust system can be transported away from the work area for removal of contaminants or exhausted to the outside.

A local exhaust system consists of an entry hood, a transport duct, a fan, and an exhaust. As noted above, it may or may not also include a provision for contaminant removal such as a dust collector, filter, bag house or electrostatic precipitator. Systems may be portable, such as a self-contained cart-mounted welding fume eliminator, or they may be fixed installations in buildings. Fixed systems may consist of a single hood at one work location, or scores of hoods attached to thousands of feet of interconnected duct.

A properly designed local exhaust system performs its intended function with maximum effectiveness at minimum cost. From a compliance standpoint, a system need not be performing at maximum efficiency to be acceptable; it only needs to function at a level necessary to achieve compliance. Many systems are not constructed from an engineered design. They are assembled from available parts to do a job, and they are successful if workers are not overexposed.

As is the case with general ventilation systems, there are numerous considerations that must be taken into account when planning and installing a local exhaust ventilation system. These design considerations are generally beyond the scope of an inspector's enforcement activities. However, inspectors should observe and document the general condition and operation of such systems when conducting an inspection. For example, if sampling for welding fumes, note whether a welding fume ventilator is present in the shop, if it is in use and its condition.

The most critical element in a local exhaust ventilation system is the entry hood. The other downstream elements of the system may be designed and functioning properly, but if the entry hood is missing, is the wrong size or shape, or is improperly positioned, the overall system may function so inefficiently as to be almost worthless in capturing and removing contaminants. Therefore, when inspecting a local exhaust ventilation system, start with the entry hood.

The most important feature of an entry hood is the velocity of the inflowing air at various distances and in various directions from the hood. Air velocity is critical because contaminant capture and conveyance does not occur if the velocity is too low. The minimum velocity necessary to capture and convey the contaminant into the hood is called the **capture velocity**. Capture velocity varies depending on the contaminant being captured and the nature of the operation producing the contaminant. The table in Figure 18-19 shows typical ranges for recommended capture velocity for various contaminants and processes (source: American Conference of Governmental Industrial Hygienists - ACGIH, Industrial Ventilation Manual).

Condition of Dispersion of Contaminant	Example	Capture Velocity, fpm
Released with practically no velocity into quiet air	Evaporation from tanks, degreasing, etc.	50-100
Released at low velocity into moderately still air	Spray booths, intermittent container filling, low speed conveyor transfers, welding	100-200
Active generation into zone of rapid air motion	Spray painting in shallow booths, barrel filling, conveyor loading, crushers	200-500
Released at high initial velocity into zone at very rapid air motion	Grinding, abrasive blasting, tumbling	500-2000

Figure 18-19. Range of Capture Velocities

The goal of the local exhaust system is to create an inwardly directed air flow field sufficient to maintain, at a minimum, the necessary capture velocity at the farthest point at which contaminants may be present. By capturing and drawing contaminants into the system, they are prevented from escaping into the general workplace environment where they can be inhaled by workers. When examining an entry hood, use a suitable air velocity meter (rotating vane anemometer or velometer) to measure the inflowing air velocity at the locations where the contaminants are being generated and where they are propelled by the process. If an anemometer is not available, the capture velocity can be qualitatively spot-checked with a smoke tube. Air velocity drops rapidly as the distance from the hood opening increases. This emphasizes the importance of proper positioning of the hood relative to the process creating the contaminants. If the hood is too far away from the process, the local exhaust ventilation system is ineffective. Observe the diagram of air velocity contours in Figure 18-20.

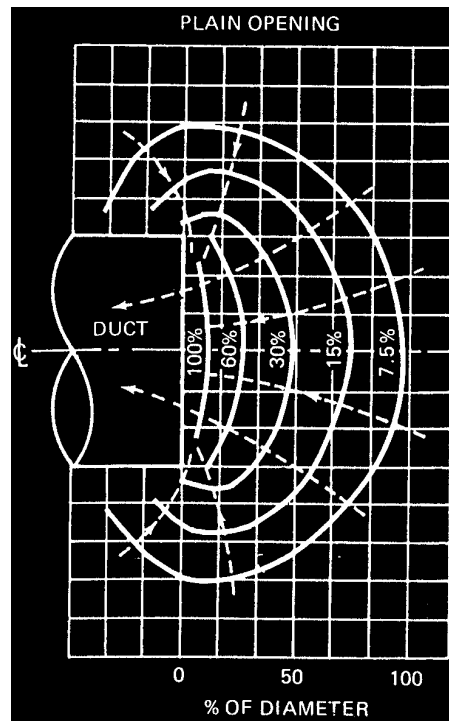

Figure 18-20. Velocity Contour around a Hood as a Percentage of the Velocity at the Opening

For example, using Figure 18-20, if the inflowing air velocity at the face of a 1-foot diameter circular hood is 500 fpm, the air velocity one foot directly in front of the hood opening is about 35 fpm.

Calculation: A distance of 1 foot is equal to 100% of the diameter. The closest contour line is at 7.5%. Extrapolating down to 7%, the velocity is:
 $7\% \times 500 \text{ fpm} = 35 \text{ fpm}$

Referring to the table of capture velocities in Figure 18-19, an air velocity of 35 fpm is not sufficient for even the least demanding application of local exhaust ventilation.

One way to improve contaminant capture is to fully or partially enclose the process control point with the hood. Enclosure hoods are often used on conveyor transfer points, feeders, and other similar applications.

If there is evidence of lack of capture efficiency despite adequate capture velocity, there may be random or intermittent interfering air currents that are

adversely affecting the system. Sources of such air currents could include a portable fan, open door or window, machinery motion (grinding wheel, belt conveyor), material motion (dumping, bag filling), movements of the operator, or thermal or convective room air currents.

The other elements of the local exhaust ventilation system that should be checked during an inspection are the duct, fan, contaminant removal equipment (if any) and exhaust. The duct should be checked for discontinuity, leaks, restrictions and plugs, any of which will reduce system efficiency or cause it to cease functioning completely. Ducts may be designed with enlarged, sharp nearly vertical bends to reduce abrasion and plugging. Numerous sharp bends or flexible “accordion” style segments may cause an excessive pressure drop across the system, and reduce transport velocity and performance. The fan should be checked for vibration, temperature, and dust accumulation. The contaminant removal equipment should be checked for leaks, restrictions, plugs or excessive loading. Filtered exhaust air could be checked for contaminant loading if the air is directed back into the work area. If possible, exhaust air is best directed outside.

Remember that a poorly designed or ineffective local exhaust or ventilation system is not necessarily a violative condition. However, if personal sampling documents an overexposure to any contaminant that should have been controlled by the system, the performance characteristics of that system are relevant to any resulting citation, and they should be thoroughly documented.