

CONSTRUCTION STANDARD SPECIFICATION
SECTION 16269
VARIABLE FREQUENCY CONTROLLERS

	<u>Page</u>
 <u>PART 1 - GENERAL</u>	
1.01 Summary	2
1.02 References.....	2
1.03 Definitions	3
1.04 Submittals	3
1.05 Quality Assurance.....	4
1.06 Storage	4
1.07 Warranty	4
1.08 Maintenance.....	4
 <u>PART 2 - PRODUCTS</u>	
2.01 Manufacturers	5
2.02 Manufactured Units	5
2.03 Components	10
2.04 Source Quality Control	10
2.05 Technical Support	11
2.06 Test And Inspection Equipment	11
 <u>PART 3 - EXECUTION</u>	
3.01 Examination	11
3.02 Installation	11
3.03 Field Quality Control	12

CONSTRUCTION STANDARD SPECIFICATION
SECTION 16269
VARIABLE FREQUENCY CONTROLLERS

PART 1 - GENERAL

1.01 SUMMARY

- A. Furnish and install a complete Variable Frequency Controller (VFC) system as described in this Section, and as detailed on Drawings. VFCs will be used to control speed of three-phase variable torque pump or fan alternating current (AC) induction motors.
- B. Related sections: refer to the following sections for related work:
1. Section 01330, "Submittal Procedures"
 2. Section 01700, "Closeout Procedures"
 3. Section 13943, "Facilities Control Systems"
 4. Section 15994, "Mechanical Systems Demonstrations"
 5. Section 16001, "Electrical Work"

1.02 REFERENCES

- A. Institute of Electrical and Electronics Engineers (IEEE)
- 519 Recommended Practices and Requirements for Harmonic Control in Electrical Power Systems
- B. National Electrical Manufacturers Association (NEMA)
- 250 Enclosures for Electrical Equipment (1000 Volts Maximum)
ICS 2-222 Overload Relay Class Designation
MG 1 Motors and Generators
- C. National Fire Protection Association (NFPA)
- 70 National Electrical Code (NEC)
- D. International Electro-technical Commission (IEC)
- 947-4-1 Low-voltage switchgear and Controlgear, Part 4-1: Contactors and Motor Starters

1.03 DEFINITIONS

FCS: Facilities Control System
FLN(P1): Floor Level Network (Protocol 1)
IGBT: Integrated gate bipolar transistor
PI: Proportional - Integral control action
PWM: Pulse-width modulated
SDR: Sandia Delegated Representative
VFC: Variable frequency controller

1.04 SUBMITTALS

- A. Equipment Submittals: Submit in accordance with conditions of Contract and Section 01330, "Submittal Procedures," except as noted herein.

- B. Product Data: For each type of VFC, provide dimensions; mounting arrangements; location for conduit entries; shipping and operating weights; and manufacturer's technical data on features, performance, electrical ratings, characteristics, and finishes.

- C. Shop Drawings: For each VFC:
 - 1. Include dimensioned plans, elevations, sections, and details, including required clearances and service space around equipment. Show tabulations of installed devices, equipment features, and ratings. Include the following:
 - a. Each installed unit's type and details.
 - b. Nameplate legends.
 - c. Short-circuit current ratings of integrated unit.

 - 2. Wiring Diagrams: Provide three (3) complete sets of VFC supplier's standard drawings showing schematics and wiring for each type of VFC.

- D. Operations and Maintenance Data: Provide three (3) copies of instruction books, operating manuals, comprehensive trouble shooting guide, spare parts list and special bulletins covering on-site storage.

- E. Manufacturer's field service report: Provide three (3) copies of the field test reports as specified in Part 3.

- F. Load-Current and Overload-Relay Heater List: Compile after motors have been installed and arrange to demonstrate that selection of heaters are sized for actual motor nameplate full-load currents.

- G. If VFC is derated, submit derating calculations.

1.05 QUALITY ASSURANCE

- A. Manufacturer's Qualifications: Minimum of five years experience in design and manufacture of VFCs of horsepower, range, and be knowledgeable in the latest technology specified on Contract Drawings and in this Section.
- B. Source Limitations: Obtain VFCs of a single type through one source from a single manufacturer.
- C. Electrical components, devices and accessories shall be labeled and listed as defined in NFPA 70, Article 100, for intended use.

1.06 STORAGE

- A. Store VFCs indoors in clean, dry space with uniform temperature to prevent condensation.
- B. Protect VFCs from exposure to dirt, fumes, water, corrosive substances, and physical damage.

1.07 WARRANTY

- A. Provide manufacturer's warranty certificate upon acceptance of VFC system that shall include the following as a minimum:
 - 1. If defect in supplied apparatus appears, or failure to comply with this Section is identified within period of two (2) years from date of manufacturer's certified start-up, not to exceed 30 months from shipment, response to repair or replacement of VFC shall be within a forty-eight (48) hour period.
 - 2. Contractor shall, without delay and at Contractor's own expense, correct defects or failure of compliance by repairing defective parts, supplying non-defective replacement parts, or correcting defective or deficient design by any other means recommended by VFC manufacturer and accepted by SDR.

1.08 MAINTENANCE

- A. Furnish extra materials described below that match products installed. Package with protective covering for storage, and identify with labels describing contents.

1. Furnish one spare fuse for every five installed, but not less than one set of three of each type and rating.
 2. Furnish two spare indicating lights of each type installed.
 3. Furnish one set of spare fans and filters for each size and type of filter installed in the VFC.
- B. Provide written certification from VFC supplier that spare printed circuit boards of each type utilized in VFC are readily available to SNL from VFC manufacturer within 24 hours of order. Describe each part and/or module and list stock number(s) of such parts.

PART 2 - PRODUCTS

2.01 MANUFACTURERS

- A. Subject to compliance with requirements, provide products by one of the following:
1. ABB Power Distribution
 2. Danfoss Graham

2.02 MANUFACTURED UNITS

- A. Description: The VFC shall convert the input AC main power to an adjustable frequency and voltage as defined in the following sections. The VFC shall use insulated gate bipolar transistors (IGBT) in the inverter section with a Pulse Width Modulated (PWM) output and arranged to provide variable speed of a NEMA MG 1, Design B, 3-phase, high efficiency induction motor by adjusting output voltage, current and frequency. The VFC shall be listed and labeled as a complete unit and shall include all accessories and requirements as described in this section.
- B. The VFC shall be rated as shown on drawings. As a minimum the full load output current of the drive shall be equal to the equivalent motor horsepower as listed by NEC.
- C. Unit Operating Requirements:
1. Input ac voltage tolerance of 200 volts AC ± 10 percent or 460 volts AC ± 10 percent, as specified in contract documents.
 2. Input frequency tolerance of 60 Hz, ± 2 Hz.
 3. Capable of driving full load, under the following conditions, without derating:
 - a. Ambient Temperature: 0 to 40 deg C
 - b. Humidity: Less than 90 percent (non-condensing)

c. Altitude: 5500 feet (1.7 km)

4. Minimum Efficiency: 96 percent at 60 Hz, full load
5. Minimum Displacement Primary-Side Power Factor: 96 percent
6. Overload Capability: 1.1 times the base load current for 60 seconds; 2.0 times the base load current for 3 seconds
7. Starting Torque: 100 percent of rated torque or as indicated
8. Speed Regulation: ± 1 percent
9. Isolated control interface to allow controller to follow control signal over an 11:1 speed range

D. Internal Adjustability Capabilities:

1. Minimum Speed: 0 to 100 percent of maximum rpm
2. Maximum Speed: 100 percent of maximum rpm
3. Acceleration: .1 to 1800 seconds
4. Deceleration: 1800 to .1 seconds
5. Current Limit: 50 to a minimum of 110 percent of maximum rating

E. Protection and Reliability Features: The VFC shall include the following:

1. The VFC including main breaker and bypass shall have an integrated withstand rating of no less than 100,000 amperes (symmetrical) and must be listed with UL or an equivalent test laboratory, unless noted otherwise in Contract documents.
2. Input transient protection by means of surge suppressors.
3. Upon power-up the VFC shall automatically test for valid operation of memory, loss of analog reference input, loss of communication, dynamic brake failure, DC to DC power supply, control power and the pre-charge circuit.
4. Under and over voltage trips, inverter over temperature, overload, and overcurrent trips.
5. Motor Overload Relay: Adjustable and capable of NEMA 250, Class 10 performance.
6. The VFC shall be capable of starting into a rotating load (forward or reverse) and accelerate or decelerate to set point without safety tripping or component damage (flying start).
7. The VFC shall be capable of DC injection braking at start to stop a reverse spinning motor prior to ramp.
8. The VFC shall be equipped with an automatic extended power ride-through circuit, which will utilize the inertia of the load to keep the drive powered. Typical control power ride-through for a fan load shall be a minimum of 200 milliseconds.
9. If the input reference power (4-20mA or 0-10V) is lost, this shall cause a warning to be issued and the user shall have the option of pre-selecting either (1) stopping and displaying the fault, (2) running at a programmable preset

- speed, (3) hold the VFC speed based on the last good reference received. The VFC shall be programmable to signal this condition via a keypad warning, relay output or over the serial communication link.
10. The VFC shall be capable of sensing a loss of load (broken belt or no water in pump) and signal the loss of load condition.
 11. Instantaneous line-to-line and line-to-ground overcurrent trips.
 12. Loss-of-phase protection.
 13. Reverse-phase protection.
 14. Short-circuit protection.
 15. Motor over temperature fault.
- F. Automatic Reset and Restart: To attempt three restarts after controller fault or on return of power after an interruption and before shutting down for manual reset or fault correction. Bi-directional auto-speed search shall be capable of starting into rotating loads spinning in either direction and returning motor to set speed in proper direction, without damage to controller, motor, or load.
- G. Input Line Conditioning: Provide input line conditioning equipment as required per Part 2.04.
- H. Status Lights: Door-mounted light indicators shall indicate: Power On, Run and Fault. The detailed information on the type of fault and other operating information on the VFC shall be annunciated on keypad display.
- I. Panel Mounted VFC Controller: A panel mounted VFC controller or electromechanical hand-off-auto switch shall allow for selection between “Hand”, “Auto” and “Off”. When “Hand” is selected motor speed shall be controlled via the panel mounted VFC controller. When “Auto” is selected motor speed shall be controlled via an external speed reference signal from either the FLN(P1) and/or a hardwired connection. The VFC shall incorporate “bumpless transfer” of speed reference when switching between “Hand” and “Auto” or between “Auto” and “Hand”. When “Off” is selected the VFC shall stop, regardless of prior control selection.
- J. Indicating Devices: Meters or digital readout devices and selector switch, mounted flush in controller door and connected to indicate the following controller parameters:
1. Output frequency (Hz)
 2. Motor speed (rpm)
 3. Motor status (running, stop, fault)
 4. Motor current (amperes)
 5. Motor torque (percent)
 6. Fault or alarming status (code)

7. PI feedback signal (percent)
 8. DC-link voltage (VDC)
 9. Set-point frequency (Hz)
 10. Motor output voltage (V)
- K. Control Signal Interface: Provide the VFC with the following unless otherwise specified on contract drawings:
1. Electrical Input Signal Interface: A minimum of 2 analog inputs 4-20 mA (24 VDC) and 4 programmable digital inputs.
 2. Remote Speed Control Signal Inputs: Shall be able to accept one or more of the following types of speed control input signals from the FCS system; which shall be specified in the contract documents:
 - a. 0 to 10 V dc
 - b. 4-20 mA (24 VDC)
 - c. 0 to 15 psig
 - d. Potentiometer using up/down digital inputs
 3. Additional Control Capabilities
 - a. Remote start-stop capabilities utilizing one of the above digital inputs.
 - b. PI control capabilities utilizing one of the analog inputs as the control variable, or the control variable monitored by the FLN(P1) connection.
 4. Output Signal Interface: A minimum of 1 analog output signal (0/4-20 mA), which can be programmed to any of the following:
 - a. Output frequency (Hz)
 - b. Output current (load)
 - c. Motor torque (percent)
 - d. Motor speed (rpm)
 - e. Set-point frequency (Hz)
 - f. Control variable value
- L. Communications: The VFC shall include an interface device that accepts control signals via SNL's Protocol 1 (P1) network communication connection to Siemens (Landis Division) Series 600 Modular Building Controller (MBC). Communication link shall meet the following requirements:
1. VFC shall have the ability to function on Siemens (Landis Division) system 600 P1 Network as a floor level network (FLN) device.
 2. As a minimum, the VFC shall be able to perform the following tasks via the P1 network:

- a. Monitor drive frequency output
 - b. Monitor drive speed
 - c. Monitor drive current
 - d. Monitor drive torque
 - e. Monitor drive power
 - f. Monitor drive temperature
 - g. Monitor drive kWh
 - h. Monitor drive run time
 - i. Monitor control variable
 - j. Control drive start/stop capabilities
 - k. Control drive speed determined by System 600 control strategy
3. Gateway-type protocol translation shall not be accepted.
- M. Input Power Disconnect: The VFC shall include a main power circuit breaker disconnecting device that opens all phases of incoming AC line. The disconnect shall provide positive shutdown of the input power to both VFC and bypass circuitry.
1. Disconnect shall be thermal magnetic, molded case circuit breaker.
 2. Mount circuit breaker inside controller enclosure, and include mounting bracket and through-the-door interlocking handle with provisions for padlocking.
 3. A mechanical interlock shall prevent an operator from opening VFC drive door when the disconnect is in the "ON" position. Another mechanical interlock shall prevent operator from placing the disconnect in the "ON" position while the VFC drive door is open.
- N. Electronic Bypass: When specified on Contract Drawings, the VFC shall include an electronic bypass that meets the following requirements:
1. Include circuitry necessary to safely transfer motor from VFC to power line, or from power line to VFC while motor is at zero speed.
 2. Include a three pole bypass contactor.
 3. Provide motor overload protection in both "Controller" and "Bypass" mode.
 4. A readily visible indicator shall be provided to indicate the tripped position of the overload.
 5. Refer to following schematic for typical VFC Bypass one-line diagram:

Typical VFC Bypass One-line Diagram

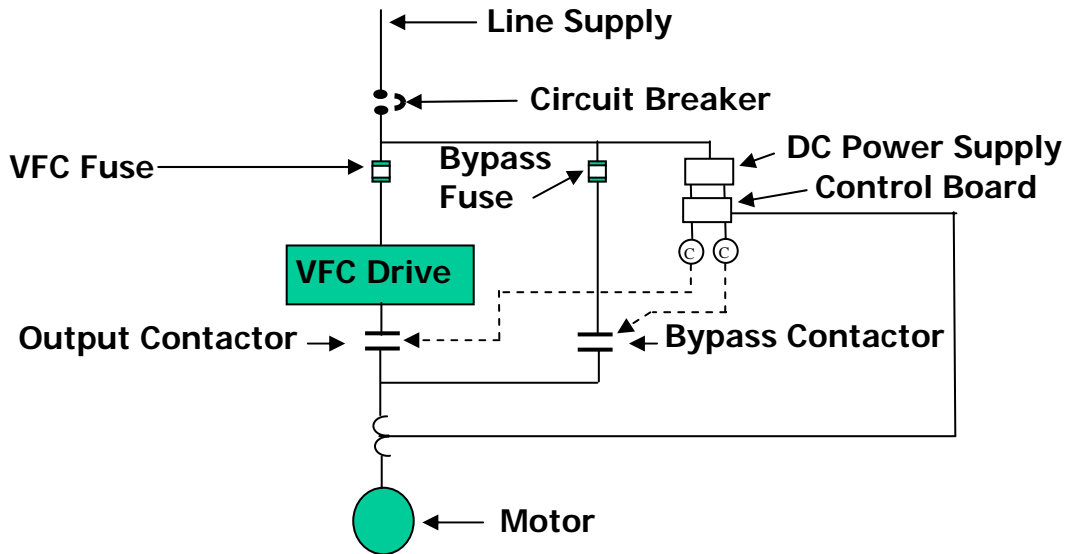

2.03 COMPONENTS

- A. Enclose the VFC in a Type 12 enclosure per NEMA 250, unless noted otherwise on Drawings.
- B. Louvers that are required for appropriate heat dissipation shall include air filters.
- C. Do not mount VFC in motor control center (MCC).
- D. Cooling fans shall be located and installed so that they are readily accessible and easily replaced.
- E. Finish: Manufacturer's standard paint applied to factory assembled and tested VFCs before shipping.

2.04 SOURCE QUALITY CONTROL

- A. Perform a harmonic analysis study in accordance with the latest version of IEEE 519 unless otherwise specified in contract documents.
- B. The harmonic distortion at the PCC shall be predicted through computer modeling of the distribution system and connected AC drives. SNL will provide power system data required to perform harmonic analysis study.

- C. Do not exceed harmonic voltage and current distortion limits at point of common coupling (PCC) for general system applications, as recommended and defined by IEEE 519, unless specified otherwise in contract drawings.
- D. If the calculations determine that the harmonic distortion levels are higher than the voltage and current specified, the drive manufacturer shall provide either line reactors, isolation transformers, multi-pulse drives or trap filters to meet the intent of IEEE 519.
- E. The harmonic analysis report shall be part of the submittal approval process.

2.05 TECHNICAL SUPPORT

- A. Provide written certification from VFC manufacturer stating the availability of technical support for minimum of five (5) years from start-up.
- B. Provide technical support on the following basis:
 - 1. Respond within 24 hours for diagnosis and repair the problem.

2.06 TEST AND INSPECTION EQUIPMENT

- A. Manufacturer shall inform SNL through their bid submittal, if VFC or VFC system provided requires any special tools or equipment to test, analyze or maintain system, and include additional price list for said equipment.

PART 3 - EXECUTION

3.01 EXAMINATION

- A. Examine areas and conditions under which VFCs are to be installed for compliance with requirements, installation tolerances, and other conditions affecting performance and provide SDR with written notification of conditions detrimental to proper completion of work.
- B. Proceed with installation only after unsatisfactory conditions have been corrected in manner acceptable to SDR.

3.02 INSTALLATION

- A. Anchor each VFC assembly arranged and sized according to manufacturer's written instructions. Attach by bolting.

- B. Coordinate mounting and anchoring of VFCs with drawing details.
- C. Install warning label on VFC indicating that load is subject to automatic restart upon power restoration.

3.03 FIELD QUALITY CONTROL

- A. Provide services: The Contractor shall engage a qualified VFC manufacturer's service engineer to perform the following:
 - 1. Test, checkout, and start up VFC system as required under "Field Quality Control" Article.
 - 2. Select features of each VFC to coordinate with ratings characteristics of supply circuit and motor; required control sequence; and duty cycle of motor, drive and load.
 - 3. Train Sandia National Laboratories' (SNL) personnel in proper operation and maintenance of VFC system.
 - 4. Contractor shall coordinate testing, checkout, start-up, and training functions with SNL Maintenance organization.
 - 5. Notify SDR a minimum of two weeks prior to scheduled test, checkout, and start-up.
- B. Do not energize any portion of VFC system without authorization from VFC manufacturer's representative and SDR.
- C. Demonstrate trouble-free, stable operation for the 0 to 100% speed range.
- D. Correct malfunctioning units on-site where possible and retest to demonstrate compliance; otherwise replace new units and retest.
- E. SNL will test VFC with a Dranetz power quality analyzer at point of common coupling, at no charge to Contractor, before and after installation.
 - 1. If harmonic voltage and current distortion exceed limits specified in Part 2, Contractor shall furnish and install, at no cost to SNL, devices necessary to reduce distortion to acceptable limits.
- F. VFC manufacturer's service engineer shall prepare final written documents of installation and inspection tests made in field, complete with meter readings and recordings, where applicable, and submit to SDR for approval. Data collected from these tests shall include:
 - 1. Incoming voltages from each phase leg to neutral, and from phase to phase
 - 2. External process signal and its source

3. Set-Up Parameters: Comply with SNL's written instructions
 - a. Acceleration time to full motor speed in seconds
 - b. Deceleration time from full motor speed in seconds
 - c. Second acceleration/deceleration as applicable
 - d. Maximum speed in hertz and RPM
 - e. Minimum speed in hertz and RPM
4. Operational Parameters
 - a. Line current for each phase at inverter at full load
 - b. Line current for each phase at bypass in bypass mode
 - c. Load current for each phase at full load
 - d. Load current for each phase at bypass in bypass mode
5. Ambient temperature during test
6. DC bus voltage
7. Frequency output at 100% reference signal
8. Name of person completing test and start-up procedure
9. Date start-up completed

END OF SECTION