



U.S. DEPARTMENT OF TRANSPORTATION
FEDERAL AVIATION ADMINISTRATION
National Policy

ORDER
8260.3B

Effective Date:
07/07/76

SUBJ: United States Standard for Terminal Instrument Procedures (TERPS)

This order prescribes standardized methods for use in designing instrument flight procedures. It is to be used by all personnel charged with the responsibility for the preparation, approval, and promulgation of terminal instrument procedures. Compliance with criteria contained herein is not a substitute for sound judgment and common sense. These criteria do not relieve procedures specialists and supervisory personnel from exercising initiative or taking appropriate action in recognizing both the capabilities and limitations of aircraft and navigational aid performance. These criteria are predicated on normal aircraft operations for considering obstacle clearance requirements.

These criteria have been officially adopted and contained as a joint publication between the Federal Aviation Administration (FAA), the United States Army (USA), the United States Navy (USN), the United States Air Force (USAF), and the United States Coast Guard (USCG).

For reference, below are the applicable official document numbers.

USA	TM 95-226
USAF	AFMAN 11-226(I)
USCG	CG 318
USN	OPNAV Inst 3722.16C
FAA	FAAO 8260.3B

Note: This is a CONSOLIDATED REPRINT including Changes 1 through 27.

RECORD OF CHANGES

8260.3B

CHANGE TO BASIC	SUPPLEMENTS			OPTIONAL USE	CHANGE TO BASIC	SUPPLEMENTS			OPTIONAL USE

FOREWORD

This publication prescribes standardized methods for use in designing instrument flight procedures. It is to be used by all personnel charged with the responsibility for the preparation, approval, and promulgation of terminal instrument procedures. Compliance with criteria contained herein is not a substitute for sound judgment and common sense. These criteria do not relieve procedures specialists and supervisory personnel from exercising initiative or taking appropriate action in recognizing both the capabilities and limitations of aircraft and navigational aid performance. These criteria are predicated on normal aircraft operations for considering obstacle clearance requirements.

The FAA recognizes that the increase in air traffic volume and technical improvements to air navigation systems require continuing emphasis on updating flight procedures standards.

This emphasis will be directed toward reassessment of three basic factors which contribute to overall system accuracy; e.g., ground element, airborne element, and flight technical (pilotage) element.

Analysis of individual ground system performance, using flight check information in the immediate vicinity of the facility used will be pursued in the development of standard values for assessing the dimensions of obstacle clearance areas.

Additionally, recognition will be given to airborne receiver performance to assure that credit is given to accepted improvements made in the state of the art. Concurrently, a review of airborne receiver performance is being conducted to determine whether existing standards need to be changed.

Pilotage error standards will be investigated to determine whether recent technological and operational advances indicate a change to the present standards is required.

Our overall objective is to assure that credit is allowed for improvements made in the ground and airborne environment and to assure that maximum safe use of airspace is realized.

With this in mind, an annual review of this publication by the signatory agencies, in coordination with other interested parties, will be conducted at the call of the FAA, Office of Flight Operations. More frequent reviews shall be conducted if required by a signatory agency. The FAA will provide approved changes to this publication by means of revision notices as required.

Recommendations concerning changes or additions should be provided to one of the following approving authorities as appropriate:

- * OFFICE OF FLIGHT OPERATIONS, FAA, Washington, D.C. 20591 (Civil Procedures) *
- DIRECTOR, U.S. Army Air Traffic Control Activity, Aeronautical Services Office (USAATCA-ASO), Cameron Station, Alexandria, Va. 22314
- * CHIEF OF NAVAL OPERATIONS, OP-554, Washington, D.C. 20350 *
- HEADQUARTERS, U.S. Air Force XOORF, Washington, D.C. 20330
- COMMANDANT, (G-OSR-2/73) U.S. Coast Guard, Washington, D.C. 20590

These criteria have been officially adopted by the Federal Aviation Administration, the United States Army, the United States Navy, the United States Air Force, and the United States Coast Guard. They are applicable at any location where the United States exercises jurisdiction over flight procedures in terminal areas. In addition, these criteria may be utilized for the development of special instrument approach procedures for use by U.S. military and air carriers at foreign airports.

BY ORDER OF THE SECRETARIES OF THE ARMY, NAVY, AIR FORCE, AND
TRANSPORTATION.

OFFICIAL:

J. C. PENNINGTON
Brigadier General, United States Army
The Adjutant General

BERNARD W. ROGERS
General, United States Army
Chief of Staff

OFFICIAL:

J. W. NANCE
Rear Admiral, U.S. Navy
Assistant Vice Chief of Naval
Operations/Director of Naval
Administration

OFFICIAL:

VAN L. CRAWFORD, Jr.
Colonel, USAF
Director of Administration Services

LEW ALLEN, Jr.
General, United States
Air Force
Chief of Staff

NORMAN C. VENZKE
Rear Admiral, United States
Coast Guard
Chief, Office of Operations

*

KENNETH S. HUNT
Director of Flight Operations
Federal Aviation Administration

*

DEPARTMENT OF DEFENSE DISTRIBUTION AND REQUISITION

U.S. Navy:

OPNAVINST 3722.16C

Distribution:

SNDL	A4A	CHIEF OF NAVAL MATERIEL
	A6	HEADQUARTERS, U.S. MARINE CORPS
	21A	FLEET COMMANDERS IN CHIEF
	22A	FLEET COMMANDERS
	24A	NAVAL AIR FORCE COMMANDERS
	26JJ	FLEET AREA CONTROL AND SURVEILLANCE FACILITY
	27G	SUPPORT FORCE (COMNAVSUPPPFORANTARCTICA Only)
	28A	CARRIER GROUP
	C3B	NAVAL PERSONNEL AT FAA ACTIVITIES
	FA5	AIR FACILITY LANT
	FA6	AIR STATION LANT
	FA7	STATION LANT (GUANTANAMO BAY, KEFLAVIK Only)
	FA24	BASE LANT
	FB6	AIR FACILITY PAC
	FB7	AIR STATION PAC
	FB10	STATION PAC (ADAK Only)
	FB34	FLEET ACTIVITIES
	FC4	AIR FACILITY NAVEUR
	FF62	CHIEF OF NAVAL RESERVE
	FKA1A	AIR SYSTEMS COMMAND HQ (AIR 5374)
	FKA6A1	AIR DEVELOPMENT CENTER
	FKM19	PUBLICATIONS AND PRINTING SERVICE
	FKR1A	AIR STATION NAVAIRSYSKOM
	FR3	AIR STATION CNAVRES
	FR4	AIR FACILITY CNAVRES
	FT1	CHIEF OF NAVAL EDUCATION AND TRAINING
	FT2	CHIEF OF NAVAL AIR TRAINING
	FT5	CHIEF OF NAVAL TECHNICAL TRAINING
	FT6	AIR STATION CNET
	FT13	AIR TECHNICAL TRAINING CENTER (MEMPHIS Only)
	V3	MARINE CORPS AIR BASES COMMANDERS
	V5	MARINE CORPS AIR STATION

*

OP's 09B34, 05, 52, 55, 554(35)

Stocked:

CO, NAVPUBFORMCEN
5801 Tabor Avenue
Phila., PA 19120

U.S. Army:

In accordance with DMA Catalog of Maps, Charts, and Related Products

Submit requisition to:

USAASO

Cameron Station

Alexandria, VA 22314

U.S. Air Force:

Submit requisition to:

DMAODS/DDCP

Washington, D.C. 20315

U.S. Coast Guard:

In accordance with COMDTNOTE 5600.

Submit requisition to:

DOT Warehouse

* ATTN: M-494.3

1725/35 15th Street NE

Washington, D.C. 20002

PUBLIC AVAILABILITY OF INFORMATION. This Handbook is in no way restricted, and the employee to whom it is issued will make it available for review by the public upon request. The public may purchase this document from:

Superintendent of Documents

U.S. Government Printing Office

Washington, D.C. 20402

TABLE OF CONTENTS

Page No.

Forward.....	iii-iv
DOD Distribution and Requisition	v-vi
Order Table of Contents	vii-xi
Volume 1 Table of Contents	i-xiv

VOLUME 1. GENERAL CRITERIA

CHAPTER 1

ADMINISTRATIVE

Section 1	Scope.....	1
Section 2	Eligibility, Approval, and Retention.....	1
Section 3	Responsibility and Jurisdiction	3
Section 4	Establishment.....	3
Section 5	Coordination.....	3
Section 6	Identification of Procedures.....	4
Section 7	Publication.....	5

CHAPTER 2

GENERAL CRITERIA

Section 1	Common Information.....	7
Section 2	En Route Operations.....	9
Section 3	Initial Approach	10
Section 4	Intermediate Approaches	16-2
Section 5	Final Approach	22
Section 6	Circling Approach.....	26
Section 7	Missed Approach	26-1
Section 8	Terminal Area Fixes	32
Section 9	Holding.....	36-3

CHAPTER 3

TAKEOFF AND LANDING MINIMUMS

Section 1	General Information	3-1
Section 2	Establishing Minimums Altitudes/Heights	3-7
Section 3	Visibility Minimums.....	3-14
Section 4	Alternate Minimums	3-24
Section 5	Takeoff Minimums.....	3-26

CHAPTER 4

ON-AIRPORT VOR (NO FAF)

Section 1	Low Altitude Procedures	45
Section 2	High Altitude Teardrop Penetration.....	47

TABLE OF CONTENTS (Continued)

	Page
CHAPTER 5. TACAN, VOR/DME, AND VOR WITH FAF	
Section 1 VOR with FAF.....	51
Section 2 TACAN and VOR/DME.....	56
CHAPTER 6 NDB PROCEDURES ON-AIRPORT FACILITY, NO FAF	
Section 1 Low Altitude Procedures	59
Section 2 High Altitude Penetration	62
CHAPTER 7 NDB WITH FAF	
Section 1 NDB with FAF	65
CHAPTER 8 VHF/UHF DF PROCEDURES	
Section 1 VHF/UHF DF Criteria	71
Section 2 Communications	73
Section 3 Minimums.....	73
CHAPTER 9 LOCALIZER AND LOCALIZER TYPE DIRECTIONAL AIDS (LDA).....	9-1
CHAPTER 10 RADAR PROCEDURES	
Section 1 Precision Approach Radar (PAR)	87
Section 2 PAR Final Approach.....	88
Section 3 PAR Missed Approach.....	89
Section 4 Airport Surveillance Radar (ASR)	93
Section 5 Simultaneous PAR Procedures.....	98
Section 6 Airborne Radar Procedures	98
CHAPTER 11. HELICOPTER PROCEDURES	
Section 1 Administrative.....	99
Section 2 General Criteria.....	99
Section 3 Takeoff and Landing Minimums.....	102
Section 5 TACAN, VOR/DME, and VOR with FAF	104
Section 6. On-Heliport NDB, No FAF.....	105
Section 7 NDB Procedures with FAF	106
Section 8 Reserved.....	106
Section 9 ILS Procedures	106
Section 10 Precision Approach Radar (PAR)	107
Section 11 Airport Surveillance Radar (ASR)	111
CHAPTER 12 RESERVED	

TABLE OF CONTENTS (Continued)

		Page
CHAPTER 13	RESERVED	
CHAPTER 14	SIMPLIFIED DIRECTIONAL FACILITIES (SDF) PROCEDURES	137
CHAPTER 15	AREA NAVIGATION (RNAV)	
Section 1	En Route Criteria.....	15-7
Section 2	Terminal Criteria.....	15-11
Section 3	Missed Approach	15-15
Section 4	Approach Minimums	15-20
CHAPTER 16	RESERVED	
CHAPTER 17	EN ROUTE CRITERIA	
Section 1	VHF Obstacle Clearance Area.....	173
Section 2	VHF Obstacle Clearance	180
Section 3.	Altitudes	182
Section 4.	Navigational Gaps.....	183
Section 5	Low Frequency Airways or Routes	185
Section 6.	Minimum Divergence Angles	186
APPENDIX 1	APPENDIX APPLICATION, GLOSSARY, ACRONYMS, AND ABBREVIATIONS (6 Pages)	A1-1
APPENDIX 2	PRECISION (6 Pages)	A2-1
APPENDIX 3	REFERENCES (2 Pages)	A3-1
APPENDIX 4	TABLE OF TAGENTS (5 Pages)	A4-1
APPENDIX 5	APPROACH LIGHTING SYSTEMS (6 Pages)	A5-1
APPENDIX 6	ALPABETICAL INDEX (22 Pages)	A6-1
VOLLUME 2. NONPRECISION APPROACH PROCEDURE (NPA) CONSTRUCTION		
RESERVED		

TABLE OF CONTENTS (Continued)

Page

**VOLUME 3. PRECISION APPROACH (PA) AND
APPROACH WITH VERTICAL GUIDANCE (APV)
APPROACH PROCEDURE CONSTRUCTION**

Volume 3 Table of Contents (6 Pages)..... i-vi

CHAPTER 1. GENERAL INFORMATION (8 Pages)..... 1-1

CHAPTER 2. GENERAL CRITERIA (18 Pages) 2-1

CHAPTER 3. PRECISION FINAL AND MISSED APPROACH SEGMENTS
(18 Pages) 3-1

CHAPTER 4. APPROACH WITH VERTICAL GUIDANCE (APV)
(14 Pages) 4-1

APPENDIX 1. RESERVED

APPENDIX 2. SIMULTANEOUS ILS PROCEDURES (6 Pages) A2-1

APPENDIX 3. CLOSE PARALLEL ILS/MLS APPROACHES (8 Pages) A3-1

APPENDIX 4. OBSTACLE ASSESSMENT SURFACE EVALUATION FOR
SIMULTANEOUS PARALLEL PRECISION OPERATIONS
(10 Pages) A4-1

APPENDIX 5. TCH/GPI/RPI CALCULATION (5 Pages)..... A5-1

VOLUME 4. DEPARTURE PROCEDURE CONSTRUCTION

Volume 4 Table of Contents (3 Pages)..... i-iii

CHAPTER 1. GENERAL CRITERIA (10 Pages) 1-1

CHAPTER 2. DIVERSE DEPARTURE (8 Pages) 2-1

CHAPTER 3. DEPARTURE ROUTES (18 Pages) 3-1

CHAPTER 4. VISUAL CLIMB OVER AIRPORT (VCOA) (6 Pages)..... 4-1

**VOLUME 5. HELICOPTER AND POWER LIFT
INSTRUMENT PROCEDURE CONSTRUCTION**

RESERVED

FAA ORDER

8260.3B

Army
Navy
Coast Guard
Air Force

TM 95-226
OPNAV Inst. 3722.16C
CG 318
AFMAN 11-226(I)

**UNITED STATES STANDARD
FOR
TERMINAL
INSTRUMENT
PROCEDURES
(TERPS)**



VOLUME 1

GENERAL CRITERIA

**U. S. DEPARTMENT OF TRANSPORTATION
FEDERAL AVIATION ADMINISTRATION**

THIS PAGE INTENTIONALLY LEFT BLANK

TABLE OF CONTENTS

		Page
Forward.....		iii-iv
DOD Distribution and Requisition		v-vi
Order Table of Contents.....		vii-x
Volume 1 Table of Contents		i-xvi
VOLUME 1. GENERAL CRITERIA		
CHAPTER 1	ADMINISTRATIVE	
Section 1	Scope.....	1
Section 2	Eligibility, Approval, and Retention.....	1
Section 3	Responsibility and Jurisdiction	3
Section 4	Establishment.....	3
Section 5	Coordination	3
Section 6	Identification of Procedures.....	4
Section 7	Publication	5
CHAPTER 2	GENERAL CRITERIA	
Section 1	Common Information.....	7
Section 2	En Route Operations	9
Section 3	Initial Approach	10
Section 4	Intermediate Approaches	16-2
Section 5	Final Approach.....	22
Section 6	Circling Approach.....	26
Section 7	Missed Approach	26-1
Section 8	Terminal Area Fixes	32
Section 9	Holding	36-3
CHAPTER 3	TAKEOFF AND LANDING MINIMUMS	
Section 1	General Information.....	3-1
Section 2	Establishing Minimum Altitudes/Heights.....	3-7
Section 3	Visibility Minimums.....	3-14
Section 4	Alternate Minimums	3-27
Section 5	Takeoff Minimums	3-28
CHAPTER 4	ON-AIRPORT VOR (NO FAF)	
Section 1	Low Altitude Procedures	45
Section 2	High Altitude Teardrop Penetration.....	47
CHAPTER 5	TACAN, VOR/DME, AND VOR WITH FAF	
Section 1	VOR with FAF.....	51
Section 2	TACAN and VOR/DME.....	56

TABLE OF CONTENTS (Continued)

	Page
CHAPTER 6	NDB PROCEDURES ON-AIRPORT FACILITY, NO FAF
Section 1	Low Altitude Procedures59
Section 2	High Altitude Penetration62
CHAPTER 7	NDB WITH FAF
Section 1	NDB with FAF.....65
CHAPTER 8	VHF/UHF DF PROCEDURES
Section 1	VHF/UHF DF Criteria71
Section 2	Communications73
Section 3	Minimums73
CHAPTER 9	LOCALIZER AND LOCALIZER TYPE DIRECTIONAL AIDS (LDA)..... 9-1
CHAPTER 10	RADAR PROCEDURES
Section 1	Precision Approach Radar (PAR)87
Section 2	PAR Final Approach.....88
Section 3	PAR Missed Approach89
Section 4	Airport Surveillance Radar (ASR).....93
Section 5	Simultaneous PAR Procedures98
Section 6	Airborne Radar Procedures.....98
CHAPTER 11	HELICOPTER PROCEDURES
Section 1	Administrative.....99
Section 2	General Criteria.....99
Section 3	Takeoff and Landing Minimums 102
Section 5	TACAN, VOR/DME, and VOR with FAF..... 104
Section 6	On-Heliport NDB, No FAF 105
Section 7	NDB Procedures with FAF..... 106
Section 8	Reserved..... 106
Section 9	ILS Procedures..... 106
Section 10	Precision Approach Radar (PAR)..... 107
Section 11	Airport Surveillance Radar (ASR)..... 111
CHAPTER 12	RESERVED

VOLUME 1. TABLE OF CONTENTS

GENERAL CRITERIA

		Page
CHAPTER 1	ADMINISTRATIVE	
Section 1	Scope.....	1
1.	Purpose.....	1
2.	Distribution	1
3.	Cancellation	1
4.	Existing Procedures	1
5.	Types of Procedures.....	1
6.	Word Meanings.....	1
7.-119.	Reserved.....	1
Section 2	Eligibility, Approval, and Retention.....	1
120.	Eligibility	1
121.	Requests for Procedures.....	2
122.	Approval	2
123.	Retention and Cancellation.....	2
124.-129.	Reserved.....	2
Section 3	Responsibility and Jurisdiction.....	3
130.	Responsibility	3
131.	Jurisdiction.....	3
132.-139.	Reserved.....	3
Section 4	Establishment.....	3
140.	Formulation.....	3
141.	Nonstandard Procedures	3
142.	Changes.....	3
143.-149.	Reserved.....	3
Section 5	Coordination	3
150.	Coordination	3
151.	Coordination Conflicts.....	4
152.-159.	Reserved.....	4

VOLUME 1. TABLE OF CONTENTS (Continued)

		Page
Section 6	Identification of Procedures.....	4
160.	Identification of Procedures.....	4
161.	Straight-in Procedure Identification.....	4
162.	Circling Procedure Identification.....	5
163.	Differentiation.....	5
164.-169.	Reserved.....	5
Section 7	Publication	5
170.	Submission.....	5
171.	Issuance.....	5
172.	Effective Date	5
173.	Mathematics Convention	6
174.	Information Update.....	7
175.-199.	Reserved.....	7
CHAPTER 2	GENERAL CRITERIA	
200.	Scope.....	7
Section 1	Common Information.....	7
201.	TERPS.....	7
202.	Level OCS.....	7
203.	Sloping Obstacle Clearance Surfaces (OCS).....	7
204.-209.	Reserved.....	7-2
210.	Units of Measurement.....	7-2
211.	Positive Course Guidance (PCG).....	7-3
212.	Approach Categories (CAT).....	7-3
213.	Approach Category Application	7-3
214.	Procedure Construction.....	7-3
215.	Controlling Obstacle(s).....	9
216.-219.	Reserved.....	9
Section 2	En Route Operations.....	9
220.	Feeder Routes.....	9
221.	Minimum Safe/Sector Altitudes (MSA)	9
222.-229.	Reserved.....	10

VOLUME 1. TABLE OF CONTENTS (Continued)

		Page
Section 3	Initial Approach	10
230.	Initial Approach Segment	10
231.	Altitude Selection.....	10
232.	Initial Approach Segments Based on Straight Courses and Arcs with PCG	10
233.	Initial Approach Segment Based on DR.....	11
234.	Initial Approach Segment Based on a Procedure Turn (T).....	12-1
235.	Initial Approach Based on High Altitude Teardrop Penetration	13
236.	Initial Approach course Reversal using Non-collocated Facilities and a Turn of 120° or Greater to Intercept the Inbound Course.....	15
237.-239.	Reserved.....	16-2
Section 4	Intermediate Approaches	16-2
240.	Intermediate Approach Segment.....	16-2
241.	Altitude Selection.....	16-2
242.	Intermediate Approach Segment Based on Straight Courses	17
243.	Intermediate Approach Segment Based on an Arc	18
244.	Intermediate Approach Segment within a PT	18
245.-249.	Reserved.....	22
Section 5	Final Approach.....	22
250.	Final Approach Segment.....	22
251.	Visual Portion of the Final Approach Segment	22
252.	Descent Angle/Gradient.....	23
253.	Visual Descent Point (VDP).....	25
254.-259.	Reserved.....	26
Section 6	Circling Approach.....	26
260.	Circling Approach Area.....	26
261.	Circling Approach Area not Considered for Obstacle Clearance.....	26-1
262.-269.	Reserved.....	26-1

VOLUME 1. TABLE OF CONTENTS (Continued)

	Page
Section 7	Missed Approach26-1
270.	Missed Approach Segment26-1
271.	Missed Approach Alignment27
272.	MAP27
273.	Straight Missed Approach Area27
274.	Straight Missed Approach Obstacle Clearance27
275.	Turning Missed Approach Area28
276.	Turning Missed Approach Obstacle Clearance29
277.	Combination Straight and Turning Missed Approach Area30
278.	End of Missed Approach32
279.	Reserved32
Section 8	Terminal Area Fixes32
280.	General32
281.	Fixes Formed by Intersection32
282.	Course/Distance Fixes32
283.	Fixes Formed by Radar34
284.	Fix Displacement Area34
285.	Intersection Fix Displacement Factors34
286.	Other Fix Displacement Factors34
287.	Satisfactory Fixes35
288.	Using Fixes for Descent36-1
289.	Obstacles Close to a Final Approach or Stepdown Fix36-2
Section 9	Holding36-3
290.	Holding Patterns36-3
291.	Alignment36-3
292.	Area36-3
293.	Obstacle Clearance36-3
294.-299.	Reserved36-4
CHAPTER 3	TAKEOFF AND LANDING MINIMUMS
3.0	Application3-1
3.1	Establishment3-1
3.1.1	Publication3-1
3.1.2	Runway Visual Range (RVR)3-2
3.1.3	Approach Lighting Systems3-2
3.2	Decision Altitude (DA) or Decision Height (DH)3-7

VOLUME 1. TABLE OF CONTENTS (Continued)

	Page
3.2.1	Minimum Descent Altitude (MDA).....3-7
3.2.2	Adjustments to Minimum Altitudes/Heights.....3-8
3.3	Visibility Minimums.....3-14
3.3.1	Authorization.....3-14
3.3.2	Establishing Straight-In Visibility Minimums.....3-14
3.3.3	Establishing Circling Visibility Minimums.....3-22
3.4	Establishing Alternate Minimums (Other than Standard).....3-24
3.4.1	Authorization.....3-24
3.4.2	Establishing Alternate Minimums.....3-24
3.5	Civil Standard Takeoff Minimums.....3-26
CHAPTER 4	ON-AIRPORT VOR (NO FAF)
400.	General.....45
401.-409.	Reserved.....45
Section 1	Low Altitude Procedures.....45
410.	Feeder Routes.....45
411.	Initial Approach Segment.....45
412.	Intermediate Segment.....45
413.	Final Approach Segment.....45
414.	Missed Approach Segment.....47
415.-419.	Reserved.....47
Section 2	High Altitude Teardrop Penetration.....47
420.	Feeder Routes.....47
421.	Initial Approach Segment (IAF).....47
422.	Intermediate Segment.....47
423.	Final Approach Segment.....47
424.	Missed Approach Segment.....49
425.-499.	Reserved.....49
CHAPTER 5	TACAN, VOR/DME, AND VOR WITH FAF
500.	General.....51
501.-509.	Reserved.....51

VOLUME 1. TABLE OF CONTENTS (Continued)

		Page
Section 1	VOR with FAF.....	51
510.	Feeder Routes.....	51
511.	Initial Approach Segment	51
512.	Intermediate Approach Segment.....	51
513.	Final Approach Segment.....	51
514.	Missed Approach Segment	55
515.-519.	Reserved.....	56
Section 2	TACAN and VOR/DME.....	56
520.	Feeder Routes.....	56
521.	Initial Segment	56
522.	Intermediate Segment	56
523.	Final Approach Segment.....	56
524.	Missed Approach Segment	57
525.-599.	Reserved.....	57
CHAPTER 6	NDB PROCEDURES ON-AIRPORT FACILITY, NO FAF	
600.	General.....	59
601.-609.	Reserved.....	59
Section 1	Low Altitude Procedures	59
610.	Feeder Routes.....	59
611.	Initial Approach segment.....	59
612.	Intermediate Segment	59
613.	Final Approach Segment.....	59
614.	Missed Approach Segment	61
615.-619.	Reserved.....	61
Section 2	High Altitude Teardrop Penetration.....	62
620.	Feeder Routes.....	62
621.	Initial Approach Segment	62
622.	Intermediate Segment	62
623.	Final Approach Segment.....	62
624.	Missed Approach Segment	62
625.-699.	Reserved.....	62

VOLUME 1. TABLE OF CONTENTS (Continued)

		Page
CHAPTER 7	NDB WITH FAF	
700.	General.....	65
701.-709.	Reserved.....	65
Section 1	NDB with FAF.....	65
710.	Feeder Routes.....	65
711.	Initial Approach Segment	65
712.	Intermediate Approach Segment.....	65
713.	Final Approach Segment.....	65
714.	Missed Approach Segment	67
715.-799.	Reserved.....	68
CHAPTER 8	VHF/UHF DF PROCEDURES	
800.	General.....	71
801.-809.	Reserved.....	71
Section 1	VHF/UHF DF Criteria	71
810.	En Route Operations	71
811.	Initial Approach Segment	71
812.	Intermediate Approach Segment.....	72
813.	Final Approach Segment.....	72
814.	Missed Approach Segment	73
815.-819.	Reserved.....	73
Section 2	Communications	73
820.	Transmission Interval.....	73
821.-829.	Reserved.....	73
Section 3	Minimums	73
830.	Approach Minimums	73
831.-899.	Reserved.....	73

VOLUME 1. TABLE OF CONTENTS (Continued)

		Page
CHAPTER 9	LOCALIZER AND LOCALIZER TYPE DIRECTIONAL AIDS (LDA)	
900.	Feeder Routes, Initial Approach, and Intermediate Segments.....	9-1
901.	Use of Localizer Only	9-1
902.	Alignment	9-1
903.	Area.....	9-1
904.	Obstacle Clearance.....	9-1
905.	Descent Gradient.....	9-1
906.	MDA	9-1
907.	Missed Approach Segment	9-1
908.-999.	Reserved.....	9-1
CHAPTER 10	RADAR PROCEDURES	
1000.	General.....	87
1001.-1009.	Reserved.....	87
Section 1	Precision Approach Radar (PAR).....	87
1010.	System Components.....	87
1011.	Inoperative Components	87
1012.	Lost Communication Procedures.....	87
1013.	Feeder Routes and Initial Approach Segments.....	87
1014.	Intermediate Approach Segment.....	87
1015.	Descent Gradient.....	87
1016.	Altitude Selection.....	87
1017.-1019.	Reserved.....	88
Section 2	PAR Final Approach.....	88
1020.	Final Approach Segment.....	88
1021.	Final Approach OCS.....	88
1022.	Transitional Surface	88
1023.	Deleted	88
1024.	Obstacle Clearance.....	88
1025.	Effect of Obstacles Inside the DH	89
1026.	Glide Slope.....	89
1027.	Relocation of Glide Slope.....	89
1028.	Height Above Touchdown (HAT).....	89
1029.	Reserved.....	89

VOLUME 1. TABLE OF CONTENTS (Continued)

		Page
Section 3	PAR Missed Approach	89
1030.	Missed Approach Segment	89
1031.	Missed Approach Point (MAP)	89
1032.	Straight Missed Approach.....	89
1033.	Turning Missed Approach	92
1034.	Missed Approach Obstacle Clearance	92
1035.	Combination Straight and Turning Missed Approach Area	93
1036.-1039.	Reserved.....	93
Section 4	Airport Surveillance Radar (ASR).....	93
1040.	General.....	93
1041.	Initial Approach Segment	93
1042.	Intermediate Approach Segment.....	95
1043.	Altitude Selection.....	96
1044.	Final Approach Segment.....	96
1045.	Deviation from Established Radar Patterns	98
1046.	Radar Monitor	98
1047.	Lost Communication Procedures	98
1048.	Missed Approach Segment	98
1049.	Reserved.....	98
Section 5	Simultaneous PAR Procedures	98
1050.	General.....	98
1051.-1059.	Reserved.....	98
Section 6	Airborne Radar Procedures.....	98
1060.	General.....	98
1061.-1099.	Reserved.....	98

VOLUME 1. TABLE OF CONTENTS (Continued)

		Page
CHAPTER 11	HELICOPTER PROCEDURES	
Section 1	Administrative.....	99
1100.	General.....	99
1101.	Terminology.....	99
1102.	Deleted.....	99
1103.	Type of Procedure.....	99
1104.	Facilities for which Criteria are not Provided.....	99
1105.	Procedure Identification.....	99
Section 2	General Criteria.....	99
1106.	Application.....	99
1107.	Point in Space Approach.....	100
1108.	Approach Categories.....	100
1109.	Procedure Construction.....	100
1110.	Descent Gradient.....	100
1111.	Initial Approach Segments Based on Straight Courses and Arcs with Positive Course Guidance.....	100
1112.	Initial Approach Based on Procedure Turn.....	100
1113.	Intermediate Approach Segment Based on Straight Courses.....	101
1114.	Intermediate Approach Segment Based on an ARC.....	101
1115.	Intermediate Segment Within Procedure Turn Segment.....	101
1116.	Final Approach.....	101
1117.	Missed Approach Point.....	101
1118.	Straight Missed Approach Area.....	101
1119.	Straight Missed Approach Obstacle Clearance.....	102
1120.	Turning Missed Approach Area.....	102
1121.	Turning Missed Approach Obstacle Clearance.....	102
1122.	Combination Straight and Turning Missed Approach.....	102
1123.	Holding Alignment.....	102
1124.	Holding Area.....	102
Section 3	Takeoff and Landing Minimums.....	102
1125.	Application.....	102
1126.	Altitudes.....	102
1127.	Visibility.....	102
1128.	Visibility Credit.....	103
1129.	Takeoff Minimums.....	104

VOLUME 1. TABLE OF CONTENTS (Continued)

		Page
Section 4	On-Heliport VOR (No FAF)	
1130.	General.....	104
1131.	Initial and Intermediate Segments	104
1132.	Final Approach Segment.....	104
Section 5	TACAN, VOR/DME, and VOR with FAF.....	104
1133.	Final Approach Segment.....	104
1134.	Reserved.....	105
1135.	Missed Approach Point.....	105
1136.	ARC Final Approach Segment Radius	105
1137.	ARC Final Approach Segment Alignment	105
1138.	Reserved.....	105
Section 6	On-Heliport NDB, No FAF	105
1139.	General.....	105
1140.	Final Approach Segment.....	105
Section 7	NDB Procedures with FAF.....	106
1141.	General.....	106
1142.	Final Approach Segment.....	106
1143.	Missed Approach Point.....	106
Section 8	Reserved.....	106
1144.-1149.	Reserved.....	106
Section 9	ILS Procedures.....	106
1150.	General.....	106
1151.	Intermediate Approach Segment.....	106
1152.	Final Approach Segment.....	106
1153.	Missed Approach Area	106
1154.	Microwave ILS	106
1155.	Localizer and LDA	106

VOLUME 1. TABLE OF CONTENTS (Continued)

	Page
Section 10	Precision Approach Radar (PAR).....107
1156.	Intermediate Approach Segment.....107
1157.	Reserved.....107
1158.	Final Approach Segment.....107
1159.	Final Approach Alignment107
1160.	Final Approach Area.....107
1161.	Reserved.....107
1162.	Final Approach Obstacle Clearance Surface107
1163.	Transitional Surfaces108
1164.	Obstacle Clearance.....108
1165.	Glide Slope.....108
1166.	Relocation of the Glide Slope108
1167.	Adjustment of DH.....108
1168.	Missed Approach Obstacle Clearance108
1169.	Straight Missed Approach Area.....109
1170.	Turning Missed Approach Area.....110
1171.	Combination Straight and Turning Missed Approach Area110
Section 11	Airport Surveillance Radar (ASR).....111
1172.	Initial Approach Segment111
1173.	Intermediate Approach Segment.....112
1174.	Final Approach Segment.....112
1175.	Missed Approach Point.....112
1176.-1199.	Reserved.....112
CHAPTER 12	RESERVED
CHAPTER 13	RESERVED
CHAPTER 14	SIMPLIFIED DIRECTIONAL FACILITIES (SDF) PROCEDURES
1400.	General.....137
1401.-1409.	Reserved.....137
1410.	Feeder Routes.....137
1411.	Initial Approach Segment137
1412.	Intermediate Approach Segment.....137
1413.	Final Approach Segment.....137
1414.	Missed Approach Segment138
1415.	Back Course Procedures138
1416.-1499.	Reserved.....138

VOLUME 1. TABLE OF CONTENTS (Continued)

	Page
CHAPTER 15	AREA NAVIGATION (RNAV)
1500.	General..... 15-1
1501.	Terminology..... 15-1
1502.	Procedure Construction..... 15-2
1503.	Reserved..... 15-6
1504.	Reference Facilities..... 15-6
1505.	WP's..... 15-6
1506.	RWY WP and APT WP..... 15-7
1507.	Holding 15-7
1508.-1509.	Reserved..... 15-7
Section 1	En Route Criteria 15-7
1510.	En Route Obstacle Clearance Areas 15-7
1511.	Obstacle Clearance..... 15-10
1512.	Feeder Routes..... 15-10
1513.-1519.	Reserved..... 15-11
Section 2	Terminal Criteria..... 15-11
1520.	Terminal Turning Area Expansion 15-11
1521.	Initial Approach Segment 15-12
1522.	Intermediate Segment 15-14
1523.	Final Approach Segment..... 15-15
1524.-1529.	Reserved..... 15-15
Section 3	Missed Approach 15-15
1530.	General..... 15-15
1531.	Missed Approach Segment 15-15
1532.	MAP 15-16
1533.	Straight Missed Approach..... 15-16
1534.	Turning Missed Approach 15-18
1535.	Combination Straight and Turning Missed Approach..... 15-18
1536.	Clearance Limit..... 15-20
1537.-1539.	Reserved..... 15-20
Section 4	Approach Minimums 15-20
1540.	Approach Minimums 15-20
1541.-1599.	Reserved..... 15-20

VOLUME 1. TABLE OF CONTENTS (Continued)

	Page
CHAPTER 16	RESERVED
CHAPTER 17	EN ROUTE CRITERIA
1700.-1709.	Reserved..... 173
Section 1	VHF Obstacle Clearance Area..... 173
1710.	En Route Obstacle Clearance Areas 173
1711.	Primary Area..... 173
1712.	Secondary Areas 173
1713.	Turning Area..... 174
1714.	Application of Turning Area Criteria 175
1715.	Turn Area Template..... 175
1716.	Changeover Points (COP)..... 178
1717.	Course Change Effect 179
1718.	Minimum En Route Instrument Altitudes (MEA)..... 179
1719.	Protected En Route Areas 180
Section 2	VHF Obstacle Clearance..... 180
1720.	Obstacle Clearance, Primary Area..... 180
1721.	Obstacle Clearance, Secondary Areas 180
1722.	Obstacle Clearance Graph..... 181
1723.-1729.	Reserved..... 182
Section 3	Altitudes 182
1730.	Minimum Crossing Altitudes (MCA)..... 182
1731.	En Route Minimum Holding Altitudes..... 183
1732.-1739.	Reserved..... 183
Section 4	Navigational Gaps..... 183
1740.	Navigational Gap Criteria 183
1741.-1749.	Reserved..... 185
Section 5	Low Frequency Airways or Routes 185
1750.	LF Airways or Routes..... 185
1751.-1759.	Reserved..... 186

VOLUME 1. TABLE OF CONTENTS (Continued)

		Page
Section 6	Minimum Divergence Angles.....	186
1760.	General.....	186
1761.	VHF Fixes.....	186
1762.	LF or VHF/LF Fixes	187
1763.-1799.	Reserved.....	187
APPENDIX 1	APPENDIX APPLICATION, GLOSSARY, ACRONYMS, AND ABBREVIATIONS (6 Pages)	
1.	Appendix Application.....	1
2.	Glossary	1
3.	Acronyms and Abbreviations	3
APPENDIX 2	RESERVED	
APPENDIX 3	REFERENCES (2 Pages)	
1.	References.....	1
APPENDIX 4	TABLE OF TANGENTS (5 Pages)	
1.	Table of Tangents	1
APPENDIX 5	APPROACH LIGHTING SYSTEMS (7 Pages)	
1.	Approach Lighting Systems.....	1
2.	Nonstandard Systems.....	1
3.	ALSF-1 (Type A ₁)	1
4.	ALSF-2 (Type A).....	2
5.	SALS.....	3
6.	SSALS, SSALF, and SSALR (Type A ₃)	3
7.	MALS, MALSF (Type 4 ₄), and MALSR (Type A ₅)	4
8.	ODALS	5
9.	LDIN, Lead-In Lighting System.....	6
10.	REIL.....	7
11.	HIRL	7
12.	MIRL.....	7
13.	TDZ/CL.....	7

THIS PAGE INTENTIONALLY LEFT BLANK

TIL03-048

CHAPTER 1. ADMINISTRATIVE**SECTION 1. SCOPE**

1. PURPOSE. This order contains criteria that shall be used to formulate, review, approve, and publish procedures for instrument approach and departure of aircraft to and from civil and military airports. These criteria are for application at any location over which an appropriate United States agency exercises jurisdiction.

2. DISTRIBUTION. This order is distributed to selected Federal Aviation Administration (FAA) addressees. For distribution within the Department of Defense, see pages v and vi.

3. CANCELLATION. Order 8260.34, Glide Slope Threshold Crossing Height Requirements, dated 10/26/83, is canceled. This change also incorporates criteria contained in VN Supplements 2 and 3 to Order 8260.3B; therefore, VN SUP 2, dated 10/8/92, and VN SUP 3, dated 1/11/93, are canceled.

4. EXISTING PROCEDURES. Existing procedures shall comply with these standards. Approval of nonstandard procedures as required is specified in paragraph 141.

5. TYPES OF PROCEDURES. Criteria are provided for the following types of authorized instrument procedures:

a. Precision Approach (PA).

(1) Straight-In. A descent in an approved procedure where the navigation facility alignment is normally on the runway centerline, and glide slope (GS) information is provided. For example, Precision Approach Radar (PAR), Instrument Landing System (ILS), and Microwave Landing System (MLS) procedures are precision approaches.

(2) Simultaneous. A procedure that provides for approaches to parallel runways. This procedure uses two or more ILS-equipped parallel runways. Simultaneous approaches, when authorized, shall be radar monitored. Military commanders may approve simultaneous approaches based upon dual precision radar.

b. Nonprecision Approach (NPA).

(1) Straight-In. A descent in an approved procedure in which the final approach course (FAC) alignment and descent gradient permit its authorization of straight-in landing minimums.

c. Departure Procedures. Procedures designed to provide obstacle clearance during instrument departures.

6. WORD MEANINGS. Word meanings as used in this manual:

a. Shall or Must means that application of the criteria is mandatory.

b. Should means that application of the criteria is recommended.

c. May means that application of the criteria is optional.

7.-119. RESERVED.

SECTION 2. ELIGIBILITY, APPROVAL, AND RETENTION**120. ELIGIBILITY.**

a. Military Airports. Procedures at military airports shall be established as required by the directives of the appropriate military service.

b. Civil Airports. Instrument procedures shall be provided at civil airports open to the aviation public whenever a reasonable need is shown. No minimum number of potential instrument approaches is specified; however, the responsible FAA office must determine that a public procedure will be beneficial to more than a single user or interest. Private procedures, for the exclusive use of a single interest, may be provided on a reimbursable basis under Title 14 of the Code of Federal Regulations (14 CFR) Part 171, where applicable, if they do not unduly conflict with the public use of airspace. Reasonable need is deemed to exist when the instrument flight procedure will be used by:

(1) A certificated air carrier, air taxi, or commercial operator; or

(2) Two or more aircraft operators whose activities are directly related to the commerce of the community.

(3) Military aircraft.

121. REQUESTS FOR PROCEDURES. Requests for military procedures are processed as described by the appropriate military service. No special form is required for requesting civil procedures. Civil requests may be made by letter to the appropriate Regional Office. Requests for civil procedures shall be accepted from any aviation source, provided the request shows that the airport owner/operator has been advised of this request. (This advice is necessary only when the request is for an original procedure to an airport not already served by an approach procedure.) The FAA will advise airport owners/operators of additional requests for procedures as soon as possible after receipt thereof.

122. APPROVAL. Where a military requirement or reasonable civil need has been established, a request for an instrument approach procedure (IAP) and/or instrument departure procedure for an airport shall be approved if the following minimum standards are met:

a. Airport. The airport landing surfaces must be adequate to accommodate the aircraft that can be reasonably expected to use the procedure. Appropriate runway markings, hold position markings, and signs, required by AC 150/5340-1, Marking of Paved Areas on Airports, shall be established and in place; and all runway design standards in appendix 16 of AC 150/5300-13, Airport Design, must be met. Runway lighting is required for approval of night instrument operations. **EXCEPTION:** Do NOT deny takeoff and departure procedures at night due solely to the absence of runway edge lights. The airport must have been found acceptable for instrument flight rules (IFR) operations as a result of an airport airspace analysis conducted pursuant to Order 7400.2, Procedures for Handling Airspace Matters, and/or appropriate military directives, as applicable. Only circling minimums shall be approved to airports where the runways are not clearly defined.

b. Navigation Facility. All instrument and visual navigation facilities used must successfully pass flight inspection.

c. Obstacle Marking and Lighting. Obstacles which penetrate 14 CFR Part 77 imaginary surfaces are obstructions and, therefore, should be marked and lighted, insofar as is reasonably possible under FAA Advisory Circular AC 70/7460.1, Obstruction Marking and Lighting. Those penetrating the 14 CFR Part 77 approach and transitional surfaces should be removed

or made conspicuous under that AC. Normally, objects which are shielded need not be removed or made conspicuous.

NOTE: In military procedures, the appropriate military directives apply.

d. Weather Information. Terminal weather observation and reporting facilities must be available for the airport to serve as an alternate airport. Destination minimums may be approved when a general area weather report is available prior to commencing the approach and approved altimeter settings are available to the pilot prior to and during the approach consistent with communications capability.

e. Communications. Air-to-ground communications must be available at the initial approach fix (IAF) minimum altitude and when the aircraft executing the missed approach reaches the missed approach altitude. At lower altitudes, communications shall be required where essential for the safe and efficient use of airspace. Air-to-ground communication normally consists of ultra high frequency (UHF) or very high frequency (VHF) radio, but high frequency (HF) communication may be approved at locations which have a special need and capability. Other suitable means of point-to-point communication, such as commercial telephone, are also required to file and close flight plans.

123. RETENTION AND CANCELLATION. Civil instrument procedures shall be canceled when a re-evaluation of the usefulness of an IAP indicates that the benefits derived are not commensurate with the costs of retaining the procedure. This determination will be based upon an individual evaluation of requirements peculiar to each specific location, and will consider airport complexity, military requirements, planned airport expansion, and the need for a backup or supplement to the primary instrument approach system. Certain special procedures exist, generally based on privately operated navigation facilities. When a procedure based on a public facility is published, special procedures for that airport shall be canceled unless retention provides an operational advantage to the user. Before an instrument procedure is canceled, coordination with civil and military users shall be effected. Care shall be taken not to cancel procedures required by the military or required by air carrier operators at provisional or alternate airports. Military procedures shall be retained or canceled as required by the appropriate military authority.

124.-129. RESERVED

SECTION 3. RESPONSIBILITY AND JURISDICTION

130. RESPONSIBILITY.

a. Military Airports. The United States Army, Navy, Air Force, and Coast Guard, shall establish and approve instrument procedures for airports under their respective jurisdictions. The FAA will accept responsibility for the development and/or publication of military procedures when requested to do so by the appropriate military service through an interagency agreement. Military instrument procedures are official procedures. The FAA (AVN-100 Regional FPO) shall be informed when military procedures are canceled.

b. Civil Airports. The FAA shall establish and approve instrument procedures for civil airports.

c. Military Procedures at Civil Airports. Where existing FAA approach or departure procedures at civil airports do not suffice, the military shall request the FAA to develop procedures to meet military requirements. Modification of an existing FAA procedure or development of a new procedure may meet these requirements. The FAA shall formulate, coordinate with the military and industry, and publish and maintain such procedures. The military shall inform the FAA when such procedures are no longer required.

131. JURISDICTION. The United States Army, Navy, Air Force, Coast Guard, and Marine Corps Commanding Officers, or FAA Regional Directors having jurisdiction over airports are responsible for initiating action under these criteria to establish or revise TERPS when a reasonable need is identified, or where:

a. New facilities are installed.

b. Changes to existing facilities necessitate a change to an approved procedure.

c. Additional procedures are necessary.

d. New obstacles or operational uses require a revision to the existing procedure.

132.-139. RESERVED.

SECTION 4. ESTABLISHMENT

140. FORMULATION. Proposed procedures shall be prepared under the applicable portion of this publication as determined by the type and location of navigation facility and procedure to be used. To permit use by aircraft with limited navigational equipment, the complete procedure should be formulated on the basis of a single navigation facility whenever possible. However, the use of an additional facility of the same

or different type in the procedure to gain an operational advantage is permitted.

141. NONSTANDARD PROCEDURES. The standards contained in this manual are based on reasonable assessment of the factors which contribute to errors in aircraft navigation and maneuvering. They are designed primarily to assure that safe flight operations for all users result from their application. The dimensions of the obstacle clearance areas are influenced by the need to provide for a smooth, simply computed progression to and from the en route system. Every effort shall be made to formulate procedures in accordance with these standards; however, peculiarities of terrain, navigation information, obstacles, or traffic congestion may require special consideration where justified by operational requirements. In such cases, nonstandard procedures that deviate from these criteria may be approved, provided they are fully documented and an equivalent level of safety exists. A nonstandard procedure is not a substandard procedure, but is one that has been approved after special study of the local problems has demonstrated that no derogation of safety is involved. The FAA, Flight Technologies and Procedures Division, AFS-400, is the approving authority for nonstandard civil procedures. Military procedures which deviate from standards because of operational necessity, and in which an equivalent level of safety is not achieved, shall include a cautionary note to identify the hazard and shall be marked "not for civil use."

142. CHANGES. Changes in instrument procedures shall be prepared and forwarded for approval in the same manner as in the case of new procedures. Changes so processed will not be made solely to include minor corrections necessitated by changes in facility frequencies, variation changes, etc., or by other minor changes not affecting the actual instrument procedure. Changes that require reprocessing are those that affect fix, course, altitude, or published minimums.

143.-149. RESERVED.

SECTION 5. COORDINATION

150. COORDINATION. It is necessary to coordinate instrument procedures to protect the rights of all users of airspace.

a. Military Airports. All instrument procedures established or revised by military activities for military airports shall be coordinated with the FAA or appropriate agency or an overseas host nation. When a procedure may conflict with other military or civil activities, the procedure shall also be coordinated with those activities.

b. Civil Airports. Prior to establishing or revising instrument procedures for civil airports, the FAA shall, as required, coordinate such procedures with the appropriate civil aviation organizations. Coordination with military activities is required when a military operating unit is based at the airport or when the proximity of a military airport may cause procedure conflicts.

c. Air Traffic Control (ATC). Prior to establishing or revising instrument procedures for a military or civil airport, the initiating office shall coordinate with the appropriate FAA Air Traffic office to ensure compatibility with air traffic flow and to assess the impact of the proposed procedure on current or future air traffic programs.

d. Airspace Actions. Where action to designate controlled airspace for a procedure is planned, the airspace action should be initiated sufficiently in advance so that effective dates of the procedure and the airspace action will coincide.

e. Notice to Airmen (NOTAM). A NOTAM to RAISE minimums may be issued in case of emergencies; i.e., facility outages, facility out-of-tolerance conditions, new construction that penetrates critical surfaces, etc. NOTAM's may also be issued to LOWER minimums when a supporting facility is added and a significant change in minimums (60 feet in MDA/DH or a reduction in visibility) will result. A NOTAM may be issued to RAISE OR LOWER minimums as appropriate on a no-FAF procedure when a procedure turn (PT) altitude is modified as the result of construction or terrain, or when a facility restriction is removed. However, a complete new procedure may not be issued by NOTAM, except where military requirements dictate. ATC shall be advised of the required NOTAM action prior to issuance and normal coordination shall be effected as soon as practical.

151. COORDINATION CONFLICTS. In areas under the FAA jurisdiction, coordination conflicts that cannot be resolved at the field level shall be submitted to the appropriate FAA region for additional coordination and resolution. Problems that are unresolved at the regional level shall be forwarded to the FAA, AFS-400, for action. If the problem involves a military procedure, parallel action through military channels shall be taken to expedite coordination at the appropriate level.

152.-159. RESERVED.

SECTION 6. IDENTIFICATION OF PROCEDURES

160. IDENTIFICATION OF PROCEDURES.

Instrument procedures shall be identified to be meaningful to the pilot, and to permit ready identification in ATC phraseology.

161. STRAIGHT-IN PROCEDURE IDENTIFICATION. Instrument procedures that meet criteria for authorization of straight-in landing minima shall be identified by a prefix describing the navigational system providing the final approach guidance and the runway to which the final approach course is aligned:

a. Non-RNAV. ILS runway (RWY) 18R, localizer (LOC) back course (BC) RWY 7, tactical air navigational aid (TACAN) RWY 36, localizer type directional aid (LDA) RWY 4, nondirectional radio beacon (NDB) RWY 21, VHF omnidirectional radio range (VOR) RWY 15, VOR/distance measuring equipment (DME) RWY 6, ILS or TACAN RWY 9, etc. A slash (/) indicates more than one type of equipment is required to execute the final approach; e.g., VOR/DME, etc. ILS procedures do not require DME to fly the final approach, even if a DME fix has been substituted for one of the marker beacons, therefore, ILS procedures shall not be named ILS/DME. If a procedure requires DME to fly the final approach, the suffix "DME" shall be added; e.g., LOC/DME RWY (number). A chart shall be noted to indicate RADAR is required for approach minima. When a LOC procedure is published on an ILS chart, it is a combined procedure. When procedures are combined, the word "or" shall indicate either type of equipment may be used to execute the final approach; e.g., ILS or LOC/DME, ILS or TACAN, VOR/DME or TACAN, etc. Where more than one approach using the same final approach guidance is developed to the same runway, identify each for the runway/navigational aid combination with alphabetical suffix beginning at the end of the alphabet; e.g., ILS Z RWY 28L (first procedure), ILS Y RWY 28L (second procedure), ILS X RWY 28L (third procedure), etc.

b. RNAV. Identify WAAS, Baro VNAV, and GPS approach procedures as RNAV (sensor) RWY (Number); e.g., RNAV (GPS) RWY 21, RNAV (GPS, DME/DME) RWY 15.

NOTE: The published minima lines will identify required RNAV sensors; e.g., LPV, LNAV/VNAV (includes degraded WAAS and Baro VNAV), or LNAV (includes GPS and WAAS without glidepath). A single RNAV approach will be

published depicting LPV and/or LNAV/VNAV, and/or LNAV minimums where they share the same courses and altitudes.

c. OTHER RNAV. Identify VOR/DME E and LORAN based RNAV procedures as (system) RNAV RWY (number); e.g., VOR/DME RNAV RWY 13, LORAN RNAV RWY 31.

162. CIRCLING PROCEDURE IDENTIFICATION. When an **approach** procedure does not meet criteria for straight-in landing minimums authorization, it shall be identified by the type of navigational aid (NAVAID) which provides final approach guidance, and an alphabetical **suffix starting with the beginning of the alphabet**. The first procedure formulated shall bear the suffix "A" even though there may be no intention to formulate additional procedures. If additional procedures are formulated, **they shall be identified alphabetically in sequence, e.g., VOR-A, VOR/DME-B, NDB-C, NDB-D, LDA-E, RNAV-A, etc.** A revised procedure will bear its original identification.

163. DIFFERENTIATION. Where high altitude procedures are required, the procedure identification shall be prefixed with the letters "HI" e.g., HI-VOR RWY 5.

164.-169. RESERVED.

SECTION 7. PUBLICATION

170. SUBMISSION. Instrument procedures shall be submitted by the approving authority on forms provided

by the originating agency. A record of coordination shall be maintained by the originating agency. Procedures shall be routed under current orders or directives of the originating agency.

171. ISSUANCE. The following are designated as responsible offices for the release of approved instrument procedures for each agency.

a. Army. Director, U.S. Army Aeronautical Services Agency.

b. Navy and Marine Corps. Chief of Naval Operations (CNO), Naval Flight Information Group.

c. Air Force. Headquarters, Air Force Flight Standards Agency, Instrument Standards Division.

d. Coast Guard. Commandant, U.S. Coast Guard.

e. Civil. Administrator, FAA.

172. EFFECTIVE DATE. TERPS and revisions thereto shall be processed in sufficient time to permit publication and distribution in advance of the effective date. Effective dates should normally coincide with scheduled airspace changes except when safety or operational effectiveness is jeopardized. In case of emergency, or when operational effectiveness dictates, approved procedures may be disseminated by NOTAM (see paragraph 150e). Procedures disseminated by NOTAM must also be processed promptly in the normal fashion and published in appropriate instrument procedures charts and in the Federal Register when required.

173. MATHEMATICS CONVENTION.**a. Definition of Mathematical Functions.**

$a + b$ indicates addition

$a - b$ indicates subtraction

$a \times b$ indicates multiplication

$\frac{a}{b}$ indicates division

$(a \times b)$ indicates the result of the process within the parenthesis

$|a - b|$ indicates absolute value {the result of the process between the vertical lines is assigned a positive sign}

\approx indicates approximate equality

\sqrt{a} indicates the square root of quantity "a"

a^2 indicates $a \times a$

$\tan(a)$ indicates the tangent of "a" degrees

$\tan^{-1}(a)$ indicates the arc tangent of "a"

$\sin(a)$ indicates the sine of "a" degrees

$\sin^{-1}(a)$ indicates the arc sine of "a"

$\cos(a)$ indicates the cosine of "a" degrees

$\cos^{-1}(a)$ indicates the arc cosine of "a"

b. Operational Precedence (Order of Operations).

First: Grouping Symbols: parentheses, brackets, braces, fraction bars, etc.

Second: Functions: tangent, sine, cosine, arcsine and other defined functions

Third: Exponentiation: powers and roots

Fourth: Multiplication and Division: products and quotients

Fifth: Addition and Subtraction: sums and differences

e.g.,

$5 - 3 \times 2 = -1$ because multiplication takes precedence over subtraction

$(5 - 3) \times 2 = 4$ because parentheses take precedence over multiplication

$\frac{6^2}{3} = 12$ because exponentiation takes precedence over division

$\sqrt{9 + 16} = 5$ because the square root sign is a grouping symbol

$\sqrt{9} + \sqrt{16} = 7$ because roots take precedence over addition

$\frac{\sin(30^\circ)}{0.5} = 1$ because functions take precedence over division

$\sin\left(\frac{30^\circ}{0.5}\right) = 0.8660254$ because parentheses take precedence over functions

NOTES ON CALCULATOR USAGE:

1. Most calculators are programmed with these rules of precedence.
2. When possible, let the calculator maintain all of the available digits of a number in memory rather than re-entering a rounded number. For highest accuracy from a calculator, any rounding that is necessary should be done at the latest opportunity.

174. INFORMATION UPDATE. For your convenience, FAA Form 1320-19, Directive Feedback Information, is included at the end of this order to provide any comments on deficiencies found, clarifications needed, or suggested improvements regarding the contents to this order. When forwarding comments

to the originating office for consideration, please provide a complete explanation of why the suggested change is necessary.

175.-199. RESERVED

THIS PAGE INTENTIONALLY LEFT BLANK

CHAPTER 2. GENERAL CRITERIA

200. SCOPE. This chapter contains only that information common to all types of TERPS. Criteria, which do not have general application, are located in the individual chapters concerned with the specific types of facilities.

SECTION 1. COMMON INFORMATION

201. TERPS. Concept of Primary Required Obstacle Clearance (ROC). The title of this order, United States Standard for Terminal Instrument Procedures (TERPS), contains a key word in defining the order's content. The word is "STANDARD;" something set up and established by authority as a rule for the measure of quantity, weight, extent, value, or quality.

a. The TERPS document specifies the minimum measure of obstacle clearance that is considered by the FAA (the Federal authority) to supply a satisfactory level of vertical protection. The validity of the protection is dependent, in part, on assumed aircraft performance. In the case of TERPS, it is assumed that aircraft will perform within certification requirements.

b. The following is an excerpt from the foreword of this order: "These criteria are predicated on normal aircraft operations for considering obstacle clearance requirements." Normal aircraft operation means all aircraft systems are functioning normally, all required navigational aids (NAVAID's) are performing within flight inspection parameters, and the pilot is conducting instrument operations utilizing instrument procedures based on the

TERPS standard to provide ROC. While the application of TERPS criteria indirectly addresses issues of flyability and efficient use of NAVAID's, the major safety contribution is the provision of obstacle clearance standards. This facet of TERPS allows aeronautical navigation in instrument meteorological conditions (IMC) without fear of collision with unseen obstacles. ROC is provided through application of level and sloping OCS.

202. Level OCS. The level OCS concept is applicable to "level flight" segments. These segments are level flight operations intended for en route, initial, intermediate segments, and nonprecision final approaches. A single ROC value is applied over the length of the segment. These values were determined through testing and observation of aircraft and pilot performance in various flight conditions. Typical ROC values are: for en route procedure segments, 1,000 feet (2,000 over designated mountainous terrain); and for initial segments, 1,000 feet, 500 feet in intermediate segments, and 350/300/250 feet in final segments.

a. This method of applying ROC results in a horizontal band of airspace that cannot be penetrated by obstacles. Since obstacles always extend upward from the ground, the bottom surface of the ROC band is mathematically placed on top of the highest obstacle within the segment. The depth (ROC value) of the band is added to the obstacle height to determine the minimum altitude authorized for the segment. The bottom surface of the ROC band is referred to as the level OCS. Therefore, level flight segments are evaluated by the level OCS application standard (see figure 1-1).

Policy
Memo
Aug 17
2009

Figure 1-1. Minimum Segment Altitude. Par 202a

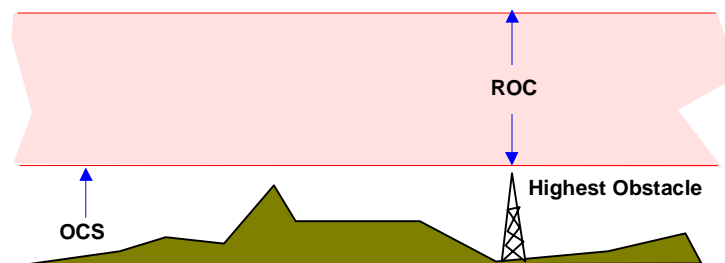

203. Sloping Obstacle Clearance Surfaces (OCS). The method of applying ROC, in segments dedicated to descending on a glidepath or climbing in a departure or missed approach segment, requires a different obstacle clearance concept than the level OCS because the ROC value must

vary throughout the segment. The value of ROC near the runway is relatively small, and the value at the opposite end of the segment is sufficient to satisfy one of the level surface standards above. It follows then, that a sloping OCS is a more appropriate method of ROC application.

NOTE: Slope ratios are normally expressed in terms of rise over run in engineering and professional technical jargon. However, TERPS has traditionally expressed slope ratios in terms of run over rise; e.g., 34:1, 40:1.

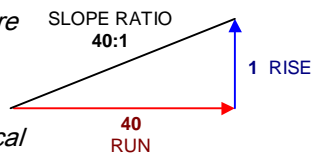

a. Descending on a Precision Glidepath. The obstacle evaluation method for descent on a glidepath is the application of a descending OCS below

the glidepath. The vertical distance between the glidepath and the OCS is ROC; i.e., $ROC = (\text{glidepath height}) - (\text{OCS height})$. The ROC decreases with distance from the final approach fix as the OCS and glidepath converge on the approach surface baseline (ASBL) height (see figure 1-2). The OCS slope and glidepath angle values are interdependent: $OCS \text{ Slope} = 102 \div \text{glidepath angle}$; or $\text{glidepath angle} = 102 \div OCS \text{ slope}$. This relationship is the standard that determines the ROC value since $ROC = (\text{glidepath height}) - (\text{OCS height})$.

Figure 1-2. Precision Glidepath Descent. Par 203a.

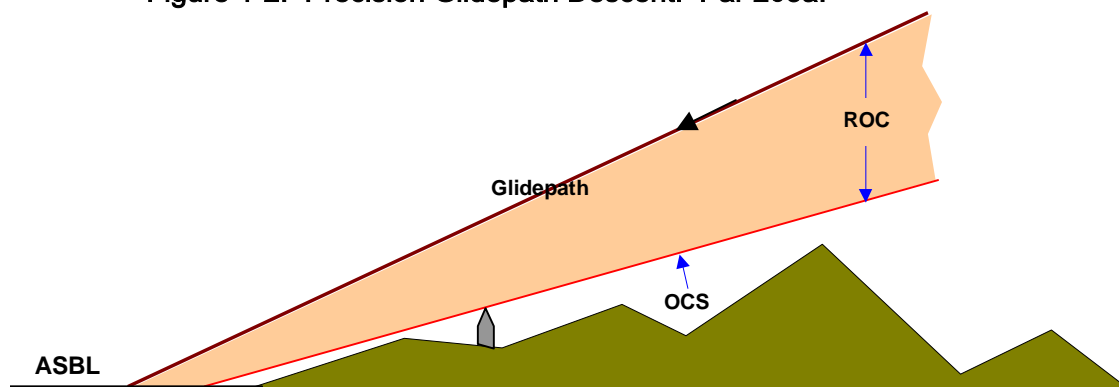

(1) If the OCS is penetrated, the OCS slope may be adjusted upward, thereby increasing the glidepath angle. The glidepath angle would increase because it is dependent on the required slope.

(2) Descent on a glidepath generated by systems that do not meet the system precision requirements of ICAO PANS-OPs, Annex 10, such as barometric vertical navigation (Baro-VNAV), provide ROC through application of a descending sloping surface based on standards using differing formulas, but the concept is the same.

b. Climbing on departure or missed approach. The concept of providing obstacle clearance in the climb segment, in instrument procedures, is based on the aircraft maintaining a minimum climb gradient. The climb gradient must be sufficient to increase obstacle clearance along the flightpath so that the minimum ROC for the subsequent segment is achieved prior to leaving the climb

segment (see figure 1-3). For TERPS purposes, the MINIMUM climb gradient that will provide adequate ROC in the climb segment is 200 ft/NM.

(1) The obstacle evaluation method for a climb segment is the application of a rising OCS below the minimum climbing flightpath. Whether the climb is for departure or missed approach is immaterial. The vertical distance between the climbing flightpath and the OCS is ROC. ROC for a climbing segment is defined as $ROC = 0.24 \text{ CG}$. This concept is often called the 24% rule. Altitude gained is dependent on climb gradient (CG) expressed in feet per NM. The minimum ROC supplied by the 200 ft/NM CG is 48 ft/NM ($0.24 \times 200 = 48$). Since 48 of the 200 feet gained in 1 NM is ROC, the OCS height at that point must be 152 feet ($200 - 48 = 152$), or 76% of the CG ($152 \div 200 = 0.76$). The slope of a surface that rises 152 over 1 NM is 40 ($6076.11548 \div 152 = 39.97 = 40$).

Figure 1-3. Climb Segment. Par 202b.

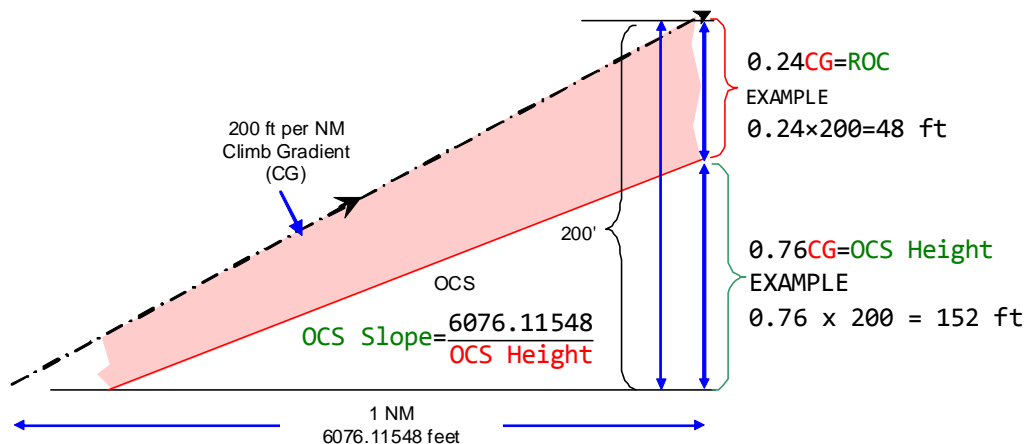

(2) Where an obstruction penetrates the OCS, a nonstandard climb gradient (greater than 200 ft/NM) is required to provide adequate ROC. Since the climb gradient will be greater than 200 ft/NM, ROC will be greater than 48 ft/NM ($0.24 \times CG > 200 = ROC > 48$). The nonstandard ROC expressed in ft/NM can be calculated using the formula: $(0.24 h) \div (0.76 d)$ where "h" is the height of the obstruction above the altitude from which the climb is initiated, and "d" is the distance in NM from the initiation of climb to the obstruction. Normally, instead of calculating the nonstandard ROC value, the required climb gradient is calculated directly using the formula: $h \div (0.76d)$.

c. In the case of an instrument departure, the OCS is applied during the climb until at least the minimum en route value of ROC is attained. The OCS begins at the departure end of runway, at the elevation of the runway end. It is assumed aircraft will cross the departure end-of-runway at a height of at least 35 ft. However, for TERPS purposes, aircraft are assumed to lift off at the runway end (unless the procedures state otherwise). The ROC value is zero at the runway end, and increases along the departure route until the appropriate ROC value is attained to allow en route flight to commence.

d. In the case of a missed approach procedure, the climbing flight path starts at the height of MDA or DA minus height loss. The OCS starts approximately at the MAP/DA point at an altitude of MDA/DA minus the final segment ROC and adjustments. Therefore, the final segment ROC is assured at the beginning of the OCS, and increases as the missed approach route

progresses. The OCS is applied until at least the minimum initial or en route value of ROC is attained, as appropriate.

e. Extraordinary circumstances, such as a mechanical or electrical malfunction, may prevent an aircraft from achieving the 200 ft/NM minimum climb gradient assumed by TERPS. In these cases, adequate obstacle clearance may not be provided by published instrument procedures. Operational procedures contained outside TERPS guidelines are required to cope with these abnormal scenarios.

204.-209. RESERVED.

210. UNITS OF MEASUREMENT. Units of measurement shall be expressed as set forth below:

a. Bearings, Courses, and Radials. Bearings and courses shall be expressed in degrees magnetic. Radials shall also be expressed in degrees magnetic, and shall further be identified as radials by prefixing the letter "R" to the magnetic bearing FROM the facility. For example, R-027 or R-010.

b. Altitudes. The unit of measure for altitude in this publication is feet. Published heights below the transition level (18,000 ft) shall be expressed in feet above mean sea level (MSL); e.g. 17,900 ft. Published heights at and above the transition level (18,000 ft) shall be expressed as flight levels (FL); e.g., FL 180, FL 190, etc. See Title 14 of the Code of Federal Regulations (14 CFR) Part 91.121.

c. Distances. Develop all distances in nautical miles (NM) (6076.11548 ft or 1852 m per NM) and hundredths thereof, except where feet are required. Use the following formulas for feet and meter conversions:

$$\text{feet} = \frac{\text{meters}}{0.3048} \quad \text{meters} = \text{feet} \times 0.3048$$

When applied to visibilities, distances shall be expressed in statute miles (SM) (5280 ft per SM) and the appropriate fractions thereof. (1/8 SM = 660 ft; 1/4 SM = 1320 ft; 3/8 SM = 1980 ft; 1/2 SM = 2640 ft; 5/8 SM = 3300 ft; 3/4 SM = 3960; 7/8 SM = 4620 ft). Runway visual range (RVR) must be expressed in feet.

d. Speeds. Aircraft speeds must be expressed in knots indicated airspeed (KIAS).

e. Determination of Correctness of Distance and Bearing Information. The approving agency is the authority for correctness of distance and bearing information, except that within the United States, its territories, and possessions, the National Oceanic and Atmospheric Administration is the authority for measurements between all civil navigation aids and between those facilities incorporated as part of the National Airspace System (NAS).

211. POSITIVE COURSE GUIDANCE (PCG). PCG must be provided for feeder routes, initial (except as provided for in paragraph 233b), intermediate, and final approach segments. The segments of a procedure wherein PCG is provided must be within the service volume of the facility(ies) used, except where Expanded Service Volume (ESV) has been authorized. PCG may be provided by one or more of the navigation systems for which criteria has been published.

212. APPROACH CATEGORIES (CAT). Aircraft performance differences have an effect on

the airspace and visibility needed to perform certain maneuvers. Because of these differences, aircraft manufacturer/operational directives assign an alphabetical category to each aircraft so that the appropriate obstacle clearance areas and landing and departure minimums can be established in accordance with the criteria in this order. The categories used and referenced throughout this order are Category A; B; C; D, and/or E. Aircraft categories are defined in Part 97.

213. APPROACH CATEGORY APPLICATION.

The approach category operating characteristics must be used to determine turning radii minimums and obstacle clearance areas for circling and missed approaches.

214. PROCEDURE CONSTRUCTION. An IAP may have four separate segments. They are the initial, intermediate, final, and missed approach segments. In addition, an area for circling the airport under visual conditions shall be considered. An approach segment begins and ends at the plotted position of the fix; however, under some circumstances certain segments may begin at specified points where no fixes are available. The fixes are named to coincide with the associated segment. For example, the intermediate segment begins at the intermediate fix (IF) and ends at the precise final approach fix (PFAF). The order in which this chapter discusses the segments is the same order in which the pilot would fly them in a completed procedure; that is from an initial, through an intermediate, to a final approach. In constructing the procedure, the FAC should be identified first because it is the least flexible and most critical of all the segments. Then establish the other segments to produce an orderly maneuvering pattern responsive to the local traffic flow and to conserve controlled airspace to the extent possible (see figure 1-4).

THIS PAGE INTENTIONALLY LEFT BLANK

Figure 1-4. SEGMENTS OF AN APPROACH PROCEDURE. Par 214.

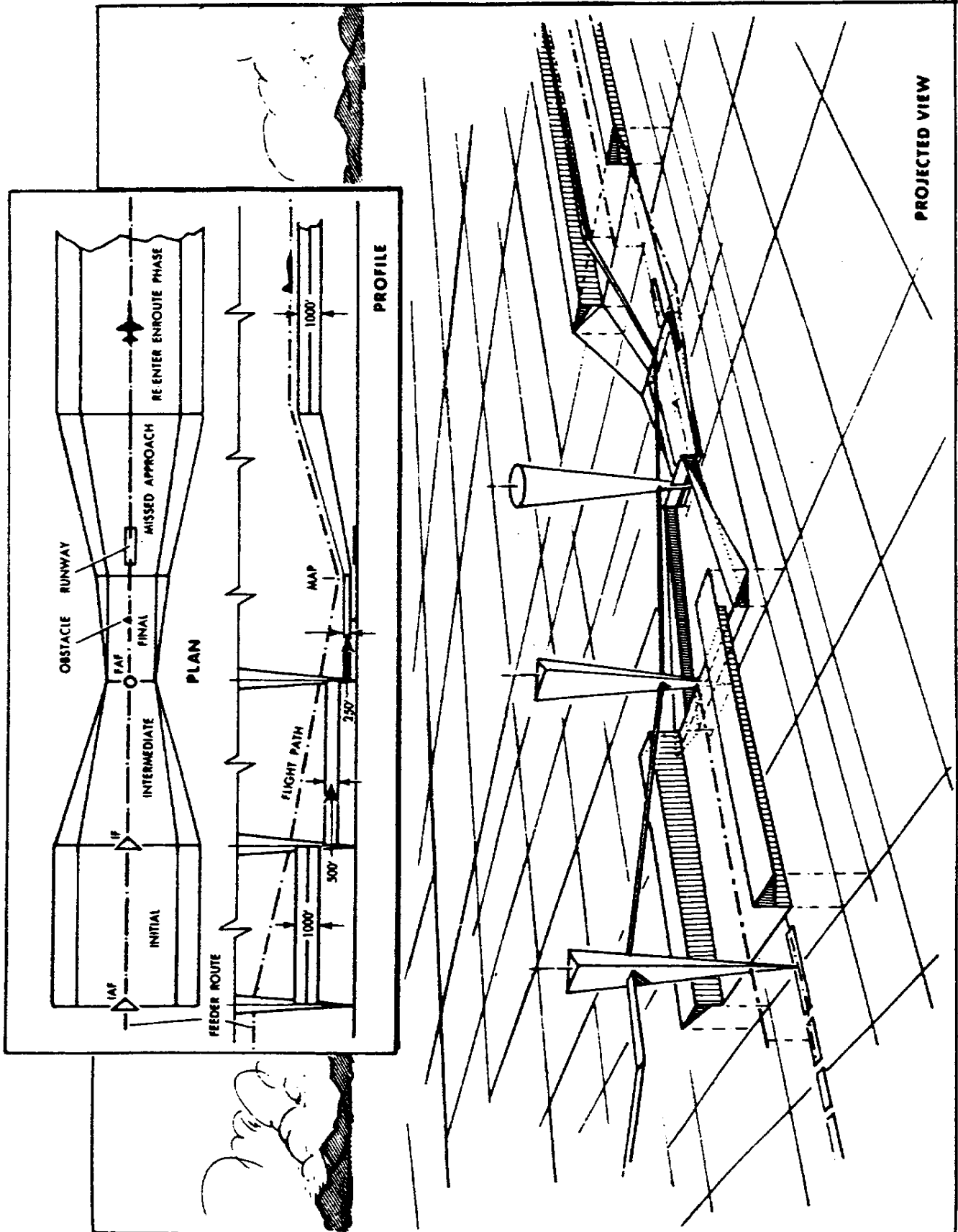

215. CONTROLLING OBSTACLE(S). The controlling obstacle in the final approach segment shall be identified in procedures submitted for publication.

216.-219. RESERVED.

SECTION 2. EN ROUTE OPERATIONS

220. FEEDER ROUTES. When the IAF is part of the en route structure, there may be no need to designate additional routes for aircraft to proceed to the IAF. In some cases, however, it is necessary to designate feeder routes from the en route structure to the IAF. Only those feeder routes which provide an operational advantage shall be established and published. These should coincide with the local air traffic flow. The length of the feeder route shall not exceed the operational service volume of the facilities which provide navigational guidance, unless additional frequency protection is provided. En route airway obstacle clearance criteria shall apply to feeder routes. The minimum altitude established on feeder routes shall not be less than the altitude established at the IAF.

a. **Construction of a feeder route connecting to a course reversal segment.** The area considered for obstacle evaluation is oriented along the feeder route at a width appropriate to the type of route (VOR or NDB). The area terminates at the course reversal fix, and is defined by a line perpendicular to the feeder course through the course reversal fix.

b. **The angle of intersection between the feeder route course and the next straight segment (feeder/initial) course shall not exceed 120°.**

c. **Descent Gradient.** The **OPTIMUM** descent gradient in the feeder route is 250 feet per mile. Where a higher descent gradient is necessary, the **MAXIMUM** permissible gradient is 500 feet per mile. The **OPTIMUM** descent gradient for high altitude penetrations is 800 feet per mile. Where a higher descent gradient is necessary, the **MAXIMUM** permissible is 1,000 feet per mile.

221. MINIMUM SAFE/SECTOR ALTITUDES (MSA). A minimum safe altitude provides at least 1,000 feet of obstacle clearance for emergency use, within a specified distance from the RNAV WP/primary navigation facility upon which a procedure is predicated. Minimum altitudes are identified as minimum safe altitudes or emergency safe altitudes, and are rounded to the next higher 100-foot increment.

a. **MSA.** Establish an MSA for all procedures within a 25-mile radius of the WP/facility, including the area 4

miles beyond the outer boundary. When the distance from the facility to the airport exceeds 25 miles, extend the radius to include the airport landing surfaces up to a maximum distance of 30 miles. See figure 2-1. When the procedure does not use an omnidirectional facility; e.g., LOC BC with a fix for the FAF, use the primary omnidirectional facility in the area. If necessary to offer relief from obstacles, establish sector divisions, or a common safe altitude (no sectors) for the entire area around the facility. Sectors shall not be less than 90° in spread. Sector altitudes should be raised and combined with adjacent higher sectors when the altitude difference does not exceed 300 feet. A sector altitude shall also provide 1,000 feet of obstacle clearance in any adjacent sector within 4 miles of the sector boundary line. For area navigation (RNAV) procedures establish a common safe altitude within the specified radius of the runway waypoint (RWY WP) for straight-in approaches; or the airport waypoint (APT WP) for circling procedures; for GPS approaches, from the WP used for the MSA center (see figure 2-2).

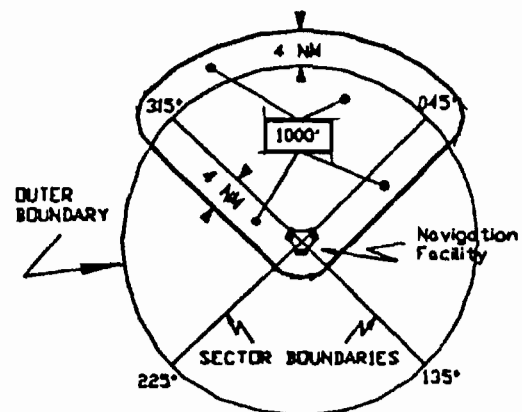

Figure 2-1. Non-RNAV MSA. Par 221.

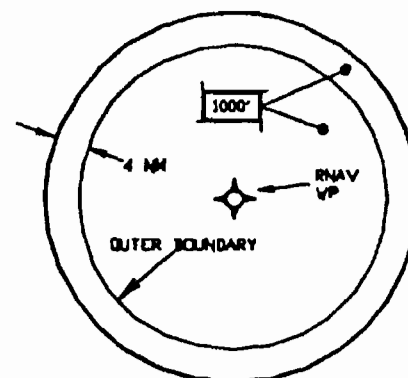

Figure 2-2. RNAV MSA. Par 221.

b. **Emergency Safe Altitudes (ESA).** ESA's are normally developed only for military procedures, and at the option of the approving authority. Establish ESA's within a 100-mile radius of the navigation facility or WP used as the ESA center, with a common altitude for the entire area. Where ESA's are located in designated mountainous areas, provide at least 2,000 feet of obstacle clearance.

222-229. RESERVED.

SECTION 3. INITIAL APPROACH

230. INITIAL APPROACH SEGMENT. The instrument approach commences at the IAF. In the initial approach, the aircraft has departed the en route phase of flight and is maneuvering to enter an intermediate segment. When the IF is part of the en route structure, it may not be necessary to designate an initial approach segment. In this case, the approach commences at the IF and intermediate segment criteria apply. An initial approach may be made along an arc, radial, course, heading, radar vector, or a combination thereof. Procedure turns, holding pattern descents, and high altitude penetrations are initial segments. Positive course guidance (PCG) is required except when dead reckoning (DR) courses can be established over limited distances. Although more than one initial approach may be established for a procedure, the number should be limited to that which is justified by traffic flow or other operational requirements. Where holding is required prior to entering the initial approach segment, the holding fix and IAF should coincide. When this is not possible, the IAF shall be located within the holding pattern on the inbound holding course.

231. ALTITUDE SELECTION. Minimum altitudes in the initial approach segment shall be established in 100-foot increments; i.e., 1,549 feet may be shown as 1,500 feet and 1,550 feet shall be shown as 1,600 feet. The altitude selected shall not be below the PT altitude where a PT is required. In addition, altitudes specified in the initial approach segment must not be lower than any altitude specified for any portion of the intermediate or final approach segment.

232. INITIAL APPROACH SEGMENTS BASED ON STRAIGHT COURSES AND ARCS WITH PCG.

a. Alignment.

(1) **Courses.** The angle of intersection between the initial approach course and the intermediate course shall not exceed 120°. When the angle exceeds 90°, a

radial or bearing which provides at least 2 miles of lead shall be identified to assist in leading the turn onto the intermediate course (see figure 3).

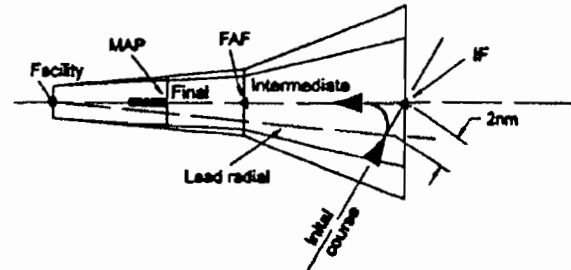

Figure 3. INITIAL APPROACH INTERCEPTION ANGLE GREATER THAN 90°. Par 232a(1).

(2) **Arcs.** An arc may provide course guidance for all or a portion of an initial approach. The minimum arc radius shall be 7 miles, except for high altitude jet penetration procedures, in which the minimum radius should be at least 15 miles. When an arc of less than 15 miles is used in high altitude procedures, the descent gradient along the arc shall not exceed the values in table 1. An arc may join a course at or before the IF. When joining a course at or before the IF, the angle of intersection of the arc and the course shall not exceed 120°. When the angle exceeds 90°, a radial which provides at least 2 miles of lead shall be identified to assist in leading the turn on to the intermediate course. DME arc courses shall be predicated on DME collocated with a facility providing omnidirectional course information.

Table 1. DESCENT GRADIENT ON AN ARC. Par 232a(2).

MILES	MAX FT. PER NM
15	1,000
14	720
13	640
12	560
11	480
10	400
9	320
8	240
7	160

b. **Area.** The initial approach segment has no standard length. The length shall be sufficient to permit the altitude change required by the procedure and shall not exceed 50 miles unless an operational requirement exists. The total width of the initial approach segment shall be 6 miles on each side of the initial approach

course. This width is divided into a primary area, which extends laterally 4 miles on each side of the course, and a secondary area, which extends laterally 2 miles on each side of the primary area. See figure 10. When any portion of the initial approach is more than 50 miles from the navigation facility, the criteria for en route airways shall apply to that portion.

e. **Obstacle Clearance.** The obstacle clearance in the initial approach primary area shall be a minimum of 1,000 feet. In the secondary area 500 feet of obstacle clearance shall be provided at the inner edge, tapering uniformly to zero feet at the outer edge.

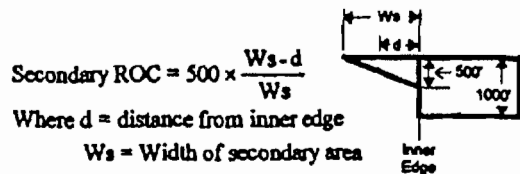

Allowance for precipitous terrain should be made as specified in paragraph 323a. The altitudes selected by application of the obstacle clearance specified in this paragraph may be rounded to nearest 100 feet. See paragraph 231.

d. **Descent Gradient.** The OPTIMUM descent gradient in the initial approach is 250 feet per mile. Where a higher descent gradient is necessary, the MAXIMUM gradient is 500 feet per mile. The OPTIMUM descent gradient for high altitude penetrations is 800 feet per mile. Where a higher descent gradient is necessary, the MAXIMUM gradient is 1,000 feet per mile.

233. INITIAL APPROACH SEGMENT BASED ON DR. See ILS Chapter for special limitations.

a. **Alignment.** Each DR course shall intercept the extended intermediate course. For LOW altitude procedures, the intercept point shall be at least 1 mile from the IF for each 2 miles of DR flown. For HIGH altitude procedures, the intercept point may be 1 mile for each 3 miles of DR flown. The intercept angle shall:

(1) Not exceed 90°

(2) Not be less than 45° except when DME is used OR the DR distance is 3 miles or less.

b. **Area.** The MAXIMUM length of the DR portion of the initial segment is 10 miles (except paragraph 232b applies for HIGH altitude procedures where DME is available throughout the DR segment). Where the DR course begins, the width is 6 miles on each side of

the course, expanding by 15° outward until joining the points shown in figures 4-1, 4-2, 4-3, 4-4, and 4-5.

e. **Obstacle Clearance.** The obstacle clearance in the DR initial approach segment shall be a minimum of 1,000 feet. There is no secondary area. Allowance for precipitous terrain should be considered as specified in paragraph 323a. The altitudes selected by application of the obstacle clearance specified in this paragraph may be rounded to the nearest 100 feet (see paragraph 231).

d. **Descent Gradient.** The OPTIMUM descent gradient in the initial approach is 250 feet per mile. Where a higher descent gradient is necessary, the MAXIMUM permissible gradient is 500 feet per mile. The OPTIMUM descent gradient for high altitude penetrations is 800 feet per mile. Where a higher descent gradient is necessary, the MAXIMUM permissible gradient is 1,000 feet per mile.

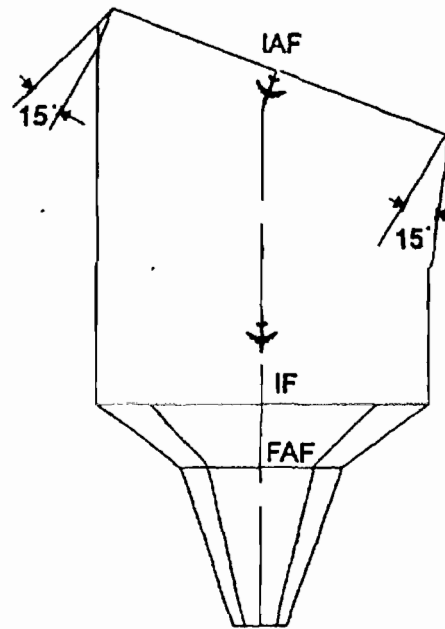

Figure 4-1. MOST COMMON DR SEGMENT. Par 233b.

Policy Memo Dec 28 2007

Policy Memo Dec 28 2007

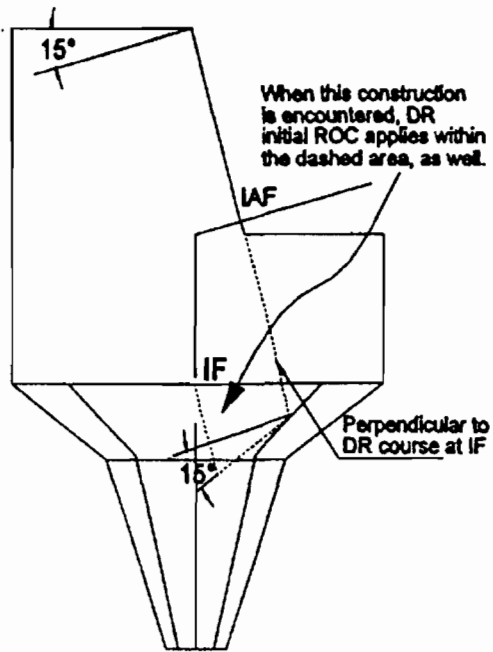

Figure 4-2. DR SEGMENT WITH BOUNDARY INSIDE THE INTERMEDIATE SEGMENT. Par 233b.

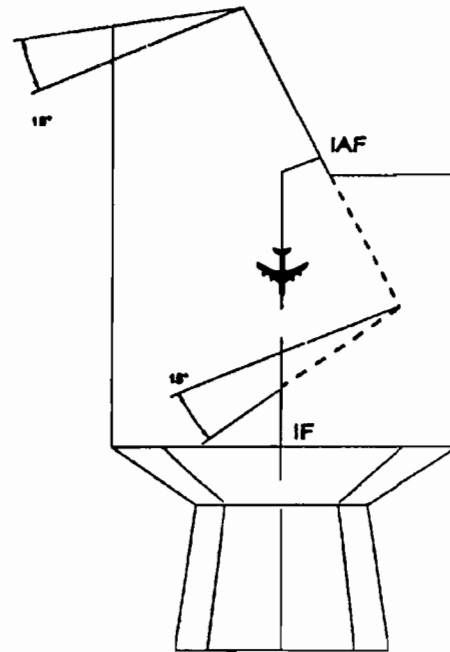

Figure 4-4. DR INITIAL SEGMENT WITH BOUNDARY INSIDE THE STRAIGHT INITIAL SEGMENT. Par 233b.

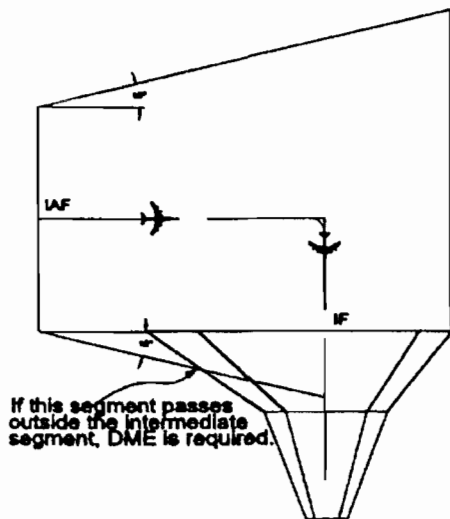

Figure 4-3. DR SEGMENT WITH BOUNDARY INTERCEPTING THE INTERMEDIATE SEGMENT. Par 233b.

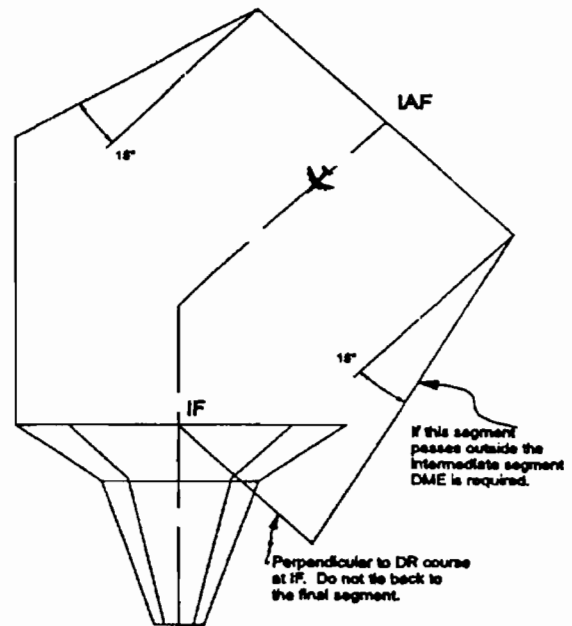

Figure 4-5. DR INITIAL SEGMENT WITH BOUNDARY OUTSIDE THE INTERMEDIATE SEGMENT. Par 233b.

234. INITIAL APPROACH SEGMENT BASED ON A PT. A PT shall be specified when it is necessary to reverse direction to establish the aircraft on an intermediate or FAC, except as specified in paragraph 234c. A PT begins by overheading a facility or fix which meets the criteria for a holding fix (see paragraph 287b), or for a FAF (see paragraph 287c). The procedure shall specify the PT fix, the outbound and inbound course, the distance within which the PT shall be completed, and the direction of the PT. When a teardrop turn is used, the angle of divergence between the outbound courses and the reciprocal of the inbound course shall be a MINIMUM of 15° or a MAXIMUM of 30° (see paragraph 235a for high altitude teardrop penetrations). When the beginning of the intermediate or final approach segment associated with the procedure turn is not marked by a fix, the segment is deemed to begin on the inbound procedure turn course at the maximum distance specified in the procedure. Where neither segment is marked by a fix, the final segment begins at the maximum distance specified in the procedure.

a. Alignment. When the inbound course of the PT becomes the intermediate course, it must meet the intermediate course alignment criteria (see paragraph 242a). When the inbound course becomes the

FAC, it must meet the FAC alignment criteria (see paragraph 250). The wider side of the PT area shall be oriented in the same direction as that prescribed for the PT.

b. Area. The PT areas are depicted in figure 5. The normal PT distance is 10 miles. See table 1A. Decrease this distance to 5 miles where only CAT A aircraft or helicopters are to be operating, and increase to 15 miles to accommodate operational requirements, or as specified in paragraph 234d. No extension of the PT is permitted without a FAF. When a PT is authorized for use by approach CAT E aircraft, use a 15-mile PT distance. The PT segment is made up of the entry and maneuvering zones. The entry zone terminates at the inner boundary which extends perpendicular to the PT inbound course at the PT fix. The remainder of the PT segment is the maneuvering zone. The entry and maneuvering zones are made up of primary and secondary areas. The PT primary area dimensions are based on the PT completion altitude or the highest feeder route altitude, whichever is greater. To allow additional maneuvering area as the true airspeed increases at higher altitudes, the dimensions of the PT primary area increase. The PT secondary area is 2 miles on the outside of the primary area.

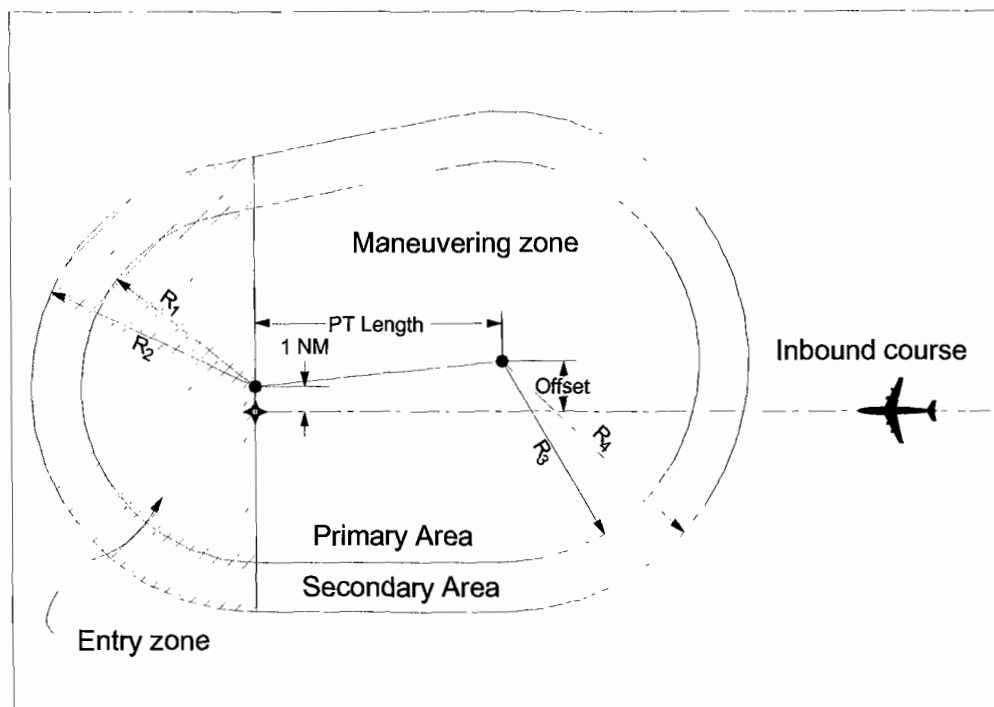

Figure 5. PROCEDURE TURN AREA, Par 234b.
(See Table 1A to determine radius values.)

Table 1A, PROCEDURE TURN VARIABLES ACCORDING TO ALTITUDE, Par 234b.

≤6,000

PT Length	Offset	R ₁	R ₂	R ₃	R ₄
5	2	4	6	5	7
>5-10	2	5	7	6	8
>10-15	β-4	5	7	β	β+2

$$\beta = 0.1 \times (d - 10) + 6$$

Where d = PT Length

>6,000 ≤10,000

PT Length	Offset	R ₁	R ₂	R ₃	R ₄
5	2	4	6	5	7
>5-10	2	6	8	7	9
>10-15	β-5	6	8	β	β+2

$$\beta = 0.1 \times (d - 10) + 7$$

Where d = PT Length

>10,000

PT Length	Offset	R ₁	R ₂	R ₃	R ₄
5	2	4	6	5	7
>5-10	2	7	9	8	10
>10-15	β-6	7	9	β	β+2

$$\beta = 0.1 \times (d - 10) + 8$$

Where d = PT Length

feet at the outer edge (see figure 6). Allowance for precipitous terrain should be considered as specified in paragraph 323a. The primary and secondary areas determine obstacle clearance in both the entry and maneuvering zones. The use of entry and maneuvering zones provides further relief from obstacles. The entry zone is established to control the obstacle clearance prior to proceeding outbound from the PT fix. The maneuvering zone is established to control obstacle clearance AFTER proceeding outbound from the PT fix (see figure 5). The altitudes selected by application of the obstacle clearance as specified in this paragraph may be rounded to the nearest 100 feet (see paragraph 231).

$$\text{Secondary ROC} = 500 \times \frac{W_s - d}{W_s}$$

Where d = distance from inner edge

W_s = Width of secondary area

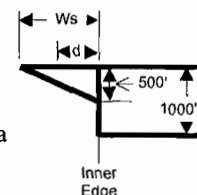

d. Descent Gradient. The OPTIMUM descent gradient in the initial approach is 250 feet per mile. Where a higher descent gradient is necessary, the MAXIMUM permissible gradient is 500 feet per mile. Where a PT is established over a FAF, the PT completion altitude should be as close as possible to the FAF altitude. The difference between the PT completion altitude and the altitude over the FAF shall not be greater than those shown in table 1B. If greater differences are required for a 5- or 10-mile PT, the PT distance limits and maneuvering zone shall be increased at the rate of 1 mile for each 200 feet of required altitude.

c. Obstacle Clearance. A minimum of 1,000 feet of clearance shall be provided in the primary area. In the secondary area, 500 feet of obstacle clearance shall be provided at the inner edge, tapering uniformly to zero

Policy Memo
Dec 28 2007

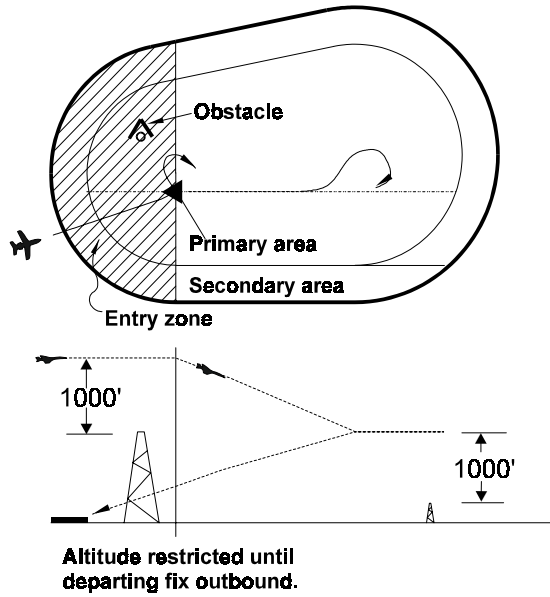

Figure 6. PT INITIAL APPROACH AREA. Par 234c.

e. Elimination of PT. A PT is NOT required when an approach can be made direct from a specified IF to the FAF. A PT NEED NOT be established when an approach can be made from a properly aligned holding pattern. See paragraph 291. In this case, the holding pattern in lieu of a PT, shall be established over a final or intermediate approach fix and the following conditions apply:

(1) If the holding pattern is established over the FAF (not applicable to RNAV procedures), an intermediate segment is not constructed. Ideally, establish the minimum holding altitude at the FAF altitude. In any case, the published holding altitude shall not be more than 300 feet above the FAF altitude.

(2) If the holding pattern is established over the IF, the MHA shall permit descent to the FAF altitude within the descent gradient tolerances prescribed for the intermediate segment (see paragraph 242d).

Table 1B. PT COMPLETION ALTITUDE DIFFERENCE. Par 234d.

TYPE OF PT	ALTITUDE DIFFERENCE
15 Mile PT from FAF	Within 3,000 Ft of Alt. over FAF
10 Mile PT from FAF	Within 2,000 Ft of Alt. over FAF
5 Mile PT from FAF	Within 1,000 Ft of Alt. over FAF
15 Mile PT, no FAF	Not Authorized
10 Mile PT, no FAF	Within 1,500 Ft of MDA on Final
5 Mile PT, no FAF	Within 1,000 Ft of MDA on Final

235. INITIAL APPROACH BASED ON HIGH ALTITUDE TEARDROP PENETRATION

A teardrop penetration consists of departure from an IAF on an outbound course, followed by a turn toward and intercepting the inbound course at or prior to the IF or point. Its purpose is to permit an aircraft to reverse direction and lose considerable altitude within reasonably limited airspace. Where no IF is available to mark the beginning of the intermediate segment, it shall be assumed to commence at a point 10 miles prior to the FAF. When the facility is located on the airport, and no fix is available to mark the beginning of the final approach segment, the criteria in paragraph 423 apply.

a. Alignment. The outbound penetration course shall be between 18° and 26° to the left or right of the reciprocal of the inbound course. The actual angular divergence between the courses will vary inversely with the distance from the facility at which the turn is made (see table 2).

b. Area.

(1) Size. The size of the penetration turn area must be sufficient to accommodate both the turn and the altitude loss required by the procedure. The penetration turn distance shall not be less than 20 miles from the facility. The penetration turn distance depends on the altitude to be lost in the procedure and the point at which the descent is started (see table 2). The aircraft should lose half the total altitude or 5,000 feet, whichever is greater, outbound prior to starting the turn. The penetration turn area has a width of 6 miles on both sides of the flight track up to the IF or point, and shall encompass all the areas within the turn (see figure 7).

Table 2. PENETRATION TURN DISTANCE/DIVERGENCE. Par 235a.

ALT TO BE LOST PRIOR TO COMMENCING TURN	DISTANCE TURN COMMENCES (NM)	COURSE DIVERGENCE (DEGREES)	SPECIFIED PENETRATION TURN DISTANCE (NM)
12,000 Ft	24	18	28
11,000 Ft	23	19	27
10,000 Ft	22	20	26
9,000 Ft	21	21	25
8,000 Ft	20	22	24
7,000 Ft	19	23	23
6,000 Ft	18	24	22
5,000 Ft	17	25	21
5,000 Ft	16	26	20

(2) Penetration Turn Table. Table 2 should be used to compute the desired course divergence and penetration turn distances which apply when a specific

THIS PAGE INTENTIONALLY LEFT BLANK

altitude loss outbound is required. It is assumed that the descent begins at the plotted position of fix. When the procedure requires a delay before descent of more than 5 miles, the distance in excess of 5 miles should be added to the distance the turn commences. The course divergence and penetration turn distance should then be adjusted to correspond to the adjusted turn distance. Extrapolations may be made from the table.

(3) **Primary and Secondary Areas.** All of the penetration turns area, except the outer 2 miles of the 6-mile obstacle clearance area on the outer side of the penetration track, is primary area. See figure 7. The outer 2 miles is secondary area. The outer 2 miles on both sides of the inbound penetration course should be treated as secondary area.

c. **Obstacle Clearance.** Obstacle clearance in the initial approach primary area shall be a MINIMUM of 1,000 feet. Obstacle clearance at the inner edge of the secondary area shall be 500 feet, tapering to zero feet at the outer edge.

$$\text{Secondary ROC} = 500 \times \frac{W_s - d}{W_s}$$

Where d = distance from inner edge
 W_s = Width of secondary area

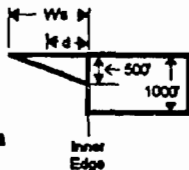

Where no IF is available, a 10 NM intermediate segment is assumed and intermediate segment required obstacle clearance (ROC) is applied. The controlling obstacle, as well as the minimum altitude selected for the intermediate segment, may depend on the availability of an IF. See figure 8. Allowance for precipitous terrain should be considered in the penetration turn area as specified in paragraph 323a. The altitudes selected by application of the obstacle clearance specified in this paragraph may be rounded to the nearest 100 feet. See paragraph 231.

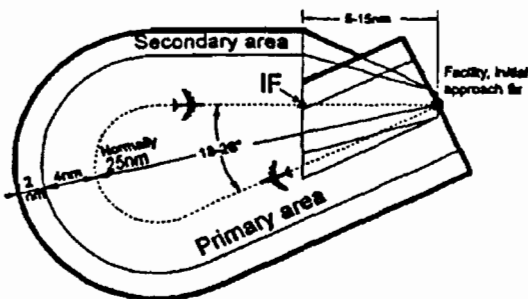

Figure 7. TYPICAL PENETRATION TURN INITIAL APPROACH AREA. Par 235.

d. **Descent Gradient.** The OPTIMUM descent gradient is 800 feet per mile. The MAXIMUM gradient is 1,000 feet per mile.

e. **Penetration Turn Altitude.** When an IF is NOT provided, the penetration turn completion altitude shall not be more than 4,000 feet above the FAF altitude.

236. INITIAL APPROACH COURSE REVERSAL USING NONCOLLOCATED FACILITIES AND A TURN OF 120° OR GREATER TO INTERCEPT THE INBOUND COURSE. See figures 9-1, 9-2 and 9-3.

a. **Common Criteria.**

(1) A turn point fix shall be established as shown in the figures. The fix error shall meet section 8 criteria and shall not exceed ± 2 NM.

(2) A flightpath radius of 2.8 NM shall be used for procedures where the altitude at the turn point fix is at or before 10,000 feet, or 4 NM for procedures where the altitude at the turn point fix is above 10,000 feet MSL.

(3) **Descent Gradient.** Paragraph 232d applies.

(4) **Obstacle Clearance.** Paragraph 235c applies.

(5) **Initial Distance.** When the course reversal turn intercepts the extended intermediate course, and when the course reversal turn intercepts a straight segment prior to intercepting the extended intermediate course, the minimum distance between the rollout point and the FAF is 10 NM.

(6) **ROC Reduction.** No reduction of secondary ROC is authorized in the course reversal area unless the turn point fix is DME.

b. **Figures 9-1 and 9-2.** The rollout point shall be at or prior to the IF/point.

(1) Select the desired rollout point on the inbound course.

(2) Place the appropriate flightpath arc tangent to the rollout point.

(3) From the outbound facility, place the outbound course tangent to the flightpath arc. The point of tangency shall be the turn point fix.

Policy Memo
 Dec 28 2007

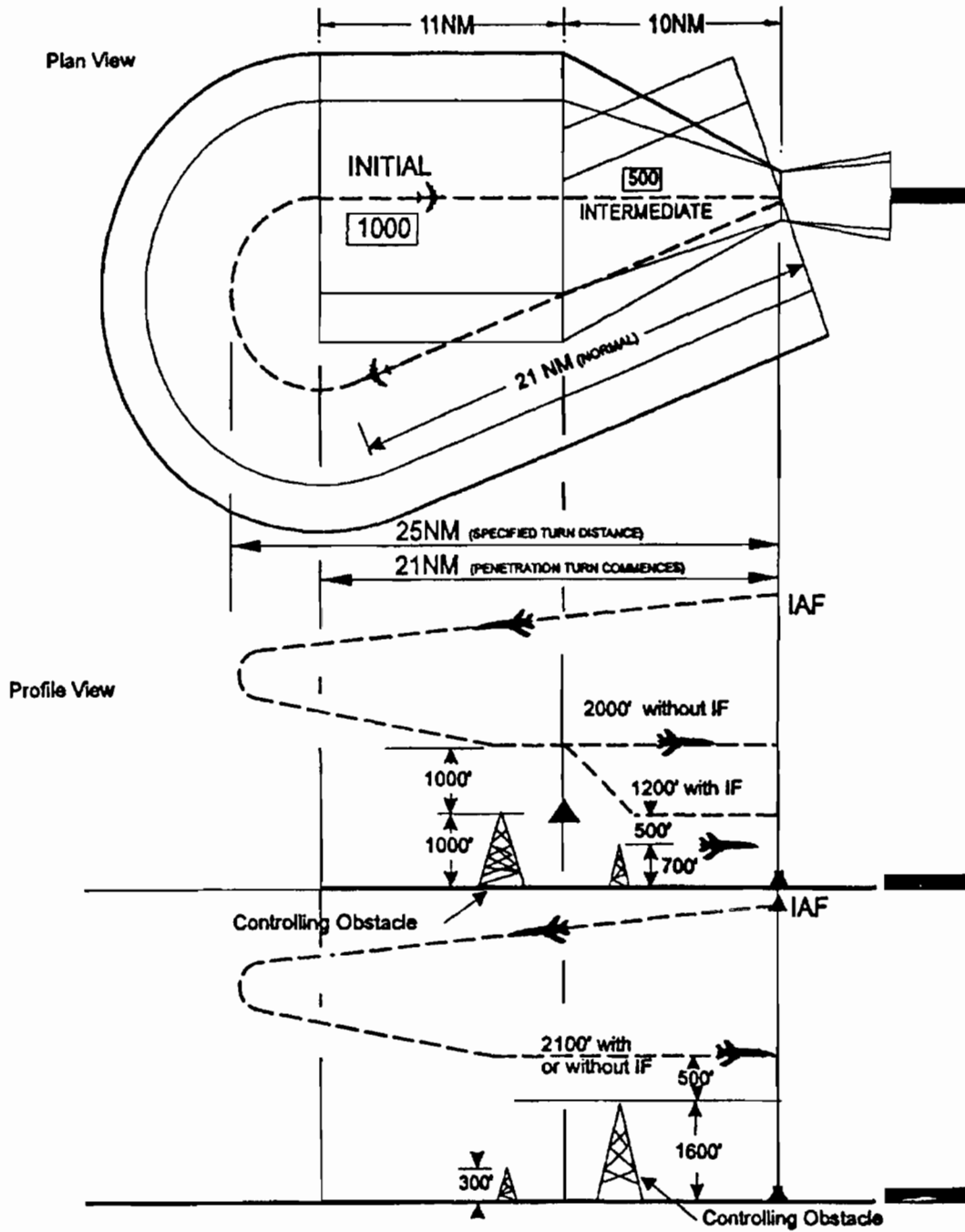
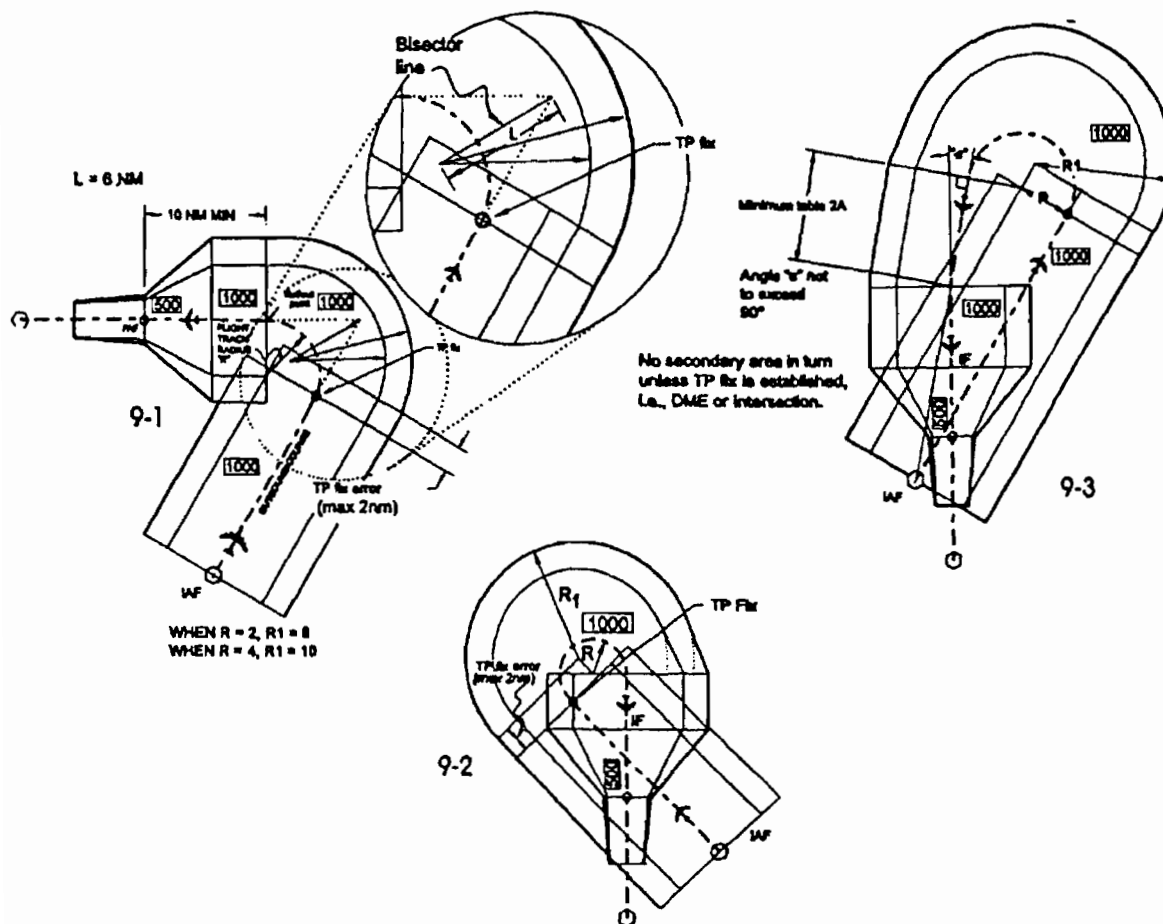

Figure 8. PENETRATION TURN INITIAL APPROACH OBSTACLE CLEARANCE. Par 235c.



Figures 9-1, 9-2, and 9-3. EXAMPLES OF INITIAL APPROACH COURSE REVERSAL. Par 236.

c. Figure 9-3

(1) The point of intersection shall be at or prior to the IF/point (paragraph 242 applies). The angle shall be 90° or less.

(2) The distance between the roll-out point and the point of intersection shall be no less than the distance shown in table 2A.

(3) Paragraph 235 and table 2 should be used for high altitude procedures up to the point of intersection of the two inbound courses.

Table 2A. MINIMUM DISTANCE FROM ROLL OUT POINT TO POINT OF INTERSECTION. Par. 236c(2).

ANGLE "a" (DEGREES)	NM
0 - 15	1
>15 - 30	2
>30 - 45	3
>45 - 60	4
>60 - 75	5
>75 - 90	6

(4) Select the desired point of intersection.

From the outbound facility draw a line through the point of intersection.

(5) At the outbound facility, measure the required number of degrees course divergence (may be either side of the line through the point of intersection) and draw the outbound course out the required distance. Connect the outbound course and the line through the point of intersection with the appropriate arc.

(6) Determine the desired rollout point on the line through the point of intersection.

(a) Place the appropriate flightpath arc tangent to the rollout point.

(b) From the outbound facility draw the outbound course tangent to the flightpath arc. The point of tangency is the turn point fix.

237.-239. RESERVED.

SECTION 4. INTERMEDIATE APPROACHES**240. INTERMEDIATE APPROACH SEGMENT.**

This is the segment which blends the initial approach segment into the final approach segment. It is the segment in which aircraft configuration, speed, and positioning adjustments are made for entry into the final approach segment. The intermediate segment begins at the IF, or point, and ends at the FAF. There are two types of intermediate segments; the "radial" or "course" intermediate segment and the "arc" intermediate segment. In either case, PCG shall be provided. See figure 10 for typical approach segments.

241. ALTITUDE SELECTION. The MINIMUM altitude in the intermediate segment shall be established in 100-foot increments; i.e., 749 feet may be shown as 700 feet and 750 feet shall be shown as 800. In addition, the altitude selected for arrival over the FAF shall be low enough to permit descent from the FAF to the airport for a straight-in landing whenever possible.

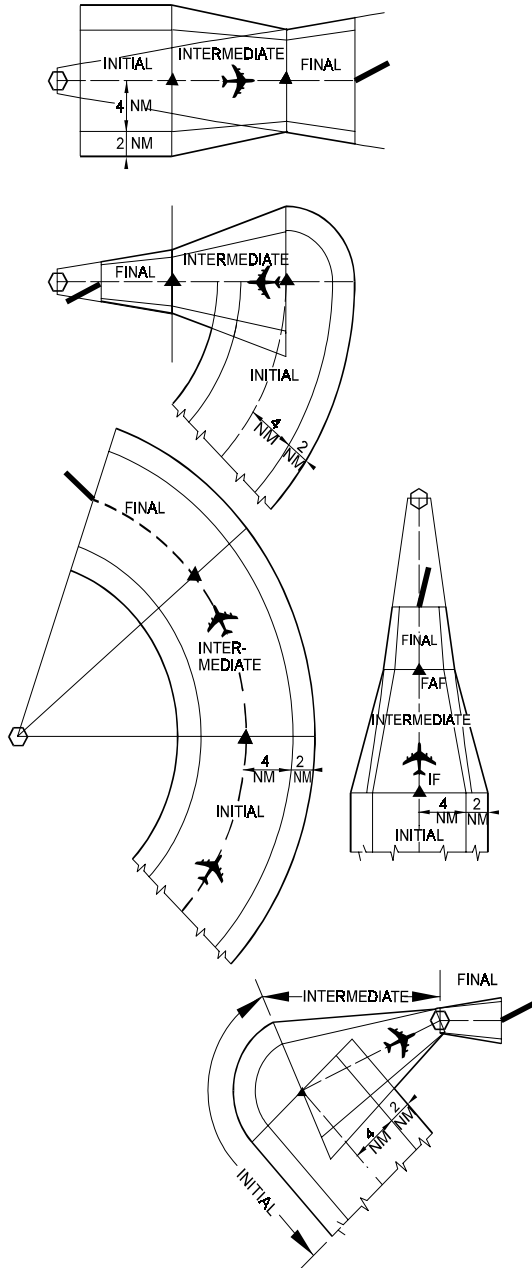

Figure 10. TYPICAL APPROACH SEGMENTS.
Par 232b and 240.

242. INTERMEDIATE APPROACH SEGMENT BASED ON STRAIGHT COURSES.

a. Alignment. The course to be flown in the intermediate segment shall be the same as the FAC, except when the FAF is the navigation facility and it is not practical for the courses to be identical. In such cases, the intermediate course shall not differ from the FAC by more than 30°.

b. Area.

(1) Length. The length of the intermediate segment is measured along the course to be flown. Where the initial segment joins the intermediate segment at angles up to 90 degrees, the MINIMUM length is 5 NM for CAT A/B, and 6 NM for CAT C/D/E (except as specified in Volume 1, chapters 9 and 10, and Volume 3, chapter 2). Table 3 lists the minimum segment length where the initial approach course joins the intermediate course at an angle greater than 90 degrees (see figure 3). The MAXIMUM segment length is 15 NM. The OPTIMUM length is 10 NM. A distance greater than 10 NM should not be used unless an operational requirement justifies a greater distance.

(2) Width. The width of the intermediate segment is the same as the width of the segment it joins. When the intermediate segment is aligned with initial or final approach segments, the width of the intermediate segment is determined by joining the outer edges of the initial segment with the outer edges of the final segment. When the intermediate segment is not aligned with the initial or final approach segments, the resulting gap on the outside of the turn is a part of the preceding segment and is closed by the appropriate arc (See figure 10). For obstacle clearance purposes, the intermediate segment is divided into a primary and a secondary area.

Table 3. MINIMUM INTERMEDIATE COURSE LENGTH. Par 242b(1).

ANGLE (DEGREES)	MINIMUM LENGTH (MILES)	
	Cat A/B	C/D/E
>90 - 96	5	6
>96 - 102	6	7
>102 - 108	6	8
>108 - 114	6	9
>114 - 120	7	10

c. Obstacle Clearance. A MINIMUM of 500 feet of obstacle clearance shall be provided in the primary area of the intermediate approach segment. In the secondary area, 500 feet of obstacle clearance shall be provided at the inner edge, tapering to zero feet at the outer edge.

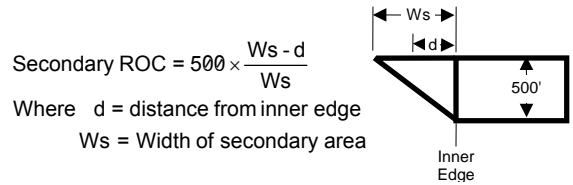

$$\text{Secondary ROC} = 500 \times \frac{Ws - d}{Ws}$$

Where d = distance from inner edge
Ws = Width of secondary area

Allowance for precipitous terrain should be considered as specified in paragraph 323a. The altitudes selected

Policy
Memo
Dec 28
2007

by application of the obstacle clearance specified in this paragraph may be rounded to the nearest 100 feet (see paragraph 241).

d. Descent Gradients. Because the intermediate segment is used to prepare the aircraft speed and configuration for entry into the final approach segment, the gradient should be as flat as possible. The OPTIMUM descent gradient is 150 feet per mile. The MAXIMUM gradient is 318 feet per mile, except for a localizer approach published in conjunction with an ILS procedure. In this case, a higher descent gradient equal to the commissioned GS angle (provided it does not exceed 3°) is permissible. Higher gradients resulting from arithmetic rounding are also permissible.

NOTE: When the descent gradient exceeds 318 feet per mile, the procedure specialist should assure a segment is provided prior to the intermediate segment to prepare the aircraft speed and configuration for entry into the final segment. This segment should be a minimum length of 5 miles and its descent gradient should not exceed 318 feet per mile.

243. INTERMEDIATE APPROACH SEGMENT BASED ON AN ARC. Arcs with a radius of less than 7 miles or more than 30 miles from the navigation facility shall NOT be used. DME arc courses shall be predicated on DME collocated with a facility providing omnidirectional course information.

a. Alignment. The same arc shall be used for the intermediate and the final approach segments. No turns shall be required over the FAF.

b. Area.

(1) Length. The intermediate segment shall NOT be less than 5 miles nor more than 15 miles in length, measured along the arc. The OPTIMUM length is 10 miles. A distance greater than 10 miles should not be used unless an operational requirement justifies the greater distance.

(2) Width. The total width of an arc intermediate segment is 6 miles on each side of the arc. For obstacle clearance purposes, this width is divided into a primary and a secondary area. The primary area extends 4 miles laterally on each side of the arc segment. The secondary areas extend 2 miles laterally on each side of the primary area (see figure 10).

c. Obstacle Clearance. A MINIMUM of 500 feet of obstacle clearance shall be provided in the primary area. In the secondary area, 500 feet of obstacle

clearance shall be provided at the inner edge, tapering to zero feet at the outer edge.

$$\text{Secondary ROC} = 500 \times \frac{W_s - d}{W_s}$$

Where d = distance from inner edge

W_s = Width of secondary area

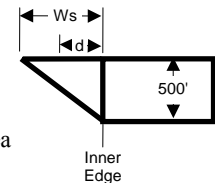

Allowance for precipitous terrain should be considered as specified in paragraph 323a. The altitudes selected by application of the obstacle clearance specified in this paragraph may be rounded to the nearest 100 feet (see paragraph 241).

d. Descent Gradients. Criteria specified in paragraph 242d shall apply.

244. INTERMEDIATE APPROACH SEGMENT WITHIN A PT.

a. PT Over a FAF. When the FAF is a facility (see figure 11).

(1) The MAXIMUM intermediate length is 15 NM, the OPTIMUM is 10 NM, and the MINIMUM is 5 NM. Its width is the same as the final segment at the facility and expanding uniformly to 6 NM on each side of the course at 15 NM from the facility.

(2) The intermediate segment considered for obstacle clearance shall be the same length as the PT distance; e.g., if the procedure requires a PT to be completed within 5 NM, the intermediate segment shall be only 5 NM long, and the intermediate approach shall begin on the intermediate course 5 NM from the FAF.

(3) When establishing a stepdown fix within an intermediate/initial segment underlying a PT area:

(a) Table 1A shall be applied.

(b) Only one stepdown fix is authorized within the intermediate segment that underlies the PT maneuvering area.

(c) The distance between the PT fix/facility and a stepdown fix underlying the PT area shall not exceed 4 NM.

(d) The MAXIMUM descent gradient from the IF point to the stepdown fix is 200 feet/NM. The MAXIMUM descent gradient from the stepdown fix to the FAF is 318 feet/NM.

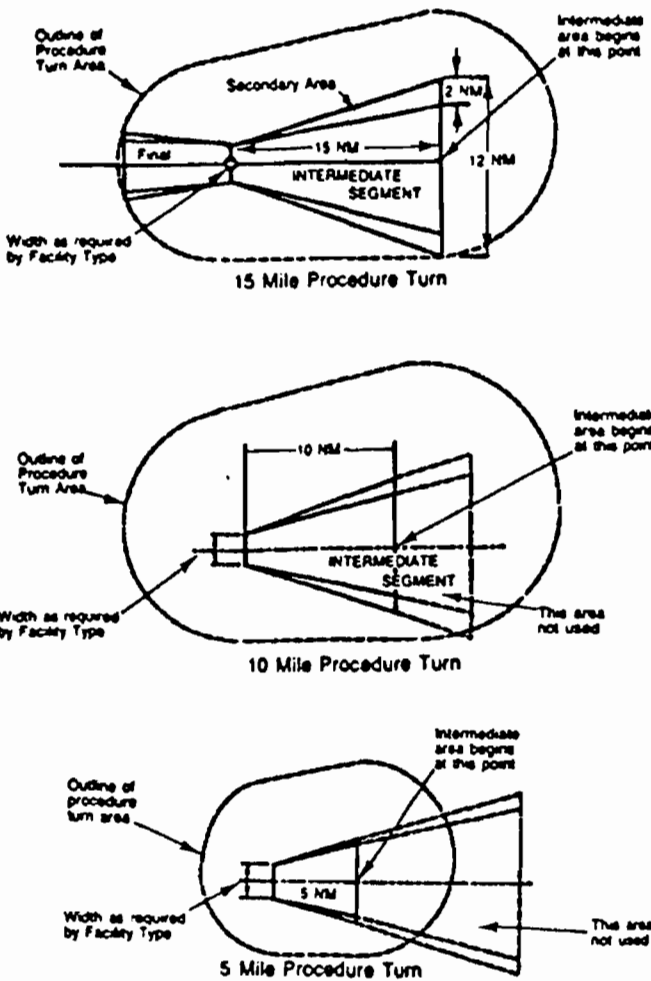

Figure 11. INTERMEDIATE AREA WITHIN A PT AREA. FAF is the Facility. Par 244a.

b. PT Over a FAF when the FAF is NOT a Facility (See figure 12).

(1) The intermediate segment shall be 6 NM wide each side of the intermediate course at the PT distance.

(2) When establishing a stepdown fix within an intermediate/initial segment underlying a PT area:

(a) Table 1A shall be applied.

(b) Only one stepdown fix is authorized within the intermediate segment that underlies the PT maneuvering area.

(c) The distance between the PT fix/facility and a stepdown fix underlying the PT area shall not exceed 4 NM.

(d) The MAXIMUM descent gradient from the IF point to the stepdown fix is 200 feet/NM. The MAXIMUM descent gradient from the stepdown fix to the FAF is 318 feet/NM.

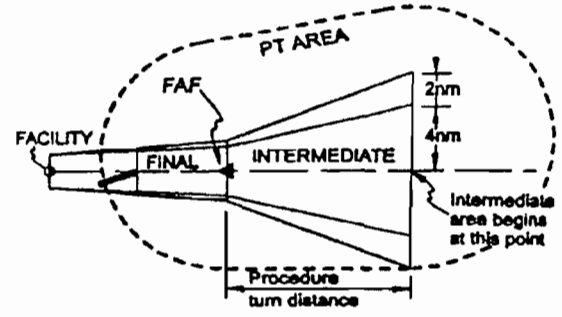

Figure 12. INTERMEDIATE AREA WITHIN THE PT AREA. FAF is not the Facility. Par 244b.

c. PT Over a Facility/Fix AFTER the FAF. See figure 13.

(1) The PT facility/fix to FAF distance shall not exceed 4 NM.

(2) The MAXIMUM PT distance is 15 NM.

(3) The length of the intermediate segment is from the start of the PT distance to the FAF and the MINIMUM length shall be 5 NM.

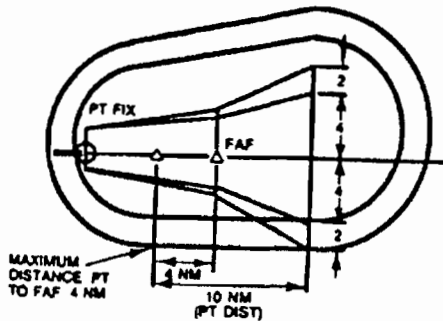
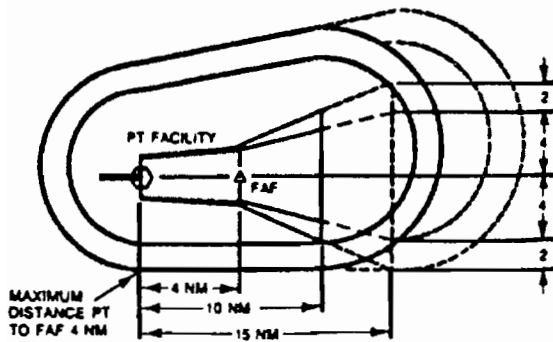

Figure 13. INTERMEDIATE AREA WITHIN THE PT AREA. PT Over the Facility/Fix After the FAF. Par 244c.

(4) Intermediate Segment Area.

(a) PT Over a Facility. The intermediate segment starts 15 NM from the facility at a width of 6 NM each side of the inbound course and connects to the width of the final segment at the FAF. The area considered for obstacle clearance is from the start of the PT distance to the FAF.

(b) PT Over a Fix (NOT a Facility). The intermediate segment starts at the PT distance at a width of 6 NM each side of the inbound course and connects to the width of the final segment at the FAF. The area considered for obstacle clearance is from the start of the PT distance to the FAF.

(5) The MAXIMUM descent gradient in the intermediate segment is 200 feet/NM. The PT distance may be increased in 1 NM increments up to 15 NM to meet descent limitations.

(6) When establishing a stepdown fix within an intermediate/initial segment underlying a PT area:

(a) Only one stepdown fix is authorized within the intermediate segment that underlies the PT maneuvering area.

(b) The distance between the PT fix/facility and a stepdown fix underlying the PT area shall not exceed 4 NM.

(c) The MAXIMUM descent gradient from the IF point to the stepdown fix is 200 feet/NM. The MAXIMUM descent gradient from the stepdown fix to the FAF is 318 feet/NM.

d. PT Over a Facility/Fix PRIOR to the FAF. See figures 14-1 and 14-2.

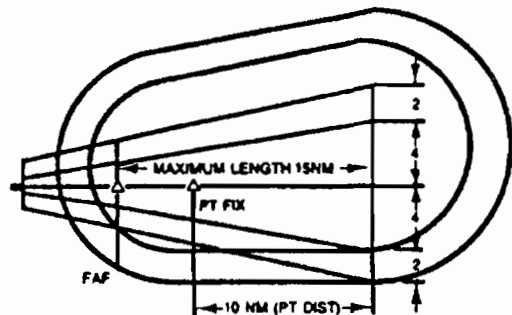
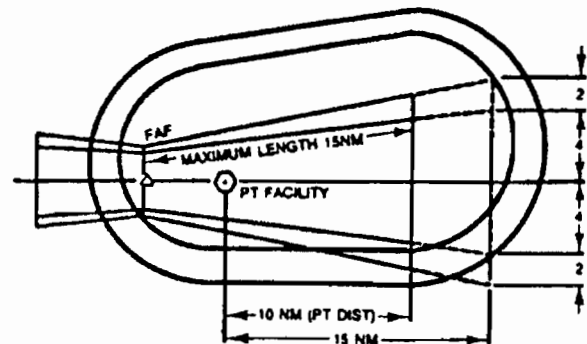

Figure 14-1. INTERMEDIATE AREA WITHIN THE PT AREA. PT Over the Facility/Fix Prior to the FAF. Par 244d.

(1) The MINIMUM PT distance is 5 NM.

(2) The length of the intermediate segment is from the start of the PT distance to the FAF and the MAXIMUM length is 15 NM.

(3) Intermediate Segment Area.

(a) **PT Over a Facility.** The intermediate segment starts 15 NM from the facility at a width of 6 NM each side of the inbound course and connects to the width of the final segment at the FAF. The area considered for obstacle clearance is from the start of the PT distance to the FAF.

Figure 14-2. Intermediate Area Within PT Area. PT Facility/Fix Used as a Stepdown Fix [Par 244d(4)].

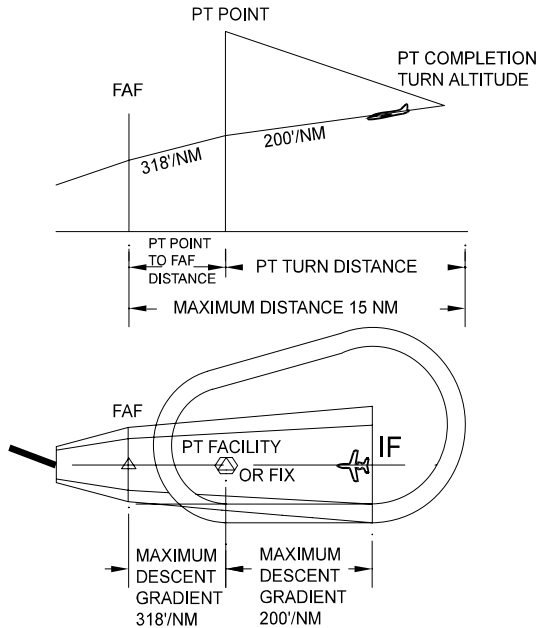

(b) **PT Over a Fix (NOT a Facility).** The intermediate segment starts at the PT distance at a width of 6 NM each side of the inbound course and connects to the width of the final segment at the FAF. The area considered for obstacle clearance is from the start of the PT distance to the FAF.

(4) The MAXIMUM descent gradient is 200 ft/NM. If the PT facility/fix is a stepdown fix, the descent gradient from the stepdown fix to the FAF may be increased to a maximum of 318 ft/NM (see figure 14-2). The PT distance may be increased in 1 NM increments up to 15 NM to meet descent limitations.

(5) When establishing a step-down fix within an intermediate/initial segment underlying a PT area:

(a) When the PT fix is over a facility/fix prior to the FAF, the facility/fix is the stepdown fix in

the intermediate/initial area, and another stepdown fix within this segment is not authorized.

(b) The MAXIMUM descent gradient from the IF point to the stepdown fix is 200 ft/NM. The MAXIMUM descent gradient from the stepdown fix to the FAF is 318 ft/NM.

e. PT Facility Fix Used as an IF. See figure 14-3.

(1) When the PT inbound course is the same as the intermediate course, either paragraph 244d may be used, or a straight initial segment may be used from the start of the PT distance to the PT fix.

Figure 14-3. Use of PT Fix or IF [Par 244e].

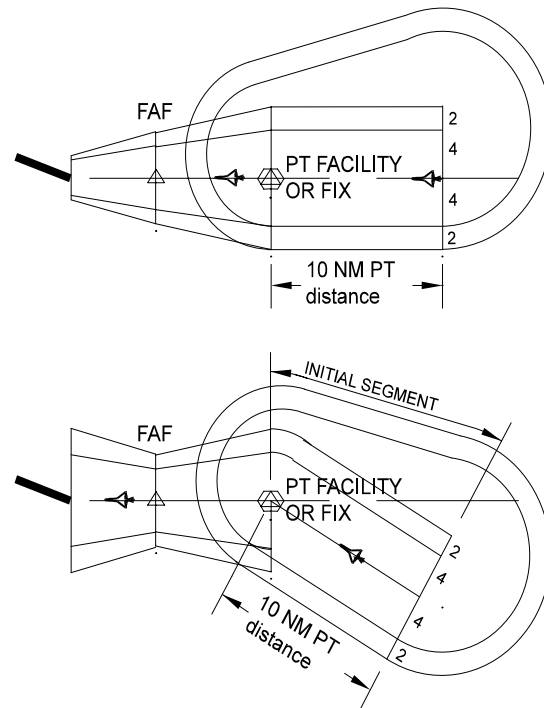

(2) When the PT inbound course is NOT the same as the intermediate course, an intermediate segment within the PT area is NOT authorized; ONLY a straight initial segment shall be used from the start of the PT distance to the PT fix.

(3) When a straight initial segment is used, the MAXIMUM descent gradient within the PT distance is 318 ft/NM; the PT distance may be increased in 1 NM increments up to 15 NM to meet descent limitations.

(4) When establishing a step-down fix within an intermediate/initial segment underlying a PT area:

(a) Only one stepdown fix is authorized within the initial segment that underlies the PT maneuvering area.

(b) The distance from the PT facility/fix and a stepdown fix underlying the PT area shall not exceed 4 nautical miles (NM).

(c) The MAXIMUM descent gradient from the PT completion point (turn distance) to the stepdown fix, and from the stepdown fix to the IF, is 318 ft/NM.

f. **When a PT from a facility** is required to intercept a localizer course, the PT facility is considered on the localizer course when it is located within the commissioned localizer course width.

245.-249. RESERVED.

SECTION 5. FINAL APPROACH

250. FINAL APPROACH SEGMENT. This is the segment in which alignment and descent for landing are accomplished. Final approach may be made to a runway for a straight-in landing or to an airport for a circling approach. The segment begins at the Final Approach Fix (FAF)/precise final approach fix (PFAF) and ends at the missed approach point (MAP) and/or Decision Altitude (DA). Criteria for alignment, length, obstacle evaluation area (OEA), and obstacle clearance surface/evaluation are contained in the chapters/directives specific to the facility/system providing navigation guidance. A visual portion within the final approach segment is also assessed for all approaches (see Vol. 1, chapter 3, paragraph 3.3.2d).

251. RESERVED.

252. VERTICAL DESCENT ANGLE. Vertical descent angle (VDA) is normally used in this segment for non-precision procedures. Determine the VDA for all NPA procedures except those published in conjunction with vertically-guided minima or no-FAF procedures w/out stepdown fix(es). See applicable chapters/directives for guidance on no-FAF or procedures published with PA and APV minima. Optimum VDA is 3.00 degrees. Where operationally feasible, design straight-in NPA procedures (all CATs) to achieve a VDA equal to the commissioned angle of an installed visual glideslope indicator (VGSI) if within the standard VDA range. When a VGSI is not installed or not within the standard range, or final is circling aligned, design procedures at the optimum VDA when possible or within the following range:

STANDARD VERTICAL DESCENT ANGLES		
FAA	2.75°-3.77°	(IAPS w/ ≤ CAT C mins)
	2.75°-3.50°	(IAPS w/ CAT D/E mins)
USAF	2.50°-3.50°	(All IAPS)
USN	2.50°-3.77°	(All IAPS)

Note 1: Minimum VDA N/A to circling only procedures.

Note 2: CAT D/E VDA above 3.50 degrees must be annotated "Not for Civil Use."

The calculated VDA and the VGSI may be considered equivalent when the calculated angle is ± 0.20 degrees of the VGSI angle and the TCH used for the calculation is ± 3 ft of the VGSI TCH.

For a straight-in aligned procedure, when the minimum angle has not been achieved, modify the fix location or raise the FAF/PFAF altitude.

Calculate VDA based on the distance from the plotted position of the FAF/PFAF or stepdown fix to the plotted position of the final end point (FEP). The FEP is a point on the FAC equal to the distance from the FAF/PFAF to runway threshold (RWT) coordinates (or displaced threshold coordinates when applicable) or from FAF/PFAF to the edge of first usable landing surface for circling only aligned procedures. See figure 14-4.

Figure 14-4. Final End Point [Par 252].

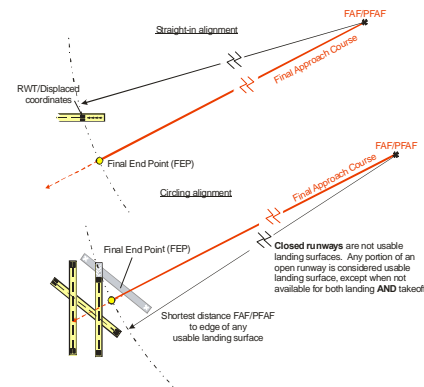

a. **Calculating Descent Angle (procedures meeting straight-in alignment).** Calculate the VDA from the FAF/PFAF altitude (or stepdown fix altitude per Vol. 1, chapter 2, paragraphs 252c(1) or 252d) to threshold crossing height (TCH) using the following formula (radian calculations):

$$\theta_{DESCENT} = a \tan \left(\ln \left(\frac{r + alt}{r + THRe + TCH} \right) \cdot \frac{r}{D_{FIX}} \right) \cdot \frac{180}{\pi}$$

Where:

- atan = arc tangent
- ln = Natural logarithm
- alt = FAF/PFAF alt. or 252c(1) / 252d stepdown alt.
- THRe = Threshold elevation
- r = 20890537
- TCH = VGSI or Design TCH
- D_{FIX} = Dist. (ft) FAF/PFAF or stepdown fix to FEP

EXAMPLE

- alt = 2,600 ft MSL
- THRe = 1,012 ft MSL
- TCH = 46 ft
- D_{FIX} = 29,420.537 ft or 4.84 NM

$\theta_{DESCENT} = 3.00$ degrees (round to nearest 0.01 degrees)

Policy Memo Dec 28 2007

When the maximum VDA calculated in accordance with Vol. 1, chapter 2, paragraph 252a is exceeded and altitudes/fix locations cannot be modified, straight-in minimums are not authorized. The procedure may be approved when restricted to circling minimums **IF** less than or equal to maximum VDA calculated in accordance with Vol. 1, chapter 2, paragraph 252b. In this case, when VDA is published, specify the VDA calculated in accordance with Vol. 1, chapter 2, paragraph 252a (published angle MAY exceed the maximum).

(1) Determining straight-in FAF/PFAF or stepdown fix location to achieve a specified design angle. Use where fix location is flexible; e.g., FAF/PFAF or stepdown fix may be defined by an Area Navigation (RNAV), Distance Measuring Equipment (DME), or intersection fix. Where a VGSI is installed and within the range of minimum/maximum VDAs, select a fix location which permits a VDA equivalent with the VGSI angle. When it is not feasible to achieve equivalency (e.g., VGSI is not within the range of acceptable angles, or VGSI is not installed), select a fix location to achieve an optimum VDA when possible or within standard VDA range. Determine the FAF/PFAF or stepdown fix location (distance from threshold to fix) using the formula in *figure 14-5* (radian calculations).

Figure 14-5. Straight-In FAF/PFAF or Stepdown Fix Distance Based on Altitude and Angle [Par 252a].

$$D_{PFAF} = \frac{\ln\left(\frac{r + \text{alt}}{r + \text{THRe} + \text{TCH}}\right) \cdot r}{\tan\left(\theta \cdot \frac{\pi}{180}\right)}$$

Where:

- In = Natural logarithm
- alt = Minimum FAF/PFAF or stepdown fix altitude
- THRe = Threshold elevation
- TCH = VGSI or Design TCH
- r = 20890537
- θ = VGSI or specified VDA

EXAMPLE

- alt = 2,600 ft MSL
- THRe = 1,012 ft MSL
- TCH = 46.0
- θ = 3.00 degrees
- D_{PFAF} = 29,420.537 ft or 4.84 NM

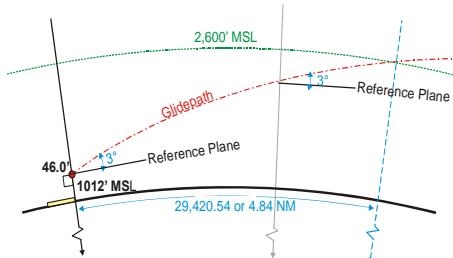

b. Calculating VD As (p rocedures not meeting s traight-in a lignment or s traight-in aligned proc edures not authorized s traight-in minimums). Calculate the VDA from the FAF/PFAF or stepdown fix altitude (Vol. 1, chapter 2, paragraphs 252c(2) or 252d) to the lowest CMDA using the following formula (radian calculations).

$$\theta_{CIRCLEDESCENT} = a \tan\left(\ln\left(\frac{r + \text{alt}}{r + \text{CMDA}}\right) \cdot \frac{r}{D_{FIX}}\right) \cdot \frac{180}{\pi}$$

Where:

- In = Natural logarithm
- r = 20890537
- alt = FAF/PFAF or Vol. 1, chapter 2, para. 252c(2) / 252d stepdown fix altitude
- CMDA = Lowest Published CMDA
- D_{FIX} = Dist. (ft) FAF/PFAF or stepdown fix to FEP

EXAMPLE

- alt = 2,900 ft MSL
- CMDA = 1,320 ft MSL
- D_{FIX} = 29,043.83 ft or 4.78 NM
- θ_{CIRCLEDESCENT} = 3.11354 degrees
- (round to nearest 0.01 degrees)

When the MAXIMUM VDA is exceeded, relocate the PFAF/stepdown fix and/or raise the CMDA until the angle is compliant.

(1) Determining Circling FAF/PFAF location to achieve a s pecified d esign an gle. Procedures designed to circling alignment standards are not normally flown using a stabilized descent from the FAF/PFAF to landing. Therefore, the FAF/PFAF location is not **predicated** on VDA; however, the achieved angle must not exceed the maximum VDA. Establish the FAF/PFAF location in accordance with the alignment and segment length criteria applicable to the final approach Navigational Aid (NAVAID) or system and calculate the circling VDA.

c. Stepdown F ixes (with F AF proc edures and/or proc edures publi shed w/out P A/APV minima). Establish stepdown fixes at the lowest altitude possible that also provides obstacle clearance. When minimum fix altitudes are above the vertical profile of a VDA calculated in accordance with Vol. 1, chapter 2, paragraph 252a or 252b, adjust the stepdown fix location(s) if feasible. Determine the altitude of the vertical path at a stepdown fix using the following formula (radian calculations).

$$Z_{\text{vertical path}} = e^{\frac{D_z \times \tan\left(\theta \times \frac{\pi}{180}\right)}{r}} \times (r + \text{base}_{\text{alt}}) - r$$

Where:

- e = base of natural log. (Napier's constant)
- D_z = dist (ft) from FEP to fix
- θ = angle calculated in accordance with Vol. 1, chapter 2, paragraph 252a/252b
- r = 20890537
- base_{alt} = THRe + TCH (Vol. 1, chapter 2, paragraph 252a)
- base_{alt} = CMDA (Vol. 1, chapter 2, paragraph 252b)

When stepdown fix location(s) cannot be modified, change the FAF/PFAF location or raise the FAF/PFAF altitude until stepdown fix(es) are at or below the vertical path of the VDA (must not exceed the maximum angle).

(1) For straight-in aligned procedures ONLY, when no other option is practical, calculate a VDA from each stepdown fix altitude above the vertical path (apply Vol. 1, chapter 2, paragraph 252a). Publish the greatest VDA and associate it with the applicable stepdown fix. See figure 14-6.

(2) For circling aligned procedures, when no other option is practical, calculate a VDA from each stepdown fix altitude above the vertical path (apply paragraph 252b) and ensure each angle is less than or equal to the maximum angle.

Figure 14-6. VDA with Stepdown Fixes [Par 252c].

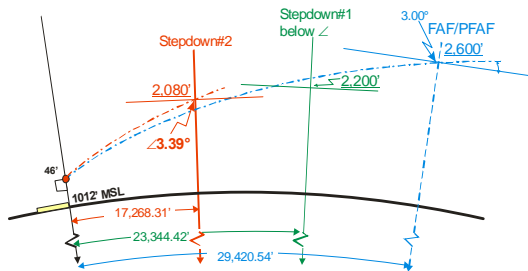

(3) DO NOT raise stepdown fix altitudes higher than needed for obstacle clearance solely to achieve coincidence with the VDA vertical path (USN N/A).

4) DO NOT establish maximum, mandatory, or mandatory block altitudes at any final segment fix except where operationally required and approved by AFS-400 or appropriate military authority. Approval will include a check of the final sub-segment descent rates and will specify necessary restrictions (e.g. do not publish VDA, etc.).

d. Stepdown Fixes (non-FAF procedures). Apply Vol. 1, chapter 2, paragraph 252a or 252b to calculate the VDA from the stepdown fix. When there are multiple stepdown fixes, also apply Vol. 1, chapter 2, paragraph 252c, except the vertical path is calculated from the first stepdown fix (farthest from RWT coordinates) instead of from the FAF/PFAF.

253. VISUAL DESCENT POINT (VDP). The VDP defines a point on an NPA procedure from which normal descent from the MDA may be commenced provided the required visual references have been acquired. **ESTABLISH A VDP FOR ALL STRAIGHT-IN NPA PROCEDURES** (to include those

combined with a PA/APV procedure), with the following exceptions/limitations:

- Do not publish a VDP when the **primary** altimeter setting comes from a remote source.
- Do not publish a VDP located prior to a stepdown fix.
- If the VDP is between the MAP and the runway, do not publish a VDP.
- Do not publish a VDP when the 20:1 surface is penetrated (Vol. 1, chapter 3, paragraph 3.3.2d).
- When feasible, the VDP **should** be ≥ 1 NM from any other final segment fix (e.g., MAP, stepdown). When not feasible, the VDP **must** be at least 0.5 NM from any other final segment fix. If < 0.5 NM and the other fix cannot be relocated, do not publish a VDP. **DO NOT** increase the MDA to achieve the ≥ 0.5 NM distance.

a. Determine VDP distance. When dual or multiple lines of NPA minimums are published, use the lowest minimum descent altitude (MDA) from any CAT to calculate the VDP distance. Use the following formula to determine VDP distance from RWT coordinates (radian calculations):

$$D_{VDP} = r \cdot \left(\frac{\pi}{2} - \theta \cdot \frac{\pi}{180} - a \sin \left(\frac{\cos \left(\theta \cdot \frac{\pi}{180} \right) \cdot (r + \text{THRe} + \text{TCH})}{r + \text{MDA}} \right) \right)$$

Where:

MDA = Lowest Minimum Descent Altitude

THRe = Threshold elevation

TCH = VGSI or Design TCH

$r = 20890537$

$\theta = \text{VGSI or specified VDA}$

(1) For runways served by a VGSI (regardless of coincidence with final VDA), using the VGSI TCH, establish the distance from RWT coordinates to a point where the lowest published VGSI glidepath angle reaches the appropriate MDA.

(2) For runways NOT served by a VGSI, using an appropriate TCH from Vol. 3, chapter 2, table 2-3, establish the distance from RWT coordinates to a point where the greater of a three degree or the final segment VDA reaches the appropriate MDA.

b. Marking VDP Location.

(1) For Non-RN AV Standard Instrument Approach Procedures (SIA Ps), mark the VDP location with a DME fix. The DME source must be the same as for other DME fixes in the final segment. If DME is not available, do not establish a VDP. Maximum fix error is ± 0.5 NM.

(2) For RNAV SIAPs, mark the VDP location with an Along Track Distance (ATD) fix to the MAP. Maximum fix error is ± 0.5 NM.

(3) If the final course is not aligned with the runway centerline, use the RWT coordinates as a vertex, swing an arc of a radius equal to the VDP distance across the final approach course (see figure 14-7). The point of intersection is the VDP. (For RNAV procedures, the distance from the point of intersection to the MAP is the ATD for the VDP.)

Figure 14-7. VDP Location [Par 253b(3)].

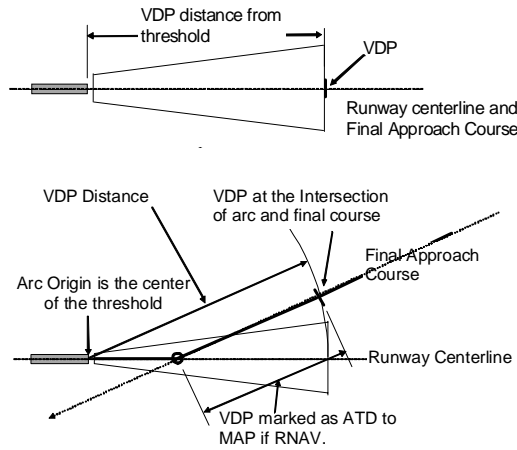

254.-259. RESERVED.

SECTION 6. CIRCLING APPROACH

260. CIRCLING APPROACH AREA. Where circling is authorized, evaluate the circling approach area for each CAT published on the procedure. The Circling Minimum Descent Altitude (CMDA) is based on the results of the circling area evaluation and the evaluation of the final segment delivering the aircraft to the circling area. Also see Vol. 1, chapter 3, paragraph 3.2.1b.

a. Obstacle Evaluation Area (OEA). The area for each CAT is based on true airspeed (V_{KTAS}). The minimum altitude used for true airspeed conversion is 1,000 ft above airport elevation.

Use the following formula for converting indicated airspeed (V_{KIAS}) to true airspeed (V_{KTAS}) is:

$$V_{KTAS} = \frac{V_{KIAS} \cdot 171233 \cdot \sqrt{(288 + 15) - 0.00198 \cdot (\text{alt} + k)}}{(288 - 0.00198 \cdot (\text{alt} + k))^{2.628}}$$

Where:

- V_{KIAS} = indicated airspeed (from table 4)
- alt = airport elevation (MSL)
- k = height above airport (1,000 ft minimum)

Calculate the Circling Approach Radius (CAR) based on true airspeed, bank angle, and straight segment

length using the following formula (radian calculations):

$$*CAR = 2 \cdot \frac{(V_{KTAS} + 25)^2}{\tan(\text{bank}_{\text{angle}} \cdot \frac{\pi}{180}) \cdot 68625.4} + S$$

Where:

- V_{KTAS} = true airspeed
- bank_{angle} = bank angle (from table 4)
- S = straight segment (from table 4)

*Minimum CAR = 1.30 NM

Table 4. Circling Approach Area Parameters [Par 260a].

CAT V	KIAS	Bank _{angle}	Straight Segment Length (S)
A	90	25	0.4
B	120	25	0.4
C	140	20	0.5
D	165	20	0.6
E	200	22	0.7

The OEA is constructed by drawing arcs equal to the CAR for each CAT from the RWT coordinates (or displaced threshold coordinates when applicable) of each runway. Not applicable to permanently closed or other runways not authorized for circling. However, when only one end of the runway is not authorized for circling, the OEA is based on the CAR from both sets of RWT coordinates. Join the outermost arcs with tangential lines. The resulting enclosed area is the circling OEA [no secondary area]. See figure 15-1.

b. Obstacle Clearance. Provide 300 ft ROC plus adjustments over the highest obstacle in the OEA.

Figure 15-1. Circling Approach OEA [Par 260a].

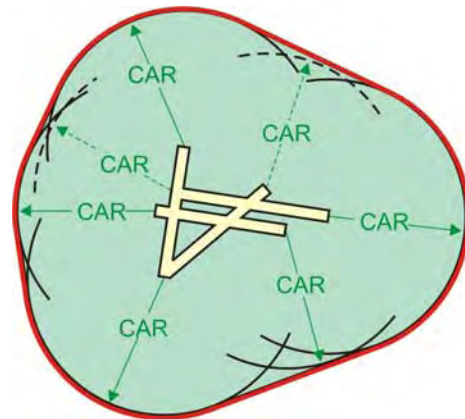

c. CMDA. The published Circling Minimum Descent Altitude (CMDA) may not result in a Height

Above Airport (HAA) lower than permitted by Vol. 1, chapter 3, table 3-9.

Where the CMDA results in a HAA greater than 1,000 ft, re-calculate CAR by increasing *k* to equal the actual HAA and re-evaluate the OEA. If the resulting HAA value increases, re-calculate and re-evaluate using the higher value.

Example
CAT A controlling obstacle = 623 ft
Airport Elevation = 600 ft
CAT A minimum HAA (Vol. 1, chap 3) = 350 ft
ROC = 300
CMDA based on ROC
623 + 300 = 923 (rounds to 940 ft)
CMDA based on min HAA
600 + 350 = 950 ft (rounds to 960 ft)
Published CMDA = 960 ft

261. RESTRICTED CIRCLING AREA. The circling OEA may be modified to gain relief from obstacles by establishing a restricted area. This option is only authorized where the restriction can clearly be described as a portion of the airspace where circling is not authorized and the chart is properly annotated. The OEA excludes the restricted area except the portion defined by a line originating at the RWT coordinates (or displaced threshold coordinates when applicable) of each runway used to define the area splaying 10 degrees relative to runway centerline towards the restricted area. Discontinue the splay when it reaches 4,500 ft in width from runway centerline extended (see figure 15-2a).

a. Simple restricted area. Establish the restricted area as the right or left half of the OEA relative to runway centerline(s) extended to the CAR boundary. The chart annotation must include the runway identification (both ends) and the area's magnetic direction from runway centerline described as a cardinal/inter-cardinal compass direction (N, NE, E, SE, S, SW, W, NW). See Vol. 1, chapter 2, figures 15-2a through 15-2f and Order 8260.19, chapter 8.

Figure 15-2a. Restricted Circling Area (Simple) [Par 261a].

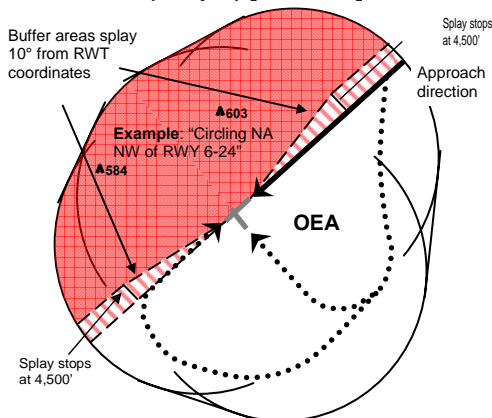

b. Complex restricted area. Establish the restricted area as a single contiguous sector bounded by the centerlines of intersecting runways (or runways extended) continued outward to the OEA boundary, truncated (figures 15-2b through 15-2d) or expanded (figure 15-2f) by a direct line from each set of RWT coordinates (or displaced threshold coordinates when applicable). The chart annotation includes the runway number and the general orientation of the restricted area from each runway described as a cardinal/inter-cardinal compass direction. See Vol. 1, chapter 2, figures 15-2b through 15-2g and Order 8260.19, chapter 8.

Figure 15-2b. Restricted Circling Area (Complex <180°) [Par 261b].

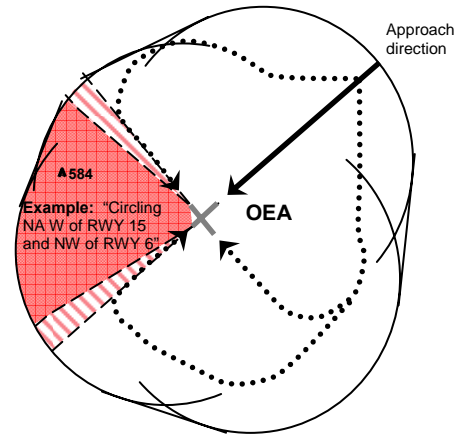

Figure 15-2c. Restricted Circling Area, Circling Aligned (Complex <180°) [Par 261b].

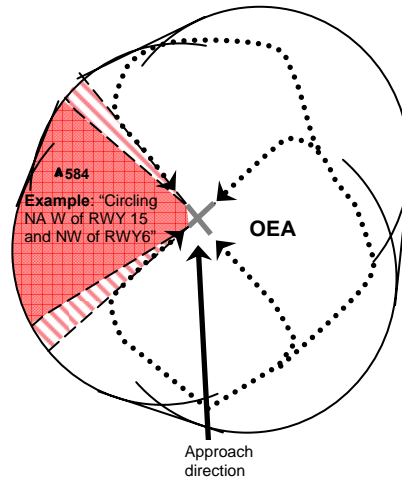

Figure 15-2d. Restricted Circling Area (Complex < 180°, Intersecting runways) [Par 261b].

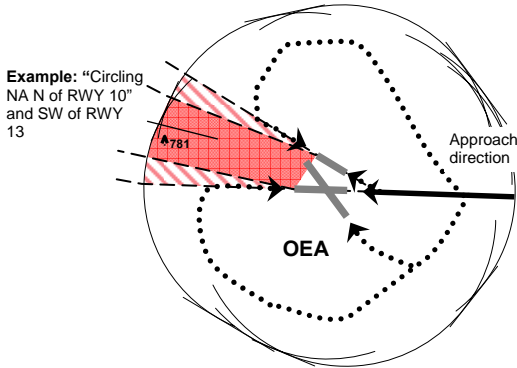

Figure 15-2e. Restricted Circling Area (Complex < 180°, Parallel runways) [Par 261b].

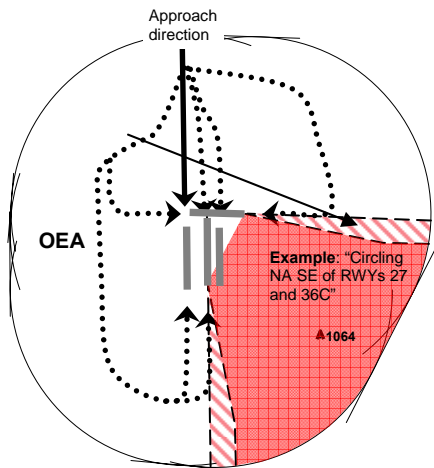
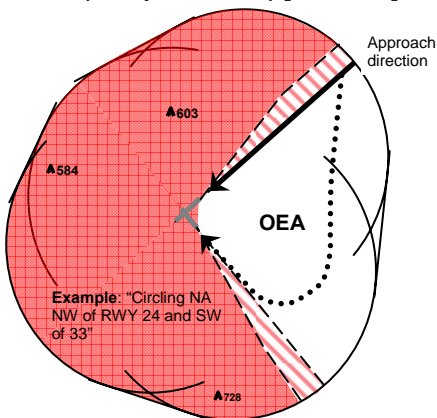

Figure 15-2f. Restricted Circling Area (Complex > 180°) [Par 261b].



262.-269. RESERVED.

SECTION 7. MISSED APPROACH.

270. MISSED APPROACH SEGMENT. A missed approach procedure shall be established for each instrument approach procedure (IAP). The missed approach shall be initiated at the Decision Altitude (DA) or MAP in nonprecision approaches. The missed approach procedure must be simple, specify a charted missed approach altitude (altitude at clearance limit), and a clearance limit fix/facility. When required by obstacles or deemed operationally advantageous, the missed approach may also specify an interim "climb-to" altitude to identify a turn point. The charted missed approach altitude must not be lower than the highest DA/MDA (including adjustments) and be sufficient to permit holding or en route flight. Design alternate missed approach procedures using the criteria in this section. The area considered for obstacles has a width equal to that of the final approach area at the MAP or DA point and expands uniformly to the width of the initial approach

(Continued on Page 27)

THIS PAGE INTENTIONALLY LEFT BLANK

segment at a point 15 flying miles from the MAP. When PCG is available, a secondary area for the reduction of obstacle clearance is identified within the missed approach area. It has the same width as the final approach secondary area at the MAP, and expands uniformly to a width of 2 miles at a point 15 miles from the MAP (see figure 16). Where PCG is not available beyond this point, expansion of the area continues until PCG is achieved or segment terminates. Where PCG is available beyond this point, the area tapers at a rate of 30° inward relative to the course until it reaches initial segment width.

NOTE: Only the primary missed approach procedure shall be included on the published chart.

271. MISSED APPROACH ALIGNMENT.

Wherever practical, the missed approach course should be a continuation of the FAC. Turns are permitted, but should be minimized in the interest of safety and simplicity.

272. MAP. The MAP specified in the procedure may be the point of intersection of an electronic glidepath with a DH, a navigation facility, a fix, or a specified distance from the FAF. The specified distance may not be more than the distance from the FAF to the usable landing surface. The MAP shall **NOT** be located prior to the VDP. Specified criteria for the MAP are contained in the appropriate facility chapters.

273. STRAIGHT MISSED APPROACH AREA.

When the missed approach course is within 15° of the final approach course, it is considered a straight missed approach (see figure 16). The area considered for obstacle evaluation is specified in paragraph 270.

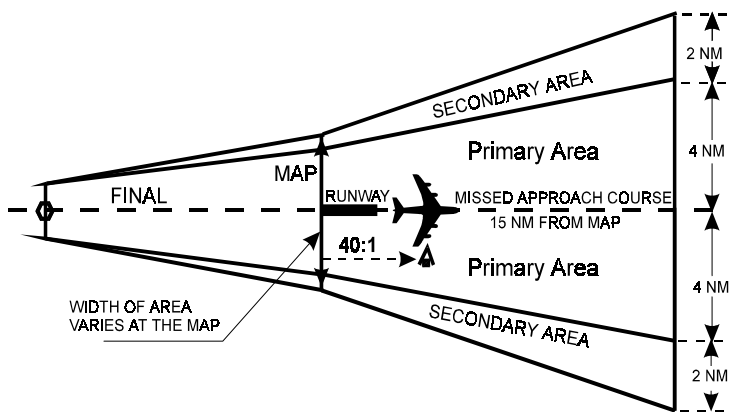

Figure 16. STRAIGHT MISSED APPROACH AREA. Par 270 and 273.

274. STRAIGHT MISSED APPROACH OBSTACLE CLEARANCE.

Within the primary missed approach area, no obstacle shall penetrate the missed approach surface. This surface begins over the MAP at a height determined by subtracting the required final approach ROC and any minima adjustments, per paragraph 323 from the MDA. It rises uniformly at a rate of 1 foot vertically for each 40 feet horizontally (40:1). See figure 17. Where the 40:1 surface reaches a height of 1,000 feet below the missed approach altitude (paragraph 270), further application of the surface is not required. In the secondary area, no obstacle may penetrate a 12:1 slope that extends outward and upward from the 40:1 surface at the inner boundaries of the secondary area. See figure 18. Evaluate the missed approach segment to ensure obstacle clearance is provided.

Policy Memo Dec 28 2007 Policy Memo Nov 16 2010

a. Evaluate the 40:1 surface from the MAP to the clearance limit (end of the missed approach segment). The height of the missed approach surface over an obstacle is determined by measuring the straight-line distance from the obstacle to the nearest point on the line defining the origin of the 40:1 surface. If obstacles penetrate the surface, take action to eliminate the penetration.

b. The preliminary charted missed approach altitude is the highest of the minimum missed approach obstruction altitude, minimum holding altitude (MHA) established IAW paragraph 293a, or the lowest airway minimum en route altitude (MEA) at the clearance limit. To determine the minimum missed approach obstruction altitude for the missed approach segment, identify the highest obstacle in the primary area; or if applicable, the highest equivalent obstacle in the secondary area. Then add the appropriate ROC (plus adjustments) for holding or en route to the highest obstacle elevation. Round the total value to the nearest hundred-foot value.

c. Determine if a climbing in holding pattern (climb-in-hold) evaluation is required (see paragraph 293b). If a climb in holding is intended at the clearance limit, a climb-in-hold evaluation is mandatory.

(1) Calculate the elevation of the 40:1 surface at the end of the segment (clearance limit). The 40:1 surface starts at the same elevation as it does for obstacle evaluations. Compute the 40:1 rise from a point on the line defining the origin of the 40:1 surface in the shortest distance and perpendicular to the end-of-segment line at the clearance limit.

(2) Compute the ROC surface elevation at the clearance limit by subtracting the appropriate ROC (plus adjustments) from the preliminary charted missed approach altitude.

(3) **Compare the ROC surface elevation** at the clearance limit with the 40:1 surface elevation.

(a) If the computed 40:1 surface elevation is equal to or greater than the ROC surface elevation, a climb-in-hold evaluation is NOT required.

(b) If the computed 40:1 surface elevation is less than the ROC surface elevation, a climb-in-hold evaluation **IS** required. FAA Order 7130.3, Holding Pattern Criteria, paragraph 35, specifies higher speed groups and, therefore, larger template sizes are usually necessary for the climb-in-hold evaluation. These templates may require an increase in MHA under TERPS, paragraph 293a. If this evaluation requires an increase in the MHA, evaluate the new altitude using the higher speed group specified in paragraph 35. This sequence of review shall be used until the MHA does not increase, then the 40:1 surface is re-evaluated. If

obstacles penetrate the 40:1 surface, take action to eliminate the penetration.

d. **The charted missed approach altitude** is the higher of the preliminary charted missed approach altitude or the MHA established under paragraph 274c(3)(b).

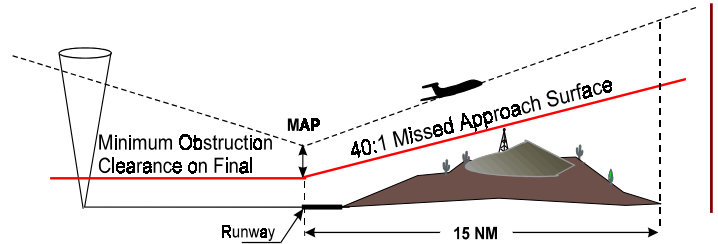

Figure 17. STRAIGHT MISSED APPROACH OBSTACLE CLEARANCE. Par 274.

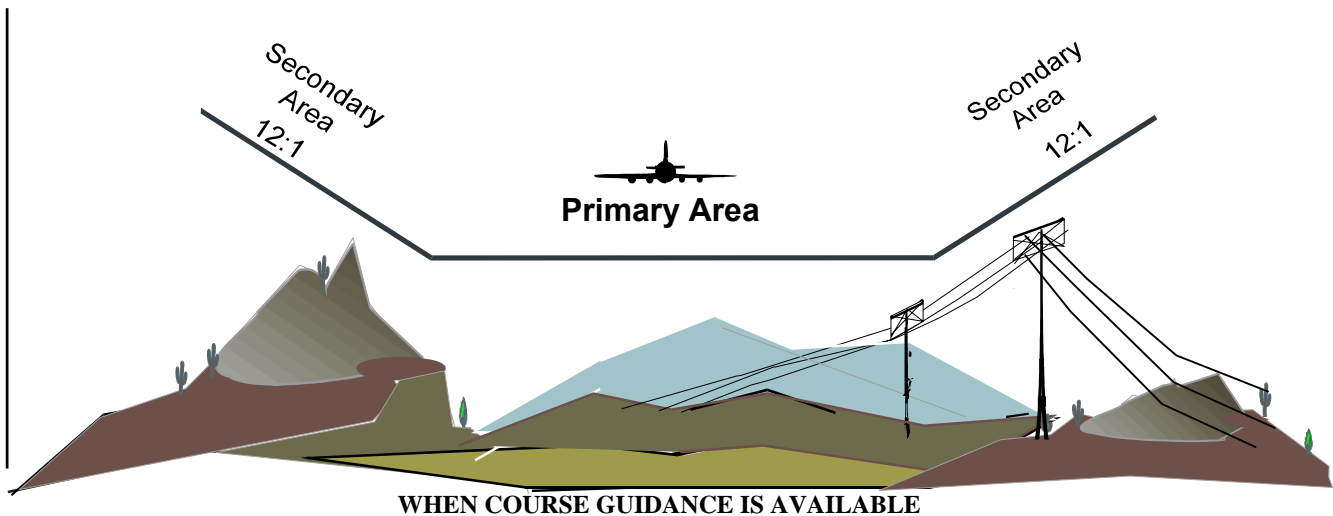

Figure 18. MISSED APPROACH CROSS SECTION. Par 274.

275. TURNING MISSED APPROACH AREA. (See Volume 3 for special provisions). If a turn of more than 15° from the FAC is required, a turning or combination straight and turning missed approach area must be constructed.

NOTE: If the HAT value associated with the DA/MDA is less than 400 feet, construct a combination straight and turning missed approach (see paragraph 277) to accommodate climb to 400 feet above touchdown zone elevation prior to turn.

a. **The dimensions and shape** of this area are affected by three variables:

- (1) **Width of final approach area** at the MAP.
- (2) **All categories of aircraft** authorized to use the procedure.
- (3) **Number of degrees of turn** required by the procedure.

b. Secondary areas for the reduction of obstacle clearance are permitted when PCG is provided. The secondary area begins where a line perpendicular to the straight flightpath, originating at the point of completion of the turn, intersects the outer boundaries of the missed approach segment. The width of the secondary area expands uniformly from zero to 2 miles at 15 NM flight track point.

c. Primary areas. Figures 19, 20, 21, 22, 23, and 24 show the manner of construction of some typical turning missed approach areas. The following radii are used in the construction of these areas:

(1) 90° Turn or Less. Narrow Final Approach Area at MAP. See figure 19. To construct the area:

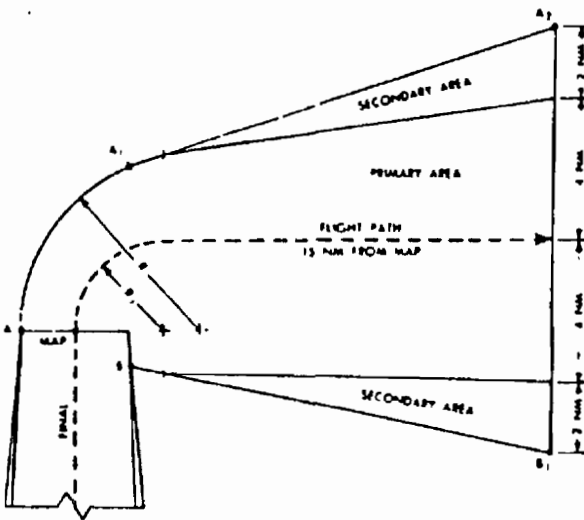

Figure 19. TURNING MISSED APPROACH AREA. 90° Turn or Less. Narrow Final Approach Area at MAP. Par 275c(1).

(a) Draw an arc with the radius (R_1) from the MAP. This line is then extended outward to a point 15 miles from the MAP, measured along the line. This is the assumed flightpath (see table 5).

Table 5. TURNING MISSED APPROACH RADII (Miles). Par 275.

Approach Category	Obstacle Clearance Radius (R)	Flightpath Radius (R_1)
A	2.6	1.30
B	2.8	1.40
C	3.0	1.50
D	3.5	1.75
E	5.0	2.50

(b) Establish points "A₂" and "B₁" measuring 6 miles perpendicular to the flightpath at the 15 mile point.

(c) Now connect "A₂" and "B₁" with a straight line.

(d) Draw an arc with the radius (R) from point "A" to "A₁". This is the edge of the obstacle clearance area.

(e) Establish point "B" by measuring backward on the edge of the final approach area a distance of 1 mile or a distance equal to the fix error PRIOR to the FAF, whichever is greater.

(f) Connect points "A₁" and "A₂", and points "B" and "B₁" with straight lines.

(2) 90° Turn or Less. Wide Final Approach Area at MAP. See figure 20. To construct the area:

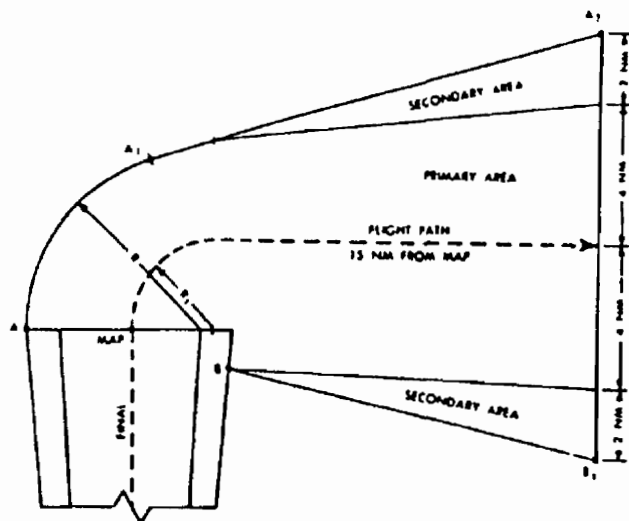

Figure 20. TURNING MISSED APPROACH AREA. 90° Turn or Less. Wide Final Approach Area at MAP. Par 275c(2)

(a) Draw an arc with the appropriate radius (R_1) from the MAP. This line is then extended outward to a point 15 miles from the MAP, measured along the line. This is the assumed flightpath.

(b) Establish points "A₂" and "B₁" by measuring 6 miles perpendicular to the flightpath at the 15-mile point.

(c) Now connect "A₂" and "B₁" with a straight line.

(d) Draw an arc with the appropriate radius (R) from point "A" to point "A₁". This is the edge of the obstacle clearance area.

(e) Establish point "B" by measuring backward on the edge of the final approach area a distance of 1 mile or a distance equal to the fix error PRIOR to the FAF, whichever is greater.

(f) Connect points "A₁" and "A₂", and points "B" and "B₁" with straight lines.

(3) **More Than 90° Turn. Narrow Final Approach Area at MAP** (see figure 21). To construct the area:

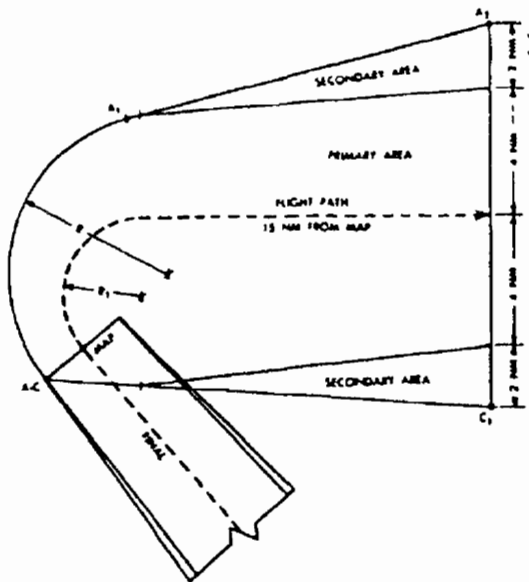

Figure 21. TURNING MISSED APPROACH AREA. More Than 90° Turn. Narrow Final Approach Area at MAP. Par 275c(3).

(a) Draw an arc with the radius (R_1) from the MAP through the required number of degrees and

then continue outward to a point 15 miles from the MAP, measured along this line, which is the assumed flightpath.

(b) Establish points "A₂" and "C₁" by measuring 6 miles on each side of the assumed flightpath and perpendicular to it at the 15-mile point.

(c) Now connect points "A₂" and "C₁" with a straight line.

(d) Draw an arc with the radius (R) from point "A" to point "A₁" (figure 21 uses 135°). This is the outer edge of the obstacle clearance area.

(e) Locate point "C" at the inner edge of the final approach secondary area opposite the MAP. (Point "A" and point "C" will be coincident when the MAP is the facility.)

(f) Connect points "A₁" and "A₂", and points "C" and "C₁" with straight lines.

(4) **More than 90° Turn. Wide Final Approach Area at MAP** (see figure 22). To construct the area:

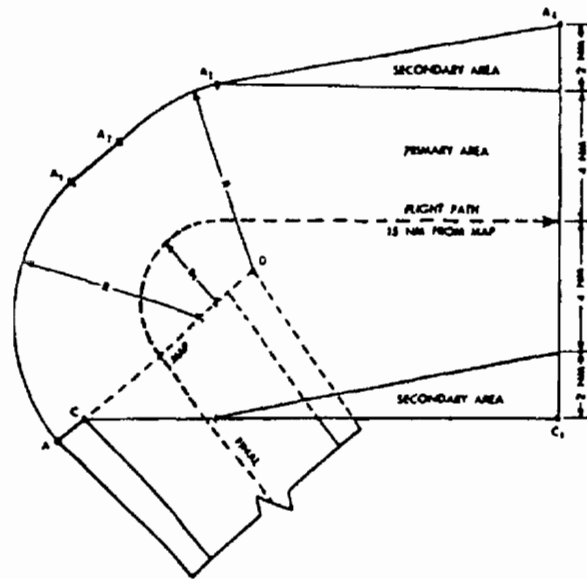

Figure 22. TURNING MISSED APPROACH AREA. More Than 90° Turn. Wide Final Approach Area at MAP. Par 275c(4).

(a) Draw the assumed flightpath arc with the radius (R_1) from the MAP the required number of degrees to the desired flightpath or course.

(b) Establish points "A₄" and "C₁" by measuring 6 miles on each side of the assumed flightpath and perpendicular to it at the 15-mile point.

(c) Connect points "A₄" and "C₁" with straight lines.

(d) Draw a 90° arc with the appropriate radius (R) from point "A" to "A₁". Note that when the width of the final approach area at the MAP is greater than the appropriate radius (R), the turn is made in two increments when constructing the obstacle clearance area.

(e) Draw an arc with the radius (R) from point "D" (edge of final approach secondary area opposite MAP) the required number of degrees from point "A₂" to point "A₃". Compute the number of degrees by subtracting 90° from the total turn magnitude.

(f) Connect points "A₁" and "A₂", with a straight line.

(g) Locate point "C" at the inner edge of the final approach secondary area opposite the MAP.

(h) Connect point "A₃" with point "A₄", and connect point "C" with point "C₁" using straight lines.

(5) 180° Turn. Narrow Final Approach Area at MAP (see figure 23). To construct the area:

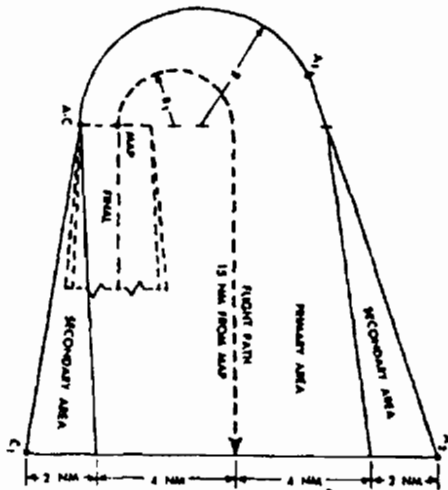

Figure 23. TURNING MISSED APPROACH AREA. 180° Turn. Narrow Final Approach Area at MAP. Par 275c(5).

(a) Draw an arc with the radius (R₁) from the MAP through 180°, and then continue outward to a

point 15 miles from the MAP, measured along this line, which is the assumed flightpath.

(b) Establish points "A₂" and "C₂" by measuring 6 miles on each side of the assumed flightpath, and perpendicular to it at the 15-mile point.

(c) Now connect points "A₂" and "C₂" with a straight line.

(d) Locate point "C" at the inner edge of the final approach secondary area opposite the MAP. (Point "A" and point "C" will be coincident when the MAP is the facility.)

(e) Draw an arc with the radius (R) from point "A" to point "A₁" (180°). This is the outer edge of the obstacle clearance area.

(f) Connect points "A₁" and "A₂", and points "C" and "C₁" by straight lines. (The line "A₁-A₂" joins the arc tangentially).

(6) 180° Turn. Wide Final Approach Area at MAP (see figure 24). To construct the area:

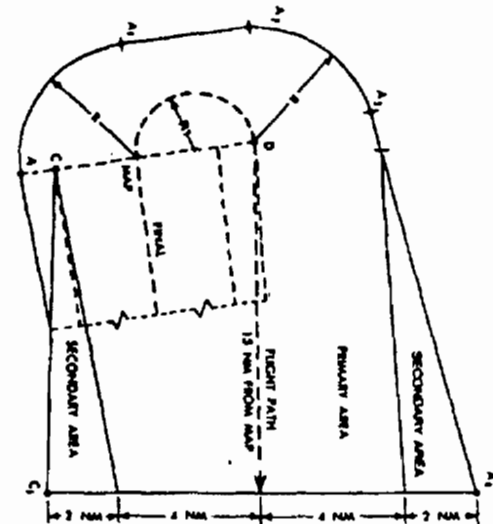

Figure 24. TURNING MISSED APPROACH AREA. 180° Turn. Wide Final Approach Area at MAP. Par 275c(6).

(a) Draw the flightpath arc with radius (R₁) from the MAP and then continue the line outward to a point 15 miles from the MAP, measured along the assumed flightpath.

(b) Establish points "A₄" and "C₁" by measuring 6 miles on each side of the flightpath and perpendicular to it at the 15-mile point.

THIS PAGE INTENTIONALLY LEFT BLANK

(c) Now connect "A₄" and "C₁" with a straight line.

(d) Draw a 90° arc with the appropriate radius (R) from point "A" to "A₁". Note that when the width of the final approach area at the MAP is greater than the appropriate radius (R), the turn is made in two increments when constructing the obstacle clearance area.

(e) Draw an arc with the radius (R) from point "D" (edge of final approach secondary area opposite MAP) the required number of degrees from point "A₂" to point "A₃". Compute the number of degrees by subtracting 90° from the total turn magnitude.

(f) Connect points "A₁" and "A₂", with a straight line.

(g) Locate point "C" at the inner edge of the final approach secondary area opposite the MAP.

(h) Connect points "A₃" and "A₄", and points "C" and "C₁" with straight lines. (The line "A₃-A₄" joins the arc tangentially).

276. TURNING MISSED APPROACH OBSTACLE CLEARANCE. The methods of determining the height of the 40:1 missed approach surface over obstacles in the turning missed approach area vary with the amount of turn involved. Evaluate the missed approach segment to ensure the 40:1 OIS is not penetrated.

a. 90° Turn or Less. See figure 25. Zone 1 is a 1.6 mile continuation of the final approach secondary area, and has identical obstacle clearance requirements. Zone 2 is the area in which the height of the missed approach surface over an obstacle must be determined. To do this, first identify line "A-D-B". Point "B" is located by measuring backward on the edge of the final approach area a distance of 1 mile or a distance equal to the fix error prior to the FAF, whichever is greater. This is to safeguard the short-turning aircraft. Thus, the height of the missed approach surface over an obstacle in zone 2 is determined by measuring the straight-line distance from the obstacle to the nearest point on line "A-D-B"

and computing the height based on the 40:1 ratio. The height of the missed approach surface over the MAP is the same as specified in paragraph 274. When an obstacle is in a secondary area, measure the straight-line distance from the nearest point on the line "A-D-B" to the point on the inner edge of the secondary area which is nearest the obstacle. Compute the height of the missed approach surface at this point, using the 40:1 ratio. Then apply the 12:1 secondary area ratio from the height of the surface for the remaining distance to the obstacle.

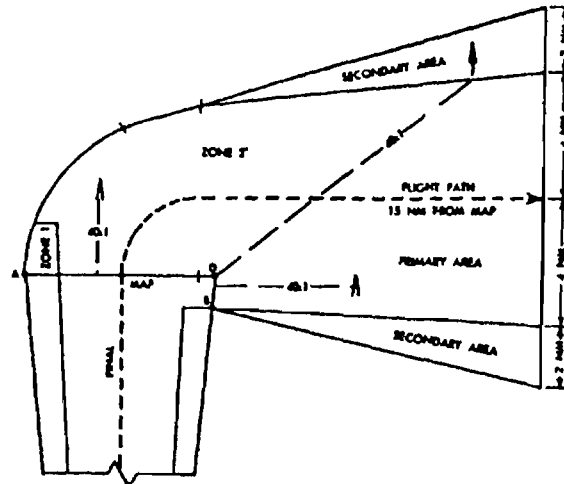

Figure 25. TURNING MISSED APPROACH OBSTACLE CLEARANCE. 90° Turn or Less. Par 276a.

b. More Than 90° Turn. See figure 26. In this case a third zone becomes necessary. Zone 3 is defined by extending a line from point "B" to the extremity of the missed approach area perpendicular to the FAC. Zone 3 will encompass all of the missed approach area not specifically within zones 1 and 2. All distance measurements in zone 3 are made from point "B". Thus the height of the missed approach surface over an obstacle in zone 3 is determined by measuring the distance from the obstacle to point "B" and computing the height based on the 40:1 ratio. The height of the missed approach surface over point "B" for zone 3 computations is the same as the height of the MDA. For an obstacle in the secondary area, use the same measuring method prescribed in paragraph 276a, except that the original measuring point shall be point "B."

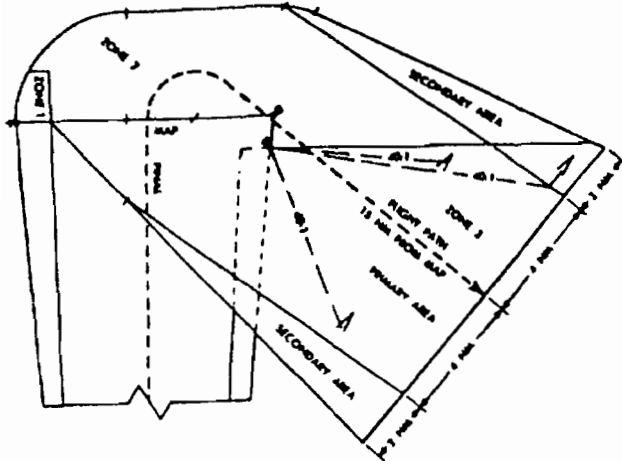

Figure 26. TURNING MISSED APPROACH OBSTACLE CLEARANCE. More Than a 90° Turn. Par 276b.

c. Secondary Area. In the secondary area no obstacles may penetrate a 12:1 slope which extends outward and upward from the 40:1 surface from the inner to the outer boundary lines of the secondary area.

d. Evaluate the missed approach segment from the MAP to the clearance limit. Terminate the 40:1 obstacle clearance surface (OCS) at an elevation corresponding to the en route ROC below the missed altitude.

(1) If the 40:1 OCS terminates prior to the clearance limit, continue the evaluation using a level OIS at the height that the 40:1 OCS was terminated.

(2) If the clearance limit is reached before the 40:1 OCS terminates, continue a climb-in-hold evaluation at the clearance limit.

e. The preliminary charted missed approach altitude is the highest of the minimum missed approach obstruction altitude, MHA established IAW paragraph 293a, or the lowest airway MEA at the clearance limit. To determine the minimum missed approach obstruction altitude for the missed approach segment, identify the highest obstacle in the primary area; or if applicable, the highest equivalent obstacle in the secondary area. Then add the appropriate ROC (plus adjustments) for holding or en route to the highest obstacle elevation. Round the total value to the nearest hundred foot value.

f. Determine if a climb-in-hold evaluation is required (see paragraph 293b).

(1) Calculate the elevation of the 40:1 surface at the end of the segment (clearance limit). The 40:1

surface starts at the same elevation as it does for obstacle evaluations. Compute the 40:1 rise from a point on the "A-D-B" line in the shortest distance to the end-of-segment line at the clearance limit.

(2) Compute the ROC surface elevation at the clearance limit by subtracting the appropriate ROC (plus adjustments) from the preliminary charted missed approach altitude.

(3) Compare the ROC surface elevation at the clearance limit with the 40:1 surface elevation.

(a) If the computed 40:1 surface elevation is equal to or greater than the ROC surface elevation, a climb-in-hold evaluation is NOT required.

(b) If the computed 40:1 surface elevation is less than the ROC surface elevation, a climb-in-hold evaluation IS required. FAA Order 7130.3, Holding Pattern Criteria, paragraph 35, specifies higher speed groups, and, therefore, larger template sizes are usually necessary for the climb-in-hold evaluation. These templates may require an increase in MHA under TERPS paragraph 293a. If this evaluation requires an increase in the MHA, evaluate the new altitude using the higher speed group specified in paragraph 35. This sequence of review shall be used until the MHA does not increase, then the 40:1 surface is re-evaluated. If obstacles penetrate the 40:1 surface, take action to eliminate the penetration.

g. The charted missed approach altitude is the higher of the preliminary charted missed approach altitude or the MHA established under paragraph 274c(3)(b).

277. COMBINATION STRAIGHT AND TURNING MISSED APPROACH AREA. If a straight climb to a specific altitude followed by a turn is necessary to avoid obstacles, a combination straight and turning missed approach area must be constructed. The straight portion of this missed approach area is section 1. The portion in which the turn is made is section 2. Evaluate the missed approach segment to ensure obstacle clearance is provided.

a. Straight Portion. Section 1 is a portion of the normal straight missed approach area and is constructed as specified in paragraph 273. Obstacle clearance is provided as specified in paragraph 274 except that secondary area reductions do not apply. The length of section 1 is determined as shown in figure 27 and relates to the need to climb to a specified altitude prior to commencing the turn. Point A₁ marks the end of

section 1 Point B₁ is one mile from the end of section 1 (see figure 27).

b. Turning Portion. Section 2 is constructed as specified in paragraph 275 except that it begins at the end of section 1 instead of at the MAP. To determine the height which must be attained before commencing the missed approach turn, first identify the controlling obstacle on the side of section 1 to which the turn is to be made. Then measure the distance from this obstacle to the nearest edge of the section 1 area. Using this distance as illustrated in figure 27, determine the height of the 40:1 slope at the edge of section 1. This height, plus the appropriate final ROC, (the sum rounded up to the next higher 100-foot increment) is the height at which the turn should be started. Obstacle clearance requirements in section 2 are the same as those specified in paragraph 276 except that zone 1 is not considered and section 2 is expanded to start at point "B" if no fix

exists at the end of section 1, or if no course guidance is provided in section 2 (see figure 27).

c. Evaluate the 40:1 surface from the MAP to the clearance limit (end of the missed approach segment). If obstacles penetrate the surface, take action to eliminate the penetration.

d. The preliminary charted missed approach altitude is the lowest of the minimum missed approach obstruction altitude, MHA established in accordance with paragraph 293a, or the lowest airway MEA at the clearance limit. To determine the minimum missed approach obstruction altitude for the missed approach segment, identify the highest obstacle in the primary area; or if applicable, the highest equivalent obstacle in the secondary area. Then add the appropriate ROC (plus adjustments) for holding or en route to the highest obstacle elevation. Round the total value to the nearest hundred foot value.

EXAMPLE

Given:

1. MDA 360' MSL
2. Obstacle height: 1098' MSL
3. Obstacle in section 2 = 3NM from near edge of section

Find:

1. Minimum altitude at which aircraft can start turn.
2. Required length of section 1.

Solution:

1. Find height MSL at near edge.
 - a. $A = 18,228' (3 \text{ mi}) \div 40 = 456'$
 - b. $1098' \text{ MSL} - 456' = 642' \text{ MSL}$
2. Add 250' obstacle clearance.
 - a. $250' + 642' = 892' \text{ MSL}$
3. Round up to next higher 20'.
 - a. $892' = 900' \text{ MSL}$ to start turn.
4. Find height to climb from MDA to 900' MSL.
 - a. $900' - 360' = 540'$ to climb.
5. Find length of section 1.
 - a. $540' \times 40 = 21,600'$ -- length of section 1.
6. Missed approach instructions.
 - a. "Climb to 900' before starting right turn to, etc."

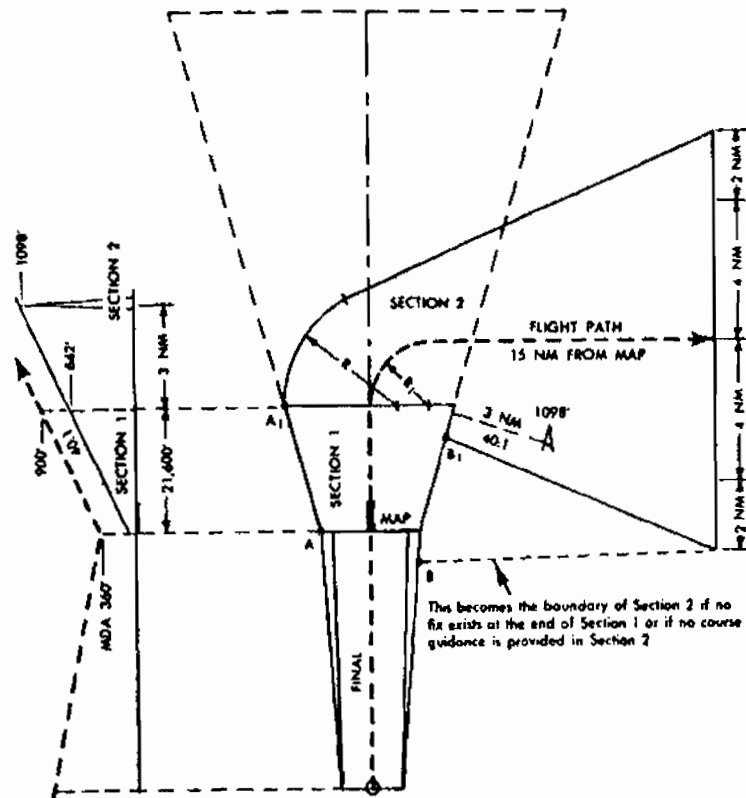

Figure 27. COMBINATION MISSED APPROACH AREA. Par 277(a).

e. Determine if a climb-in-hold evaluation is required (see paragraph 293b).

(1) Calculate the elevation of the 40:1 surface at the end of the segment (clearance limit). The 40:1 surface starts at the same elevation as it does for obstacle evaluations. First, compute the 40:1 rise from a point on the line defining the origin of the 40:1 surface at the MAP, in the shortest distance and perpendicular to the end-of-section 1 segment. If there is a remote altimeter setting source (RASS) and the missed approach instructions do not include a parenthetical climb to altitude then the elevation at the end of section 1 is adjusted by subtracting the altitude difference between the RASS adjustments when two remote altimeter sources are used; or subtracting the RASS adjustment for a part-time altimeter source. The resulting altitude at the end of section 1 shall not be lower than the 40:1 surface height at the MAP. Second, compute the 40:1 rise from a point on the nearest edge of section 1, in the shortest distance to the end-of-segment line at the clearance limit. Add the two values together and this is the 40:1 surface height at the end of the segment (clearance limit).

(2) Compute the ROC surface elevation at the clearance limit by subtracting the appropriate ROC (plus adjustments) from the preliminary charted missed approach altitude.

(3) Compare the ROC surface elevation at the clearance limit with the 40:1 surface elevation.

(a) If the computed 40:1 surface elevation is equal to or greater than the ROC surface elevation, a climb-in-hold evaluation is NOT required.

(b) If the computed 40:1 surface elevation is less than the ROC surface elevation, a climb-in-hold evaluation IS required. FAA Order 7130.3, paragraph 35, specifies higher speed groups and therefore, larger template sizes are usually necessary for the climb-in-hold evaluation. These templates may require an increase in MHA under TERPS paragraph 293a. If this evaluation requires an increase in the MHA, evaluate the new altitude using the higher speed group specified in paragraph 35. This sequence of review shall be used until the MHA does not increase, then the 40:1 surface is re-evaluated. If obstacles penetrate the 40:1 surface, take action to eliminate the penetration.

f. The charted missed approach altitude is the higher of the preliminary charted missed approach

altitude or the MHA established under paragraph 274c(3)(b).

278. END OF MISSED APPROACH. Aircraft shall be assumed to be in the initial approach or en route environment upon reaching minimum obstacle clearance altitude (MOCA) or MEA. Thereafter, the initial approach or the en route clearance criteria apply.

279. RESERVED.

SECTION 8. TERMINAL AREA FIXES

280. GENERAL. Terminal area fixes include, but are not limited to the FAF, the IF, the IAF, the holding fix, and when possible, a fix to mark the MAP. Each fix is a geographical position on a defined course. Terminal area fixes should be based on similar navigation systems. For example, TACAN, omni-directional radio range tactical air navigation (VORTAC), and VOR/DME facilities provide radial/DME fixes. NDB facilities provide bearings. VOR facilities provide VOR radial. The use of integrated (VHF/NDB) fixes shall be limited to those intersection fixes where no satisfactory alternative exists.

281. FIXES FORMED BY INTERSECTION. A geographical position can be determined by the intersection of courses or radials from two stations. One station provides the course the aircraft is flying and the other provides a crossing indication which identifies a point along the course which is being flown. Because all stations have accuracy limitations, the geographical point which is identified is not precise, but may be anywhere within a quadrangle which surrounds the plotted point of intersection. Figure 28 illustrates the intersection of an arc and a radial from the same DME facility and the intersection of two radials or courses from different navigation facilities. The area encompassed by the sides of the quadrangle formed in these ways is referred to in this publication as the "fix displacement area".

282. COURSE/DISTANCE FIXES.

a. A DME fix is formed by a DME reading on a positive navigational course. The information should be derived from a single facility with collocated azimuth and DME antennas. Collocation parameters are defined in FAA Order 6050.32, Spectrum Management Regulations and Procedures. However, when a unique operational requirement indicates a need for DME information from other than collocated facilities, an individual IAP which specifies DME may be approved,

provided the angular divergence between the signal sources at the fix does not exceed 23° (see figure 28). For limitation on use of DME with ILS, see Volume 3, paragraph 2.9.1.

b. ATD Fixes. An ATD fix is an along track position defined as a distance in NM, with reference to the next WP along a specified course.

c. Fixes Formed by Marker Beacons. Marker beacons are installed to support certain NAVAID's that provide course guidance. A marker beacon is suitable to establish a fix only when it marks an along course distance from the NAVAID it is associated with; e.g. localizer and outer markers.

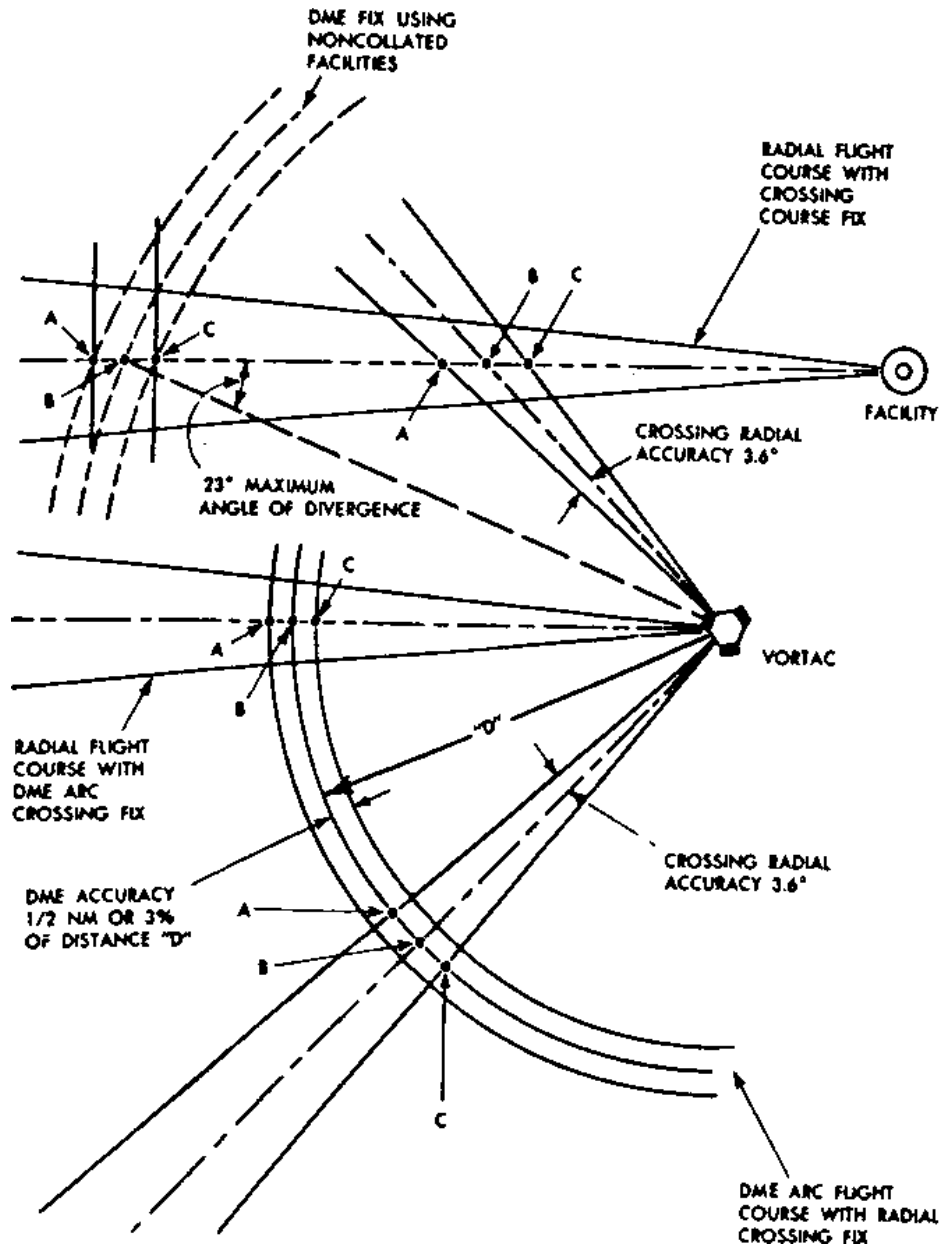

Figure 28. INTERSECTION FIX DISPLACEMENT. Par 281 and 282a.

283. FIXES FORMED BY RADAR. Where ATC can provide the service, Airport Surveillance Radar (ASR) may be used for any terminal area fix. PAR may be used to form any fix within the radar coverage of the PAR system. Air Route Surveillance Radar (ARSR) may be used for initial approach and intermediate approach fixes.

284. FIX DISPLACEMENT AREA. The areas portrayed in figure 28 extend along the flight course from point "A" to point "C". The fix error is a plus-or-minus value, and is represented by the lengths from "A" to "B" and "B" to "C". Each of these lengths is applied differently. The fix error may cause the fix to be received early (between "A" and "B"). Because the fix may be received early, protection against obstacles must be provided from a line perpendicular to the flight course at point "A".

285. INTERSECTION FIX DISPLACEMENT FACTORS. The intersection fix displacement are determined by the system use accuracy of the navigation fixing systems (see figure 29). The system use accuracy in VOR and TACAN type systems is determined by the combination of ground station error, airborne receiving system error, and flight technical error (FTE). En route VOR data have shown that the VOR system accuracy along radial 4.5°, 95 percent of occasions, is a realistic, conservative figure. Thus, in normal use of VOR or TACAN intersections, fix displacement factors may conservatively be assessed as follows:

a. Along-Course Accuracy.

- (1) **VOR/TACAN radials**, plus-or-minus 4.5°.
- (2) **Localizer course**, plus-or-minus 1°.
- (3) **NDB courses or bearing**, plus-or-minus 5°.

NOTE: The plus-or-minus 4.5° (95 percent) VOR/TACAN figure is achieved when the ground station course signal error, the FTE, and the VOR airborne equipment error are controlled to certain normal tolerances. Where it can be shown that any of the three error elements is consistently different from these assumptions (for example, if flight inspection shows a consistently better VOR signal accuracy or stability than the one assumed, or if it can be shown that airborne equipment error is consistently smaller than assumed), VOR fix displacement factors smaller than those shown above may be utilized under paragraph 141.

b. Crossing Course Accuracy.

- (1) **VOR/TACAN radials**, plus-or-minus 3.6°.
- (2) **Localizer course**, plus-or-minus 0.5°.
- (3) **NDB bearings**, plus-or-minus 5°.

NOTE: The plus-or-minus 3.6° (95 percent) VOR/TACAN figure is achieved when the ground station course signal error and the VOR airborne equipment error are controlled to certain normal tolerances. Since the crossing course is not flown, FTE is not a contributing element. Where it can be shown that either of the error elements is consistently different, VOR displacement factors smaller than those shown above may be utilized IAW paragraph 141.

286. OTHER FIX DISPLACEMENT FACTORS.

a. Radar. Plus-or-minus 500 feet or 3 percent of the distance to the antenna, whichever is greater.

b. DME. Plus-or-minus 1/2 (0.5) miles or 3 percent of the distance to the antenna, whichever is greater.

c. 75 MHz Marker Beacon.

- (1) **Normal powered fan marker**, plus-or-minus 2 miles.
- (2) **Bone-shaped fan marker**, plus-or-minus 1 mile.
- (3) **Low powered fan marker**, plus-or-minus 1/2 mile.
- (4) **"Z" marker**, plus-or-minus 1/2 mile.

NOTE: Where these 75 MHz marker values are restrictive, the actual coverage of the fan marker (2 milliamp signal level) at the specific location and altitude may be used instead.

d. Overheading a Station. The fix error involved in station passage is not considered significant in terminal applications. The fix is therefore considered to be at the plotted position of the navigation facility. The use of TACAN station passage as a fix is **NOT** acceptable for holding fixes or high altitude IAF's.

287. SATISFACTORY FIXES.

a. Intermediate, Initial, or Feeder Fix. To be satisfactory as an intermediate, initial, or feeder approach fix, the fix error must not be larger than 50 percent of the appropriate segment distance that follows the fix. Measurements are made from the plotted fix position (see figure 29).

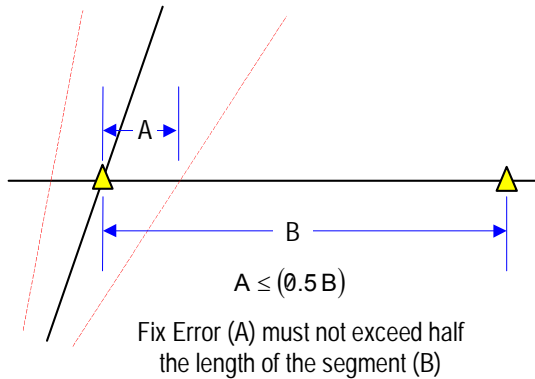

Figure 29. INTERMEDIATE, INITIAL, OR FEEDER APPROACH FIX ERRORS. Par 287.

b. Holding Fixes. Any terminal area fix except overhanging a TACAN may be used for holding. The following conditions shall exist when the fix is an intersection formed by courses or radials:

(1) **The angle of divergence** of the intersecting courses or radials shall not be less than 45°.

(2) **If the facility** which provides the crossing courses is NOT an NDB, it may be as much as 45 miles from the point of intersection.

(3) **If the facility which provides** the crossing course is an NDB, it must be within 30 miles of the intersection point.

(4) **If distances stated in paragraphs 287b(2) or (3) are exceeded,** the minimum angle of divergence of the intersecting courses must be increased at the following rate:

(a) If an NDB facility is involved, 1° for each mile over 30 miles.

(b) If an NDB facility is NOT involved, 1/2° for each mile over 45 miles.

FIGURE 30 DELETED BY CHG 19.

c. **FAF.** For a fix to be satisfactory for use as a FAF, the fix error should not exceed plus-or-minus 1 mile (see figures 31-1 and 31-2). It may be as large as plus-or-minus 2 miles when:

(1) The MAP is marked by overheading an air navigation facility (except 75 MHz markers); OR

(2) A buffer of equal length to the excessive fix error is provided between the published MAP and the point where the missed approach surface begins (see figure 32).

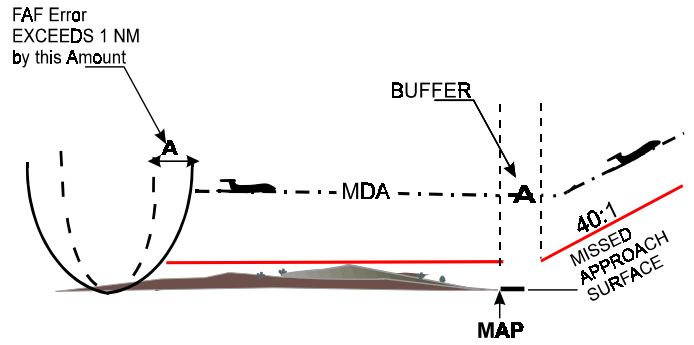

Figure 32. FAF ERROR BUFFER. Par 287c(2).

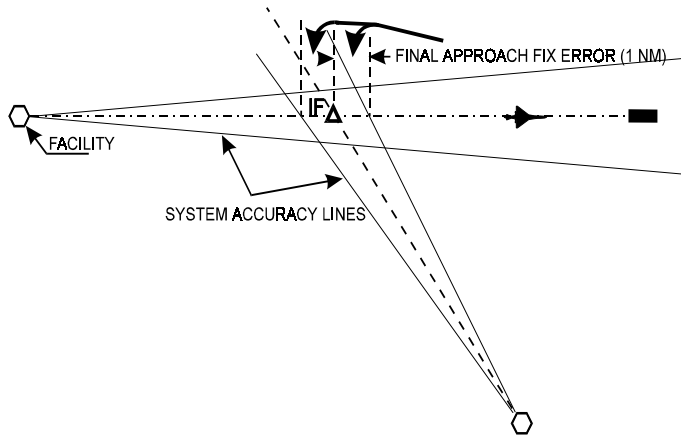
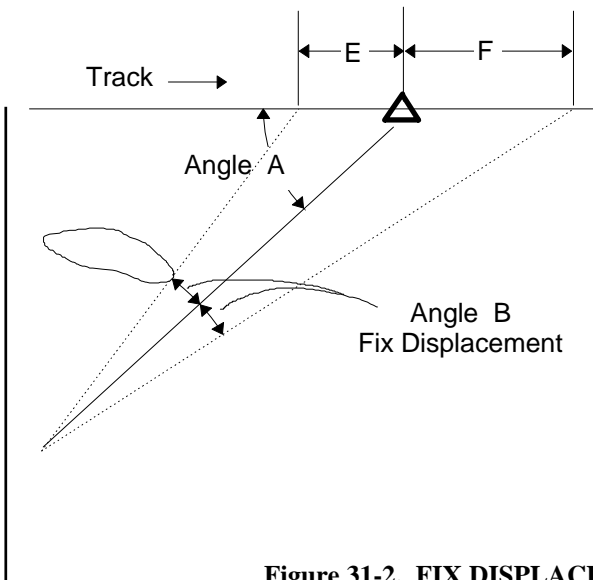

Figure 31-1. MEASUREMENT OF FAF ERROR. Par 287c.

Calculate fix displacement using the following formulas:



<u>Formula</u>	<u>Example</u>
$E = \frac{6076.11548 \times D \times \sin B}{\sin(A+B)}$	$E = \frac{6076.11548 \times 30 \times \sin 3.6^\circ}{\sin(50^\circ + 3.6^\circ)}$
	E = 14220.10
$F = \frac{6076.11548 \times D \times \sin B}{\sin(A-B)}$	$F = \frac{6076.11548 \times 30 \times \sin 3.6^\circ}{\sin(50^\circ - 3.6^\circ)}$
	F = 15805.19

Figure 31-2. FIX DISPLACEMENT CALCULATIONS. Par 287c.

288. USING FIXES FOR DESCENT.

a. Distance Available for Descent. When applying descent gradient criteria applicable to an approach segment (initial, intermediate or final approach areas), the measuring point is the plotted position of the fix (see figure 33).

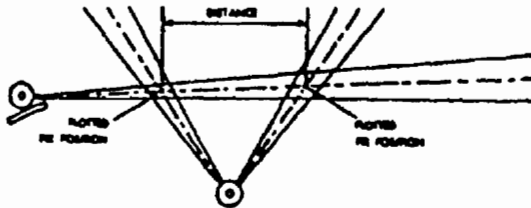

Figure 33. DISTANCE FOR DESCENT GRADIENT APPLICATION. Par 288a.

b. Obstacle Clearance After Passing a Fix. It is assumed that descent will begin at the earliest point the fix can be received. Full obstacle clearance shall be provided from this point to the plotted point of the next fix. Therefore, the altitude to which descent is to be made at the fix must provide the same clearance over obstacles in the fix displacement area as it does over those in the approach segment which is being entered (see figures 34-1 and 34-2).

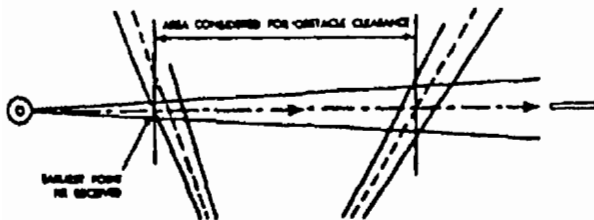
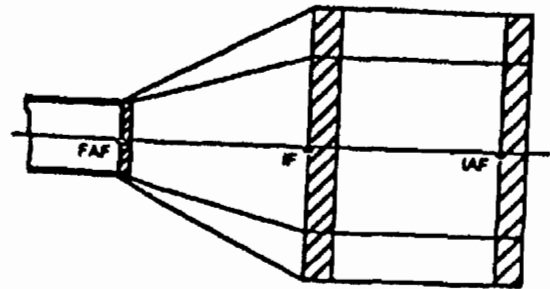
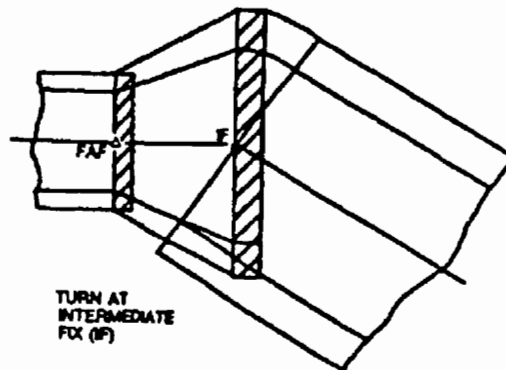

Figure 34-1. OBSTACLE CLEARANCE AREA BETWEEN FIXES. Par 288b.



STRAIGHT INITIAL, INTERMEDIATE, AND FINAL SEGMENTS.



TURN AT INTERMEDIATE FIX (IF)

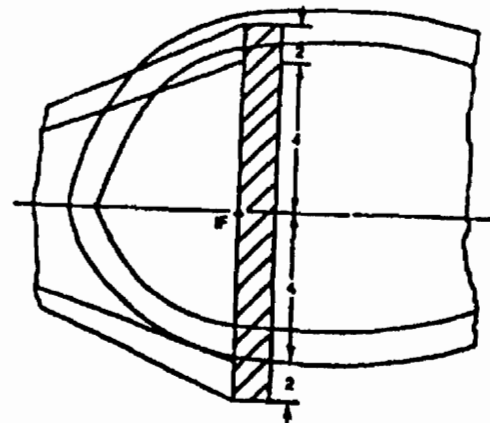

Figure 34-2. CONSTRUCTION OF FIX DISPLACEMENT AREA FOR OBSTACLE CLEARANCE. Par 288b.

c. Stepdown Fixes. See figure 35.

(1) **DME, Along Track Distance (ATD) or Radar Fixes.** Except in the intermediate segment within a procedure turn (paragraph 244), there is no maximum number of stepdown fixes in any segment when DME, an ATD fix, or radar is used. DME and ATD fixes may be denoted in tenths of a mile. The distance between fixes shall not be less than 1 mile.

(2) Intersection Fixes.

(a) Only one stepdown fix is permitted in the final and intermediate segments.

(b) If an intersection fix forms a FAF, IF, or IAF:

1 The same crossing facility shall be used for the stepdown fix(es) within that segment.

2 All fixes from the IF to the last stepdown fix in final shall be formed using the same crossing facility.

(c) Table 5A shall be used to determine the number of stepdown fixes permitted in the initial segment. The distance between fixes shall not be less than 1 mile.

(3) **Altitude at the Fix.** The minimum altitude at each stepdown fix shall be specified in 100-foot increments, except the altitude at the last stepdown fix in the final segment may be specified in a 20-foot increment.

(4) In the Final Segment:

(a) A stepdown fix shall not be established unless a decrease of at least 60 feet in MDA or a reduction in visibility minimums is achieved.

(b) The last stepdown fix error shall not exceed plus-or-minus 2 NM or the distance to the MAP, whichever is less. The fix error for other stepdown fixes in final shall not exceed 1 NM.

(c) Minimums shall be published both with and without the last stepdown fix, except for procedures requiring DME or NDB procedures which use a VOR radial to define the stepdown fix.

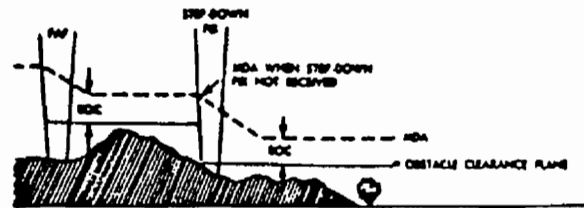

Figure 35. FINAL SEGMENT STEPDOWN FIX. Par 288c.

Table 5A. STEPDOWN FIXES IN INITIAL SEGMENT. Par 288c(2)(c).

Length of Segment	Number of Fixes
5-10 NM	1 stepdown fix
over 10-15 NM	2 stepdown fixes
over 15 NM	3 stepdown fixes

289. OBSTACLES CLOSE TO A FINAL APPROACH OR STEPDOWN FIX. Existing obstacles close to the FAF/stepdown fix may be eliminated from consideration if the following conditions are met:

a. The obstacle is in the final approach trapezoid within 1 NM past the point the FAF/stepdown fix can first be received, and...

b. The obstacle does not penetrate a 7:1 obstacle identification surface (OIS). The surface begins at the earliest point the fix can be received and extends toward the MAP 1 NM. The beginning surface height is determined by subtracting the final segment ROC (and adjustments from paragraphs 323a, b, or c, as applicable) from the minimum altitude required at the fix. The surface slopes downward 1 foot vertically for each 7 feet horizontally toward the MAP.

c. Obstacles eliminated from consideration by application of this paragraph shall be noted on the procedure.

d. The following formulas may be used to determine the OIS height at the obstacle or the minimum fix altitude based on applying the surface to an obstacle which must be eliminated.

Policy
Memo
Dec 28
2007

Fix Alt = MSL altitude at the fix (round up IAW 288c.(3))
 Obst Dist = Distance from earliest fix reception to obstacle
 ROC = Required Obstacle Clearance + adjustments
 Obst Elev = MSL obstacle elevation

$$OISheight = FixAlt - ROC - \left[\frac{Obst Dist}{7} \right]$$

$$MinFixAlt = ObstElev + ROC + \left[\frac{Obst Dist}{7} \right]$$

See figure 36. To determine fix error, see paragraphs 284, 285, and 286.

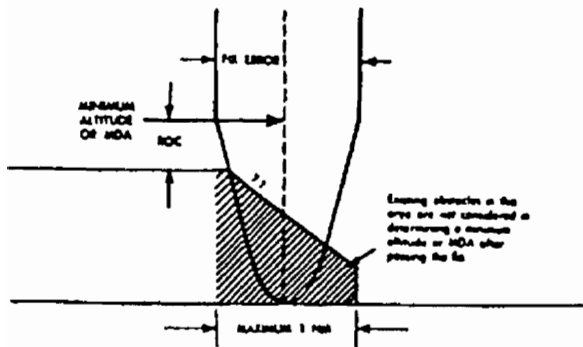

FIGURE 36. OBSTACLES CLOSE-IN TO A FIX. Par 289.

SECTION 9. HOLDING

290. HOLDING PATTERNS. Criteria for holding pattern airspace are contained in FAA Order 7130.3, and provide for separation of aircraft from aircraft. The criteria contained herein deal with the clearance of holding aircraft from obstacles.

291. ALIGNMENT. Whenever practical, holding patterns should be aligned to coincide with the flight course to be flown after leaving the holding fix. However, when the flightpath to be flown is along an arc, the holding pattern should be aligned on a radial. When a holding pattern is established at a FAF and a PT is not used, the inbound course of the holding pattern shall be aligned to coincide with the FAC unless the FAF is a facility. When the FAF is a facility, the inbound holding course and the FAC shall not differ by more than 30°.

292. AREA.

a. The primary obstacle clearance area shall be based on the appropriate holding pattern area specified in FAA Order 7130.3.

b. No reduction in the pattern sizes for 'on-entry' procedures is permitted.

c. Pattern number 4 is the minimum size authorized.

d. When holding is at an intersection or RNAV fix, the selected pattern shall be large enough to contain at least 3 corners of the fix displacement area. See paragraphs 284 and 285 and figure 37-1.

e. When paragraph 293b is used, the primary holding area shall encompass the departure or missed approach segment width at the holding fix (see figure 37-2).

f. A secondary area 2 miles wide surrounds the perimeter of the primary area

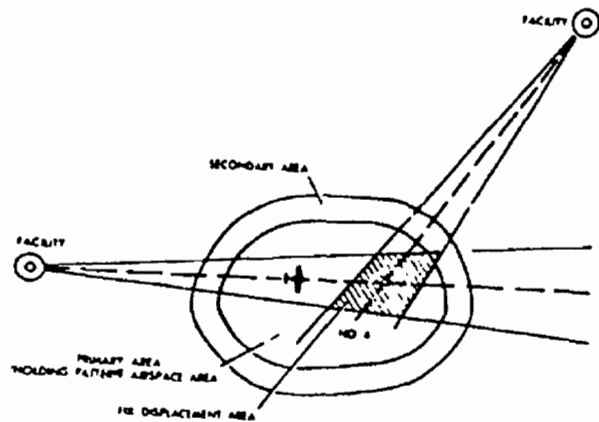

FIGURE 37-1. HOLDING PATTERN TEMPLATE APPLICATION. Par 292.

293. OBSTACLE CLEARANCE.

a. Level Holding. A minimum of 1,000 feet of obstacle clearance shall be provided throughout the primary area. In the secondary area 500 feet of obstacle clearance shall be provided at the inner edge, tapering to zero feet at the outer edge. For computation of obstacle clearance in the secondary area see paragraph 232c. Allowance for precipitous terrain should be considered as stated in paragraph 323a. The altitudes selected by application of the obstacle clearance specified in this paragraph may be rounded to the nearest 100 feet. See paragraph 231.

b. Climbing in a Holding Pattern. When a climb in hold is used, as in a departure or missed approach, no

Policy Memo Dec 28 2007

obstacle shall penetrate the holding surface. This surface begins at the end of the segment leading to the holding fix. Its elevation is that of the departure OIS or missed approach surface at the holding fix. It rises at a 40:1 rate to the edge of the primary area, then at a 12:1 rate to the outer edge of the secondary area. The distance to any obstacle is measured from the obstacle to the nearest point on the end of the segment at the holding fix. See figure 37-2 and FAA Order 7130.3, paragraph 35.

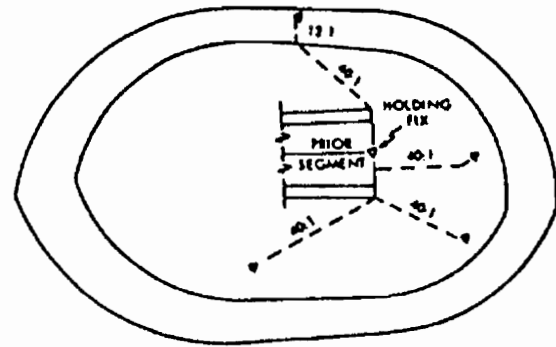

FIGURE 37-2. CLIMBING IN A HOLDING PATTERN. Par 293b.

294. - 299. RESERVED.

Order 8260.3B, Volume 1, Chapter 2
Formulas Addendum

Paragraph 252a Formula *Calculating Straight-in Descent Angle*

$$\theta_{\text{DESCENT}} = \text{atan} \left(\ln \left(\frac{r + \text{alt}}{r + \text{THRe} + \text{TCH}} \right) \cdot \frac{r}{D_{\text{FIX}}} \right) \cdot \frac{180}{\pi}$$

Where:

atan = arc tangent

ln = Natural logarithm

alt = FAF/PFAF or stepdown fix altitude

THRe= Threshold elevation

r = 20890537

TCH = VGSI or Design TCH

D_{FIX} = Distance (ft) from FAF/PFAF or stepdown fix to FEP

$$\text{atan}(\ln((r+\text{alt})/(r+\text{THRe}+\text{TCH}))*r/D_{\text{FIX}})*180/\pi$$

Calculator

<i>alt</i>		Click here to calculate
<i>THRe</i>		
<i>r</i>	20890537	
<i>TCH</i>		
<i>D_{FIX}</i>		
θ_{DESCENT}		

Back

Figure 14.5 Formula *Straight-in FAF/PFAF or Stepdown fix Distance based on Altitude and Angle (Par 252a)*

$$D_{PFAF} = \frac{\ln\left(\frac{r + alt}{r + THRe + TCH}\right) \cdot r}{\tan\left(\theta \cdot \frac{\pi}{180}\right)}$$

Where:

- In = Natural logarithm
- alt = Minimum FAF/PFAF or stepdown fix altitude
- THRe = Threshold elevation
- TCH = VGSI or Design TCH
- tan = tangent
- r = 20890537
- θ = VGSI or specified descent angle

$$(Ln((r+alt)/(r+THRe+TCH))*r)/tan(\theta*\pi/180)$$

Calculator

<i>alt</i>	<input type="text"/>	Click here to calculate
<i>THRe</i>	<input type="text"/>	
<i>TCH</i>	<input type="text"/>	
<i>r</i>	20890537	
<i>θ</i>	<input type="text"/>	
<i>D_{PFAF}</i>	<input type="text"/>	
Back		

Paragraph 252b Formula Calculating Circling Descent Angle

$$\theta_{\text{CIRCLEDESCENT}} = \text{atan} \left(\ln \left(\frac{r + \text{alt}}{r + \text{CMDA}} \right) \cdot \frac{r}{D_{\text{FIX}}} \right) \cdot \frac{180}{\pi}$$

Where:

atan = arc tangent

ln = Natural logarithm

r = 20890537

alt = FAF/PFAF or Stepdown fix altitude

CMDA = Lowest Published CMDA

D_{FIX} = Distance (ft) from FAF/PFAF or stepdown fix to FEP

$$\text{atan}(\ln((r+\text{alt})/(r+\text{CMDA}))*r/D_{\text{FIX}})*180/\pi$$

Calculator

<i>alt</i>	<input type="text"/>	Click here to calculate
<i>CMDA</i>	<input type="text"/>	
<i>r</i>	20890537	
<i>D_{FIX}</i>	<input type="text"/>	
$\theta_{\text{CIRCLEDESCENT}}$	<input type="text"/>	

Back

Paragraph 252c Formula *Determining Altitude of Vertical Path at a Stepdown Fix*

$$Z_{\text{vertpath}} = e^{\frac{D_z \cdot \tan\left(\theta \cdot \frac{\pi}{180}\right)}{r}} \cdot (r + \text{base}_{\text{alt}}) - r$$

Where:

e = base of the natural logarithm (Napier's constant)

D_z = dist (ft) from FEP to fix

tan = tangent

θ = angle calculated IAW 252a or 252b

r = 20890537

base_{alt}

(para. 252a) = THRe + TCH

(para. 252b) = CMDA

$$e^{((DZ * \tan(\theta * \pi / 180)) / r) * (r + \text{base}_{\text{alt}})} - r$$

Calculator

D _z		Click here to calculate
θ		
r	20890537	
base _{alt}		
Z _{vertpath}		

Back

Paragraph 253 Formula Calculating VDP distance

$$D_{VDP} = r \cdot \left(\frac{\pi}{2} - \theta \cdot \frac{\pi}{180} - \text{asin} \left(\frac{\cos \left(\theta \cdot \frac{\pi}{180} \right) \cdot (r + \text{THRe} + \text{TCH})}{r + \text{MDA}} \right) \right)$$

Where:

- asin = arc sine
- cos = cosine
- θ = VGSI or specified descent angle
- r = 20890537
- THRe = Threshold elevation
- TCH = VGSI or Design TCH
- MDA = Minimum Descent altitude

$$r * (\pi/2 - \theta * \pi/180 - \text{asin}((\cos(\theta * \pi/180) * (r + \text{THRe} + \text{TCH})) / (r + \text{MDA})))$$

Calculator

<i>MDA</i>		Click here to calculate
<i>THRe</i>		
<i>TCH</i>		
<i>r</i>	20890537	
<i>θ</i>		
<i>D_{VDP}</i>		

Back

Paragraph 260 Formula #1 True Airspeed

$$V_{KTAS} = \frac{V_{KIAS} \cdot 171233 \cdot \sqrt{(288 + 15) - 0.00198 \cdot (alt + k)}}{(288 - 0.00198 \cdot (alt + k))^{2.628}}$$

Where:

- V_{KIAS} = indicated airspeed (from table 4)
- alt = airport elevation (MSL)
- k = height above airport (1,000 ft minimum)

$$(VKIAS*171233*((288+15)-0.00198*(alt+k))^0.5)/(288-0.00198*(alt+k))^2.628$$

Calculator

V_{KIAS}	<input type="text"/>	Click here to calculate
alt	<input type="text"/>	
k	<input type="text"/>	
V_{KTAS}	<input type="text"/>	

Back

Paragraph 260 Formula #2 Circling Approach Area Radius

$$CAR = 2 \cdot \frac{(V_{KTAS} + 25)^2}{\tan(\text{bank}_{\text{angle}} \cdot \frac{\pi}{180}) \cdot 68625.4} + S$$

Where:

- V_{KTAS} = true airspeed
- tan = tangent
- bank_{angle} = achieved bank angle (from table 4)
- S = straight segment (from table 4)

$$2 * (V_{KTAS} + 25)^2 / (\tan(\text{bankangle} * \pi / 180) * 68625.4) + S$$

Calculator

V_{KTAS}	<input type="text"/>	Click here to calculate
Bank _{angle}	<input type="text"/>	
S	<input type="text"/>	
CAR	<input type="text"/>	

Back

THIS PAGE INTENTIONALLY LEFT BLANK

Chapter 3. Takeoff and Landing Minimums.

Section One. General Information.

3.0 Application.

The minimums specified in this chapter are the lowest that can be approved through TERPS application at any location for the type of navigation facility concerned. Category (CAT) II/III visibility minima calculation methods and elements are located in *Volume 3, appendix 1*.

3.1 Establishment.

Establish the lowest minimums permitted by the criteria contained in this order. Specify minimums for each condition indicated in the procedure; i.e., straight-in, circling, alternate, and takeoff, as required. List the following minima elements: decision altitude (DA), decision height (DH), minimum descent altitude (MDA), height above threshold (HATh), height above airport (HAA), height above landing (HAL), or height above surface (HAS) as appropriate, and runway visual range (RVR) or visibility. Alternate minimums, when specified, shall be stated as ceiling and visibility. Specify takeoff minimums when required, as visibility only, except where the need to see and avoid an obstacle requires the establishment of a ceiling value. DoD may specify alternate and takeoff minimums in separate directives.

Note: Ceiling = (DA/MDA - Airport Elevation) rounded to next higher 100 ft increment. For example, DA 1242 – Airport Elevation 214 = 1028 = Ceiling 1,100 ft.

3.1.1 Publication.

- 3.1.1 a. Publish minimums for each approach category** accommodated at the airport. Approach category E minimums should be published at civil/joint-use airports only where a valid DoD requirement exists. Minimums for DoD procedures are published as prescribed by the appropriate DoD service.

Note: Do not base the decision to restrict straight-in minima to specific approach categories solely on the Airport Reference Code (ARC) designation of the runway. The ARC system described in Advisory Circular (AC) 150/5300-13, Airport Design, is primarily intended to establish runway infrastructure requirements. The ARC designation is not meant to determine the set of approach categories to publish in a procedure landing minima. This decision is made on a case-by-case basis through Regional Airspace and Procedures Team (RAPT) coordination or by appropriate DoD authority, and must accommodate the approach speed of all aircraft expected to utilize the procedure. ARC code/supporting infrastructure should be considered when determining authorized approach categories when the RAPT determines it is appropriate for safe operations.

3.1.1 b. Annotate the chart appropriately when one or more approach categories are not authorized. Publish minima for each approach category except those not authorized (e.g., publish only category A and B straight-in minimums when categories C and D are not authorized).

3.1.2 Runway Visual Range (RVR).

RVR is a system of measuring the visibility along the runway. An instrumentally derived value, it represents the horizontal distance a pilot will see down the runway from the approach end. RVR is based on the sighting of either high intensity runway lights or the visual contrast of other targets, whichever yields the greater visual range.

3.1.2 a. Runway Requirements for RVR Approval.

RVR may be published with straight-in landing minima when:

3.1.2 a. (1) RVR equipment is installed to the runway in accordance with the applicable standard (e.g., FAA Standard 008 or appropriate DoD directive).

3.1.2 a. (2) High Intensity Runway Lights are installed to the runway in accordance with appropriate FAA or DoD standards.

3.1.2 a. (3) Runway marking and lighting is appropriate for the intended use. Precision approaches, approaches with vertical guidance (APV), and most nonprecision approach (NPA) procedures require instrument runway markings or touchdown zone and center-line lighting (TDZ/CL). When required runway markings are not available but TDZ/CL is available, RVR equal to the visibility minimum appropriate for the approach light configuration is authorized. See AC 150/5300-13 and AC 150/5340-1, *Standards for Airport Markings*, for further information.

3.1.3 Approach Lighting Systems.

Approach lighting systems extend visual cues to the approaching pilot and make the runway environment apparent with less visibility than when such lighting is not available. For this reason, lower straight-in (not applicable to circling) visibility minimums may be established when standard or equivalent approach lighting systems are present.

3.1.3 a. Standard Lighting Systems.

Table 3-1 provides the types of standard approach and runway lighting systems, as well as the operational coverage for each type. *Table 3-2* provides United States and international lighting system classifications.

Policy
Memo
Dec 29
2011

Table 3-1. Standard Lighting Systems.			
	APPROACH LIGHTING SYSTEMS	Operational Coverage (°)	
		Lateral (±)	Vertical (above horizon)
ALSF-1	Standard Approach Lighting System with Sequenced Flashers	21.0* 12.5#	12.0* 12.5#
ALSF-2	Standard Approach Lighting System with Sequenced Flashers & CAT II Modification	21.0* 12.5#	12.0* 12.5#
SALS	Short Approach Lighting System	21.0* --	12.0* --
SALSF	Short Approach Lighting System with Sequenced Flashers	21.0* 12.5#	12.0* 12.5#
SSALS	Simplified Short Approach Lighting System	21.0* --	12.0* --
SSALF	Simplified Short Approach Lighting System with Sequenced Flashers	21.0* 12.5#	12.0* 12.5#
SSALR	Simplified Short Approach Lighting System with Runway Alignment Indicator Lights	21.0* 12.5#	12.0* 12.5#
MALS	Medium Intensity Approach Lighting System	10.0* --	10.0* --
MALSF	Medium Intensity Approach Lighting System with Sequenced Flashers	10.0* 12.5#	10.0* 12.5#
MALSR	Medium Intensity Approach Lighting System with Runway Alignment Indicator Lights	10.0* 12.5#	10.0* 12.5#
ODALS	Omni-Directional Approach Lighting System	360#	2.0-10.0#

** Steady-burning # Sequenced flashers*

RUNWAY LIGHTING SYSTEMS	
HIRL	High Intensity Runway Lights
MIRL	Medium Intensity Runway Lights
LIRL	Low Intensity Runway Lights
TDZ/CL	Touchdown Zone and Centerline Lights

Note: See Order 8260.3B, Volume 3, appendix 5 for lighting system descriptions.

Table 3-2. United States and International Approach Lighting Classifications.		
Facility Class	Approach Lighting Systems (ALS)	ALS Length (ft)
Full (FALS)	ALS length ≥ 720 m	≥ 2400
	U.S.: ALSF-1, ALSF-2, SSALR, MALSR High or medium intensity and/or flashing lights ICAO: Calvert or Barette Centre Line Lights, high intensity lights	
Intermediate (IALS)	ALS length 420 - 719 m	$\geq 1400 - 2399$
	U.S.: MALSF, MALS, SSALF, SSALS, SALS/SALSF High or medium intensity and/or flashing lights ICAO: Simplified Approach Light System, high intensity lights	
Basic (BALS)	ALS length 210 - 419 m	$\geq 700 - 1399$
	U.S.: ODALS High or medium intensity lights and/or flashing lights JAA: High, medium or low intensity lights, including one crossbar	
Nil (NALS)	ALS length < 210 m, or No approach lights	None or < 700

3.1.3 b. Operational Conditions.

In order to apply approach light credit (e.g., publish visibility from the FALS, IALS, or BALS column from *table 3-5a, 3-6, or 3-7*), the following conditions must exist:

- 3.1.3 b. (1) The runway must have nonprecision instrument or precision instrument (all-weather) markings or TDZ/CLs as specified in directives of the appropriate approving authority. Unless otherwise authorized by Flight Standards, precision instrument runway markings are required in order to publish visibility less than 3/4 statute miles (SM). Runway marking effectiveness may be degraded when obscured by surface water, snow, ice, or tire marks. All procedures to the affected runway must revert to no-light minimums when required markings are removed, or when it is determined the markings are inadequate for reduced visibility credit. Operational TDZ/CL lights may be substituted for removed, deteriorated, or obscured runway markings to authorize a visibility minimum appropriate for the applicable approach light configuration.**
- 3.1.3 b. (2) The final approach course (FAC) must place the aircraft within the lateral and vertical coverage of the approach lighting system at a distance from the landing threshold equal to the standard visibility required without lights (NALS column) AND the distance from MAP/DA to threshold must be less than or equal to 3 SM.**

Note: The straight-in (SI) FAC to an "on-airport" facility typically transits all approach light operational areas within the visibility arc limits, but the FAC from

an “off-airport” facility may be restricted to a standard approach light system (ALSF) or short approach lighting system (SALS) for visibility credit. See figure 3-1.

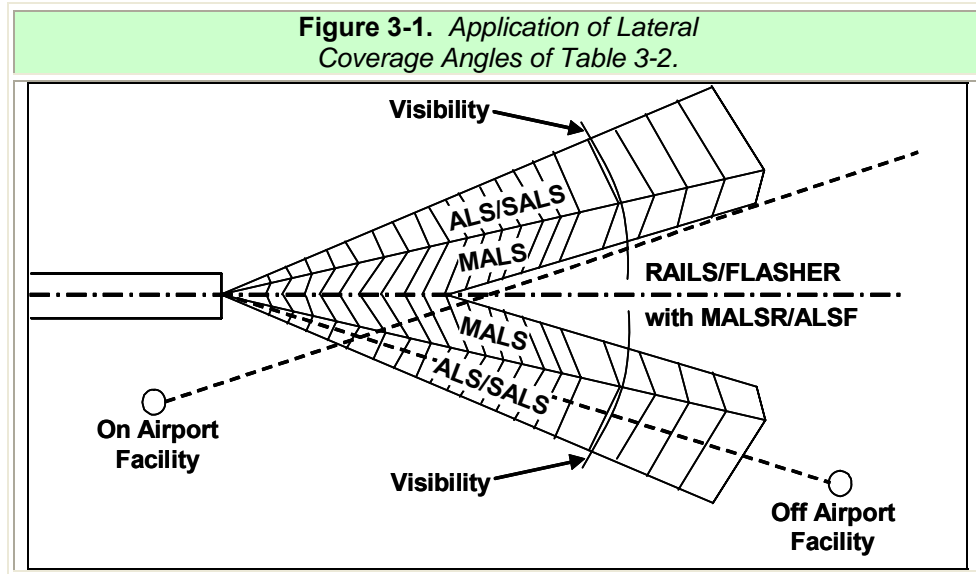

3.1.3 b. (3) For PA and APV procedures, the TCH must not exceed the upper limit value specified by *table 3-3*.

3.1.3 c. Other Lighting Systems.

Standard system variations, and other systems not included in this chapter, must meet the specified operational conditions in *paragraph 3.1.3.b* to receive visibility reduction credit. The provisions of *TERPS Volume 1, paragraph 141*, govern civil airport lighting systems which do not meet known standards, or for which criteria does not exist. DoD lighting systems may be equated to standard systems for visibility reduction, as illustrated in *appendix 5*. Where existing systems vary from *appendix 5* configurations and cannot be equated to a standard system, consult the appropriate approving authority for special consideration.

Table 3-3. PA/APV Threshold Crossing Height Upper Limits for Allowing Visibility Credit for Authorized Lighting Systems.					
HATh (Feet)	GLIDEPATH ANGLE (Degrees)	TCH UPPER LIMIT (Feet)	HATh (Feet)	GLIDEPATH ANGLE (Degrees)	TCH UPPER LIMIT (Feet)
* 200 to 249	# 2.50 - 3.20	75	300 to 349	# 2.50 - 4.90	75
	3.21 - 3.30	70		4.91 - 5.00	71
	3.31 - 3.40	66		5.01 - 5.10	66
	3.41 - 3.50	63		5.11 - 5.20	61
	3.51 - 3.60	59		5.21 - 5.30	56
	3.61 - 3.70	55		5.31 - 5.40	52
	3.71 - 3.80	50		5.41 - 5.50	48
	3.81 - 3.90	47		5.51 - 5.60	43
	3.91 - 4.00	43		5.61 - 5.70	39
	4.01 - 4.10	39			
4.11 - 4.20	35				
250 to 269	# 2.50 - 4.10	75	350 and above	# 2.50 - 5.60	75
	4.11 - 4.20	71		5.61 - 5.70	70
	4.21 - 4.30	67		5.71 - 5.80	65
	4.31 - 4.40	62		5.81 - 5.90	60
	4.41 - 4.50	58		5.91 - 6.00	55
	4.51 - 4.60	54		6.01 - 6.10	50
	4.61 - 4.70	50		6.11 - 6.20	45
	4.71 - 4.80	45		6.21 - 6.30	40
	4.81 - 4.90	41		6.31 - 6.40	35
	4.91 - 5.00	37			
270 to 299	# 2.50 - 4.40	75			
	4.41 - 4.50	73			
	4.51 - 4.60	68			
	4.61 - 4.70	64			
	4.71 - 4.80	59			
	4.81 - 4.90	55			
4.91 - 5.00	51				

* 100 ft – 199 ft HATh for DoD PAR only

GPA < 3.0 DoD only

Chapter 3. Takeoff and Landing Minimums.
Section Two. Establishing Minimum Altitudes/Heights.

3.2 Establish minimum altitudes/heights for each authorized approach CAT.

3.2.1 Minimums altitudes/heights types are:

3.2.1 a. Decision Altitude (DA). A DA is a specified minimum altitude (feet MSL) in a PA or APV instrument approach procedure at which the pilot must decide whether to initiate an immediate missed approach if they do not see the required visual references or to continue the approach. Determine the DA using the appropriate criteria and round the published value to the next higher 1-ft increment (234.10 rounds to 235).

3.2.1 b. Decision Height (DH). RESERVED.

3.2.1 c. Radio Altimeter (RA). See current CAT II/III ILS guidance.

3.2.1 d. Minimum Descent Altitude (MDA). MDA represents the final approach minimum altitude for NPA instrument approach procedures. Each published MDA shall be expressed in feet MSL rounded to the next higher 20-ft increment. Apply criteria as specified by the applicable chapter/criteria to determine the MDA.

3.2.1 d. (1) Each straight-in (SI) approach MDA must provide at least the minimum Final Approach Segment (FAS) and Missed Approach Segment (MAS) Required Obstacle Clearance (ROC) as specified by the applicable chapter/criteria.

3.2.1 d. (2) Each circling MDA (CMDA) HAA must be no lower than that specified in paragraph 3.3.3 and table 3-9. Each CMDA must provide the minimum ROC in the circling maneuvering area and meet the missed approach requirements specified in paragraph 3.2.1d(1). Each published CMDA must provide the minimum required final obstacle clearance in the final approach segment and the minimum required circling obstacle clearance in the circling approach area. Each CMDA must not be above the PFAF altitude and, when applicable, below the straight-in MDA (same CAT) for the highest line of NPA minima on the same chart.

Note: When dual minimums are authorized, the CMDA is compared against the SI MDA associated with the corresponding minima set (i.e., circling with stepdown minimums checked against SI with stepdown minimums).

3.2.2 Adjustments to Minimum Altitudes/Heights. The MDA or DA/H may require an increase under the conditions described below:

3.2.2 a. For PA/APV approaches, determine the minimum HATh based on glidepath angle for each aircraft category using table 3-4.

Table 3-4. Minimum HATh for PA and APV Approach Procedures.

Glidepath Angle	Aircraft Category			
	A	B	C	D & E
2.50° - 2.99° (Military only)	200 ^{1,2}			
3.00° - 3.10°	200 ^{1,2,4}			
3.11° - 3.30°	200 ^{2,4}		250	Not authorized ⁵
3.31° - 3.60°	200 ^{2,3,4}		270 ⁴	Not authorized ⁵
3.61° - 3.80°	200 ^{2,3,4}		Not authorized	
3.81° - 4.20°	200 ^{3,4}	250	Not authorized	
4.21° - 5.00°	250	Not authorized		
5.01° - 5.70°	300	Not authorized		
5.71° - 6.40°	350	Not authorized		
Airspeed NTE 80 knots				

1. PAR minimum HATh = 100 (Military only)
2. LNAV/VNAV and RNP SAAAR minimum HATh = 250
3. LPV w/GPA > 3.5° = 250
4. LDA w/GS = 250
5. USN = 250

3.2.2 b. Precipitous terrain adjustments. In areas characterized by precipitous terrain, in or outside of designated mountainous areas, consideration must be given to induced altimeter errors and pilot control problems. Evaluate and identify terrain as precipitous or non-precipitous using software implementing the FAA-approved algorithms developed for this purpose (not applicable to USAF).

Note: FAA precipitous terrain algorithms were designed to evaluate instrument approach feeder, initial, and final segments. Do not use software implementing these algorithms for other TERPS evaluations (e.g., radar vectoring altitude charts, TAA, or other evaluations not addressed in the June 18, 2004 AFS memorandum, subject Automated Precipitous Terrain Adjustments).

3.2.2 b. (1) Precipitous terrain identified in the final segment. For conventional NPA approaches, increase ROC values by the amount specified by the software/algorithms (USAF; by the amount deemed appropriate by the specialist/approving authority). For PA/non-Baro approaches that permit precipitous terrain in the final segment increase the HATh by 10 percent of the value determined by evaluation of the final and missed segments, e.g., 200 ft increases to 220 ft, 350 ft increases to 385 ft, and recalculate the DA. Do not include adjustments for RASS before determining the precipitous terrain adjustment.

Policy
Memo
08/17/09

- 3.2.2 b. (2) Precipitous terrain identified in other approach segments will not directly affect landing minimums, but will impact ROC/minimum altitudes in that segment.
- 3.2.2 b. (3) Precipitous terrain identified in feeder segments in a designated mountainous area. No increase is required, but ROC may not be reduced from 2000 ft (see Volume 1, chapter 17, paragraph 1720).
- 3.2.2 b. (4) Precipitous terrain identified in other segments. When the criteria applicable to the segment requires a precipitous terrain adjustment, increase ROC values by the amount specified by the software/algorithms. (USAF; by the amount deemed appropriate by the specialist/approving authority).
- 3.2.2 c. Remote Altimeter Setting Source (RASS).** Not applicable to minimum safe/sector altitude (MSAs), initials, en route, feeder routes, or segment/areas based on en route criteria. When the altimeter setting is obtained from a source more than 5 nautical miles (NM) from the Airport Reference Point (ARP) for an airport, or the Heliport Reference Point (HRP) for a heliport or vertiport, a RASS adjustment must be considered. A remote altimeter-setting source is not authorized for a remote distance greater than 75 NM or for an elevation differential between the RASS and the landing area that is greater than 6000 ft. To determine which formula to apply, evaluate the terrain between the RASS and the airport/heliport/vertiport for adverse atmospheric pressure pattern effect. Solicit the best available climatological information from the National Weather Service (NWS), the National Aviation Weather Advisory Unit (NAWAU), the Center Weather Service Unit (CWSU), and the local Flight Service Station (FSS).

Note: When a secondary altimeter source must be specified AND either the primary or secondary altimeter source (or both) is considered remote, establish separate landing minima. If establishing separate minima is impractical, publish a chart note specifying the difference between the MDA or DA for primary and secondary sources.

- 3.2.2 c. (1) Where intervening terrain does not adversely influence atmospheric pressure patterns, use formula 3-1a to compute the basic RASS adjustment in feet. See figure 3-1a.

Figure 3-1a. Basic RASS adjustment (no intervening terrain).

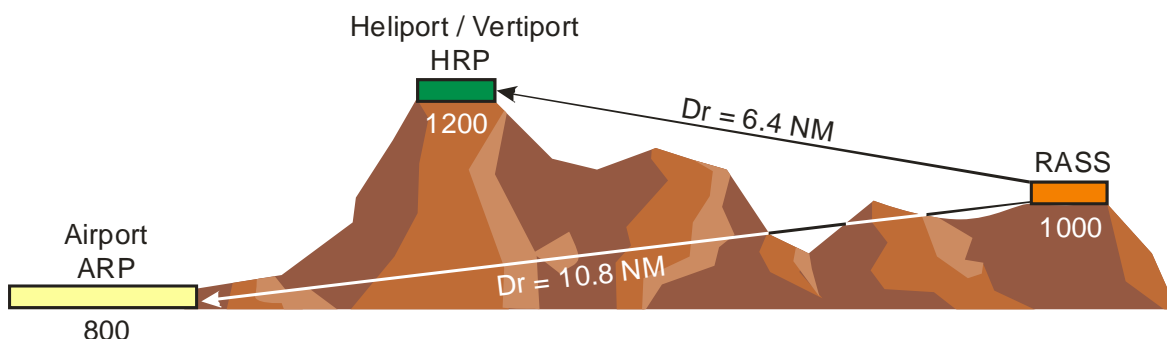

Formula 3-1a. Basic RASS Adjustment (no Intervening terrain).

$$\text{Adjustment} = 2.30 D_r + 0.14 E_1$$

Where D_r = horizontal dist (NM) altimeter source to ARP/HRP*
 E_1 = elevation differential (feet) between RASS
 elevation and airport/heliport/vertiport elevation

* Copter PinS Approaches. When annotated "Proceed Visually": D_r = Horizontal distance from altimeter source to HRP. When annotated "Proceed VFR": D_r = Horizontal distance from altimeter source to MAP

Examples:Airport

$$D_r = 10.8 \text{ NM}$$

$$E_1 = 1000 - 800 = 200 \text{ ft}$$

$$(2.30 * 10.8) + (0.14 * 200) = 52.84 \text{ ft basic RASS adjustment}$$

In intermediate segment: $52.84 * 0.6 < 200$ (no ROC increase)

In PA/APV final segment: DH = $200 + 52.84$ = increase DH to 253

In NPA final segment: 1225 (Controlling obs) + 250 ROC + 52.84 = 1540 MDA

Helicopter

$$D_r = 6.4 \text{ NM}$$

$$E_1 = 1200 - 1000 = 200 \text{ ft}$$

$$(2.30 * 6.4) + (0.14 * 200) = 42.72 \text{ ft basic RASS adjustment}$$

In intermediate segment $42.72 * 0.6 < 200$ (no ROC increase)

In PA/APV final segment: DH = $200 + 42.72$ = increase DH to 243

In NPA final segment: 1225 (Controlling obs) + 250 ROC + 42.72 = 1520 MDA

3.2.2 c. (2) Where intervening terrain adversely influences atmospheric pressure patterns, an Elevation Differential Area (EDA) must be evaluated. The EDA is defined as an area 5 NM each side of a line connecting the ARP/HRP and the RASS, and includes a circular area enclosed by a 5 NM radius at each end of this line. Use formula 3-1b to compute the basic RASS adjustment in feet. See figure 3-1b.

Formula 3-1b. Basic RASS Adjustment (Intervening Terrain)

$$\text{Adjustment} = 2.30 D_r + 0.14 E_2$$

Where D_r = horizontal dist (NM) altimeter source to ARP/HRP*
 E_2 = the elevation differential (feet) between lowest
 and highest elevation points within the EDA

* Copter PinS Approaches. When annotated "Proceed Visually": D_r = Horizontal distance from altimeter source to HRP. When annotated "Proceed VFR": D_r = Horizontal distance from altimeter source to MAP

Examples:Airport

$$D_r = 25 \text{ NM}$$

$$E_2 = 5800 - 800 = 5000 \text{ ft}$$

$$(2.30 * 25) + (0.14 * 5000) = 757.5 \text{ ft basic RASS adjustment}$$

In intermediate segment $757.5 * 0.6 = 454.5 - 200$ (254.5 ft ROC increase)

In PA/APV final segment: $DH = 350 + 757.5 =$ increase DH to 1108

In NPA final segment: 3052.2 (Controlling obs) + 250 ROC + 757.5 = 4060 MDA

Heliport

$$D_r = 15 \text{ NM}$$

$$E_2 = 5800 - 800 = 5000 \text{ ft}$$

$$(2.30 * 15) + (0.14 * 5000) = 734.5 \text{ ft basic RASS adjustment}$$

In intermediate segment $734.5 * 0.6 = 440.7 - 200$ (240.7 ft ROC increase)

In PA/APV final segment: $DH = 294 + 734.5 =$ increase DH to 1029

In NPA final segment: 6000 (Controlling obs) + 250 ROC + 734.5 = 7000 MDA

Figure 3-1b. Elevation Differential Area (EDA)
Intervening Terrain Influences Atmospheric Pressure Patterns

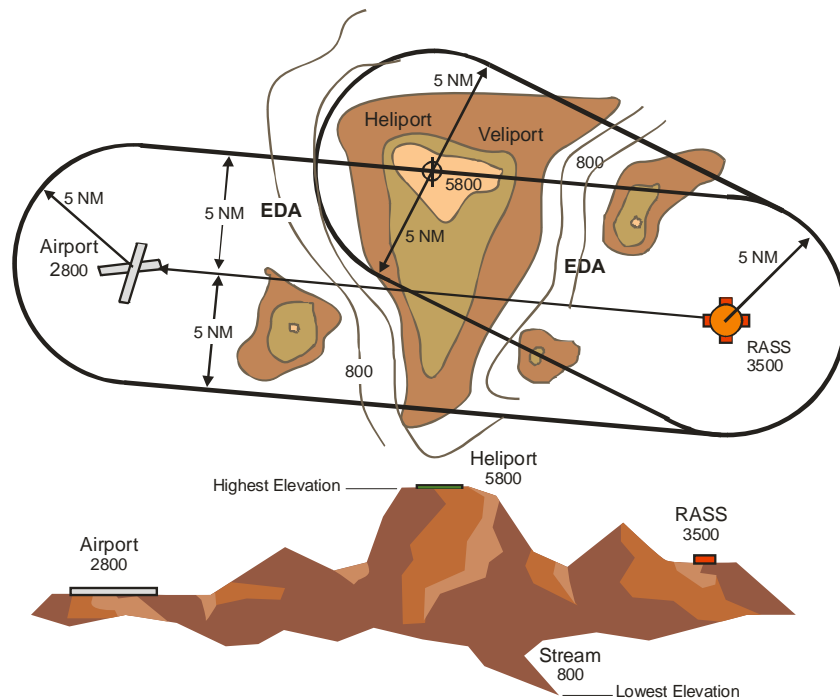

- 3.2.2 c. (3) NPA final segments (including the circling maneuvering area). Increase primary area ROC by the full basic RASS adjustment.
- 3.2.2 c. (4) PA/APV final segments. Increase the DA (prior to rounding) by the full basic RASS adjustment.

- 3.2.2 c. (5) For intermediate segments, use 60 percent of the basic RASS adjustment from formulas 3-1a or 3-1b and increase the intermediate segment primary area ROC by the amount this value exceeds 200 ft.
- 3.2.2 c. (6) When the missed approach design utilizes a turn at altitude prior to the clearance limit and a part-time altimeter source is specified, decrease the turning section Obstacle Clearance Surface (OCS) starting height by the difference between RASS adjustments for the two remote altimeter sources. (Where one altimeter source is local, subtract the full RASS adjustment.) Do not decrease these surface starting heights to less than the OCS at the missed approach point (MAP). If this results in an OCS penetration that cannot be resolved by other methods, provide a second climb-to-altitude determined by adding the difference between the RASS adjustments to the climb-to-altitude and rounding to the next higher appropriate increment. This application must not produce a turn altitude above the missed approach clearance-limit altitude.

Example: MISSED APPROACH: Climb to 6000 (6,100 when using Denver Intl altimeter setting) then...

Note: Combination straight-portion length extension is not required to accommodate the worst-case altimeter source.

- 3.2.2 c. (7) Helicopter Point in Space (PinS) Approach. When the MAP is more than 5 NM from the PinS approach altimeter-setting source for a PinS-VFR approach, or the HRP is more than 5 NM from altimeter-setting source for a PinS- Special IFR Approach to a VFR Heliport (IVH) approach, RASS adjustment must be applied. For application of the RASS formula, define “Dr” as the distance from the altimeter-setting source to the MAP/HRP accordingly, and define “E1”, or “E2”, as specified by formulas 3-1a or 3-1b whereas E1 = the heliport elevation for both PinS-IVH and PinS-VFR.
- 3.2.2 c. (8) Minimum Reception Altitude (MRA). Where a minimum altitude is MRA based, increase the MRA using the RASS adjustment factor value.
- 3.2.2 c. (9) Where the altimeter is based on a remote source(s), annotate the procedure and/or publish the appropriate minima lines in accordance with Order 8260.19, Flight Procedures and Airspace.

- 3.2.2 d. Excessive Length, Nonprecision Final Approach.** When a procedure incorporates a final approach fix (FAF), and the final approach segment (FAS) length FAF-to-MAP exceeds 6 NM (plotted positions), increase FAS primary area ROC 5 ft for each one-tenth NM over 6 NM.

EXCEPTION: If a stepdown fix exists and the remaining segment length is less than 6 NM, the basic FAS ROC may be applied between the stepdown fix and the MAP. See formula 3-2 (Excessive Length Adjustment).

Formula 3-2. Excessive Length Adjustment

$$\text{Adjustment} = 50(\text{Length}_{\text{final}} - 6)$$

Where $\text{Length}_{\text{final}}$ = horizontal distance in NM from plotted position of FAF to MAP

$$50 * (\text{Length}_{\text{final}} - 6)$$

Example

$$\text{Distance FAF to MAP} = 6.47$$

$$\text{Adjustment} = 50(6.47 - 6) = 23.5$$

$$250 \text{ ROC} + 23.5 = 273.5 \text{ adjusted ROC}$$

Chapter 3. Takeoff and Landing Minimums

Section Three. Visibility Minimums

3.3 Visibility Minimums.

3.3.1 Authorization.

3.3.1 a. Straight-in visibility minimums are authorized when:

3.3.1 a. (1) Applicable straight-in alignment standards are met, and

3.3.1 a. (2) The final approach segment vertical descent angle does not exceed tolerances [see paragraph 252].

3.3.1 b. Circling visibility minimums are authorized when:

3.3.1 b. (1) Straight-in alignment cannot be met (e.g., for “Circling-only” procedures not meeting straight-in alignment requirements) [see paragraph 162].

3.3.1 b. (2) Straight-in alignment requirements are met, but descent angle precludes publication of straight-in minimums [see paragraph 252].

3.3.1 b. (3) Published in conjunction with straight-in minimums.

Note: Do not establish circling minima when PA or APV procedures are established without accompanying SI NPA minima.

3.3.2 Establishing Straight-in Visibility Minimums. Establish as RVR where authorized. Otherwise, establish as a statute mile (SM) value. Meter (M) values are for locations outside the United States only.

3.3.2 a. Step 1. Find the visibility (RVR or SM) appropriate to the HATh and ALS from the applicable table(s). When more than one table applies, use the highest value.

3.3.2 a. (1) Table 3-5a specifies standard civil and military straight-in minimums except for CAT A and B NPA, Category II/III ILS, Special Authorization (SA) Category I/II ILS, and helicopter approaches.

3.3.2 a. (2) Use table 3-6 exclusively for CAT A straight-in NPA approaches. Use table 3-7 exclusively for CAT B straight-in NPA approaches.

3.3.2 a. (3) Use table 3-8 for CAT C/D/E straight-in NPA approaches after determining the visibility minimums prescribed by table 3-5a.

Table 3-5a. Authorized Straight-in RVR/Visibility, (except CAT A and B NPA, CAT II/III ILS, SA CAT I/II ILS and helicopters).

HATH Range			FALS			IALS			BALS			NALS		
			RVR	SM	M	RVR	SM	M	RVR	SM	M	RVR	SM	M
		200	1800 ^{1,2} , 2400	1/2	550 ^{1,2} , 750	4000	3/4	1200	4000	3/4	1200	4000	3/4	1200
201	-	210	1800 ¹ , 2400	1/2	550 ¹ , 750	4000	3/4	1200	4000	3/4	1200	4000	3/4	1200
211	-	220	1800 ¹ , 2400	1/2	550 ¹ , 750	4000	3/4	1200	4000	3/4	1200	4000	3/4	1200
221	-	230	1800 ¹ , 2400	1/2	550 ¹ , 750	4000	3/4	1200	4000	3/4	1200	4000	3/4	1200
231	-	240	1800 ¹ , 2400	1/2	550 ¹ , 750	4000	3/4	1200	4000	3/4	1200	4000	3/4	1200
241	-	250	1800 ¹ , 2400	1/2	550 ¹ , 750	4000	3/4	1200	4000	3/4	1200	4000	3/4	1300
251	-	260	1800 ¹ , 2400	1/2	600 ¹ , 750	4000	3/4	1200	4000	3/4	1200	4000	3/4	1300
261	-	280	2000 ¹ , 2400	1/2	600 ¹ , 750	4000	3/4	1200	4000	3/4	1200	4500	7/8	1300
281	-	300	2200 ¹ , 2400	1/2	650 ¹ , 750	4000	3/4	1200	4000	3/4	1200	4500	7/8	1400
301	-	320	2400	1/2	700 ¹ , 750	4000	3/4	1200	4000	3/4	1200	4500	7/8	1400
321	-	340	2600	1/2	800	4000	3/4	1200	4500	7/8	1300	5000	1	1500
341	-	360	3000	5/8	900	4000	3/4	1200	4500	7/8	1400	5500	1	1600
361	-	380	3500	5/8	1000	4000	3/4	1300	5000	1	1500	5500	1	1700
381	-	400	3500	5/8	1100	4500	7/8	1400	5000	1	1600	6000	1 1/8	1800
401	-	420	4000	3/4	1200	5000	1	1500	5500	1	1700	6000	1 1/8	1900
421	-	440	4000	3/4	1300	5000	1	1600	6000	1 1/8	1800		1 1/4	2000
441	-	460	4500	7/8	1400	5500	1	1700	6000	1 1/8	1900		1 3/8	2100
461	-	480	5000	1	1500	6000	1 1/8	1800		1 1/4	2000		1 3/8	2200
481	-	500	5000	1	1500	6000	1 1/8	1800		1 1/4	2100		1 3/8	2300
501	-	520	5500	1	1600		1 1/4	1900		1 3/8	2100		1 3/8	2400
521	-	540	5500	1	1700		1 1/4	2000		1 3/8	2200		1 1/2	2400
541	-	560	6000	1 1/8	1800		1 3/8	2100		1 3/8	2300		1 5/8	2500
561	-	580		1 1/4	1900		1 3/8	2200		1 1/2	2400		1 5/8	2600
581	-	600		1 1/4	2000		1 3/8	2300		1 5/8	2500		1 3/4	2700
601	-	620		1 3/8	2100		1 1/2	2400		1 5/8	2600		1 3/4	2800
621	-	640		1 3/8	2200		1 1/2	2500		1 3/4	2700		1 3/4	2900
641	-	660		1 3/8	2300		1 5/8	2600		1 3/4	2800		1 7/8	3000
661	-	680		1 1/2	2400		1 3/4	2700		1 3/4	2900		1 7/8	3100
681	-	700		1 1/2	2500		1 3/4	2800		1 7/8	3000		2	3200
701	-	720		1 5/8	2600		1 3/4	2900		1 7/8	3100		2	3300
721	-	740		1 5/8	2700		1 3/4	3000		2	3200		2	3400
741	-	760		1 3/4	2700		1 7/8	3000		2	3300		2	3500
761	-	800		1 3/4	2900		2	3200		2	3400		2 1/2	3600
801	-	850		1 7/8	3100		2	3400		2 1/2	3600		2 1/2	3800
851	-	900		2	3300		2 1/2	3600		2 1/2	3800		2 1/2	4000
901	-	950		2	3600		2 1/2	3900		2 1/2	4100		2 1/2	4300
951	-	1000		2 1/2	3800		2 1/2	4100		2 1/2	4300		3	4500
1001	-	1100		2 1/2	4100		2 1/2	4400		3	4600		3	4900
1101	-	1200		3	4600		3	4900		3	5000		3	5000
1201	-	Above		3	5000		3	5000		3	5000		3	5000

1. Category I PA with TDZ/CL lights.

2. Category I PA without TDZ/CL lights when authorized by Order 8400.13. See Order 8260.19 for charting/annotations.

**Table 3-5b. U.S. Military Standard Minimums
PAR with HATh < 200 ft (all CATs)**

ALS TDZ/CL			ALS/SSALR/SALS/SSALR			MALSR/MALS/ODALS			NO LIGHTS		
RVR	SM	M	RVR	SM	M	RVR	SM	M	RVR	SM	M
1200	-	350	1600	1/4	500	2400	1/2	750	2400	½	750

Table 3-6. CAT A Straight-in NPA, Authorized RVR/Visibility

HATH/HAA	FALS			IALS			BALS			NALS		
	RVR	SM	M	RVR	SM	M	RVR	SM	M	RVR	SM	M
250-880	2400 ¹	1/2 ¹	750 ¹	4000	3/4	1200	4000	3/4	1200	5500	1	1600
881 and above	4000	3/4	1200	5500	1	1600	5500	1	1600	6000	1 1/4	2000

1. RVR 4000, 3/4 SM, 1200m (NDB).

Table 3-7. CAT B Straight-in NPA, Authorized RVR/Visibility.

HATH/HAA	FALS			IALS			BALS			NALS		
	RVR	SM	M	RVR	SM	M	RVR	SM	M	RVR	SM	M
250-740	2400 ¹	1/2 ¹	800 ¹	4000 ²	3/4	1200	4000	3/4	1200	5500	1	1600
741-950	4000	3/4	1200	5500	1	1600	5500	1	1600	6000	1 1/4	2000
951-above	5500	1	1600	6000	1 1/4	2000	6000	1 1/4	2000		1 1/2	2400

1. RVR 4000, 3/4 SM, 1200m (NDB).

Table 3-8. Minimum Straight-in RVR/Visibility NPA Procedures CAT C/D/E

Procedure Design :					
- Final Course-RWY C/L offset: < = 5° - Final Approach segment > = 3 NM - With PFAF procedure - **PFAF to RWY TH < = 8 NM (**Timed approaches ONLY)					ALL OTHERS
RVR	SM	M	RVR	SM	M
2400	1/2	750	4000	3/4	1200

3.3.2 b. Step 2. Determine visibility based on MAP/DA to LTP distance [see figure 3-2]:

3.3.2 b. (1) When the NPA MAP is located at or after the LTP, proceed to Step 3. Otherwise, determine the distance from the NPA MAP (plotted position) or PA/APV DA to the LTP. When authorized by paragraph 3.1.3b, subtract the ALS length (2400 ft for FALS, 1400 ft for IALS, and 700 ft for BALS). When this distance is less than or equal to the visibility from Step 1, use the Step 1 value. When greater than the visibility from Step 1, use the next higher visibility value (RVR or SM) from the applicable table or the next higher whole SM when the distance exceeds 3 SM.

Figure 3-2. MAP/DA to LTP distance Straight-in Aligned

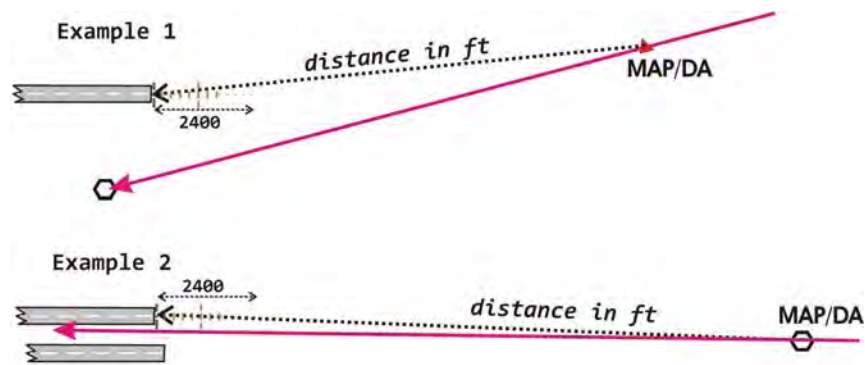

3.3.2 c. Step 3. Determine visibility based on evaluation of the visual portion of the final approach segment. Apply the Standard visual area to runways to which an aircraft is authorized to circle (either in association with a SI procedure or a Circling only approach). Apply the Straight-In area to runways with approach procedures aligned with the runway centerline (less than or equal to $\pm 0.03^\circ$). Apply the Offset visual area to evaluate the visual portion of a straight-in approach that is not aligned with the runway centerline (more than $\pm 0.03^\circ$). These evaluations determine if night operations must be prohibited due to unlit obstacles or if visibility minimums must be restricted.

Note: Assess the appropriate visual area separately for each line of minima on the same approach plate.

3.3.2 c. (1) Visual Area Types.

3.3.2 c. (1) (a) Standard [see figure 3-3a].

- Alignment. Align with the runway centerline extended (RCL).
- Length. The area begins 200 ft from LTP at LTP elevation and extends 10,000 ft out RCL
- Width. The beginning width is ± 200 ft either side of RCL. The sides splay outward relative to runway centerline. Calculate the half-width of the area at any distance "d" from its origin using formula 3-3a:

Formula 3-3a. Standard Visual Area 1/2 width

$$\frac{1}{2}W = (0.15 \times d) + 200$$

where $\frac{1}{2}W$ = perpendicular distance (feet) RCL to area edge
 d = distance (feet) from origin measured along RCL

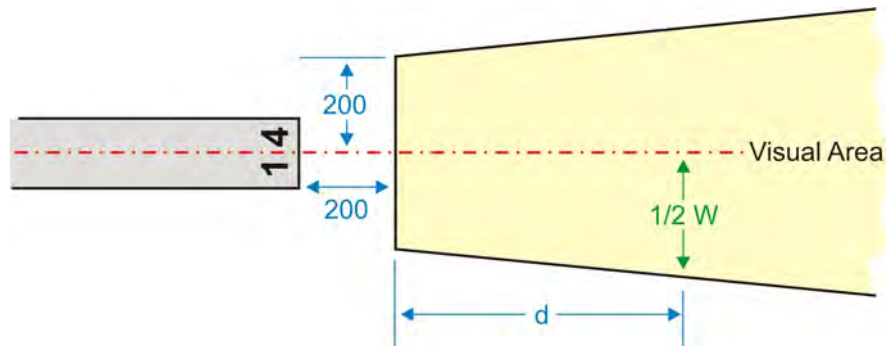
Figure 3-3a. Standard Visual Area

3.3.2 c. (1) (b) Straight-in. (Procedure need not meet straight-in descent criteria) [see figure 3-3b].

- Alignment. Align with the RCL extended.
- Length. The area begins 200 ft from LTP at LTP elevation and extends to the calculated DA point for each PA or APV procedure and to the VDP location (even if one is not published for NPA procedures) [see Vol., para 253].
- Width. The beginning width is ± 200 ft for runways limited to CAT A/B minimums and ± 400 ft for all other runways. The sides splay outward relative to RCL. Calculate the half-width of the area at any distance “d” from its origin using formula 3-3b:

Note: When multiple NPA minimums are published on the same chart (i.e., dual minimums or applicable RNAV procedures) use the lowest MDA to determine VDP location and to determine the length of the visual area. For PA/APV approaches, calculate the DA point based on the primary altimeter source.

Formula 3-3b. Straight-in Visual Area 1/2 width

$$\frac{1}{2}W = (0.138 \times d) + k$$

where $\frac{1}{2}W$ = perpendicular distance (feet) RCL to area edge
 d = distance (feet) from origin measured along RCL
 k = 200 for Cat A/B, 400 for Cat C/D/E

Figure 3-3b. Straight-in Visual Area

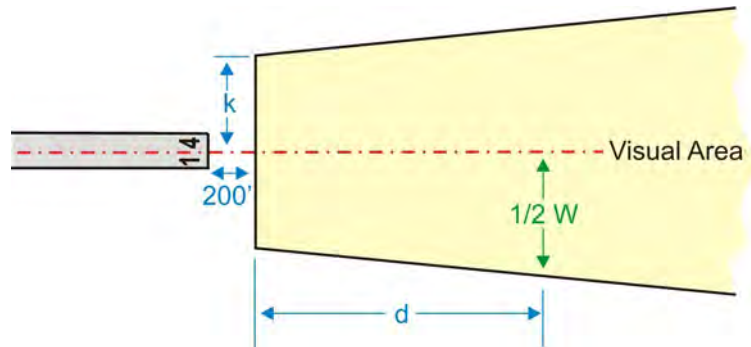

3.3.2 c. (1) (c) Offset [see figure 3-3c]: When the final course does not coincide with the RCL ($\pm 0.03^\circ$), modify the straight-in visual area as follows:

- Step A. Draw the straight-in area aligned with the RCL as previously described.
- Step B. Extend a line perpendicular to the final approach course (FAC) from the DA point or VDP (even if one is not published) to the point it crosses the RCL.
- Step C. Extend a line from this point perpendicular to the RCL to the outer edge of the straight-in area, noting the length (L).
- Step D. Extend a line in the opposite direction of the line in Step B from the DA/VDP perpendicular to the FAC for distance (L).
- Step E. Connect the end of the line constructed in Step D to the end of the inner edge of the area origin line 200 ft from LTP.

Figure 3-3c. Offset Visual Area

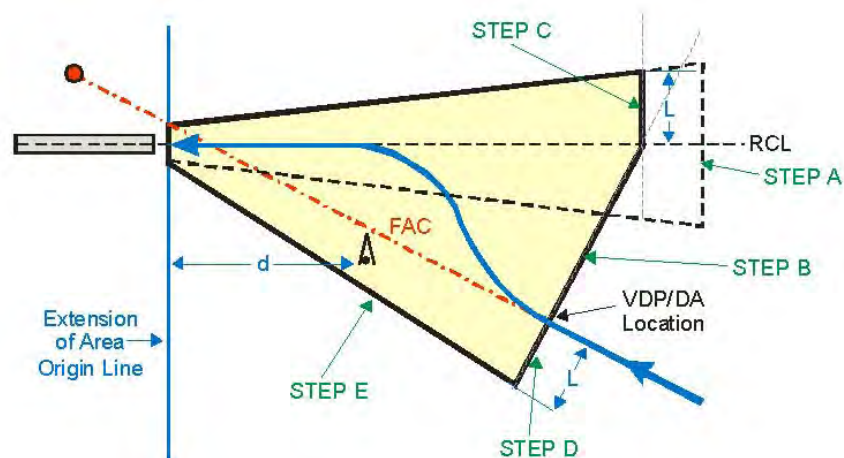

3.3.2 c. (2) Obstacle Clearance. When evaluating a straight-in or offset visual area, apply both a 34:1 and a 20:1 surface. When evaluating the standard visual area, apply a 20:1 surface only. Calculate surface height above LTP elevation at any distance “d” from an extension of the area origin line using formula 3-3c:

Formula 3-3c. Visual Area OIS Height

$$20:1 \text{ Surface Height} = \frac{d}{20}$$

$$34:1 \text{ Surface Height} = \frac{d}{34}$$

where d = distance (feet) from origin line (extended) measured along RCL

3.3.2 c. (2) (a) 34:1 OIS. If penetrated, limit visibility to no lower than 4000 RVR or 3/4 SM.

3.3.2 c. (2) (b) 20:1 OIS. If penetrated, take the following action:

- Lighted Obstacles: Do not publish a VDP and limit visibility to no lower than 5000 RVR or 1 SM.
- Unlighted Obstacles: Do not publish a VDP, limit visibility to no lower than 5000 RVR or 1 SM, and annotate the chart denying the approach or applicable minimums at night.
 - A Visual Glide Slope Indicator (VGSI) may be used in lieu of obstruction lighting with Flight Standards or Military authority approval. USAF not applicable.

3.3.2 d. Step 4. Establish the SI visibility as the highest value determined from Steps 1-3.

3.3.2 d. (1) Visibility greater than 3 SM. Where the HATh is 1000 ft or higher, 3 SM visibility may be established with Flight Standards approval when the procedure is annotated “Fly Visual to Airport.”

Note 1: “Fly Visual to Airport” provides relief from visual reference requirements specified in Part 91.175, and related rules such as 121.651, 135.225, and 125.381. This option will only be approved where deemed safe and operationally beneficial.

Note 2: Not applicable to procedures developed under Order 8260.49, Simultaneous Offset Instrument Approaches (SOIA), Order 7110.98 Simultaneous Converging Instrument Approaches, or Order 7110.110 Dependent Converging Instrument Approaches (DCIA) With Converging Runway Display Aid (CRDA).

Policy
Memo
07/30/08

3.3.2 e. When authorized approach light credit, determine the applicability of the U.S Terminal Procedures Publication (TPP) “Inoperative Components or Visual Aids” (INOP Components) table. This step is not applicable to the USAF.

3.3.2 e. (1) Determine the visibility required without approach lights.

3.3.2 e. (1) (a) Follow Step 1, except use the visibility from the NALS column.

Figure 3-4. Example U.S. TPP Inoperative Components or Visual Aids Table

INOPERATIVE COMPONENTS OR VISUAL AIDS TABLE

Landing minimums published on Instrument approach procedure charts are based upon full operation of all components and visual aids associated with the particular Instrument approach chart being used. Higher minimums are required with Inoperative components or visual aids as indicated below. If more than one component is Inoperative, each minimum is raised to the highest minimum required by any single component that is Inoperative. ILS glide slope Inoperative minimums are published on the Instrument approach charts as localizer minimums. This table may be amended by notes on the approach chart. Such notes apply only to the particular approach category(ies) as stated. See legend page for description of components indicated below.

(1) ILS, MLS, PAR and RNAV (LPV line of minima)

Inoperative Component or Aid	Approach Category	Increase Visibility
ALSF 1 & 2, MALSR, & SSALR	ABCD	¼ mile

(2) ILS with visibility minimum of 1,800 RVR

ALSF 1 & 2, MALSR, & SSALR TDZL RCLS RVR	ABCD	To 4000 RVR
	ABCD	To 2400 RVR*
	ABCD	To ½ mile

*1800 RVR authorized with the use of FD or AP or HUD to DA.

(3) VOR, VOR/DME, TACAN, LOC, LOC/DME, LDA, LDA/DME, SDF, SDF/DME, GPS, ASR and RNAV (LNAV/VNAV and LNAV line of minima)

Inoperative Visual Aid	Approach Category	Increase Visibility
ALSF 1 & 2, MALSR, & SSALR	ABCD	½ mile
SSALS, MALS, & ODALS	ABC	¼ mile

(4) NDB

ALSF 1 & 2, MALSR, & SSALR MALS, SSALS, ODALS	C	½ mile
	ABD	¼ mile
	ABC	¼ mile

3.3.2 e. (1) (b) Follow Step 2, except do not subtract the ALS length.

- 3.3.2 e. (2) Add the visibility increase from the INOP Components table to the SI visibility determined in Step 4. When the result is not equal to or greater than the visibility without approach lights [paragraph 3.3.2e (1)], annotate the chart in accordance with Order 8260.19, paragraph 8-54m.

3.3.3 Establishing Circling Visibility Minimums. Establish as a statute mile (SM) value. Meter (M) values are for locations outside the United States only.

- 3.3.3 a. Step 1.** Determine the minimum HAA based on CAT from table 3-9, and then find the visibility appropriate to the HAA and CAT from table 3-10.

Table 3-9. Minimum Authorized HAA

CAT	A	B	C	D	E
HAA	350	450		550	

Table 3-10. Authorized Circling Visibility Minimums

CAT →	A		B		C		D		E	
HAA ↓	SM	M	SM	M	SM	M	SM	M	SM	M
350 - 449	1	1600								
450 - 549	1	1600	1	1600	1 1/2	2400				
550 - 600	1	1600	1	1600	1 1/2	2400	2	3200	2	3200
601 - 670	1	1600	1	1600	1 3/4	2800	2	3200	2 1/4	3600
671 - 740	1	1600	1	1600	2	3200	2 1/4	3600	2 1/2	4000
741 - 810	1	1600	1	1600	2 1/4	3600	2 1/2	4000	2 3/4	4400
811 - 880	1 1/4	2000	1 1/4	2000	2 1/2	4000	2 3/4	4400	3	4800
881 - 950	1 1/4	2000	1 1/4	2000	2 3/4	4400	3	4800	3	4800
951 and above	1 1/4	2000	1 1/2	2400	3	4800	3	4800	3	4800

- 3.3.3 b. Step 2.** Determine visibility based on MAP to nearest landing surface distance [see figure 3-5] (not applicable to circling minimums published in conjunction with SI procedure).

- 3.3.3 b. (1) For procedures meeting straight-in alignment requirements not authorized straight-in minimums, apply paragraph 3.3.2b.

- 3.3.3 b. (2) For “Circling-only” procedures not meeting straight-in alignment requirements, when the MAP is located at or after the nearest landing surface, proceed to Step 3. Otherwise, determine the distance from the MAP (plotted position) to the nearest landing surface. When this distance is less than or equal to the visibility from Step 1, use the Step 1 value. When greater than the visibility from Step 1, use the next higher table value (next higher whole SM when the distance exceeds 3 SM).

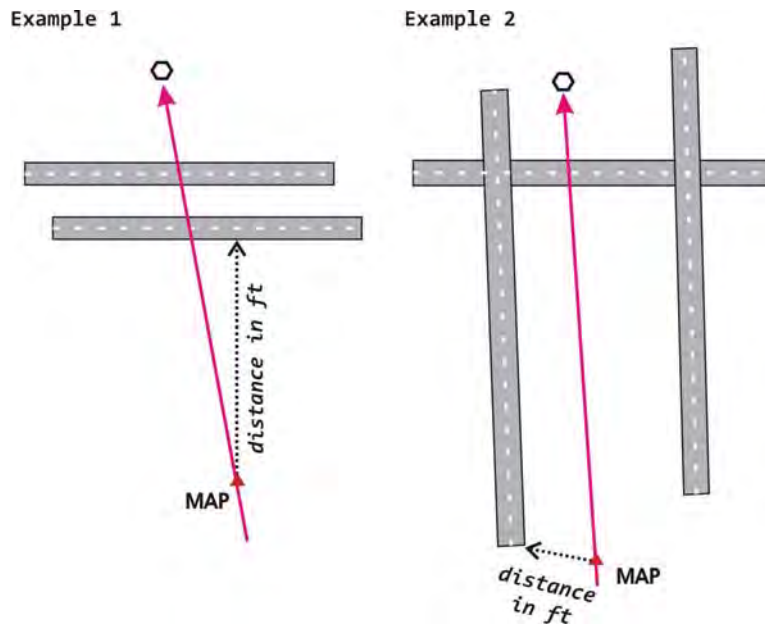
Figure 3-5. MAP to Nearest Landing Surface, Circling Aligned

3.3.3 c. Step 3. Determine visibility based on evaluation of the visual portion of the final approach segment [see paragraph 3.3.2c].

3.3.3 d. Step 4. For circling minimums published in conjunction with SI procedure, compare circling visibility to the established SI visibility.

3.3.3 d. (1) The circling visibility may not be lower than the no-light visibility of the SI visibility of the highest NPA line.

Note: For dual minimums, the circling visibility is compared to the corresponding SI visibility set (e.g., “UKENE FIX MINIMUMS” circling visibility compared to “UKENE FIX MINIMUMS” straight-in visibility).

3.3.3 e. Step 5. Establish circling visibility as the highest value determined from Steps 1-4 (as applicable).

3.3.3 e. (1) Visibility greater than 3 SM. Where the HAA is 1000 ft or higher, 3 SM visibility may be established with Flight Standards approval when the procedure is annotated “Fly Visual to Airport.”

Note 1: “Fly Visual to Airport” provides relief from visual reference requirements specified in Part 91.175, and related rules such as 121.651, 135.225, and 125.381. This option will only be approved where deemed safe and operationally beneficial.

Policy
Memo
07/30/08

Chapter 3. Takeoff and Landing Minimums

Section 4. Alternate Minimums

3.4. Civil Alternate Minimums [see 14 CFR Part 91.169] (Military – Refer to applicable Service Directives).

3.4.1 Authorization. To qualify the airport must have local weather disseminated via a “Service A” reporting network. Do not authorize alternate minimums when the facility providing final approach guidance is a CAT 3 monitored facility [see Order 8260.19, paragraph 2-13].

3.4.2 Establishing Alternate Minimums. If a procedure has a stepdown fix predicated on a CAT 3 monitored facility, base alternate minimums on the minimums without the fix.

3.4.2 a. Determine the need to establish alternate minimums by comparing the ceiling and/or visibility associated with the no-light minimums (local altimeter) for each approach category with the standard ceiling and visibility.

3.4.2 a. (1) When both the ceiling and visibility of the applicable no-light minimums are less than or equal to the standard specified in table 3-11, alternate minimums are not published.

3.4.2 a. (2) When either the ceiling or visibility from the applicable no-light minimums is greater than the standard, establish alternate minimums as the higher of the standard or the no-light value.

Note: Ceiling values are based on the DA/MDA minus airport elevation, rounded to the next higher 100-ft increment (e.g., 601 through 699 round to 700).

3.4.2 b. When required, alternate minimums are based on the NPA line with the highest ceiling or visibility on the same chart. For procedures without an NPA line, alternate minimums are based on the PA/APV line with the highest ceiling or visibility on the same chart.

3.4.2 c. Specify PA and NPA alternate minimums separately when both lines are published on the same chart.

Table 3-11. Standard Alternate Minimums

Approach Type	Ceiling	Visibility
NPA or APV	800	2
PA	600	2
Example (NPA or APV)		
Highest no-light Ceiling/Visibility	Alternate Minimums	
CAT A/B = 700 - 1	Not Published (Both Ceiling/Vis \leq Standard)	
CAT C = 800 - 2 1/4	800 - 2 1/4	
CAT D = 900 - 2 1/2	900 - 2 1/2	

**Chapter 3. Takeoff and Landing Minimums.
Section Five. Takeoff Minimums.**

3.5 Civil Standard Takeoff Minimums.

Title 14 CFR Part 91.175 (f) defines civil takeoff minimums as shown in table 3-12. A ceiling value may also be required to see and avoid an obstacle. In this case, the published procedure must identify the location of the obstacle(s) that must be avoided. See Order 8260.46, Departure Procedure (DP) Program, or appropriate Military directives for guidance on how and when other than standard takeoff minimums and/or obstacles are defined.

Table 3-12. Standard Civil Takeoff Minimums

Aircraft type	Visibility (SM)
Fixed wing w/ ≤ 2 engines	1
Fixed wing w/ > 2 engines	1/2
Helicopters 1/2	

Chapter 3. Takeoff and Landing Minimums. Section Four. Alternate Minimums.

- 3.4. Establishing Alternate Minimums (Other than Standard).** Establish alternate minimums (other than standard) for each applicable aircraft category whenever the ceiling and/or visibility of the *highest no-light minimums (category specific) exceed the standard specified in *table 3-12*.

Note: * Highest set when more than one set (e.g. dual minimums) published (remote altimeter not applicable).

ILS and LOC alternate minimums are specified separately. Alternate minimums for RNAV procedures are based on the no-light minimums of the highest NPA line when published. Otherwise base RNAV alternate minimums on no-light minimums of the highest APV line.

Published alternate minimums may be no lower than the applicable circling ceiling and/or visibility. *See Order 8260.19 and appropriate DoD directives for additional guidance.*

When only the ceiling or visibility of the highest minimums exceeds the *table 3-12* standard, use the higher values. *See table 3-12 example.*

Table 3-12. Standard Alternate Minimums.		
Approach Type	Ceiling	Visibility
NPA or APV	800	2
PA 600		2
Example (PA)		
Highest Ceiling/Visibility	Alternate Minimums	
CAT A/B = 700 – 1 1/4	Not Published (Ceiling/Vis < Standard)	
CAT C = 700 – 2 1/4	800 – 2 1/4	
CAT D = 900 – 2 1/2	900 – 2 1/2	

Chapter 3. Takeoff and Landing Minimums. Section Five. Takeoff Minimums.

3.5 Standard Takeoff Minimums.

Title 14 CFR Part 91.175 (f) civil takeoff minimums relate to the number of engines on the aircraft as shown in *table 3-13*. However, a ceiling value may also be required to see and avoid an obstacle. In this case, the published procedure must identify the location of the obstacle(s) that must be avoided. See Order 8260.46, *Departure Procedure (DP) Program*, or appropriate DoD directives for guidance on how and when other than standard takeoff minimums and/or obstacles are defined. Takeoff minimums for DoD operations must be as stated in the appropriate service directives.

Number of Engines	Visibility (SM)
1 or 2	1
3 or more	1/2

CHAPTER 4. ON-AIRPORT VOR (NO FAF)

400 GENERAL. This chapter is divided into two sections; one for low altitude procedures and one for high altitude teardrop penetration procedures. These criteria apply to procedures based on a VOR facility located on an airport in which no final approach fix (FAF) is established. These procedures must incorporate a procedure or a penetration turn. An ON-AIRPORT facility is one which is located:

a. **For Straight-In Approach.** Within one mile of the nearest portion of the landing runway.

b. **For Circling Approach.** Within one mile of the nearest portion of the usable landing surface of the airport.

401.-409. RESERVED.

SECTION 1. LOW ALTITUDE PROCEDURES

410. FEEDER ROUTES. Criteria for feeder routes are contained in paragraph 220.

411. INITIAL APPROACH SEGMENT. The initial approach fix is received by overheading the navigation facility. The initial approach is a procedure turn (PT). The criteria for the PT areas are contained in paragraph 234.

412. INTERMEDIATE SEGMENT. This type of procedure has no intermediate segment. Upon completion of the PT, the aircraft is on final approach.

413. FINAL APPROACH SEGMENT. The final approach begins where the PT intersects the FAC.

a. **Alignment.** The alignment of the FAC with the runway centerline determines whether a straight-in or circling-only approach may be established.

(1) **Straight-In.** The angle of convergence of the FAC and the extended runway centerline shall not exceed 30°. The FAC should be aligned to intersect the extended runway centerline 3,000 feet outward from the runway threshold. When an operational advantage can be achieved, this point of intersection may be established at any point between the runway threshold and a point

5,200 feet outward from the runway threshold. Also, where an operational advantage can be achieved, a FAC which does not intersect the runway centerline or intersects it at a distance greater than 5,200 feet from the threshold may be established, provided that such course lies within 500 feet, laterally, of the extended runway centerline at a point 3,000 feet outward from the runway threshold. Straight-in category C, D, and E minimums are not authorized when the final approach course intersects the extended runway centerline at an angle greater than 15° and a distance less than 3,000 feet (see figure 38).

(2) **Circling Approach.** When the final approach course alignment does not meet the criteria for straight-in landing, only a circling approach shall be authorized, and the course alignment should be made to the center of the landing area. When an operational advantage can be achieved, the final approach course may be aligned to pass through any portion of the usable landing surface (see figure 39).

b. **Area.** Figure 40 illustrates the final approach primary and secondary areas. The primary area is longitudinally centered on the final approach course, and is 10 miles long. The primary area is 2 miles wide at the facility and expands uniformly to 6 miles at 10 miles from the facility. A secondary area is on each side of the primary area. It is zero miles wide at the facility and expands uniformly to 1.34 miles on each side of the primary area at 10 miles from the facility. When the 5-miles PT is used, only the inner 5 miles of the final approach area need be considered.

c. Obstacle Clearance.

(1) **Straight-In.** The minimum obstacle clearance in the primary area is 300 feet. In the secondary area, 300 feet of obstacle clearance shall be provided at the inner edge, tapering uniformly to zero feet at the outer edge. The minimum required obstacle clearance at any given point in the secondary area is found in paragraph 523b(3).

(2) **Circling Approach.** In addition to the minimum requirements specified in paragraph 413c(1), obstacle clearance in the circling area shall be as prescribed in chapter 2, section 6.

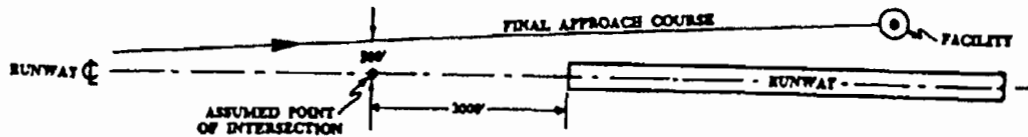
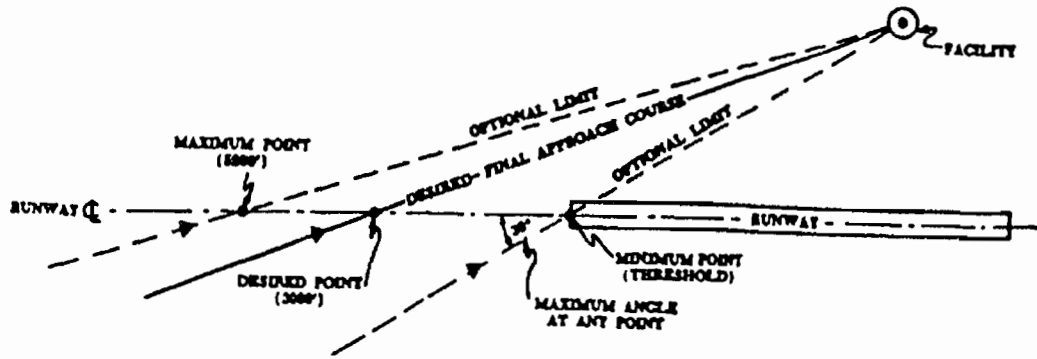

Figure 38. ALIGNMENT OPTIONS FOR FINAL APPROACH COURSE. On-Airport VOR, No FAF. Straight-In Approach Procedure. Par. 413a(1).

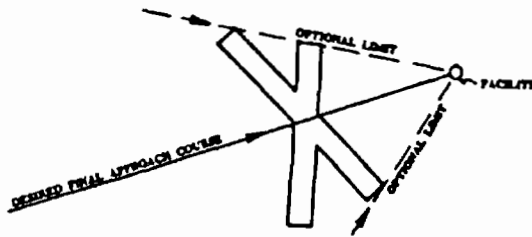

Figure 39. ALIGNMENT OPTIONS FOR FINAL APPROACH COURSE. On-Airport VOR. No FAF. Circling Approach Procedure. Par 413a(2).

d. PT Altitude (Descent Gradient). The PT completion altitude shall be within 1,500 feet of the MDA (1000 feet with a 5-mile PT), provided the distance from the facility to the point where the final approach course intersects the runway centerline (or the first usable portion of the landing area for "circling only" procedures) does not exceed 2 miles. When this distance exceeds 2 miles, the maximum difference between the PT completion altitude and the MDA shall be reduced at the rate of 25 feet for each one-tenth of a mile in excess of 2 miles (see figure 41).

NOTE: For those procedures in which the final approach does NOT intersect the extended runway centerline within 5200 feet of the runway threshold (see paragraph 413a(1)) the assumed point of intersection for computing the distance from the facility shall be 3000 feet from the runway threshold. See figure 38.

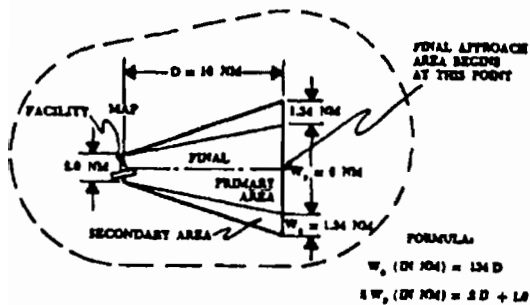

Figure 40. FINAL APPROACH PRIMARY AND SECONDARY AREAS. On-Airport VOR. No FAF. Par 413b.

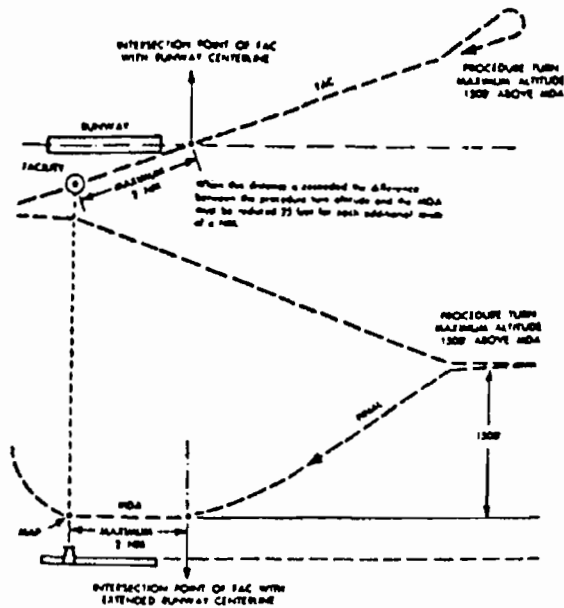

Figure 41. PT ALTITUDE. On-Airport VOR, No FAF. Par 413d.

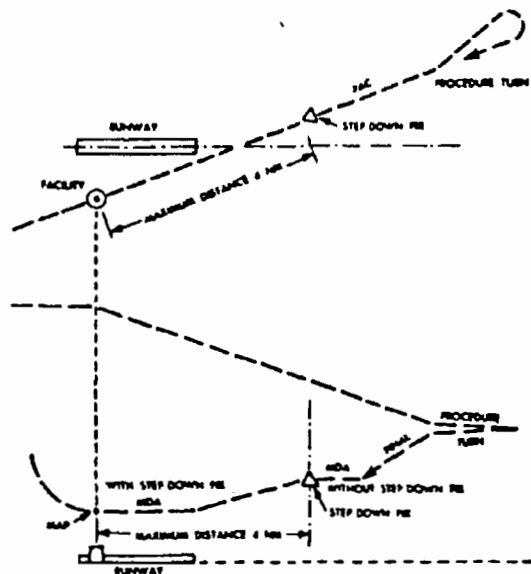

Figure 42. USE OF STEPDOWN FIX. On-Airport VOR. No FAF. Par 413e.

e. Use of a Stepdown Fix. Use of a stepdown fix (paragraph 288c) is permitted provided the distance from the facility to the stepdown fix does not exceed 4 miles. The descent gradient between PT completion altitude and stepdown fix altitude shall not exceed 150 ft/NM. The descent gradient will be computed based upon the difference in PT completion altitude minus

stepdown fix altitude, divided by the specified PT distance, minus the facility to stepdown fix distance. Obstacle clearance may be reduced to 250 feet from the stepdown fix to the MAP/FEP. See figure 42, paragraphs 251, 252, and 253.

f. MDA. Criteria for determining the MDA are contained in chapter 3.

414. MISSED APPROACH SEGMENT. Criteria for the missed approach segment are contained in chapter 2, section 7. The MAP is the facility (see figure 42). The missed approach surface shall commence over the facility at the required height. (see paragraph 274).

415-419. RESERVED.

SECTION 2. HIGH ALTITUDE TEARDROP PENETRATIONS

420. FEEDER ROUTES. Criteria for feeder routes are contained in paragraph 220.

421. INITIAL APPROACH SEGMENT (IAF). The IAF is received by overheading the navigation facility. The initial approach is a teardrop penetration turn. The criteria for the penetration turn are contained in paragraph 235.

422. INTERMEDIATE SEGMENT. This procedure has no intermediate segment. Upon completion of the penetration turn, the aircraft is on final approach.

423. FINAL APPROACH SEGMENT. An aircraft is considered to be on final approach upon completion of the penetration turn. However, the final approach segment begins on the FAC 10 miles from the facility. That portion of the penetration procedure prior to the 10-mile point is treated as the initial approach segment. See figure 43.

a. Alignment. Same as low altitude (paragraph 413a).

b. Area. Figure 43 illustrates the final approach primary and secondary areas. The primary area is longitudinally centered on the FAC and is 10 miles long. The primary area is 2 miles wide at the facility and expands uniformly to 8 miles at a point 10 miles from the facility. A secondary area is on each side of the primary area. It is zero miles wide at the facility, and expands uniformly to 2 miles each side of the primary area at a point 10 miles from the facility.

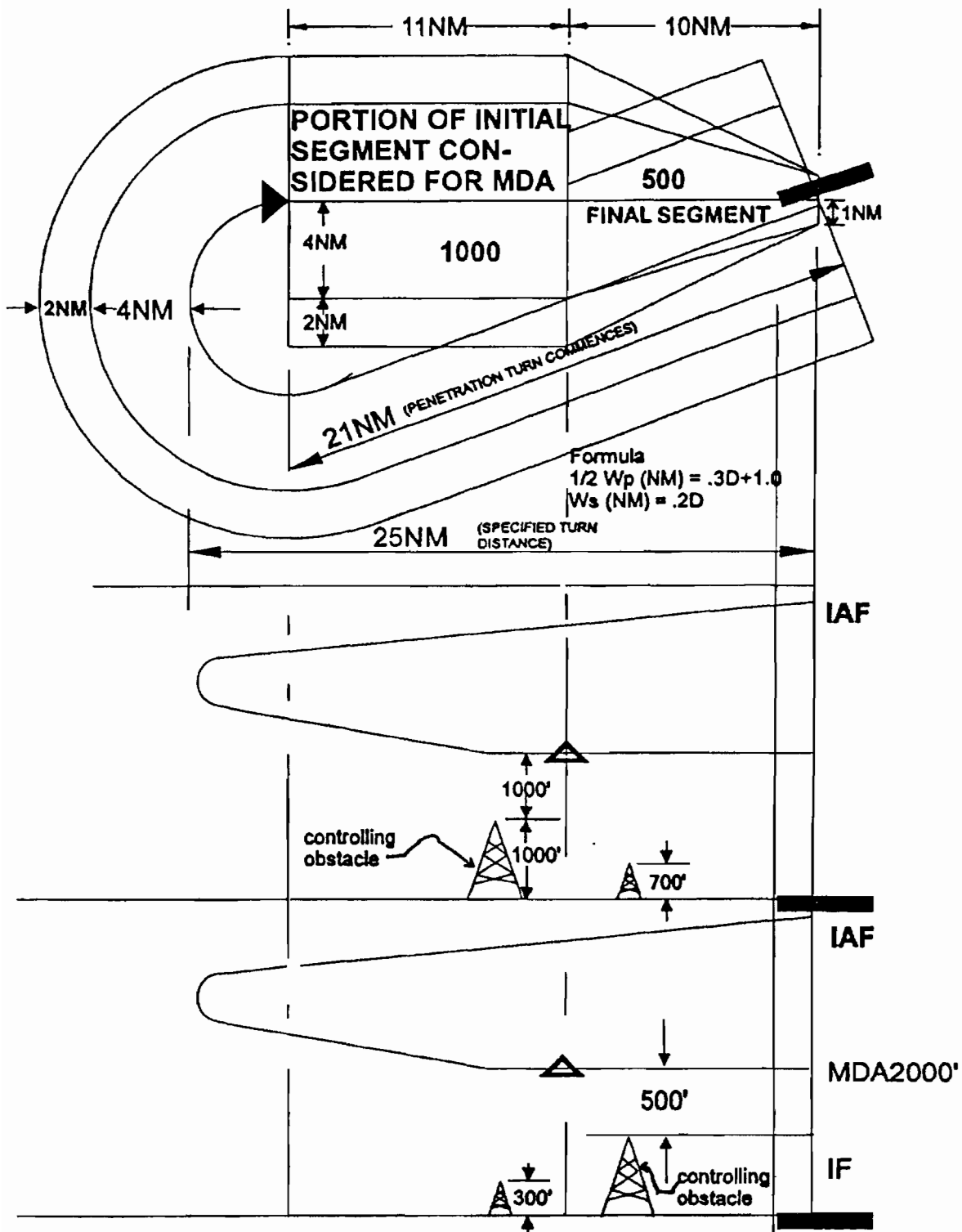

Figure 43. PENETRATION TURN. On-Airport VOR. No FAF. Par 423.

c. Obstacle Clearance.

(1) **Straight-In.** The minimum obstacle clearance in the primary area is 500 feet. In the secondary area, 500 feet of obstacle clearance shall be provided at the inner edge, tapering uniformly to zero feet at the outer edge. The minimum ROC at any given point in the secondary area is found in paragraph 232c.

(2) **Circling Approach.** In addition to the minimum requirements specified in paragraph 423c(1), obstacle clearance in the circling area shall be as prescribed in chapter 2, section 6.

d. Penetration Turn Altitude (*Descent Gradient*). The penetration turn completion altitude shall be at least 1,000 feet, but not more than 4,000 feet above the MDA on final approach.

e. Use of Stepdown Fix. The use of the stepdown fix is permitted provided the distance from the facility to the

stepdown fix does not exceed 10 miles (see paragraph 288c).

f. MDA. In addition to the normal obstacle clearance requirement of the final approach segment (see paragraph 423c), the MDA specified shall provide at least 1,000 feet of clearance over obstacles in the portion of the initial approach segment between the final approach segment and the point where the assumed penetration turn track intercepts the inbound course (see figure 43).

424. MISSED APPROACH SEGMENT. Criteria for the missed approach segment are contained in chapter 2, section 7. The MAP is the facility (see figure 43). The missed approach surface shall commence over the facility at the required height (see paragraph 274).

425.-499. RESERVED.

THIS PAGE INTENTIONALLY LEFT BLANK

CHAPTER 5. TACAN, VOR/DME, AND VOR WITH FAF

500. GENERAL. This chapter applies to approach procedures based on the elements of the VORTAC facility; i.e., VOR, VOR/DME, and TACAN, in which a final approach fix (FAF) is established. The chapter is divided into two sections; Section 1 for VOR procedures which do not use DME as the primary method for establishing fixes, and Section 2 for VOR/DME and TACAN procedures which use collocated, frequency paired DME as the sole method of establishing fixes. When both the VOR and TACAN azimuth elements of a VORTAC station will support it, a single procedure, identified as a VOR/DME or TACAN shall be published. Such a procedure may be flown using either a VOR/DME or TACAN airborne receiver and shall satisfy TACAN terminal area fix requirements. See Paragraph 286.d.

501. – 509. RESERVED.

Section 1. VOR with FAF

510. FEEDER ROUTES. Criteria for feeder routes are contained in Paragraph 220.

511. INITIAL APPROACH SEGMENT. Criteria for the initial approach segment are contained in Chapter 2, Section 3. See Figures 44 and 45.

512. INTERMEDIATE APPROACH SEGMENT. Criteria for the Intermediate approach segment are contained in Chapter 2, Section 4. See Figures 44 and 45.

513. FINAL APPROACH SEGMENT. The final approach may be made either "FROM" or "TOWARD" the facility. The final approach segment begins at the final approach fix and ends at the runway or missed approach point, whichever is encountered last.

a. Alignment. The alignment of the final approach course with the runway centerline determines whether a straight-in or circling-only approach may be established. The alignment criteria

differs depending on whether the facility is OFF or ON the airport. See definitions in Paragraph 400.

(1) Off-Airport Facility.

(a) Straight-In. The angle of convergence of the final approach course and the extended runway centerline shall not exceed 30 degrees. The final approach course should be aligned to intersect the runway centerline at the runway threshold. However, when an operational advantage can be achieved, the point of intersection may be established as much as 3000 feet outward from the runway threshold. See Figure 46.

(b) Circling Approach. When the final approach course alignment does not meet the criteria for a straight-in landing, only a circling approach shall be authorized, and the course alignment should be made to the center of the landing area. When an operational advantage can be achieved, the final approach course may be aligned to any portion of the usable landing surface. See Figure 47.

(2) On-Airport Facility.

(a) Straight-In. The angle of convergence of the final approach course and the extended runway centerline shall not exceed 30 degrees. The final approach course should be aligned to intersect the extended runway centerline 3000 feet outward from the runway threshold. When an operational advantage can be achieved, this point of intersection may be established at any point between the threshold and a point 5200 feet outward from the threshold. Also, where an operational advantage can be achieved a final approach course which does not intersect the runway centerline, or which intersects it at a distance greater than 5200 feet from the threshold, may be established, provided that such a course lies within 500 feet laterally of the extended runway centerline at a point 3000 feet outward from the runway threshold. See Figure 48.

(b) Circling Approach. When the final approach course alignment does not meet the crite-

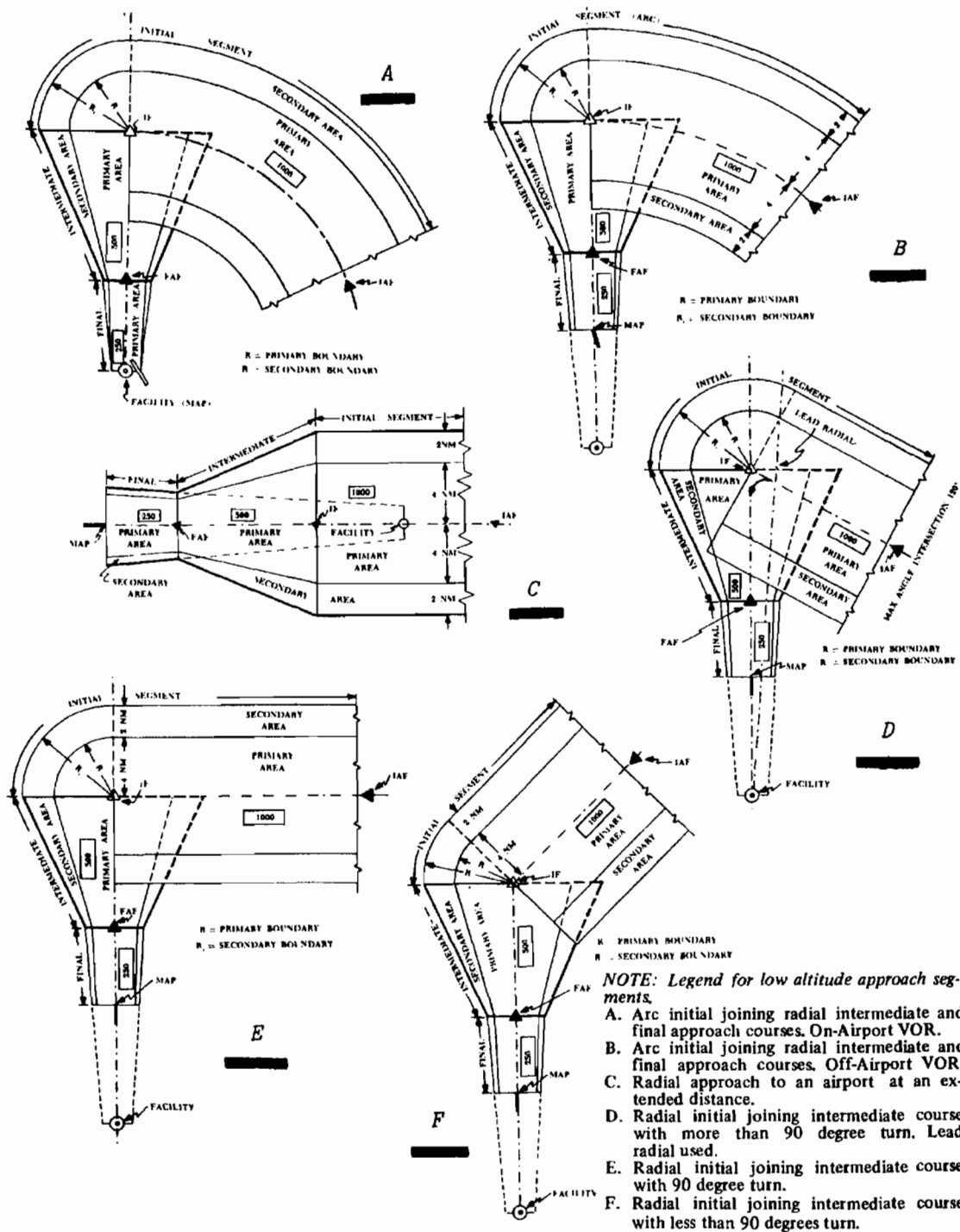

Figure 44. TYPICAL LOW ALTITUDE APPROACH SEGMENTS. VOR with FAF. Par 511 and 512.

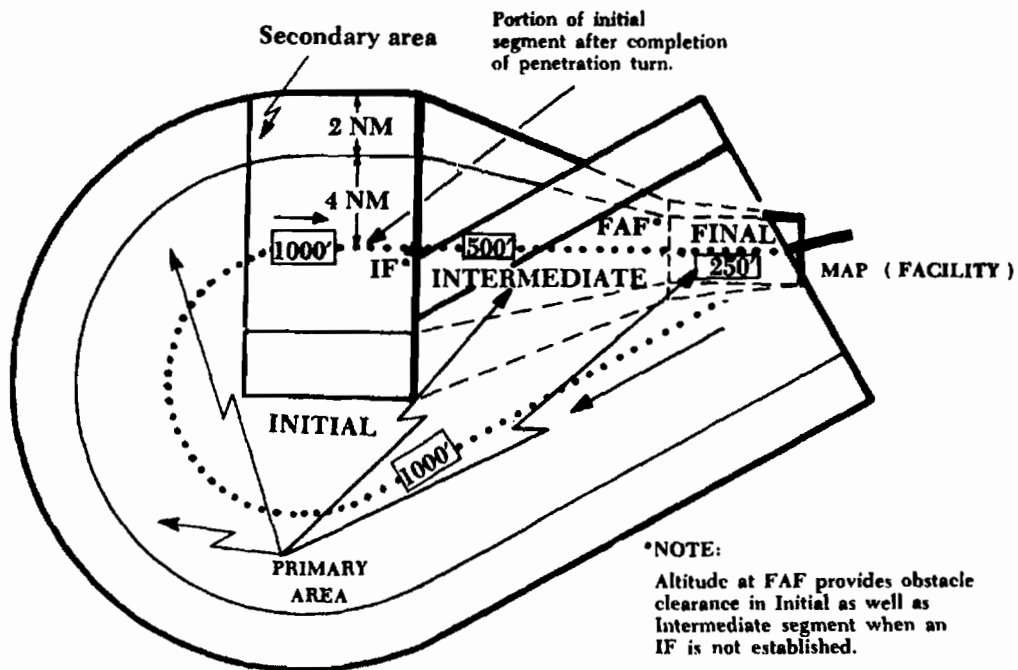

Figure 45. TYPICAL HIGH ALTITUDE SEGMENTS. VOR with FAF. Par 511 and 512.

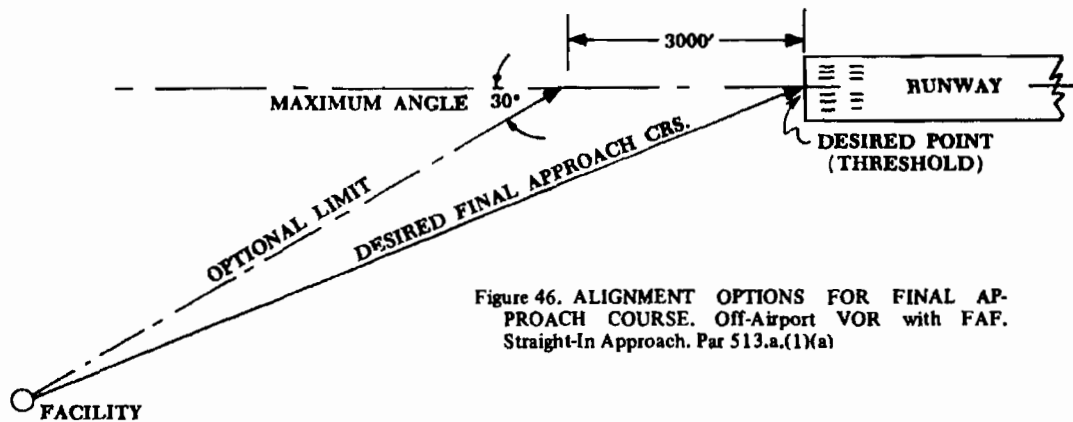

Figure 46. ALIGNMENT OPTIONS FOR FINAL APPROACH COURSE. Off-Airport VOR with FAF. Straight-In Approach. Par 513.a.(1)(a)

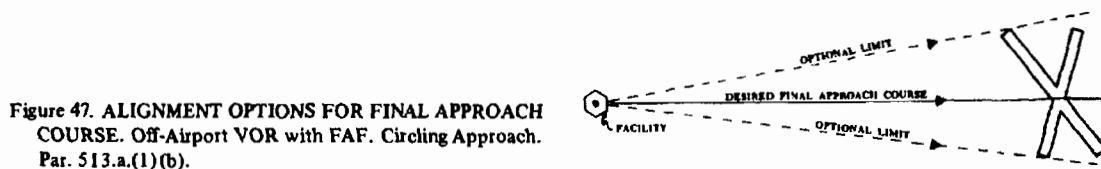

Figure 47. ALIGNMENT OPTIONS FOR FINAL APPROACH COURSE. Off-Airport VOR with FAF. Circling Approach. Par. 513.a.(1)(b).

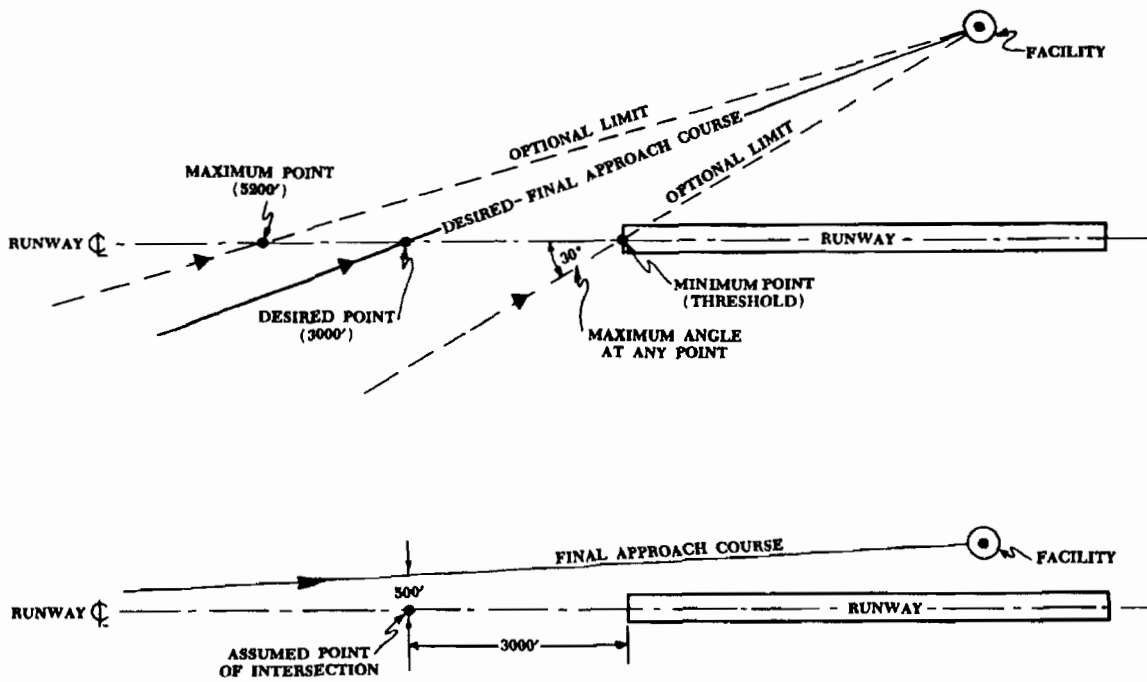

Figure 48. ALIGNMENT OPTIONS FOR FINAL APPROACH COURSE. On-Airport VOR with FAF. Straight-In Approach. Par 513.a.(2)(a)

ria for a straight-in landing, only a circling approach shall be authorized, and the course alignment should be made to the center of the landing area. When an operational advantage can be achieved, the final approach course may be aligned to any portion of the usable landing surface. See Figure 49.

b. Area. The area considered for obstacle clearance in the final approach segment starts at the final approach fix and ends at the runway or missed approach point, whichever is encountered last. It is a portion of a 30-mile long trapezoid (see Figure 50) which is made up of primary and secondary areas. The primary area is centered longitudinally on the final approach course. It is 2 miles wide at the facility, and expands uniformly to 5 miles wide at 30 miles from the facility. A secondary area is on each side of the primary area. It is zero miles wide at the facility and expands uniformly to 1 mile on each side of the primary area at 30 miles from the facility. Final approaches may be made to airports which are a maximum of 30 miles from the facility. See Figure 51. The OPTIMUM length of the final approach segment is 5 miles. The MAXIMUM length is 10 miles. The MINIMUM length of the final approach

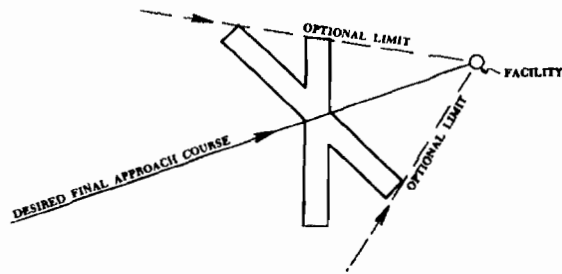

Figure 49. ALIGNMENT OPTIONS FOR FINAL APPROACH COURSE. On-Airport VOR with FAF. Circling Approach. Par 513.a.(2)(b).

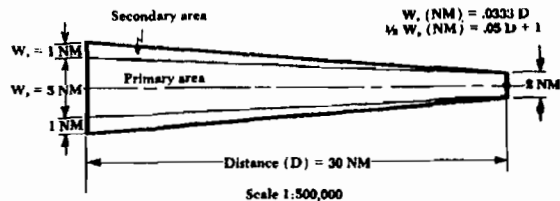

Figure 50. FINAL APPROACH TRAPEZOID. VOR with FAF. Par 513.b.

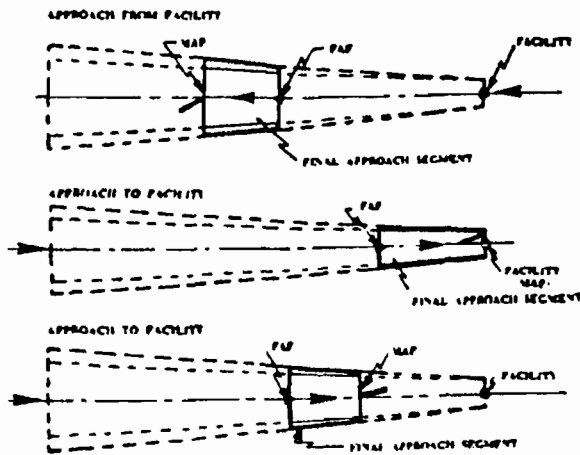

Figure 51. TYPICAL STRAIGHT-IN FINAL APPROACHES, VOR WITH FAF. Par 513b.

segment shall provide adequate distance for an aircraft to make the required descent, and to regain course alignment when a turn is required over the facility. Table 14 shall be used to determine the minimum length needed to regain the course.

c. Obstacle Clearance.

(1) **Straight-In Landing.** The minimum obstacle clearance in the primary area is 250 feet. In the secondary area, 250 feet of obstacle clearance shall be provided at the inner edge, tapering uniformly to zero feet at the outer edge. The minimum obstacle clearance at any given point in the secondary area is:

$$ROC = 250 \times \frac{Ws - d}{Ws}$$

Where Ws = Width of Secondary
 d = distance from inner edge

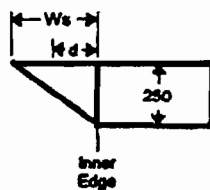

(2) **Circling Approach.** In addition to the minimum requirements specified in paragraph 513c(1), obstacle clearance in the circling area shall be as prescribed in chapter 2, section 6.

d. Descent Gradient. Paragraph 252 applies.

Table 14. MINIMUM LENGTH OF FINAL APPROACH SEGMENT-VOR (MILES).

Approach Category	Magnitude of Turn over Facility (Degrees)		
	10	20	30
A	1.0	1.5	2.0
B	1.5	2.0	2.5
C	2.0	2.5	3.0
D	2.5	3.0	3.5
E	3.0	3.5	4.0

NOTE: This table may be interpolated. If the minimum lengths specified in the table are not available, straight-in minimums are not authorized. See figure 51 for typical final approach areas.

e. **Use of Fixes.** Criteria for the use of radio fixes are contained in chapter 2, section 8. Where a procedure is based on a PT and an on-airport facility is the PT fix, the distance from the facility to the FAF shall not exceed 4 miles.

f. **MDA.** Criteria for determining the MDA are contained in chapter 3, section 2.

514. **MISSED APPROACH SEGMENT.** Criteria for the missed approach segment are contained in chapter 2, section 7. For VOR procedures, the MAP and surface shall be established as follows:

a. Off-Airport Facilities.

(1) **Straight-In.** The MAP is a point on the FAC which is NOT farther from the FAF than the runway threshold (see figure 52). The missed approach surface shall commence over the MAP at the required height (see paragraph 274).

(2) **Circling Approach.** The MAP is a point on the FAC which is NOT farther from the FAF than the first usable portion of the landing area. The missed approach surface shall commence over the MAP at the required height (see paragraph 274).

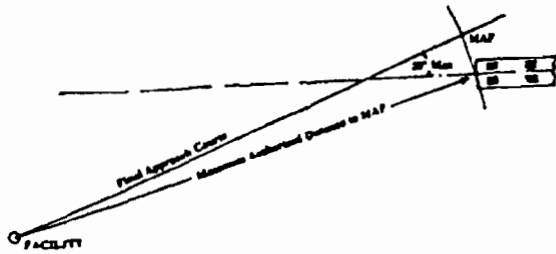

Figure 52. MAP.
Off-Airport VOR with FAF. Par 514a(1).

b. On-Airport Facilities. The MAP is a point on the FAC which is NOT farther from the FAF than the facility. The missed approach surface shall commence over the MAP at the required height (see paragraph 274).

515.-519. RESERVED.

SECTION 2. TACAN AND VOR/DME

520. FEEDER ROUTES. Criteria for feeder routes are contained in paragraph 220.

521. INITIAL SEGMENT. Due to the fixing capability of TACAN and VOR/DME a PT initial approach may not be required. Criteria for initial approach segments are contained in chapter 2, section 3.

522. INTERMEDIATE SEGMENT. Criteria for the intermediate segment are contained in chapter 2, section 4.

523. FINAL APPROACH SEGMENT. TACAN and VOR/DME final approaches may be based either on arcs or radials. The final approach begins at a FAF and ends at the MAP. The MAP is always marked with a fix.

a. Radial Final Approach. Criteria for the radial final approach are specified in paragraph 513.

b. Arc Final Approach. The final approach arc shall be a continuation of the intermediate arc. It shall be specified in NM and tenths thereof. Arcs closer than

7 miles (15 miles for high altitude procedures) and farther than 30 miles from the facility shall NOT be used for final approach. No turns are permitted over the FAF.

(1) Alignment. For straight-in approaches, the final approach arc shall pass through the runway threshold when the angle of convergence of the runway centerline and the tangent of the arc does not exceed 15°. When the angle exceeds 15°, the final approach arc shall be aligned to pass through the center of the airport and only circling minimums shall be authorized. See figure 53.

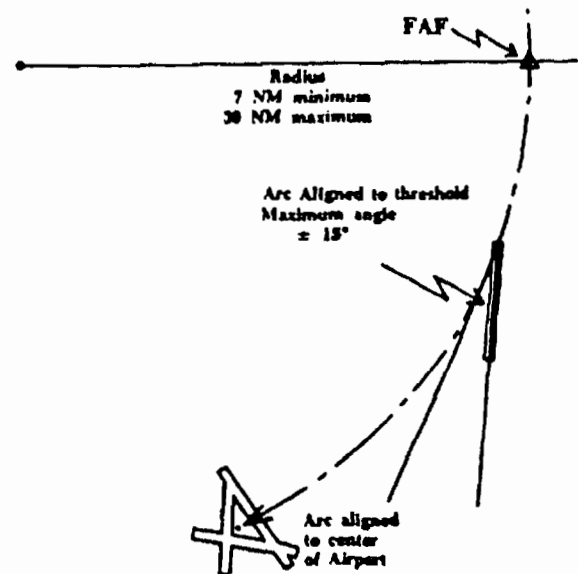

Figure 53. ARC FINAL APPROACH ALIGNMENT. Arc Aligned to Threshold. TACAN or VOR/DME. Par 523b(1).

(2) Area. The area considered for obstacle clearance in the arc final approach segment starts at the FAF and ends at the runway or MAP, whichever is encountered last. It should NOT be more than 5 miles long. It shall be divided into primary and secondary areas. The primary area is 8 miles wide, and extends 4 miles on either side of the arc. A secondary area is on each side of the primary area. The secondary areas are 2 miles wide on each side of the primary area (see figure 54).

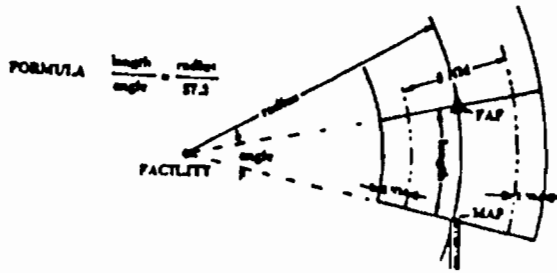
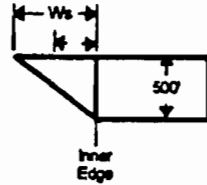

Figure 54. ARC FINAL APPROACH AREA. TACAN or VOR/DME. Par 523b(2)

(3) **Obstacle Clearance.** The minimum obstacle clearance in the primary area is 500 feet. In the secondary area, 500 feet of obstacle clearance shall be provided at the inner edge, tapering uniformly to zero feet at the outer edge.

$$\text{Secondary ROC} = 500 \times \frac{W_s - d}{W_s}$$

Where d = distance from inner edge
 W_s = Width of secondary area



(4) **Descent Gradient.** Criteria for descent gradients are specified in paragraph 252.

(5) **Use of Fixes.** Fixes along an arc are restricted to those formed by radials from the VORTAC facility which provides the DME signal. Criteria for such fixes are contained in chapter 2, section 8.

(6) **MDA.** Straight-in MDA's shall not be specified lower than circling for arc procedures. Criteria for determining the circling MDA are contained in chapter 3, section 2.

524. MISSED APPROACH SEGMENT. Criteria for the missed approach segment are contained in chapter 2, section 7. The MAP shall be a radial/DME fix. The missed approach surface shall commence over the fix and at the required height. Also see paragraph 514.

NOTE: The arc missed approach course may be a continuation of the final approach arc.

525.-599. RESERVED.

THIS PAGE INTENTIONALLY LEFT BLANK

CHAPTER 6. NDB PROCEDURES ON-AIRPORT FACILITY, NO FAF

600. GENERAL. This chapter is divided into two sections: one for low altitude procedures and one for high altitude teardrop penetration procedures. These criteria apply to NDB procedures based on a facility located on the airport in which no FAF is established. These procedures must incorporate a PT or a penetration turn. An on-airport facility is one which is located:

a. **For Straight-In Approach.** Within 1 mile of any portion of the landing runway.

b. **For Circling Approach.** Within 1 mile of any portion of the usable landing surface on the airport.

601.-609. RESERVED.

SECTION 1. LOW ALTITUDE PROCEDURES

610. FEEDER ROUTES. Criteria for feeder routes are contained in paragraph 220.

611. INITIAL APPROACH SEGMENT. The IAF is received by overheading the navigation facility. The initial approach is a PT. Criteria for the PT areas are contained in paragraph 234.

612. INTERMEDIATE SEGMENT. This type of procedure has no intermediate segment. Upon completion of the PT, the aircraft is on final approach.

613. FINAL APPROACH SEGMENT. The final approach begins where the PT intersects the FAC.

a. **Alignment.** The alignment of the FAC with the runway centerline determines whether a straight-in or circling-only approach may be established.

(1) **Straight-In.** The angle of convergence of the FAC and the extended runway centerline shall not exceed 30°. The FAC should be aligned to intersect the extended runway centerline 3,000 feet outward from the runway threshold. When an operational advantage can be achieved, this point of intersection may be established at any point between the runway threshold and a point 5,200 feet outward from the runway threshold. Also, where an operational advantage can be achieved, a FAC which does not intersect the runway centerline or intersects it at a distance greater than 5,200 feet from the threshold may be established, provided that such course lies within 500 feet, laterally, of the extended runway centerline at a point 3,000 feet outward from the runway threshold. Straight-in category C, D, and E minimums are not authorized when the final

approach course intersects the extended runway centerline at an angle greater than 15° and a distance less than 3,000 feet (see figure 55).

(2) **Circling Approach.** When the FAC alignment does not meet the criteria for straight-in landing, only a circling approach shall be authorized, and the course alignment should be made to the center of the landing area. When an operational advantage can be achieved, the FAC may be aligned to pass through any portion of the usable landing surface (see figure 56).

b. **Area.** Figure 57 illustrates the final approach primary and secondary areas. The primary area is longitudinally centered on the FAC and is 10 miles long. The primary area is 2.5 miles wide at the facility and expands uniformly to 6 miles wide at 10 miles from the facility. A secondary area is on each side of the primary area. It is zero miles wide at the facility, and expands uniformly to 1.34 miles on each side of the primary area at 10 miles from the facility. When the 5-mile PT is used, only the inner 5 miles of the final approach area need be considered.

c. Obstacle Clearance.

(1) **Straight-In.** The minimum obstacle clearance in the primary area is 350 feet. Exception: Military users may apply a minimum obstacle clearance in the primary area of 300 feet. In the secondary area, 350 feet (or 300 feet, as applicable) of clearance shall be provided at the inner edge, tapering uniformly to zero feet at the outer edge. To determine ROC in the secondary area, use the following formula:

$$ROC = 350 \times \frac{W_s - d}{W_s}$$

Where W_s = Width of Secondary
 d = distance from inner edge

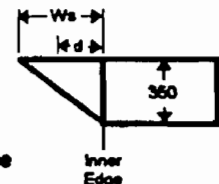

Exception: Military users utilize the following formula:

$$ROC = 300 \times \frac{W_s - d}{W_s}$$

Where W_s = Width of Secondary
 d = distance from inner edge

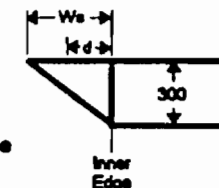

(2) **Circling Approach.** In addition to the minimum requirements specified in paragraph 613c(1), obstacle clearance in the circling area shall be as prescribed in chapter 2, section 6.

d. PT Altitude (Descent Gradient). The PT completion altitude shall be within 1,500 feet of the MDA (1,000 feet with 5 mile PT), provided the distance from the facility to the point where the FAC intersects the runway centerline (or the first usable portion of the landing area for "circling only"

procedures) does not exceed 2 miles. When this distance exceeds 2 miles, the maximum difference between the PT completion altitude and the MDA shall be reduced at the rate of 25 feet for each one-tenth of a mile in excess of 2 miles (see figure 58).

NOTE: For those procedures in which the FAC does not intersect the extended runway centerline within 3,200 feet of the runway threshold (paragraph 613a(1)), the assumed point of intersection for computing distance from the facility shall be 3,000 feet from the runway threshold (see figure 55).

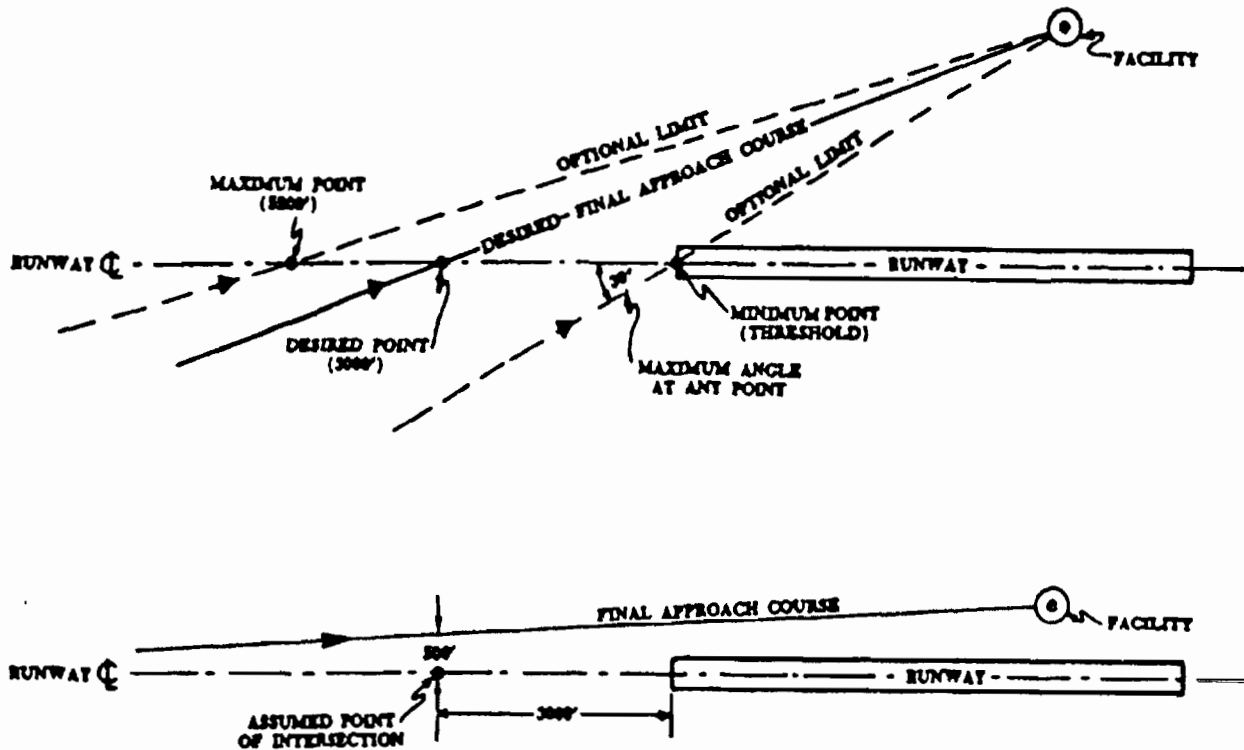

Figure 55. ALIGNMENT OPTIONS FOR FAC. On-Airport NDB. No FAF. Straight-In Procedure. Par 613a(1).

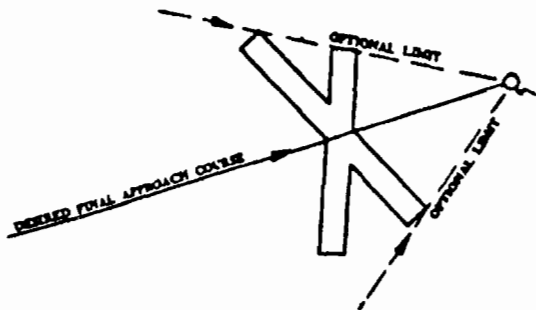

Figure 56. ALIGNMENT OPTIONS FAC.
On-Airport NDB. No FAF.
Circling Approach. Par 613a(2).

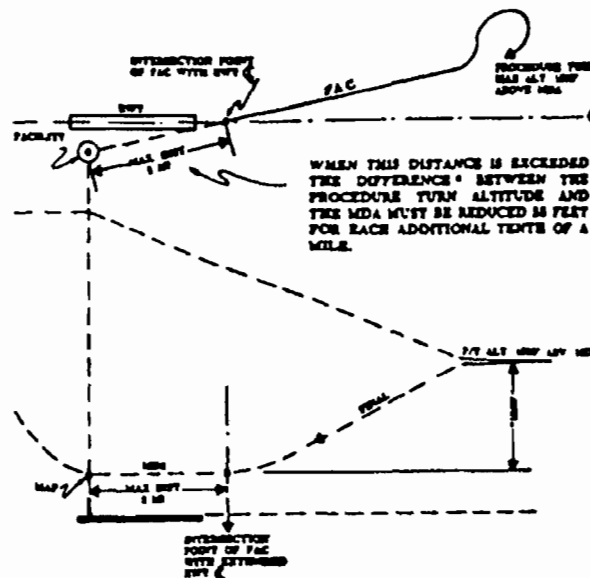

Figure 58. PT ALTITUDE.
On-Airport NDB. No FAF. Par 613d.

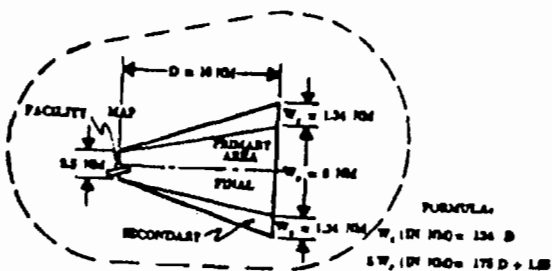

Figure 57. FINAL APPROACH PRIMARY AND
SECONDARY AREAS. On-Airport NDB.
No FAF. Par 613b.

e. Use of a Stepdown Fix. Use of a stepdown fix (paragraph 288c) is permitted provided the distance from the facility to the stepdown fix does not exceed 4 miles. The descent gradient between PT completion altitude and stepdown fix altitude shall not exceed 150 ft/NM. The descent gradient will be computed based upon the difference in PT completion altitude minus stepdown fix altitude, divided by the specified PT distance, minus the facility to stepdown fix distance. Obstacle clearance may be reduced to 300 feet (Exception: Military 250 feet) from the stepdown fix to the MAP/FEP. See figure 59, paragraphs 251, 252, and 253.

f. MDA. Criteria for determining the MDA are contained in chapter 3, section 2.

614. MISSED APPROACH SEGMENT. Criteria for the missed approach segment are contained in chapter 2, section 7. The MAP is the facility. See figure 59. The missed approach surface shall commence over the facility at the required height (see paragraph 274).

615-619. RESERVED.

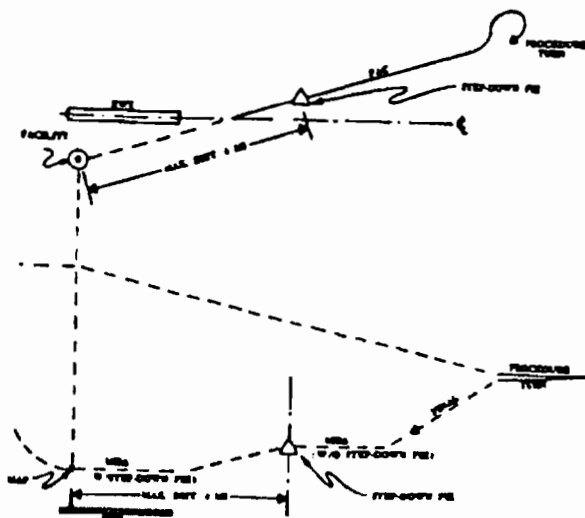

Figure 59. USE OF STEPDOWN FIX. On-Airport NDB. No FAF. Par 613c.

SECTION 2. HIGH ALTITUDE TEARDROP PENETRATIONS

620. FEEDER ROUTES. Criteria for feeder routes are contained in paragraph 220.

621. INITIAL APPROACH SEGMENT. The IAF is received by overheading the navigation facility. The initial approach is a teardrop penetration turn. The criteria for the penetration turn are contained in paragraph 235.

622. INTERMEDIATE SEGMENT. The procedure has no intermediate segment. Upon completion of the penetration turn, the aircraft is on final approach.

623. FINAL APPROACH SEGMENT. An aircraft is considered to be on final approach upon completion of the penetration turn. However, the final approach segment begins on the FAC 10 miles from the facility. That portion of the penetration procedure prior to the 10-mile point is treated as the initial approach segment (see figure 60).

a. Alignment. Same as low altitude criteria (see paragraph 613a).

b. Area. Figure 60 illustrates the final approach primary and secondary areas. The primary area is

longitudinally centered on the FAC, and is 10 miles long. The primary area is 2.5 miles wide at the facility, and expands uniformly to 8 miles at 10 miles from the facility. A secondary area is on each side of the primary area. It is zero miles wide at the facility and expands uniformly to 2 miles each side of the primary area at 10 miles from the facility.

c. Obstacle Clearance.

(1) **Straight-In.** The minimum obstacle clearance in the primary area is 500 feet. In the secondary area, 500 feet of obstacle clearance shall be provided at the inner edge, tapering to zero feet at the outer edge. The minimum ROC at any given point in the secondary area is found in paragraph 232c.

(2) **Circling Approach.** In addition to the minimum requirements specified in paragraph 623c(1), obstacle clearance in the circling area shall be as prescribed in chapter 2, section 6.

d. Penetration Turn Altitude (Descent Gradient). The penetration turn completion altitude shall be at least 1,000 feet, but not more than 4,000 feet above the MDA on final approach.

e. Use of a Stepdown Fix. Use of a stepdown fix (paragraph 288c) is permitted, provided the distance from the facility to the stepdown fix does not exceed 10 miles (see paragraph 251).

f. MDA. In addition to the normal obstacle clearance requirements of the final approach segment (see paragraph 623c), the MDA specified shall provide at least 1,000 feet of clearance over obstacles in that portion of the initial approach segment between the final approach segment and the point where the assumed penetration turn track intercepts the inbound course (see figure 60).

624. MISSED APPROACH SEGMENT. Criteria for the missed approach segment are contained in chapter 2, section 7. The MAP is the facility (see figure 60). The missed approach surface shall commence over the facility at the required height (see paragraph 274).

625.-699. RESERVED.

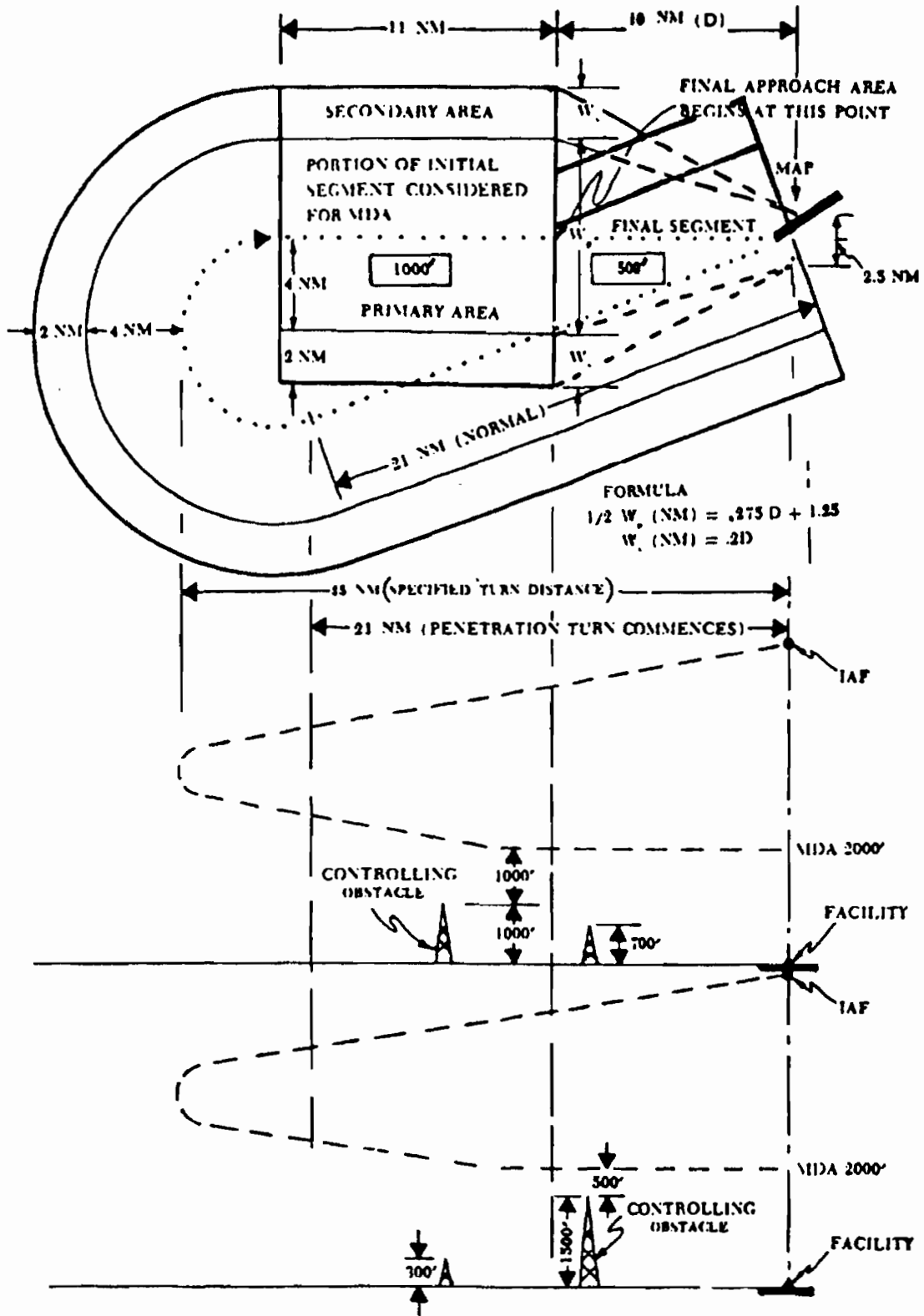

Figure 60. PENETRATION TURN. On-Airport NDB. No FAF. Par 623.

THIS PAGE INTENTIONALLY LEFT BLANK

* **CHAPTER 7. NDB WITH FAF** *

- * **700. GENERAL.** This chapter prescribes criteria for NDB procedures which incorporate a final approach fix. NDB procedures shall be based only on facilities which transmit a continuous carrier. *

701.-709. RESERVED.

Section 1. NDB With FAF

710. FEEDER ROUTES. Criteria for feeder routes are contained in paragraph 220

711. INITIAL APPROACH SEGMENT. Criteria for the initial approach are contained in Chapter 2, Section 3.

712. INTERMEDIATE APPROACH SEGMENT. Criteria for the intermediate approach segment are contained in Chapter 2, Section 4.

713. FINAL APPROACH SEGMENT. The final approach may be made either FROM or TOWARD the facility. The final approach segment begins at the final approach fix and ends at the runway or missed approach point, whichever is encountered last.

- * **NOTE:** *Criteria for the establishment of arc final approaches are specified in paragraph 523b.* *

a. Alignment. The alignment of the final approach course with the runway centerline determines whether a straight-in or circling-only approach may be established. The alignment criteria differs depending on whether the facility is OFF or ON the airport. See definition in paragraph 400.

(1) Off-Airport Facility.

(a) Straight-in. The angle of convergence of the final approach course and the extended runway centerline shall not exceed 30°. The final approach course should be aligned to intersect the runway centerline at the runway threshold. However, when an operational advantage can be achieved, the point of intersection may be established as much as 3,000 feet outward from the runway threshold. See Figure 61.

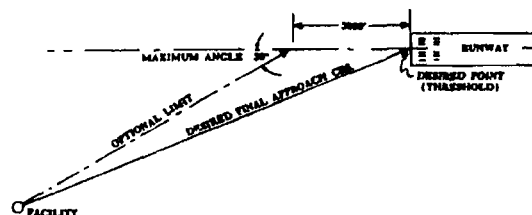

Figure 61. ALIGNMENT OPTIONS FOR FINAL APPROACH COURSE. Off-Airport NDB with FAF. Straight-in Approach. Par 713.a.(1)(a).

(b) Circling Approach When the final approach course alignment does not meet the criteria for straight-in landing, only a circling approach shall be authorized, and the alignment should be made to the center of the landing area. When an operational advantage can be achieved, the final approach course may be aligned to any portion of the usable landing surface. See Figure 62.

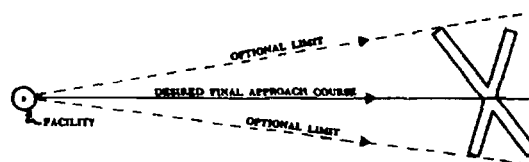

Figure 62. ALIGNMENT OPTIONS FOR FINAL APPROACH COURSE. Off-Airport NDB with FAF. Circling Approach. Par 713.a.(1)(b).

(2) On-Airport Facility.

(a) Straight-in. The angle of convergence between the final approach course and the extended runway centerline shall not exceed 30 degrees. The final approach course should be aligned to intersect the extended runway centerline 3,000 feet outward from the runway threshold. When an operational advantage can be achieved, this point of intersection may be established at any point between the runway threshold and a point 5,200 feet outward from the runway threshold. Also, where an operational advantage can be achieved, a final approach course which does not intersect

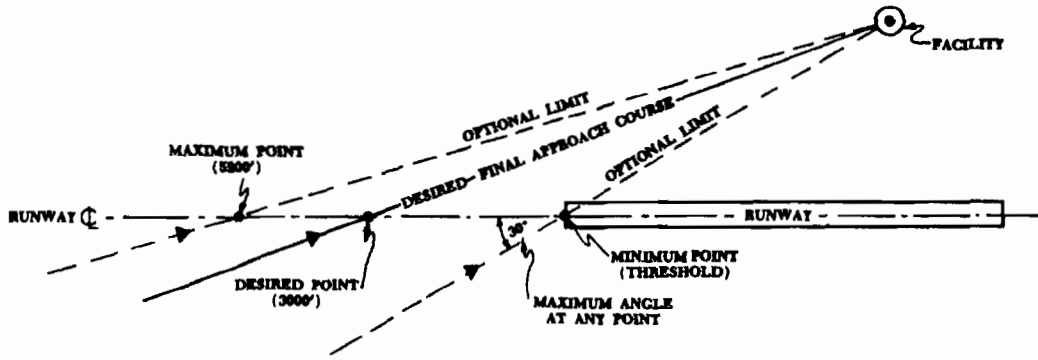

Figure 63 ALIGNMENT OPTIONS FOR FINAL APPROACH COURSE. On-airport NDB. Par 713.a.(2)(a).

the runway centerline, or which intersects it at a distance greater than 5,200 feet from the threshold, may be established provided such a course lies within 500 feet laterally of the extended runway centerline at a point 3,000 feet outward from the runway threshold. See Figure 63.

(b) *Circling Approach.* When the final approach course alignment does not meet the criteria for a straight-in landing, only a circling approach shall be authorized, and the course alignment should be made to the center of the landing area. When an operational advantage can be achieved, the final approach course may be aligned to any portion of the usable landing surface. See Figure 64.

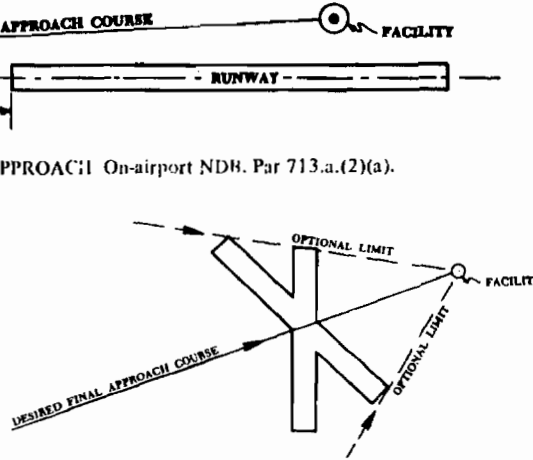

Figure 64. ALIGNMENT OPTIONS FOR FINAL APPROACH COURSE. On-Airport NDB with FAF. Circling Approach. Par 713.a.(2)(b).

b. *Area.* The area considered for obstacle clearance in the final approach segment starts at the final approach fix and ends at the runway or missed approach point, whichever is encountered last. It is a portion of a 15-mile long trapezoid (see Figure 65) which is made up of primary and secondary areas. The primary area is centered longitudinally on the final approach course. It is 2.5 miles wide at the facility and expands uniformly to 5 miles at 15 miles from the facility. A secondary area is on each side of the primary area. It is zero miles wide at the facility, and

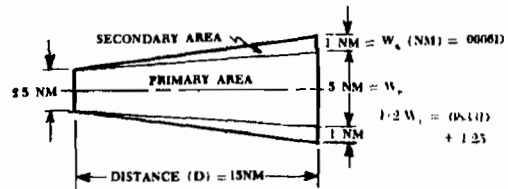

Figure 65. FINAL APPROACH TRAPEZOID. NDB with FAF. Par 713.b.

expands uniformly to 1 mile each side of the primary area at 15 miles from the facility. Final approaches may be made to airports which are a maximum of 15 miles from the facility. The OPTIMUM length of the final approach segment is 5 miles. The MAXIMUM length is 10 miles. The MINIMUM length of the final approach segment shall provide adequate distance for an aircraft to make the required descent, and to regain course alignment when a turn is required over the facility. The following table shall be used to determine the minimum length needed to regain the course.

Table 15. MINIMUM LENGTH OF FINAL APPROACH SEGMENT - NDB (Miles)

Approach Category	Magnitude of Turn over Facility (Degrees)		
	10	20	30
A	1.0	1.5	2.0
B	1.5	2.0	2.5
C	2.0	2.5	3.0
D	2.5	3.0	3.5
E	3.0	3.5	4.0

NOTE: This table may be interpolated. If turns of more than 30° are required, or if the minimum lengths specified in the table are not available for the procedure, straight-in minimums are NOT authorized. See figure 66 for typical final approach areas.

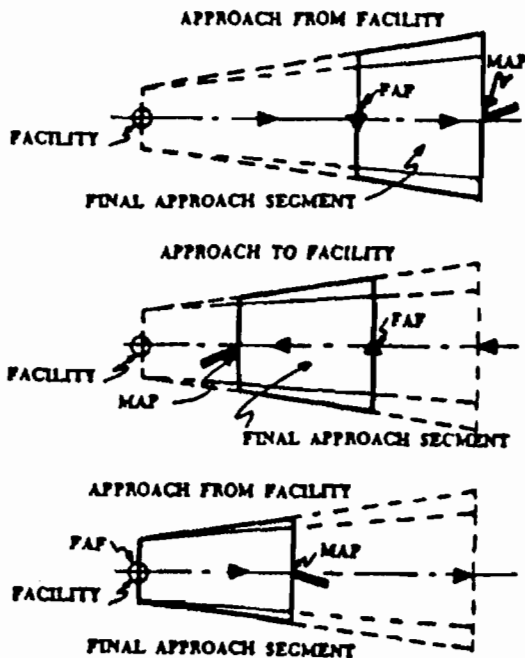

Figure 66. TYPICAL FINAL APPROACH AREAS. NDB with FAF. Par 713b.

c. Obstacle Clearance.

(1) **Straight-In.** The minimum obstacle clearance in the primary area is 300 feet. Exception: Military users may apply a minimum obstacle clearance in the primary area of 250 feet. In the secondary area, 300 feet (or 250 feet, as applicable) of obstacle clearance shall be provided at the inner edge, tapering uniformly to zero feet at the outer edge. The minimum ROC at any given point in the secondary area is:

$$ROC = 300 \times \frac{Ws - d}{Ws}$$

Where Ws = Width of Secondary
 d = distance from inner edge

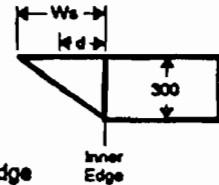

Exception: Military users utilize the formula to determine ROC in the secondary area. Annotate joint civilian/military SIAP's that civilian users add 50 feet to all minimums if 250 ROC is used.

$$ROC = 250 \times \frac{Ws - d}{Ws}$$

Where Ws = Width of Secondary
 d = distance from inner edge

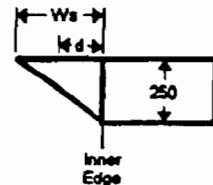

(2) **Circling Approach.** In addition to the minimum requirements specified in paragraph 713c(1), obstacle clearance in the circling area shall be as prescribed in chapter 2, section 6.

d. Descent Gradient. Paragraph 252 applies.

e. Use of Fixes: Criteria for the use of radio fixes are contained in chapter 2, section 8. Where a procedure is based on a PT and an on-airport facility is the PT fix, the distance from the facility to the FAF shall not exceed 4 miles.

f. MDA. Criteria for determining the MDA are contained in chapter 3, section 2.

714. MISSED APPROACH SEGMENT. Criteria for the missed approach segment are contained in chapter 2, section 7. The MAP and surface shall be established as follows:

a. Off-Airport Facilities.

(1) **Straight-In.** The MAP is a point on the FAC which is NOT FARTHER from the FAF than the runway threshold. The missed approach surface shall commence over the MAP at the required height (see paragraph 274 and figure 67).

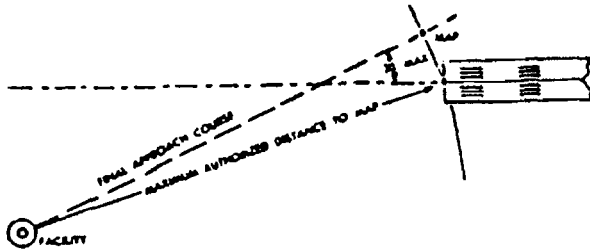

Figure 67. MAP.
Off-Airport NDB with FAF. Par 714a(1).

(2) **Circling Approach.** The MAP is a point on the FAC which is NOT FARTHER from the FAF than the first usable portion of the landing area. The missed approach surface shall commence over the MAP at the required height (see paragraph 274).

b. **On-Airport Facilities.** The MAP is a point on the FAC which is NOT FARTHER from the FAF than the facility. The missed approach surface shall commence over the MAP at the required height (see paragraph 274).

715.-799. RESERVED.

CHAPTER 8. VHF/UHF DF PROCEDURES

800. GENERAL. These criteria apply to direction finder (DF) procedures for both high and low altitude aircraft. DF criteria shall be the same as criteria provided for automatic direction finder (ADF) procedures, except as specified herein. As used in this chapter, the word "facility" means the DF antenna site. DF approach procedures are established for use in emergency situations. However, where required by a using agency, DF may be used for normal instrument approach procedures.

801.-809. RESERVED.

Section 1. VHF/UHF DF Criteria

810. EN ROUTE OPERATIONS. En route aircraft under DF control follow a course to the DF station as determined by the DF controller. A minimum safe altitude shall be established which provides at least 1,000 feet (2,000 feet in mountainous areas) of clearance over all obstacles within the operational radius of the DF facility. When this altitude proves unduly restrictive, sector altitudes may be established to provide relief from obstacles, which are clear of the area where flight is conducted. Where sector altitudes are established, they shall be limited to sectors of not less than 45 degrees in areas BEYOND a 10-mile radius around the facility. For areas WITHIN 10 miles of the facility, sectors of NOT LESS THAN 90 degrees shall be used. Because the flight course may coincide with the sector division line, the sector altitude shall provide at least 1,000 feet (2,000 feet in mountainous terrain) of clearance over obstacles in the adjacent sectors within 6 miles or 20 degrees of the sector division line, whichever is the greater. No sector altitude shall be specified which is lower than the procedure or penetration turn altitude or lower than the altitude for area sectors, which are closer to the navigation facility.

811. INITIAL APPROACH SEGMENT. The initial approach fix is overhead the facility.

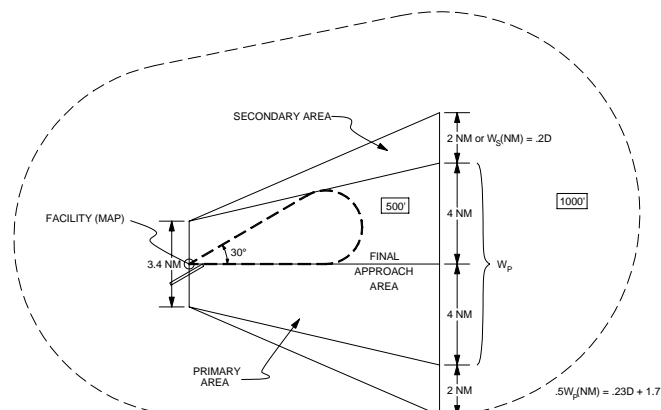

Figure 72. LOW ALTITUDE DF APPROACH AREA, Par 811.

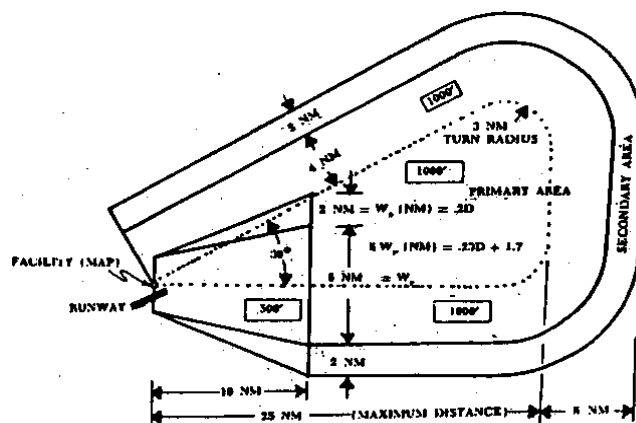

Figure 73. HIGH ALTITUDE DF APPROACH AREA, Par 811.

a. Low Altitude Procedures. The initial approach may be either a 10-mile teardrop procedure turn or the triangular procedure illustrated in figure 72. In either case, the 10-mile procedure turn criteria contained in paragraphs 234a, b, c, and d apply.

b. High Altitude Procedures. The initial approach may be either the standard teardrop penetration turn or the triangular procedure illustrated in figure 73. When the teardrop penetration turn is used, the criteria contained in paragraphs 235a, b, c, and d apply. When the triangular procedure is used, the same criteria apply except that the limiting angular divergence between the outbound course and the reciprocal

of the in bound course may be as much as 45 degrees.

812. INTERMEDIATE APPROACH SEGMENT. Except as outlined in this paragraph, criteria for the intermediate segment are contained in chapter 2, section 4. An intermediate segment is used only when the DF facility is located off the airport and the final approach is made from overhead the facility to the airport. The width of the primary intermediate area is 3.4 miles at the facility, expanding uniformly on each side of the course to 8 miles wide 10 miles from the facility. A secondary area is on each side of the primary area. It is zero miles wide at the facility, expanding along the primary area to 2 miles each side at 10 miles from the facility. See figure 74.

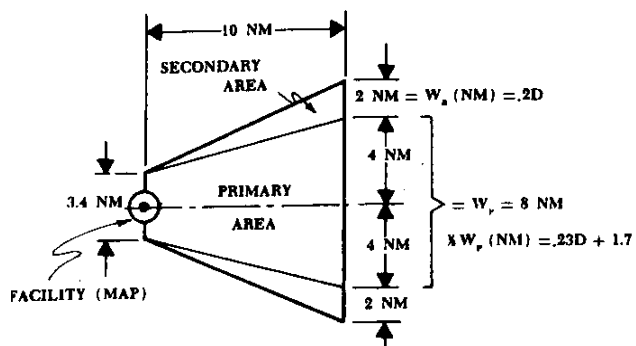

Figure 74. DF INTERMEDIATE APPROACH AREA. Par 812.

813. FINAL APPROACH SEGMENT. The final approach begins at the facility for off-airport facilities or where the procedure turn intersects the final approach course for on-airport facilities (see paragraph 400 for the definition of on-airport facilities). DF procedures shall not be developed for airports that are more than 10 miles from the DF facility. When a facility is located in excess of 6 miles from an airport, the instrument approach shall end at the facility and flight to the airport shall be conducted in accordance with visual flight rules (VFR).

a. Alignment.

(1) On - Airport Facilities. Paragraphs 613a(1) and (2) apply.

(1) Off - Airport Facilities. Paragraphs 713a(1)(a) and (b) apply.

b. Area.

(1) Low Altitude Procedures.

Figure 74 illustrates the final approach primary and secondary areas. The primary area is longitudinally centered on the final approach course and is 10 miles long. The primary area is 3.4 miles wide at the facility and expands uniformly to 8 miles wide at 10 miles from the facility. A secondary area is on each side of the primary area. It is zero miles wide at the facility and expands uniformly to 2 miles on each side of the primary area at 10 miles from the facility.

(2) High Altitude Procedures.

The area considered is identical to that described in paragraph 623 b and figure 60 except that the primary area is 3.4 miles wide at the facility.

c. Obstacle Clearance.

(1) Straight-In.

The minimum obstacle clearance in the primary area is 500 feet. In the secondary areas, 500 feet of obstacle clearance shall be provided at the inner edge, tapering to zero feet at the outer edge. The minimum required obstacle clearance at any given point in the secondary area can be computed by using the formula specified in paragraph 523b.

(2) Circling Approach.

In addition to the minimum requirements specified in paragraph 813c(1), obstacle clearance in the circling area shall be as prescribed in chapter 2, section 6.

d. Procedure Turn Altitude. The procedure turn completion altitude (minimum base leg altitude in triangular procedures) shall be within 1,500 feet of the MDA on final approach.

e. Penetration Turn Altitude (Descent Gradient). The penetration turn altitude (minimum base leg altitude in triangular procedures) shall be at least 1,000 feet but not more than 4,000 feet above the MDA on final approach.

f. Minimum Descent Altitude (MDA).

The criteria for determining MDA are contained in chapter 3, section 2, except that in high altitude procedures, the MDA specified shall provide at least 1,000 feet of clearance over obstacles in that portion of the initial approach segment between the final approach segment and the point where the assumed penetration course intercepts the inbound course (see figure 60).

814. MISSED APPROACH SEGMENT.

Criteria for the missed approach segment are contained in chapter 2, section 7. For on-airport facility locations, the missed approach point is the facility. For off-airport facility locations, the missed approach point is a point on the final approach course which is NOT farther from the facility than the first usable landing surface. The missed approach surface shall commence over the missed approach point at the required height (see paragraph 274).

815.-819. RESERVED.**Section 2. Communications.**

820. TRANSMISSION INTERVAL. DF navigation is based on voice transmission of

heading and altitude instructions by a ground station to the aircraft. The MAXIMUM interval between transmissions is:

a. En route Operations. 60 seconds.

b. From the Initial Approach Fix to Within an Estimated 30 Seconds of the Final Station Passage or Missed Approach Point. 15 seconds

c. Within 30 Seconds of the Final Station Passage or Missed Approach Point. 5 seconds. (15 seconds for doppler DF equipment).

821.-829. RESERVED.**Section 3. Minimums.**

830. APPROACH MINIMUMS. The minimums established for a particular airport shall be as prescribed by the appropriate approving agency, but the MDA shall NOT be lower than that required for obstacle clearance on final approach and in the circling area specified in chapter 2, section 6.

831.-899. RESERVED.

THIS PAGE INTENTIONALLY LEFT BLANK

CHAPTER 9. LOCALIZER AND LOCALIZER TYPE DIRECTIONAL AIDS (LDA)

900. FEEDER ROUTES, INITIAL APPROACH, AND INTERMEDIATE SEGMENTS.

These criteria are contained in chapter 2, Section 3. When associated with a precision approach procedure, Volume 3, paragraph 2.3 applies.

901. USE OF LOCALIZER ONLY.

Where no usable glidepath is available, a localizer-only (front or back course) approach may be approved, provided the approach is made on a LOC from a FAF located within 10 miles of the runway threshold. Criteria in this section are also applicable to procedures based on localizer type directional aids (LDA). Back course procedures shall not be based on courses that exceed 6° in width and shall not be approved for offset LOC.

902. ALIGNMENT.

Localizers which are aligned within 3° of the runway alignment shall be identified as localizers. If the alignment exceeds 3°, they will be identified as LDA facilities. The alignment of the course for LDA facilities shall meet the final approach alignment criteria for VOR on-airport facilities. See chapter 5, paragraph 513, and figure 48.

903. AREA.

The final approach dimensions are specified in figure 75. However, only that portion of the final approach area that is between the FAF and the runway need be considered as the final approach segment for obstacle clearance purposes. The optimum length of the final approach segment is 5 miles. The MINIMUM length of the final approach segment shall be sufficient to provide adequate distance for an aircraft to make the required descent. The area shall be centered on the FAC and shall commence at the runway threshold. For LDA procedures, the final approach area shall commence at the facility and extend to the FAF. The MAP for LDA procedures shall not be farther from the FAF than a point adjacent to the landing threshold perpendicular to the FAC. Calculate the width of the area using the following formulae:

Perpendicular Width from RCL to the Edge of the Primary = $0.10752(D - 200) + 700$

Perpendicular Width from RCL to the Edge of the Transitional Sfc = $0.15152(D - 200) + 1000$

Where D = Distance (ft) from RWT measured along RCL

904. OBSTACLE CLEARANCE. The minimum ROC in the final approach area is 250 feet. In addition, the MDA established for the final approach area shall assure that no obstacles penetrate the 7:1 transitional surfaces.

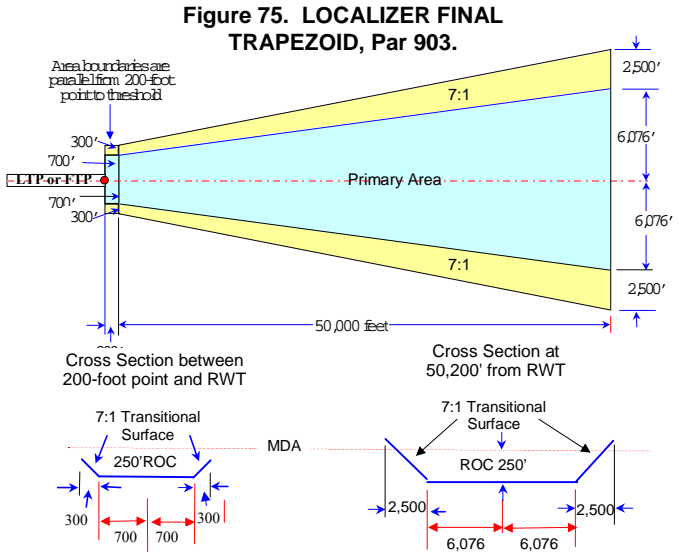

905. DESCENT GRADIENT.

The OPTIMUM gradient in the final approach segment is 318 feet per mile. Where a higher descent gradient is necessary, the MAXIMUM permissible gradient is 400 feet per mile. When maximum straight-in descent gradient is exceeded, then a "circling only" procedure is authorized. When a stepdown fix is incorporated, descent gradient criteria must be met from FAF to SDF and SDF to FEP. See paragraphs 251, 252, and 288a.

906. MDA. The lowest altitude on final approach is specified as an MDA. The MDA adjustments specified in paragraph 232 shall be considered.

907. MISSED APPROACH SEGMENT. The criteria for the missed approach segment are contained in chapter 2, section 7. The MAP is on the FAC not farther from the FAF than the runway threshold (first usable portion of the landing area for circling approach). The missed approach surface shall commence over the MAP at the required height (see paragraph 274).

908.-909. RESERVED

Policy
Memo
Dec 28
2007

THIS PAGE INTENTIONALLY LEFT BLANK

Chapter 10. Radar Approach Procedures and Vectoring Charts

Section 1. General Information.

10.0 General.

This chapter applies to radar approach procedures and vectoring charts utilizing ground-based radar or other approved surveillance systems (i.e., satellite-based). The types of systems supported are:

10.0.1 Precision Approach Radar (PAR) is a system that graphically displays lateral course, glidepath, and distance from touchdown information of sufficient accuracy, continuity, and integrity to provide precision approach capability to a runway/landing area.

10.0.2 Surveillance Radar is a system that displays direction and distance information with suitable accuracy, continuity, and integrity to safely provide radar vectoring capability for departures, arrivals, en route operations, and Nonprecision Approach (NPA) Airport Surveillance Radar (ASR) approaches to an airport. For the purpose of these criteria, the minimum lateral clearance between aircraft and obstacles are:

10.0.2 a. Single Sensor describes adaptations based on the input of a single radar site and includes single sensor long-range radar mode. May apply to the entire radar display or within a defined area on the radar display.

- When the aircraft is less than *40 nautical miles (NM) from the antenna, minimum lateral clearance is 3 NM.
- When the aircraft is *40 NM or more from the antenna, minimum lateral clearance is 5 NM.

**60 NM for approved full time reinforced Monopulse Secondary Surveillance Radar (MSSR) systems.*

10.0.2 b. Multi Sensor describes adaptations based on the input of multiple radar sites and includes Mosaic Mode, Multi-Sensor Mode, Stage A/DARC, Fusion Mode, and Center Radar ARTS Presentation (CENRAP). May apply to the entire radar display or within a defined area of a radar display.

- Minimum lateral clearance is 5 NM.

10.0.3 Automatic Dependent Surveillance - Broadcast (ADS-B) [TBD].

Chapter 10. Radar Approach Procedures and Vectoring Charts

Section 2. Radar Approaches.

10.1 Radar Approaches.

Both ASR and PAR approach procedures may be established where the applicable Order 8200.1, *U. S. Standard Flight Inspection Manual*, coverage and alignment tolerances are met. ASR approaches may be established when the final segment is adapted for single sensor operations and the radar antenna is not more than 20 NM from;

- The approach runway threshold (RWT) coordinates when the procedure is designed to meet straight-in alignment.
- The Airport Reference Point (ARP) when the procedure is designed to meet circling-only alignment.

10.1.1 Feeder Routes and Initial Approach Segments.

Feeder and initial segments do not need to be established when navigation guidance and obstacle clearance are provided by Air Traffic Control radar vectors during the transition from the enroute to the terminal phase of flight.

10.1.1 a. Feeder/Initial Segments based on Routes [Department of Defense (DoD) Only].

When operationally required, establish feeder routes and/or initial segments based on conventional navigation, Area Navigation (RNAV), or radar routes.

10.1.1 a. (1) Conventional/RNAV Feeder/Initial. Develop in accordance with **TERPS** Volume 1, chapter 2 or Order 8260.54, *United States Standard for Area Navigation (RNAV)*, chapter 2.

10.1.1 a. (2) Radar Feeder/Initial. The route/segment begins at an established fix that permits positive radar identification and ends at the appropriate termination fix for the segment. Display the course centerline on a radar video map (e.g., as a “special use” track per Order 7210.3, *Facility Operation and Administration*, chapter 3, section 8 or DoD equivalent).

10.1.1 a. (2) (a) Alignment. Design feeder/initial and initial/initial segment intersections with the smallest amount of course change necessary for the procedure. The maximum allowable course change between segments is 90 degrees.

10.1.1 a. (2) (b) Area. The Obstacle Evaluation Area (OEA) begins at the applicable radar fix displacement prior to the route/segment start fix and extends to the

segment termination fix. Primary area half-width is equal to the minimum lateral clearance applicable to the radar adaptation (*TERPS*, Vol.1, chapter 10, paragraph 10.0.2) from course centerline. There is no secondary area. The area has no specified maximum or minimum length; however, the segment must be long enough to permit the required altitude loss without exceeding the maximum authorized descent gradient.

Note: When the minimum lateral clearance changes within a segment (e.g. when transitioning from a multi- to single-sensor adaptation, or at the applicable distance for a single-sensor adaptation), the OEA half-width also changes without the need to “splay” or “taper”.

- 10.1.1 a. (2) (c) Obstacle Clearance. Apply the *TERPS* Volume 1, chapter 2 standard applicable to the segment. *TERPS* Volume 1, chapter 3 precipitous terrain adjustments apply
- 10.1.1 a. (2) (d) Descent Angle. Apply *TERPS* Volume 1, chapter 2 standard applicable to the segment.
- 10.1.1 a. (2) (e) Altitude Selection. Apply *TERPS* Volume 1, chapter 2 standard applicable to the segment. Do not publish fix altitudes higher than the minimum required for obstacle clearance or airspace to achieve an “*optimum*” descent gradient.
- 10.1.2 Intermediate Approach Segment.** Establish an intermediate segment when necessary (e.g., ATC radar vectors not available or MVA too high to support desired FAF/PFAF altitude). The intermediate segment begins at the intermediate fix and extends to the PFAF. When there is a preceding conventional /RNAV route segment, the applicable conventional/RNAV intermediate segment standards apply, except as specified in *TERPS*, Vol 1, chapter 10, paragraph 10.1.2b(2).
- 10.1.2 a. Alignment.** The intermediate course is an extension of the final approach course (no course change permitted at the PFAF).
- 10.1.2 b. Area.**
- 10.1.2 b. (1) Radar Intermediate. When radar is used for course guidance (route or vector), the OEA begins at the applicable radar fix displacement prior to the Intermediate Fix (IF) and extends to the PFAF. Primary area half-width is equal to the minimum lateral clearance applicable to the radar adaptation (*TERPS*, Volume1, chapter 10, paragraph 10.0.2) until reaching a point 2 NM prior to the PFAF, then tapers to the width of the ASR/PAR/PAR without glideslope Final Approach Segment (FAS) primary OEA width abeam the PFAF (*TERPS*, Volume 1, chapter 10, paragraph 10.1.4 and *TERPS*, Volume 3, chapter 3, paragraph 3.0) (USN NA). There are no intermediate secondary areas. *See figure 10-1.*

Note: When the minimum lateral clearance changes within a segment (e.g. when transitioning from a multi- to single-sensor adaptation, or at the applicable distance for a single-sensor adaptation), the OEA half-width also changes without the need to “splay” or “taper”.

- 10.1.2 b. (2) Non-Radar Intermediate. When conventional/RNAV navigation is used for course guidance, apply the intermediate OEA criteria from the applicable 8260-series order with the following exceptions:
- 10.1.2 b. (2) a. Connection to PAR Final. Connect the outer edges of the intermediate primary area abeam the IF to the outer edges precision “X” Obstacle Clearance Surface (OCS) and the intermediate secondary area to the precision “Y” OCS abeam the PFAF.
- 10.1.2 b. (2) b. Connection to ASR Final. Connect the outer edges of the intermediate primary and secondary areas abeam the IF to the outer edge of the ASR area abeam the PFAF.

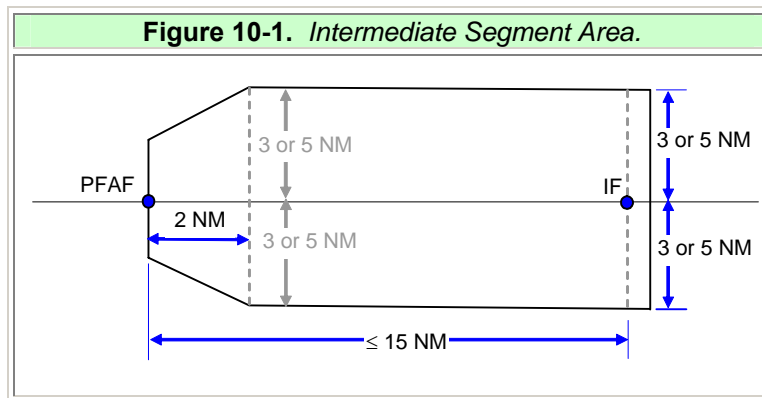

- 10.1.2 b. (3) Length. The intermediate segment length is normally 6 NM. The MINIMUM length varies based on course guidance but must always accommodate the required altitude loss. The *maximum* length is 15 NM.
- 10.1.2 b. (3) a. For conventional/RNAV and radar route course guidance, apply **TERPS**, Volume 1, chapter 2 for ASR approaches and **TERPS**, Volume 3, chapter 2 for PAR approaches. Radar intermediate segments may not be less than 2 NM.
- 10.1.2 **c. Obstacle Clearance.** Apply 500 ft ROC over the highest obstacle in the area. **TERPS**, Volume 1 chapter 3 precipitous terrain and RASS adjustments apply. For conventional/RNAV course guidance, apply secondary area ROC criteria from the applicable 8260-series directive.

10.1.2 **d. Descent gradient.** Apply *TERPS*, Volume 1, chapter 2.

10.1.3 **PAR Final Approach Segment (FAS).**

10.1.3 **a. Inoperative/unused Components.** Failure of the azimuth component renders the entire PAR system inoperative. When the elevation component (glidepath) fails or is not used (i.e., to support pilot or controller training) the PAR azimuth may be used to provide an ASR approach. A stand-alone PAR azimuth without glideslope procedure is not required when ASR minimums are established to the same runway and used during the approach, the missed approach instructions are the same, and the ASR missed approach point is identifiable on the PAR scope.

Alternatively, a separate PAR azimuth without glideslope procedure may be established when required and/or operationally advantageous. Evaluate using the localizer area and obstacle clearance requirements specified in *TERPS*, Volume 1, chapter 9. NPA minimums are established according to *TERPS*, Volume 1, chapter 3, section 3 and documented in accordance with applicable directives.

10.1.3 **b. General.** Apply the current basic vertically guided final segment general criteria applicable to Instrument Landing System (ILS) for Glidepath Angle (GPA), Threshold Crossing Height (TCH), Precise Final Approach Fix (PFAF), Glidepath Qualification Surface (GQS), and Precision Obstacle Free Zone (POFZ).

10.1.3 b. (1) Use the highest applicable MVA to determine the PFAF distance to LTP/coordinates when there is no preceding segment.

10.1.3 b. (2) ILS Height Above Touchdown/Threshold (HAT/HATh) and Decision Altitude (DA) standards apply (to include *TERPS* Volume 1, chapter 3 adjustments), except the *minimum* HAT/HATh may be 100 ft for DoD-only approaches when the OCS is clear. Adjusting TCH to reduce/eliminate OCS penetrations is not applicable to PAR FAS evaluations.

10.1.3 **c. Obstacle Evaluation Area (OEA)/Obstacle Clearance Surface (OCS).** [USN: See applicable directives.] Apply current ILS FAS criteria for alignment, OCS slope, width, height, and OEA/OCS evaluation *except* the OEA extends to the PFAF (no radar fix tolerance applied). Also, where the PFAF must be located more than 50,200 ft from the RWT coordinates, the OEA continues to splay to the PFAF or until reaching the minimum lateral clearance applicable to the radar adaptation (*TERPS*, Volume 1, Chapter 10, paragraph 10.0.2).

10.1.3 **d. Simultaneous PAR Procedures (DoD only).** Where military authority determines facilities and equipment are adequate, PAR approach procedures to parallel runways may be established. See applicable DoD directives.

- 10.1.4 ASR Final Approach Segment (FAS).** Use the highest applicable MVA to determine the PFAF location when there is no preceding segment.
- 10.1.4 a. General.** Apply the current non-vertically guided final segment general criteria.
- 10.1.4 b. Alignment.** Align the Final Approach Course (FAC) with the extended runway centerline for a straight-in approach, or to the airport reference point for a circling approach. When an operational advantage can be achieved, the FAC for circling approaches may be aligned to pass through any portion of the usable landing surface.
- 10.1.4 c. Area.** The final approach begins at the applicable radar fix displacement prior to the PFAF and ends at the RWT (straight-in)/FEP (circling) or the appropriate radar fix displacement beyond the Missed Approach Point (MAP), whichever is encountered last.
- 10.1.4 c. (1) Determine the primary area half-width ($\frac{1}{2}W_p$) using *formula 10-1*. Connect the width calculated at the PFAF to the width calculated at the RWT/FEP (straight line connection). The width at the early or late fix displacement points is equal to the width at the PFAF and RWT/FEP. *See figure 10-2.*

Formula 10-1. Final Area Half-Width at PFAF and RWT/FEP (H_w).

$$H_w = 0.1 \cdot D + 1$$

where

D = Distance, FAC point to Antenna (NM)

($H_w = 3$ NM where $D > 20$ NM)

$$0.1 \cdot D + 1$$

- 10.1.4 c. (2) When the distance of any point on FAC centerline > 20 NM, the primary area $\frac{1}{2}W_p$ is 3 NM. *See figure 10-2.*

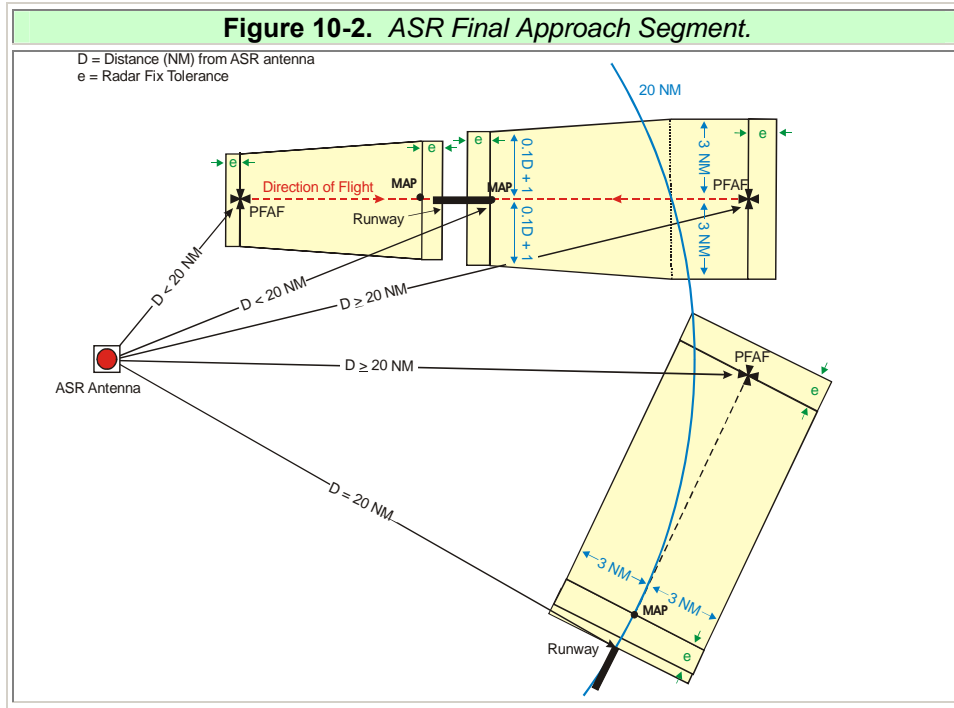

- 10.1.4 d. **Length.** The segment must provide sufficient length to accommodate required altitude loss. The *minimum* length is 3 NM and *maximum* length is 10 NM.
- 10.1.4 e. **Obstacle Clearance.** Apply 250 ft **ROC** to the highest obstacle in the area. **TERPS** Volume 1, chapter 3 precipitous terrain, remote altimeter, and excessive length of final adjustments apply.
- 10.1.4 f. **Descent Angle.** Apply current NPA criteria, except do not publish the VDA.
- 10.1.4 g. **Recommended Altitudes (RecAlt).** Determine recommended altitudes at each mile on final approach for ATC use. Determine RecAlt values using *formula 10-2*.

Formula 10-2. Recommended Altitudes (RecAlt).

$$RecAlt = A - DG$$

where
 A = PFAF altitude or Last RecAlt (unrounded)
 DG = $(1852/0.3048) \times \tan [VDA \text{ calculated per Vol. 1, Chap. 2, para 252}]$

A-DG

RecAlt values below MDA are not issued. Round recommended altitudes to the **nearest** 20-ft increment. See the examples below.

Example:

PFAF altitude = 2,000', MDA = 660', VDA = 3.00° (318.436/NM)

6 NM (PFAF) = 2,000'

5 NM recommended altitude: $2,000 - 318.436 = 1,681.564$ (1,680)

4 NM recommended altitude: $1,681.564 - 318.436 = 1,363.128$ (1,360)

3 NM recommended altitude: $1,363.128 - 318.436 = 1,044.692$ (1,040)

2 NM recommended altitude: $1,044.692 - 318.436 = 726.256$ (720)

1 NM recommended altitude: $726.256 - 318.436 = 407.82$ (Not issued)

- 10.1.4 h. RecAlt with Stepdown Fix above the VDA .** When the minimum altitude at a stepdown fix is above the vertical path of the VDA, calculate RecAlt using the appropriate VDA for each subsegment (i.e., VDA from PFAF to stepdown altitude prior to stepdown fix, and VDA from stepdown altitude to TCH after the stepdown fix).

Example _____:

PFAF altitude = 3,300', MDA = 1,400', VDA PFAF to stepdown fix = 3.00° (318.436/NM), VDA at 4 NM SDF to TCH = 3.39° (359.924/NM)

6 NM (PFAF) = 3,300

5 NM recommended altitude: $3,300 - 318.436 = 2,981.564$ (2,980)

4 NM recommended altitude: $2,981.564 - 318.436 = 2,663.128$ (2,660)

3 NM recommended altitude: $2,663.128 - 359.924 = 2,303.204$ (2,300)

2 NM recommended altitude: $2,303.204 - 359.924 = 1,943.280$ (1,940)

1 NM recommended altitude: $1,943.280 - 359.924 = 1,583.356$ (1,580)

10.1.5 Missed Approach Segment (MAS).

- 10.1.5 a. PAR.** Apply the current *TERPS*, Volume 3 Category (CAT) I ILS missed approach criteria to approaches with HAT/HATh values greater than or equal to 200 ft. Apply current CAT II ILS missed approach criteria for approaches with HAT/HATh values lower than 200 ft, except USN approaches annotated "Not for Civil Use".

- 10.1.5 b. ASR.** Apply the current *TERPS*, Volume 1, chapter 2 NPA missed approach criteria. The MAP is located on the final approach course not farther from the PFAF than the FEP.

Chapter 10. Radar Approach Procedures and Vectoring Charts (MVAC)

Section 3. Minimum Vectoring Altitude Charts.

10.2 **Minimum Vectoring Altitude Chart (MVAC).** An MVAC is used by air traffic facilities when providing terminal service. An MVAC may be developed by En Route facilities in selected areas where the MIA chart does not meet operational needs. An MVAC specifies the lowest MSL altitude at or above the floor of controlled airspace that provides at least the minimum ROC over obstacles. The MVAC may be used in lieu of feeder, initial, and intermediate approach segment(s) for radar approaches.

Note: See Orders 7210.3, Facility Operations and Administration, 7210.37, En Route Minimum IFR Altitude (MIA) Sector Charts, or DoD directive.

10.2.1 **General.** Apply current Order 7210.3 criteria (or applicable DoD directive) to determine when an MVAC is required, the range/coverage of the chart(s) and the lateral obstacle clearance applicable to the chart and/or specific sectors. When the area of responsibility is beyond the radar system limits but a vectoring chart is still operationally necessary, apply Order 7210.37 for the non-radar area.

Note: The current vertical and horizontal obstacle accuracy standards in Order 8260.19 apply.

10.2.2 **Single Sensor Adaptation.** Center the MVAC on the radar sensor to facilitate distance measurements (e.g., to determine the minimum lateral clearance). Define sector boundaries by bearings, point-to-point lines, arcs, and/or circles relative to a specified point or points (e.g., radar antenna, NAVAID, fix, latitude/longitude coordinate, etc.). *See figure 10-3.*

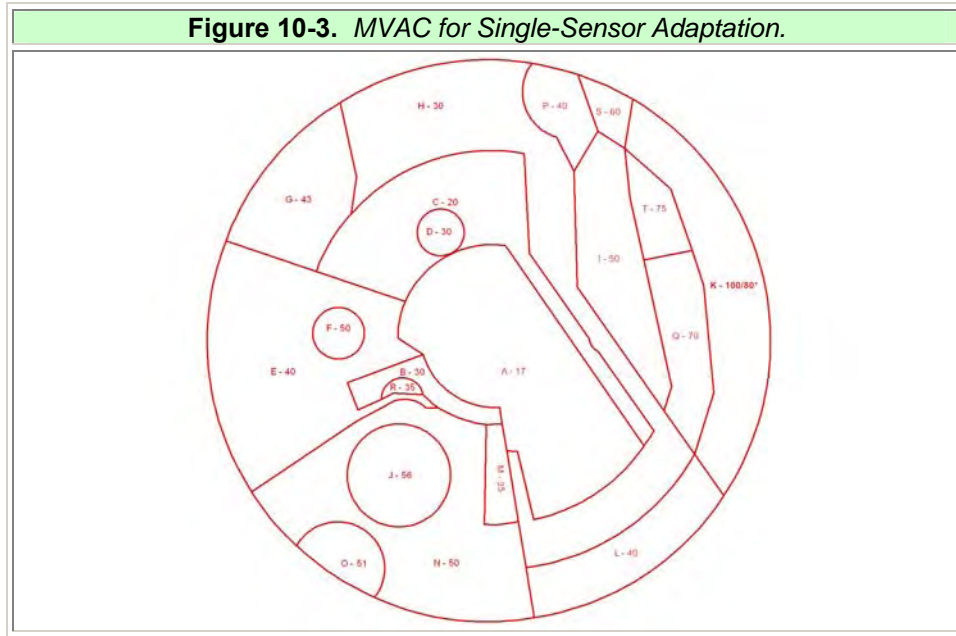

- 10.2.3 Multi-sensor Adaptation.** Sector boundaries may be defined by any combination of bearings, point-to-point lines, arcs, and/or circles relative to a specified point or points (e.g., radar antenna, NAVAID, fix, latitude/longitude coordinate, etc.). See figure 10-4.

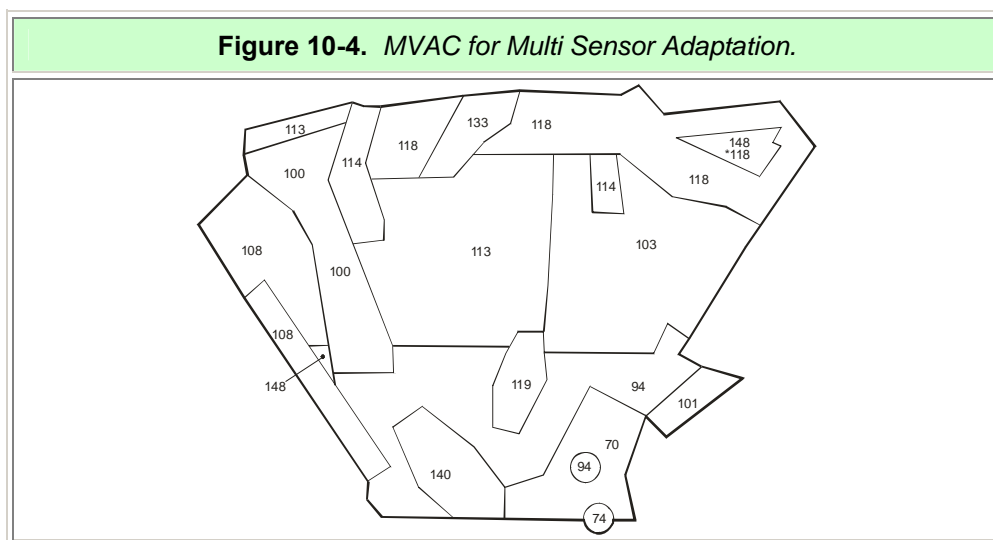

- 10.2.4 Sectors.** The MVAC may be subdivided into sectors to gain relief from obstacles. There is no prescribed limit on the size, shape, or orientation of MVAC sectors. **Where small contiguous sectors with different altitudes do not serve an operational need, consider combining them.**
- 10.2.4 a. Obstacle Evaluation Area.** Adjacent sectors share common boundaries; however, each sector OEA is stand-alone and evaluated separately. The sector

OEA includes the volume of airspace contained within its defined boundaries. Except for isolation areas (see *TERPS*, Volume 1, chapter 10, paragraph 10.2.4b), each sector includes a buffer equal to the minimum required lateral clearance for the applicable radar adaptation.

10.2.4

a. (1) Single Sensor. An OEA buffer expands outward at least 3 NM from those portions of the boundary within *40 NM of the radar antenna and at least 5 NM outward from those portions of the boundary equal to or greater than *40 NM from the radar antenna. When a contiguous sector **crosses** *40 NM from the radar antenna, the sector is effectively divided into sub-sectors at the *40 NM arc and normal OEA/buffers applied to each, except buffers expanding INTO the sector may be truncated at the boundary. The highest altitude from each sub-sector applies. See figures 10-5/5a.

**60 NM for approved full time reinforced MSSR systems.*

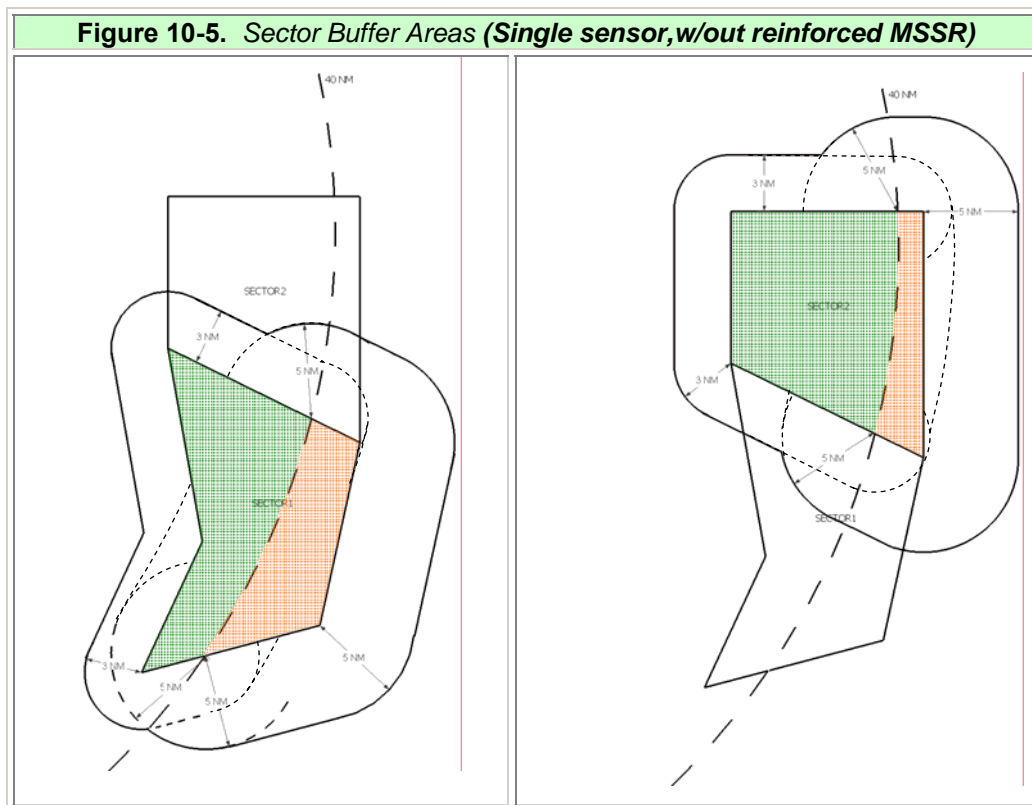

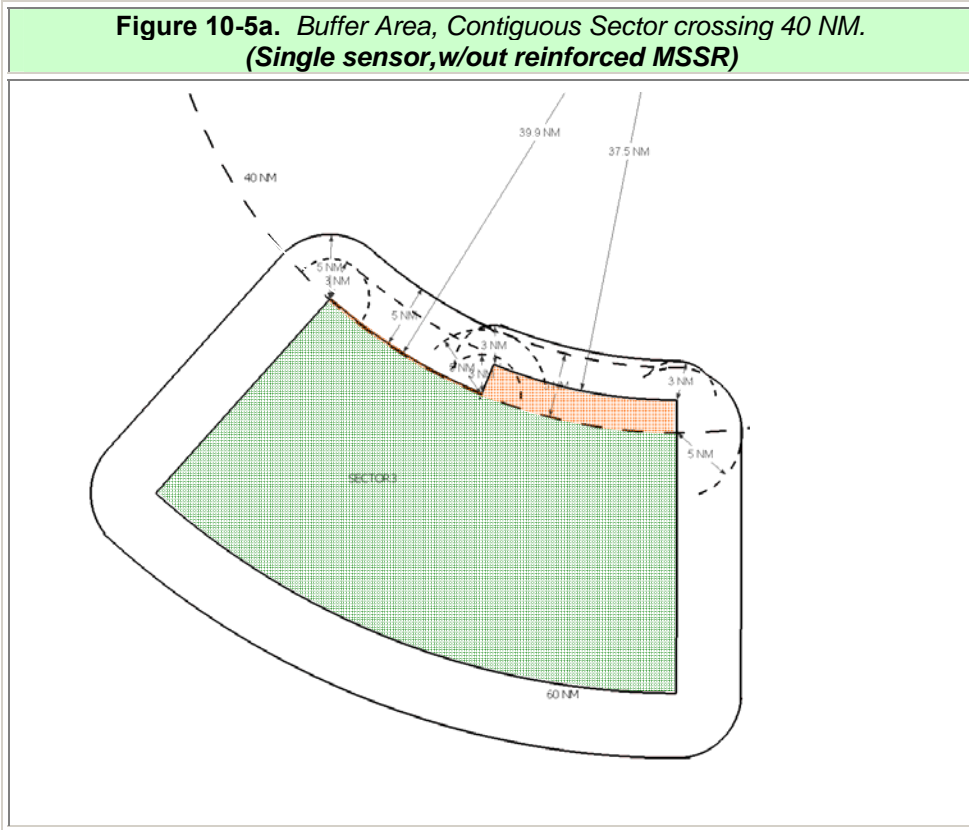

- 10.2.4 a. (2) Multi-sensor adaptation. The OEA includes a buffer extending at least 5 NM outward from the boundary, regardless of distance to radar antenna or MVAC center. See figure 10-6.

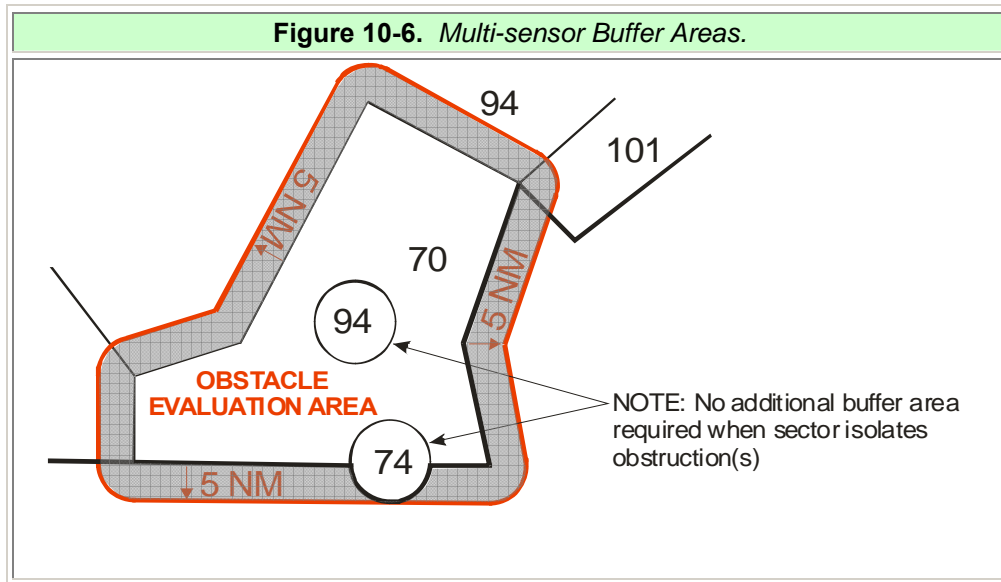

- 10.2.4 b. Isolating Obstacles.** Any obstacle may be isolated to *lower* the MVA in one or more standard sectors. The OEA buffers of neighboring sectors still apply in the isolation area, but *exclude* the specific feature being isolated (i.e., all other obstacles must be considered). Truncate an isolation area at the sector boundary when it expands into a sector requiring a higher MVA. The dimensions of the isolation area otherwise depends on the feature type and whether single or multi-sensor adaptation applies.
- 10.2.4 b. (1) Point Feature (antennas, towers, high-rise buildings, etc). The isolation area is based on a radius centered on the feature that provides at least the minimum lateral clearance applicable to the radar adaptation (*TERPS*, Volume 1, chapter 10, paragraph 10.0.2). Order 8260.19 chapter 2, Section 11 applies. Isolation areas for multiple point features (i.e., antenna or wind farms) may be combined, however the minimum required lateral clearance must be provided from each feature and the MVA must equal the highest required for any individual feature.
- 10.2.4 b. (1) (a) Single-sensor adaptations. The isolation area boundary is a 3 NM radius when the feature is #35 NM or less from the radar antenna, and a 5 NM radius when the feature is more than #35 NM from the radar antenna. *See figure 10-7*. When operationally advantageous, the boundary may be reduced to less than 5 NM for those portions of the isolation area within *40 NM from the antenna, but not less than the minimum required lateral clearance. *See Figure 10-7a*.
- #55 NM for approved full time reinforced MSSR systems.*
- *60 NM for approved full time reinforced MSSR systems.*
- 10.2.4 b. (1) (b) Multi-sensor adaptations. Isolation area boundary is a 5 NM radius, regardless of distance from radar antenna.

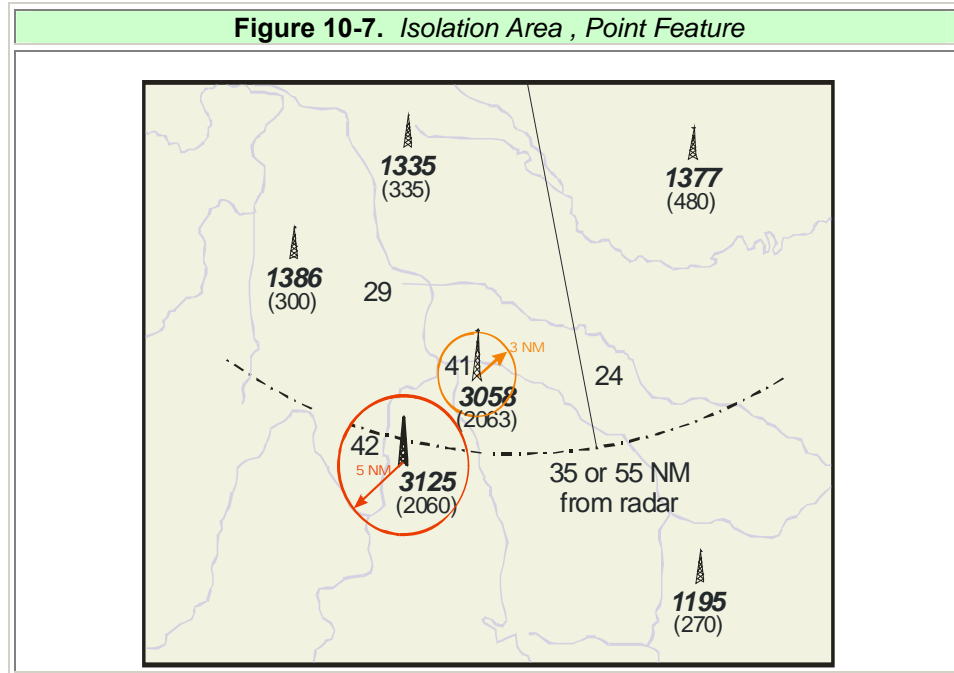

- 10.2.4 b. (2) Zone Feature (e.g., distinct terrain, topographical contours, etc.). When determining the sector boundary first define the dimensions of the feature to be isolated (e.g., mountain from 4,700 ft contour and above).
- 10.2.4 b. (2) (a) Single-sensor adaptations. Establish the isolation area boundary 3 NM from the feature for points 35 NM or less from the radar antenna, and 5 NM from the feature for points more than 35 NM from the radar antenna. When operationally advantageous, the boundary may be reduced to less than 5 NM for those portions of the isolation area within 40 NM from the antenna, but not less than the minimum required lateral clearance. *See Figures 10-8 and 10-8a.*
- 10.2.4 b. (2) (b) Multi-sensor adaptations. Isolation area boundary is a 5 NM from the feature, regardless of distance from radar antenna.

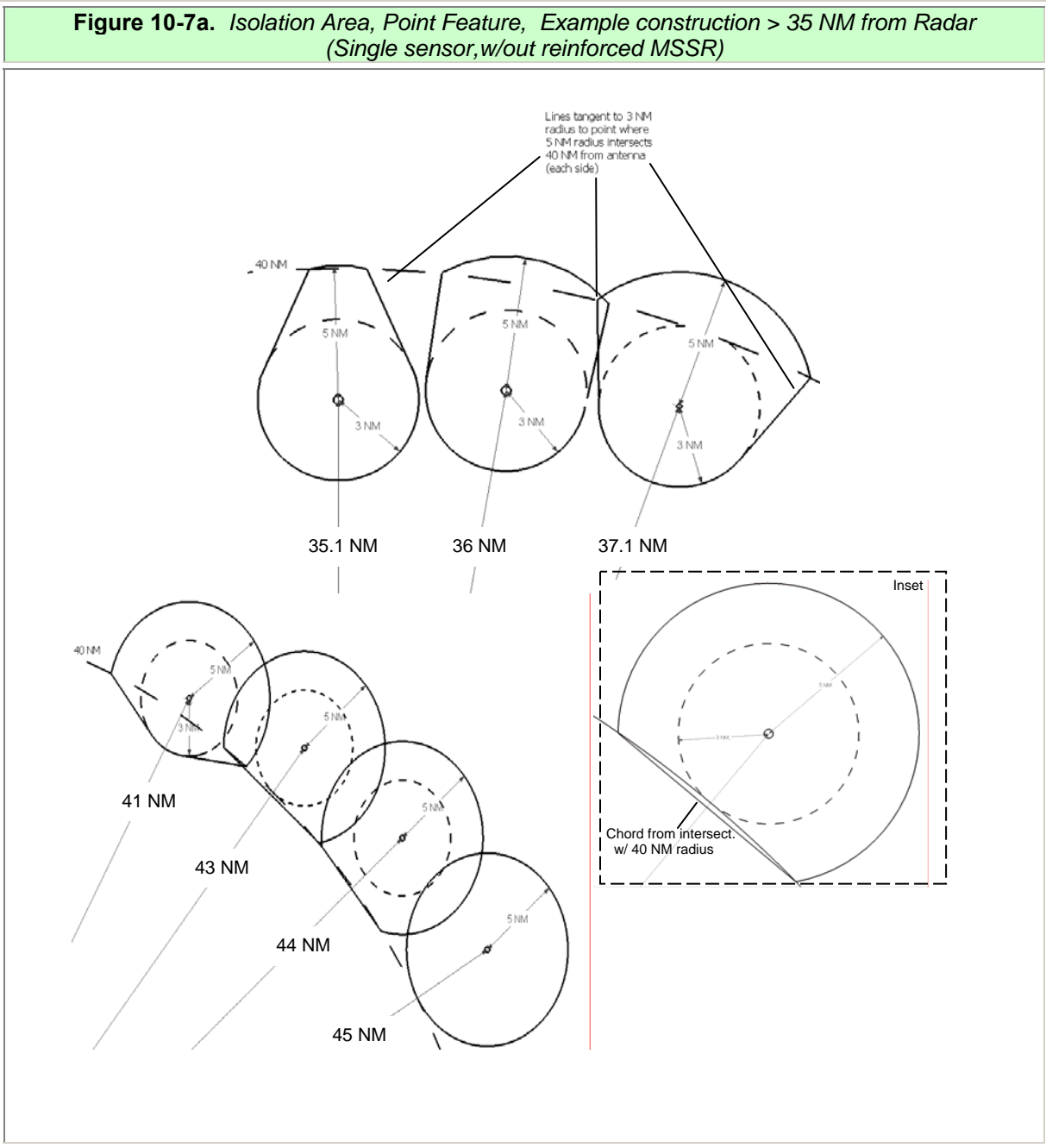

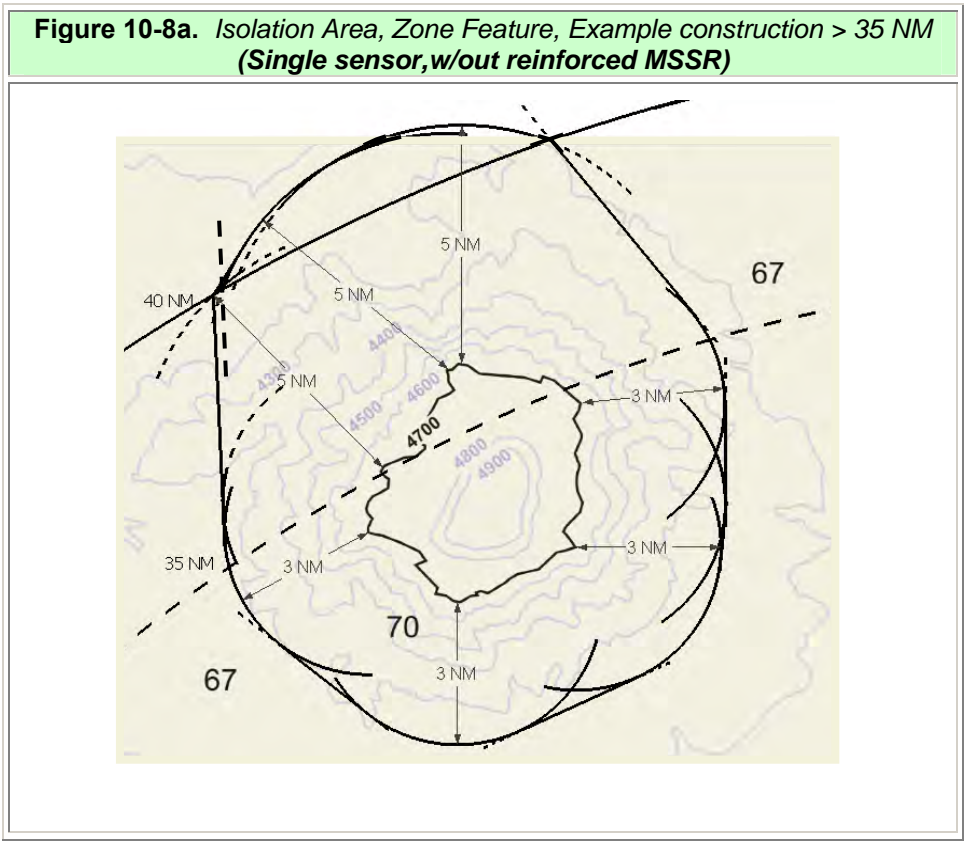
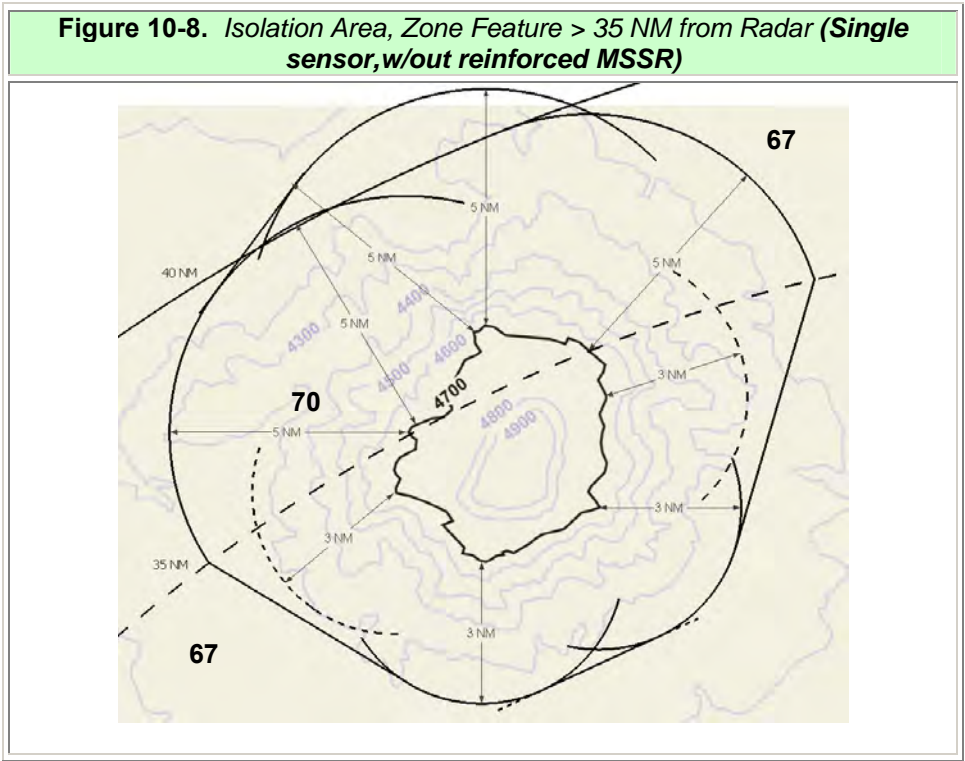

- 10.2.5 Obstacle Clearance.** Required obstacle clearance depends on the radar adaptation and the relationship of the obstacle to those areas designated mountainous per 14 CFR Part 95 Subpart B.
- 10.2.5 a. Non-mountainous terrain.** Apply 1,000 ft ROC over obstacles in non-mountainous areas.
- 10.2.5 b. Mountainous terrain.** Apply 2,000 ft ROC over obstacles in designated mountainous areas. ROC may only be reduced when a reduction has been requested, approved, and documented in accordance with current Order 7210.3, *ATC Facility Operation and Administration* standards (to include associated Notices). Standard reduced ROC values are:
- 10.2.5 b. (1) Single sensor adaptation: Not less than 1,000 ft.
- 10.2.5 b. (2) Multi-sensor adaptation:
- 10.2.5 b. (2) a. Terrain. Not less than 1,500 ft (designated mountainous areas of the Eastern United States, Commonwealth of Puerto Rico, and Hawaii) or 1,700 ft (designated mountainous areas of the Western United States and Alaska).
- 10.2.5 b. (2) b. Man-made obstacles. Not less than 1,000 ft over the obstacle, but the MVA must also provide the minimum required 1,500/1,700 ROC over the terrain underlying the man-made structure.
- 10.2.5 c. When a sector/buffer/isolation area overlies** both non-mountainous and mountainous terrain, consider revising sector boundaries. Otherwise, apply the appropriate ROC based on the location of the obstacle. See figure 10-9.
- 10.2.6 Adverse Assumption Obstacle (AAO) considerations.** (USAF N/A). Apply AAO to terrain except those areas around primary/satellite airports exempted by Order 8260.19 and/or when applying 2,000 unreduced ROC.

Figure 10-9. Sector/Buffer Overlaying Both Mountainous and Non-Mountainous Areas

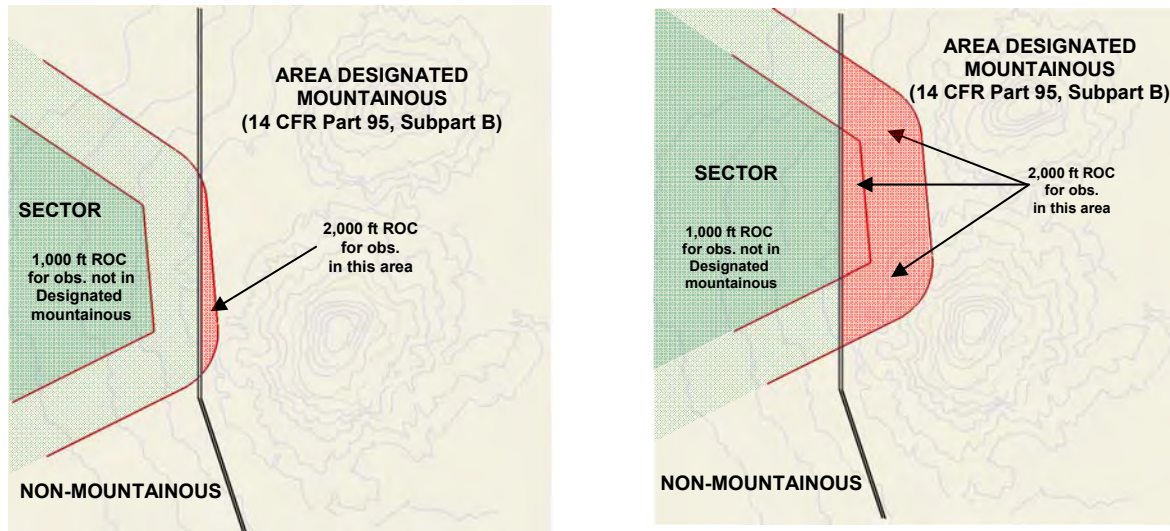

10.2.7 **Airspace.** Establish sector altitudes (to include isolation areas) to provide at least a 300-ft buffer above the floor of controlled airspace. When operationally required, altitudes may be reduced not lower than the floor of controlled airspace.

When consideration of floor of controlled airspace results in an exceptionally high altitude; e.g., in areas where the floor of controlled airspace is 14,500 MSL and operationally required to vector aircraft in underlying Class G (uncontrolled) airspace, two sector altitudes may be established. The first must be based on obstacle clearance and the floor of controlled airspace. A second lower altitude that provides obstacle clearance only may be established. The obstacle clearance only altitude must be uniquely identified; e.g., by an asterisk (*). Do not consider sector buffer areas for controlled airspace evaluations.

10.2.8 **Altitude Selection.** Specify sector altitudes (to include isolation areas) in the 100-ft increment that provides ROC over all obstacle(s) in the OEA.

10.2.8 **a. (USAF N/A).** Sector altitudes may be rounded to the nearest 100-ft increment over AAO obstacles when operationally required.

10.2.8 **b. (USAF and USN N/A).** For non-AAO obstacles, sector altitudes may be rounded to the nearest 100-ft where the entire sector (excluding buffer) or isolation area is;

10.2.8 **b. (1)** In the contiguous United States (not authorized in Alaska, Hawaii, or any other territory or possession) and documented to be within 65 nautical miles (NM) of an altimeter setting source which is issued by Air Traffic Control in accordance with Order JO 7110.65 chapter 2, section 7 and either;

- 10.2.8 b. (1) a. Outside of any area designated mountainous by 14 CFR Part 95, or;
- 10.2.8 b. (1) b. In an area designated mountainous where required obstacle clearance (ROC) is not reduced, or;
- 10.2.8 b. (1) c. In an area designated mountainous where for this purpose the terrain is considered not to be precipitous (i.e. no significant elevation changes greater than 1,500 feet) and at least 951 ft ROC is provided or;
- 10.2.8 b. (1) d. In an area designated mountainous where rounding provides ROC in accordance with table 10-1. Interpolation of this table permitted.

**Table 10-1. Minimum Obstacle Clearance (ft)
Based on ACT/distance from Altimeter Source.**

ACT (°C/°F)	Distance ≤ 65 NM
-40/-40	1851
-30/-22	1651
-20/-4	1451
-10/14	1251
0/32	1051
2/36	1051*
7/45	951

* 951 within 35 NM

Example: The ACT is determined to be -30°C. The controlling obstacle is a 2,549 MSL tower, and ROC is reduced to 1,800 ft. The minimum sector altitude may be rounded to 4,300 since it provides at least 1,651 ft clearance.

THIS PAGE IS INTENTIONALLY LEFT BLANK

*Order 8260.3B, Volume 1, Chapter 10
Formulas Addendum*

Formula 10-1. Final Area Half-Width at PFAF and RWT/FEP (Hw).		
$H_W = 0.1 \cdot D + 1$		
<i>where</i> <i>D = Distance, FAC point to Antenna (NM)</i> <i>(HW = 3 NM where D > 20 NM)</i>		
$0.1 \cdot D + 1$		
Calculator		
<i>D</i>		Click here to calculate
<i>Hw</i>		
Back		

Formula 10-2. Recommended Altitudes (RecAlt).		
$RecAlt = A - DG$		
<i>where</i> <i>A = PFAF altitude or Last RecAlt (unrounded)</i> <i>DG = (1852/0.3048) x tan [VDA calculated per Vol. 1, Chap. 2, para 252]</i>		
$A - DG$		
Calculator		
<i>A</i>		Click here to Calculate
<i>DG</i>		
<i>RecAlt</i>		
Back		

THIS PAGE INTENTIONALLY LEFT BLANK

CHAPTER 11. HELICOPTER PROCEDURES TIL00-0016

Section 1. Administrative

1100. GENERAL. This chapter contains criteria for application to “helicopter only” procedures. These criteria are based on the premise that helicopters are classified in approach Category A and are capable of special maneuvering characteristics. The intent, therefore, is to provide relief from those portions of other TERPS chapters that are more restrictive than the criteria specified herein. However, any criteria contained elsewhere in other chapters of this document may be applied to helicopter only procedures when an operational advantage may be gained.

a. Identification of Inapplicable Criteria. Criteria contained elsewhere in this document normally apply to helicopter procedures. Where this chapter changes such criteria, the changed material is identified. Circling approach and high altitude penetration criteria do not apply to helicopter procedures.

b. Use of Existing Facilities. Helicopter only procedures based on existing facilities may be developed using criteria contained in this chapter.

1101. TERMINOLOGY. The following terms are peculiar to helicopter procedures and are defined as follows:

a. Height Above Landing (HAL) is the height above landing area elevation.

b. Height Above the Surface (HAS) is the height of the MDA above the highest terrain/surface within a 5,200-foot radius of the MAP in point in space procedures.

c. Landing Area as used in helicopter operations refers to the portion of the heliport or airport runway used, or intended to be used for the landing and takeoff of helicopters.

d. Landing Area Boundary (LAB) is the beginning of the landing area of the heliport or runway.

e. Point in Space Approach is an instrument approach procedure to a point in space, identified as a missed approach point, which is not associated with a specific landing area within 2,600 feet of the MAP.

f. Touchdown zone, as used in helicopter procedures, is identical to the landing area.

1102. DELETED.

1103. TYPE OF PROCEDURE. HELICOPTER ONLY PROCEDURES are designed to meet low altitude straight-in requirements ONLY.

1104. FACILITIES FOR WHICH CRITERIA ARE NOT PROVIDED. This chapter does not include criteria for procedures predicated on VHF/UHF DF, area navigation (RNAV), airborne radar approach (ARA), or microwave landing system (MLS). Procedures using VHF/UHF DF may be developed in accordance with the appropriate chapters of this document.

1105. PROCEDURE IDENTIFICATION. Identify helicopter-only procedures using the term “COPTER,” the type of facility or system providing final approach course guidance, and:

a. For Approaches to Runways. The abbreviation RWY, and the runway number; e.g., COPTER ILS or LOC RWY 17; COPTER RNAV (GPS) RWY 31.

b. For Approaches to Heliports and a Point-in-Space. The magnetic final approach course value and degree symbol; e.g., COPTER ILS or LOC 014°; COPTER TACAN 097°, COPTER RNAV (GPS) 010°.

c. For Approaches Based on an ARC Final. The word ARC will be used, and will be followed by a sequential number; e.g., COPTER VOR/DME ARC 1.

d. For separate procedures at the same location. Use the same type of facility and same final approach course, add an alpha suffix starting in reverse alphabetical order; COPTER ILS or LOC Z RWY 28L (first procedure), COPTER ILS or LOC Y RWY 28L (second procedure), COPTER ILS or LOC X RWY 28L (third procedure), etc.

Section 2. General Criteria

1106. APPLICATION. These criteria are based on the unique maneuvering capability of the helicopter at airspeeds not exceeding 90 knots.

1107. POINT IN SPACE APPROACH. Where the center of the landing area is not within 2,600 feet of the MAP, an approach procedure to a point in space may be developed using any of the facilities for which criteria are provided in this chapter. In such procedures the point in space and the missed approach point are identical and upon arrival at this point, helicopters must proceed under visual flight rules (or special VFR in control zone as applicable) to a landing area or conduct the specified missed approach procedure. The published procedure shall be noted to this effect and also should identify available landing areas in the vicinity by noting the course and distance from the MAP to each selected landing area. Point in space approach procedures will not contain alternate minima.

1108. APPROACH CATEGORIES. When helicopters use instrument flight procedures designed for fixed wing aircraft, approach Category "A" approach minima shall apply regardless of helicopter weight.

1109. PROCEDURE CONSTRUCTION. Paragraph 214 applies except for the reference to circling approach.

1110. DESCENT GRADIENT. The descent gradient criteria specified in other chapters of this document do not apply. The optimum descent gradient in *all* segments of helicopter approach procedures is 400 feet per mile. Where a higher descent gradient is necessary, the recommended maximum is 600 feet per mile. However, where an operational requirement exists, a gradient of as much as 800 feet per mile may be authorized, provided the gradient used is depicted on approach charts. See special procedure turn criteria in paragraph 1112.

1111. INITIAL APPROACH SEGMENTS BASED ON STRAIGHT COURSES AND ARCS WITH POSITIVE COURSE GUIDANCE. Paragraph 232 is changed as follows:

a. Alignment.

(1) **Courses.** The 2-mile lead radial specified in paragraph 232a(1) is reduced to 1 mile. See Figure 3.

(2) **Arcs.** The minimum arc radius specified in paragraph 232a(2) is reduced to 4 miles. The 2-mile lead radial may be reduced to 1 mile. See Figure 10.

1112. INITIAL APPROACH BASED ON PROCEDURE TURN. Paragraph 234 applies except for all of subparagraph d and the number 300 in subparagraph e(1) which is changed to 600. Since helicopters operate at approach Category A speeds the 5-mile procedure turn will normally be used. However, the larger 10- and 15-mile areas may be used if considered necessary.

a. Descent Gradient. Because the actual length of the track will vary with environmental conditions and pilot technique, it is not practical to specify a descent gradient solely in feet per mile for the procedure turn. Instead, the descent gradient is controlled by requiring the procedure turn completion altitude to be as close as possible to the final approach fix altitude. The difference between the procedure turn completion altitude and the altitude over the final approach fix shall not be greater than those shown in Table 23.

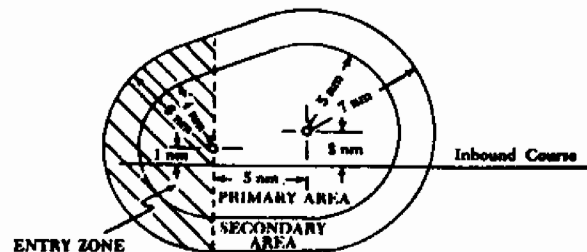

Figure 105. HELICOPTER PROCEDURE TURN AREA.
Par 1112.

Table 23. PROCEDURE TURN COMPLETION ALTITUDE DIFFERENCE. Par 1112.

Type Procedure Turn	Altitude Difference
15 mile PT from FAF	Within 6000 ft of alt over FAF
10 mile PT from FAF	Within 4000 ft of alt over FAF
5 mile PT from FAF	Within 2000 ft of alt over FAF
15 mile PT, no FAF	Not Authorized
10 mile PT, no FAF	Within 4000 ft of MDA on Final
5 mile PT, no FAF	Within 2000 ft of MDA on Final

1113. INTERMEDIATE APPROACH SEGMENT BASED ON STRAIGHT COURSES. Paragraph 242 is changed as follows:

a. Alignment. The provisions of paragraph 242a apply with the exception that the intermediate course shall not differ from the final approach course by more than 60 degrees.

b. Area.

(1) **Length.** The OPTIMUM length of the intermediate approach segment is 2 miles. The minimum length is 1 mile and the recommended maximum is 5 miles. A distance greater than 5 miles should not be used unless an operational requirement justifies the greater distance. When the angle at which the initial approach course joins the intermediate course exceeds 30 degrees (see figure 3), the MINIMUM length of the intermediate course is as shown in table 24.

1114. INTERMEDIATE APPROACH SEGMENT BASED ON AN ARC. Paragraph 243 is changed as follows: Arcs with a radius of less than 4 miles or more than 30 miles from the navigation facility shall not be used.

a. Area.

(1) **Length.** The OPTIMUM length of the intermediate approach segment is 2 miles. The minimum length is 1 mile and the recommended maximum is 5 miles. A distance greater than 5 miles should not be used unless an operational requirement justifies the greater distance. When the angle at which the initial approach course joins the intermediate course

Table 24. MINIMUM INTERMEDIATE COURSE LENGTH
(Not applicable to PAR and ILS)

ANGLE (degrees)	MINIMUM LENGTH (miles)
30	1.0
60	2.0
90	3.0
120	4.0

Note: This table may be interpolated.

exceeds 30 degrees (see figure 3), the MINIMUM length of the intermediate course is as shown in table 24.

1115. INTERMEDIATE SEGMENT WITHIN A PROCEDURE TURN SEGMENT. Paragraph 244b is changed as follows: The normal procedure turn distance is 5 miles from the fix or from the facility. This produces an intermediate segment 5 miles long. The portion of the intermediate segment considered for obstacle clearance will always have the same length as the procedure turn distance. A distance greater than 5 miles should not be used unless an operational requirement justifies the greater distance. See figure 13, paragraph 244.

1116. FINAL APPROACH. Paragraph 250 applies except that the word runway is understood to include landing area and the reference to circling approach does not apply. The final approach course in precision approach procedures shall be aligned as indicated in paragraphs 1152 and 1159. For nonprecision procedures final approach course alignment shall be as follows:

a. Approaches to a Landing Area. The final approach course should be aligned so as to pass through the landing area. Where an operational advantage can be achieved, a final approach course which does not pass through the landing area may be established, provided such a course lies within 2600 feet of the center of the landing area at the MAP.

b. Point-in-Space Approaches. The final approach course should be aligned to provide for the most effective operational use of the procedure consistent with safety.

1117. MISSED APPROACH POINT. Paragraph 272 is changed to state that the specified distance may not be more than the distance from the final approach fix to a point not more than 2600 feet from the center of the landing area. The MAP may be located more than 2600 feet from the landing area, provided the minimum visibility agrees with the increased distance; e.g., MAP 3800 feet from landing area, basic visibility is 3/4 mile. See figure 108. For point-in-space approaches the MAP is on the final approach course at the end of the final approach area.

1118. STRAIGHT MISSED APPROACH AREA. Paragraph 273 applies with the exception that the length of the primary and secondary missed approach area is

reduced from 15 miles to 7.5 miles and will have the width of the appropriate airway at termination.

1119. STRAIGHT MISSED APPROACH OBSTACLE CLEARANCE. Paragraph 274 applies except that "TDZ or airport elevation" is changed to "landing area elevation;" the slope of the missed approach surface is changed from 40:1 to 20:1; and the secondary area slope is changed from 12:1 to 4:1.

1120. TURNING MISSED APPROACH AREA. The provisions of paragraph 275 apply with the exception that when applying missed approach criteria shown in figures 19 through 24, and table 5, change all flight path lengths to 7.5 miles, missed approach surface slope to 20:1, secondary slopes to 4:1, obstacle clearance radius (R) to 1.3 miles, and flight path radius (R₁) to 4000 feet (.66 miles). The area width will expand uniformly to the appropriate airway width.

1121. TURNING MISSED APPROACH OBSTACLE CLEARANCE. All missed approach areas described in paragraph 276 and depicted in figures 25 and 26 will be adjusted for helicopter operation using the values shown in paragraph 1120. The area width will expand uniformly to the appropriate airway width.

1122. COMBINATION STRAIGHT AND TURNING MISSED APPROACH. Paragraph 277 applies except that the values shown in paragraph 1120 shall be used, and point B is relocated to a position abeam the MAP. The area width will expand uniformly to the appropriate airway width. See figure 106.

1123. HOLDING ALIGNMENT. The provisions of paragraph 291 apply with the exception when the final approach fix is a facility, the inbound holding course shall not differ from the final approach course by more than 90 degrees.

1124. HOLDING AREA. Paragraph 292 applies except that the minimum size pattern is No.1.

**Section 3. Takeoff and Landing
Minimums**

1125. APPLICATION. The minimums specified in this section apply to Helicopter Only procedures.

1126. ALTITUDES. Chapter 3, section 2, is changed as follows:

a. In paragraph 320 "runway environment" is understood also to mean "landing area environment."

b. In paragraph 321 reference to 40:1 is changed to 20:1.

c. Paragraph 322 does not apply.

d. Paragraphs 324, 938 and 1028 apply except that a DH of 100 feet may be approved without approach lights; the tables in paragraph 350 do not apply, and table 29 in paragraph 1167 governs the establishment of the DH.

1127. VISIBILITY. Chapter 3, section 3, is changed as follows:

* a. *Nonprecision Approaches.*

(1) **Approach to Runway.** The minimum visibility may be 1/2 the computed straight-in CAT A fixed-wing value from tables 6, 9, or 10, as applicable, but not less than 1/4 mile/1,200 RVR.

(2) **Approach to Landing Area.** (Landing area within 2600 feet of MAP). The minimum visibility required prior to applying credit for lights may not be less than the visibility associated with the HAL, as specified in table 25. Paragraphs 330 and 331 do not apply.

b. *Precision Approaches.*

(1) **Approach to Runway.** The minimum visibility may be 1/2 the computed straight-in CAT A fixed-wing values specified in tables 9 and 10, but not less than 1/4 mile/1200 RVR.

(2) **Approach to Landing Area.** The minimum visibility authorized prior to applying credit for lights is 1/2 mile/2400 RVR. Paragraphs 330 and 331 do not apply.

* c. *Point-in-Space Approaches.* The minimum visibility prior to applying credit for lights is 3/4 mile. If the HAS exceeds 800 feet, the minimum no-lights visibility shall be 1 mile. No credit for lights will be authorized unless an approved visual lights guidance system is provided. See also paragraph 344. Alternate minimums are not authorized. Table 25 does not apply.

Policy
Memo
Dec 28
2007

*

*

Policy
Memo
Dec 28
2007

EXAMPLE

MDA is 360' MSL based on obstacles in the approach area. A 1098' MSL controlling obstacle is 1 mile (6076') from the near edge of Section 1.

A 20:1 surface which clears the obstacle has a height of 794' MSL at the near edge of Section 1.

6076 Divided by 20 Equals 304 1098 Minus 304 Equals 794.

To determine minimum altitude at which the missed approach aircraft may start the turn add 250' obstacle clearance and round up the sum to the next higher 20' increment.

794' Plus 250' Equals 1044' rounded up Equals 1060' MSL.

To climb 700' from MDA 360' MSL to the turning altitude (1060' MSL) at the 20:1 climb gradient requires 14,000'. This is the minimum length of Section 1.

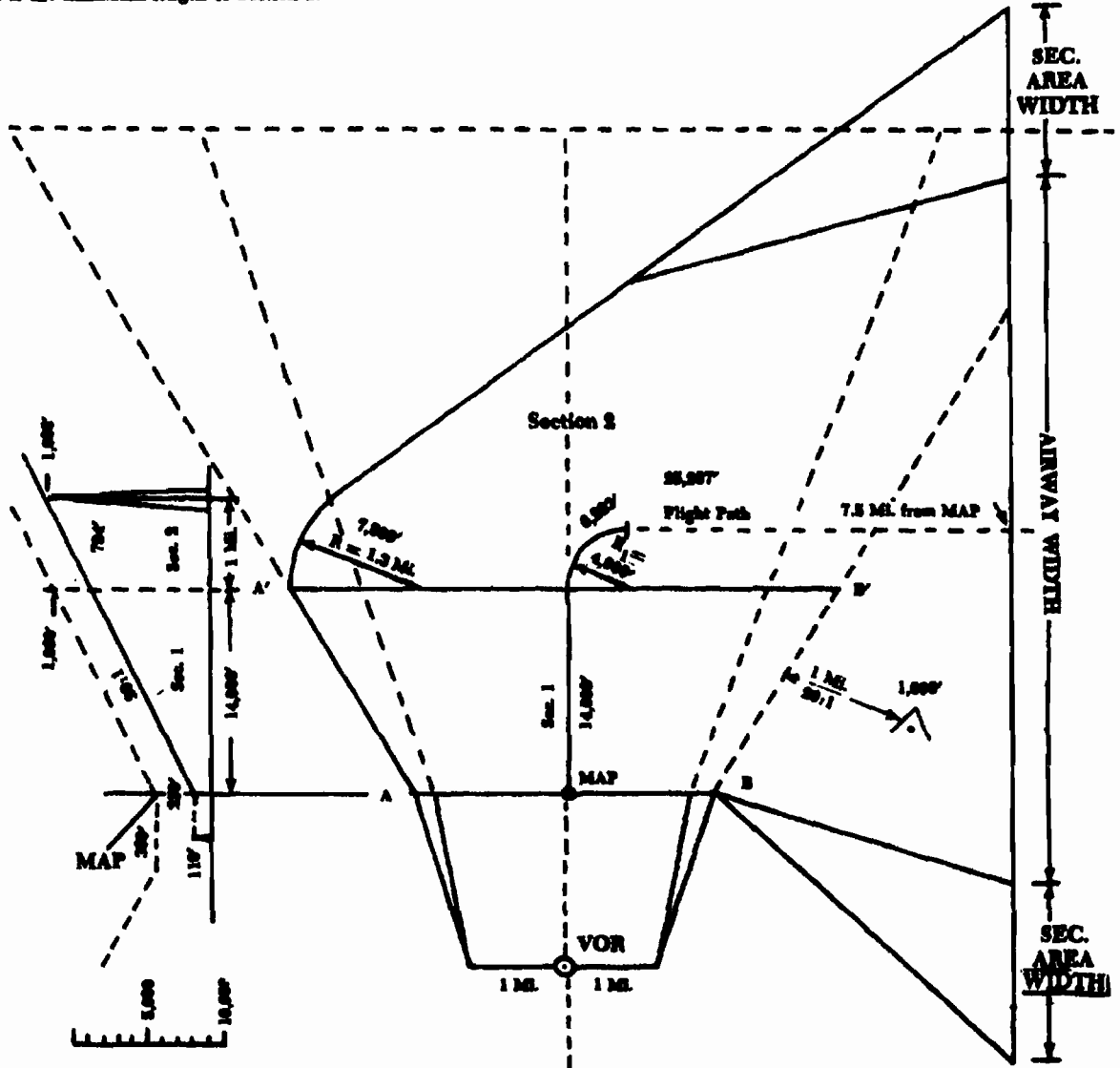

Figure 106. COMBINATION MISSED APPROACH AREA. Paragraph 1122.

Policy
Memo
Dec 28
2007

* **1128. VISIBILITY CREDIT.** Where visibility credit for lighting facilities is allowed for fixed-wing operations, the same type credit should be considered for helicopter operations. The approving authority will grant credit on an individual case basis, until such time

as a standard for helicopter approach lighting systems is established. The concepts stated in paragraph 342 apply, except heliport markings may be substituted for the runway marking requirements specified therein.

*

Table 25. EFFECT OF HAL HEIGHT ON VISIBILITY MINIMUMS. Par 1127a

HAL	250-600 ft.	601-800 ft.	More than 800 ft.
Visibility Minimum (Mi)	1/2	3/4	1

* * *

Policy Memo Dec 28 2007

1129. TAKEOFF MINIMUMS. Paragraph 370 does not apply. Helicopter takeoff minimums will be in accordance with the appropriate Federal Aviation Regulations and Military Regulations.

Section 4. On-Heliport VOR (No FAF)

1130. GENERAL. Paragraph 400 does not apply. These criteria apply to procedures based on a VOR facility located within 2600 feet of the center of the landing area in which no final approach fix is established. These procedures must incorporate a procedure turn.

1131. INITIAL AND INTERMEDIATE SEGMENTS. These criteria are contained in section 2 of this chapter.

1132. FINAL APPROACH SEGMENT. Paragraph 413 does not apply, except as noted below. The final approach begins where the procedure turn intersects the final approach course inbound.

a. Alignment. Paragraph 1116a applies.

b. Area. The primary area is longitudinally centered on the final approach course. The MINIMUM length is 5 miles. This may be extended if an operational requirement exists. The primary area is 2 miles wide at the facility and expands uniformly to 4 miles wide at 5 miles from the facility. A secondary area is on each side of the primary area. It is zero miles wide at the facility and expands uniformly to .67 mile on each side of the primary area at 5 miles from the facility. See figure 107.

c. Obstacle Clearance. Paragraph 413c(1) applies.

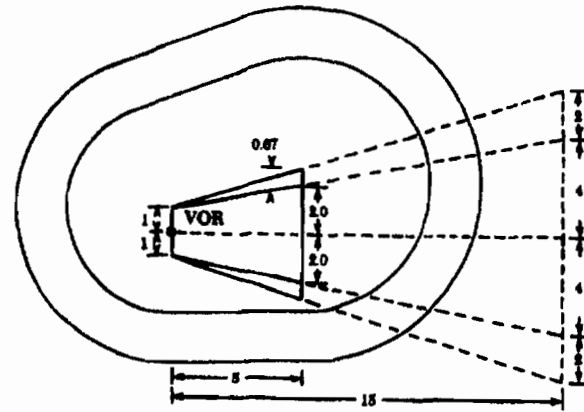

Figure 107. FINAL APPROACH PRIMARY AND SECONDARY AREA. On-Heliport VOR, No FAF, Par 1132b. See also Figure 105.

d. Procedure Turn Altitude. The procedure turn completion altitude shall be in accordance with table 23.

e. Use of Stepdown Fix. Paragraph 413e applies, except that 4 miles is changed to 2.5 miles.

f. Minimum Descent Altitude. Criteria for determining MDA are contained in section 3 of this chapter and chapter 3.

Section 5. TACAN, VOR/DME, and VOR with FAF

1133. FINAL APPROACH SEGMENT. Paragraph 513 does not apply, except as noted below.

a. Alignment. Paragraphs 1116a and b apply.

b. Area. Paragraph 513b applies, except that portion which refers to the minimum length of the final approach segment. The minimum length of the final approach segment is shown in table 26.

Table 26. MINIMUM LENGTH OF FINAL APPROACH SEGMENT (MILES)

Magnitude of Turn Over the Facility		
30°	60°	90°
1.0	2.0	3.0

NOTE: This table may be interpolated.

c. *Obstacle Clearance.* Paragraph 513.c.(1) applies.

1134. RESERVED

1135. MISSED APPROACH POINT. The identification of the MAP in Paragraph 514 is changed as follows: The missed approach point is a point on the final approach course which is not farther than 2600 feet from the center of the landing area. See Figure 108. For point in space approaches the MAP is on the final approach course at the end of the final approach area.

1136. ARC FINAL APPROACH SEGMENT RADIUS. Paragraph 523.b. does not apply. The final approach arc shall be a continuation of the intermediate arc. It shall be specified in nautical miles and tenths thereof. The minimum arc radius on final approach is 4 miles.

1137. ARC FINAL APPROACH SEGMENT ALIGNMENT. Paragraph 523.b.(1) does not apply. The final approach arc should be aligned so as to pass through the landing area. Where an operational advantage can be achieved, a final approach course which does not pass through the landing area may be established provided the arc lies within 2600 ft. of the landing area at the MAP.

1138. RESERVED.

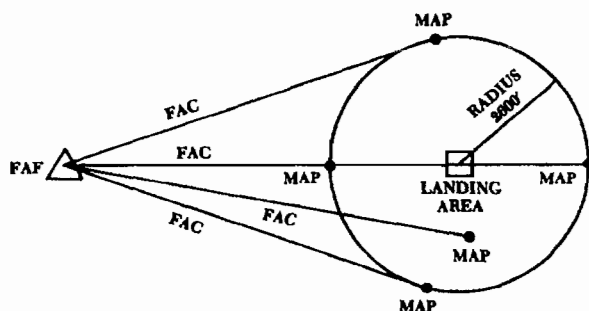

MISSED APPROACH POINT OPTIONS

Figure 108. MISSED APPROACH POINTS. Off-Heliport VOR with FAF. Par. 1135.

Section 6. ON-HELIPORT NDB, No FAF

1139. GENERAL. Paragraph 600 does not apply. These criteria apply to procedures based on an NDB facility located within 2600 feet of the center of the

landing area in which no final approach fix is established. These procedures must incorporate a procedure turn.

1140. FINAL APPROACH SEGMENT. Paragraph 613 does not apply except as noted below. The final approach begins where the procedure turn intersects the final approach course, inbound.

a. *Alignment.* Paragraph 1116.a. applies.

b. *Area.* The primary area is longitudinally centered on the final approach course. The MINIMUM length is 5 miles. This may be extended if an operational requirement exists. The primary area is 2.5 miles wide at the facility, and expands uniformly to 4.25 miles wide at 5 miles from the facility. A secondary area is on each side of the primary area. It is zero miles wide at the facility, and expands uniformly to .67 miles wide on each side of the primary area at 5 miles from the facility. Figure 109 illustrates the primary and secondary areas.

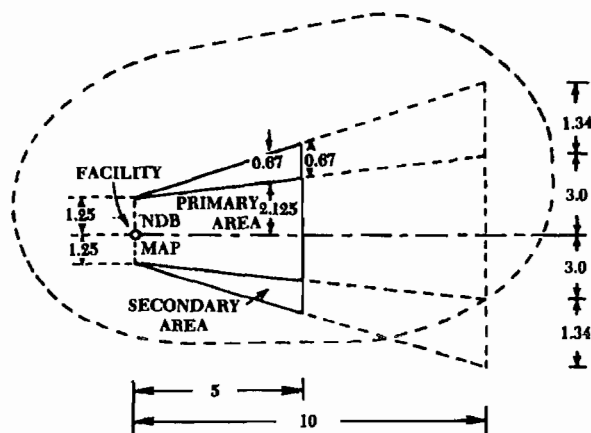

Figure 109. FINAL APPROACH PRIMARY AND SECONDARY AREAS. On-Heliport NDB. No FAF. Paragraph 1140.

c. *Obstacle Clearance.* Paragraph 613.c.(1) applies.

d. *Procedure Turn Altitude (Descent Gradient).* The procedure turn completion altitude shall be in accordance with Table 23.

e. *Use of Stepdown Fix.* Paragraph 613.e. applies except that 4 miles is changed to 2.5 miles.

f. *Minimum Descent Altitude.* Criteria for determining the MDA are contained in Section 3 of this chapter and Chapter 3.

Section 7. NDB Procedures with FAF

1141. GENERAL. These criteria apply to procedures based on an NDB facility which incorporates a final approach fix.

1142. FINAL APPROACH SEGMENT. Paragraph 713 does not apply except as noted below:

a. Alignment. Paragraphs 1116.a. and b. apply.

b. Area. Paragraph 713.b. applies except that portion which refers to the minimum length of the final approach segment. The minimum length is specified in Table 26.

c. Obstacle Clearance. Paragraph 713.c.(1) applies.

1143. MISSED APPROACH POINT. The identification of the MAP in Paragraph 714 is changed as follows: The missed approach point is a point on the final approach course which is not farther than 2600 feet from the center of the landing area. See Figure 108. For point in space approaches, the MAP is on the final approach course at the end of the final approach area.

Section 8. RESERVED.

1144. – 1149. RESERVED.

Section 9. ILS Procedures

1150. GENERAL. Chapter 9 is changed as noted in this section. These criteria apply to the present design of instrument landing systems (on airport) only.

1151. INTERMEDIATE APPROACH SEGMENT. Paragraph 922 applies with the exception that Table 27 specifies the minimum length of the intermediate segment based on the angle of intersection of the initial approach course with the localizer course.

1152. FINAL APPROACH SEGMENT. Paragraph 930 applies except that glide slope intercep-

tion need not occur prior to the FAF normally used for fixed wing operations.

a. The optimum length of the final approach course is 3.0 miles. The minimum length is 2.0 miles. A distance in excess of 4.0 miles should not be used unless a special operational requirement exists.

b. Final Approach Termination. The final approach shall terminate at a landing point (runway) or at a hover point between the Decision Height and the GPI. Where required, visual hover/taxi routes will be provided to the terminal area.

1153. MISSED APPROACH AREA. Normally existing missed approach criteria will be utilized for helicopter operations. However, if an operational advantage can be gained, the areas described in Paragraphs 1168 through 1171 may be substituted.

1154. MICROWAVE ILS. Additional criteria will be developed to exploit the capabilities of the microwave ILS which is now under development. It is expected that this new equipment will provide glide slope angles in the range from 3 to 12 degrees and the flexibility to satisfy special aircraft and ground siting requirements.

1155. LOCALIZER AND LDA. Section 5 of Chapter 9 is changed as noted in this paragraph.

a. Alignment. Paragraph 952 applies except that LDA alignment shall be as specified in paragraphs 1116.a. and b.

b. Area. Paragraph 953 applies except that portion which refers to the minimum length of the final approach segment. The minimum length of the final approach segment is shown in Table 26.

c. Missed Approach Point. The identification of the MAP in Paragraph 957 is changed as follows: The missed approach point is a point on the final approach course which is not farther than 2600 feet from the landing area. See Figure 108. For point-in-space approaches, the MAP is on the final approach course at the end of the final approach area.

Section 10. Precision Approach Radar (PAR)

1156. INTERMEDIATE APPROACH SEGMENT. Paragraph 1014 applies with the exception that Table 27 specifies the minimum length of the intermediate segment based on the angle of intersection of the initial approach course with the intermediate course.

Table 27. INTERMEDIATE SEGMENT ANGLE OF INTERCEPT VS. SEGMENT LENGTH. Paragraph 1156.

Angle (Degrees)	Minimum Length (Miles)
30	1
60	2
90	3

NOTE: This table may be interpolated.

1157. RESERVED.

1158. FINAL APPROACH SEGMENT. The provisions of Paragraph 1020.b.(1) and (2) do not apply. The minimum distance from the glide slope intercept point to the GPI is 2 miles.

1159. FINAL APPROACH ALIGNMENT. Paragraph 1020.a. applies with the exception that a final approach course shall be aligned to a landing area. Where required, visual hover/taxi routes shall be established leading to terminal areas.

1160. FINAL APPROACH AREA.

a. Length. The final approach area is 25,000 feet long, measured outward along the final approach course from the GPI. Where operationally required for other procedural considerations or for existing obstacles, the length may be increased or decreased symmetrically, except when glide slope usability would be impaired or restricted. See Figure 110.

b. Width. The final approach area is centered on the final approach course. The area has a total width of 500 feet at the GPI and expands uniformly to a total width of 8000 ft. at a point 25,000 ft.

outward from the GPI. The widths are further uniformly expanded or reduced where a different length is required as in Paragraph 1160.a. above. See Figure 110. The width either side of the centerline at a given distance "D" from the point of beginning can be found by using the formula $250 + .15D = 1/2$ width.

1161. RESERVED.

1162. FINAL APPROACH OBSTACLE CLEARANCE SURFACE. Paragraph 1021 does not apply. The final approach obstacle clearance surface is divided into two sections.

a. Section 1. This section originates at the GPI and extends for a distance of 775 feet in the direction of the FAF. It is a level plane, the elevation of which is equal to the elevation of the GPI.

b. Section 2. This section originates 775 feet outward from the GPI. It connects with Section 1 at the elevation of the GPI. The gradient of this section varies with the glide path angle used.

(1) To identify the glide slope angle and associated final approach surface gradient to clear obstacles in Section 2:

(a) Determine the distance "D" from the GPI to the controlling obstacle and the height of the controlling obstacle above the GPI.

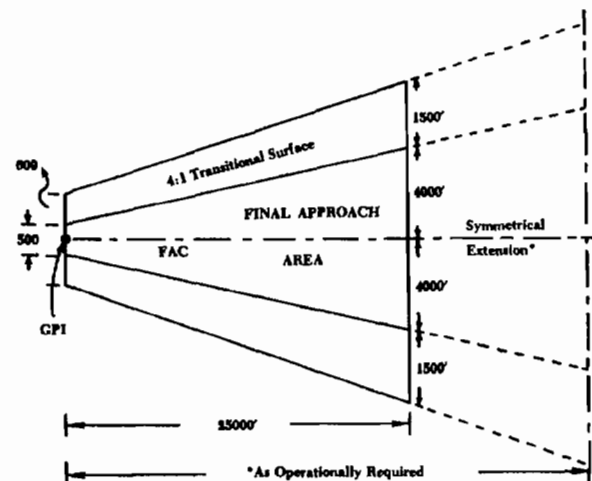

Figure 110. PAR FINAL APPROACH AREA.
Par 1159 and 1160

**Table 28. FINAL APPROACH GLIDE SLOPE – SURFACE SLOPE ANGLES.
Par. 1162.b.**

Glide Slope Angle (Degrees)	Less Than 3	3	4	5	6	7	8	12
Section 2 obstacle clearance surface gradient (degrees)	*	1.65	2.51	3.37	4.23	5.09	5.95	9.39

*NOTE: This table may be interpolated.
* See Par 1165.a.*

(b) Enter these values in the formula:

$$\text{TAN. ANGLE} = \frac{\text{Obstacle height}}{\text{D-775}}$$

(c) Convert the tangent angle. This is the angle of the Section 2 approach surface gradient measured at the height of the GPI.

(d) The minimum glide slope angle required is found in Table 28.

1163. TRANSITIONAL SURFACES. Paragraph 1022 does not apply. Transitional surfaces for PAR are inclined planes with a slope of 4:1 which extend outward and upward from the edges of the final approach surfaces. They start at the height of the applicable final approach surface, and are perpendicular to the final approach course. They extend laterally 600 feet at the GPI and expand uniformly to a width of 1500 feet at 25,000 feet from the GPI.

1164. OBSTACLE CLEARANCE. Paragraph 1024 does not apply. No obstacle should penetrate the applicable final approach surfaces specified in Paragraph 1162 or the transitional surfaces specified in Paragraph 1163. Obstacle clearance requirements greater than 500 feet need not be applied unless required in the interest of safety due to precipitous terrain or radar system peculiarities.

NOTE: The terrain in Section 1 may rise at a gradient of 75:1 without adverse effect on minimums provided the surface is free of obstacles.

1165. GLIDE SLOPE. Required obstacle clearance is specified in Paragraph 1164. In addition, consideration shall be given to the following in the selection of the glide slope angle:

a. If angles less than 3 degrees are established, the obstacle clearance requirements shall be arrived at in accordance with Paragraphs 1024 and 1025.

b. Angles greater than 6 degrees shall not be established without authorization of the approving authority. The angle selected should be no greater than that required to provide obstacle clearance.

c. Angles selected should be increased to the next higher tenth of a degree, e.g., 4.71 degrees becomes 4.8; 4.69 degrees becomes 4.7.

1166. RELOCATION OF THE GLIDE SLOPE. Paragraph 1027 does not apply. The GPI shall normally be located at the arrival edge of the landing area. If obstacle clearance requirements cannot be satisfied, or if other operational advantages will result, the GPI may be moved into the landing area provided sufficient landing area is available forward of the displaced or relocated GPI.

1167. ADJUSTMENT OF DH. An adjustment is required whenever the angle to be used exceeds 3.8 degrees. See Table 29. This adjustment is necessary to provide ample deceleration distance between the DH point and the landing area.

1168. MISSED APPROACH OBSTACLE CLEARANCE. No obstacle may penetrate a 20:1 missed approach surface which overlies the missed

**Table 29. MINIMUM DH – GS ANGLE RELATIONSHIP.
Par. 1167.**

GS Angle (degrees)	up to 3.80	3.81 to 5.70	Over 5.70
Minimum DH (feet)	100	150	200

approach areas illustrated in Figures 113, 114 and 115. The missed approach surface originates at the GPI. However, to gain relief from *existing* obstacles in the missed approach area the point at which the surface originates may be relocated as far backward from the GPI as a point on the final approach course which is directly below the MAP. In such cases the surface originates at a height below the DH as specified in Table 30. See Figure 112.

NOTE: When penetration of the 20:1 surface originating at the GPI occurs, an upward adjustment to the DH equal to the maximum penetration of the surface should be considered.

1169. STRAIGHT MISSED APPROACH AREA. The straight missed approach (maximum of 15 degree turn from final approach course) area starts at the MAP and extends to 7.5 miles.

a. Primary Area. This area is divided into three sections.

(1) **Section 1A** is a continuation of the final approach area. It starts at the MAP and ends at the GPI. It has the same width as the final approach area at the MAP.

(2) **Section 1B** is centered on the missed approach course. It begins at the GPI and extends to a point 1 mile from the MAP outward along the missed

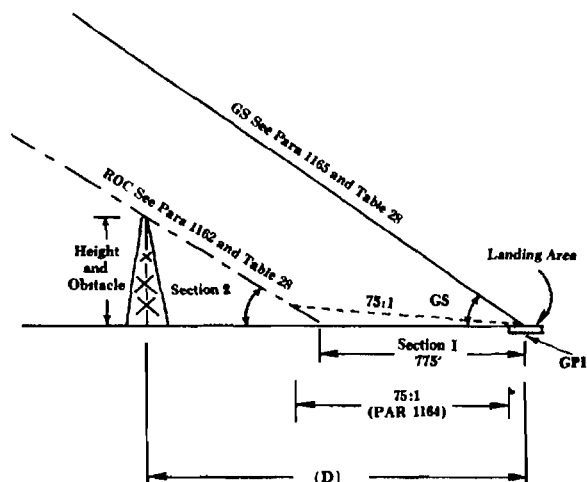

Figure 111. FINAL APPROACH AREA SURFACE AND OBSTACLE CLEARANCE. Paragraphs 1162 and 1164.

Table 30. BEGINNING POINT OF MISSED APPROACH SURFACE. Par. 1168.

GS Angle (Degrees)	3	6	9
Dist. below DH point (feet)	100	150	200

NOTE: This table may be interpolated.

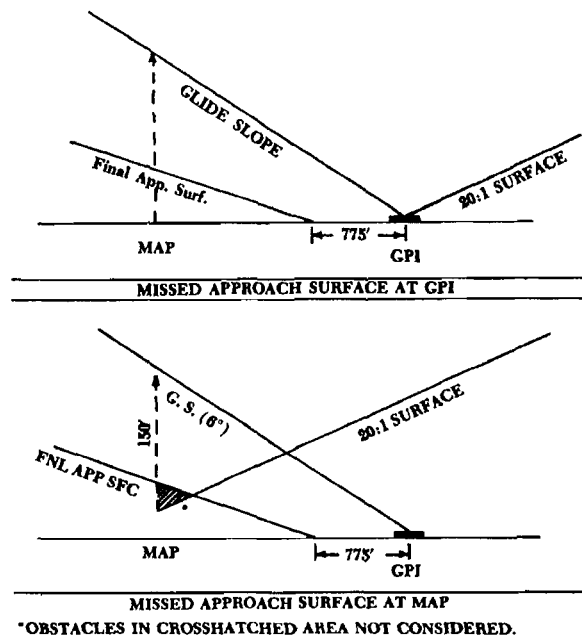

Figure 112. MISSED APPROACH SURFACE OPTIONS (Par 1168)

approach course. It has a beginning width the same as the final approach area at the MAP and expands uniformly to 4000 feet at 1 mile from the MAP.

(3) **Section 2** is centered on the continuation of the Section 1B course. It begins 1 mile from the MAP and ends 7.5 miles from the MAP. It has a beginning width of 4000 feet, expanding uniformly to a width equal to that of an initial approach area at 7.5 miles from the MAP.

b. Secondary Area. The secondary area begins at the MAP, where it has the same width as the final approach secondary area. In Section 1A the width remains constant from the MAP to the GPI, after which it increases uniformly to the appropriate airway width at 7.5 miles from the MAP. See Figure 113.

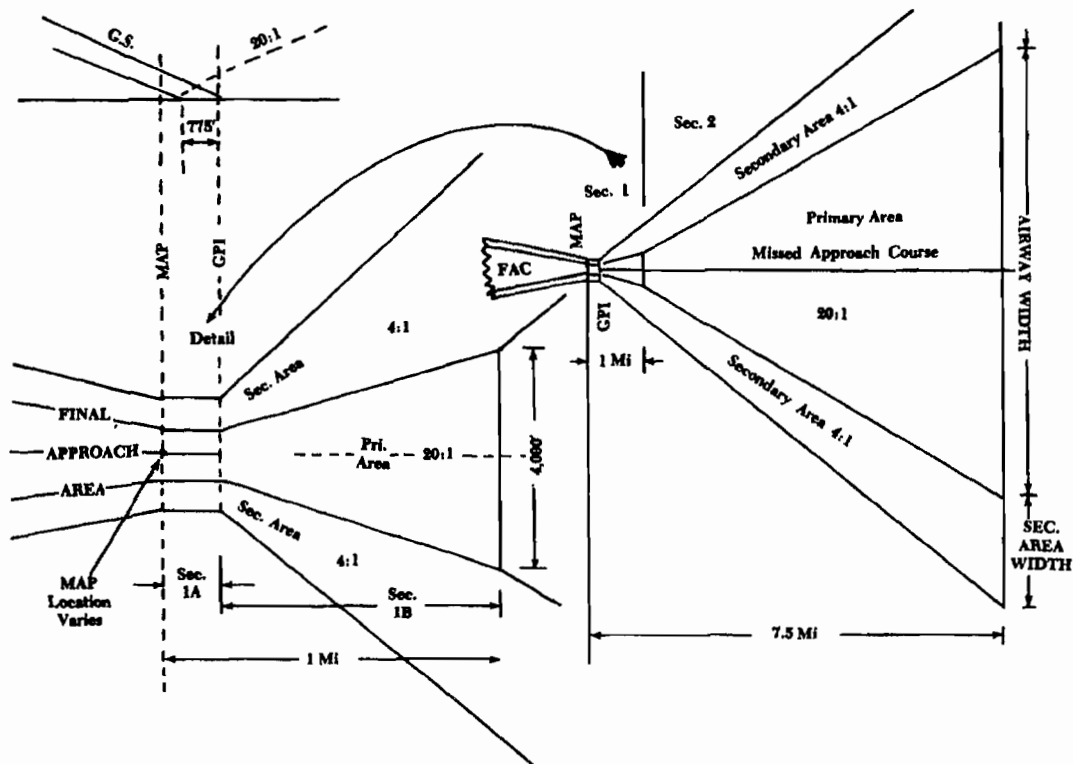

Figure 113. STRAIGHT MISSED APPROACH.

1170. TURNING MISSED APPROACH AREA. Where turns of more than 15 degrees are required in a missed approach procedure, they shall commence at an altitude which is at least 400 feet above the elevation of the landing area. Such turns are assumed to commence at the point where Section 2 begins. The turning flight track radius shall be 4000 feet (.66 miles).

a. Primary Area. The outer boundary of the Section 2 primary area shall be drawn with a 1.3 mile radius. The inner boundary shall commence at the beginning of Section 1B. The outer and inner boundary shall flare to the width of an initial approach area 7.5 miles from the MAP.

b. Secondary Area. Secondary areas for reduction of obstacle clearance are identified with Section 2. The secondary areas begin after comple-

tion of the turn. They are zero miles wide at the point of beginning and increase uniformly to the appropriate airway width at the end of Section 2. Positive course guidance is required to reduce obstacle clearance in the secondary area. See Figure 114.

1171. COMBINATION STRAIGHT AND TURNING MISSED APPROACH AREA. If a straight climb to an altitude greater than 400 feet is necessary prior to commencing a missed approach turn, a combination straight and turning missed approach area must be constructed. The straight portion of this missed approach area is divided into Sections 1 and 2A. The portion in which the turn is made is Section 2B.

a. Straight Portion. Sections 1 and 2A correspond respectively to Sections 1 and 2 of the normal straight missed approach area and are constructed

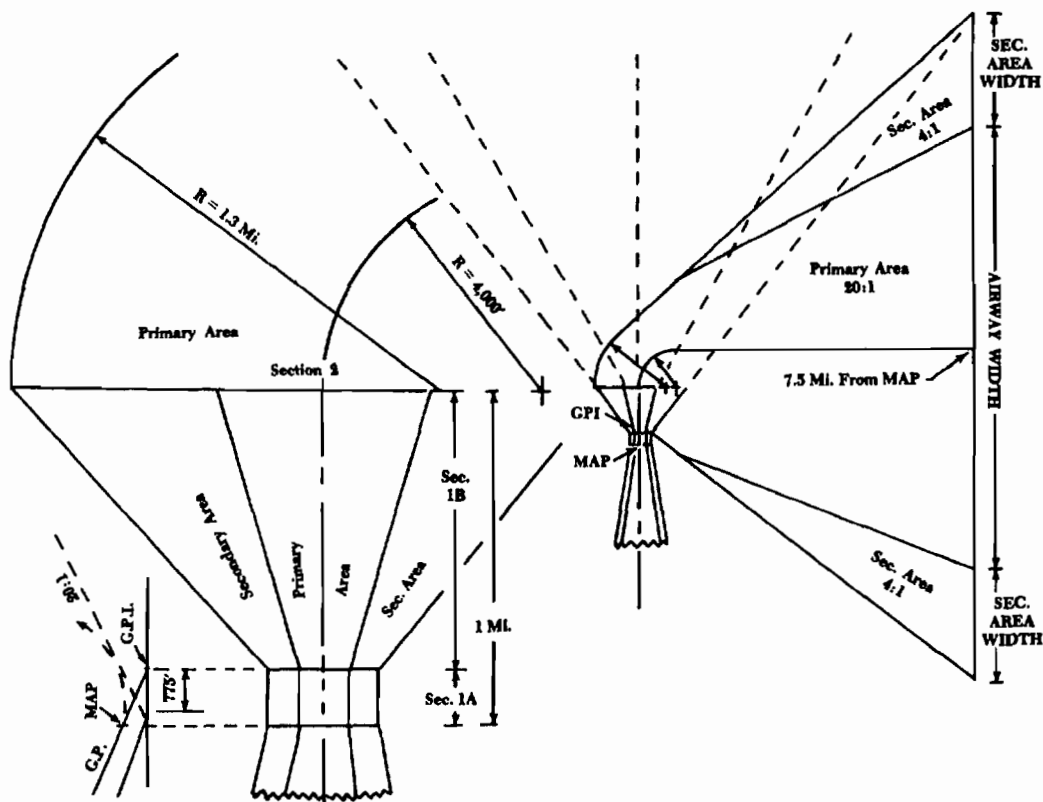

Figure 114. TURNING MISSED APPROACH AREA.
Par 1170.

as specified in Paragraph 1169 except that Section 2A has no secondary areas. Obstacle clearance is provided as specified in Paragraph 1119. The length of Section 2A is determined as shown in Figure 115, and relates to the need to climb to a specified altitude prior to commencing the turn. The line A'-B' marks the end of Section 2A. Point C' is 5300 feet from the end of Section 2A.

b. Turning Portion. Section 2B is constructed as specified in Paragraph 1169 except that it begins at the end of Section 2A instead of the end of Section 1. To determine the height which must be attained before commencing the missed approach turn, first identify the controlling obstacle on the side of Section 2A to which the turn is to be made. Then measure the distance from this obstacle to the nearest edge of the Section 2A area. Using this distance as illustrated in Figure 115, determine the height of

the 20:1 slope at the edge of Section 2A. This height plus 250 feet (rounded off to the next higher 20 foot increment) is the height at which the turn should be started. Obstacle clearance requirements in Section 2B are the same as those specified in Paragraph 1121 except that Section 2B is expanded to start at Point C if no fix exists at the end of Section 2A or if no course guidance is provided in Section 2 (see Figure 115).

NOTE: The missed approach areas expand uniformly to the appropriate airway width.

Section 11. Airport Surveillance Radar (ASR)

1172. INITIAL APPROACH SEGMENT. Paragraph 1041.a.(1) applies except that 90 degrees is changed to 120 degrees.

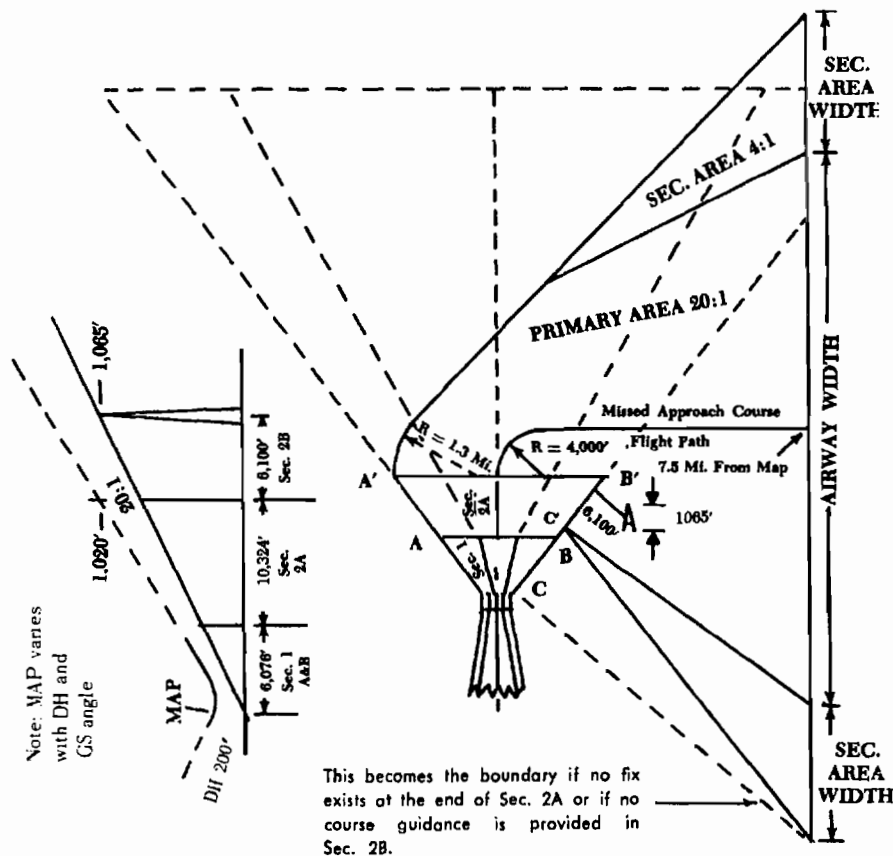

EXAMPLE:
DH is 200' MSL.
A 1065' controlling obstacle is 6100' from the near edge of Sec. 2A.
A 20:1 surface which clears the obstacle has a height of 760' MSL at the near edge of Section 2A.
 $6100' \div 20' = 305'$
 $1065 - 305 = 760'$
To determine minimum altitude at which the missed approach aircraft may start the turn add 250' obstacle clearance and round up the sum to the next higher 20' increment.
 $760' + 250' = 1010'$
Rounded up = 1020'
To climb 820' from DH 200' to the turning altitude (1020' MSL) at the 20:1 climb gradient requires 16,400'. Sec. 1 is 6076' long; therefore Section 2A is required to be 10,324' long.

Figure 115. COMBINATION STRAIGHT AND TURNING MISSED APPROACH. Paragraph 1171.

1173. INTERMEDIATE APPROACH SEGMENT. Paragraph 1042.b. applies with the exception that the maximum angle of intercept is changed to 120 degrees and Table 24 is used to determine the required minimum length of the intermediate segment.

1174. FINAL APPROACH SEGMENT. Paragraph 1044 applies except for subparagraphs a., c.(2) and d.

a. Alignment. Paragraphs 1116.a. and b. apply.

1175. MISSED APPROACH POINT. The identification of the MAP in Paragraph 1048 is changed as follows. The missed approach point is a point on the final approach course which is not farther than 2600 feet from the center of the landing area. See Figure 108. For point in space approaches the MAP is on the final approach course at the end of the final approach area.

1176.-1199. RESERVED.

CHAPTER 14. SIMPLIFIED DIRECTIONAL FACILITIES (SDF) PROCEDURES

1400. GENERAL. This chapter applies to approach procedures based on Simplified Directional Facilities (SDF). "SDF" is a directional aid facility providing only lateral guidance (front or back course) for approach from a final approach fix.

1401.-1409. RESERVED.

1410. FEEDER ROUTES. Criteria for feeder routes are contained in paragraph 220.

1411. INITIAL APPROACH SEGMENT. Criteria for the initial approach segment are contained in chapter 2, section 3

1412. INTERMEDIATE APPROACH SEGMENT. Criteria for the intermediate approach segment are contained in chapter 2, section 4.

1413. FINAL APPROACH SEGMENT. The final approach shall be made only "TOWARD" the facility because of system characteristics. The final approach segment begins at the final approach fix and ends at the missed approach point.

a. Alignment. The alignment of the final approach course with the runway centerline determines whether a straight-in or circling-only approach may be established.

(1) Straight-in. The angle of convergence of the final approach course and the extended runway centerline shall not exceed 30°. The final approach course should be aligned to intersect the extended runway centerline 3,000 feet outward from the runway threshold. When an operational advantage can be achieved, this point of intersection may be established at any point between the threshold and a point 5,200 feet outward from the threshold. Also, where an operational advantage can be achieved, a final approach course which does not intersect the runway center, or which intersects it at a distance

greater than 5,200 feet from the threshold may be established, provided that such a course lies within 500 feet laterally of the extended runway centerline at a point 3,000 feet outward from the runway threshold (see figure 48).

(2) Circling Approach. When the final approach course alignment does not meet the criteria for a straight-in landing, only a circling approach shall be authorized, and the course alignment should be made to the center of the landing area. When an operational advantage can be achieved, the final approach course may be aligned to any portion of the usable landing surface (see figure 49).

b. Area. The area considered for obstacle clearance in the final approach segment starts at the final approach fix (FAF) and ends at, or abeam, the runway threshold. It is a portion of a 10-mile long trapezoid that is centered longitudinally on the final approach course (see figure 14-1). For 6° course width facilities, it is 1,000 feet wide at, or abeam, the runway threshold and expands uniformly to 19,228 feet at 10 miles from the threshold. For 12° course width facilities, it is 2,800 feet wide at, or abeam, the runway threshold and expands uniformly to a width of 21,028 feet at 10 miles from the threshold. For course widths between 6° and 12°, the area considered for obstacle clearance may be extrapolated from the 6° and 12° figures to the next intermediate whole degree. For example, the width of the obstacle clearance area for a 9° course width would start at 1,900 feet and expand to 20,148 feet. The OPTIMUM length of the final approach segment is 5 miles. The MAXIMUM length is 10 miles. The MINIMUM length of the final approach segment shall provide adequate distance for an aircraft to make the required descent, and to regain course alignment when a turn is required over the facility. Table 14 shall be used to determine the minimum length needed to regain the course.

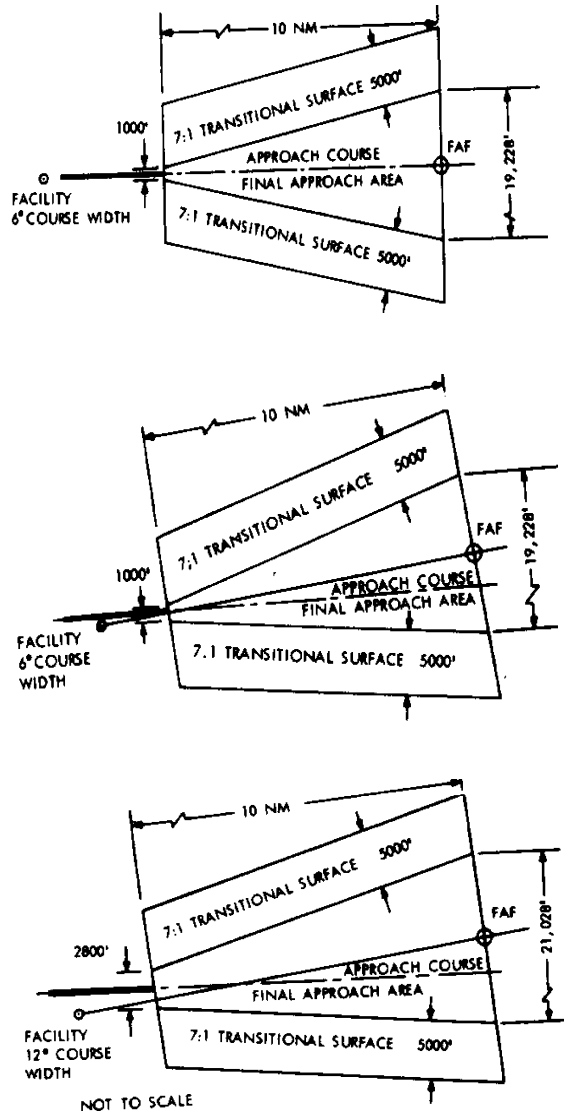

Figure 14-1. FINAL APPROACH AREAS WITH FAF.

c. Transitional Surfaces. Transitional surfaces are inclined planes with a slope of 7:1 that extend upward and outward 5,000 feet from the edge of the

final approach area. The transitional surfaces begin at a height no less than 250 feet below the MDA.

d. Obstacle Clearance.

(1) Straight-in Landing. The minimum obstacle clearance in the final approach area shall be 250 feet. In addition, the MDA established for the final approach area shall assure that no obstacles penetrate the transitional surfaces.

(2) Circling Approach. In addition to the minimum requirements specified in paragraph 1413d(1), obstacle clearance in the circling area shall be as prescribed in chapter 2, section 6.

e. Descent Gradient. Criteria for descent gradient are specified in paragraph 252.

f. Use of Fixes. Criteria for the use of radio fixes are contained in chapter 2, section 8.

g. Minimum Descent Altitudes. Criteria for determining the MDA are contained in chapter 3, section 2.

1414. MISSED APPROACH SEGMENT. Criteria for the missed approach segment are contained in chapter 2, section 7. For SDF procedures the missed approach point is a point on the final approach course that is NOT farther from the final approach fix than the runway threshold (first usable portion of the landing area for circling). The missed approach surfaces shall commence over the missed approach point at the required height. See paragraph 274, missed approach obstacle clearance.

1415. BACK COURSE PROCEDURES. Back course SDF procedures may be developed using these criteria except that the beginning point of the final approach obstacle clearance trapezoid is at the facility.

1416.-1499. RESERVED.

CHAPTER 15. AREA NAVIGATION (RNAV)

1500. GENERAL. This chapter applies to instrument procedures based on area navigation systems. Separate criteria are presented for VOR/DME and non-VOR/DME RNAV systems.

a. VOR/DME Systems. This includes systems using signals based solely upon VOR/DME, VORTAC, and TACAN facilities. VOR/DME is synonymous with the terms VORTAC or TACAN.

b. Non-VOR/DME Systems.

(1) Self-contained systems, including inertial navigation system (INS) and Doppler.

(2) Loran-C, Omega and Rho-Rho ground-based systems.

(3) Multi-sensor systems. Those which use a combination of input information.

1501. TERMINOLOGY. The following terms, peculiar to RNAV procedures, are defined as follows:

a. APT WP. A WP located on the FAC at or abeam the first usable landing surface, which is used for construction of the final approach area for a circling-only approach. (LORAN circling approaches only).

b. Alongtrack Distance (ATD). The ATD fix is an alongtrack (ATRK) position defined as a distance in NM, with reference to the next WP.

c. ATRK Fix Displacement Tolerance. Fix displacement tolerance along the flight track.

d. Crosstrack (XTRK) Fix Displacement Tolerance. Fix displacement tolerance to the left or right of the flight track.

e. Instrument Approach Waypoint. Fixes used in defining RNAV IAP's, including the feeder waypoint (FWP), the initial approach waypoint (IAWP), the intermediate waypoint (IWP), the final approach waypoint (FAWP), the RWY WP, and the APT WP, when required.

f. Non-VOR/DME RNAV is not dependent upon a reference facility and will hereinafter be referred to as non-VOR/DME, which includes the following:

(1) Long-Range Navigation (Loran-C). Loran-C is a long-range radio navigation system. A Loran-C

"chain" consists of four transmitting facilities, a master and three secondaries, each transmitting in the same group repetition interval (GRI).

(2) Omega. A low frequency navigation system using precise timed pulsed signals from eight ground transmitting stations spaced long distances apart. Limited to en route only.

(3) Inertial Navigation System (INS). A self-contained system which utilizes gyros to determine angular motion and accelerometers to determine linear motion. They are integrated with computers to provide several conditions which include true heading, true air speed, wind, a glidepath, velocity, and position.

(4) Doppler. A self-contained system which determines velocity and position by the frequency shift of a signal transmitted from the aircraft and reflected from the surface back to the aircraft.

(5) Global Positioning System (GPS). A system of satellites providing three-dimensional position and velocity information. Position and velocity information is based on the measurement of the transit time of radio frequency (RF) signals from satellites.

(6) Rho-Rho. A system based on two or more DME ground facilities.

(7) Multi-Sensor System. Based on any VOR/DME or non-VOR/DME certified approved system or a combination of certified approved systems. The non-VOR/DME criteria apply.

g. Reference Facility. A VOR/DME, VORTAC or TACAN facility used for the identification and establishment of an RNAV route, WP, or SIAP.

h. RNAV Descent Angle. A vertical angle defining a descending flightpath from the FAF to the RWY WP.

l. Routes. Two subsequently related WP's or ATD fixes define a route segment.

(1) Jet/Victor Routes.

(2) Random Routes. Any airway not established under the jet/victor designation. This is normally used to refer to a route that is not based on VOR radials and requires an RNAV system.

j. RWY WP. A WP located at the runway threshold and used for construction of the final approach area when the FAC meets straight-in alignment criteria.

k. Tangent Point (TP). The point on the VOR/DME RNAV route centerline from which a line perpendicular to the route centerline would pass through the reference facility.

l. Tangent Point Distance (TPD). Distance from the reference facility to the TP.

m. Time Difference (TD) Corrections. Loran-C systems use the time of signal travel from ground facilities to the aircraft to compute distance and position. The time of signal travel varies seasonally within certain geographical areas. The TD correction factor is used to correct these seasonal variations for each geographical area. RNAV criteria assume local TD corrections will be applied.

n. Turn Anticipation. The capability of RNAV systems to determine the point along a course, prior to a turn WP, where a turn should be initiated to provide a smooth path to intercept the succeeding course, and to enunciate the information to the pilot.

o. Turn WP. A WP which identifies a change from one course to another.

p. VOR/DME RNAV is dependent on VOR/DME, VORTAC, or TACAN. It is a system using radials and distances to compute position and flight track and will hereinafter be referred to as VOR/DME.

q. WP. A predetermined geographical position used for route definition and progress reporting purposes that is defined by latitude/longitude. For VOR/DME systems, it is defined by the radial/distance of the position from the reference facility.

r. WP Displacement Area. The rectangular area formed around and centered on the plotted position of a WP. Its dimensions are plus-and-minus the appropriate ATRK and XTRK fix displacement tolerance values which are found in tables 15-1, 15-2, and 15-3.

1502. PROCEDURE CONSTRUCTION. RNAV procedural construction requirements are as follows:

a. Reference Facility. An RNAV approach procedure shall be supported by a single reference facility.

b. WP. A WP shall be used to identify the point at which RNAV begins and the point at which RNAV

ends, except when the RNAV portion of the procedure terminates at the MAP, and the MAP is an ATD fix.

c. Segment. Approach segments begin and end at the WP or ATD fix.

(1) The segment area considered for obstacle clearance begins at the earliest point the WP or ATD fix can be received and, except for the final approach segment, ends at the plotted position of the fix.

(2) Segment length is based on the distance between the plotted positions of the WP or ATD fix defining the segment ends.

(3) Segment widths are specified in appropriate paragraphs of this chapter, but in no case will they be narrower than XTRK fix displacement tolerances for that segment.

(4) Minimum segment widths are also determined/limited in part according to WP location relative to the reference facility. This limiting relationship is depicted in figure 15-2 and explained in the note following figure 15-2.

d. Fix Displacement. Except in the case of the MAP overlapping the RWY WP or APT WP (see paragraph 1532), the ATRK fix displacement tolerance shall not overlap the plotted position of the adjacent fix. Additionally, except for a turn at a MAP designated by a WP, WP displacement tolerances shall be oriented along the courses leading to and from the respective WP (see figure 15-17).

e. Turning Areas. Turning area expansion criteria shall be applied to all turns, en route and terminal, where a change of direction of more than 15° is involved. See paragraphs 1510c and 1520.

f. Cone of Ambiguity. The primary obstacle clearance area at the minimum segment altitude shall not be within the cone of ambiguity of the reference facility. If the primary area for the desired course lies within the cone of ambiguity, the course should be relocated or the facility flight inspected to verify that the signal is adequate within the area. FAA Order 9840.1, U.S. National Aviation Handbook for the VOR/DME/TACAN Systems, defines the vertical angle coverage. Azimuth signal information permitting satisfactory performance of airborne components is not provided beyond the following ranges:

(1) VOR - beyond 60° above the radio horizon.

(2) TACAN - beyond 40° above the radio horizon (see figure 15-1).

g. Use of ATD Fixes. ATD fixes are normally used in lieu of approach WP's when no course change is required at that point. An ATD fix shall not be used in lieu of a RWY WP. The FAF, MAP, and any stepdown fixes may be defined by ATD fixes.

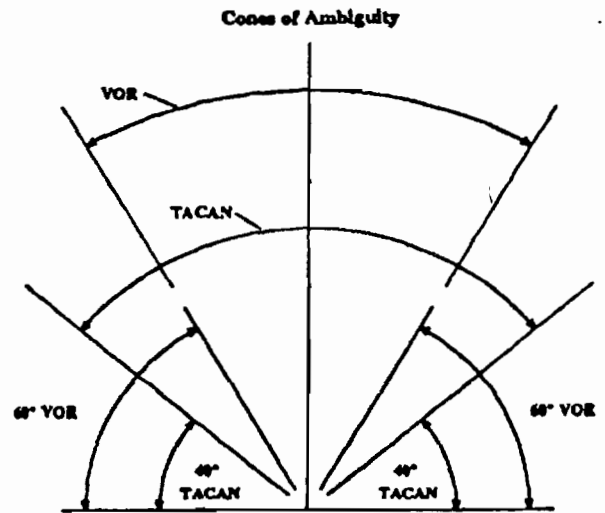

Figure 15-1. CONES OF AMBIGUITY.
Par 1502.

AREA NAVIGATION ROUTE WIDTH SUMMARY

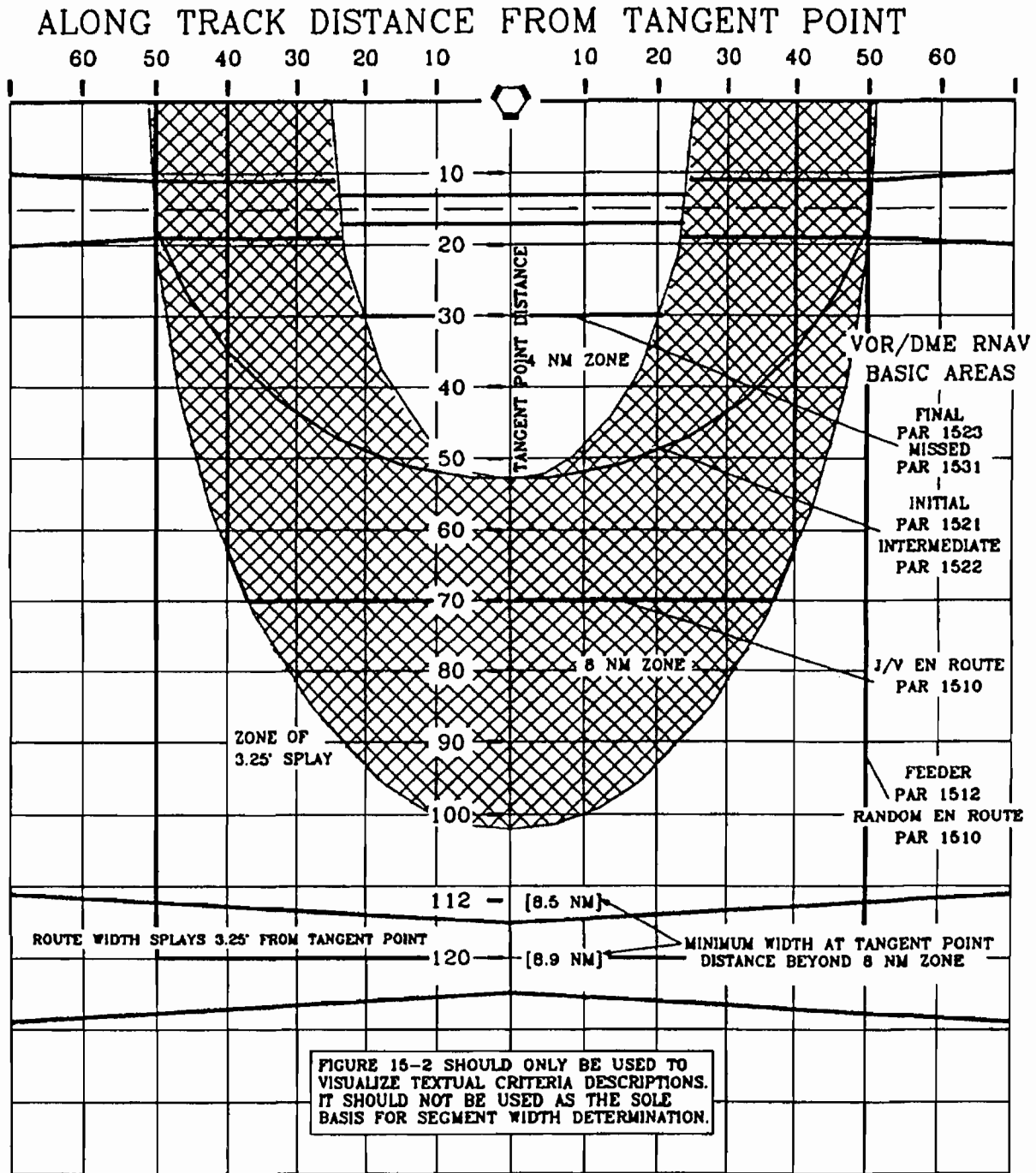

Figure 15-2. Par 1502.

NOTE: Segment width (for instance at a specific WP) is based upon a mathematical relationship between TPD, and the ATD from the TP, at that point. This relationship is represented by the two elliptical curves shown on figure 15-2. One curve encloses the "4 NM ZONE" wherein the segment primary area width is ± 2 miles from route centerline. The other curve encloses the "8 NM ZONE" wherein the segment primary area width is ± 4 miles from route centerline.

The formula for the 4 NM ZONE curve is:
$$\frac{x^2}{(25.5)^2} + \frac{y^2}{(53)^2} = 1$$

The formula for the 8 NM ZONE curve is:
$$\frac{x^2}{(51)^2} + \frac{y^2}{(102)^2} = 1$$

where X = ATD from the TP
and, Y = TPD

APPLICATION:

4 NM ZONE: To determine the maximum acceptable ATD value associated with a given TPD value and still allow segment primary width at ± 2 miles.

Given: TPD = 40 miles (this is the Y-term)

Find: ATD value (this is the X-term)

$$x = 25.5 \sqrt{1 - \frac{y^2}{(53)^2}}$$

$$x = 25.5 \sqrt{1 - \frac{(40)^2}{(53)^2}} = 16.73 \text{ miles}$$

i.e., for TPD at 40 miles, if the ATD exceeds 16.73 miles, the primary area width must be expanded to ± 4 miles.

8 NM ZONE: Given: ATD = 30 miles

Find: TPD Maximum for ± 4 miles width

$$y = 102 \sqrt{1 - \frac{x^2}{(51)^2}}$$

$$y = 102 \sqrt{1 - \frac{(30)^2}{(51)^2}} = 82.49 \text{ miles}$$

i.e., for ATD at 30 miles, the TPD must not exceed 82.49 miles and still allow ± 4 miles width.

APPLICATION: The formulas can tell you whether the specific point is inside or outside either zone area. For instance:

Given: ATD = 40 miles, and TPD = 65 miles. Determine if the location is within the 8 NM ZONE.

The basic formula for the 8 NM ZONE is an equation made equal to 1. By substituting the specific values (ATD = 40, and TPD = 65), the point will be determined to be OUTSIDE the zone if the resultant is > 1 , and INSIDE the zone if the resultant is $<$ or $= 1$.

$$\frac{x^2}{(51)^2} + \frac{y^2}{(102)^2} = 1$$

by substitution:

$$\frac{(40)^2}{(51)^2} + \frac{(65)^2}{(102)^2} = 0.615 + 0.406 = 1.021$$

Since this is >1, the point lies OUTSIDE the 8 NM ZONE.

For distances beyond 102 miles of the TPD, the route width expands an additional 0.25 miles each side of the route centerline for each 10 miles the TPD is beyond 102 miles.

Example: 112 NM-102 NM = 10 NM beyond 102 TPD.

- a. (10 NM/10 NM) X .25 NM (rate per 10 NM) = 0.25 increase.
- b. 0.25 NM + 4 NM = 4.25 NM each side centerline.
- c. 4.25 X 2 = 8.5 NM (total width) at the 112 TPD.

h. PCG. All RNAV segments shall be based on PCG, except that a missed approach segment without PCG may be developed when considered to provide operational advantages and can be allowed within the obstacle environment.

1503. RESERVED.

1504. REFERENCE FACILITIES. Reference facilities shall have collocated VOR and DME components. For terminal procedures, components within 100 feet of each other are defined as collocated. For en route procedures, components within 2,000 feet of each other are defined as collocated.

1505. WP's. RNAV WP's are used for navigation reference and for ATC operational fixes, similar to VOR/DME ground stations, and intersections used in the conventional VOR structures.

a. Establishment. WP's shall be established along RNAV routes at the following points:

- (1) At end points.
- (2) At points where the route changes course.
- (3) At holding fixes.
- (4) At other points of operational benefit, such as route junction points which require clarity.

(5) For VOR/DME WP's, one WP must be associated with each reference facility used for en route navigation requirements. If a segment length exceeds 80 miles and no turning requirement exists along the route, establish a WP at the TP.

b. WP. WP placement is limited by the type of RNAV system as follows:

(1) VOR/DME WP's or route segments shall not be established outside of the service volume of the reference facility and shall be limited to the values contained in tables 15-1 and 15-2.

(2) Non-VOR/DME WP's or route segments shall not be established outside of the area in which the particular system signal has been approved for IFR operation.

(3) Self-contained systems such as INS and Doppler do not have limitations on WP placement.

(4) **Fix Displacement Tolerances.** Tables 15-1 and 15-2 show fix displacement tolerances for VOR/DME systems. Table 15-3 shows fix displacement tolerances for non-VOR/DME systems. When the fix is an ATD fix, the ATRK fix and XTRK displacement tolerances are considered to be the same as a WP located at that fix.

c. Defined WP Requirements.

(1) **VOR/DME WP's.** Each WP shall be defined by:

(a) **A VOR radial** - developed to the nearest hundredth of a degree.

(b) **DME distance** - developed to the nearest hundredth of a mile; and

(c) **Latitude/longitude** - in degrees, minutes, and seconds to the nearest hundredth.

(2) **Non-VOR/DME WP's.** Each WP shall be defined by latitude and longitude in degrees, minutes, and seconds developed to the nearest hundredth. Rho-Rho WP's shall also be developed to the nearest hundredth of a mile.

(3) **Station elevation of the reference facility** shall be defined and rounded to the nearest 20-foot increment.

1506. RWY WP AND APT WP. Straight-in procedures shall incorporate a WP at the runway threshold. Circling procedures shall incorporate an APT WP at or abeam the first usable landing surface. See figure 15-3. These WP's are used to establish the length and width of the final approach area.

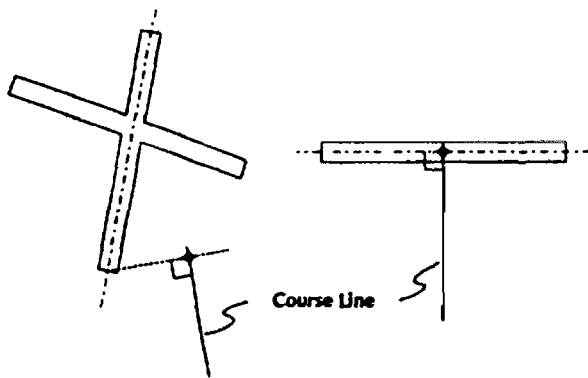

Figure 15-3. LOCATION OF APT WP.
Par 1506.

1507. HOLDING. Chapter 2, section 9, applies, except for paragraph 292d. When holding is at an RNAV fix, the selected pattern shall be large enough to contain the entire area of the fix displacement tolerance within the primary area of the holding pattern.

a. VOR/DME Pattern Size Selection. For VOR/DME, the distance from the WP to the reference facility shall be applied as the "fix-to-NAVAID distance" in FAA Order 7130.3, Holding Pattern Criteria, figure 3, pattern-template selection.

b. Non-VOR/DME Pattern Size Selection. For non-VOR/DME, use the 15-29.9 NM distance column for terminal holding procedure, and 30 NM or over column for en route holding, FAA Order 7130.3.

1508.-1509. RESERVED.

SECTION 1. EN ROUTE CRITERIA.

1510. EN ROUTE OBSTACLE CLEARANCE AREAS. En route obstacle clearance areas are identified as primary and secondary. These designations apply to straight and turning segment obstacle clearance areas. The required angle of turn connecting en route segments to other en route, feeder, or initial approach segments shall not exceed 120°. Where the turn exceeds 15°, expanded turning area construction methods in paragraph 1510c apply.

a. Primary Area. The primary obstacle clearance area is described as follows:

(1) **VOR/DME Basic Area.** The area is 4 miles each side of the route centerline, when the TPD is 102 miles or less and the TPD/ATD values do not exceed the limits of the 8 NM zone. The width increases at an angle of 3.25° as the ATD increases for that portion of the area where the route centerline lies outside the 8 NM zone. See figure 15-4. When the TPD exceeds the 102-mile limit, the minimum width at the TPD expands greater than ± 4 miles at a rate of 0.25 miles on each side of the route for each 10 miles the TPD is beyond 102 miles. See figures 15-2, 15-5, and table 15-1. When the widths of adjoining route segments are unequal for reasons other than transition of zone boundaries, the following apply:

(a) If the TP of the narrower segment is on the route centerline, the width of the narrower segment includes that additional airspace within the lateral extremity of the wider segment, where the route segments join, thence toward the TP of the narrower route segment until intersecting the boundary of the narrower segment (see figure 15-6).

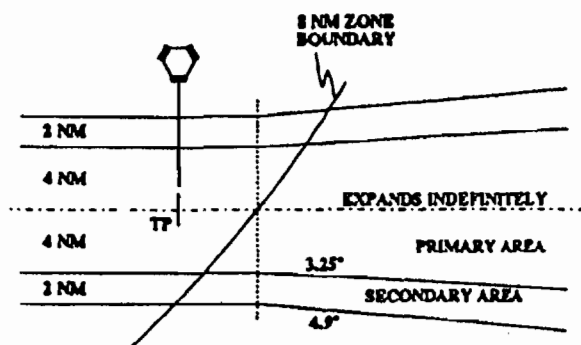

Figure 15-4. VOR/DME BASIC AREA.
Par 1510a(1)

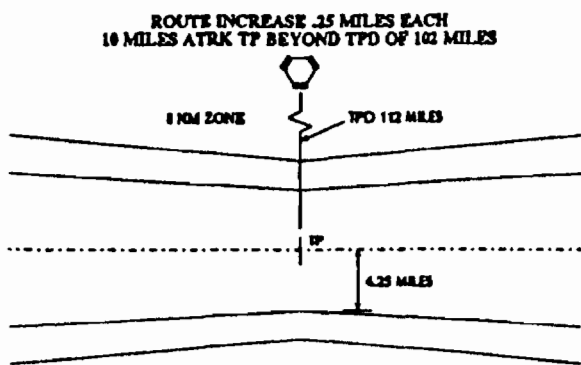

Figure 15-5. VOR/DME BASIC AREA.
Par 1510a(1) and b(1).

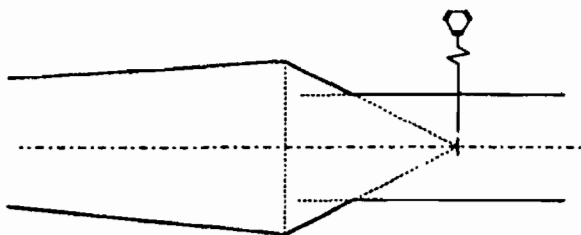

Figure 15-6. UNEQUAL JOINING ROUTE
SEGMENTS. Par 1510a(1)(a).

(b) If the TP of the narrower segment is on the route centerline extended, the width of the narrower segment includes that additional airspace within lines from the lateral extremity of the wider segment where the route segments join, thence toward the TP until reaching the point where the narrower segment terminates, changes direction, or until intersecting the boundary of the narrower segment (see figure 15-7).

(2) Non-VOR/DME Basic Area. The area is 4 miles each side of the route centerline at all points. Non-VOR/DME primary boundary lines do not splay.

(3) Termination Point. An RNAV route termination point shall be at a WP. The primary area extends beyond the route termination point. The boundary of the area is defined by an arc which connects the two primary boundary lines. The center of the arc is located at the most distant point on the edge of the WP displacement area on the route centerline (see figure 15-8).

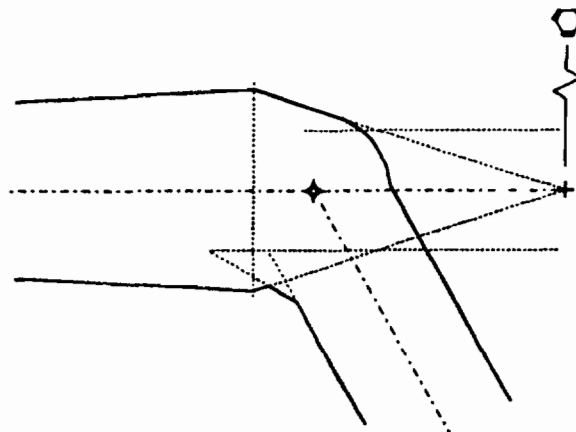

Figure 15-7. UNEQUAL JOINING ROUTE
SEGMENTS WITH A TURN.
Par 1510a(1)(b).

b. Secondary Areas.

(1) VOR/DME Basic Area. The VOR/DME secondary obstacle clearance area extends 2 miles on each side of the primary area and splays 4.9° where the primary splays at 3.25°. See figure 15-4. The secondary area beginning width does not increase beyond the 102-mile TPD.

(2) Non-VOR/DME Basic Area. The non-VOR/DME secondary obstacle clearance areas are a constant 2-mile lateral extension on each side of the primary area.

(3) Termination Point. The secondary obstacle clearance area extends beyond the arc which defines the termination point primary area by an amount equal to the width of the secondary area at the latest point the WP can be received (see figure 15-8).

c. Construction of Expanded Turning Areas. Obstacle clearance areas shall be expanded to accommodate turns of more than 15°. The primary and secondary obstacle clearance turning areas are expanded by outside and inside areas (see figure 15-9). The inside expansion area is constructed to accommodate

a turn anticipation area. Outside expansion area is provided to accommodate overshoot at high speeds and excessive wind conditions. No portion of the primary area at the minimum segment altitude may be in the cone of ambiguity for VOR/DME RNAV routes.

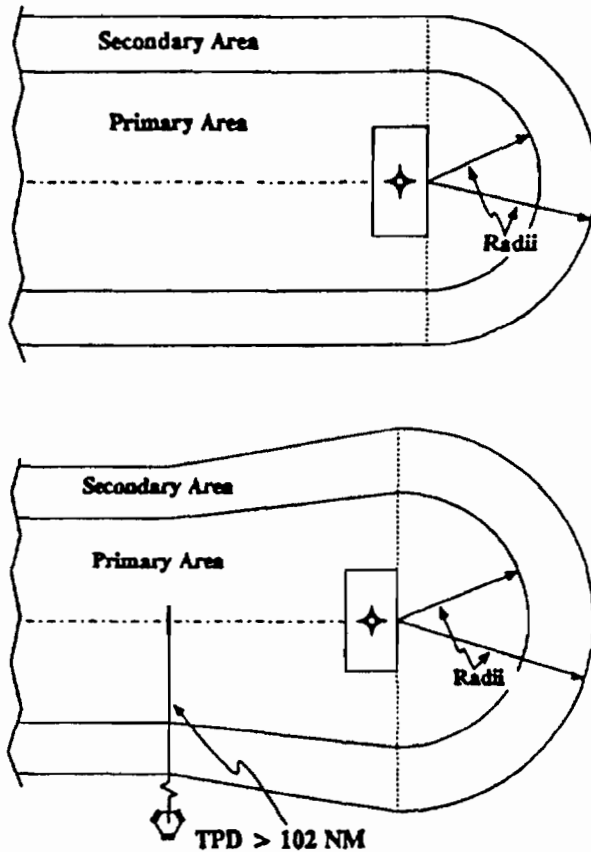

Figure 15-8. TERMINATION POINTS.
Par 1510a(3) and 1510b(3).

(1) **Outside Expansion Area.** Determine the expanded area at the outside of the turn as follows:

(a) Construct a line perpendicular to the route centerline 3 miles prior to the latest point the fix can be received or to a line perpendicular to the route centerline at the plotted position of the fix, whichever occurs last. For altitudes 10,000 feet or greater, construct a line perpendicular to the plotted position of the fix. This perpendicular line is a base line for constructing arc boundaries.

(b) From a point on the base line, strike an 8-mile arc from the outer line of the fix displacement area on the outside of the turn to a tangent line to a second 8-mile arc. The second arc is struck from a point on the

base line inside the inner line of the fix displacement area to a 30° tangent line to the primary boundary line. From a point where an extension of the base line intersects the primary area outer boundary line, connect the 8-mile arc with a line tangent to the arc.

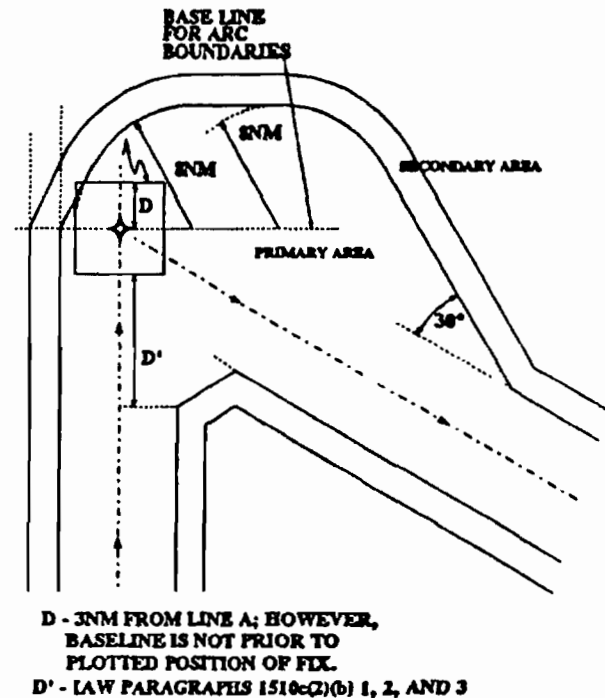

D - 3NM FROM LINE A; HOWEVER,
BASELINE IS NOT PRIOR TO
PLOTTED POSITION OF FIX.
D' - LAW PARAGRAPHS 1510c(2)(b) 1, 2, AND 3

Figure 15-9. EXPANDED TURNING AREAS.
Par 1510c.

(c) Strike arcs from the center points used for the primary area expansion and provide a parallel expansion of 2 miles of the secondary area at the turn.

(d) Connect the extremities with a straight-line tangent to the two associated arcs.

(e) Draw the remaining secondary area boundary 2 miles outside the boundary of the primary area.

(f) If the width of the primary area at the turn point is greater than 8 miles, the expanded area is constructed in the same manner, as outlined in paragraph 1510c(1), using the primary area width at the point where the route changes course as the radius of the arc in place of 8 NM and constructing the secondary area of constant width equal to the width of the secondary area at the turn point.

(2) **Inside Expansion Area.** Determine the expanded area at the inside of the turn as follows:

(a) Determine the fix area by application of the ATRK and XTRK fix displacement tolerances.

(b) Prior to the earliest point the WP (oriented along the course leading to the fix) can be received, locate a point on the primary area boundary at one of the following distances:

1 Three miles below 10,000 feet MSL; three and one-half miles when the turn exceeds 112°.

2 Seven miles for 10,000 feet MSL up to but not including FL 180.

3 Twelve miles for FL 180 and above.

(c) From this point, splay the primary area by an angle equal to one-half of the course change.

(d) Draw the secondary area boundary 2 miles outside the boundary of the primary area.

d. **TPD/WP Limitation.** WP's for the Jet/Victor Airway structure shall be limited to the 8 NM zone, a TPD of 70 miles or less, and an ATD fix from the TP of 40 miles or less. WP's for random airway structure shall be limited to a TPD of 120 miles or less and an ATD fix from the TP of 50 miles.

e. **Joining RNAV with non-RNAV Route Segments.**

(1) If the RNAV and non-RNAV segments have the same width at the point of transition, the segments are joined at that location and RNAV criteria are continued in the direction of the RNAV segment.

(2) If the RNAV segment is narrower at the location of the transition, the segments shall be joined according to paragraph 1512b(1)(b).

(3) If the RNAV segment is wider at the location of the transition, the boundaries shall taper from the transition location toward the non-RNAV segment at an angle of 30° until joining the boundaries at the RNAV segments. If the location of transition includes a turn, the width of the RNAV segment is maintained and the turn area constructed according to this chapter. After the completion of the turn area, the boundaries shall taper at an angle of 30° until passing the non-RNAV boundaries.

1511. **OBSTACLE CLEARANCE.** Paragraphs 1720 and 1721 apply, except that the width of the VOR/DME secondary area is 2 miles at the point of splay initiation and the value 236 feet for each additional mile in paragraph 1721 is changed to 176 feet/NM. Non-

VOR/DME systems do not splay. Obstacles in the secondary area are measured perpendicular to the course centerline, except for the expanded turn areas. Obstacles in these areas are measured perpendicular to the primary area boundary, or its tangent, to the obstacle.

1512. **FEEDER ROUTES.** When the IAWP is not part of the en route structure, it may be necessary to designate feeder routes from the en route structure to another FWP or the IAWP.

a. The required angle of turn for the feeder-to-feeder and feeder-to-initial segment connections shall not exceed 120°. Where the angle exceeds 15°, turning area criteria in section 2 apply. En route vertical and lateral airway obstacle clearance criteria shall apply to feeder routes. The minimum altitudes established for feeder routes shall not be less than the altitude established at the IAWP. WP's for feeder routes shall be limited to a TPD of 120 miles or less and an ATD fix from the TP of 50 miles or less.

b. **Obstacle Clearance Areas.** Obstacle clearance areas are identified as primary and secondary. These designations apply to straight segment and turning segment obstacle clearance areas.

(1) **Primary Area.** The primary obstacle clearance area is derived from figure 15-2 and the associated formulas. It is described as follows:

(a) **VOR/DME Basic Area.** The area is 4 miles each side of the route centerline when the TPD is 102 miles or less and the TPD/ATD values do not exceed the limits of the 8 NM zone. The route width increases at an angle of 3.25° as the ATD increases for that portion of the area where the route centerline lies outside the 8 NM zone (see figure 15-4). When the TPD exceeds the 102-mile limit, the minimum width at the TP increases at a rate of 0.25 miles on each side of the route centerline for each 10 miles the TPD is beyond 102 miles. Methodology for joining route segments of differing widths is contained in paragraph 1510a(1). See table 15-2.

(b) **Non-VOR/DME Basic Area.** The area is 4 miles each side of the course centerline at all points, except for the 20-mile portion of the course just prior to the IAWP where it tapers linearly from 4 miles to 2 miles each side of centerline. Where a WP or a fix is located less than 20 miles prior to the IAWP, the taper begins at that point (see figure 15-10).

(2) **Secondary Areas.**

(a) VOR/DME Basic Areas. Secondary obstacle clearance areas extend laterally 2 miles on each side of the primary area and splay 4.9° in the region where the primary area splays at 3.25° (see figure 15-11 and paragraph 1512b(1)(a)).

(b) Non-VOR/DME Basic Area. Non-VOR/DME secondary areas are a constant 2-mile lateral extension on each side of the primary area, except where the basic area tapers as specified in paragraph 1512b(1)(b). Over this area, the secondary area tapers linearly from 2 miles each side of the primary to 1 mile each side of the primary area.

(3) Obstacle Clearance. Paragraph 220 applies.

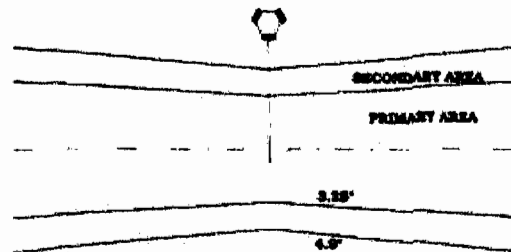

Figure 15-11. VOR/DME SECONDARY AREAS SPLAY 4.9°. Par 1512b(2)(a).

1513-1519. RESERVED.

SECTION 2. TERMINAL CRITERIA.

1520. TERMINAL TURNING AREA EXPANSION. Obstacle clearance areas shall be expanded to accommodate turn anticipation. Outside expansion is not required for terminal procedures. Inside expansion applies to all turns of more than 15° within SIAP's, except turns at the MAP. Paragraph 1534 satisfies early turn requirements for the MAP. Determine the expanded area at the inside of the turn as follows:

a. Determine the ATRK Fix Displacement Tolerance.

b. Locate a point on the edge of the primary area at a distance prior to the earliest point the WP can be received. The distance of turn anticipation (DTA) is measured parallel to the course leading to the fix and is determined by the turn anticipation formula:

$$DTA = 2 \times \tan (\text{turn angle} \div 2)$$

c. From this point, splay the primary area by an angle equal to one-half of the course change (see figure 15-12).

d. Secondary Area Boundary:

(1) When the obstacle clearance area boundaries of the preceding and following segments of the WP are parallel with the course centerline, construct the secondary area boundary, parallel with the expanded turn anticipation primary area boundary, using the width of the preceding segment secondary area.

(2) When the obstacle clearance area boundaries of the preceding and/or following segments

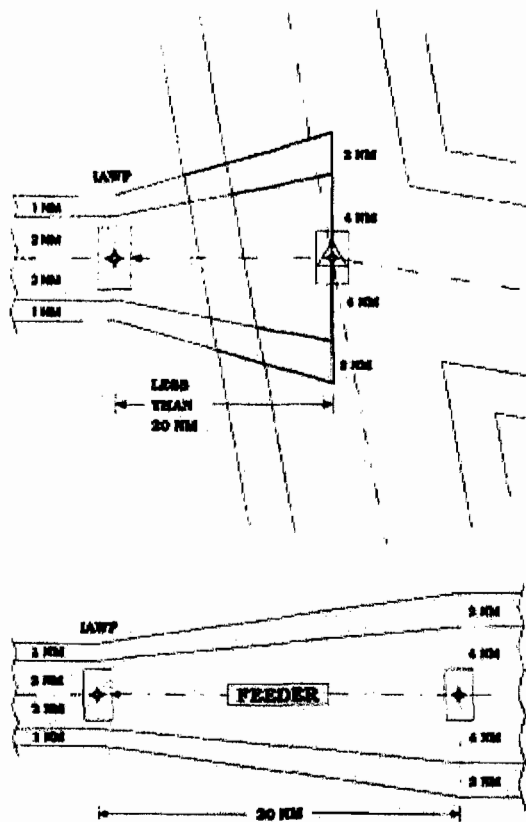

Figure 15-10. FEEDER ROUTES CONNECTING NON-VOR/DME BASIC AREAS. Par 1512b(1)(b).

taper, construct the secondary area boundary by connecting the secondary area at points abeam the primary expansion area where it connects to the preceding/following segments of the primary area boundaries.

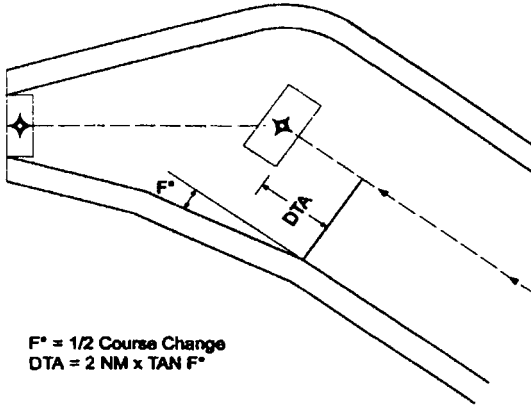

Figure 15-12. TURN ANTICIPATION SPLAY.
 Par 1520.

e. When the boundary of the expanding turn area will not connect with the boundary of the primary area of the following segment, join the expanded area at the boundary abeam the plotted position of the next WP or at the latest reception point of the RWY WP or APT WP, as appropriate (see figure 15-13).

f. **Obstacle Evaluation of the Expanded Area.** Evaluate the primary and secondary expansion areas using the ROC for the segment following the turn WP (see figures 15-13 and 15-14).

1521. INITIAL APPROACH SEGMENT. The initial approach segment begins at the IAWP and ends at the IWP. See figures 15-15, 15-16, and 15-17. For VOR/DME systems, the distance from the reference facility to the IAWP shall not exceed 53 miles, nor exceed the TPD or ATD values associated with the limits of the 8 NM zone (see figure 15-2).

a. **Alignment.** The angle of intercept between the initial and intermediate segment shall not exceed 120°.

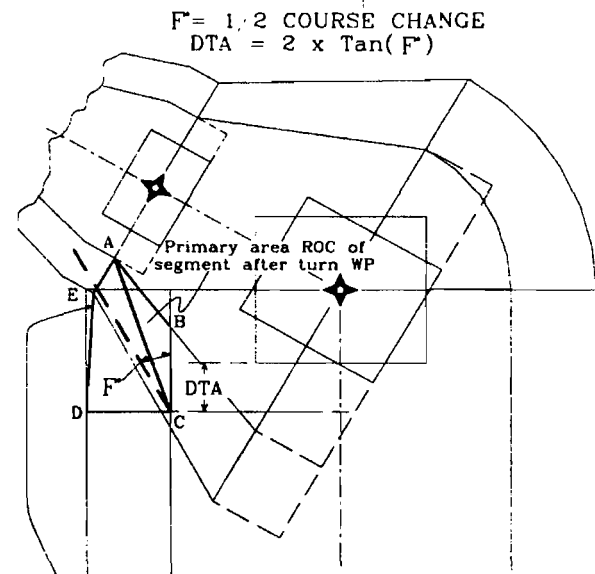
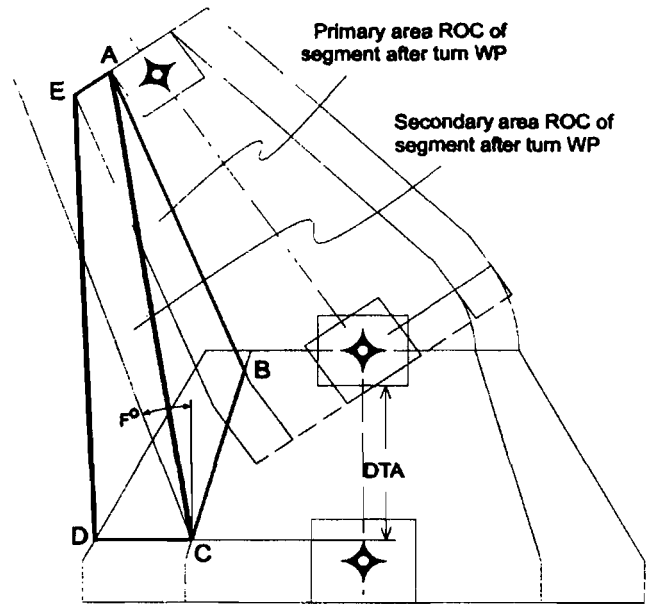

NOTE: Secondary area boundary line for expanded area. Enclosed areas A, B, C are primary areas using ROC of segment following turn WP. Enclosed areas A, C, D, E are secondary areas using ROC of segment following turn WP. Obstacle slope in these areas are perpendicular to lines AC

Figure 15-13. SHALLOW-ANGLED TURN ANTICIPATION ILLUSTRATIONS. TAPERING INTERMEDIATE AND CONSTANT WIDTH SEGMENT. ROC APPLICATIONS.
 Par 1520e and f.

b. **Course Reversal.** When the procedure requires a course reversal, a holding pattern shall be established in lieu of a PT. If holding is established over the FAF, paragraph 1507 applies. If holding is established over the FAF, the FAF shall be a WP, and paragraph 234e(1) applies. The course alignment shall be within 15° of the FAC. If holding is established over the IWP, paragraph 234e(2) applies. The course alignment shall be within 15° of the intermediate course. Where a feeder segment leads to the course reversal, the feeder segment shall terminate at the plotted position of the holding WP (see figure 15-15).

c. **Area.**

(1) **Length.** The initial approach segment has no standard length. It shall be sufficient to permit any altitude changes required by the procedure and shall not exceed 50 miles unless an operational requirement exists.

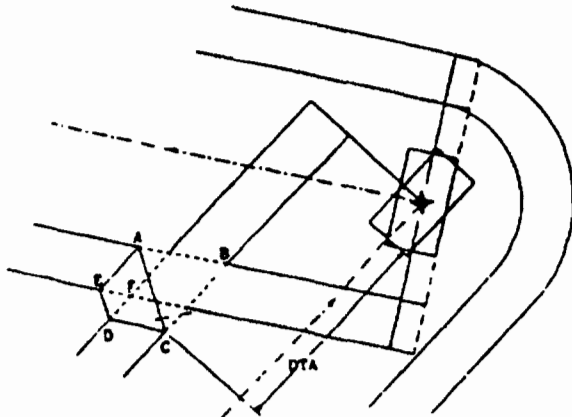

Enclosed area A, B, C is primary area ROC of segment following turn WP. Area A, C, D, E is secondary area ROC of segment following turn WP. Obstacle slope in this area is perpendicular to line A-C.

Figure 15-14. TURN ANTICIPATION AREAS.
Par 1520f.

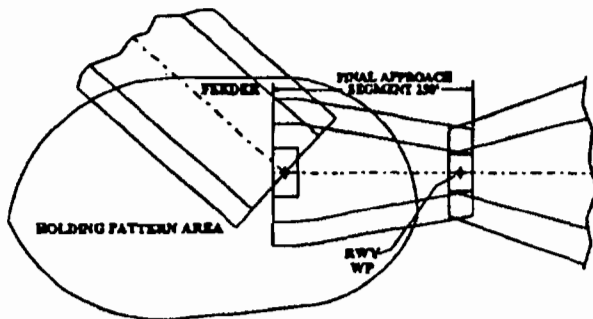

Figure 15-15. HOLDING PATTERN AND FINAL APPROACH, AND ASSOCIATED ROC.
Par 1521b.

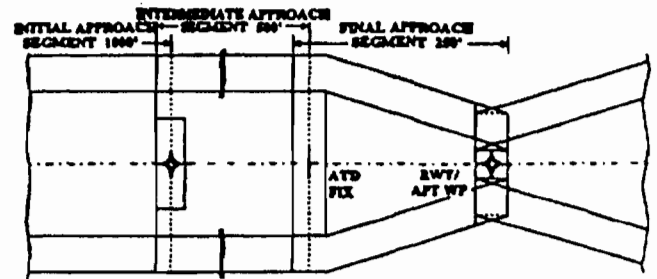

Figure 15-16. INITIAL, INTERMEDIATE, FINAL APPROACH, AND ASSOCIATED ROC.
Par 1521, 1523.

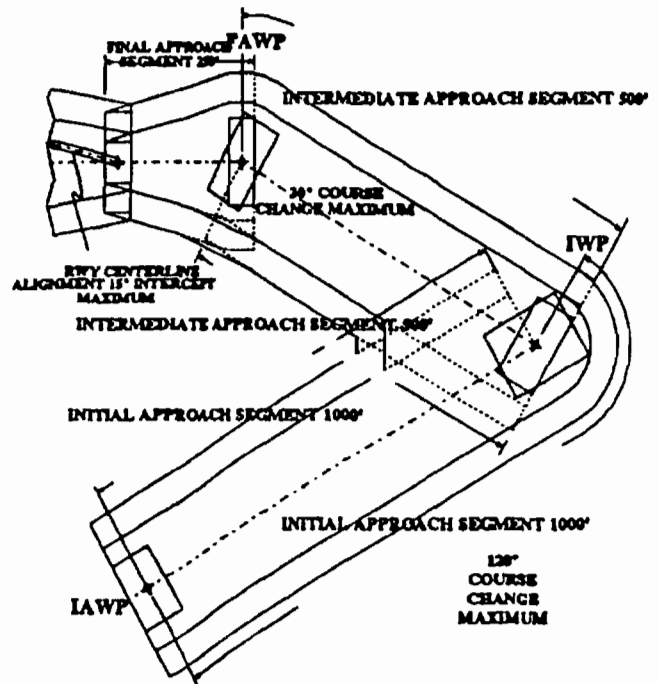

Figure 15-17. INITIAL, INTERMEDIATE, FINAL APPROACH, AND ASSOCIATED ROC.
Par 1521, 1522.

(2) **Width.**

(a) **Primary area:**

1 VOR/DME. See figure 15-18.

a In the 8 NM zone, the area is 4 NM on each side of the centerline.

b In the 4 NM zone, the area is 2 NM on each side of the centerline.

g A 30° splay connects the area boundaries, beginning where the route centerline crosses the 4 NM zone and splaying out as the ATD increases until reaching 4 NM each side of the centerline. In addition:

(1) If the splay cuts across a portion of the WP fix displacement area, retain the width of the wider area and directly connect the wider area boundary with the narrower.

(2) If a short segment transits the 4 NM zone from the 8 NM zone and reenters the 8 NM zone, retain the 8 NM zone.

(3) If the initial approach and succeeding segments lie within the 4 NM zone, the 4 NM zone may be used.

(4) Segments shall not be decreased to 2 NM widths and then increased back to 4 NM widths.

(5) The width of the primary area at the earliest point the IAWP can be received is equal to the width at the plotted position.

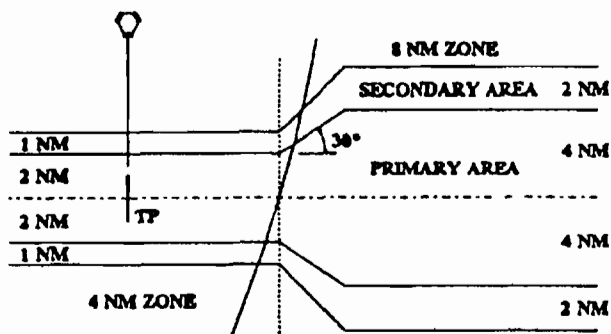

Figure 15-18. VOR/DME BASIC AREA.
Par 1521c(2)(a)1.

2 Non-VOR/DME - 2 miles each side of centerline.

(b) Secondary area:

1 VOR/DME - The area is 1 mile each side of the primary area where the route centerline lies within the 4 NM zone. The area is 2 miles each side of

the primary area where the route centerline lies within the 8 NM zone. The area boundaries are connected by straight lines abeam the same points where the primary area boundaries connect. The width of the secondary area at the earliest point the IAWP can be received is equal to the width at the plotted position.

2 Non-VOR/DME - 1 mile on each side of the primary area.

d. Obstacle Clearance. Paragraph 232c applies.

e. Descent Gradient. Paragraphs 232d and 288a apply.

1522. INTERMEDIATE SEGMENT. The intermediate segment begins at the IWP and ends at the FAWP or ATD fix serving as the FAF. For VOR/DME systems, the distance from the reference facility to the IWP shall not exceed 53 miles nor exceed the TPD or ATD values associated with the limits of the 8 NM zone (see figure 15-2).

a. Alignment. The course to be flown in the intermediate segment should be the same as the FAC. When this is not practical, the intermediate course shall not differ from the FAC by more than 30° and an FAWP shall be established at the turn WP (see figure 15-17).

b. Area.

(1) Length. The intermediate segment shall not be less than 5 miles, nor more than 15 miles in length. If a turn is more than 90° at the IWP, table 3, chapter 2, applies.

(2) Width.

(a) Primary area:

1 VOR/DME - The width of the intermediate primary area shall equal the width of the initial primary area at the IWP. It shall either taper from a point abeam the IWP linearly to ± 2 miles at the FAWP or ATD fix or shall be a constant ± 2 miles, as appropriate. The width at the earliest point the IWP can be received shall equal the width at the plotted position.

2 Non-VOR/DME - 2 miles on each side of centerline.

(b) Secondary area:

1 VOR/DME - The width of the intermediate secondary area shall be equal to the width of the initial secondary area at the IWP and shall either taper from a point abeam the IWP linearly to ± 1 mile at the FAWP or ATD fix or shall be a constant ± 1 mile, as appropriate. The width of the secondary area at the earliest point the IWP can be received shall equal the width at the plotted position.

2 Non-VOR/DME - 1 mile on each side of the primary area.

c. **Obstacle Clearance.** Paragraph 242c applies.

d. **Descent Gradient.** Paragraph 242d applies.

1523. FINAL APPROACH SEGMENT. The final approach segment begins at the FAWP or ATD fix and ends at the MAP. When the FAC is a continuation of the intermediate course, an ATD fix should be used in lieu of a FAWP with additional ATD fixes established, if necessary, as stepdown fixes or the MAP. For VOR/DME systems, the FAWP/ATD fix shall be limited to a TPD of 30 miles or less and must be within the limits of the 4 NM zone shown in figure 15-2.

a. **Alignment.** The FAC shall be aligned through the RWY or APT WP. For a straight-in approach, the alignment should be with the runway centerline. When the alignment exceeds 15° , straight-in minimums are not authorized. For a circling approach, the FAC should be aligned to the center of the landing area, but may be aligned to any portion of the usable landing surface.

b. **Area.** The area considered for obstacle clearance starts at the earliest point of the FAWP or ATD fix displacement area, and for straight-in approaches, ends at the latest point of the RWY WP fix displacement area. For circling approaches, the area ends at the latest point of the APT WP fix displacement area.

(1) **Length.** The optimum length of the final approach segment, measured between plotted fix positions, is 5 miles. The maximum length is 10 miles. The minimum length shall provide adequate distance for an aircraft to make the required descent and to regain course alignment when a turn is required over the FAWP. Table 15-4 shall be used to determine the minimum length of the final approach segment. Fix displacement area overlap restrictions stated in paragraph 1502 apply.

(2) **Width.**

(a) The final approach primary area is centered on the FAC. It is 2 miles wide on each side of

the course at the earliest position the FAWP/ATD fix can be received. See figures 15-15 and 15-16. This width remains constant until the latest point the FAWP/ATD fix can be received. It then tapers to the width of the area of the XTRK fix displacement tolerance at the latest point the RWY WP or APT WP can be received. Fix displacement tolerance dimensions are shown in table 15-2 for VOR/DME systems and in table 15-3 for non-VOR/DME systems.

(b) A secondary area 1 mile wide is established on each side of the primary area (see figures 15-15 and 15-16).

c. **Obstacle Clearance.**

(1) **Straight-In.** The ROC in the primary area is 250 feet. In the secondary area, the ROC of the primary area is provided at the inner edge, tapering uniformly to zero at the outer edge.

(2) **Circling.** A minimum of 300 feet of ROC shall be provided in the circling approach area. Paragraph 260b applies.

d. **Descent Gradient.** Paragraph 252 applies.

e. **Using Fixes for Descent.** Paragraphs 288a, b, c(3), c(4)(a), and 289 apply.

f. **RNAV Descent Angle Information.** Paragraph 252 applies.

Figure 15-19 RESERVED

1524.-1529. RESERVED.

SECTION 3. MISSED APPROACH.

1530. GENERAL. For general criteria, refer to chapter 2, section 7. In the secondary areas, no obstacle may penetrate the 12:1 surface extending upward and outward from the 40:1 surface at the edge of the inner boundaries at a right angle to the missed approach course.

1531. MISSED APPROACH SEGMENT. The missed approach segment begins at the MAP and ends at a point designated by the clearance limit. These criteria consider two types of missed approaches. They are identified as RNAV and non-RNAV MAP's and defined as follows:

a. **RNAV.**

(1) **Route.** PCG provided by RNAV systems is required throughout the missed approach segment. The length of the segment is measured point-to-point between the respective (plotted position) WP's throughout the missed approach procedure.

(a) A WP is required at the MAP and at the end of the missed approach procedure. A turn WP may be included in the missed approach.

(b) A straight, turning, or combination straight and turning missed approach procedure may be developed. WP's are required for each segment within the missed approach procedure.

(c) Turns shall not exceed 120°.

(d) A minimum leg length is required to allow the aircraft's stabilization on course immediately after the MAP. See table 15-6 for minimum distances required for each category of aircraft based on course changes.

(e) For the combination straight and turning missed approach, the distance between the latest point the MAP can be received and the earliest point the turn WP can be received shall be sufficient to contain the length of turn anticipation distance required. This segment shall be aligned within 15° or less of the extended FAC.

(2) **Direct.** A direct missed approach may be developed to provide a method to allow the pilot to proceed to a WP that is not connected to the MAP by a specified course. PCG is not assumed during the entire missed approach procedure.

(a) An ATD fix may be specified as the MAP.

(b) A straight, turning, or combination straight and turning missed approach may be developed.

(c) The combination straight and turning missed approach procedure shall be a climb from the MAP to a specified altitude. The end of the straight section shall be established by an altitude, and this

segment shall be aligned with the FAC. The length of the straight section shall be determined by subtracting the lowest MDA of the procedure from the height of the turning altitude in the missed approach and multiplying by 40. The distance is measured from the latest point the MAP can be received.

(d) Turns may exceed angles of 120°.

b. Non-RNAV Missed Approach Procedures. Chapter 2, section 7, is applicable for non-RNAV missed approach criteria with the following exceptions: the connection for the missed approach area and the origination points of the 40:1 evaluation obstruction slope at the MAP, and the area for early turns begin at the earliest point the WP or ATD fix can be received. The area connects at the MAP as described in paragraphs 1532, 1533, 1534, and 1535. The tie-backs and evaluations are established and conducted as outlined in this chapter of the RNAV missed approach criteria.

1532. MAP. The MAP shall be located on the FAC and is normally located at the RWY WP or APT WP, as appropriate. It may be designated by an ATD fix defined relative to the distance from the RWY or APT WP. The MAP shall be no further from the FAF than the RWY or APT WP, as appropriate. The area of the MAP ATRK displacement tolerance may overlap the plotted position of the RWY or APT WP. The lateral dimensions for the area of the ATD fix are considered the same as the lateral dimensions of the primary area.

1533. STRAIGHT MISSED APPROACH. Straight missed approach criteria are applied when the missed approach course does not differ more than 15° from the FAC.

a. Area.

(1) When the MAP is at the RWY WP or APT WP, the area starts at the earliest point the MAP can be received and has the same width as the area for the WP displacement tolerance at the RWY WP or APT WP, as appropriate. The secondary areas are 1 mile each side of the primary area at the earliest point the MAP can be received (see figure 15-20).

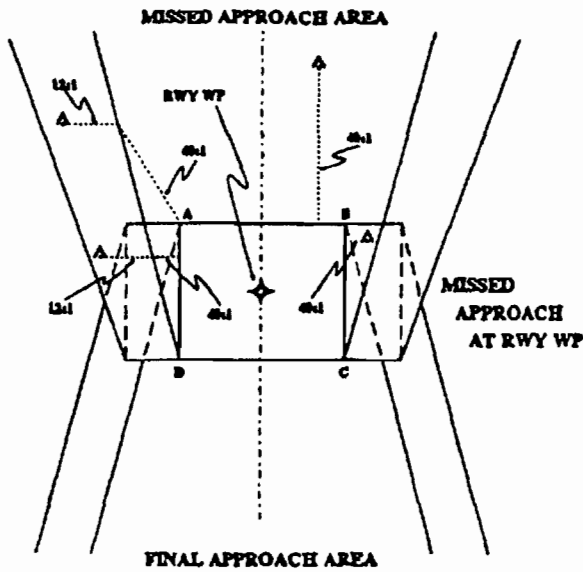

Figure 15-20. STRAIGHT MISSED APPROACH AT THE RWY WP. Par 1533a(1).

(2) When the MAP is at an ATD fix, the area starts at the earliest point the MAP can be received and has the same width as the final approach primary and secondary areas at that point (see figure 15-21).

(3) The area expands uniformly to a width of 6 miles each side of the course line at a point 15 flight-track miles from the plotted position of the MAP. When PCG is provided, the secondary areas splay linearly from a width of 1 mile at the MAP to a width of 2 miles at the end of the 15-mile area. The splay of these areas begins at the earliest point the MAP can be received.

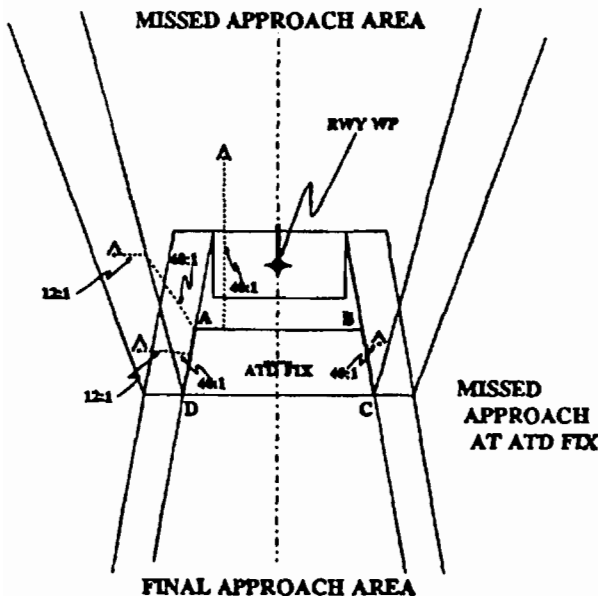

Figure 15-21. STRAIGHT MISSED APPROACH AT AN ATD FIX. Par 1533a(2).

(4) When a turn of 15° or less causes the outside edge of the primary missed approach boundary to cross inside the lateral dimensions of the fix displacement area of the MAP, that boundary line is then constructed from the corner of the lateral dimension of the area abeam the latest point the MAP can be received. This point is identified as point A at the MAP when represented by a WP or an ATD fix is established as the MAP. See figures 15-22 and 15-23, respectively.

b. Obstacle Clearance. The 40:1 missed approach surface begins at the edge of the area of the WP displacement tolerance or the displacement area of the ATD fix of the MAP identified as the line D-A-B-C in figures 15-20 and 15-21. For the triangular area shaded in figures 15-22 and 15-23 resulting from a skewed course of 15° or less, the 12:1 slope is measured from point A. The obstacle slope is established by measuring the shortest distance from the line D-A-B-C to the obstacle (see figures 15-22 and 15-23). The height of the missed approach surface at its beginning slope is determined by subtracting the required final approach obstacle clearance and adjustments specified in paragraph 323 from the MDA.

Policy
Memo
Dec 28
2007

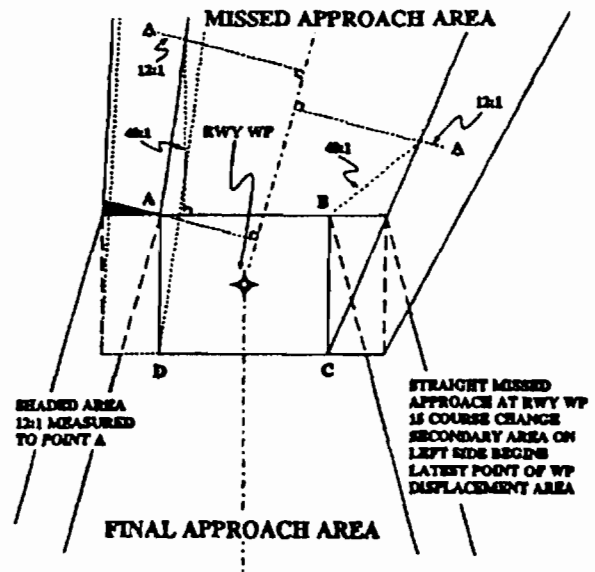

Figure 15-22. CONSTRUCTION OF STRAIGHT MISSED APPROACH WHEN TURNS $\leq 15^\circ$ CAUSE OUTSIDE BOUNDARY TO CROSS INSIDE MAP FIX DISPLACEMENT TOLERANCE AT RWY WP. Par 1533a(4).

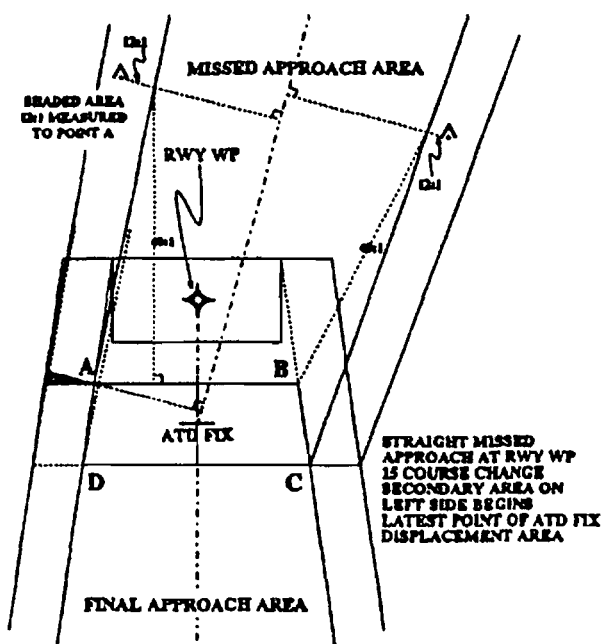

Figure 15-23. CONSTRUCTION OF STRAIGHT MISSED APPROACH WHEN TURNS $\leq 15^\circ$ CAUSE OUTSIDE BOUNDARY TO CROSS INSIDE MAP FIX DISPLACEMENT TOLERANCE AT AN ATD FIX.
Par 1533a(4).

1534. TURNING MISSED APPROACH. Turning missed approach criteria apply whenever the missed approach course differs by more than 15° from the FAC.

a. Area.

(1) Zone 1 begins at a point abeam the latest point the MAP can be received (see figure 15-24).

(2) The turning missed approach area should be constructed by the methods described in paragraph 275, except as follows:

(a) The radii for the outer boundary is constructed from a baseline at the latest point the MAP can be received.

(b) Where the width "d" of the final approach area at the latest point the MAP can be received exceeds

the value of the radius of the outer boundary R in table 5, use "wide final approach area at the MAP" construction methodology. If the width "d" is less than or equal to R, use "narrow" methodology (see figure 15-24). Point C₁, for turns of 90° or less, connects to the WP or fix displacement area at point C, which is located at the earliest point the MAP can be received. See figures 15-25 and 15-27. Point C₁, for turns more than 90° , connects to the corner of the WP or fix displacement area at the nonturn side at point D at the earliest point the MAP can be received. See figures 15-26 and 15-28. Point C₁, for turns which expand the missed approach area boundary beyond line E-D-Z, connects to point E (see figure 15-29). Point C₁, for turns which expand the missed approach area boundary beyond line E-Z (parallel to the FAC line), connects to point E₁, a TP of the obstacle boundary arc (see figure 15-30).

b. Obstacle Clearance. The 40:1 obstacle clearance surface begins at the edge of the WP or fix displacement area of the MAP. The height of the missed approach surface over an obstacle in zone 2 is determined by measuring a straight-line distance from the obstacle to the nearest point on the A-B-C line and computing the height based on the 40:1 ratio (see figure 15-26). The height of the missed approach surface in zone 3 is determined by measuring the distance from the obstacle to point C, as shown in figure 15-26, and computing the height based on the 40:1 ratio. The height of the missed approach surface over point C for zone 3 computations is the same height as the MDA, less adjustments specified in paragraph 323.

1535. COMBINATION STRAIGHT AND TURNING MISSED APPROACH.

a. Area.

(1) Section 1 is a portion of the normal straight missed approach area and is constructed as specified in paragraph 15-33 (see figure 15-31). The end of section 1 is based on a turn at a WP, or a climb to an altitude prior to commencing a turn.

(2) **RNAV Route Missed Approach Procedure.** A turn WP is used to base the length of section 1 for a route RNAV MAP.

Policy
Memo
Dec 28
2007

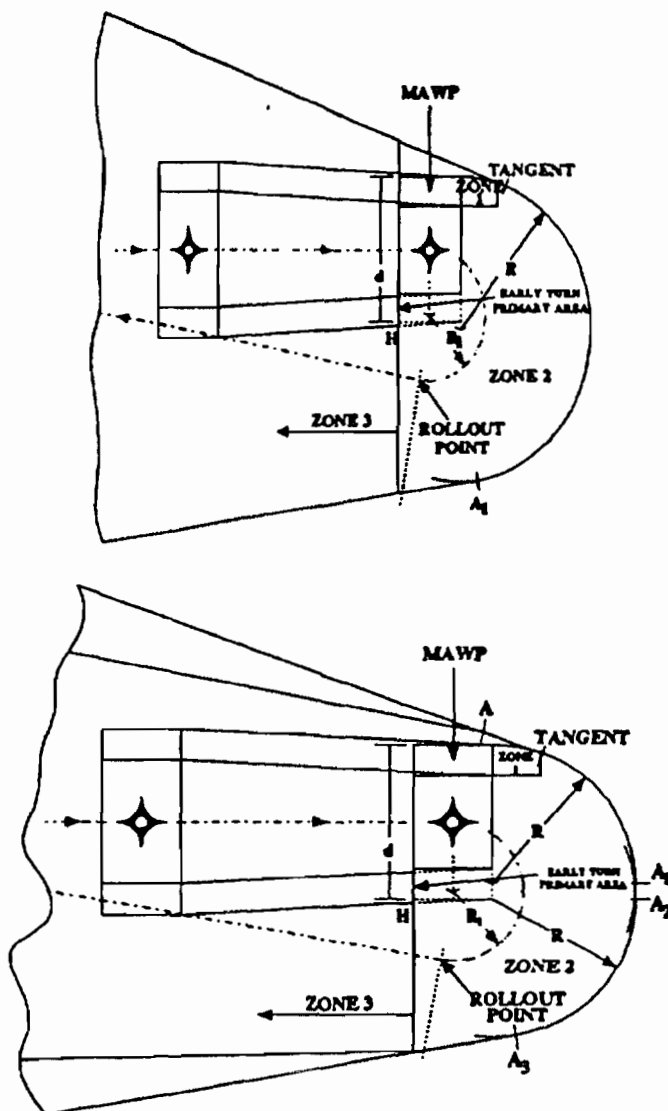

Figure 15-24. WIDE AND NARROW MISSED APPROACH METHODOLOGY.
Par 1534a(1) and (2)

(a) Secondary area reductions apply except where the turn exceeds 90° , when the reduction applies only on the nonturning side. See figure 15-32.

(b) For VOR/DME systems, the turn WP shall be limited to a TPD of 30 NM or less and to within the 4 NM zone.

(c) A turn anticipation area shall be constructed at the turn point.

(d) Construction.

1 Points F, T₁, T₂, and J represent the end of section 1. For turns 90° or less, point C₁

connects to point J. See figure 15-31. For turns of more than 90° , point C₁ of section 3 connects to point T₂. (see figure 15-32).

2 The radius for the obstruction boundary is measured from a base line at the latest point the turn WP can be received.

3 The outer boundary line connects tangentially to the outside radius of the boundary arc. Then, the secondary area boundary connects to that line at the point abeam the plotted position of the turn WP. (see figures 15-31 and 15-32).

(3) RNAV Direct Procedure. For an RNAV direct missed approach, the end of section 1 is based on a climb to altitude, and secondary area reductions are not applied.

(a) The end of section 1 is established as described in paragraph 1531a(2)(c). PCG is not assumed, and secondary area obstruction clearance may not be applied. The end of section 1 is represented by line H-T₃ (see figure 15-33).

(b) Construction.

1 A base line extension of line G-D-C separates sections 2 and 3. When point C₁ is established prior to the base line, C₁ connects to point C (see figure 15-33).

2 When C₁ is established beyond the base line, but inside line G-Z, C₁ connects to point G. G-Z is established parallel to the FAC line (see figure 15-34).

3 When point C₁ is established beyond an area of line G-Z, C₁ connects to point H (see figure 15-35).

4 When point C₁ is established beyond an area of line H-Z, C₁ connects to point K, a tangent point on the boundary arc. H-Z is established parallel to the FAC line (see figure 15-36).

b. Obstruction Clearance.

(1) RNAV route missed approach of turns 90° or less.

(a) Obstacles in section 2 are evaluated based on the shortest distance in the primary area from the obstacle to any point on line T₂-T₃ (see figure 15-31).

(b) Obstacles in section 2b are evaluated based on the shortest distance in the primary area from the obstacle to point T₃ through point J (see figure 15-31).

(2) RNAV Route Missed Approach of Turns More than 90°. Obstacles in sections 2 and 3 are evaluated based on the shortest distance in the primary area from the obstacle to any point on line T₂-T₃ (see figure 15-32).

(3) RNAV Direct Procedure. Obstacles in section 2 are evaluated based on the shortest distance from the obstacle to any point on line G-H-T₃-X. Obstacles in section 3 are evaluated based on shortest distance from the obstacle to point X (see figure 15-36).

(4) The height of the missed approach surface over an obstacle in sections 2 or 3 is determined by measuring the shortest distance from the obstacle to the nearest point on the T₂-T₃ line for RNAV routes missed approach procedures and to the nearest point on the H-T₃ line for RNAV direct missed approach procedures. Compute the height of the surface by using the 40:1 ratio from the height of the missed approach obstacle surface at the end of section 1. The height of the obstacle surface at the end of section 1 is determined by computing the 40:1 obstacle surface slope beginning at the height of the missed approach surface measured from the latest point of the MAP (see figures 15-32 and 15-36).

(5) The height of the missed approach surface over point X for section 3 computations is the height of MDA less adjustments in paragraph 323a, b, and c, plus a 40:1 rise in section 1 as measured from line A-B to end of section 1.

1536. CLEARANCE LIMIT. The missed approach procedure shall specify an appropriate fix as a clearance limit. The fix shall be suitable for holding. For VOR/DME systems, the clearance limit WP's shall meet terminal fix displacement tolerance criteria from table 15-1. For non-VOR/DME systems, clearance limit WP's shall meet en route fix displacement tolerance criteria from table 15-3.

1537.-1539. RESERVED.

SECTION 4. APPROACH MINIMUMS.

1540. APPROACH MINIMUMS. Chapter 3, section 3, applies except that table 6A criteria relating minimum visibility to a distance from the station shall be applied as a variation of XTRK fix displacement tolerance of the

plotted position of the MAP shown in table 15-5. XTRK values in table 15-2 shall be applied for VOR/DME. An XTRK value of 0.6 NM shall be applied for non-VOR/DME.

1541.-1599. RESERVED.

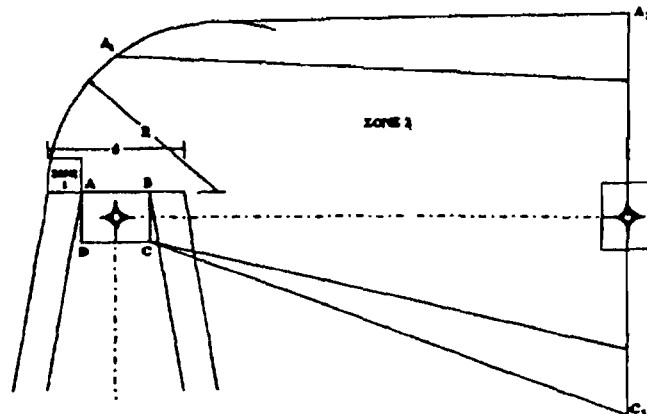

Figure 15-25. RNAV TURNING MISSED APPROACH, 90° OR LESS.
Par 1534a(2)(b).

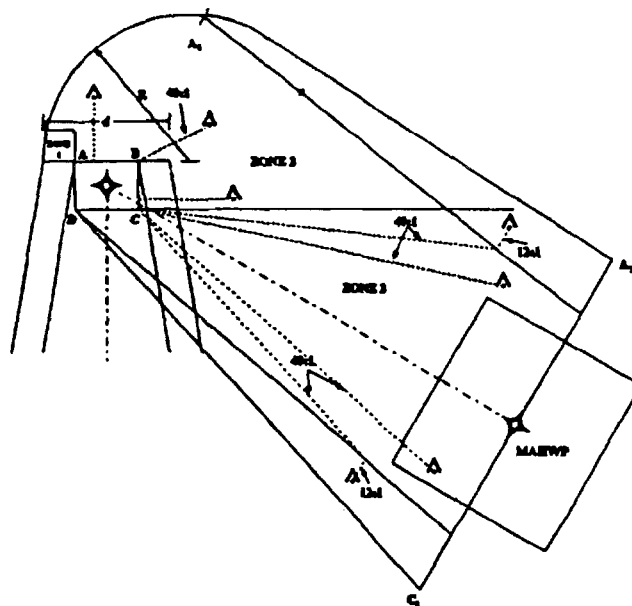

Figure 15-26. RNAV TURNING MISSED APPROACH, MORE THAN 90° UP TO 120°. Par 1534a(2)(b).

Policy
Memo
Dec 28
2007

Policy
Memo
Dec 28
2007

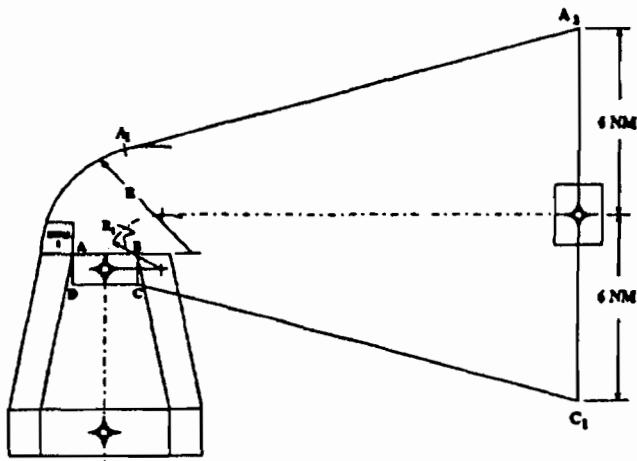
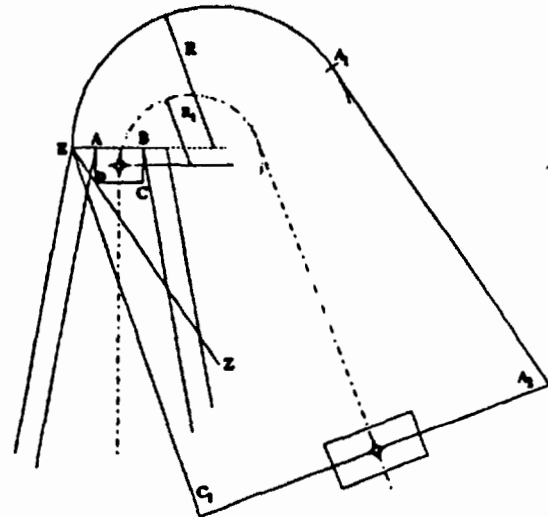

Figure 15-27. DIRECT TURNING MISSED APPROACH, $\leq 90^\circ$ TIE-BACK POINT C_1 TO POINT C. Par 1534a(2)(b).



NOTE: Point C_1 connects to point E when C_1-E is outside of line $E-Z$. $E-Z$ is established by drawing an extended line through D and E.

Figure 15-29. DIRECT TURNING MISSED APPROACH, $> 90^\circ$. Par 1534a(2)(b).

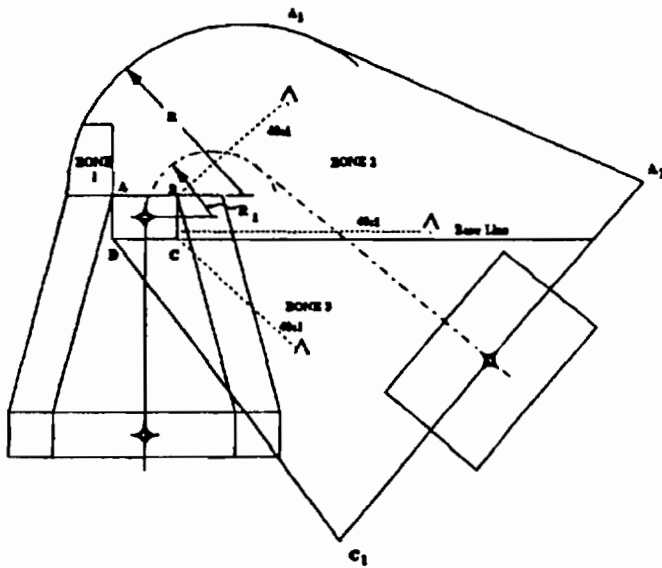
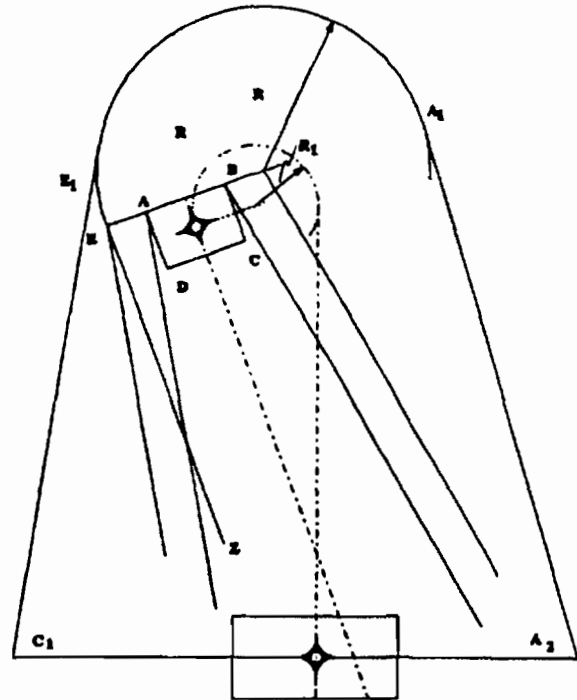

Figure 15-28. DIRECT TURNING MISSED APPROACH, $> 90^\circ$ TIE-BACK POINT C_1 TO POINT D. Par 1534a(2)(b).



NOTE: Point C_1 connects to E_1 tangent to arc when line C_1-E_1 is outside of line $E-Z$. $E-Z$ is established parallel to final approach course line.

Figure 15-30. DIRECT TURNING MISSED APPROACH $> 180^\circ$. Par 1534a(2)(b).

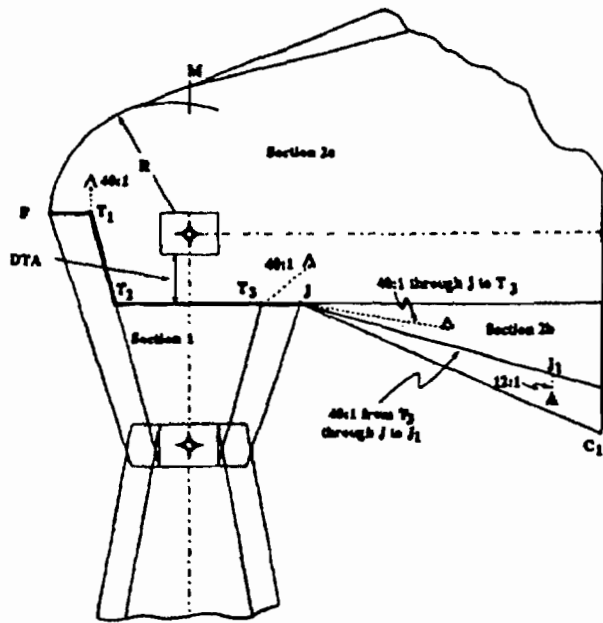

Figure 15-31. RNAV COMBINATION STRAIGHT AND TURNING MISSED APPROACH 90° TURN OR LESS. Par 1535a(2) and 1535b(1)(b).

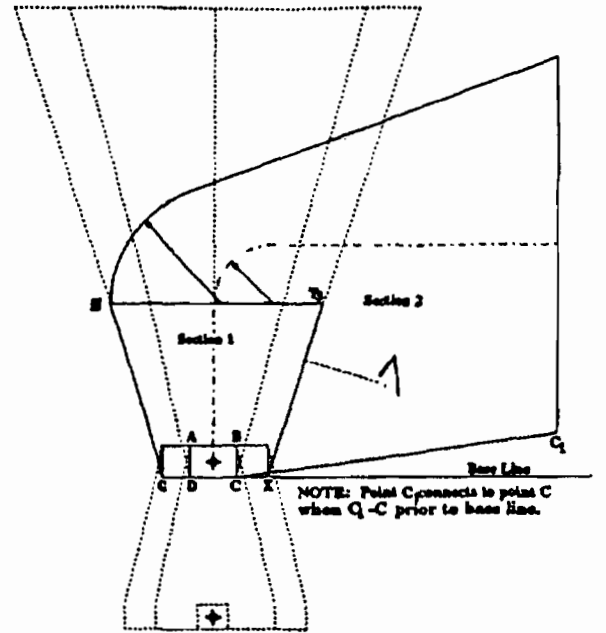

Figure 15-33. CLIMB TO ALTITUDE, STRAIGHT AND TURNING MISSED APPROACH, C₁ PRIOR TO BASE LINE. Par 1535a(3).

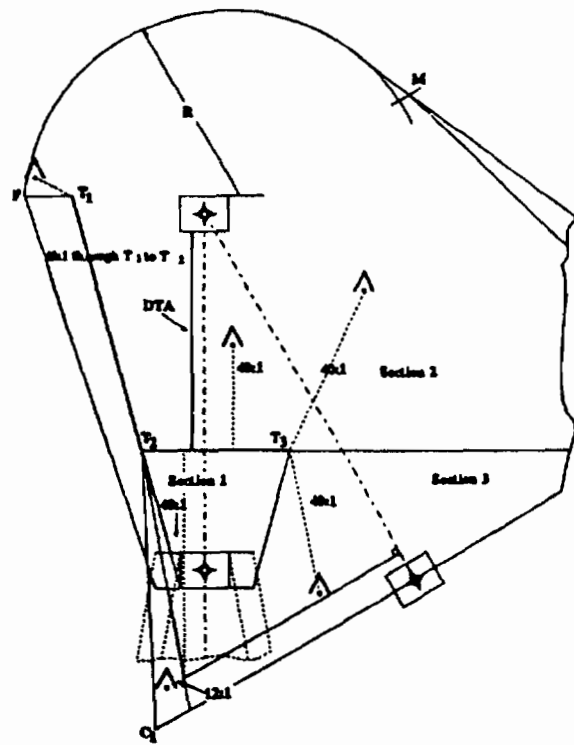

Figure 15-32. RNAV COMBINATION STRAIGHT AND TURNING MISSED APPROACH MORE THAN 90° UP TO 120°. Par 1535a(2) and b(3).

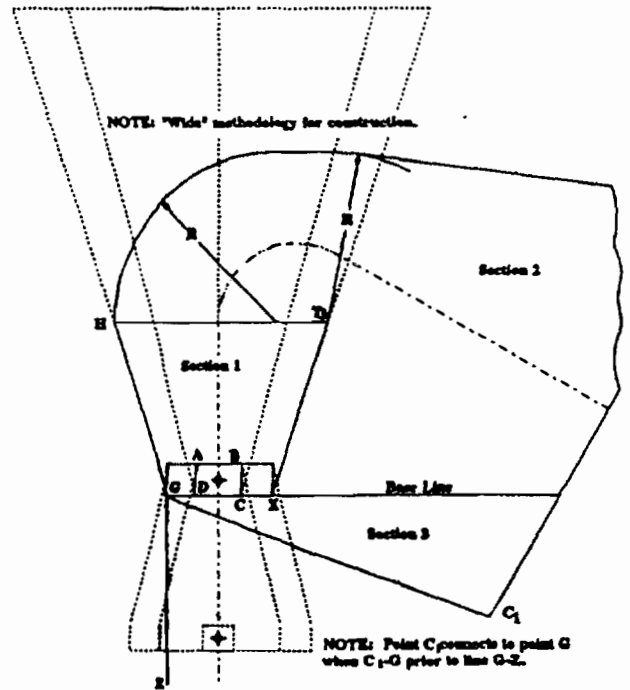

Figure 15-34. CLIMB TO ALTITUDE, STRAIGHT AND TURNING MISSED APPROACH > 90°. Par 1535a(3).

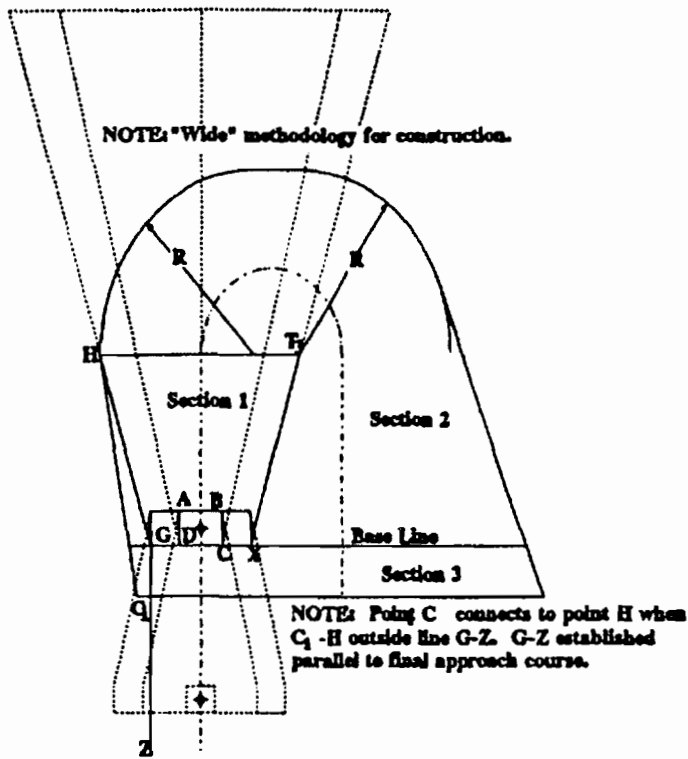

Figure 15-35. CLIMB TO ALTITUDE, STRAIGHT AND TURNING MISSED APPROACH > 90°. Par 1535a(3).

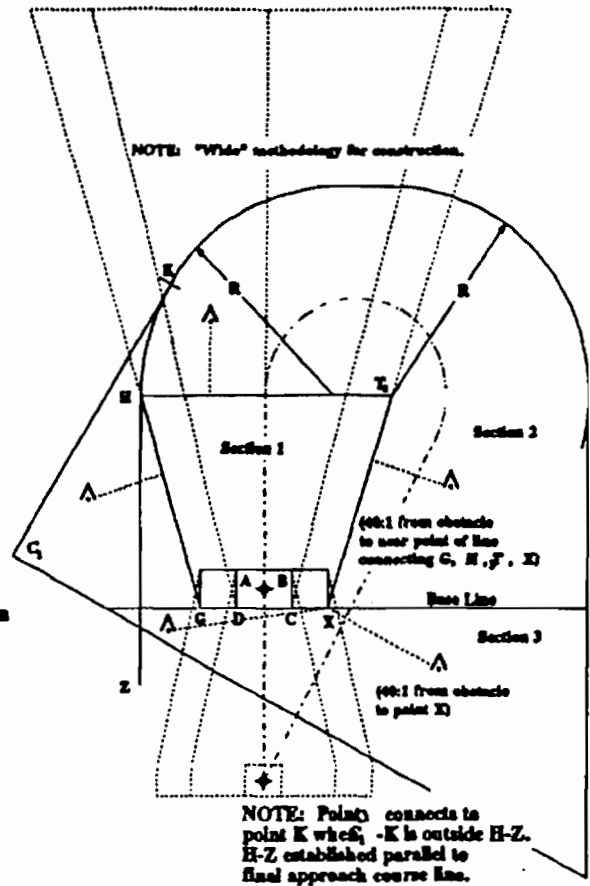

Figure 15-36. CLIMB TO ALTITUDE, STRAIGHT AND TURNING MISSED APPROACH > 180°. Par 1535a(3).

Table 15-1. VOR/DME EN ROUTE AND TERMINAL FIX DISPLACEMENT TOLERANCE

FIX DISTANCE ALONGTRACK FROM TANGENT POINT

		0	10	20	30	40	50	51
DISTANCE FROM TANGENT POINT TO VOR/DME	0	XTRK	13	17	22	28	34	39
		ATRK	08	08	07	08	09	09
	10	XTRK	12	13	17	22	28	34
		ATRK	08	08	09	09	10	11
	20	XTRK	12	14	18	23	28	
		ATRK	13	13	13	14	14	
	30	XTRK	12	14	18	23	29	
		ATRK	18	18	19	19	20	
	40	XTRK	13	15	18	23		
		ATRK	24	24	24	24		
	50	XTRK	13	15				
		ATRK	29	30				
53	XTRK	13						
	ATRK	31						
Terminal								

		0	10	20	30	40	50	
0	XTRK	13	17	22	28		34	
	ATRK	08	08	07	08		09	
10	XTRK	12	13	17	22	28	34	
	ATRK	08	08	09	09	10	11	
20	XTRK	12	14	18	23	28	34	
	ATRK	13	13	13	14	14	15	
30	XTRK	12	14	18	23	29	35	
	ATRK	18	18	19	19	20	20	
40	XTRK	13	15	18	23	29	35	
	ATRK	24	24	24	24	25	25	
50	XTRK	13	15	19	24	29	35	
	ATRK	29	30	30	30	30	31	
60	XTRK	14	16	19	24	30	36	
	ATRK	35	35	35	36	38	38	
70	XTRK	14	16	20	25	30	36	
	ATRK	41	41	41	41	42	42	
J/V En Route								
80	XTRK	15	17	21	25	31	36	
	ATRK	46	47	47	47	47	48	
90	XTRK	16	18	21	26	31	37	
	ATRK	52	52	53	53	53	53	
100	XTRK	17	18	22	26	32	37	
	ATRK	58	58	58	59	59	59	
110	XTRK	17	19	22	27	32	38	
	ATRK	64	64	64	64	65	65	
120	XTRK	18	20	23	28	33	38	
	ATRK	69	70	70	70	70	71	
Random En Route								

Table may be interpolated -- or use next higher value.
XTRK/ATRK values are 2

Table application per segment

Segment	Table 15-1		
	J/V En Route	Random En Route	Terminal
En Route	X		
Feeder		X	
Feeder S/D		X	
LAWP			X
Initial S/D			X
IFP			X
Intermediate S/D			X
MA/Holding			X

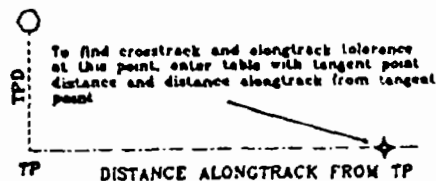

Table 15-2. FINAL/MISSED AREA FIX DISPLACEMENT TOLERANCE.

FIX DISTANCE ALONGTRACK FROM TANGENT POINT

		0	1	2	3	4	5	10	15	20	25	30
TANGENT POINT DISTANCE (TPD) FINAL/MISSED	0 XTRK		0.7	0.7	0.7	0.8	0.8	1.0	1.2	1.5	1.8	2.1
	ATRK		0.6	0.6	0.6	0.6	0.6	0.6	0.6	0.6	0.7	0.7
	1 XTRK	0.7	0.7	0.7	0.7	0.8	0.8	1.0	1.2	1.5	1.8	2.1
	ATRK	0.5	0.5	0.5	0.6	0.6	0.6	0.6	0.6	0.7	0.7	0.7
	2 XTRK	0.7	0.7	0.7	0.7	0.8	0.8	1.0	1.2	1.5	1.8	2.1
	ATRK	0.5	0.5	0.5	0.6	0.6	0.6	0.6	0.6	0.7	0.7	0.7
	3 XTRK	0.7	0.7	0.8	0.8	0.8	0.8	1.0	1.2	1.5	1.8	2.1
	ATRK	0.5	0.5	0.5	0.6	0.6	0.6	0.6	0.6	0.7	0.7	0.7
	4 XTRK	0.8	0.8	0.8	0.8	0.8	0.8	1.0	1.2	1.5	1.8	2.1
	ATRK	0.6	0.6	0.6	0.6	0.6	0.6	0.6	0.7	0.7	0.7	0.8
	5 XTRK	0.8	0.8	0.8	0.8	0.8	0.8	1.0	1.2	1.5	1.8	2.1
	ATRK	0.6	0.6	0.6	0.6	0.6	0.6	0.7	0.7	0.7	0.8	0.8
10 XTRK	0.8	0.8	0.8	0.8	0.8	0.8	1.0	1.2	1.5	1.8	2.1	
ATRK	0.8	0.8	0.8	0.8	0.8	0.8	0.8	0.8	0.9	0.9	0.9	
15 XTRK	0.8	0.8	0.8	0.8	0.8	0.9	1.0	1.2	1.5	1.8	2.1	
ATRK	1.0	1.0	1.0	1.0	1.0	1.0	1.0	1.1	1.1	1.1	1.2	
20 XTRK	0.8	0.8	0.8	0.8	0.9	0.9	1.0	1.3	1.5	1.8	2.1	
ATRK	1.3	1.3	1.3	1.3	1.3	1.3	1.3	1.3	1.3	1.4	1.4	
25 XTRK	0.8	0.9	0.9	0.9	0.9	0.9	1.1	1.3	1.6	1.8	2.1	
ATRK	1.5	1.5	1.5	1.5	1.5	1.5	1.6	1.6	1.6	1.6	1.6	
30 XTRK	0.9	0.9	0.9	0.9	0.9	0.9	1.1	1.3	1.6	1.9	2.1	
ATRK	1.8	1.8	1.8	1.8	1.8	1.8	1.8	1.8	1.9	1.9	1.9	

INTERPOLATE TO THE NEAREST 0.1 MILE
XTRK/ATRK values are ±

Table application per segment	
Segment	Table 15-2
En Route	
Feeder	
Feeder S/D	
IAWP	
Initial S/D	
IWP	
Intermediate S/D	
FAWP/ATD Fix	X
Final S/D	X
MAWP/ATD Fix	x
RWY WP/APT WP	X
MA Turn Point	X
MA/Holding	

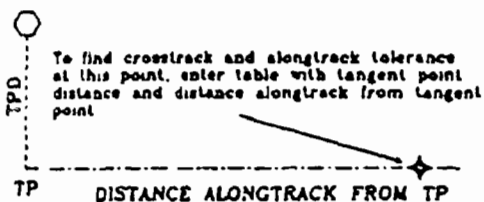

Table 15-3. NON-VOR/DME FIX DISPLACEMENT TOLERANCE.

	EN ROUTE	TERMINAL	APPROACH
XTRK	3.0	2.0	0.6
ATRK	2.8	1.7	0.3

XTRK/ATRK values are ±

Table application per segment

Segment:	En Route	TABLE 15-3 Terminal	Approach
En Route	X		
Feeder	X		
Feeder S/D	X		
IAWP		X	
Initial S/D		X	
IWP		X	
Intermediate S/D		X	
FAWP/ATD Fix			X
Final S/D			X
MAWP/ATD Fix			X
RWY WP/APT WP			X
MA Turn Point			X
MA Holding	X		

Table 15-4. MINIMUM LENGTH OF FINAL APPROACH SEGMENT (NM).

APPROACH CATEGORY	MAGNITUDE OF TURN OVER THE FINAL APPROACH WAYPOINT (FAWP)		
	0°-5°	>5°-10°	>10°-30°
A	1.8	1.8	2.0
B	1.8	2.0	2.5
C	2.0	2.5	3.0
D	2.5	3.0	3.5
E	3.0	3.5	4.0

Table 15-5. EFFECT OF XTRK TOLERANCE ON VISIBILITY MINIMUMS.

CAT	XTRK TOLERANCE (NM)				
	0.6 - 0.8	>0.8 - 1.0	>1.0 - 1.2	>1.2 - 1.6	>1.6
A	1	1	1	1	1
B	1	1	1	1.25	1.25
C	1	1	1.25	1.5	1.5
D	1	1.25	1.5	1.75	2
E	1	1.25	1.5	1.75	2

Table 15-6. MINIMUM LEG LENGTH FROM MAP TO NEXT WP USING RNAV MISSED APPROACH PROCEDURE.

CAT	COURSE CHANGE AT MAP				
	>15° ≤30°	≤45°	≤60°	≤90°	≤120°
	Minimum Leg Length, NM, between MAP and next WP				
A	3.0	4.0	5.0	5.9	6.9
B	3.0	4.0	5.2	6.2	7.2
C	3.0	4.2	5.5	6.5	7.6
D	3.0	4.5	6.0	7.3	8.5
E	3.0	5.5	7.8	9.5	11.3

THIS PAGE INTENTIONALLY LEFT BLANK

CHAPTER 17. ENROUTE CRITERIA

1700.-1709. RESERVED.

Section 1. VHF Obstacle Clearance Areas

1710. ENROUTE OBSTACLE CLEARANCE AREAS. Obstacle clearance areas for enroute planning are identified as "primary," "secondary," and "turning" areas.

1711. PRIMARY AREAS.

a. Basic Area. The primary enroute obstacle clearance area extends from each radio facility on an airway or route to the next facility. It has a width of 8 NM; 4 NM on each side of the centerline of the airway or route. See Figure 17-1.

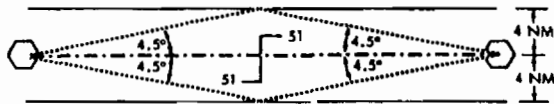

Figure 17-1 PRIMARY OBSTACLE CLEARANCE AREA
Par 1711 a.

b. System Accuracy. System accuracy lines are drawn at a 4.5 degree angle on each side of the course or route. See Figure 17-1. The apexes of the 4.5 degree angles are at the facility. These system accuracy lines will intersect the boundaries of the primary area at a point 50.8 NM from the facility. (Normally 51 NM is used.) If the distance from the facility to the changeover point (COP) is more than 51 NM, the outer boundary of the primary area extends beyond the 4 NM width along the 4.5 degree line. See Figure 17-2. These examples apply when the COP is at midpoint. Paragraph 1716 covers the effect of offset COP or dogleg segments.

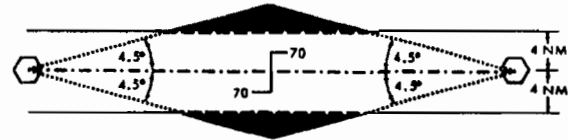

Figure 17-2. PRIMARY OBSTACLE CLEARANCE AREA.
Application of System Accuracy. Par 1711 b.

c. Termination Point. When the airway or route terminates at a navigational facility or other radio fix, the primary area extends beyond that termination point. The boundary of the area may be defined by an arc which connects the two boundary lines. The center of the arc is, in the case of a facility termination point, located at the geographic location of the facility. In the case of a termination at a radial or DME fix, the boundary is formed by an arc with its center located at the most distant point of the fix displacement area on course line. Figure 17-8 and its inset show the construction of the area at the termination point.

1712. SECONDARY AREAS.

a. Basic Area. The secondary obstacle clearance area extends along a line drawn 2 NM on each side of the primary area. See Figure 17-3.

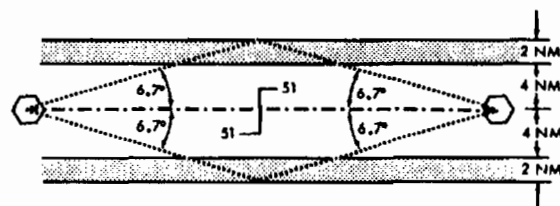

Figure 17-3. SECONDARY OBSTACLE CLEARANCE AREAS.
Par 1712.a.

b. System Accuracy. Secondary area system accuracy lines are drawn at a 6.7 degree angle on

each side of the course or route. See Figure 17-3. The apexes are at the facility. These system accuracy lines will intersect the outer boundaries of the secondary areas at the same point as primary lines, 51 NM from the facility. If the distance from the facility to the COP is more than 51 NM, the secondary area extends along the 6.7 degree line. See Figure 17-4. See paragraph 1716.c. and d. for offset COP or dogleg airway.

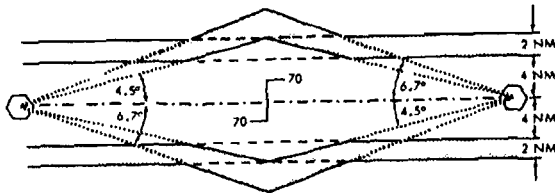

Figure 17-4 SECONDARY OBSTACLE CLEARANCE AREAS.
Application of System Accuracy Lines. Par 1712 b

c. *Termination Point.* Where the airway or route terminates at a facility or radio fix the boundaries are connected by an arc in the same way as those in the primary area. Figure 17-8 and its inset shows termination point secondary areas.

1713. TURNING AREA.

a. *Definition.* The enroute turning area may be defined as an area which may extend the primary and secondary obstacle clearance areas when a change of course is necessary. The dimensions of the primary and secondary areas will provide adequate protection where the aircraft is tracking along a specific radial, but when the pilot executes a turn, the aircraft may go beyond the boundaries of the protected airspace. The turning area criteria supplements the airway and route segment criteria to protect the aircraft in the turn.

b. *Requirement for Turning Area Criteria.* Because of the limitation on aircraft indicated airspeeds below 10,000 feet MSL (FAR 91.70), some conditions do not require the application of turning area airspace criteria.

(1) The graph in Figure 17-5 may be used to determine if the turning area should be plotted for airways/routes below 10,000 feet MSL. If the point of intersection on the graph of the "amount of turn at intersection" versus "VOR facility to intersection distance" falls outside the hatched area of the graph, the turning area criteria need not be applied.

(2) If the "amount of turn" versus "facility distance" values fall within the hatched area or outside the periphery of the graph, then the turning area criteria must be applied as described in paragraph 1714.

c. *Track.* The flight track resulting from a combination of turn delay, inertia, turning rate, and wind effect is represented by a parabolic curve. For ease of application, a radius arc has been developed which can be applied to any scale chart.

d. *Curve Radii.* A 250 knot IAS, which is the maximum allowed below 10,000 feet MSL, results in radii of 2 NM for the primary area and 4 NM for the secondary area up to that altitude. For altitudes above 10,000 feet MSL up to but not including 18,000 feet MSL the primary area radius is 6 NM and the secondary area radius is 8 NM. Above 18,000 feet MSL the radii are 11 NM for primary and 13 NM for secondary.

e. *System Accuracy.* In drawing turning areas it will be necessary to consider system accuracy factors by applying them to the most adverse displacement of the radio fix or airway/route boundaries at which the turn is made. The 4.5 and 6.7 degree factors apply to the VOR radial being flown, but since no pilot or aircraft factors exist in the measurement of an intersecting radial, a navigation facility factor of plus-or-minus 3.6 degrees is used. See Figure 17-6.

NOTE: If a radio fix is formed by intersecting signals from two LF, or one LF and VOR facility, the obstacle clearance areas are based upon accuracy factors of 5.0 (primary) and 7.5 (secondary) degrees each side of the course or route centerlines of the LF facilities. If the VOR radial is the intersecting signal, the 3.6 degree value stated in 1713.e. above applies.

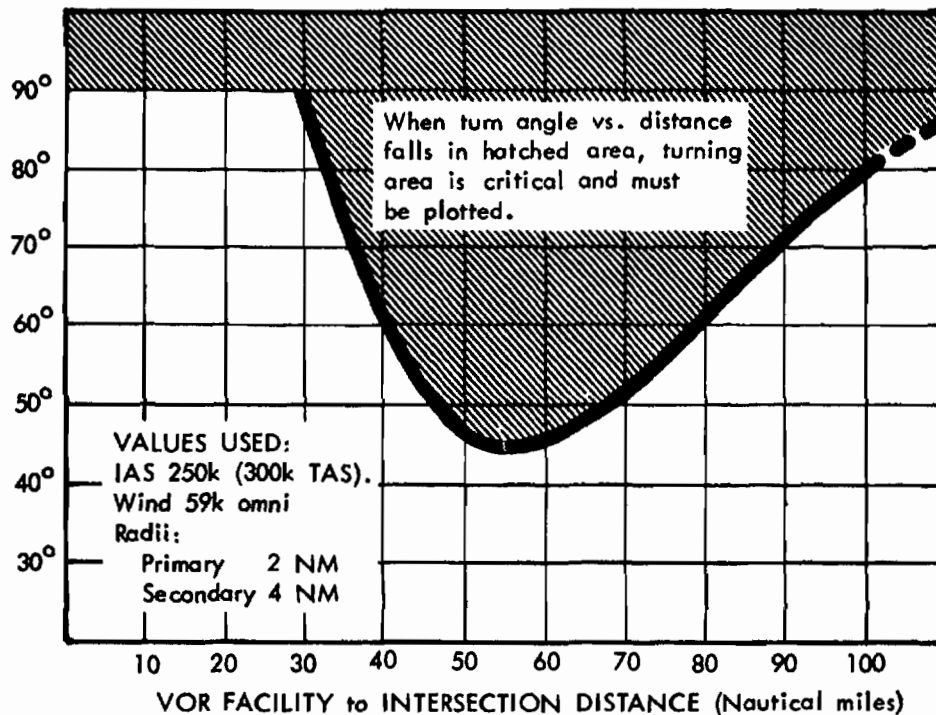

Figure 17-5 TURN ANGLE VS DISTANCE Par 1713 h (1) and (2)

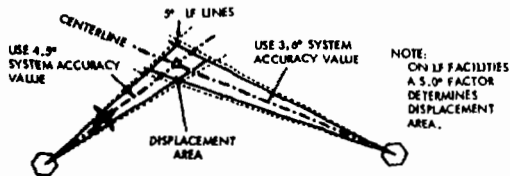

Figure 17-6 FIX DISPLACEMENT Par 1713 e

1714. APPLICATION OF TURNING AREA CRITERIA.

a. *Techniques.* Figures 17-8, 17-9, and 17-10 illustrate the application of the criteria. They also show areas which may be deleted from considerations when obstacle clearance is the deciding factor for establishing minimum enroute altitudes (MEAs) on airways or route segments.

b. *Computations.* Computations due to obstacles actually located in the turning areas will probably be indicated only in a minority of cases. These methods do, however, add to the flexibility of procedures specialists in resolving specific obstacle clearance problems without resorting to the use of waivers.

c. *Minimum Turning Altitude (MTA).* Where the application of the turn criteria obviates the use of an MEA with a cardinal altitude, the use of an MTA for a special direction of flight may be authorized. Where this is employed an appropriate notation shall be included on the FAA Form 8260-2, Radio Fix and Holding Data Record, for the turning fix. *

1715. **TURN AREA TEMPLATE.** A turn area template has been designed for use on charts scaled at 1:500,000. See Figure 17-7. It is identified as "TA-1."

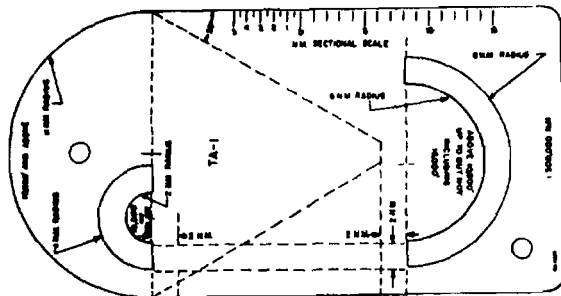

Figure 17-7. TURNING AREA TEMPLATE. Par 1715.

a. Use of Template-Intersection Fix.

(1) **Primary Area.** At an intersection fix the primary obstacle clearance area arc indexes are placed at the most adverse points of the fix displacement area as determined by the outer intersections of the enroute radial 4.5 degree lines (VOR) and the cross-radial 3.6 degree lines (VOR). See Figures 17-8 and 17-9. If LF signals are used the 5.0 degree system accuracy lines apply. The parallel dashed lines on the turn area template are aligned with the appropriate system accuracy lines and the curves are drawn.

(2) **Secondary Area "Outside" Curve.** The outside curve of the secondary turning area is the curve farthest from the navigation facility which provides the intersecting radial. This curve is indexed to the distance from the fix to the enroute facility as follows:

(a) Where the fix is less than 51 NM from the enroute facility, the secondary arc is started at a point 2 NM outside the primary index with the parallel dashed lines of the template aligned on the 4.5 degree line. See Figure 17-8.

(b) Where the fix is farther than 51 NM from the enroute station, the arc is started at the point of intersection of the 3.6 and 6.7 degree lines with the parallel dashed lines of the template aligned on the 6.7 degree line. See Figure 17-9.

(3) **Secondary Area "Inside" Curve.** The inside curve is the turning area arc which is nearest the navigation facility which provides the intersecting radial. This arc is begun 2 NM beyond the primary index and on the 3.6 degree line. The parallel dashed lines on the turning area template are aligned with the 4.5 degree line from the enroute station.

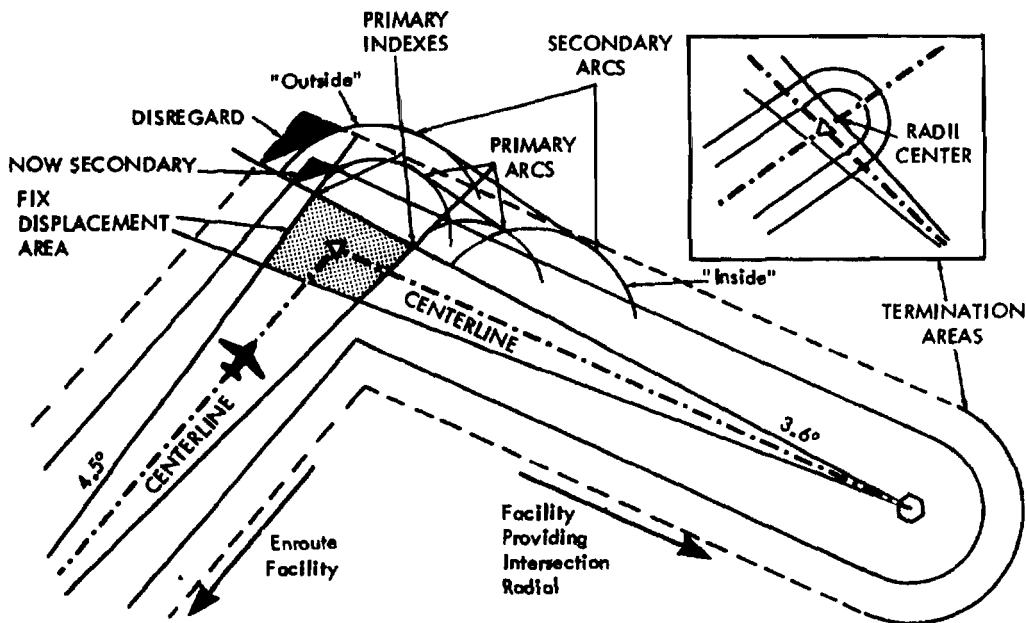

Figure 17-8 TURNING AREA, INTERSECTION FIX (Facility Distance Less than 51 NM) Par 1715 a and b

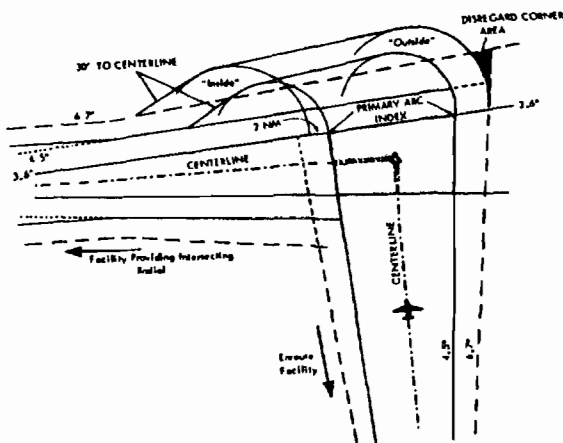

Figure 17-9. TURNING AREA, INTERSECTION FIX
(Facility Distance Beyond 51 NM). Par 1715 a and b

(a) Where the fix is less than 51 NM from the enroute facility and the magnitude of the turn is less than 30 degrees, the "inside" curves do not affect the size of the secondary area.

(b) Where the distance from the enroute facility to the fix is more than 51 NM but the magnitude of the turn is less than 45 degrees, the "inside" curves do not increase the size of the secondary area.

(c) Where the magnitude of the turn is greater than those stipulated in (a) and (b) above, the "inside" curves will affect the size of the secondary area.

(d) Whether the secondary area curves affect the size of the secondary obstacle clearance area or not, they must be drawn to provide reference points for the tangential lines described in (4) below.

(4) **Connecting Lines.** Tangential straight lines are now drawn connecting the two primary arcs and the two secondary arcs. The outer limits of both curves are symmetrically connected to the respective primary and secondary area boundaries in the direction of flight by lines drawn at a 30 degree angle to the airway or route centerline. See Figures 17-8 and 17-9.

b. *Use of Template When Fix Overheads a Facility.* See Figure 17-10. The geographical position of the fix is considered to be displaced laterally and longitudinally by 2 NM at all altitudes.

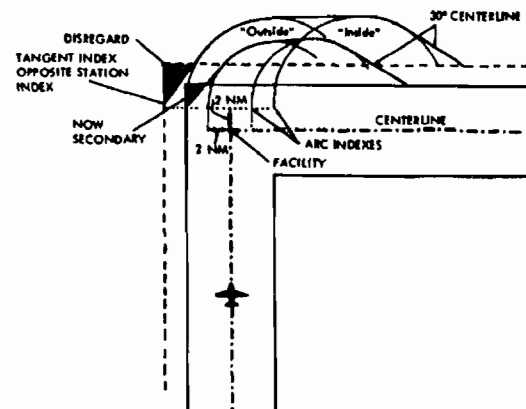

Figure 17-10. TURNING AREA - OVERHEAD THE FACILITY
Par 1715b.

(1) **Primary Arcs.** The primary arcs are indexed at points 2 NM beyond the station and 2 NM on each side of the station. The parallel dotted lines on the template are aligned with the airway or route boundaries and the curves drawn.

(2) **Secondary Arcs.** The secondary arcs are indexed 2 NM outside the primary points, and on a line with them. The parallel dotted lines on the template are aligned with the airway or route boundaries, and the curves drawn.

(3) **Connection Lines.** Tangential straight lines are now drawn connecting the two primary and the two secondary arcs. The outer limits of both curves are connected to the primary and secondary area boundaries by intercept lines which are drawn 30 degrees to the airway or route centerline. The 30 degree lines on the template may be used to draw these intercept lines.

c. *Deletion Areas.* Irregular areas remain on the outer corners of the turn areas. See Figures 17-8, 17-9, and 17-10. These are the areas identified in paragraph 1714 which may be deleted from consideration when obstacle clearance is the deciding factor for determination of MEA on an airway or route segment.

(1) Where the "outside" secondary area curve is started within the airway or route secondary area boundary (see Figure 17-8), the area is blended by drawing a line from the point where the 3.6 degree (5.0 with LF facility) line meets the line which forms the enroute secondary boundary tangent to the "outside" secondary arc. Another line is drawn from the point where the same 3.6 (or 5.0) degree line meets the line which forms the primary boundary, tangent to the matching primary arc. These two lines now enclose the secondary area at the turn. The corner which was formerly part of the secondary area may be disregarded; the part which was formerly part of the primary area may now be considered secondary area. These areas are shaded in Figure 17-8.

(2) Where the secondary curve is indexed on the secondary area boundary formed by the 6.7 degree lines, the arc itself cuts the corner and prescribes the deleted area. See Figure 17-9. This condition occurs when the radio fix is over 51 NM from the enroute navigation facility.

(3) When overheading the facility, the secondary area corner deletion area is established by drawing a line from a point opposite the station index at the secondary area boundary, tangent to the secondary "outside" curve. See Figure 17-10. A similar line is drawn from a point opposite the station index at the primary area boundary, tangent to the primary turning arc. The corner formerly part of the primary area now becomes secondary area. The deletion areas are shown in Figure 17-10 by shading.

1716. CHANGEOVER POINTS (COP). Points have been defined between navigation facilities along airway/route segments which are called "changeover points (COP)." These points indicate that the pilot using the airway/route should "change over" his navigation equipment to receive course guidance from the facility ahead of the aircraft instead of the one behind. These COP divide a segment and assure continuous reception of navigation signals at the prescribed minimum enroute IFR altitude (MEA). They also assure that aircraft operating within the same portion of an airway or route segment will not be using azimuth signals from two different navigation facilities. Where signal coverage from two facilities

overlaps at the MEA, the COP will normally be designated at the midpoint. Where radio frequency interference or other navigation signal problems exist, the COP will be at the optimum location, taking into consideration the signal strength, alignment error, or any other known condition which affects reception. The effect of COP on the primary and secondary obstacle clearance areas is as follows:

a. Short Segments. If the airway or route segment is less than 102 NM long and the COP is placed at the midpoint, the obstacle clearance areas are not affected. See Figure 17-11.

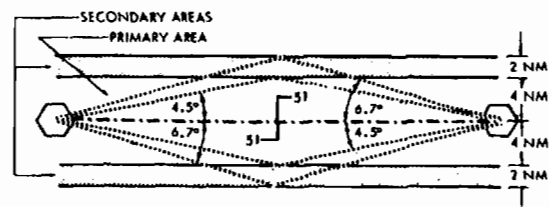

Figure 17-11. COP EFFECT Short Airway or Route Segment Par 1716 a

b. Long Segments. If the distance between two facilities is over 102 NM and the COP is placed at the midpoint, the system accuracy lines extend beyond the minimum widths of 8 and 12 NM, and a flare results at the COP. See Figure 17-12.

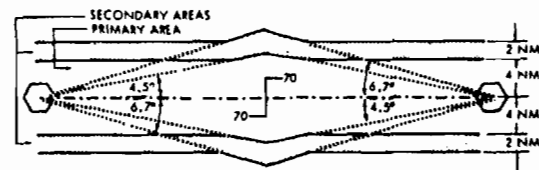

Figure 17-12. COP EFFECT Long Airway or Route Segment Par 1716 b

c. *Offset COP.* If the changeover point is offset due to facility performance problems, the system accuracy lines must be carried from the farthest facility to a position abeam the changeover point, and these lines on each side of the airway or route segment at the COP are joined by lines drawn directly from the nearer facility. In this case the angles of the lines drawn from the nearer facility have no specific angle. See Figure 17-13.

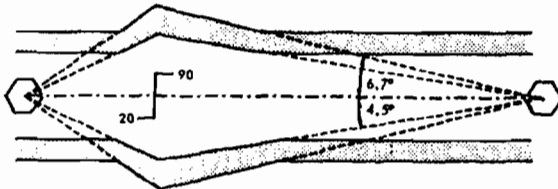

Figure 17-13 OFFSET COP. Par 1718 c

d. *Dogleg Segment.* A dogleg airway or route segment may be treated in a manner similar to that given offset COPs. The system accuracy lines will be drawn to meet at a line drawn as the bisector of the dogleg "bend" angle and the boundaries of the primary and secondary areas extended as required. See Figure 17-14.

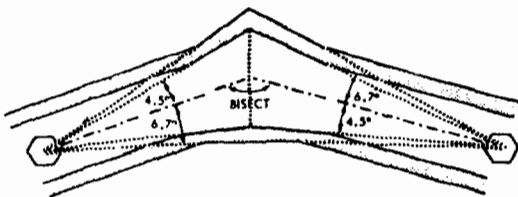

Figure 17-14 DOGLEG SEGMENT. Par 1716 d.

1717. COURSE CHANGE EFFECT. The complexity of defining the obstacle clearance areas is increased when the airway or route becomes more complex. Figure 17-15 shows the method of defining the primary area when a radio fix and a COP are involved. Note that the system accuracy lines are drawn from the farthest facility

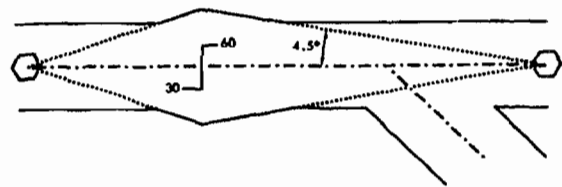

Figure 17-15 COURSE CHANGE EFFECT Par 1717.

first, and govern the width of the airway or route at the COP. The application of secondary area criteria results in a segment similar to that depicted in Figure 17-16.

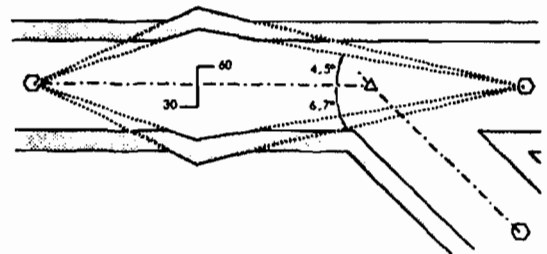

Figure 17-16 APPLICATION OF SECONDARY AREAS Par 1717

1718. MINIMUM ENROUTE INSTRUMENT ALTITUDES (MEA). An MEA will be established for each segment of an airway/route from radio fix to radio fix. The MEA will be established based upon obstacle clearance over the terrain or over manmade objects, adequacy of navigation facility performance, and communications requirements. Segments are designated West to East and South to North. Altitudes will be established to the nearest 100 foot increment; i.e., 2049 feet becomes 2000, and 2050 feet becomes 2100.

NOTE: Care must be taken to insure that all MEAs based upon flight inspection information have been corrected to and reported as true altitudes above mean sea level (MSL).

1719. PROTECTED ENROUTE AREAS. As previously established, the enroute areas which must be considered for obstacle clearance protection are identified as primary, secondary, and turn areas. The overall consideration of these areas is necessary when determining obstacle clearances.

Section 2. VHF Obstacle Clearance

1720. OBSTACLE CLEARANCE, PRIMARY AREA.

a. Nonmountainous Areas. The minimum obstacle clearance over areas NOT designated as mountainous under FAR 95 will be 1000 feet over the highest obstacle.

b. Mountainous Areas. Owing to the action of Bernoulli Effect and of atmospheric eddies, vortices, waves, and other phenomena which occur in conjunction with the disturbed airflow attending the passage of strong winds over mountains, pressure deficiencies manifested as very steep horizontal pressure gradients develop over such regions. Since downdrafts and turbulence are prevalent under these conditions, the hazards to air navigation are multiplied. Except as set forth in (1) and (2) below, the minimum obstacle clearance over terrain and manmade obstacles, within areas designated in FAR 95 as "mountainous" will be 2000 feet.

(1) Obstacle clearance may be reduced to not less than 1500 feet above terrain in the designated mountainous areas of the Eastern United States, Commonwealth of Puerto Rico, and the land areas of the State of Hawaii; and may be reduced to not less than 1700 feet above terrain in the designated mountainous areas of the Western United States and the State of Alaska. Consideration must be given to the following points before any altitudes providing less than 2000 feet of terrain clearance are authorized.

(a) Areas characterized by precipitous terrain.

(b) Weather phenomena peculiar to the area.

(c) Phenomena conducive to marked pressure differentials.

(d) Type of and distance between navigation facilities.

(e) Availability of weather services throughout the area.

(f) Availability and reliability of altimeter resetting points along airways/routes in the area.

(2) Altitudes providing at least 1000 feet of obstacle clearance over towers and/or other manmade obstacles may be authorized within designated mountainous areas provided such obstacles are NOT located on precipitous terrain where Bernoulli Effect is known or suspected to exist.

NOTE: When approving MEAs with less than 2000 feet of obstacle clearance in designated mountainous areas, a record of such approval will be maintained by the Flight Inspection Field Office.

1721. OBSTACLE CLEARANCE, SECONDARY AREAS. In all areas, mountainous and nonmountainous, obstacles which are located in the secondary areas will be considered as obstacles to air navigation when they extend above the secondary obstacle clearance plane. This plane begins at a point 500 feet above the obstacles upon which the primary obstacle clearance area MOCA is based, and slants upward at an angle which will cause it to intersect the outer edge of the secondary area at a point 500 feet higher. See Figure 17-17. Where an obstacle extends above this plane, the normal MOCA shall be increased by adding to the MSL height of the highest penetrating obstacle in the secondary area the required clearance (C), computed with the following formula:

$$\frac{D^1}{D^2} = \frac{500}{C} \text{ or } C = \frac{500 \times D^2}{D^1}$$

D¹ is the total width of the secondary area.

D² is the distance from the obstacle to the OUTER edge of the secondary area.

NOTE: Add an extra 1000 feet in mountainous areas except where MEAs in enroute airspace

areas are reduced under the provisions of paragraph 1720. In these cases, where the primary area MOCA has been reduced to 1700 feet, add 700 feet to the secondary obstacle clearance, and where the primary area MOCA has been reduced to 1500 feet, add 500 feet to the secondary area clearance value.

D¹ has a total width of 2 NM, or 12,152 feet out to a distance of 51 NM from the enroute facility, and then increases at a rate of 236 feet for each additional NM.

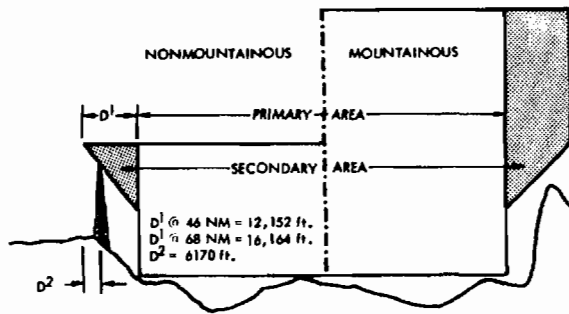

Figure 17-17 CROSS SECTION, SECONDARY AREA OBSTACLE CLEARANCES. Par 1721.

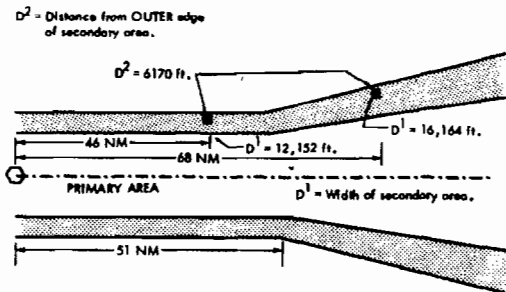

Figure 17-18. PLAN VIEW, SECONDARY AREA OBSTACLE CLEARANCES. Par 1721.

Example: An obstacle which reaches 1875 feet MSL is found in the secondary area 6170 feet inside the outer secondary area boundary and 46 NM from the facility. See Figures 17-17 and 17-18.

D¹ is 12,152 feet.
D² is 6170 feet.

$$\frac{500 \times 6170}{12,152} = 253.8 \text{ (254 feet)}$$

Obstacle height (1875) + 254 = 2129.
MOCA is 2100 feet.

1722. OBSTACLE CLEARANCE GRAPH.

Figure 17-19 is a secondary area obstacle clearance graph, designed to allow the determination of clearance requirements without using the formula. The left axis shows the required obstacle clearance; the lower axis shows the distance from the outer edge of the secondary area to the obstacle. The slant lines are facility distance references.

Facility distances which fall between the charted values may be found by interpolation along the vertical distance lines.

a. Application. To use the secondary area obstacle clearance chart, enter with the value representing the distance from the outer edge of the secondary area to the obstacle. In the problems above this distance was 6170 feet. Proceed up to the "51 NM or less" line and read the clearance requirement from the left axis. The chart reads 254 feet, the same as was found using the formula. To solve the second problem, reenter the chart at 6170 feet and move vertically to find 68 NM between the 60 and 70 NM facility distance slant lines. The clearance requirement shown to the left is 191 feet, the same as found using the formula.

b. Finding the MOCA. The required clearance, found by using the graph, is now added to the MSL height of the obstacle to get the MOCA:

- (1) 46 NM from facility:
254 + 1875 = 2129 (2100 MSL).
- (2) 68 NM from facility:
191 + 1875 = 2066 (2100 MSL).

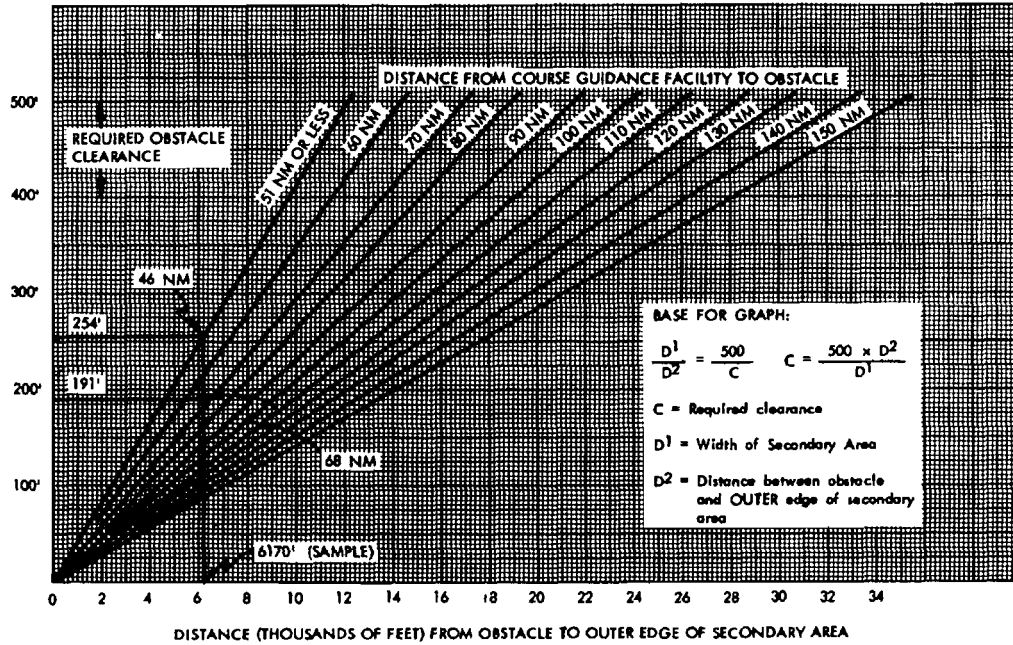

Figure 17-19 SECONDARY AREA OBSTACLE CLEARANCE Par 1722

1723.-1729. RESERVED.

Section 3. Altitudes

1730. MINIMUM CROSSING ALTITUDES (MCA). It is necessary to establish MCAs in all cases where obstacles intervene to prevent a pilot from maintaining obstacle clearance during a normal climb to a higher MEA after the aircraft passes a point beyond which the higher MEA applies. The same vertical obstacle clearance requirement for the primary and secondary areas must be considered in the determination of the MCA. See paragraph 1718. The standard for determining the MCA shall be based upon the following climb rates, and is computed from the flight altitude:

SL through 5000 feet	150 ft/NM
5000 through 10,000 feet	120 ft/NM
10,000 feet and over	100 ft/NM

a. To determine the MCA, the distance from the obstacle to the radio fix shall be computed from the point where the centerline of the en route course in the direction of flight intersects

the farthest displacement from the fix. See Figures 17-20 and 17-21.

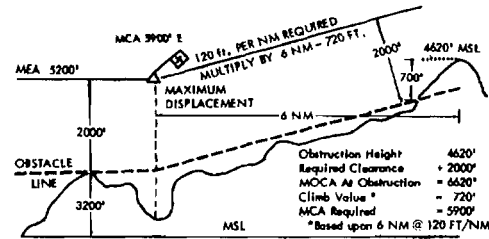

Figure 17-20 MCA DETERMINATION POINT. Par 1730

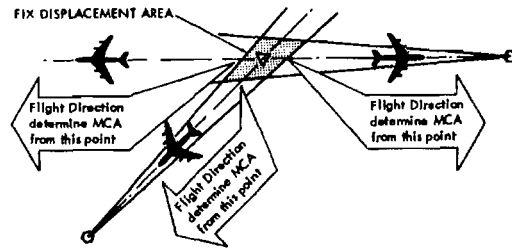

Figure 17-21. DETERMINATION OF MCA Par 1730.

b. When a change of altitudes is involved with a course change, course guidance must be provided if the change of altitude is more than 1,500 feet and/or if the course is more than 45 degrees.

EXCEPTION: Course changes of up to 90 degrees may be approved without course guidance provided that no obstacles penetrate the established MEA requirement of the previous airway/route segment within 15 NM of the boundaries of the system accuracy displacement area of the fix. See figure 17-22 and paragraph 1740b(2).

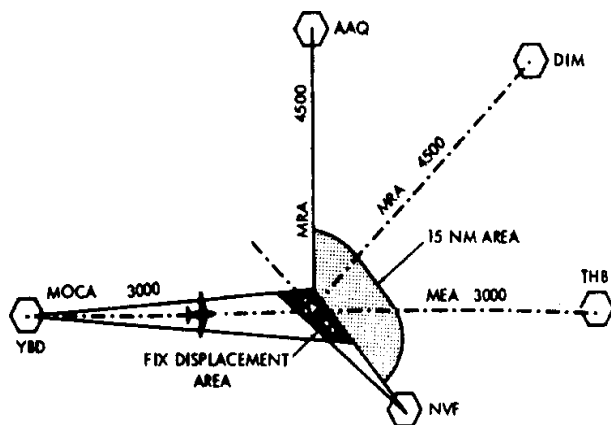

Figure 17-22. MEA WITH NAVIGATION GAP AT TURNING POINT. Par 1740b(2)

1731. EN ROUTE MINIMUM HOLDING ALTITUDES. Criteria for holding pattern airspace are contained in Order 7130.3, Holding Pattern Criteria, and provide for separation of aircraft from aircraft. The criteria contained in this document deal with the clearance of holding aircraft from obstacles.

a. Area. The primary obstacle clearance area for holding shall be based on the appropriate holding pattern airspace area specified in Order 7130.3. No reduction in the pattern sizes for "on entry" procedures is permitted. In addition, when holding at an intersection fix, the selected pattern shall also be large enough to contain at least 3 corners of the fix displacement area. See paragraphs 284, 285, and figure 37-1. A secondary area 2 miles wide surrounds the perimeter of the primary area.

b. Obstacle Clearance. The minimum obstacle clearance of the route shall be provided throughout the primary area. In the secondary area 500 feet of obstacle clearance shall be provided at the INNER edge, tapering to zero feet at the outer edge. For computation of obstacle clearance in the secondary area, the computation formula specified in paragraph 1721 shall be applied. Allowance for precipitous terrain should be considered as stated in paragraph 323a. The altitudes selected by application of the obstacle clearances specified in this paragraph may be rounded to the nearest 100 feet.

c. Communications. The communications on appropriate ATC frequencies (as determined by ATS) shall be required throughout the entire holding pattern area from the MHA up to and including the maximum holding altitude. If the communications are not satisfactory at the minimum holding obstacle clearance altitude, the MHA shall be authorized at an altitude where the communications are satisfactory. For communications to be satisfactory, they must meet the standards as set forth in Order 8200.1, United States Standard Flight Inspection Manual.

d. Holding Patterns On/ Adjacent to ILS Courses. Holding patterns on or adjacent to ILS courses shall comply with Order 7130.3, paragraph 4-7.

e. High Altitude. All holding patterns in the high altitude structure shall be coordinated with the Aviation Systems Standards office prior to being approved.

1732.-1739. RESERVED.

Section 4. Navigational Gaps

1740. NAVIGATIONAL GAP CRITERIA. Where a gap in course guidance exists, an airway or route segment may be approved in accordance with the criteria set forth in paragraph 1740c, provided:

a. Restrictions.

(1) The gap may not exceed a distance which varies directly with altitude from zero NM at sea level to 65 NM at 45,000 feet MSL, and

Policy
Memo
Dec 28
2007

(2) **Not more than one gap** may exist in the airspace structure for the airway/route segment, and

(3) **A gap may not occur** at any airway or route turning point, except when the provisions of paragraph 1740b(2) are applied, and

(4) **A notation must be included** on FAA Form 8260-16 which specifies the area within which a gap exists where the MEA has been established with a gap in navigational signal coverage. The gap area will be identified by distances from the navigation facilities.

b. Authorizations. MEA's with gaps shall be authorized only where a specific operational requirement exists. Where gaps exceed the distance in paragraph 1740a(1), or are in conflict with the limitations in paragraph 1740a(2) or (3), the MEA must be increased as follows:

(1) For straight segments:

(a) To an altitude which will meet the distance requirement of paragraph 1740a(1), or

(b) When in conflict with paragraph 1740a(1) or (2) to an altitude where there is continuous course guidance available.

(2) For turning segments. Turns to intercept radials with higher MEA's may be allowed provided:

(a) The increase in MEA does not exceed 1,500 feet, and

(b) The turn does not exceed 90 degrees, and

(c) No obstacles penetrate the MEA of the course being flown within 15 NM of the fix displacement area (see figure 17-22).

(3) When in conflict with paragraph 1740b(1) or (2) to an altitude where there is continuous course guidance available.

c. Use of Steps. Where large gaps exist which require the establishment of altitudes that obviate the effective use of airspace, consideration may be given to the establishment of MEA

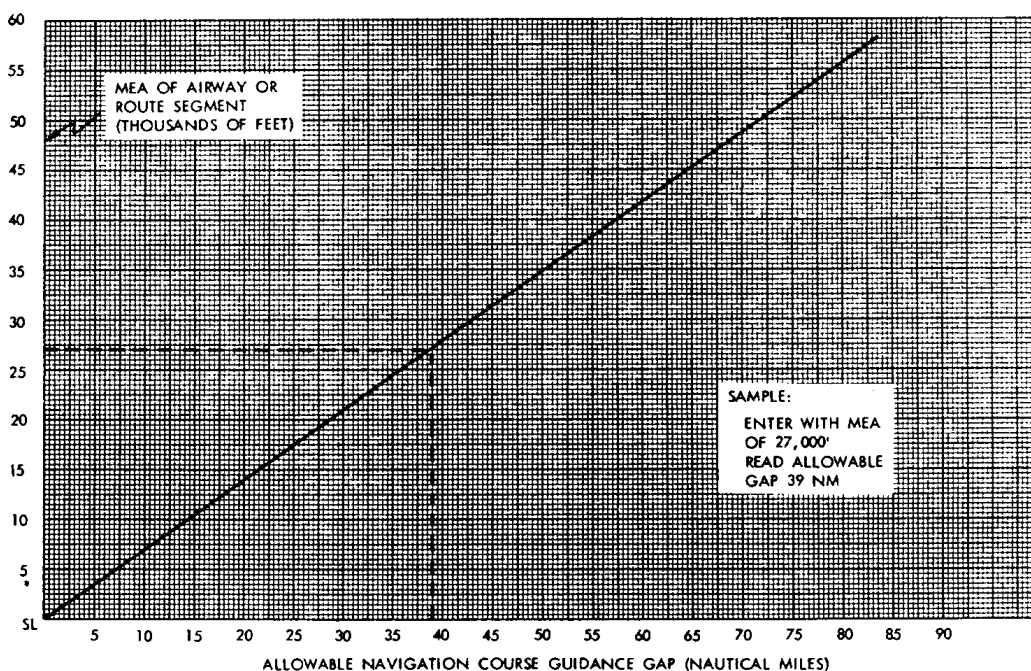

Figure 17-23. NAVIGATION COURSE GUIDANCE GAPS. Par 1740.

"steps." These steps may be established at increments of not less than 2000 feet below 18,000 feet MSL, or not less than 4000 feet at 18,000 feet MSL and above, provided that a total gap does not exist for the segment within the airspace structure. MEA steps shall be limited to one step between any two facilities to eliminate continuous or repeated changes of altitude in problem areas. MEA changes shall be identified by designated radio fixes.

d. *Gaps.* Allowable navigational gaps may be determined by reference to the graph in Figure 17-23.

Example: The problem drawn on the chart shows the method used to determine the allowable gap on a route segment with a proposed MEA of 27,000 feet. Enter the graph at the left edge with the MEA of 27,000 feet. Move to the right to the interception of the diagonal line. Move to the bottom of the graph to read the allowable gap. In the problem drawn, a 39 NM gap is allowable.

1741.-1749. RESERVED.

Section 5. Low Frequency Airways or Routes

1750. LF AIRWAYS OR ROUTES.

a. *Usage.* LF navigation facilities may be used to establish enroute airway/route segments. Then use will be limited to those instances where an operational requirement exists.

b. *Obstacle Clearance Areas.* See Figures 17-24 and 17-25.

(1) The primary obstacle clearance area boundaries of LF segments are lines drawn 4.34 NM (5 statute miles) on each side of and parallel to the segment centerline. These boundaries will be affected by obstacle clearance area factors shown in c. below.

(2) The LF secondary obstacle clearance areas extend laterally for an additional 4.34 NM on each side of the primary area. The boundaries of the secondary areas are also affected by the obstacle clearance area factors shown in c. below.

c. *Obstacle Clearance Area Factors.* See Figures 17-24 and 17-25.

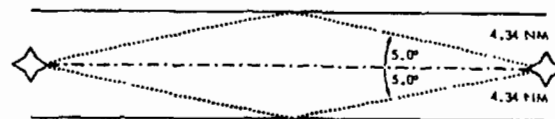

Figure 17-24 LF SEGMENT PRIMARY OBSTACLE CLEARANCE AREA Par 1750 b

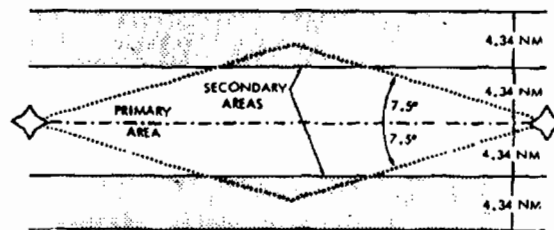

Figure 17-25. LF SEGMENT SECONDARY OBSTACLE CLEARANCE AREA Par 1750 b

(1) The primary area of LF segments is expanded in the same way as for VHF airways/routes. Lines are drawn at 5 degrees off the course centerline from each facility. These lines meet at the midpoint of the segment. Penetration of the 4.34 NM boundary occurs 49.66 (50) NM from the facility.

(2) The secondary areas are expanded in the same manner as the secondary areas for VHF airways/routes. Lines are drawn 7.5 degrees on each side of the segment centerline. These 7.5 degree lines will intersect the original 8.68 NM secondary area boundaries at 65.93 (66) NM from the facility.

d. *Obstacle Clearance.*

Policy Memo
Dec 8 2008

(1) Obstacle clearance in the primary area of LF airways or routes is the same as that required for VOR airways/routes. The areas over which the clearances apply are different, as shown in paragraph 1750.c.

(2) Secondary area obstacle clearance requirements for LF segments are based upon distance from the facility and location of the obstacle relative to the inside boundary of the secondary area.

(a) Within 25 NM of the facility the obstacle clearance is based upon a 50:1 plane drawn from the primary area boundary 500 feet above the obstacle which dictates its MOCA and extending to the edge of the secondary area. When obstacles penetrate this 50:1 plane, the MOCA for the segment will be increased above that dictated for the primary area obstacle as follows:

Distance from Primary Boundary	Add to Height of Obstacle
0 - 1 statute miles	500 feet
1 - 2 statute miles	400 feet
2 - 3 statute miles	300 feet
3 - 4 statute miles	200 feet
4 - 5 statute miles	100 feet

NOTE: See Figure 17-26 for cross section view. Also see (c) below.

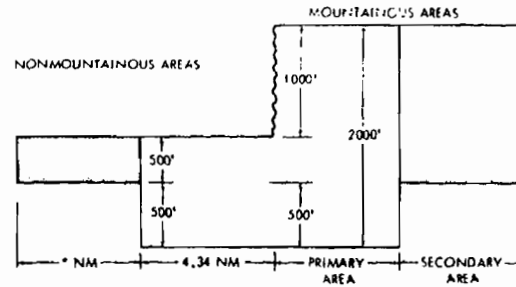

Figure 17-27 LF SEGMENT OBSTACLE CLEARANCE OVER 25 NM FROM ENROUTE FACILITY
Par 1750 d

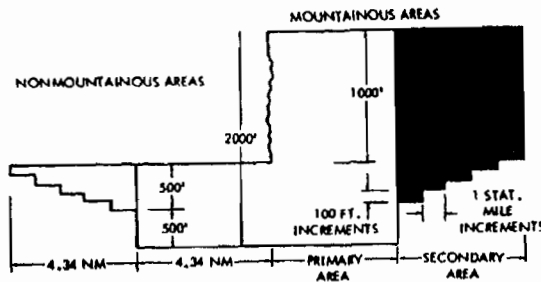

Figure 17-26 LF SEGMENT OBSTACLE CLEARANCE WITHIN 25 NM OF ENROUTE FACILITY
Par 1750 d

(b) Beyond the 25 NM distance from the facility, the secondary obstacle clearance plane is flat. This plane is drawn from the primary area boundary 500 feet above the obstacle which dictates its MOCA and extending to the edge of the secondary area. If an obstacle penetrates this surface the MOCA for the segment will be increased so as to provide 500 feet of clearance over the obstacle. See Figure 17-27. Also see (c) below.

(c) Obstacle clearance values shown in (a) and (b) above are correct for nonmountainous areas only. For areas designated as mountainous add 1000 feet.

1751.-1759. RESERVED.

Par 1750

Section 6. Minimum Divergence Angles

1760. GENERAL.

a. *Governing Facility.* The governing facility for determining the minimum divergence angle depends upon how the fix is determined.

(1) Where the fix is predicated on an off-course radial or bearing, the distance from the fix to the facility providing the off-course radial or bearing is used.

(2) Where the fix is predicated on the radials or bearings of two intersecting airways or routes, the distance between the farthest facility and the fix will be used to determine the angle.

b. *Holding.* Where holding is to be authorized at a fix, the minimum divergence angle is 45 degrees.

1761. VHF FIXES.

a. The minimum divergence angles for those fixes formed by intersecting VHF radials are determined as follows:

(1) When both radio facilities are located within 30 NM of the fix, the minimum divergence angle is 30 degrees.

(2) When the governing facility is over 30 NM from the fix, the minimum allowable angle will be increased at the rate of 1 degree per NM up to 45 NM (45 degrees).

Chap 17

(3) Beyond 45 NM, the minimum divergence angle increases at the rate of 1/2 degree per NM.

Example: Distance from fix to governing facility is 51 NM. $51 - 45 = 6$ NM. $6 \times 1/2 = 3$ additional degrees. Add to the 45 degrees required at 45 NM and get 48 degrees minimum divergence angle at 51 NM.

b. A graph (Figure 17-28) may be used to define minimum divergence angles. Using the foregoing example, enter the chart at the bottom with the facility distance (51 NM). Move up to the "VHF Fix" conversion line. Then move to the left to read the angle - 48 degrees.

1762. LF OR VHF/LF FIXES.

a. Minimum divergence angles for LF or integrated (VHF/LF) fixes are determined as follows:

(1) When the governing facility is within 30 NM of the fix, the minimum divergence angle is 45 degrees.

(2) Beyond 30 NM the minimum angle must be increased at the rate of 1 degree for each NM, except for fixes on long overwater routes where the fix will be used for reporting purposes and not for traffic separation.

Example: The distance from the governing facility is 51 NM. $51 - 30 = 21$ NM. $21 \times 1 = 21$. Add 21 to 45 degrees required at 30 NM to get the required divergence angle of 66 degrees.

b. The graph (Figure 17-28) may be used to define minimum angles for LF or VHF/LF fixes. Using the foregoing example, enter at the bottom of the chart with the 51 NM distance between facility and fix. Move up to the "LF or INTEGRATED FIX" conversion line, then left to read the required divergence angle, 66 degrees.

1763.-1799. RESERVED.

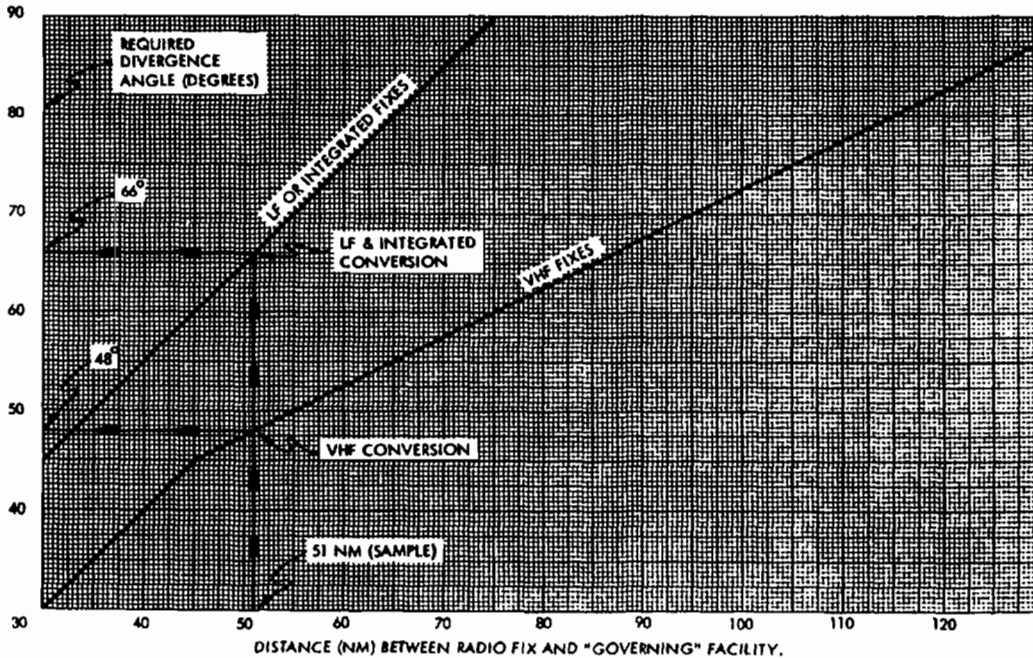

Figure 17-28 MINIMUM DIVERGENCE ANGLE FOR RADIO FIX Par 1761 b and 1762 b

THIS PAGE INTENTIONALLY LEFT BLANK

**APPENDIX 1. APPENDIX APPLICATION, GLOSSARY,
ACRONYMS, AND ABBREVIATIONS**

Policy
Memo
Dec 28
2007

1. APPENDIX APPLICATION. The material contained in these appendices supports criteria contained in several chapters of this order. Appendix material includes:

a. Appendix 1, paragraph 2. Glossary. A listing of special terms and abbreviations to explain their meaning and application to procedures and criteria.

b. Appendix 1, paragraph 3. Acronyms and Abbreviations. A listing of all acronyms and abbreviations used in this order.

c. Appendix 2. RESERVED

d. Appendix 3. References. This appendix contains a list of referenced publications.

e. Appendix 4. Table of Tangents. A complete list of tangents for angles from 0.0 to 9.0 degrees in hundredths of degrees for application in solving glide slope problems.

f. Appendix 5. Approach Lighting Systems. This appendix contains descriptions of standard approach lighting systems and lists of other systems which may be given the same visibility credit in the development of military procedures.

g. Appendix 6. Alphabetical Index.

2. GLOSSARY. Definitions shown in the glossary apply to terminal instrument procedures criteria in this order.

AL Approach and Landing (Chart).

Angle of Divergence (Minimum). The smaller of the angles formed by the intersection of two courses, radials, bearings, or combinations thereof.

ASBL Approach Surface Baseline. An imaginary horizontal line at threshold elevation.

Approving Authority. Headquarters representative of the various signatory authorities shown in the Foreword, Page iv.

BC Back Course (Localizer).

Circling Approach Area. The area in which aircraft circle to land under visual conditions after completing an instrument landing approach.

Controlling Obstacle. The highest obstacle relative to a prescribed plane within a specified area.

NOTE: In precision approach procedures where obstacles penetrate the approach surface, the controlling obstacle is the one which results in the requirement for the highest decision height (DH).

Dead Reckoning. The estimating or determining of position by advancing an earlier known position by the application of direction and speed data. For example, flight based on a heading from one VORTAC azimuth and distance fix to another is dead reckoning.

Diverse Vector. An instruction issued by a radar controller to fly a specific course, which is not a part of a predetermined radar pattern. Also referred to as a "random vector."

DH Decision Height. The height, specified in mean sea level (MSL), above the highest runway elevation in the touchdown zone at which a missed approach must be initiated if the required visual reference has not been established. This term is used only in procedures where an electronic glide slope provides the reference for descent, as in a non-instrument landing system (ILS) or precision approach radar (PAR).

DME Distance Measuring Equipment Arc. A course, indicated as a constant DME distance, around an aviation facility which provides distance information.

DME Distance. The line of sight distance (slant range) from the source of the DME signal to the receiving antenna.

FAC Final Approach Course.

FAF Final Approach Fix.

Flight Inspection. In-flight investigation and certification of certain operational performance characteristics of electronic and visual navigation

facilities by an authorized inspector in conformance with Order 8200.1, U. S. Standard Flight Inspection Manual.

Gradient. A slope expressed in feet per mile, or as a ratio of the horizontal to the vertical distance. For example, 40:1 means 40 feet horizontally to 1 foot vertically.

GPI Ground Point of Intercept. A point in the vertical plane on the runway centerline at which it is assumed that the straight line extension of the glide slope intercepts the runway approach surface baseline.

HAA Height above airport elevation.

HAT Height above touchdown zone elevation.

IAC Initial Approach Course.

IAF Initial Approach Fix.

IC Intermediate Course.

IF Intermediate Fix

JAL High Altitude Approach and Landing (Chart).

LOC Localizer. The component of an ILS which provides lateral guidance with respect to the runway centerline.

LDA Localizer type directional aid. A facility of comparable utility and accuracy to a LOC, but which is not part of a full ILS and may not be aligned with the runway.

LPV - Lateral Precision Performance with Vertical Guidance

MAP Missed Approach Point (paragraph 272).

MDA Minimum Descent Altitude (paragraph 310)

MHA Minimum Holding Altitude.

NDB (ADF) Non Directional Beacon (Airborne Automatic Direction Finder). A combined term which indicates that an NDB provides an electronic signal for use with ADF equipment.

Obstacle. An existing object, object of natural growth, or terrain at a fixed geographical location

which may be expected at a fixed location within a prescribed area, with reference to which vertical clearance is or must be provided during flight operation. For example, with reference to mobile objects, a moving vehicle 17 feet high is assumed to be on an Interstate Highway, 15 feet high on other highways, and 23 feet high on a railroad track, except where limited to certain heights controlled by use or construction. The height of a ship's mast is assumed according to the types of ships known to use an anchorage.

Obstacle Clearance. The vertical distance between the lowest authorized flight altitude and a prescribed surface within a specified area.

Obstacle Clearance Boxes 500. When used in figures which depict approach segments, these boxes indicate the obstacle clearance requirements in feet.

Operational Advantage. An improvement which benefits the users of a navigation procedure. Achievement of lower minimums or authorization for a straight-in approach with no derogation of safety is an example of an operational advantage. Many of the options in TERPS are specified for this purpose. For instance, the flexible final approach course alignment criteria may permit the ALS to be used for reduced visibility credit by selection of the proper optional course.

Optimum Most Favorable. As used in TERPS, optimum identifies the value, which should be used wherever a choice is available.

Positive Course Guidance. A continuous display of navigational data which enable a navigator to be flown along a specific course line.

Precipitous Terrain. Terrain characterized by steep or abrupt slopes.

Precision and Nonprecision. These terms are used to differentiate between navigational facilities which provide a combined azimuth and glide slope guidance to a runway (Precision) and those that do not. The term nonprecision refers to facilities without a glide slope, and does not imply an unacceptable quality of course guidance.

Primary Area. The area within a segment in which full obstacle clearance is applied.

ROC Required Obstacle Clearance.

Runway Environment. The runway threshold or approved lighting aids or other markings identifiable with the runway.

Secondary Area. The area within a segment in which R OC is reduced as distance from the prescribed course is increased.

Segment. The basic functional division of a non-instrument approach procedure. The segment is oriented with respect to the course to be flown. Specific values for determining course alignment, obstacle clearance areas, descent gradients, and obstacle clearance requirements are associated with each segment according to its functional purpose.

Service Volume. That volume of airspace surrounding a VOR, TACAN, or VORTAC facility within which a signal of usable strength exists and where that signal is not operationally limited by co-channel interference. The advertised service volume is defined as a simple cylinder of airspace for ease in planning areas of operation.

TCH Threshold Crossing Height. The height of the straight line extension of the glide slope above the runway at the threshold.

TDZ Touchdown Zone. The first 3,000 feet of runway beginning at the threshold.

TDZE Touchdown Zone Elevation. The highest runway centerline elevation in the touchdown zone.

Transition Level. The flight level below which heights are expressed in feet MSL and are based on an approved station altimeter setting.

VDP Visual Descent Point. The VDP is a defined point on the final approach course of a nonprecision straight-in approach procedure from which normal descent from the MDA to the runway touchdown point may be commenced, provided visual reference is established.

3. ACRONYMS AND ABBREVIATIONS. Many acronyms and abbreviations for old and new aviation terms are used throughout this order. Users of this order can refer to the following alphabetical listing of frequently used acronyms and abbreviations:

AAF	Airway Facilities Service
ABM	abeam
AC	Advisory Circular
ADF	automatic direction finder
AFM	Airplane Flight Manual

AFS	Flight Standards Service
AFSS	Automated Flight Service Station
AGL	above ground level
AIM	Aeronautical Information Manual
ALPA	Air Line Pilots Association
ALSF-1	approach lighting system with sequenced flashing lights (CAT I Configuration)
ALSF-2	approach lighting system with sequenced flashing lights (CAT II Configuration)
AOPA	Aircraft Owners and Pilots Association
APV	approach with vertical guidance (ICAO)
ARA	airborne radar approach
ARC	Airport Reference Code
ARDH	achieved reference datum height
ARINC	Aeronautical Radio, Inc.
ARP	airport reference point
ARSR	air route surveillance radar
ARTCC	Air Route Traffic Control Center
ASBL	approach surface baseline
ASOS	automated surface observing system
ASR	airport surveillance radar
AT	Air Traffic
ATA	Air Transport Association
ATC	Air Traffic Control
ATD	along track distance
ATRK	along track
ATS	Air Traffic Service
AVN	Aviation System Standards
AWO	all weather operations
AWOP	All Weather Operations Panel
AWO/PM	All Weather Operations/Program Manager
AWOS	automated weather observation system
AWS	Aviation Weather System
Baro VNAV	Barometric vertical navigation
BC	back course
CAT	Category
CF	course to fix
CFIT	controlled flight into terrain
CFR	Code of Federal Regulations
CG	climb gradient
CGL	circling guidance light
CHDO	Certificate Holding District Office
CIH	climb-in-hold
CMO	Certificate Management Office
CMT	Certificate Management Team
CONUS	Continental United States
COP	changeover point
CRM	collision risk model
CW	course width
CWSU	Center Weather Service Unit
CY	Calendar Year
DA	decision altitude
dB	decibel
DCG	desired climb gradient
DER	departure end of runway
DF	direct to fix

DF	direction finder	HAI	Helicopter Association International
DG	descent gradient	HAL	height above landing area elevation
DH	decision height	HAS	height above surface
DME	distance measuring equipment	HAT	height above touchdown
DOD	Department of Defense	HATh	height above threshold
DOT	Department of Transportation	HCH	heliport crossing height
DP	departure procedure	HF	high frequency
DR	dead reckoning	HIRL	high intensity runway lights
DRL	departure reference line	HRP	heliport reference point
DRP	departure reference point	HUD	heads-up display
DTA	distance turn anticipation	IAC	initial approach course
DVA	diverse vector area	IAF	initial approach fix
EARTS	en route automated radar tracking system	IAP	instrument approach procedure
EDA	elevation differential area	IAPA	instrument approach procedure automation
ESA	emergency safe altitudes	IC	intermediate course
ESV	expanded service volume	ICA	initial climb area
FAA	Federal Aviation Administration	ICAB	ICA baseline
FAATC	FAA Technical Center	ICAE	ICA end-line
FAC	final approach course	ICAO	International Civil Aviation Organization
FAF	final approach fix	ICWP	initial course waypoint
FAP	final approach point	IDF	initial departure fix
FAR	Federal Aviation Regulations	IF	intermediate fix
FAS	final approach segment	IF	initial fix
FATO	final approach and takeoff area	IF/IAF	intermediate/initial approach fix
FAWP	final approach waypoint	IFR	instrument flight rules
FDC	Flight Data Control	ILS	instrument landing system
FDR	Flight Data Record	IMC	instrument meteorological conditions
FDT	fix displacement tolerance	INS	inertial navigation system
FEP	final end point	IPV	instrument procedure with vertical guidance
FIFO	Flight Inspection Field Office	IRU	inertial reference unit
FMS	flight management system	ISA	International Standard Atmosphere
FPAP	flight path alignment point	kHz	kilohertz
FPCP	flight path control point	KIAS	knots indicated airspeed
FPO	Flight Procedures Office	LAAS	Local Area Augmentation System
FR	Federal Register	LAB	landing area boundary
FSDO	Flight Standards District Office	LAHSO	land and hold short operations
FSS	Flight Service Station	LDA	localizer type directional aid
FTE	flight technical error	LDIN	lead-in lighting system
FTIP	Foreign terminal instrument procedure	LF	low frequency
FTP	fictitious threshold point	LIRL	low intensity runway lights
GA	general Aviation	LNAV	lateral navigation
GCA	ground controlled approach	LPV	Lateral Precision Performance with Vertical Guidance
GH	Geoid Height	LOA	Letter of Agreement
GLONASS	Global Orbiting Navigation Satellite System	LOB	lines of business
GLS	GNSS Landing System	LOC	localizer
GNSS	Global Navigation Satellite System	LOM	locator outer marker
GP	glidepath	LORAN	long range navigation system
GPA	glidepath angle	LTP	landing threshold point
GPI	ground point of intercept	MALS	minimum intensity approach lighting system
GPS	Global Positioning System	MALSF	minimum intensity approach lighting system with sequenced flashing
GRI	group repetition interval		
GS	glide slope		
HAA	height above airport		
HAE	height above ellipsoid		
HAH	height above heliport		

MALSR	minimum intensity approach lighting system with runway alignment indicator lights	PAPI	precision approach path indicator
MAP	missed approach point	PAR	precision approach radar
MCA	minimum crossing altitude	PCG	positive course guidance
MDA	minimum descent altitude	PDA	preliminary decision altitude
MEA	minimum en route altitude	PFAF	precision final approach fix
MHA	minimum holding altitude	PGPI	pseudo ground point of intercept
MHz	megahertz	PinS	point-in-space
MIA	minimum IFR altitudes	PLS	precision landing system
MIRL	medium intensity runway lights	POC	point of contact
MLS	Microwave Landing System	PRM	precision runway monitor
MM	middle marker	PT	procedure turn
MOA	Memorandum of Agreement	PVG	positive vertical guidance
MOA	military operations area	PVGSI	pseudo visual glide slope indicator
MOC	minimum obstacle clearance	RA	radio altimeter
MOCA	minimum obstruction clearance altitude	RAA	Regional Airline Association
MOU	Memorandum of Understanding	RAIL	runway alignment indicator lights
MRA	minimum reception altitude	RAPCON	radar approach control
MSA	minimum safe/sector altitude	RASS	remote altimeter setting source
MSL	mean sea level	RCL	runway centerline
MTA	minimum turn altitude	RDP	reference datum point
MVAC	minimum vectoring altitude chart	REIL	runway end identifier lights
NAD	North American Datum	RF	radio frequency
NAS	National Airspace System	RF	radius to fix
NAVAID	navigational aid	RNAV	area navigation
NAWAU	National Aviation Weather Advisory Unit	RNP	required navigation performance
NBAA	National Business Aviation Association	ROC	required obstacle clearance
NDB	nondirectional radio beacon	RPI	runway point of intercept
NFDC	National Flight Data Center	RRP	runway reference point
NFDD	National Flight Data Digest	RTCA	Radio Technical Commission for Aeronautics
NFPO	National Flight Procedures Office	RVR	runway visual range
NM	nautical mile	RWP	runway threshold waypoint
NOAA	National Oceanic and Atmospheric Administration	RWT	runway threshold
NOS	National Ocean Service	RWTE	runway threshold evaluation
NOTAM	Notice to Airmen	RWY	runway
NOZ	normal operating zone	SALS	short approach lighting system
NPA	nonprecision approach	SATNAV	satellite navigation
NTSB	National Transportation Safety Board	SCG	standard climb gradient
NTZ	no transgression zone	SDF	simplified directional facility
NWS	National Weather Service	SDF	step-down fix
OC	obstruction chart	SER	start end of runway
OCA	obstacle clearance altitude	SIAP	standard instrument approach procedure
OCH	obstacle clearance height	SID	standard instrument departure
OCS	obstacle clearance surface	SM	statute mile
ODALS	omnidirectional approach lighting system	SSALF	short simplified approach lighting system with sequenced flashers
OEA	obstruction evaluation area	SSALR	short simplified approach lighting system with runway alignment indicator lights
OE/AAA	Obstruction Evaluation/Airport Airspace Analysis	STAR	standard terminal arrival route
OFA	object free area	STOL	short takeoff and landing
OIS	obstacle identification surface	TAA	terminal arrival area
OM	outer marker	TACAN	tactical air navigational aid
ORE	obstacle rich environment	TCH	threshold crossing height
OSAP	off-shore approach procedure	TD	time difference
PA	precision approach	TDP	touchdown point
		TDZ	touchdown zone

TDZE	touchdown zone elevation	VDA	vertical descent area
TDZL	touchdown zone lights (system)	VDP	visual descent point
TERPS	terminal instrument procedures	VFR	visual flight rules
TF	track to fix	VGA	vertically guided approach
TL	Transmittal Letter	VGSI	visual glide slope indicator
TLOF	touchdown and life-off area	VHF	very high frequency
TLS	transponder landing system	VLF	very low frequency
TORA	takeoff runway available	VMC	visual meteorological conditions
TP	tangent point	VNAV	vertical navigation
TPD	tangent point distance	VOR	very high frequency omnidirectional radio range
TRACON	terminal radar approach control facility	VOR/DME	very high frequency omnidirectional radio range collocated with distance measuring equipment
TSO	technical standard order	VORTAC	very high frequency omnidirectional radio range collocated with tactical air navigation
TWP	turn waypoint	VPA	vertical path angle
UHF	ultra high frequency	VSDA	visual segment descent angle
USA	U.S. Army	VTOL	vertical take-off and landing
USAF	U.S. Air Force	WAAS	Wide Area Augmentation System
USCG	U.S. Coast Guard	WCH	wheel crossing height
USMC	U.S. Marine Corps	XTRK	crosstrack
USN	U.S. Navy		
VA	heading to altitude		
VASI	visual approach slope indicator		
VCA	visual climb area		
VCOA	visual climb over airport		

1. REFERENCES

c. FAA Directives.

<i>a. Federal Aviation Regulations.</i>			
FAR 77	Objects Affecting Navigable Airspace.	1010.3A	Selection Order; Runway CL & TDZ Lighting.
FAR 97	Standard Instrument Approach Procedures.	1010.11	Selection Order; Separation of Parallel Runways for Simultane- ous ILS Approaches.
FAR 121	Certification & Operations: Air Carriers and Commercial Opera- tors of Large Aircraft.	1010.39A	Selection Order; Category II ALS.
FAR 171	Non-Federal Navigation Facilities.	1010.43	Selection Order; MALS.
		1010.52	Selection Order; Lead-In Light- ing System.
		1010.55	Selection Order; US National Aviation System for the VOR- TAC System.
<i>b. FAA Advisory Circulars.</i>			
AC 70/7460-1D	Obstruction Marking and Lighting.	6700.1	Non-Federal Navigational Facilities.
AC 90-45A	Approval of Area Navigation Systems for Use in the U.S. Na- tional Airspace System.	6700.10B	Non-Federal Navigational Facilities.
AC 90-70	Straight-in nonprecision instru- ment approach procedures vi- sual descent point (VDP).	6700.12B	Criteria for FAA Assumption of Non-federal Navigational and Air Traffic Control Facilities.
AC 91-14B	Altimeter Setting Sources	6850.2	Visual Guidance Lighting System.
AC 91-16	Category II Operations - Gen- eral Aviation Airplanes.	6990.3	Implementation of Standard FAA STD-008 "Siting and In- stallation Standards for RVR Equipment for Category I & II Operations."
AC 95-1	Airway and Route Obstruction Clearances.		Holding Pattern Criteria.
AC 120-28A	Criteria for Approval of Cate- gory IIIa Landing Weather Minima.	7130.3	U.S. Air Force Special Training Instrument Approach Procedures.
AC 120-29	Criteria for Approving Category I and Category II Landing Min- ima for FAR 121 Operators.	7230.13	Reduced Hours of Operation for Airport Traffic Control Towers.
AC 150/5300-2C	Airport Design Standards - Site Requirements for Terminal Nav- igational Facilities.	7232.5D	Procedures for Handling Air- space Cases.
AC 150/5340-1D	Marking of Paved Areas on Airports.	7400.2B	U.S. Standard Flight Inspection Manual.
AC 150/5340-4B	Installation Details for Runway Centerline and TDZ Lighting Systems.	OA P 8200.1	Simplified Directional Facilities. Designated RVR Runway.
AC 150/5340-13B	High Intensity Lighting Systems.	8200.28A	U.S. Army Terminal Instrument Procedures Service.
AC 150/5340-14B	Economy Approach Lighting Aids.	8260.1	Establishing Requirements for Visual Approach Aids.
AC 150/5340-16B	MIRL System and Visual Ap- proach Slope Indicators for Util- ity Airports.	8260.15A	Flight Procedures and Airspace. Category I ILS Threshold Cross- ing Height.
		8260.18A	
		8260.19	
		8260.24B	

8260.26	Establishing and Scheduling Instrument Approach Procedure Effective Dates	8430.6A	Air Carrier Operations Inspector's Manual.
8260.27	Effect of Runway Markings on SIAP Visibility Minimums.	8430.10B	IFR Approval of Private-Use Microwave Landing Systems.
8260.28	IFR Approval of the Interim Standard Microwave Landing System (ISMLS).	<i>d. Other</i>	
8430.1A	Operations Inspection & Surveillance Procedures – Air Taxi Operators & Commercial Operators of Small Aircraft.	IACC No. 4	U.S. Government Specifications for Flight Information Publications – Low Altitude Instrument Approach Procedure.

1. TABLE OF TANGENTS

Degrees	Tangent	Degrees	Tangent	Degrees	Tangent	Degrees	Tangent
0.0 =	.00000	1.36=	.02374	1.82=	.03178	2.28=	.03981
0.1 =	.00175	1.37=	.02392	1.83=	.03195	2.29=	.03999
0.2 =	.00349	1.38=	.02409	1.84=	.03213	2.3 =	.04016
0.3 =	.00524	1.39=	.02426	1.85=	.03230	2.31=	.04034
0.4 =	.00698	1.4 =	.02444	1.86=	.03247	2.32=	.04051
0.5 =	.00873	1.41=	.02461	1.87=	.03265	2.33=	.04069
0.6 =	.01047	1.42=	.02479	1.88=	.03282	2.34=	.04086
0.7 =	.01222	1.43=	.02496	1.89=	.03300	2.35=	.04104
0.8 =	.01396	1.44=	.02514	1.9 =	.03317	2.36=	.04121
0.9 =	.01571	1.45=	.02531	1.91=	.03335	2.37=	.04139
1.0 =	.01746	1.46=	.02549	1.92=	.03352	2.38=	.04156
1.01=	.01763	1.47=	.02566	1.93=	.03370	2.39=	.04174
1.02=	.01780	1.48=	.02584	1.94=	.03387	2.4 =	.04191
1.03=	.01798	1.49=	.02601	1.95=	.03405	2.41=	.04209
1.04=	.01815	1.5 =	.02619	1.96=	.03422	2.42=	.04226
1.05=	.01833	1.51=	.02636	1.97=	.03440	2.43=	.04244
1.06=	.01850	1.52=	.02654	1.98=	.03457	2.44=	.04261
1.07=	.01868	1.53=	.02671	1.99=	.03475	2.45=	.04279
1.08=	.01885	1.54=	.02688	2.0 =	.03492	2.46=	.04296
1.09=	.01903	1.55=	.02706	2.01=	.03510	2.47=	.04314
1.1 =	.01920	1.56=	.02723	2.02=	.03527	2.48=	.04331
1.11=	.01938	1.57=	.02741	2.03=	.03545	2.49=	.04349
1.12=	.01955	1.58=	.02758	2.04=	.03562	2.5 =	.04366
1.13=	.01972	1.59=	.02776	2.05=	.03579	2.51=	.04384
1.14=	.01990	1.6 =	.02793	2.06=	.03597	2.52=	.04401
1.15=	.02007	1.61=	.02811	2.07=	.03614	2.53=	.04419
1.16=	.02025	1.62=	.02828	2.08=	.03632	2.54=	.04436
1.17=	.02042	1.63=	.02846	2.09=	.03649	2.55=	.04454
1.18=	.02060	1.64=	.02863	2.1 =	.03667	2.56=	.04471
1.19=	.02077	1.65=	.02881	2.11=	.03684	2.57=	.04489
1.2 =	.02095	1.66=	.02898	2.12=	.03702	2.58=	.04506
1.21=	.02112	1.67=	.02916	2.13=	.03719	2.59=	.04523
1.22=	.02130	1.68=	.02933	2.14=	.03737	2.6 =	.04541
1.23=	.02147	1.69=	.02950	2.15=	.03754	2.61=	.04558
1.24=	.02165	1.7 =	.02968	2.16=	.03772	2.62=	.04576
1.25=	.02182	1.71=	.02985	2.17=	.03789	2.63=	.04593
1.26=	.02199	1.72=	.03003	2.18=	.03807	2.64=	.04611
1.27=	.02217	1.73=	.03020	2.19=	.03824	2.65=	.04628
1.28=	.02234	1.74=	.03038	2.2 =	.03842	2.66=	.04646
1.29=	.02252	1.75=	.03055	2.21=	.03859	2.67=	.04663
1.30=	.02269	1.76=	.03073	2.22=	.03877	2.68=	.04681
1.31=	.02287	1.77=	.03090	2.23=	.03894	2.69=	.04698
1.32=	.02304	1.78=	.03108	2.24=	.03912	2.7 =	.04716
1.33=	.02322	1.79=	.03125	2.25=	.03929	2.71=	.04733
1.34=	.02339	1.8 =	.03143	2.26=	.03946	2.72=	.04751
1.35=	.02357	1.81=	.03160	2.27=	.03964	2.73=	.04768

Degrees	Tangent	Degrees	Tangent	Degrees	Tangent	Degrees	Tangent
2.74=	.04786	3.22=	.05626	3.7 =	.06467	4.18=	.07308
2.75=	.04803	3.23=	.05643	3.71=	.06484	4.19=	.07326
2.76=	.04821	3.24=	.05661	3.72=	.06502	4.2 =	.07344
2.77=	.04838	3.25=	.05678	3.73=	.06519	4.21=	.07361
2.78=	.04856	3.26=	.05696	3.74=	.06537	4.22=	.07379
2.79=	.04873	3.27=	.05713	3.75=	.06554	4.23=	.07396
2.8 =	.04891	3.28=	.05731	3.76=	.06572	4.24=	.07414
2.81=	.04908	3.29=	.05748	3.77=	.06589	4.25=	.07431
2.82=	.04926	3.3 =	.05766	3.78=	.06607	4.26=	.07449
2.83=	.04943	3.31=	.05783	3.79=	.06624	4.27=	.07466
2.84=	.04961	3.32=	.05801	3.8 =	.06642	4.28=	.07484
2.85=	.04978	3.33=	.05818	3.81=	.06660	4.29=	.07501
2.86=	.04996	3.34=	.05836	3.82=	.06677	4.3 =	.07519
2.87=	.05013	3.35=	.05854	3.83=	.06695	4.31=	.07537
2.88=	.05031	3.36=	.05871	3.84=	.06712	4.32=	.07554
2.89=	.05048	3.37=	.05889	3.85=	.06730	4.33=	.07572
2.9 =	.05066	3.38=	.05906	3.86=	.06747	4.34=	.07589
2.91=	.05083	3.39=	.05924	3.87=	.06765	4.35=	.07607
2.92=	.05101	3.4 =	.05941	3.88=	.06782	4.36=	.07624
2.93=	.05118	3.41=	.05959	3.89=	.06800	4.37=	.07642
2.94=	.05136	3.42=	.05976	3.9 =	.06817	4.38=	.07659
2.95=	.05153	3.43=	.05994	3.91=	.06835	4.39=	.07677
2.96=	.05171	3.44=	.06011	3.92=	.06852	4.4 =	.07695
2.97=	.05188	3.45=	.06029	3.93=	.06870	4.41=	.07712
2.98=	.05206	3.46=	.06046	3.94=	.06887	4.42=	.07730
2.99=	.05223	3.47=	.06064	3.95=	.06905	4.43=	.07747
3.0 =	.05241	3.48=	.06081	3.96=	.06923	4.44=	.07765
3.01=	.05258	3.49=	.06099	3.97=	.06940	4.45=	.07782
3.02=	.05276	3.5 =	.06116	3.98=	.06958	4.46=	.07800
3.03=	.05293	3.51=	.06134	3.99=	.06975	4.47=	.07817
3.04=	.05311	3.52=	.06151	4.0 =	.06993	4.48=	.07835
3.05=	.05328	3.53=	.06169	4.01=	.07010	4.49=	.07853
3.06=	.05346	3.54=	.06186	4.02=	.07028	4.5 =	.07870
3.07=	.05363	3.55=	.06204	4.03=	.07045	4.51=	.07888
3.08=	.05381	3.56=	.06221	4.04=	.07063	4.52=	.07905
3.09=	.05398	3.57=	.06239	4.05=	.07080	4.53=	.07923
3.1 =	.05416	3.58=	.06256	4.06=	.07098	4.54=	.07940
3.11=	.05433	3.59=	.06274	4.07=	.07115	4.55=	.07958
3.12=	.05451	3.6 =	.06291	4.08=	.07133	4.56=	.07976
3.13=	.05468	3.61=	.06309	4.09=	.07151	4.57=	.07993
3.14=	.05486	3.62=	.06327	4.1 =	.07168	4.58=	.08011
3.15=	.05503	3.63=	.06344	4.11=	.07186	4.59=	.08028
3.16=	.05521	3.64=	.06362	4.12=	.07203	4.6 =	.08046
3.17=	.05538	3.65=	.06379	4.13=	.07221	4.61=	.08063
3.18=	.05556	3.66=	.06397	4.14=	.07238	4.62=	.08081
3.19=	.05573	3.67=	.06414	4.15=	.07256	4.63=	.08099
3.2 =	.05591	3.68=	.06432	4.16=	.07273	4.64=	.08116
3.21=	.05608	3.69=	.06449	4.17=	.07291	4.65=	.08134

Degrees	Tangent	Degrees	Tangent	Degrees	Tangent	Degrees	Tangent
4.66=	.08151	5.14=	.08995	5.62=	.09840	6.1 =	.10687
4.67=	.08169	5.15=	.09013	5.63=	.09858	6.11=	.10705
4.68=	.08186	5.16=	.09030	5.64=	.09876	6.12=	.10722
4.69=	.08204	5.17=	.09048	5.65=	.09893	6.13=	.10740
4.7 =	.08221	5.18=	.09066	5.66=	.09911	6.14=	.10758
4.71=	.08239	5.19=	.09083	5.67=	.09928	6.15=	.10775
4.72=	.08257	5.2 =	.09101	5.68=	.09946	6.16=	.10793
4.73=	.08274	5.21=	.09118	5.69=	.09964	6.17=	.10811
4.74=	.08292	5.22=	.09136	5.7 =	.09981	6.18=	.10828
4.75=	.08309	5.23=	.09154	5.71=	.09999	6.19=	.10846
4.76=	.08327	5.24=	.09171	5.72=	.10017	6.2 =	.10863
4.77=	.08345	5.25=	.09189	5.73=	.10034	6.21=	.10881
4.78=	.08362	5.26=	.09206	5.74=	.10052	6.22=	.10899
4.79=	.08380	5.27=	.09224	5.75=	.10069	6.23=	.10916
4.8 =	.08397	5.28=	.09242	5.76=	.10087	6.24=	.10934
4.81=	.08415	5.29=	.09259	5.77=	.10105	6.25=	.10952
4.82=	.08432	5.3 =	.09277	5.78=	.10122	6.26=	.10969
4.83=	.08450	5.31=	.09294	5.79=	.10140	6.27=	.10987
4.84=	.08468	5.32=	.09312	5.8 =	.10158	6.28=	.11005
4.85=	.08485	5.33=	.09330	5.81=	.10175	6.29=	.11022
4.86=	.08503	5.34=	.09347	5.82=	.10193	6.3 =	.11040
4.87=	.08520	5.35=	.09365	5.83=	.10211	6.31=	.11058
4.88=	.08538	5.36=	.09382	5.84=	.10228	6.32=	.11075
4.89=	.08555	5.37=	.09400	5.85=	.10246	6.33=	.11093
4.9 =	.08573	5.38=	.09418	5.86=	.10263	6.34=	.11111
4.91=	.08591	5.39=	.09435	5.87=	.10281	6.35=	.11128
4.92=	.08608	5.4 =	.09453	5.88=	.10299	6.36=	.11146
4.93=	.08626	5.41=	.09470	5.89=	.10316	6.37=	.11164
4.94=	.08643	5.42=	.09488	5.9 =	.10334	6.38=	.11181
4.95=	.08661	5.43=	.09506	5.91=	.10352	6.39=	.11199
4.96=	.08679	5.44=	.09523	5.92=	.10369	6.4 =	.11217
4.97=	.08696	5.45=	.09541	5.93=	.10387	6.41=	.11234
4.98=	.08714	5.46=	.09558	5.94=	.10405	6.42=	.11252
4.99=	.08731	5.47=	.09576	5.95=	.10422	6.43=	.11270
5.0 =	.08749	5.48=	.09594	5.96=	.10440	6.44=	.11287
5.01=	.08766	5.49=	.09611	5.97=	.10457	6.45=	.11305
5.02=	.08784	5.5 =	.09629	5.98=	.10475	6.46=	.11323
5.03=	.08802	5.51=	.09647	5.99=	.10493	6.47=	.11341
5.04=	.08819	5.52=	.09664	6.0 =	.10510	6.48=	.11358
5.05=	.08837	5.53=	.09682	6.01=	.10528	6.49=	.11376
5.06=	.08854	5.54=	.09699	6.02=	.10546	6.5 =	.11394
5.07=	.08872	5.55=	.09717	6.03=	.10563	6.51=	.11411
5.08=	.08890	5.56=	.09735	6.04=	.10581	6.52=	.11429
5.09=	.08907	5.57=	.09752	6.05=	.10599	6.53=	.11447
5.1 =	.08925	5.58=	.09770	6.06=	.10616	6.54=	.11464
5.11=	.08942	5.59=	.09787	6.07=	.10634	6.55=	.11482
5.12=	.08960	5.6 =	.09805	6.08=	.10652	6.56=	.11500
5.13=	.08978	5.61=	.09823	6.09=	.10669	6.57=	.11517

Degrees	Tangent	Degrees	Tangent	Degrees	Tangent	Degrees	Tangent
6.58=	.11535	7.06=	.12385	7.54=	.13236	8.02=	.14090
6.59=	.11553	7.07=	.12402	7.55=	.13254	8.03=	.14107
6.6 =	.11570	7.08=	.12420	7.56=	.13272	8.04=	.14125
6.61=	.11588	7.09=	.12438	7.57=	.13290	8.05=	.14143
6.62=	.11606	7.1 =	.12456	7.58=	.13307	8.06=	.14161
6.63=	.11623	7.11=	.12473	7.59=	.13325	8.07=	.14179
6.64=	.11641	7.12=	.12491	7.6 =	.13343	8.08=	.14196
6.65=	.11659	7.13=	.12509	7.61=	.13361	8.09=	.14214
6.66=	.11677	7.14=	.12527	7.62=	.13378	8.1 =	.14232
6.67=	.11694	7.15=	.12544	7.63=	.13396	8.11=	.14250
6.68=	.11712	7.16=	.12562	7.64=	.13414	8.12=	.14268
6.69=	.11730	7.17=	.12580	7.65=	.13432	8.13=	.14286
6.7 =	.11747	7.18=	.12597	7.66=	.13449	8.14=	.14303
6.71=	.11765	7.19=	.12615	7.67=	.13467	8.15=	.14321
6.72=	.11783	7.2 =	.12633	7.68=	.13485	8.16=	.14339
6.73=	.11800	7.21=	.12651	7.69=	.13503	8.17=	.14357
6.74=	.11818	7.22=	.12668	7.7 =	.13521	8.18=	.14375
6.75=	.11836	7.23=	.12686	7.71=	.13538	8.19=	.14392
6.76=	.11853	7.24=	.12704	7.72=	.13556	8.2 =	.14410
6.77=	.11871	7.25=	.12722	7.73=	.13574	8.21=	.14428
6.78=	.11889	7.26=	.12739	7.74=	.13592	8.22=	.14446
6.79=	.11907	7.27=	.12757	7.75=	.13609	8.23=	.14464
6.8 =	.11924	7.28=	.12775	7.76=	.13627	8.24=	.14481
6.81=	.11942	7.29=	.12793	7.77=	.13645	8.25=	.14499
6.82=	.11960	7.3 =	.12810	7.78=	.13663	8.26=	.14517
6.83=	.11977	7.31=	.12828	7.79=	.13681	8.27=	.14535
6.84=	.11995	7.32=	.12846	7.8 =	.13698	8.28=	.14553
6.85=	.12013	7.33=	.12864	7.81=	.13716	8.29=	.14571
6.86=	.12031	7.34=	.12881	7.82=	.13734	8.3 =	.14588
6.87=	.12048	7.35=	.12899	7.83=	.13752	8.31=	.14606
6.88=	.12066	7.36=	.12917	7.84=	.13769	8.32=	.14624
6.89=	.12084	7.37=	.12934	7.85=	.13787	8.33=	.14642
6.9 =	.12101	7.38=	.12952	7.86=	.13805	8.34=	.14660
6.91=	.12119	7.39=	.12970	7.87=	.13823	8.35=	.14678
6.92=	.12137	7.4 =	.12988	7.88=	.13841	8.36=	.14695
6.93=	.12154	7.41=	.13005	7.89=	.13858	8.37=	.14713
6.94=	.12172	7.42=	.13023	7.9 =	.13876	8.38=	.14731
6.95=	.12190	7.43=	.13041	7.91=	.13894	8.39=	.14749
6.96=	.12208	7.44=	.13059	7.92=	.13912	8.4 =	.14767
6.97=	.12225	7.45=	.13076	7.93=	.13930	8.41=	.14785
6.98=	.12243	7.46=	.13094	7.94=	.13947	8.42=	.14802
6.99=	.12261	7.47=	.13112	7.95=	.13965	8.43=	.14820
7.0 =	.12278	7.48=	.13130	7.96=	.13983	8.44=	.14838
7.01=	.12296	7.49=	.13147	7.97=	.14001	8.45=	.14856
7.02=	.12314	7.5 =	.13165	7.98=	.14018	8.46=	.14874
7.03=	.12332	7.51=	.13183	7.99=	.14036	8.47=	.14892
7.04=	.12349	7.52=	.13201	8.0 =	.14054	8.48=	.14909
7.05=	.12367	7.53=	.13219	8.01=	.14072	8.49=	.14927

Degrees	Tangent	Degrees	Tangent	Degrees	Tangent	Degrees	Tangent
8.5 =	.14945	8.63 =	.15177	8.76 =	.15409	8.89 =	.15642
8.51 =	.14963	8.64 =	.15195	8.77 =	.15427	8.9 =	.15660
8.52 =	.14981	8.65 =	.15213	8.78 =	.15445	8.91 =	.15677
8.53 =	.14999	8.66 =	.15231	8.79 =	.15463	8.92 =	.15695
8.54 =	.15016	8.67 =	.15249	8.8 =	.15481	8.93 =	.15713
8.55 =	.15034	8.68 =	.15266	8.81 =	.15499	8.94 =	.15731
8.56 =	.15052	8.69 =	.15284	8.82 =	.15517	8.95 =	.15749
8.57 =	.15070	8.7 =	.15302	8.83 =	.15534	8.96 =	.15767
8.58 =	.15088	8.71 =	.15320	8.84 =	.15552	8.97 =	.15785
8.59 =	.15106	8.72 =	.15338	8.85 =	.15570	8.98 =	.15803
8.6 =	.15124	8.73 =	.15356	8.86 =	.15588	8.99 =	.15821
8.61 =	.15141	8.74 =	.15374	8.87 =	.15606	9.0 =	.15838
8.62 =	.15159	8.75 =	.15392	8.88 =	.15624		

THIS PAGE INTENTIONALLY LEFT BLANK

1. APPROACH LIGHTING SYSTEMS. An approach lighting system is a configuration of signal lights disposed symmetrically about the extended runway centerline starting at the landing threshold and extending outward into the approach zone. Several systems are designed with rows of lightbars, wing lightbars, and distinguishable crossbars to provide visual cues for runway alignment, height perception, roll guidance, and horizon references. Some systems are augmented with a single row of flashing lights aligned on the extended runway centerline. When a single row of flashing lights is employed as an independent system, only the runway alignment cue is provided. At civil airports, systems used in conjunction with precision approaches (such as an ILS) shall be a minimum length of 2,400 feet at locations which have a glide slope of 2.75° or higher. Locations which have a glide slope less than 2.75° require a 3,000 foot system. For nonprecision approaches, the systems are 1,400 feet. Detailed configurational layouts and specifications are depicted in FAA Handbooks 6850.2 and 6850.5 for U.S. standard installations. For military airports, see applicable service directives.

a. Sequenced Flashers. Those approach lighting systems designated with flashing lights are augmented with a system of sequenced flashing lights. Such lights are installed at each centerline bar normally starting 1,000 feet from the threshold out to the end of the system. These lights emit a bluish-white light and flash in sequence toward the threshold at a rate of twice per second.

b. RAIL. Runway Alignment Indicator Lights. RAIL consists of sequenced flashing lights installed on the extended runway centerline beyond the associated approach lighting system. The first light is located 200 feet from the lightbar farthest from the runway threshold. Successive units are spaced 200 feet apart outward into the approach zone for a specified distance.

2. NONSTANDARD SYSTEMS. Approach lighting systems other than the U.S. standard installations may be considered equivalent to the

standard systems for the purpose of formulating minimums authorized for military procedures, provided requirements of paragraph 344 are met. This appendix illustrates several non-U.S. standard systems and is offered as a guide to the determination of equivalency.

3. ALSF-1 (Type A₁)*. Approach Lighting System with Sequenced Flashing Lights, Category I Configuration.

a. System Description. The category I ALSF (ALSF-1) consists of a centerline lightbar approximately 13 1/2 feet long with five equally spaced lights at each 100-foot interval, starting 300 feet from the runway threshold and continuing out to 2,400 or 3,000 feet from the threshold. The centerline lightbar at 1,000 feet from the threshold is 100 feet long and contains 21 lights. All of the aforementioned lights are white. The lightbar 200 feet from the threshold is 50 feet long, contains 11 red lights, and is called the terminating bar. Two lightbars, each containing five red lights, are located 100 feet from the threshold, one on either side of the centerline, and are called wingbars. A row of green lights on 5-foot centers is located near the threshold and extends across the runway threshold and outwards a distance of approximately 45 feet from the runway edge on either side of the runway. See Figure 134.

b. Equivalent Systems. When the characteristics described in paragraph 3a exist in the following systems, the appropriate visibility reductions may be applied to MILITARY instrument approach procedures and FAR 121 operations at foreign airports.

Type* Description

- B U. S. Configuration B
- BN Former NATO Standard C *
- BP NATO Standard *
- J Calvert (United Kingdom)
- O Centerline High Intensity (Europe)
- T Centre Row DOT Standard High Intensity (Canada)

Policy
Memo
Dec 28
2007

Appendix 5

*NOTE: "Type" refers to the system identification letters assigned to approach lighting as shown in the Interagency Air Cartographic Committee (IACC) Specification IACC No. 4. These identification letters are shown on the Approach Lighting Legend Sheets published with Civil and Military Instrument Approach Procedures.

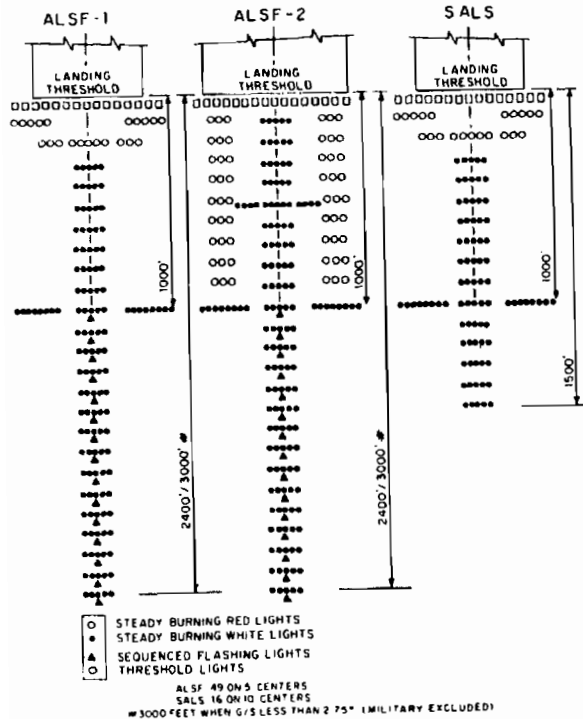

Figure 134 APPROACH LIGHTING SYSTEMS.

4. ALSF-2 (Type A). Approach Lighting System with Sequenced Flashing Lights.

a. System Description. The category II ALSF (ALSF-2) differs from the category I configuration only in the inner 1,000 feet (nearest the threshold) of the system. The outer 1,400 or 2,000 feet of both systems are identical. The 2,400-foot system is authorized by Order 6850.9

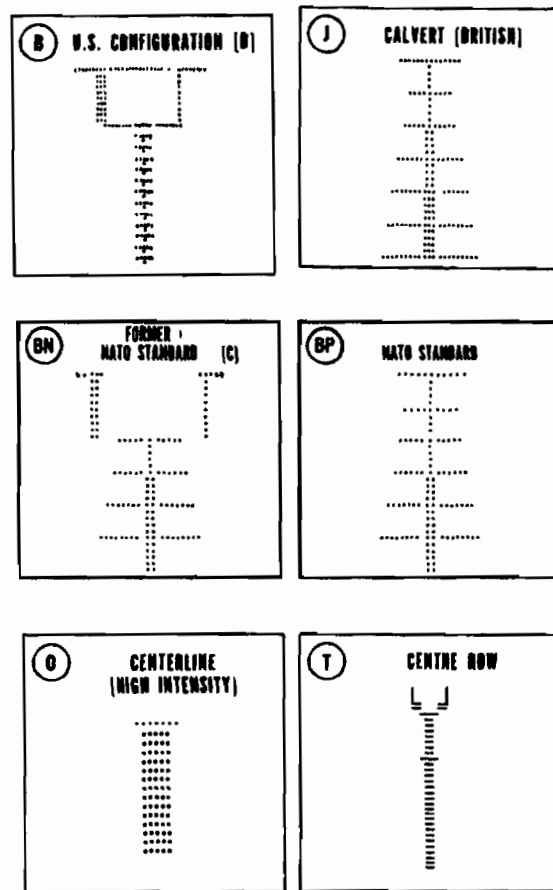

Figure 135. SYSTEMS EQUIVALENT TO U.S. STANDARD A,, ALSF-I

when the glide slope angle is 2.75° or higher, while the 3,000-foot system is authorized when the glide slope angle is less than 2.75°. The terminating bar and wingbars of the category I configuration are replaced with centerline bars of five white lights each. In addition, there are lightbars (three red lights each) on either side of the centerline bars at each light station in the inner 1,000 feet. These are called siderow bars. Also there is an additional bar 500 feet from the threshold. These lights form a crossbar referred to as the 500-foot bar. The category II configuration is shown in Figure 134.

b. Equivalent Systems. None.

* 5. SALS. (Type A₂) Short Approach Light System.

a. *System Description.* The Short Approach Light System is an installation which consists of the inner 1,500 feet of the standard ALSF-1 TYPE A₁ described in paragraph 3 of this appendix. The system provides roll guidance, a distinctive marker at 1,000 feet from the threshold, and distinctive threshold. See Figure 134.

NOTE: SALS is programed to be phased out or retrofitted.

b. *Equivalent Systems.* When the characteristics described in paragraph 5a exist in the following systems, the appropriate visibility reductions may be applied to MILITARY instrument approach procedures and to FAR 121 operations at foreign airports. See Figure 136.

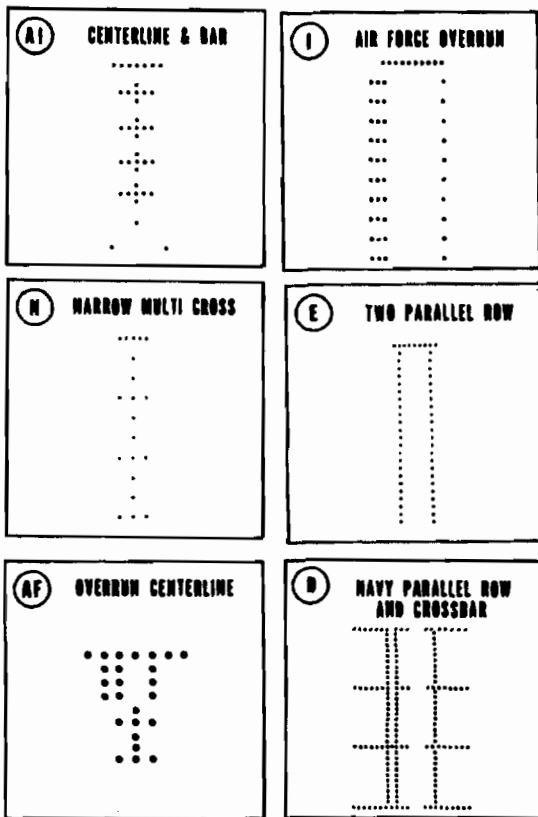

Figure 136. SYSTEMS EQUIVALENT TO SALS, SSALS, SSALF, MALS, AND MALSF.

Type Description

- AI Centerline and Bar (South America)
- I Air Force Overrun (U.S.)
- N Narrow Multi-Cross (British)
- E Two Parallel Rows (U.S.)
- AF Overrun Centerline High Intensity (Europe)
- D Navy Parallel Row and Crossbar (U.S.)

6. SSALS, SSALF, and SSALR. (Type A₃). Short Simplified Approach Lighting System; Short Simplified Approach Lighting System with Sequenced Flashers; and, Short Simplified Approach Lighting System with Runway Alignment Indicator Lights, respectively. See Figure 137.

NOTE: SSALS and SSALF are being phased out.

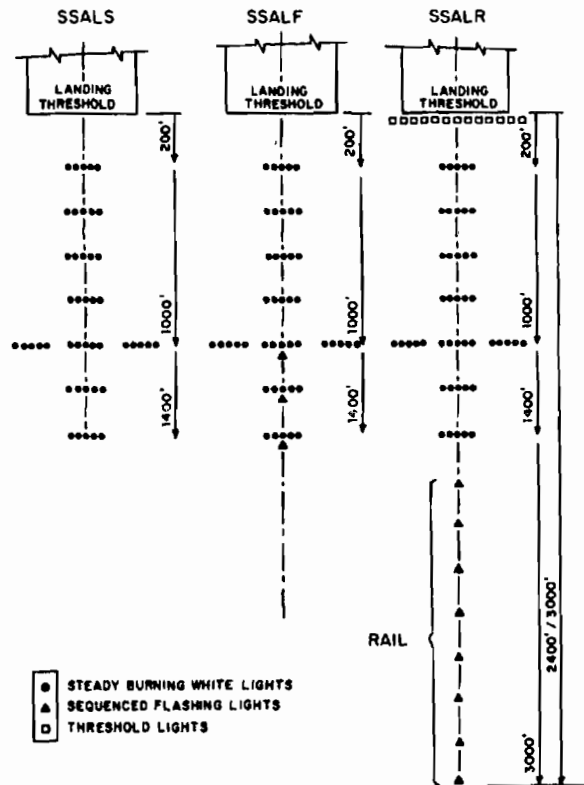

Figure 137. SIMPLIFIED SHORT APPROACH LIGHTING SYSTEMS

Appendix 5

* a. Systems Description.

(1) **SSALS.** The SSALS consists of seven five-light bars located on the extended runway centerline with the first bar located 200 feet from the runway threshold. Two additional five-light bars are located one on each side of the centerline bar, 1,000 feet from the runway threshold, forming a crossbar 70 feet long. All lights of the system are white.

(2) **SSALF.** The SSALF consists of a SSALS with three sequenced flashers that are located at the last three lightbar stations.

(3) **SSALR.** The RAIL portion of the SSALR consists of five or eight sequenced flashers located on the extended runway centerline. The first flasher is located 200 feet from the approach end of the SSALS with successive units located at each 200-foot interval out to 2,400 or 3,000 feet from the runway threshold.

b. Equivalent Systems.

(1) **SSALS and SSALF.** When the characteristics described in paragraphs 6a (1) and (2) exist in the systems shown in Figure 138, the appropriate visibility reduction may be applied to MILITARY instrument approach procedures.

(2) **SSALR.** When the characteristics described in paragraphs 6a (1) and (3) exist in the systems shown in Figure 138, the appropriate visibility reduction may be applied to MILITARY instrument approach procedures.

Type Description

- BQ Centre and Double Row RCAF Standard (Canada)
- BO Centre Row Modified Calvert (Canada)

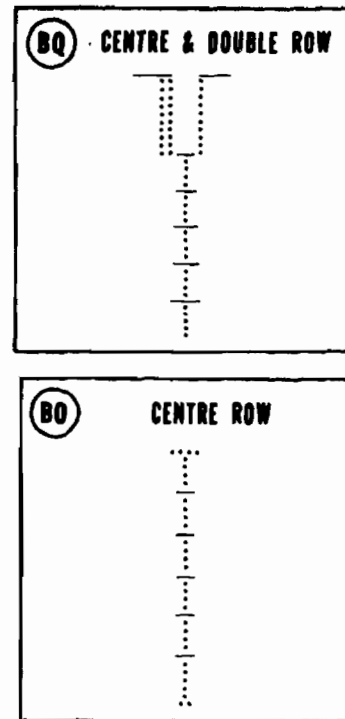

Figure 138. SYSTEMS EQUIVALENT TO SSALR AND MALSR.

7. **MALS, MALSF (Type A₄), and MALSR (Type A₅).** Medium Intensity Approach Lighting System; Medium Intensity Approach Lighting System with Sequenced Flashers; and, Medium Intensity Approach Lighting System with Runway Alignment Indicator Lights, respectively. See Figure 139.

a. Systems Description.

(1) **MALS.** The MALS consists of seven five-light bars located on the extended runway centerline with the first bar located 200 feet from the runway threshold and at each 200-foot interval out to 1,400 feet from the threshold. Two additional five-light bars, one on each side of the centerline bar, 1,000 feet from the runway threshold form a crossbar 66 feet long.

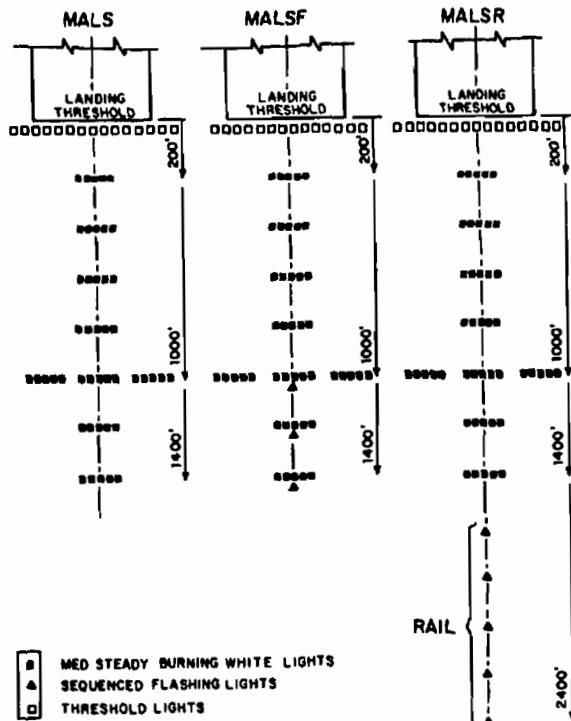

Figure 139. MEDIUM INTENSITY APPROACH LIGHTING SYSTEMS.

(2) MALSF. The MALSF consists of a MALS with three sequenced flashers located at the last three lightbar stations.

(3) MALSR. The RAIL portion of the MALSR consists of five or eight sequenced flashers located on the extended runway centerline. The first flasher is located 200 feet from the approach end of the MALS with successive units located at each 200-foot interval out to 2,400 feet from the runway threshold.

b. Equivalent Systems.

(1) MALS and MALSF. When the characteristics described in paragraphs 7a (1) and (2) exist in the systems shown in Figure 136, the appropriate visibility reductions may be applied to MILITARY instrument approach procedures.

(2) MALSR. When the characteristics described in paragraphs 7a (1) and (3) exist in the systems shown in Figure 138, the appropriate visibility reductions may be applied to MILITARY instrument approach procedures.

8. ODALS. Omnidirectional Approach Lighting System.

a. System Description. The system consists of seven strobe lights located in the approach area of a runway. Five of these strobes are located on the extended runway centerline starting 300 feet from the runway landing threshold and each 300-foot interval out to and including 1,500 feet from the threshold. The other two strobes are located on the sides of the runway threshold. The strobe lights flash in sequence toward the runway at a rate of once per second with the two units located at the runway end flashing simultaneously. The strobes have three intensity steps. See Figure 140.

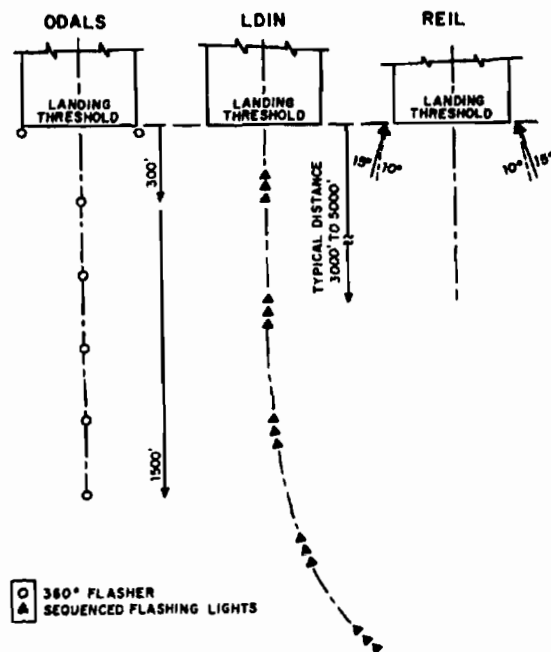

Figure 140. OMNIDIRECTION, LEAD-IN, AND RUNWAY END IDENTIFIER LIGHTING SYSTEMS

b. Equivalent Systems. When the characteristics described in paragraph 8a exist in the systems shown in Figure 141, the appropriate visibility reductions may be applied to MILITARY instrument approach procedures.

* **Type Description**

- BC Left Single Row (Canada)
- BR Centre Row RCAF (Canada)
- S Cross (Europe-Africa)
- M Single Row Centerline
(Europe-Asia-South America)
- BF Centre Row RCAF (Canada)
- X Centerline, Two Crossbars
(Europe-Africa)

b. *Equivalent Systems.* The Hong Kong Curve (British), Type BE, is equivalent to the LDIN system. See Figure 142.

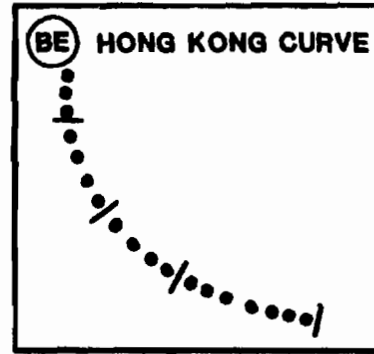

Figure 142. SYSTEM EQUIVALENT TO LDIN.

9. LDIN, Lead-In Lighting System.

a. *System Description.* The LDIN is usually installed as a supplement to a MALS or SSALS. This portion of the facility consists of a number of sequenced flashing lights beginning at a distance from the threshold determined by the need and terrain. These lights flash twice per second in sequence toward the threshold, have no intensity control, and operate on all brightness steps of the controlling system. The LDIN configuration is shown in Figure 140.

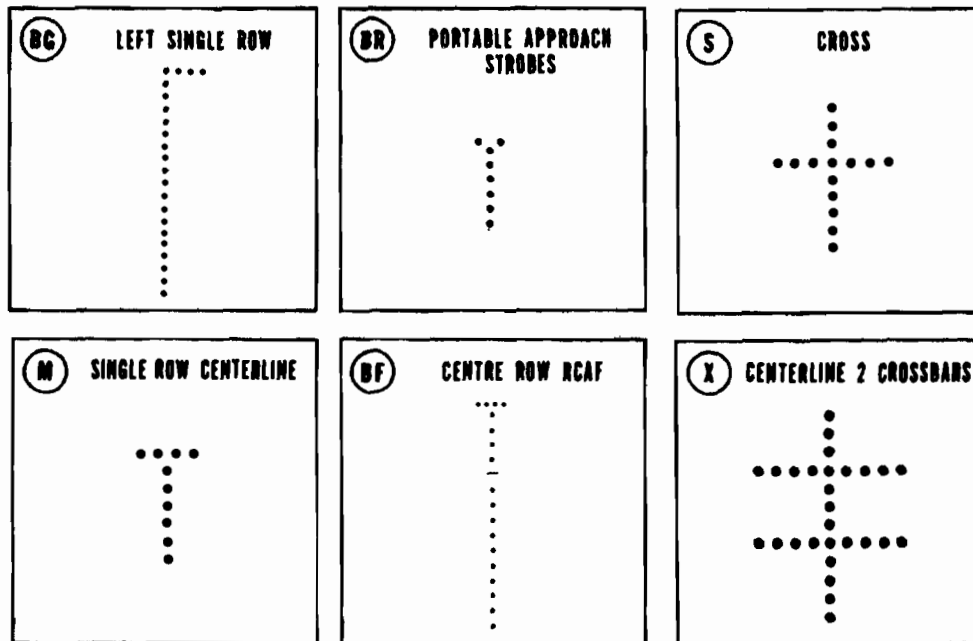

Figure 141. SYSTEMS EQUIVALENT TO U.S. ODALS paragraph 8, appendix 5.

* **10. REIL.** The Runway End Identifier Lights consist of a pair of condenser discharge fixtures identical to the sequenced flasher light system. The optimum location for the fixtures is at the runway threshold, 40 feet out on each side, measured from the runway edge. See Figure 140.

11. HIRL. High Intensity Runway Lights are used to outline the edges of paved runways during periods of darkness and low visibility. The light units are elevated and equipped with lenses which project two main light beams. Standards for design, installation, and maintenance are found in AC-150/5340-24.

12. MIRL. Medium Intensity Runway Lights are elevated and omnidirectional fixtures, with clear lenses. They may be used to light paved runways or unpaved landing strips. Standards for design, installation, and maintenance may be found in AC-150/5340-24.

13. TDZ/CL. Runway Centerline and Touchdown Zone Lighting. This system consists of touchdown zone lights and runway centerline lights. In the touchdown zone, two rows of transverse lightbars are located symmetrically about the runway centerline. The bars are spaced longitudinally at 100-foot intervals. Each lightbar consists of three unidirectional lights facing the landing threshold. The rows of lightbars extend to a distance of 3,000 feet, or one-half the runway length for runways less than 6,000 feet, from the threshold with the first lightbar located 100 feet from the threshold. The runway centerline lighting system consists of bidirectional fixtures installed at 50-foot intervals along the entire length of the runway centerline. The last 3,000-foot portion of the lighting system is color coded to warn pilots of the impending runway end. Alternate red and white lights are installed as seen from 3,000 feet to 1,000 feet from the runway end, and red lights are installed in the last 1,000-foot portion. Installation details may be found in AC 150/5340-4C.

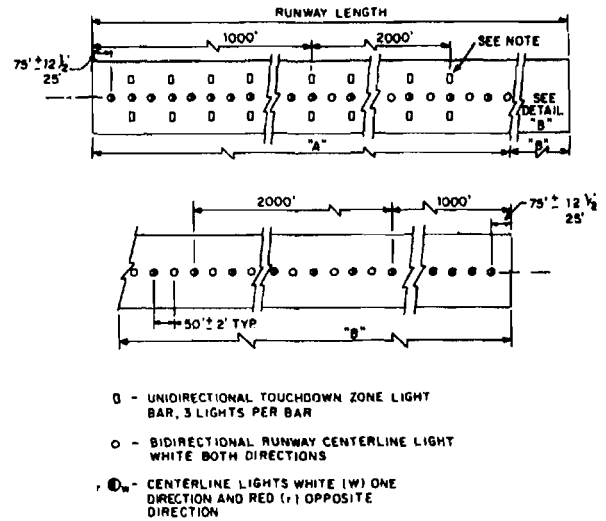

Figure 143. TOUCHDOWN ZONE CENTERLINE LIGHTS. *

THIS PAGE INTENTIONALLY LEFT BLANK

ALPHABETICAL INDEX

Adjustment of DH, ILS	938
Adjustment of DH, PAR (Hell)	1167
Adjustment of DH, PAR	1028
Adjustment to MDA	323
Air Force Procedures Issuance	171
Air Traffic, Coordination of Procedures	150
Alrborne Radar	1000, 1060
Alrborne Receiver Performance	Foreword
Airport Surveillance Radar	See ASR
Airports, Requirements for Procedures	122
Airport Waypoint	1501, 1506
Airspace Action, Coordination of Procedures	150
Airspeeds, Units Used	210
Air-ground Communications Required	122
Alignment of Initial Approach Segments	232
Alignment Options, NDB Final	613, 713
Alignment, Approach Course	342
Alignment, Arc Initial Course	232
Alignment, Arc Intermediate Approach Segment	243
Alignment, ASR Diverse Vectors	1041
Alignment, ASR Final	1044
Alignment, ASR Initial	1041
Alignment, ASR Intermediate	1042
Alignment, Circling Final Approach Area	260
Alignment, DF Final	813
Alignment, DR Initial Approach Segment	233
Alignment, Final Approach, VOR	413, 423
Alignment, Holding	291
Alignment, ILS Final	930
Alignment, Initial and Intermediate Segments	232
Alignment, Localizer	952
Alignment, Missed Approach	271
Alignment, NDB Final Approach	613, 623, 713
Alignment, PAR Final	1020
Alignment, Procedure Turn Initial Approach Segment	234
Alignment, RNAV Final	1523
Alignment, RNAV Initial	1521
Alignment, RNAV Intermediate	1522
Alignment, SDF Final Approach	1413
Alignment, Straight Initial Course	232
Alignment, Straight Intermediate Approach Segments	242
Alignment, TACAN Arc Final	523
Alignment, Teardrop Penetration Initial Approach	235
Alignment, VDP	251
Alignment, VOR Final	513
Alignment, VORTAC Arc Final	523
Alignment, VOR/DME Arc Final	523
Alongtrack Distance Fix	1501

Alongtrack Fix Displacement	1501, 1520
ALS for ILS Category II	A5-2
ALSF-1	341
ALS	A5-1
Alternate Minimums	360
Alternate Missed Approach Procedure	270
Altitude Difference, Procedure Turn Completion	234
Altitude Loss, Penetration Turn Initial Approach	235
Altitude Selection	231
Altitude Selection, ASR	1043
Altitude Selection, ILS	924
Altitude Selection, Initial Approach	231
Altitude Selection, Intermediate Approach	241
Altitude Selection, PAR	1016
Altitude Selection, Simultaneous ILS	994
Altitudes (Heli.)	1126
Altitudes, Emergency Safe	221
Altitudes, Minimum Safe	221
Altitudes, Minimum Sector	221
Altitude, Initial, ILS	924
Altitude, Intermediate Approach	924
Altitude, Minimum Descent	See MDA
Altitude, Minimum Safe, DF	810
Altitude, Minimum Sector	221
Altitude, Minimum, Initial Approach	231
Altitude, Missed Approach	270
Altitude, Penetration Turn	423, 924
Altitude, Penetration Turn, DF	813
Altitude, Procedure Turn Completion	234
Altitude, Procedure Turn, DF	813
Altitude, Procedure Turn, ILS	924
Altitude, Procedure Turn, NDB	613, 623
Altitude, Units Used	210
Ambiguity - Cone	1502
Analysis of Obstacle Clearance	A2-12
Angle of Convergence, NDB Final	613
Angle of Divergence	A1-2
Angle of Divergence, Holding Fix	287
Angle of Divergence, Teardrop Procedure Turn	234
Angle of Interception, Initial and Intermediate Segments	232
Angle of Interception, Simultaneous ILS Localizer	994
Angle of Intercept, DR Initial Segment	233
Angle of Intercept, PAR	1014
Angle of Intersection, ILS	923
Angles, Minimum Divergence	1760
Angle, Glide Slope, PAR	1026
Angle, ILS Glide Slope	936
Antenna Mast Height, ILS	936
Application of Appendix	A1-1
Application of Approach Category	213
Application (Heli.)	1106, 1125

Application, Departure Criteria	1201
Application, Turning Area Criteria	1714
Approach Categories (Hell.)	1108
Approach Categories	212
Approach Category Application	213
Approach Course Alignment	342
Approach Lights, Visibility Credit	340
Approach Minimums, DF	830
Approach Segments, Typical	230, 240
Approach Surface Baseline	A1-2, A2-9, A2-11
Approach, Circling	4, 260
Approach, Final	250
Approach, Initial	See Initial Approach
Approach, Intermediate	See Intermediate Approach
Approach, Light Plane	A1-1
Approach Lighting Systems	A5-1
Approach, Missed	See Missed Approach
Approach, NDB	See NDB
Approach, Precision	5
Approach, Procedures	5
Approach, Simultaneous	5
Approach, Straight-in	5
Approval of Procedures122
Approval, Nonstandard Procedures141
Approving Authority	A1-2
Arc Final Approach Segment Alignment, TACAN, VOR/DME and VOR with FAF (Hell.)	1137
Arc Final Approach Segment Radius, TACAN, VOR/DME and VOR with FAF (Hell.)	1136
Arc Final Approach, TACAN	523
Arc Final Approach, VORTAC	523
Arc Final Approach, VOR/DME	523
Arc, DME	A1-2
Arc, Initial Approach	232
Arc, Intermediate Approach Segment	240, 243
Area, Arc Intermediate Approach Segment	243
Area, ASR Final	1044
Area, ASR Initial	1041
Area, ASR Intermediate	1042
Area, Circling Approach	A1-2, 260
Area, Departure	1202, 1203
Area, DF Final	813
Area, Diverse Vectors, ASR	1041
Area, DR Initial Approach Segment	233
Area, Final Approach, VOR	413, 423
Area, ILS Final	930
Area, Initial Approach Segment	232
Area, Intermediate (with Procedure Turn)	244
Area, Localizer & LDA Final	953
Area, Missed Approach, ILS	944
Area, NDB Final Approach	613, 623
Area, Obstacle Clearance, En Route	1710, 1711, 1712
Area, Obstacle Clearance, Holding	292

Area, Obstacle Clearance, NDB	713
Area, Obstacle Clearance, VOR	513
Area, PAR Final	1020
Area, PAR Missed Approach	1033
Area, Procedure Turn	234
Area, RNAV Final	1523
Area, RNAV Initial	1521
Area, RNAV Intermediate	1522
Area, SDF Obstacle Clearance	1413
Area, Straight Intermediate Approach Segment	242
Area, TACAN Arc Final	523
Area, Teardrop Penetration Initial Approach	235
Area, Turning Missed Approach	275
Area, VDP	251
Area, VORTAC Arc Final	523
Area, VOR/DME Arc Final	523
Army Procedures Issuance	171
ARSR Fixes	283
ARSR, Use as Course Vector	283
ASR Fixes	283
ASR Procedures	1000, 1040
ASR, Use as a Course Vector	211
ATD Fixes, Use	1502
Authorities, Approving	Forward, A1-2
Back Course Procedures, SDF	1415
Baseline, Approach Surface	A1-2, A2-9, A2-11
BC	A1-2
Bearings, Units Used	210
Cancellation of Directives	2
Cancellation of Procedures	123
Categories of Aircraft for Approach	212
Ceiling, Departure	1208
Changeover Points (COP), En Route	1716
Changes to Procedures	142
Circling Alignment, VOR	513
Circling Approach Area Not Considered for Obstacle Clearance	261
Circling Approach Area	A1-2
Circling Approach Minimums	323
Circling Approach, Missed Approach Point	514
Circling Approach, NDB	613, 713
Circling Approach, SDF	1413
Circling Approach, VOR	400, 413
Circling Descent Gradient	513
Circling Descent Gradient, NDB Final	713
Circling Final Approach	260
Circling Minimums	322, 351
Circling NDB Approach	600
Circling NDB Missed Approach	714
Circling NDB Obstacle Clearance	613
Circling NDB Procedures	600
Circling Obstacle Clearance, ASR	1044

Circling Obstacle Clearance, NDB 623
 Circling Obstacle Clearance, VOR 413, 423, 513
 Circling Procedures Identification 162
 Circling 4
 Civil Airport Procedures Responsibility 130
 Civil Airports, Coordination of Procedures 150
 Civil Procedures Issuance 171
 Civil Procedures, Coordination Conflicts 151
 Civil Takeoff Minimums 370
 Clearance, Obstacle See Obstacle Clearance
 Climb Gradients, Departure 1205
 Coast Guard Procedures Issuance 171
 Combination Missed Approach Obstacle Clearance 277
 Combination Missed Approach, ILS 945
 Combination Missed Approach, PAR 1035
 Combination Missed Approach, RNAV 1535
 Combination Straight and Turning Missed Approach PAR (Hell.) 1171
 Combination Straight and Turning Missed Approach (Hell.) 1122
 Common Information 210
 Communications for PAR 1012
 Communications in Holding 1731
 Communications Loss for ASR 1047
 Communications Required for Procedures 122
 Communications, DF Procedure 820
 Compass Locator 911
 Component Failure, PAR 1011
 Components, ILS Cat I 910
 Components, ILS 913
 Computing TCH A2-9
 Cone of Ambiguity 1502
 Construction of Procedure 214
 Controlling Obstacle A1-2
 Convergence Angle, NDB Final 613
 Convergence NDB Final 713
 Coordination Conflicts 151
 Coordination of Procedures 123, 150, 172
 Course Change, En Route 1717
 Course Divergence, Penetration Turn Initial Approach 235
 Course Reversal, RNAV 1521
 Course, Straight, Initial Approach, Angle of Intersection 232
 Course, Units Used 210
 Criteria, ILS Category I 920
 Crosstrack Fix Displacement 1501
 Dead Reckoning Initial 233
 Dead Reckoning A1-2
 Decision Height See DH
 Definition of ILS Type 901
 Departure Ceiling 1208
 Departure Minimums 370, 1280
 Departure Procedure Publication 1207
 Departure Procedures 4, 1200

Departure Routes	1203, 1205
Departure Visibility	1208
Departures Straight	1203
Departures, Turning	1203
Departure, End of	1206
Descent Altitude, Minimum	See MDA
Descent Angle, RNAV	1523
Descent Fix Distance	288
Descent Fix	288
Descent Gradient	513
Descent Gradient, Approach Segment	288
Descent Gradient, Arc Initial Segment	232
Descent Gradient, ASR	1044
Descent Gradient, ASR Diverse Vectors	1041
Descent Gradient, ASR Initial	1041
Descent Gradient, ASR Intermediate	1042
Descent Gradient, DR Initial Segment	233
Descent Gradient for Final Approach	252
Descent Gradient (Hell.)	1110
Descent Gradient, ILS	923
Descent Gradient, Initial Approach Area	232, 235
Descent Gradient, Intermediate Approach Segment	243
Descent Gradient, Localizer & LDA Final	955
Descent Gradient, NDB	623, 713
Descent Gradient, PAR	1015
Descent Gradient, Procedure Turn Initial Approach	234
Descent Gradient, RNAV Initial	1521
Descent Gradient, RNAV Intermediate	1522
Descent Gradient, Straight Intermediate Segment	242
Descent Gradient, TACAN Arc Final	523
Descent Gradient, VOR Final	423
Descent Gradient, VORTAC Arc Final	523
Descent Gradient, VOR	413
Descent Gradient, VOR/DME Arc Final	523
Deviation from Established Radar Patterns	1045
DF Procedures	800, 810
DF & High Altitude Penetration	A2-8
DH Adjustment, PAR	1028
DH	324, A1-2
DH, ILS	938
DH, PAR	1028
Discontinuance of ILS Missed Approach Obstacle Clearance	944
Discontinuance of PAR Missed Approach Obstacle Clearance	1034
Displacement, Fix	281, 284, 285, 286
Distance Effect on Visibility Minimums	331
Distance & Bearing Information	210
Distance & Divergence, Penetration Turn	235
Distance, Units Used	235
Distance, DME	A1-2
Distance, Holding Fix Facility	287
Distance, Penetration Turn Initial Approach Area	235

Distance, Procedure Turn vs. Intermediate Segment	244
Distance, Procedure Turn	234
Distribution (FAA)	2
Distribution (U.S.A., USAF)	Page viii
Distribution (U.S.N., USMC, USCG)	Page vii
Divergence Angle, Holding Fix	287
Divergence Angle, Teardrop Procedure Turn	234
Diverse Departures	1202, 1205
Diverse Vectors, ASR	1041
DME Accuracy	286
DME Arc	A1-2
DME Distance	A1-2
DME Distance Waypoints	1505
DME Fixes	282
DME	912
Dogleg Segment, En Route	1716
Doppler, RNAV	1500, 1501
DR	232
Early Turns	1204, 1205
Effective Date of Procedure	172
Eligibility for Procedures	120
Eligibility, Civil Airports	120
Eligibility, Military	120
Elimination of Procedure Turn	234
Emergency Dissemination of Procedures	150, 172
Emergency Safe Altitude	221
End of Departure	1206
End of Missed Approach	278
End Point Waypoints	1505
En Route Holding	1731
En Route Obstacle Clearance Areas	1710
En Route Operations	220
En Route RNAV	1510
En Route Turning Areas	1510
Entry Zone, Procedure Turn	234
Equivalents to ALS	A5-2
Equivalents to LDIN	A5-8
Equivalents to MALS	A5-3
Equivalents to ODALS	A5-5
Equivalents to SALS	A5-3
Equivalents to SSALF	A5-3
Equivalents to SSALS	A5-3
Established GS Angle	A2-9
Establishment of Procedures	140
Existing Procedures	4
Expanded Turning Area, RNAV	1510
Facilities for which Criteria Are Not Provided (Heli.)	1104
FAC	A1-2
FAF	A1-2
Feeder Routes	220, 410, 420, 510, 520, 610, 620, 710, 730, 920, 950, 993, 1013
Feeder Routes, RNAV	1512

Appendix 6

Final Approach Alignment PAR (Hell.)	1159
Final Approach Area PAR (Hell.)	1160
Final Approach Fix Error	287
Final Approach Length, Effect on MDA	323
Final Approach NDB	613, 623
Final Approach Obstacle Clearance Surface	A2-11
Final Approach, RNAV	1523
Final Approach Secondary Area Obstacle Clearance	A2-7
Final Approach Secondary Area Width	A2-7
Final Approach Segment ASR (Hell.)	1174
Final Approach Segment ILS (Hell.)	1152
Final Approach Segment NDB with FAF (Hell.)	1142
Final Approach Segment NDB, No FAF (Hell.)	1140
Final Approach Segment on Heliport VOR (No FAF)(Hell.)	132
Final Approach Segment PAR (Hell.)	1158
Final Approach Segments	A2-11
Final Approach Segment	250
Final Approach Segment, Parallel ILS	996
Final Approach Segment, TACAN, VOR/DME and VOR with FAF (Hell.)	1133
Final Approach Segment, Visual Portion	251
Final Approach Segment, VOR (High ALT)	423
Final Approach Segment, VOR (Low ALT)	413
Final Approach Surface, PAR (Hell.)	1162
Final Approach Trapezoid, NDB	713
Final Approach (Hell.)	1116
Final Approach - Only One Specified	250
Final Approach, ASR	1044
Final Approach, DF	813
Final Approach, ILS	930
Final Approach, PAR	1020
Final Approach, SDF	1413
Final Approach, TACAN	523
Final Approach, VORTAC	523
Final Approach, VOR	513
Final Approach, VOR/DME	523
Final Secondary Area	A2-6
Fix Displacement, RNAV	1502
Fix Distance, Descent	288
Fix Error, Final Approach	287
Fix Formed by Intersection	281
Fix Stepdown, NDB	613, 623
Fixes, LF	1762
Fixes, NDB Final	713
Fixes, Radar	283
Fixes, TACAN Arc Final	523
Fixes, Use of	513
Fixes, VHF, En Route	1761
Fixes, VORTAC Arc Final	523
Fixes, VOR/DME Arc Final	523
Fix, Descent	288
Fix, Displacement	281, 284, 285, 286

Fix, DME	282
Fix, Holding	287
Fix, Initial Approach	230, 287
Fix, Intermediate	287
Fix, Obstacle Clearance	288
Fix, Obstacles Close-in	289
Fix, Stepdown	288
Fix, Terminal Area	280
Flight Inspection	A1-2
Flight Levels, Units Used	210
Formulation of Procedures	140
Gaps, Navigational	1740
Glide Slope Extension	A2-9
Glide Slope, ILS	936
Glide Slope, PAR (Heli.)	1165
Glide Slope, PAR	1026
Glossary	A1-2
GPI	A1-2, A2-7
GPS, RNAV	1500, 1501
Gradient, Departure Climb	1205
Gradient, Descent	See Descent Gradient
Ground Point of Intercept	A2-11
Ground System Performance	Foreword
GS Angle	A2-9
GS Antenna Height, ILS	936
GS Antenna Location	A2-9
GS Relocation, ILS	937
GS Relocation, PAR	1027
Guidance, Positive, Course, Requirements	211
HAA	A1-2
HAT	A1-2
Height Antenna Mast, ILS	936
Height, Threshold Crossing, ILS	936
Helicopter Procedures	1100
High Altitude Penetrations	Chap 4, Sect 2
High Altitude Penetration	A2-8
High Altitude Procedures Identification	163
HIRL for RVR Approval	334
Holding	290
Holding Alignment (Heli.)	1123
Holding Area (Heli.)	1124
Holding at Initial Fix	230
Holding, En Route	1731
Holding Fix	287
Holding Obstacle Clearance Area	292
Holding Obstacle Clearance	293
Holding Obstacle Clearance, En Route	1731
Holding Pattern as Initial Segment	230
Holding Pattern Over Final Approach Fix	234
Holding Pattern Over Intermediate Fix	234
Holding Patterns	290

Holding, RNAV	1507
Holding Waypoints	1505
IAC	A1-2
IAF	A1-2
IAF, Initial Approach Fix	230
IC	A1-2
Identification of Procedures	160
IF	A1-2
ILS Category II ALS	A5-9
ILS Category III	970
ILS Category II	960
ILS Category I	901
ILS Criteria	920
ILS GS Angle vs. Slope of Surface	931
ILS Procedures, Simultaneous	990
ILS	900
ILS/PAR Obstacle Clearance	A2-11
Inertial RNAV	1500, 1501
Initial Altitudes, ILS	924
Initial and Intermediate Segments on Heliport VOR (No FAF)(Heli.)	1131
Initial Approach Altitude Selection	231
Initial Approach Area, Penetration Turn	235
Initial Approach Penetration Turn Altitude	235
Initial Approach Segment ASR (Heli.)	1172
Initial Approach Segment Based on Procedure Turn (Heli.)	1112
Initial Approach Segment Based on Procedure Turn	234
Initial Approach Segments Based on Straight Courses and Arcs with Positive Course Guidance (Heli.)	1111
Initial Approach Segment, VOR	411, 421, 511
Initial Approach	230
Initial Approach, ASR	1041
Initial Approach, DF	811
Initial Approach, ILS	921
Initial Approach, Localizer & LDA	950
Initial Approach, NDB	611, 621, 711
Initial Approach, RNAV	1521
Initial Approach, Simultaneous ILS	994
Initial Fix	287
Initial Secondary Area Obstacle Clearance	A2-5
Initial Segments	230
Initial Segment, PAR	1013
Initial Segment, TACAN	521
Initial Segment, VORTAC	521
Initial Segment, VOR/DME	521
Initiation of Missed Approach	270
Inoperative Components, ILS	913
Inoperative Components, PAR	1011
Instrument Landing System	See ILS
Intercept Angle, DR Initial Approach Segment	233
Interception Angle, Simultaneous ILS	994
Intermediate Approach Altitude	924

Intermediate Approach Segment ASR (Heli.)	1173
Intermediate Approach Segment Based on an Arc (Heli.)	1114
Intermediate Approach Segment Based on Straight Courses (Heli.)	1113
Intermediate Approach Segment ILS (Heli.)	1151
Intermediate Approach Segment PAR (Heli.)	1156
Intermediate Approach Segment, Arc	243
Intermediate Approach	240
Intermediate Approach, DF	812
Intermediate Approach, ILS	922
Intermediate Approach, NDB	612, 621, 712
Intermediate Approach, Straight	242
Intermediate Approach, VOR	412
Intermediate Fix	287
Intermediate RNAV	1522
Intermediate Secondary Area Obstacle Clearance	A2-4
Intermediate Secondary Area	A2-3
Intermediate Segment within a Procedure Turn Segment (Heli.)	1115
Intermediate Segment within a Procedure Turn Segment	244
Intermediate Segment, ASR	1042
Intermediate Segment, NDB	612
Intermediate Segment, PAR	1014
Intermediate Segment, Simultaneous ILS	995
Intermediate Segment, TACAN	522
Intermediate Segment, VOR (High ALT)	422
Intermediate Segment, VOR (Low ALT)	412
Intermediate Segment, VORTAC	522
Intermediate Segment, VOR/DME	522
Intermediate, Localizer & LDA	950
Intersection Angle, Arc Initial Approach	232
Intersection Angle, ILS	923
Intersection Angle, Initial to Intermediate Segments	232
Intersection Angle, Straight Initial Segment	232
Intersection Fix Displacement	285
Intersection Fix	281
Issuance of Procedures	171
JAL	A1-2
Jurisdiction of Procedures	131
Landing Systems, Instrument	See ILS
Lateral Distance of GS Antenna	A2-9
Latitude/Longitude Waypoints	1505
LDA Procedures	950
LDA	901, A1-2
LDIN	341, A5-8
Lead Radial, Arc Initial Approach Segment	232
Lead Radial, Arc Initial Segment	232
Length, Arc Intermediate Approach Segment	243
Length, ASR Final	1044
Length, ASR Intermediate	1042
Length, DR Initial Approach Segment	233
Length, Final Approach Segment, VOR	513
Length, ILS Final Approach Area	930

Length, Initial Approach Segment	232
Length, Intermediate Segment (with Procedure Turn)	244
Length, Intermediate, ILS	923
Length, NDB Final Approach Course	713
Length, PAR Final	1020
Length, Straight Intermediate Approach Segment	242
Lighting Required for Procedures	122
Lighting Systems	341
Lighting & Marking Obstacles	122
Lighting, Approach	A5-1
Lights, Visibility Credit	340
LMM	911
Localizer Accuracy	285
Localizer and LDA (Hell.)	1155
Localizer Approach	901
Localizer Interception, Simultaneous ILS	994
Localizer Only, Use	951
Localizer Procedures	950
Location of GS Antenna	936, A2-9
LOC	A1-2
LOM	911
Loran-C	1500, 1501
Lost Communications, ASR	1047
Low Altitude NDB Procedures	610
Low Altitude Procedures, VOR	410
Lowest Minimums, ILS	935
MALSR	341, A5-10
MALS	341, A5-6
Maneuvering Zone, Procedure Turn	234
MAP	A1-2
MAP, ILS	941
MAP, NDB	714
MAP, PAR	1031
MAP, VOR	514
Marker Beacon Accuracy	286
Marking of Runways	342
Marking & Lighting Obstacles	122
Maximum Intermediate Segment Length (with Procedure Turn)	244
MCAs	1730
MDA Adjustment	323
MDA Effect on Visibility Minimums	331
MDA for Circling Approach	322, 351
MDA for Straight-in Approach	321
MDA	320, 513, A1-2
MDA, Arc Procedures	523
MDA, DF	813
MDA, Localizer & LDA	956
MDA, NDB Procedures	613, 623, 713
MDA, VOR	413, 423
Measurement, Units of	210
MEAs	1718

MHA	A1-2
Microwave ILS (Heli.)	1154
Military Airports, Coordination of Procedures	150
Military Airports, Procedures Responsibility	130
Military Minimums	350
Military Procedures at Civil Airports, Responsibility	130
Military Procedures, Nonstandard	141
Military Takeoff Minimums	370
Minimum Altitude, Intermediate Segment	241
Minimum Arc Radius, Initial Approach	232
Minimum Crossing Altitude (MCA)	1730
Minimum Descent Altitude	See MDA
Minimum DH, ILS	938
Minimum DH, PAR	1028
Minimum Divergence Angles	1760
Minimum En Route Instrument Altitudes (MEA)	1718
Minimum Length of NDB Final Approach Segment	713
Minimum Length, Intermediate Course	242
Minimum Obstacle Clearance in Initial Approach	235
Minimum Safe Altitude	221
Minimum Safe Altitude, DF	810
Minimum Sector Altitude	221
Minimum Straight Intermediate Course Length	242
Minimums, Alternate	360
Minimums, Approach, Aircraft Category Descriptions	212
Minimums, Circling	351
Minimums, Departure	370, 1208
Minimums, DF	830
Minimums, Establishment	310
Minimums, ILS	935
Minimums, Military	350
Minimums, PAR Final	1025
Minimums, Standard	350
Minimums, Takeoff & Landing	300
Minimums, Takeoff	370
MIRL	A5-13
Missed Approach Alignment	271
Missed Approach Area ILS (Heli.)	1153
Missed Approach Area, Combination	277
Missed Approach ILS, Combination	945
Missed Approach Obstacle Clearance	274
Missed Approach Obstacle Clearance, ILS	944
Missed Approach Obstacle Clearance, PAR (Heli.)	1168
Missed Approach Obstacle Clearance, PAR	1034
Missed Approach Point (Heli.)	1117
Missed Approach Point	272
Missed Approach Point, ASR (Heli.)	1175
Missed Approach Point, NDB with FAF (Heli.)	1143
Missed Approach Point, RNAV	1532
Missed Approach Point, TACAN, VOR/DME and VOR with FAF (Heli.)	1135
Missed Approach Segment	514, 524

Missed Approach 40:1 Surface	274
Missed Approach	270
Missed Approach, ASR	1048
Missed Approach, DF	814
Missed Approach, End	278
Missed Approach, ILS	940, 942, 943
Missed Approach, Localizer & LDA	957
Missed Approach, NDB	614, 624, 714
Missed Approach, Overhead a Fix	287
Missed Approach, RNAV	1530, 1531
Missed Approach, SDF	1414
Missed Approach, Simultaneous ILS	997
Missed Approach, VOR	413, 424, 514
Mountainous Areas, En Route	1720
Multi-Sensor RNAV	1500, 1501
Navigation Facility, Requirement for Procedures	122
Navigational Gaps	1740
Navy & Marine Corps Procedures Issuance	171
NDB Procedures	600, 700, 710
NDB	A1-2
No Transgression Zone, Simultaneous ILS	996
Nonprecision Approach	5
Nonprecision Approach Minimums	330
Nonprecision	A1-2
Nonstandard Lighting Systems	344
Nonstandard Procedures	141
Notams, Use for Procedures	150, 172
Obstacle Clearance Analysis	A2-10
Obstacle Clearance Areas, En Route	1710
Obstacle Clearance Areas, Penetration Turn Initial Approach	235
Obstacle Clearance Area, Holding	292
Obstacle Clearance Area, NDB	713
Obstacle Clearance Area, VOR	513
Obstacle Clearance Boxes	A1-2
Obstacle Clearance Criteria, ILS/PAR	A2-10
Obstacle Clearance PAR (Hell.)	1164
Obstacle Clearance Past a Fix	288
Obstacle Clearance	342, A1-2
Obstacle Clearance, Arc Intermediate Segment	243
Obstacle Clearance, ASR Diverse Vectors	1041
Obstacle Clearance, ASR Initial	1041
Obstacle Clearance, ASR Intermediate	1042
Obstacle Clearance, ASR	1044
Obstacle Clearance, Circling Final Approach	260
Obstacle Clearance, DF Final	813
Obstacle Clearance, DR Initial Segment	233
Obstacle Clearance, Emergency Safe Altitude	221
Obstacle Clearance, En Route	1720, 1721
Obstacle Clearance, En Route RNAV	1510, 1511
Obstacle Clearance, Facility Sectors	221
Obstacle Clearance, Final Approach Secondary	A2-7

Obstacle Clearance, Holding	293
Obstacle Clearance, ILS	934
Obstacle Clearance, Initial Approach Area	232
Obstacle Clearance, Initial Secondary Area	A2-5
Obstacle Clearance, LF	1750
Obstacle Clearance, Localizer & LDA Final	954
Obstacle Clearance, Minimum Safe Altitude	221
Obstacle Clearance, Minimum Sector Altitude	221
Obstacle Clearance, Missed Approach, ILS	944
Obstacle Clearance, NDB Final	613, 713
Obstacle Clearance, NDB	623
Obstacle Clearance, PAR Final	1024
Obstacle Clearance, PAR Missed Approach	1034
Obstacle Clearance, Penetration Turn Initial Approach	235
Obstacle Clearance, Procedure Turn Initial	234
Obstacle clearance, RNAV Feeder	1512
Obstacle Clearance, RNAV Final	1523
Obstacle Clearance, RNAV Initial	1521
Obstacle Clearance, RNAV Intermediate	1522
Obstacle Clearance, SDF	1413
Obstacle Clearance, Secondary Area	A2-4, A2-5, A2-7
Obstacle Clearance, Sector, DF	810
Obstacle Clearance, Straight Intermediate Approach Segment	242
Obstacle Clearance, Straight Missed Approach	274
Obstacle Clearance Surface, VDP	251
Obstacle Clearance, TACAN Arc Final	523
Obstacle Clearance, Turning Missed Approach	276
Obstacle Clearance, VDP	251
Obstacle Clearance, VORTAC Arc Final	523
Obstacle Clearance, VOR	413, 513
Obstacle Clearance, VOR/DME Arc Final	523
Obstacle Identification Surface (OIS)	1202, 1203
Obstacle Marking & Lighting	122
Obstacle Problems	A2-2
Obstacles Close-in to Fix	289
Obstacles, Secondary Areas	A2-2
Obstacle	A1-2
Obstacle, Controlling	A1-2
Offset COP, En Route	1716
Off-Airport Facilities, Missed Approach	514
Omega, RNAV	1500, 1501
On-Airport Facilities, Missed Approach Point	514
On-Airport VOR, No FAF	400
Operational Advantage	A1-2
Optimum	A1-2
PAR Missed Approach	1030
PAR Procedures	1010
PAR System Components	1010
PAR	1000
PAR, Simultaneous	1050
Penetration Turn Altitude, DF	813

Penetration Turn Altitude, Initial Approach	235
Penetration Turn Altitude, VOR	423
Penetration Turn Distance vs. Divergence	235
Penetration Turn Initial Approach Obstacle Clearance	234
Penetration Turn Table	235
Penetration Turn, ILS	924
Penetration Turn, NDB	623
Penetration Turn, VOR	423
Penetrations as Initial Segments	230
Pilotage Error Standards	Foreword
Point in Space Approach (Hell.)	1107
Positive Course Guidance for Final Approach	250
Positive Course Guidance in Missed Approach	273
Positive Course Guidance, Requirements	211
Positive Course Guidance, RNAV	1502
Precipitous Terrain, Effect on MDA	323, A1-2
Precision Approach Minimums	323
Precision Approach Radar	See PAR
Precision Approach	5, A1-2
Primary Areas, En Route	1711
Primary Area	A1-2
Primary Area, RNAV	1510
Private Procedures, Eligibility	120
Procedure Construction (Hell.)	1109
Procedure Construction	214
Procedure Identification (Hell.)	1105
Procedure Segments	214
Procedure Turn Altitude, DF	813
Procedure Turn Altitude, NDB	613
Procedure Turn Altitude, VOR	413
Procedure Turn Area	234
Procedure Turn as Initial Segment	230
Procedure Turn Completion Altitude Difference	234
Procedure Turn Distance	234
Procedure Turn, Elimination	234
Procedure Turn, ILS	924
Procedure Turn, Initial Descent Gradient	234
Procedure Turn, Point of Origin	234
Procedure Approval	122
Procedures Cancellation	123
Procedures, Airport Requirements	122
Procedures, Changes to	142
Procedures, Communications Required	122
Procedures, Coordination	123, 130, 150, 172
Procedures, Departure	5
Procedures, Dissemination by Notam	150, 172
Procedures, Effective Date	170
Procedures, Eligibility	120
Procedures, Emergency Dissemination	150, 172
Procedures, Formulation	140
Procedures Identification	160

Procedures, Issuance	171
Procedures, Jurisdiction	131
Procedures, Lighting Required	122
Procedures, Military, Nonstandard	141
Procedures, Navigation Facility Requirement	122
Procedures, NDB	See NDB
Procedures, Nonstandard	141
Procedures, Notams for	150
Procedures, Obstacle Marking & Lighting	122
Procedures, Obstructions to	122
Procedures, Publication	170
Procedures, Requests	121
Procedures, Responsibility	130
Procedures, Retention	123
Procedures, Submission	170
Procedures, Types	5
Procedures, Weather Information Required	122
Procedure, Missed Approach	270
Publication of Departure Procedures	1207
Publication of Minimums	311
Publication of Procedures	170
Purpose of TERPS	1
Radar Accuracy	286
Radar Fix	283
Radar Monitor	1046
Radar Pattern Deviation ASR	1045
Radar Patterns, ASR	1041
Radar Procedures	1000
Radar, Airborne	1060
Radar, Airport Surveillance	See ASR
Radar, Precision Approach	See PAR
Radial Final Approach, TACAN	523
Radial Final Approach, VORTAC	523
Radial Final Approach, VOR/DME	523
Radial Intermediate Segment	240
Radials, Units Used	210
Radius, Arc Intermediate Approach Segment	243
Radius, Arc, Initial Segment	232
Random Routes	1501
Random Vector	A1-2
Range, Runway Visual	See RVR
Reckoning, Dead	A1-2
Reference Facility	1501, 1502, 1504
References	A3-5
REIL	A5-11
Relocation of GS, PAR	1027
Relocation of the Glide Slope PAR (Hell.)	1166
Remote Altimeter Source, Effect on MDA	323
Requests for Procedures	121
Responsibility for Procedures	130
Retention of Procedures	123

Review, Annual	Foreword
Rho-Rho, RNAV	1500, 1501
RNAV Descent Angle	1501
RNAV - General	1500
RNAV Procedure Construction	1502
RNAV Procedure Identification	1503
RNAV Routes	1501
ROC	A1-2, A2-4, A2-9
Rounding MDA	321, 322
Route Change Waypoints	1505
Routes, Departure	1203, 1205
Route Width, RNAV	1502
Runway Environment	A1-2
Runway Lights for RVR Approval	334
Runway Markings	334, 342
Runway Requirements	334
Runway Separation, Parallel ILS	992
Runway Visual Range	See RVR
Runway Waypoint	1501, 1506
RVR Approval, Runway Requirements	334
RVR Substitute Values	335
RVR Units Used	210
RVR	333
SALS	A5-3
Scope of TERPS	1
SDF Procedures	1400
Secondary Area Obstacle Clearance, Final Approach	A2-7
Secondary Area Obstacle Clearance, Initial	A2-5
Secondary Area Obstacle Clearance, Intermediate	A2-4
Secondary Area Width, Final Approach	A2-6
Secondary Areas	A1-2, A2-1, A2-3
Secondary Areas, En Route	1712
Secondary Area, Missed Approach, ILS	944
Secondary Area, RNAV	1510
Sector Altitudes, Minimum	221
Segment	A1-2
Segment Length, PAR	1014
Segments of a Procedure	214
Segment, Initial	230
Segment, Intermediate Approach	240
Segments, RNAV	1502
Selection, Altitude	231
Service Volume	A1-2
Simultaneous Approach	5
Simultaneous ILS Procedures	990
Simultaneous ILS	901
Simultaneous PAR	1050
Simultaneous Radar Procedures	1000
Size-Circling Final Approach Area	260
Size, Penetration Turn Initial Approach Area	235
Slope, ILS Surfaces	931

Special Procedures Cancellation	123
Speeds, Units Used	210
SSALF	341, A5-4
SSALS	341, A5-4
Standard ALS	A5-1
Standard Lighting System	341
Standard Minimums	350
Station Elevation, RNAV	1505
Station Passage Fix Error	286
Stepdown Fix	288
Stepdown Fix, NDB	613, 623
Stepdown Fix, VOR	413, 423
Steps, MEA	1740
Straight Departures	1203
Straight Intermediate Approach Segment	242
Straight Line Extension of GS	A2-9
Straight Missed Approach Area (Hell.)	1118
Straight Missed Approach Obstacle Clearance (Hell.)	1119
Straight Missed Approach	273
Straight Missed Approach, ILS	942, 944
Straight Missed Approach, PAR (Hell.)	1169
Straight Missed Approach, PAR	1032, 1034
Straight Missed Approach, RNAV	1533
Straight-in Alignment VOR	513
Straight-in Alignment, NDB Final	613
Straight-in Approach Minimums	321
Straight-in Approach Missed Approach Point	514
Straight-in Approach	5
Straight-in Approach, VOR	400
Straight-in Descent Gradient	513
Straight-in Descent Gradient, NDB	713
Straight-in Final Approach Alignment, VOR	413, 513
Straight-in Final Approach, SDF	1413
Straight-in Minimums	330, 350
Straight-in NDB Alignment	613
Straight-in NDB Approach	600
Straight-in NDB Final	713
Straight-in NDB Missed Approach	714
Straight-in NDB Obstacle Clearance	613
Straight-in NDB Procedures	600
Straight-in Obstacle Clearance, ASR	1044
Straight-in Obstacle Clearance, NDB Final	713
Straight-in Obstacle Clearance, NDB	623
Straight-in Obstacle Clearance, VOR	413, 423, 513
Straight-in Procedures Identification	161
Submission of Procedures	170
Surface, ILS Final Approach	931
Surface, PAR Final	1021
System Accuracy Factors	Foreword
System Accuracy, En Route	1711, 1712
System Accuracy, Turning Areas	1713

System Components, ILS	910
System Components, PAR	1010
System Components, Simultaneous ILS	991
TACAN Procedures	500
TACAN RNAV Systems	1500, 1501
Takeoff Minimums (Hell.)	1129
Takeoff Minimums	370
Tangents	A4-1
Tangent Point	1501
Tangent Point Distance	1501
TCH	A2-9
TCH, ILS	936
TCH, PAR	1026
TDZ	A1-2, A5-7
Teardrop Penetration Initial Approach	235
Teardrop Penetration, VOR	420
Teardrop Procedure Turn, Angle of Divergence	234
Template, Turning Area	1715
Terminal Area Fixes	280
Terminal Turning Area, RNAV	1520
Termination Point, En Route	1711, 1712
Termination Point, RNAV	1510
Terminology (Hell.)	1101
Terrain, Precipitous	A1-2
Threshold Crossing Height, ILS	936
Time Difference	1501
Touchdown Zone Elevation	A1-2
Touchdown Zone	A1-2
TPD/WP Limitation, RNAV	1510
Transition Level	A1-2
Transitional Surfaces, ILS	932
Transitional Surfaces, PAR (Hell.)	1163
Transitional Surfaces, PAR	932
Transitional Surface, SDF	1413
Transmission Interval, DF	820
Transmissometer Locations, RVR	334
Turning Areas, En Route	1713, 1714
Turning Areas, RNAV	1502
Turning Departures	1203
Turning Missed Approach Area (Hell.)	1120
Turning Missed Approach Area	275
Turning Missed Approach Obstacle Clearance (Hell.)	1121
Turning Missed Approach Obstacle Clearance	276
Turning Missed Approach, ILS	943, 944
Turning Missed Approach, PAR (Hell.)	1170
Turning Missed Approach, PAR	1033, 1034
Turning Missed Approach, RNAV	1534
Turns, Early	1204, 1205
Turn Anticipation	1501
Turn, Penetration	See Penetration Turn
Turn, Procedure	See Procedure Turn

Turn, Waypoint	1501
Type of Procedure (Hell.)	1103
Types of Procedures	5
UHF/VHF DF & Height Altitude Penetration	A2-8
Units of Measurement	210
Unstandard Lighting Systems	344
Variations of Lighting Systems	344
Vectors, ASR, Diverse	1041
Vector, Diverse	A1-2
Vector, Random	A1-2
VHF Fixes	1761
VHF Obstacle Clearance Areas	1710
Visibilities, Units Used	210
Visibility Credit for Lights	340
Visibility Credit (Hell.)	1128
Visibility Minimums	330
Visibility Reduction	343
Visibility Reduction, Operational Conditions	342
Visibility Values for RVR	335
Visibility (Hell.)	1127
Visibility, Departure	1208
Visual Descent Point (VDP)	251
Visual Portion of the Final Approach Segment	251
Volume, Service	A1-2
VOR Procedures	500
VOR/DME Procedures	500
VOR/DME RNAV Systems	1500, 1501
VOR/TACAN Accuracy	285
VORTAC Procedures	523
VORTAC RNAV Systems	1500, 1501
VOR, On Airport, No FAF	400
VOR Radial Waypoints	1505
Waypoint Displacement Area	1501
Waypoint, Instrument Approach	1501, 1502, 1505
Weather Information Required	122
Width of Final Approach Secondary Area	A2-6
Width of Intermediate Secondary Area	A2-3
Width, Arc Intermediate Approach Segment	243
Width, ASR Final	1044
Width, ASR Intermediate	1042
Width, DR Initial Approach Segment	233
Width, ILS Final Approach Area	930
Width, Initial Approach Segment	232
Width, Intermediate Segment (with Procedure Turn)	244
Width, PAR Final	1020
Width, Straight Intermediate Segment	242
Width, Straight Missed Approach Area	273
Width, Turning Missed Approach	275
Word Meaning	6
Zone of No Transgression, Simultaneous ILS	990

THIS PAGE INTENTIONALLY LEFT BLANK

FAA ORDER

8260.3B

Army
Navy
Coast Guard
Air Force

TM 95-226
OPNAV Inst. 3722.16C
CG 318
AFMAN 11-226(I)

**UNITED STATES STANDARD
FOR
TERMINAL
INSTRUMENT
PROCEDURES
(TERPS)**



VOLUME 2

**NONPRECISION
APPROACH PROCEDURE (NPA)
CONSTRUCTION**

RESERVED

U. S. DEPARTMENT OF TRANSPORTATION
FEDERAL AVIATION ADMINISTRATION

FAA ORDER

8260.3B

Army
Navy
Coast Guard
Air Force

TM 95-226
OPNAV Inst. 3722.16C
CG 318
AFMAN 11-226(I)

**UNITED STATES STANDARD
FOR
TERMINAL
INSTRUMENT
PROCEDURES
(TERPS)**



Policy Memo
Dec 28 2007

VOLUME 3

**Precision Approach (PA) and
Barometric Vertical Navigation (Baro VNAV)
Approach Procedure Construction**

**U. S. DEPARTMENT OF TRANSPORTATION
FEDERAL AVIATION ADMINISTRATION**

VOLUME 3. TABLE OF CONTENTS

PRECISION APPROACH (PA) AND BAROMETRIC VERTICAL NAVIGATION (BARO VNAV) APPROACH PROCEDURE CONSTRUCTION

	Page
CHAPTER 1. GENERAL INFORMATION	
1.0 Purpose-----	1-1
1.1 Background-----	1-1
1.2 Definitions-----	1-1
1.2.1 Approach Surface Base Line (ASBL) -----	1-1
1.2.2 Barometric Altitude -----	1-2
1.2.3 Barometric Vertical Navigation (Baro-VNAV) -----	1-2
1.2.4 Decision Altitude (DA) -----	1-2
1.2.5 Departure End of Runway (DER) -----	1-2
1.2.6 Fictitious Threshold Point (FTP) -----	1-2
1.2.7 Flight Path Alignment Point (FPAP) [RNAV Only]-----	1-3
1.2.8 Flight Path Control Point (FPCP) [RNAV Only] -----	1-4
1.2.9 Geoid Height (GH) [RNAV Only] -----	1-4
1.2.10 Glidepath Angle (GPA) -----	1-4
1.2.11 Ground Point of Intercept (GPI) -----	1-4
1.2.12 Height Above Ellipsoid (HAE) [RNAV Only]-----	1-5
1.2.13 Height Above Touchdown (HAT) -----	1-5
1.2.14 Inner-Approach Obstacle Free Zone (OFZ)-----	1-5
1.2.15 Inner-Transitional OFZ -----	1-5
1.2.16 Landing Threshold Point (LTP)-----	1-5
1.2.17 Lateral Navigation (LNAV) [RNAV only]-----	1-5
1.2.18 Microwave Landing System/Mobile Microwave Landing System ((MLS/MMLS) [DOD Only] -----	1-6
1.2.19 Object Free Area (OFA)-----	1-6
1.2.20 Obstacle Clearance Surface (OCS)-----	1-6
1.2.21 Positive Vertical/Horizontal Guidance -----	1-6
1.2.22 Precision Approach (PA)-----	1-6
1.2.23 Precision Approach Radar (PAR)-----	1-6
1.2.24 Precision Final Approach Fix (PFAF) -----	1-7
1.2.25 Pseudo Ground Point of Intercept (PGPI) -----	1-7
1.2.26 Radio Altimeter Height (RA)-----	1-7
1.2.27 Required Navigation Performance (RNP) -----	1-7
1.2.28 Runway Threshold (RWT) -----	1-7
1.2.29 Three-Dimensional (3D) Point/Waypoint. [RNAV Only] -----	1-8
1.2.30 Touchdown Zone Elevation (TDZE)-----	1-8
1.2.31 Two-Dimensional (2D) Point/Waypoint [RNAV Only] -----	1-8
1.2.32 Wide Area Augmentation System (WAAS) [RNAV Only] -----	1-8
CHAPTER 2. GENERAL CRITERIA	
2.0 Policy Directives-----	2-1
2.0.1 8260.3-----	2-1

VOLUME 3. TABLE OF CONTENTS (Continued)

	Page
2.0.2	8260.19-----2-1
2.0.3	8260.38-----2-1
2.0.4	8260.44-----2-1
2.0.5	8260.45-----2-1
2.0.6	7130.3-----2-1
2.1	Data Resolution -----2-1
2.2	Procedure Identification -----2-1
2.2.1	RNAV -----2-1
2.2.2	Non-RNAV -----2-1
2.3	En Route, Initial, and Intermediate Segments -----2-1
2.3.1	Minimum Intermediate Segment Length -----2-2
2.3.2	Determining FAC Intercept Angle where DME Source is not Collocated with FAC Facility -----2-3
2.4	RNP Values -----2-4
2.5	Maximum Authorized GPA's -----2-4
2.5.1	RNAV Glidepath Angles-----2-5
2.5.2	VGSI Angles-----2-5
2.6	Glide Slope Threshold Crossing Height Requirements -----2-7
2.6.1	Category I Threshold Crossing Height (TCH) Requirements -----2-7
2.6.2	Category II and III TCH Requirements -----2-7
2.6.3	Required TCH Values -----2-8
2.7	Ground Point of Intercept (GPI) -----2-9
2.8	Determining FPAP Coordinates [RNAV Only]-----2-9
2.9	Determining PFAF/FAF Coordinates -----2-10
2.9.1	Distance Measuring Equipment (DME) -----2-11
2.10	Common Fixes (RNAV only) -----2-11
2.11	Clear Areas and Obstacle Free Zones (OFZ) -----2-11
2.12	Glidepath Qualification Surface (GQS)-----2-11
2.12.1	Area -----2-12
2.13	ILS/MLS Critical Areas -----2-13
2.14	ILS Antenna Mast Height Limitations for Obstacle Clearance-----2-14
 CHAPTER 3. PRECISION FINAL AND MISSED APPROACH SEGMENTS	
3.0	Final Segment -----3-1
3.1	Alignment -----3-2
3.2	OCS Slope (S)-----3-2
3.2.1	Origin-----3-2
3.2.2	Revising GPA for OCS Penetrations-----3-3
3.3	Precision Object Free Area (POFA)-----3-3
3.4	“W” OCS-----3-4
3.4.1	Width -----3-4
3.4.2	Height -----3-5
3.4.3	“W” OCS Penetrations -----3-5
3.5	“X” OCS -----3-5
3.5.1	Width -----3-5

VOLUME 3. TABLE OF CONTENTS (Continued)

	Page
3.5.2	Height -----3-5
3.5.3	“X” OCS Penetrations-----3-6
3.6	“Y” OCS -----3-6
3.6.1	Width -----3-6
3.6.2	Height -----3-7
3.6.3	“Y” OCS Penetrations-----3-7
3.7	Decision Altitude (DA) and Height above Touchdown (HAT)-----3-7
3.8	Adjustment of DA for Final Approach OCS Penetrations -----3-7
3.8.1	GPI Distance -----3-8
3.8.2	Calculate the Adjusted DA and HAT -----3-8
3.8.3	Calculate the Revised Minimum Hat/Maximum ROC-----3-8
3.8.4	Compare HAT and Minimum HAT-----3-8
3.8.5	Mark and Light-----3-8
3.9	Missed Approach -----3-8
3.9.1	Section 1 -----3-9
3.9.2	Missed Approach Climb Gradient (DOD Only) -----3-17
3.9.3	Missed Approach ROC Rationale -----3-17

CHAPTER 4. BAROMETRIC VERTICAL NAVIGATION (Baro VNAV)

4.0	General -----4-1
4.1	Publishing on RNAV Charts-----4-1
4.2	Ground Infrastructure -----4-1
4.3	Glidepath Qualification Surface (GQS)-----4-1
4.4	Final Approach Segment-----4-1
4.4.1	Area -----4-1
4.4.2	Alignment -----4-2
4.4.3	Length-----4-3
4.4.4	Width -----4-3
4.4.5	Obstacle Clearance Between RWT and 250' ASBL Point -----4-4
4.4.6	Inner Surface-----4-5
4.4.7	Outer Surface-----4-6
4.4.8	Height of the OCS -----4-6
4.4.9	OCS Penetrations -----4-7
4.5	Visibility Minimums -----4-8
4.6	Missed Approach Segment-----4-9
4.6.1	Area -----4-11

APPENDIX 1. RESERVED.

APPENDIX 2. SIMULTANEOUS ILS PROCEDURES (5 pages)

1.0	General ----- 1
2.0	System Components----- 1
2.1	An ILS is Specified in Chapter 2 of this Volume for Each Runway----- 1
2.2	ATC Approved Radar for Monitoring Simultaneous Operations ----- 1
3.0	Inoperative Components ----- 1

VOLUME 3. TABLE OF CONTENTS (Continued)

	Page
4.0	Feeder Routes and Initial Approach Segment----- 1
4.1	Altitude Selection ----- 1
4.1.1	Dual----- 1
4.1.2	Triple ----- 2
4.2	Localizer Intercept Point ----- 3
5.0	Intermediate Approach Segment ----- 3
6.0	Final Approach Segment----- 4
7.0	Final Approach Course (FAC) Standards----- 4
7.1	Dual Approaches----- 4
7.2	Triple Approaches ----- 4
7.3	No Transgression Zone (NTZ)----- 4
7.4	Normal Operating Zone (NOZ) ----- 4
7.4.1	The NOZ for Dual Simultaneous ILS Approaches----- 4
7.4.2	The NOZ for Triple Simultaneous ILS Approaches ----- 5
8.0	Missed Approach Segment----- 5
8.1	Dual----- 5
8.2	Triple ----- 5
APPENDIX 3.	CLOSE PARALLEL ILS/MLS APPROACHES (8 Pages)
1.0	Background----- 1
2.0	Terminology ----- 1
2.1	Automated Alert ----- 1
2.2	Breakout----- 1
2.3	Close Parallels----- 1
2.4	E-Scan Radar ----- 1
2.5	Localizer/Azimuth Offset ----- 1
2.6	Monitor Zone ----- 2
2.7	No Transgression Zone (NTZ)----- 2
2.8	Normal Operating Zone (NOZ) ----- 2
2.9	Precision Runway Monitor (PRM) ----- 2
3.0	General ----- 2
3.1	System Components----- 3
3.1.1	ILS/MLS ----- 3
3.1.2	PRM ----- 3
3.2	Procedure Charting----- 3
4.0	Feeder Routes and Initial Approach Segment----- 4
4.1	Altitude Selection ----- 4
4.2	Localizer Intercept Point ----- 4
4.3	NTZ----- 4
4.4	NOZ ----- 4
5.0	Intermediate Approach Segment ----- 6
6.0	Final Approach Segment----- 6
6.1	Close Parallel Approach Runway Separation ----- 6
6.2	PRM ----- 6
6.3	NTZ----- 6
6.4	NOZ ----- 6

VOLUME 3. TABLE OF CONTENTS (Continued)

	Page
6.5 Staggered Runway Thresholds -----	6
6.6 Localizer/Azimuth Offset -----	6
6.7 Monitor Zone -----	7
6.7.1 Monitor Zone Length -----	7
6.7.2 Monitor Zone Width -----	7
6.7.3 Monitor Zone Height -----	7
7.0 Minimums -----	7
8.0 Missed Approach Segment-----	7
8.1 NTZ-----	8
8.2 NOZ -----	8

APPENDIX 4. OBSTACLE ASSESSMENT SURFACE EVALUATION FOR SIMULTANEOUS PARALLEL PRECISION OPERATIONS (9 Pages)

1.0 Background-----	1
2.0 Definitions-----	1
2.1 Course Width (CW)-----	1
2.2 Parallel Approach Obstruction Assessment (PAOA) -----	2
2.3 Parallel Approach Obstruction Assessment Surfaces (PAOAS)-----	2
2.4 Parallel Approach Obstruction Assessment Surface Penetration -----	2
2.5 Parallel Approach Obstruction Assessment Controlling Obstruction (PAOACO)-----	2
2.6 No Transgression Zone (NTZ)-----	2
2.7 Normal Operational Zone (NOZ)-----	2
3.0 General -----	2
3.1 Parallel Runway Simultaneous ILS Approaches-----	2
3.1.1 When Lateral Radar Separation is Less Than 3 NM-----	3
3.1.2 The 2,000 Foot NTZ-----	3
4.0 PAOA Evaluation -----	4
4.1 Surface 1 -----	4
4.1.1 Length-----	5
4.1.2 Width -----	5
4.1.3 Surface 1 Height -----	6
4.2 Surface 2-----	6
4.2.1 Length-----	6
4.2.2 Width and Height-----	6
4.3 Surface 3 (Category I) -----	6
4.3.1 Length-----	6
4.3.2 Width -----	7
4.3.3 Surface Height-----	7
4.4 Surface 4 (Category II) -----	7
4.4.1 Length-----	7
4.4.2 Width -----	7
4.4.3 Surface Height-----	8
4.5 Establishing a Latitude-Longitude List-----	8
4.6 Parallel Operations Application Requirements -----	8

VOLUME 3. TABLE OF CONTENTS (Continued)

	Page
APPENDIX 5. THRESHOLD CROSSING HEIGHT (TCH), GROUND POINT OF INTERCEPT (GPI), AND RUNWAY POINT OF INTERCEPT (RPI) CALCULATION (4 Pages)	
Appendix 5 Title Page-----	1
Figure A5-1 Non-Radar Precision TC/GPI/RPI-----	3
Figure A5-2 Precision Approach Radar (PAR) (Scanning Radar)-----	4
Figure A5-3 Precision Radar TCN/GPI/RPI -----	5

CHAPTER 1. GENERAL INFORMATION

1.0 PURPOSE.

This TERPS volume contains final and initial missed approach segment construction criteria applicable to instrument approach procedures that provide positive glidepath guidance. Apply this criteria to approaches based on instrument landing system (ILS), microwave landing system (MLS), precision approach radar (PAR), transponder landing system (TLS), wide area augmentation system (WAAS), local area augmentation system (LAAS), barometric vertical navigation (Baro-VNAV), and future 3-dimensional navigational systems.

1.1 BACKGROUND.

The ILS defined the navigational aid (NAVAID) performance standard for precision vertical and lateral guidance systems. Several different NAVAID's providing positive vertical guidance have evolved since the inception of ILS. NAVAID's capable of supporting Category I landing minimums are: ILS, PAR, MLS, TLS, WAAS, and LAAS. NAVAID's capable of providing Category II/III landing minimums are: ILS, MLS, and LAAS. A NAVAID capable of supporting Category I/II/III minimums does not qualify as a precision approach (PA) system without supporting ground infrastructure. Certain airport and obstruction clearance requirements are mandatory for the system to be considered a PA system and achieve the LOWEST minimums. These requirements are contained in AC 150/5300-13, Airport Design; and Order 8260.3, Volume 3, Precision Approach (PA), Barometric Vertical Navigation (Baro VNAV) Approach Procedure Construction, and appropriate military directives. When mandatory ground infrastructure requirements are not met, these NAVAID's may provide a vertically guided stabilized final approach descent, but command higher landing minimums. Additionally, some flight management system (FMS) avionics suites are equipped with Baro-VNAV systems that provide stabilized descent guidance.

1.2 DEFINITIONS.

1.2.1 Approach Surface Base Line (ASBL).

A horizontal line tangent to the surface of the earth at the runway threshold (RWT) point, aligned with the final approach course (see figure 1-1).

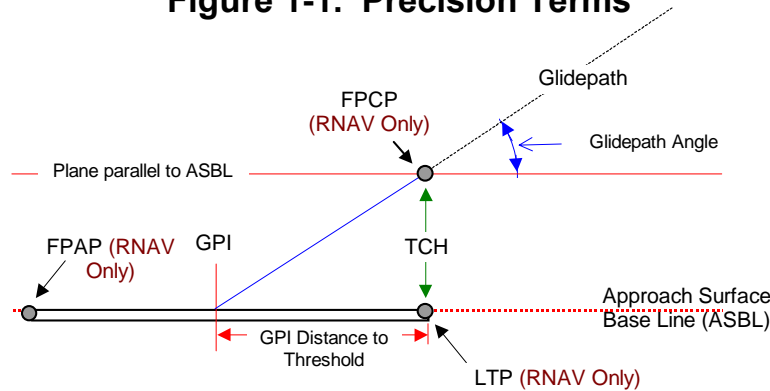
Figure 1-1. Precision Terms**1.2.2 Barometric Altitude).**

Altitude above the orthometric Geoid surface; i.e., mean sea level (MSL), based on atmospheric pressure measured by an aneroid barometer. This is the most common method of determining aircraft altitude.

1.2.3 Barometric Vertical Navigation (Baro VNAV).

RNAV and Non-RNAV. Positive vertical guidance relative to a computed glidepath that is based on the difference between published altitudes at two specified points or fixes.

1.2.4 Decision Altitude (DA).

A specified altitude in reference to mean sea level in an approach with vertical guidance at which a missed approach must be initiated if the required visual references to continue the approach have not been established.

1.2.5 Departure End of Runway (DER).

The end of the runway that is opposite the landing threshold. It is sometimes referred to as the stop end of runway.

1.2.6 Fictitious Threshold Point (FTP).

The equivalent of the landing threshold point (LTP) when the final approach course is offset from runway centerline. It is the intersection of the final course and a line perpendicular to the final course that passes through the LTP. FTP elevation is the same as the LTP (see figure 1-2).

Figure 1-2. Fictitious Threshold Point

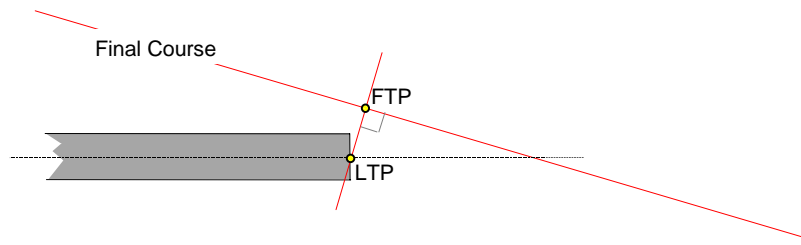

1.2.7 Flight Path Alignment Point (FPAP). [RNAV Only]

The FPAP is a 3D point defined by World Geodetic System (WGS)-84/North American Datum (NAD)-83 latitude, longitude, MSL elevation, (see figures 1-1 and 1-3). The FPAP is used in conjunction with the LTP and the geometric center of the WGS-84 ellipsoid to define the vertical plane of a PA RNAV final approach course. The approach course may be offset up to 3° by establishing the FPAP left or right of centerline along an arc centered on the LTP.

Figure 1-3. Precision Approach Path Points (Straight-In)

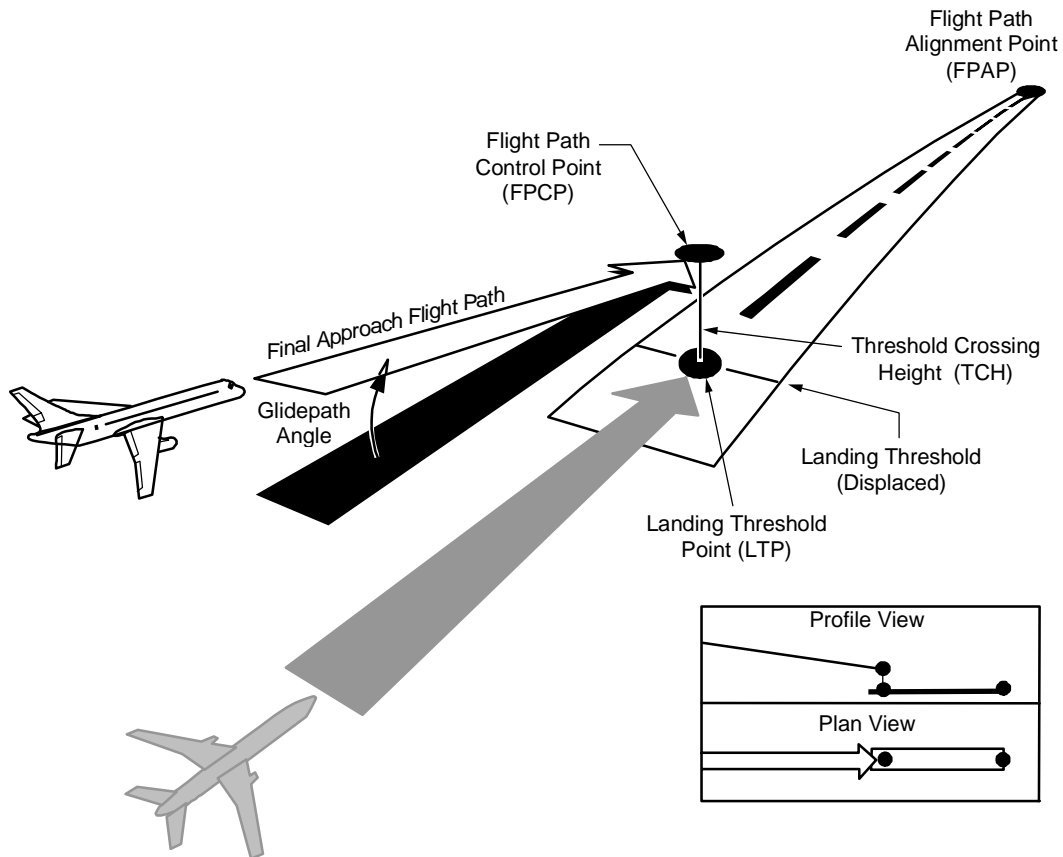

1.2.8 Flight Path Control Point (FPCP). [RNAV Only]

An imaginary point above the LTP from which the glidepath mathematically emanates. It is in a vertical plane containing the LTP and FPAP. The FPCP has the same geographic coordinates as the LTP. The elevation of the FPCP is the sum of LTP elevation and the TCH value (see figure 1-3).

1.2.9 Geoid Height (GH). [RNAV Only]

The height of the Geoid (reference surface for orthometric or MSL heights) relative to the WGS-84 ellipsoid. It is a positive value when the Geoid is above the WGS-84 ellipsoid and negative when it is below. The value is used to convert an MSL elevation to an ellipsoidal or geodetic height - the height above ellipsoid.

1.2.10 Glidepath Angle (GPA).

The angular displacement of the glidepath from a horizontal plane that passes through the LTP/FTP. This angle is published on approach charts (e.g., 3.00°, 3.20°, etc.).

1.2.11 Ground Point of Intercept (GPI).

A point in the vertical plane containing the glidepath where the vertical path intercepts the ASBL. GPI is expressed as a distance from RWT (see figure 1-4).

Figure 1-4. 3D Path & Course

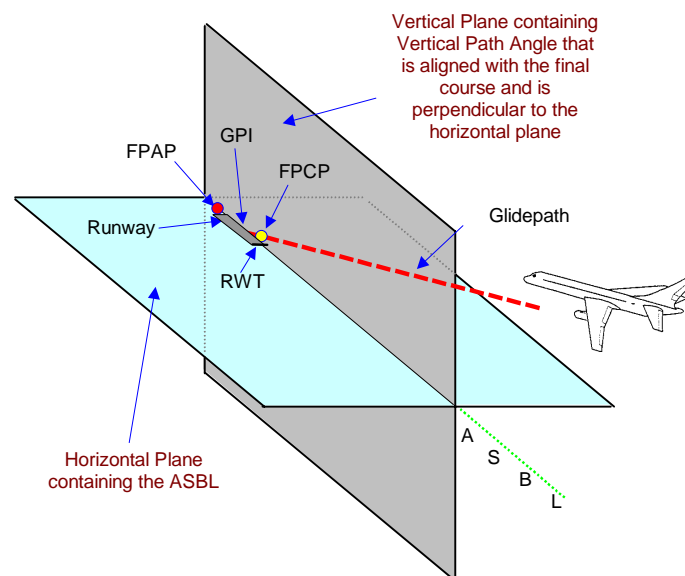

1.2.12 Height Above Ellipsoid (HAE). [RNAV Only]

A height expressed in feet above the WGS-84 ellipsoid. This value differs from a height expressed in feet above the geoid (essentially MSL) because the reference surfaces (WGS-84 Ellipsoid and the Geoid) do not coincide. To convert an MSL height to an HAE height, algebraically add the geoid height value to the MSL value. HAE elevations are not used for instrument procedure construction, but are documented for inclusion in airborne receiver databases.

EXAMPLE:	Given:	KOUN RWY 35	Runway ID
		N 35 14 31.65	Latitude
		W 97 28 22.84	Longitude
		1177.00	MSL Elevation
		-87.29 feet (-26.606 m)	Geoid Height (GH)

$$\text{HAE} = \text{MSL} + \text{GH}$$

$$\text{HAE} = 1177 + (-87.29)$$

$$\text{HAE} = 1089.71$$

1.2.13 Height Above Touchdown (HAT).

The HAT is the height of the DA above touchdown zone elevation (TDZE).

1.2.14 Inner-Approach Obstacle Free Zone (OFZ).

The airspace above a surface centered on the extended runway centerline. It applies to runways with an approach lighting system.

1.2.15 Inner-Transitional OFZ.

The airspace above the surfaces located on the outer edges of the runway OFZ and the inner-approach OFZ. It applies to runways with approach visibility minimums less than $\frac{3}{4}$ statute mile.

1.2.16 Landing Threshold Point (LTP).

The LTP is a 3D point at the intersection of the runway centerline and the runway threshold. It is defined by WGS-84/NAD-83 latitude, longitude, MSL elevation, and geoid height (see figure 1-1). It is used in conjunction with the FPAP and the geometric center of the WGS-84 ellipsoid to define the vertical plane of an RNAV final approach course. LTP elevation applies to the FTP when the final approach course is offset from runway centerline.

1.2.17 Lateral Navigation (LNAV). [RNAV Only]

Azimuth navigation without positive vertical guidance. This type of navigation is associated with nonprecision approach procedures.

1.2.18 Microwave Landing System/Mobile Microwave Landing System (MLS/MMLS). [DOD Only]

MLS/MMLS can be configured in two ways; "Split Site" where the azimuth and elevation antennas are sited the same as an ILS, or "Collocated Site" where the azimuth and elevation antennas are located together along side the runway. "Split Site" is the normal configuration for "fixed" MLS locations to meet the capability of standard MLS avionics receiver equipment. Aircraft that will use MLS/MMLS procedures configured as a "Collocated Site" must have a special MLS avionics receiver capable of computing the offset runway centerline location. These procedures will have the following caveat: "COMPUTED APPROACH: FOR USE BY AIRCRAFT CAPABLE OF COMPUTING OFFSET RUNWAY CENTERLINE ONLY." Since the MMLS has a selectable azimuth and glide slope, procedures will be published with the caveat: "FLYING OTHER THAN PUBLISHED AZIMUTH AND/OR GS ANGLE RENDERS THE PROCEDURE UNUSABLE." MMLS equipment computing capability for "collocated" configuration requires that all system components (DME/P, AZ, and EL) must be operating, thus the following caveat must be published: "ALL SYSTEM COMPONENTS MUST BE OPERATIONAL."

1.2.19 Object Free Area (OFA).

An area on the ground centered on a runway, taxiway, or taxilane centerline provided to enhance the safety of aircraft operations by having the area free of objects, except for objects that need to be located in the OFA for air navigation or aircraft ground maneuvering purposes.

1.2.20 Obstacle Clearance Surface (OCS).

An inclined obstacle evaluation surface associated with a glidepath. The separation between this surface and the glidepath angle at any given distance from GPI defines the MINIMUM required obstruction clearance at that point.

1.2.21 Positive Vertical/Horizontal Guidance.

Glidepath or course guidance based on instrumentation indicating magnitude and direction of deviation from the prescribed glidepath or course on which obstruction clearance is based.

1.2.22 Precision Approach (PA).

An approach based on a navigation system that provides positive course and vertical path guidance conforming to ILS or MLS system performance standards contained in ICAO Annex 10. To achieve lowest minimums, the ground infrastructure must meet requirements contained in AC 150/5300-13 and TERPS Volume 3.

1.2.23 Precision Approach Radar (PAR).

A ground radar system displaying an aircraft on final approach in plan and profile views in relation to glidepath and course centerlines. Air traffic controllers issue course line and glidepath information to the pilot. The pilot alters course and rate of descent in response to gain course and glidepath alignment. Military pilots may achieve 100' HAT and 1/4 mile visibility minimums with PAR.

1.2.24 Precision Final Approach Fix (PFAF). Applicable to all PA approach procedures.

A 2D point located on the final approach course at a distance from LTP/FTP where the GPA intercepts the intermediate segment altitude (glidepath intercept altitude). The PFAF marks the outer end of the PA final segment.

1.2.25 Pseudo Ground Point of Intercept (PGPI).

Phantom location abeam the GPI when the approach course is offset. PGPI elevation is the same as ASBL (see figure 1-5).

Figure 1-5. PGPI and FTP Locations

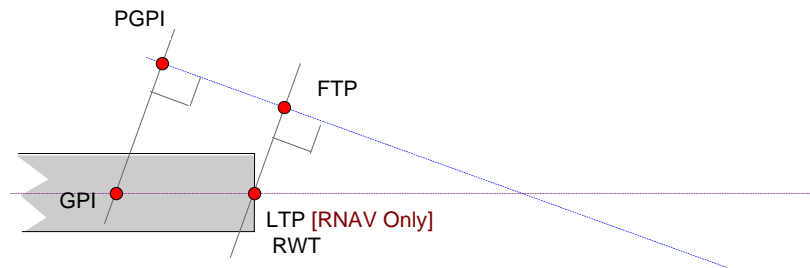

1.2.26 Radio Altimeter Height (RA).

An indication of the vertical distance between a point on the nominal glidepath at DA and the terrain directly beneath this point.

1.2.27 Required Navigation Performance (RNP).

A statement of the navigation performance accuracy necessary for operation within a defined airspace. Note that there are additional requirements, beyond accuracy, applied to a particular RNP type.

1.2.28 Runway Threshold (RWT).

The RWT marks the beginning of that part of the runway usable for landing (see figure 1-6). It extends the full width of the runway. The RWT geographic coordinates identify the point the runway centerline crosses the RWT.

Figure 1-6. Threshold**1.2.29 Three-Dimensional (3D) Point/Waypoint. [RNAV Only]**

A waypoint defined by WGS-84 latitude and longitude coordinates, MSL elevation, and GH.

1.2.30 Touchdown Zone Elevation (TDZE).

The highest elevation in the first 3,000 feet of the landing surface.

1.2.31 Two-Dimensional (2D) Point/Waypoint. [RNAV Only]

A waypoint defined by WGS-84 latitude and longitude coordinates.

1.2.32 Wide Area Augmentation System (WAAS). [RNAV Only]

A method of navigation based on the GPS. Ground correction stations transmit position corrections that enhance system accuracy and add VNAV features.

CHAPTER 2. GENERAL CRITERIA

- Policy Memo
Mar 3
2008
- 2.0 POLICY DIRECTIVES.**
- The final and missed approach criteria described in this order supersede the other publications listed below, except as noted. The following orders apply unless otherwise specified in this order:
- 2.0.1 8260.3**, United States Standard for Terminal Instrument Procedures (TERPS), Volume 1;
- 2.0.2 8260.19**, Flight Procedures and Airspace;
- 2.0.3 8260.38**, Civil Utilization of Global Positioning System (GPS);
- 2.0.4 8260.44**, Civil Utilization of Area Navigation (RNAV) Departure Procedures;
- 2.0.5 8260.45**, Terminal Arrival Area (TAA) Design Criteria; and
- 2.0.6 7130.3**, Holding Pattern Criteria.
- 2.1 DATA RESOLUTION.**
- Perform calculations using at least 0.01 unit of measure. Document latitudes and longitudes to the nearest one hundredth (0.01") arc second; elevations to the nearest hundredth (0.01') foot; courses, descent and glidepath angles to the nearest one hundredth (0.01°) degree, and distances to the nearest hundredth (0.01) unit. Where other publications require different units and/or lesser resolution, use established conversion and rounding methods.
- 2.2 PROCEDURE IDENTIFICATION.**
- 2.2.1 RNAV.**
- Title a GPS, WAAS, or Baro-VNAV approach procedure: RNAV (sensor) RWY (number). Examples: **RNAV (GPS) RWY 13, RNAV (GPS, DME/DME) Z RWY 34R**. A typical RNAV approach chart will depict minima for LPV, LNAV/VNAV, LNAV, and circling. Title LAAS procedures: GLS RWY (Runway number). Example: GLS RWY 16.
- 2.2.2 Non-RNAV.**
- Title an ILS, MLS, TLS, or LDA/glide slope procedure: XXX RWY (Runway number). Examples: **ILS RWY 16, ILS or LOC RWY 16, ILS or LOC Z RWY 5, MLS RWY 28, TLS RWY 4, LDA RWY 31L** (chart noted glide slope required).
- 2.3 EN ROUTE, INITIAL, AND INTERMEDIATE SEGMENTS.**

Policy Memo
Aug 28 2008

Apply criteria in TERPS, Volume 1 to non-RNAV approaches. Apply criteria in Order 8260.38, paragraphs 8-12, to construct the RNAV approaches except as noted. If a TAA is desired, apply Order 8260.45, paragraph 5.

***TLS NOTE:** Establish an intermediate fix (IF) defined by NAVAID's not associated with the TLS. The IF shall be on the final approach course. Establish a holding pattern at the IF (based on an inbound course to the IF) for use in the event the TLS azimuth course is not acquired.*

2.3.1 Minimum Intermediate Segment Length.

The intermediate segment blends the initial approach segment into the final approach segment. It begins at the IF and extends along the final approach course extended to the PFAF. Where a turn from the initial course to the final approach course extended is required, the initial course shall intercept at or before the IF.

2.3.1 a. Length. The MINIMUM length of the intermediate segment is 1 NM. Minimum segment length varies where a turn is required at the IF. The length is determined by the magnitude of heading change in the turn on to the final approach course extended (see figure 2-1A). The maximum angle of intersection is 90° unless a lead radial as specified in TERPS Volume 1, paragraph 232a, is provided and the length of the intermediate segment is increased as specified in TERPS Volume 1, table 3.

Figure 2-1A. Minimum Intermediate Segment Length Determined by Intercept Angle

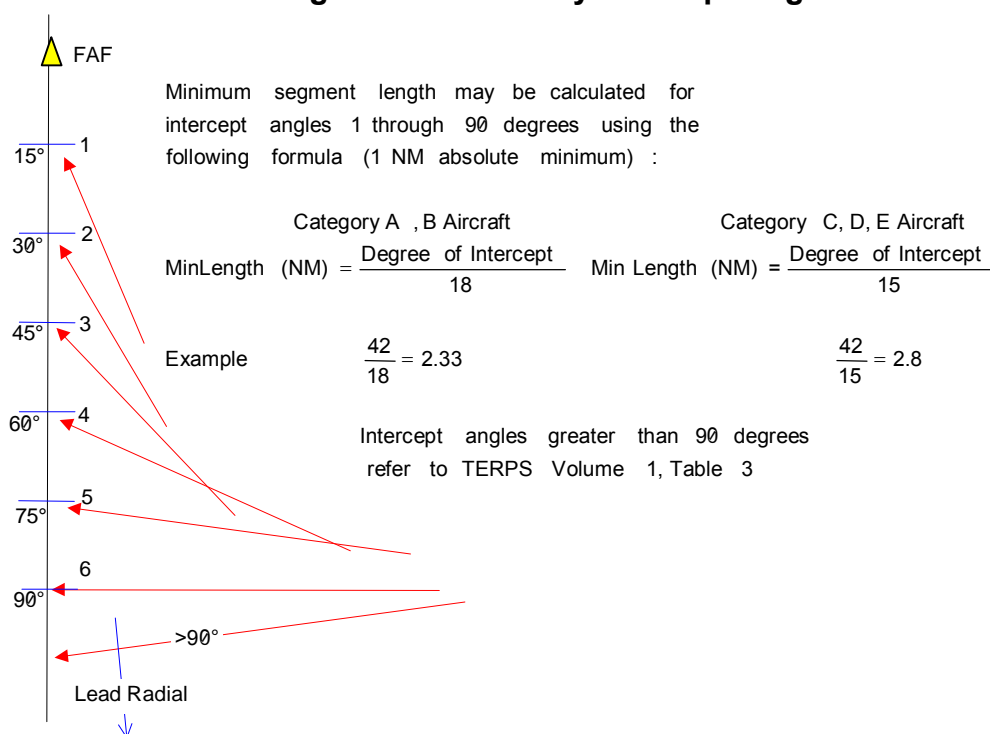

- 2.3.1 b. Width.** The intermediate trapezoid begins at the width of the initial segment at the latest point the IF can be received, to the width of the final segment at the plotted position of the PFAF (see figure 2-1B).

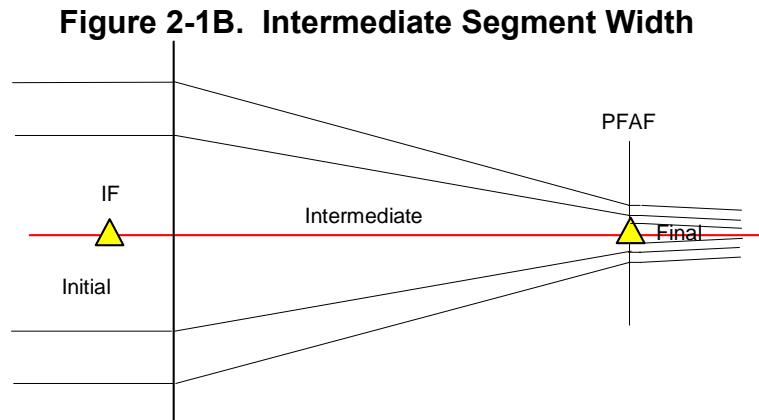

2.3.2 Determining FAC Intercept Angle Where DME Source is not Collocated with FAC Facility.

Determine the intercept initial/intermediate segment intercept angle on approach procedures utilizing ARC initial segments using the following formulas.

- 2.3.2 a. DME source on the same side of course as the aircraft** (see figure 2-2).

$$90 - |A - B| = \text{Intercept Angle} \quad \text{Example: } 90 - |270 - 285| = 75^\circ$$

Figure 2-2. Aircraft on the Same Side of Localizer as DME Sources

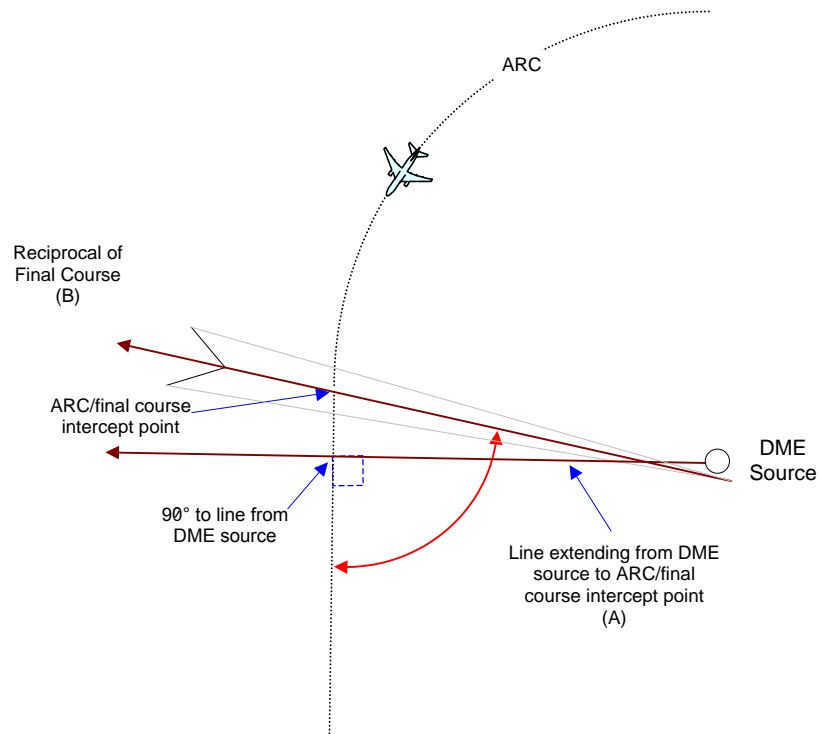

2.3.2 b. DME source on opposite side of course as the aircraft (see figure 2-3).

$$90 + |A - B| = \text{Intercept Angle} \quad \text{Example: } 90 + |270 - 285| = 105^\circ$$

Figure 2-3. Aircraft on Opposite Side of Localizer as DME Sources

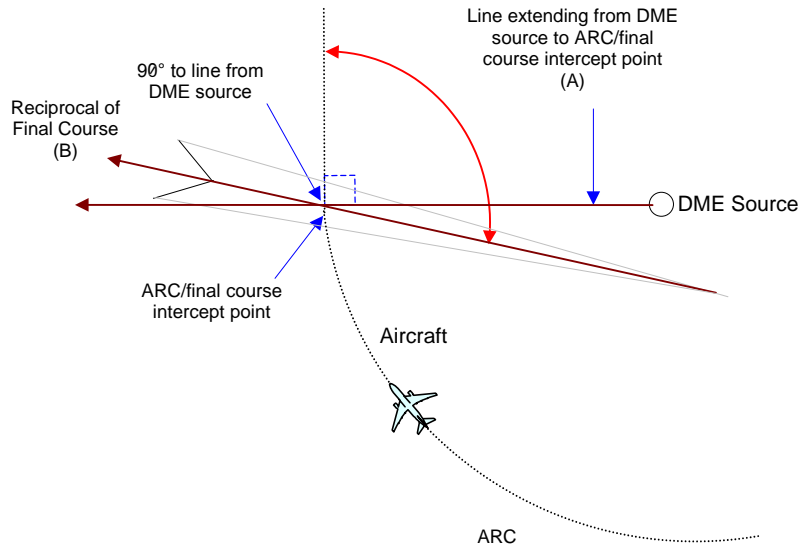

2.4 RNP VALUES.

Procedures designed under this order may be flown by aircraft with navigation systems certified to RNP values. Each segment of an RNAV procedure has a specific RNP value. Table 2-1 lists RNP values (95% accuracy) by segment type.

Table 2-1. Segment RNP Values

Segment	Lateral (NM) RNAV
En Route	2.0
Initial	1.0
Intermediate	0.5
Final	0.30
LNAV	0.30
Missed Approach	1.0

2.5 MAXIMUM AUTHORIZED GPA'S.

Tables 2-2A, 2-2B, and 2-2C list the MAXIMUM allowable GPA's and MINIMUM visibility by aircraft category, and MAXIMUM TCH values for allowing credit for approach lighting systems (USAF NA). Use Volume 1, Chapter 3 for computing landing minimums. Design all approach procedures to the same runway with the same glidepath angle and TCH. Angles above 3.0° require approval of FAA Flight Standards Service or the appropriate military authority.

Table 2-2A. Maximum GPA's

Policy
Memo
Dec 6
2005

Category	GPA
A (80 knots or less)	6.4
A (81-90 knots)	5.7
B	4.2
C	3.6
D&E	3.1

2.5.1 RNAV Glidepath Angles.

If a non-RNAV PA system (ILS, MLS, TLS, or PAR) serves the same runway as an RNAV PA system, the RNAV glidepath angle and TCH should match the non-RNAV system.

2.5.2 VGSI Angles.

A VGSI is recommended for all runways to which an instrument approach is published. Where installed, the VGSI angle and TCH should match the glidepath angle of vertically guided approach procedures to the runway.

Table 2-2B. Standard PA Landing Minimums

GLIDEPATH ANGLE (WITH APPROACH LIGHT CONFIGURATION)		MINIMUM HAT*	AIRCRAFT CATEGORY			
			A	B	C	D & E
			MINIMUM VISIBILITY			
3.00° — 3.10°	★	200	¾ 4000			
	#	200	½ 2400			
	\$	200	1800			
3.11° — 3.30°	★	200	¾ 4000	NA		
	★	250	¾ 4000	1 5000	NA	
	#	200	½ 2400	NA		
	#	250	½ 2400	¾ 4000	NA	
	\$	200	1800		NA	
	\$	250	1800		½ 2400	NA
3.31° — 3.60°	★	200	¾ 4000	NA		
	★	270	¾ 4000	1 5000	NA	
	#	200	½ 2400	NA		
	#	270	½ 2400	¾ 4000	NA	
	\$	200	2000		NA	
	\$	270	2000		½ 2600	NA
3.61° — 3.80°	★	200	¾ 4000	NA		
	#	200	½ 2400	NA		
3.81° — 4.20°	★	200	¾ 4000	NA		
	★	250	¾ 4000	1 5000	NA	
	#	200	½ 2400	NA		
	#	250	½ 2400	¾ 4000	NA	
4.21° — 5.00°	★	250	¾ 4000	NA		
	#	250	½ 2400	NA		
5.01° — 5.70°	★	300	1 5000	NA		
	#	300	¾ 4000	NA		
5.71° — 6.40° AIRSPEED NTE 80 KNOTS	★	350	1 ¼	NA		
	#	350	1 5000	NA		

* The HAT shall not be less than 200 feet for civil operations, or 100 feet for military operations.

★= No Lights \$ = # Plus TDZ/CL Lights # = MALSR, SSALR, ALSF NA = Not authorized

NOTE: For a HAT higher than the minimum, the visibility (prior to applying credit for lights) shall equal the distance from DA/MAP to RWT, or

- (a) ¾ mile up to 5.00°, or
- (b) 1 mile 5.01° through 5.70°, or
- (c) 1 ¼ miles 5.71° through 6.40°, whichever is the greater.

2.6 GLIDE SLOPE THRESHOLD CROSSING HEIGHT REQUIREMENTS.

2.6.1 Category I Threshold Crossing Height (TCH) Requirements.

2.6.1 **a. Standard.** The glide slope should be located considering final approach obstructions and achieving TCH values associated with the greatest table 2-3 wheel height group applicable to aircraft normally expected to use the runway. The TCH should provide a 30-foot wheel crossing height (WCH).

2.6.1 **b. Deviations from Standard.** The TCH shall provide a WCH of no less than 20 feet or greater than 50 feet for the appropriate wheel height group. These limits shall not be exceeded unless formally approved by a Flight Standards waiver as outlined in Order 8260.19C or by the appropriate military authority.

NOTE: 60 feet is the maximum TCH.

2.6.1 **c. Displaced Threshold Considerations.** The TCH over a displaced threshold can result in a WCH value of 10 feet if the TCH over the beginning of the full strength runway pavement suitable for landing meets table 2-3 TCH requirements.

2.6.2 Category II and III TCH Requirements.

2.6.2 **a. Standard.** The commissioned TCH shall be between 50 and 60 feet with the optimum being 55 feet.

2.6.2 **b. Deviations from the Standard.** Any deviation must be formally approved by a Flight Standards waiver as outlined in Order 8260.19 or by the appropriate military authority.

2.6.2 **c. Temporary Exemption Clause.** Paragraph 4.0 may be applied to a published PA system where the TCH is within the allowable limits in table 2-3. If the new flight inspection derived TCH is within 3 feet of the published TCH but not within the limits of table 2-3, operations may continue without waiver action for up to 365 days from the date the order is applied.

2.6.2 **c. (1) If aircraft in height group 4** have not been excluded from conducting Category II or III operations on that runway, a TCH lower than 50 feet is not permitted unless the achieved ILS reference datum height (ARDH) has averaged 50 feet or higher.

2.6.2 **c. (2) After 365 days,** a flight procedures waiver must have been approved, the situation corrected, or Category II and III operations canceled.

2.6.2 **c. (3) Flight Standards Service** or the appropriate military authority can authorize further deviation or immediately rescind this temporary exemption.

**Table 2-2C. Threshold Crossing Height Upper Limits
for Allowing Visibility Credit for Lights**

HAT (Feet)	GLIDEPATH ANGLE (Degrees)	TCH UPPER LIMIT (Feet)	HAT (Feet)	GLIDEPATH ANGLE (Degrees)	TCH UPPER LIMIT (Feet)	
200	3.00 - 3.20	75	300	3.00 - 4.90	75	
	3.21 - 3.30	70		4.91 - 5.00	71	
	3.31 - 3.40	66		5.01 - 5.10	66	
	3.41 - 3.50	63		5.11 - 5.20	61	
	3.51 - 3.60	59		5.21 - 5.30	56	
	3.61 - 3.70	55		5.31 - 5.40	52	
	3.71 - 3.80	50		5.41 - 5.50	48	
	3.81 - 3.90	47		5.51 - 5.60	43	
	3.91 - 4.00	43		5.61 - 5.70	39	
	4.01 - 4.10	39		350	3.00 - 5.60	75
	4.11 - 4.20	35			5.61 - 5.70	70
250	3.00 - 4.10	75	5.71 - 5.80		65	
	4.11 - 4.20	71	5.81 - 5.90		60	
	4.21 - 4.30	67	5.91 - 6.00		55	
	4.31 - 4.40	62	6.01 - 6.10		50	
	4.41 - 4.50	58	6.11 - 6.20		45	
	4.51 - 4.60	54	6.21 - 6.30		40	
	4.61 - 4.70	50	6.31 - 6.40		35	
	4.71 - 4.80	45	270		3.00 - 4.40	75
	4.81 - 4.90	41			4.41 - 4.50	73
	4.91 - 5.00	37		4.51 - 4.60	68	
	200	3.00 - 4.40		75	4.61 - 4.70	64
4.41 - 4.50		73		4.71 - 4.80	59	
4.51 - 4.60		68		4.81 - 4.90	55	
4.61 - 4.70		64		4.91 - 5.00	51	
4.71 - 4.80		59				
4.81 - 4.90		55				
4.91 - 5.00		51				

2.6.3 Required TCH Values.

Publish a note indicating VGSI not coincident with the procedure GPA when the VGSI angle is more than 0.2° from the GPA, or when the VGSI TCH is more than 3 feet from the procedure TCH.

Table 2-3. TCH Requirements

Representative Aircraft Type	Approximate Glidepath to Wheel Height	Recommended TCH ± 5 Feet	Remarks
<i><u>HEIGHT GROUP 1</u></i> General Aviation, Small Commuters, Corporate Turbojets, T-37, T-38, C-12, C-20, C-21, T-1, Fighter Jets, UC-35, T-3, T-6	10 Feet or less	40 Feet	Many runways less than 6,000 feet long with reduced widths and/or restricted weight bearing which would normally prohibit landings by larger aircraft.
<i><u>HEIGHT GROUP 2</u></i> F-28, CV-340/440/580, B-737, C-9, DC-9, C-130, T-43, B-2, S-3	15 Feet	45 Feet	Regional airport with limited air carrier service.
<i><u>HEIGHT GROUP 3</u></i> B-727/707/720/757, B-52, C-135, C-141, C-17, E-3, P-3, E-8, C-32	20 Feet	50 Feet	Primary runways not normally used by aircraft with ILS glidepath-to-wheel heights exceeding 20 feet.
<i><u>HEIGHT GROUP 4</u></i> B-747/767/777, L-1011, DC-10, A-300, B-1, KC-10, E-4, C-5, VC-25	25 Feet	55 Feet	Most primary runways at major airports.

- NOTES:
1. To determine the minimum allowable TCH, add 20 feet to the glidepath-to-wheel height.
 2. To determine the maximum allowable TCH, add 50 feet to the glidepath-to-wheel height (PA not to exceed 60 ft.).
 3. Publish a note indicating VGSI not coincident with the procedure GPA when the VGSI angle is more than 0.2° from the GPA, or when the VGSI TCH is more than 3 feet from the procedure TCH.

2.7 GROUND POINT OF INTERCEPT (GPI).

Calculate GPI distance using the following formula:

$$GPI = \frac{TCH}{\tan(GPA)}$$

2.8 DETERMINING FPAP COORDINATES. [RNAV Only]

The geographic relationship between the LTP and the FPAP determines the final approach ground track. Geodetically calculate the latitude and longitude of the FPAP using the LTP as a starting point, the desired final approach course

(OPTIMUM course is the runway bearing) as a forward azimuth value, and an appropriate distance. If an ILS or MLS serves the runway, the appropriate distance in feet is the distance from the LTP to the localizer antenna minus 1,000 feet, or the distance from the LTP to the DER, whichever is greater. Apply table 2-4 to determine the appropriate distance for runways not served by an ILS or MLS.

Table 2-4. Runways not served by an ILS or MLS

Runway Length	FPAP Distance from LTP	Splay	± Width
≤ 9,023'	9,023'	2.0°	350'
> 9,023' and ≤ 12,366'	to DER	$\text{ArcTan}\left(\frac{350}{\text{RWY length} + 1000}\right)$	350'
> 12,366 and ≤ 16,185'	to DER	1.5°	$\tan(1.5)(\text{RWY length} + 1,000)$
> 16,185' (AFS or Appropriate Military Agency Approval)	to DER or as specified by approving agency	1.5°	$\tan(1.5)(\text{RWY length} + 1,000)$

2.9 DETERMINING PFAF/FAF COORDINATES. See figure 2-4.

Figure 2-4. Determining PFAF Location

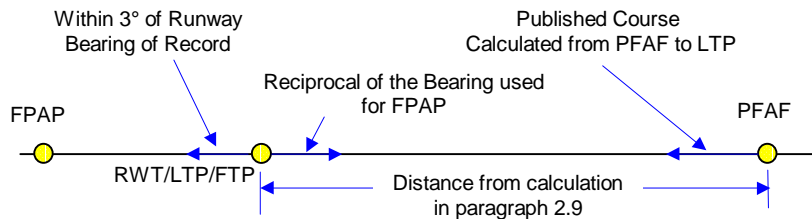

Geodetically calculate the latitude and longitude of the PFAF using the horizontal distance (D-GPI) from the LTP or FTP to the point the glidepath intercepts the intermediate segment altitude. Determine D using the following formulas: {step 2 formula includes earth curvature}

Step 1: Formula: $z = A - F$

Example: $2,100 - 562.30 = 1,537.70$

Step 2: Formula: $D = 364,609 \left(90 - \theta - \sin^{-1} \left(\frac{20,890,537 \sin(90 + \theta)}{z + 20,890,537} \right) \right)$

Example: $D = 364,609 \left(90 - 3 - \sin^{-1} \left(\frac{20,892,537 \sin(90 + 3)}{1,537.7 + 20,890,537} \right) \right)$
 $D = 28,956.03$

Where: A = PFAF Altitude in feet (example 2,100)
 F = THRe or LTP elevation in feet (example 562.30)
 θ = Glidepath angle (example 3.00 degrees)

2.9.1 Distance Measuring Equipment (DME). When installed with ILS, DME may be used in lieu of the outer marker. When a unique requirement exists, DME information derived from a separate facility, as specified in Vol. 1, chapter 2, paragraph 282, may also be used to provide ARC initial approaches, a PFAF for back course (BC) approaches, or as a substitute for the outer marker. When used as a substitute for the outer marker, the plotted position of the fix must be ≤ 16.66 NM from the DME facility and the angular divergence at the fix must not exceed 6 degrees (DoD 23 degrees).

Note: The restriction on angular divergence only applies to a DME fix used in lieu of OM for the precision approach. For localizer approaches not combined with an ILS, Vol. 1, chapter 2, paragraph 282a, applies.

2.10 COMMON FIXES [RNAV Only]. Design all procedures published on the same chart to use the same sequence of charted fixes.

2.11 GLIDEPATH QUALIFICATION SURFACE (GQS). The GQS extends from runway threshold along the runway centerline and extends to the DA point. It limits the height of obstacles between DA and runway threshold (RWT). When obstacles exceed the height of the GQS, an approach procedure with vertical guidance (ILS, PAR, MLS, TLS, LPV, LNAV/VNAV, etc.) is not authorized.

Note: Obstacles excluded by paragraph 2.11.1d may penetrate the GQS without penalty. When other obstacles penetrate the GQS, vertically guided approach operations may be authorized when mitigated (e.g., approach restricted to Height Group 1 and 2 aircraft). Contact FAA Flight Procedure Standards Branch, AFS-420, (or appropriate military equivalent) for case-by-case analysis.

2.11.1 Area.

2.11.1 a. Origin and Length. The sloping qualification surface originates at either the RWT or a specified distance from RWT (X_{OFFSET}). The surface origin height is either THRe or a specified height above THRe (V_{OFFSET}). The value of V_{OFFSET} and X_{OFFSET} are dependent on the TCH and Glidepath angle (θ).

Where the $TCH > 50$; $V_{\text{OFFSET}} = [TCH - 50]$ and $X_{\text{OFFSET}} = \text{zero } [0]$.

Where the $TCH \geq 40$ and ≤ 50 ; V_{OFFSET} and $X_{\text{OFFSET}} = \text{zero } [0]$.

Where the $TCH < 40$; $V_{\text{OFFSET}} = \text{zero } [0]$ and $X_{\text{OFFSET}} = \frac{40 - TCH}{\tan\left(\theta - \frac{\pi}{180}\right)}$

The area between the RWT and point “ X_{offset} ” is a level surface and must be clear of obstacles except obstacles permitted by the applicable airport design standard (see Vol. 3, chapter 3, paragraph 2.11.1d).

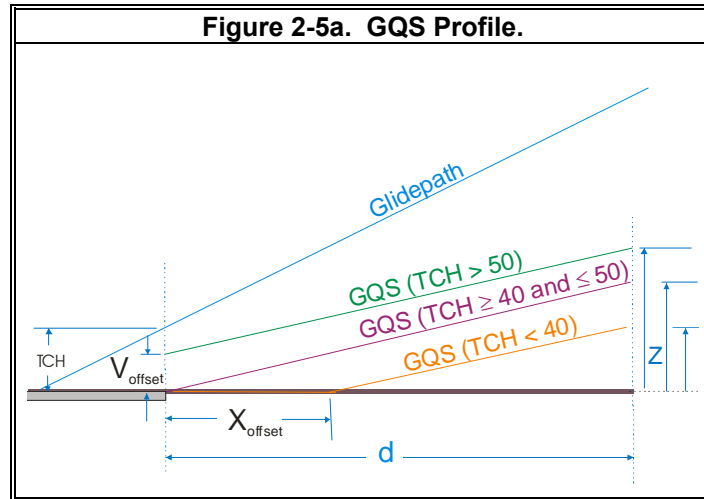

**Formula 2-1. Sloping OCS Origin
 X_{OFFSET} (TCH<40).**

$$X_{OFFSET} = \frac{4\theta - TCH}{\tan\left(\theta \cdot \frac{\pi}{180}\right)}$$

where

TCH = Threshold Crossing Height associated with procedure

\tan = tangent

θ = GPA

2.11.1

b. Width. The GQS lateral boundary is 100 ft from the runway edge at RWT. It expands uniformly to “ E ” feet (half-width) at DA (figures 2-5b and 2-5c).

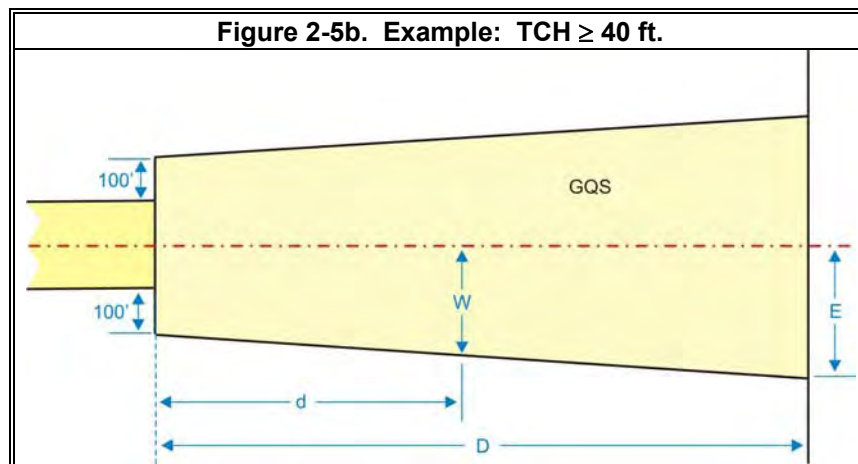

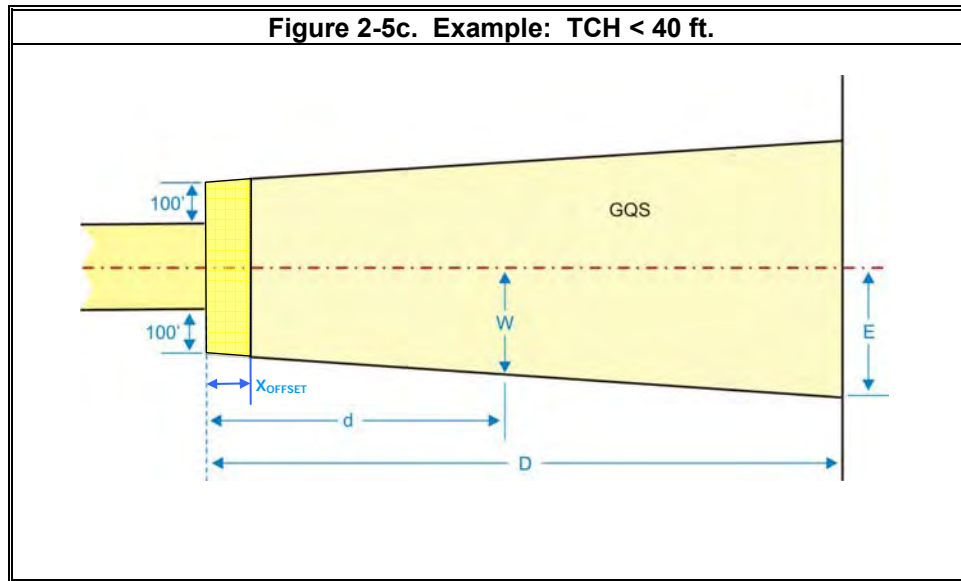

Calculate the GQS half-width “E” at the DA point measured along the runway centerline extended using formula 2-2a.

Formula 2-2a. GQS Half-Width at DA.

$$E = 0.036D + 392.8$$

where

D = RWT to DA point distance (ft) measured along RCL extended

Calculate the GQS half-width at RWT using formula 2-2b.

Formula 2-2b. GQS Half-Width at RWT.

$$k = \frac{RWY_{width}}{2} + 100$$

where

RWY_{width} = Runway width (ft)

Calculate the GQS half-width (w) at any distance “d” from RWT coordinates using formula 2-2c.

Formula 2-2c. GQS Half-Width, any distance (d).

$$w = \left(\frac{E - k}{D} d \right) + k$$

where

D = RWT coordinates to DA point dist.(ft)

d = desired distance(ft)from RWT coordinates

E = Formula 2-2a output

k = Formula 2-2b output

2.11.1

c. If the course is offset from the runway centerline more than 3 degrees, expand the GQS area on the side of the offset as follows, referring to figures 2-5d and 2-5e:

STEP 1. Construct **BC**. Locate point "B" at the intersection of the runway centerline extended and a line perpendicular to the final approach course at the DA point. Calculate the half-width (**E**) of the GQS for the distance from point "B" to the RWT coordinates. Locate point "C" at distance "E" on a line perpendicular to the final approach course. Connect points "B" and "C."

STEP 2. Construct **CD**. Locate point "D" abeam the RWT coordinates on a line perpendicular to runway centerline at a point 100 ft from the runway edge. Connect points "C" and "D."

STEP 3. Construct **DF**. Locate point "F" abeam the RWT coordinates on a line perpendicular to runway centerline at a point 100 ft from the runway edge. (opposite point "D"). Connect points "D" and "F."

STEP 4. Construct **AF**. Locate point "A" on a line perpendicular to the runway centerline extended at distance "E" from point "B". Connect points "A" and "F."

STEP 5. Construct **AB**. Connect points "A" and "B."

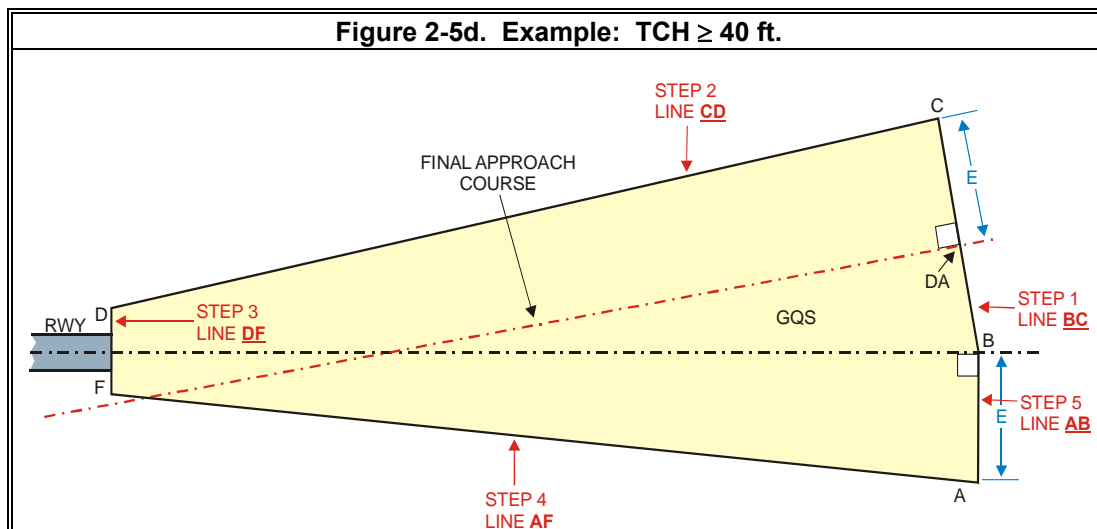

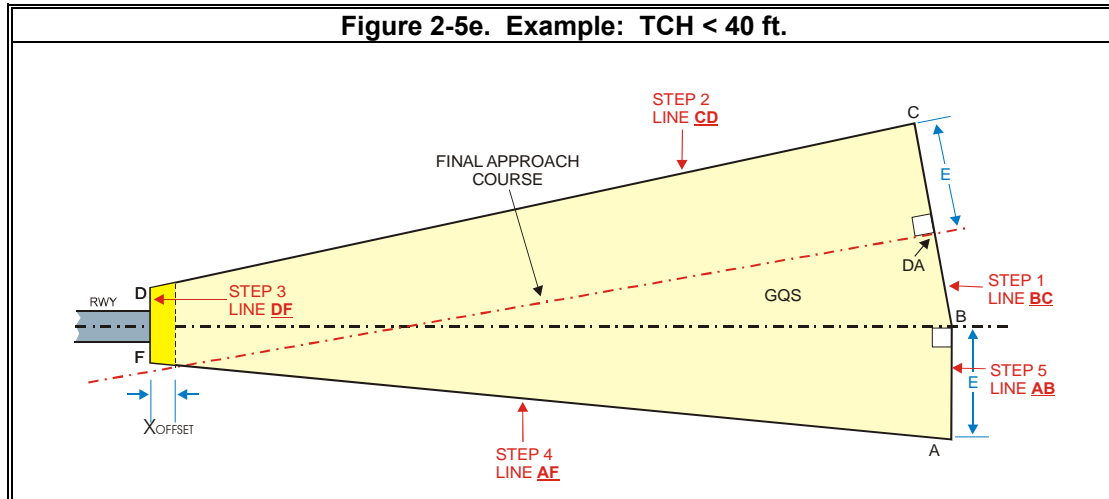

Calculate the width of the **offset side** of the GQS trapezoid using formula 2-2d (see Vol. 3, chapter 2, figure 2-5f). Calculate the width of the **non-offset side** using formula 2-2a, except "D" = distance from RWT to Point B.

Formula 2-2d. GQS Offset Side Width, any distance (d).

$$W_{\text{OFFSET}} = d \left(\frac{\cos\left(\theta \cdot \frac{\pi}{180}\right) \left[\sin\left(\theta \cdot \frac{\pi}{180}\right) (D - i) + E \right] - k}{D - \sin\left(\theta \cdot \frac{\pi}{180}\right) \left[\sin\left(\theta \cdot \frac{\pi}{180}\right) (D - i) + E \right]} \right) + k$$

where

- d = desired distance (ft) from RWT coordinates
- \cos = Cosine
- \sin = Sine
- θ = FAC offset (degrees)
- D = RWT coordinates to Point "B" distance (ft)
- i = RWT coordinates to FAC intersect. dist.(ft)
- E = Formula 2-2a output
- k = Formula 2-2b output

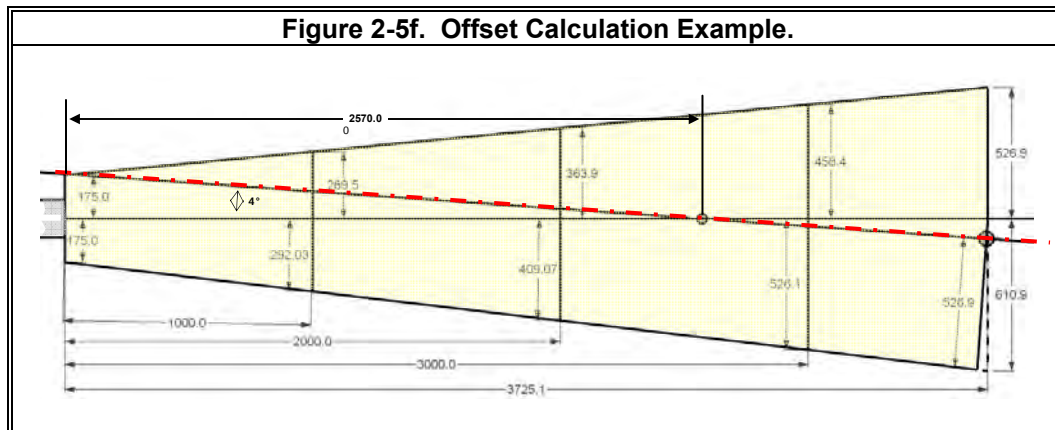
**2.11.1**

d. Clearance Surface. See Vol. 3, chapter 2, figure 2-5a. The GQS vertical characteristics reflect the glidepath characteristics of the procedure (e.g., the ILS/GLS/MLS/TLS/LPV vertical path is a straight line in space and the baro-VNAV vertical path (RNAV and RNP LNAV/VNAV) is a curved line in space). Obstacles must not penetrate the GQS [see paragraph Vol. 3, chapter 2, paragraph 2.11.1d exceptions]. Calculate the height of the sloping GQS above THRe at any distance “d” (greater than X_{OFFSET}) measured from runway threshold (RWT) coordinates along runway centerline (RCL) extended to a point abeam the obstacle using the appropriate formula:

**Formula 2-3a. GQS Elevation
ILS/GLS/MLS/TLS or LPV.**

$$Z_{ILS} = \frac{(r + F + V_{OFFSET}) \cos\left(\frac{2\theta}{3} \cdot \frac{\pi}{180}\right)}{\cos\left(\frac{d - X_{OFFSET}}{r} + \frac{2\theta}{3} \cdot \frac{\pi}{180}\right)} - r$$

where

r = mean earth radius (ft)

F = THRe or LTP elevation

V_{OFFSET} = per paragraph 2.11.1a

\cos = cosine

d = distance (ft) from RWT coordinates (greater than X_{OFFSET})

X_{OFFSET} = per paragraph 2.11.1a

θ = GPA

**Formula 2-3b. GQS Elevation
LNAV/VNAV or RNP.**

$$Z_{Baro} = e^{\frac{(d - X_{OFFSET}) \cdot \tan\left(\frac{2\theta}{3} \cdot \frac{\pi}{180}\right)}{r}} \cdot (r + LTP_{eLev} + V_{OFFSET}) - r$$

where

e = base of the natural logarithm (Napier's constant)
d = distance (ft) from RWT coordinates (greater than *X_{OFFSET}*)
X_{OFFSET} = per paragraph 2.11.1a
tan = tangent
 θ = GPA
r = mean earth radius (ft)
LTP_{eLev} = LTP elevation
V_{OFFSET} = per paragraph 2.11.1a

- 2.11.1 d. (1) For LPV (and ILS/GLS/MLS/TLS) procedures, the OCS is a flat plane (does not follow earth curvature); therefore, the height of the GQS at any point is equal to the height of surface on the runway centerline abeam it. Since the earth's surface also curves away on the lateral as well as the longitudinal axis, the MSL elevation (*OBS_{MSL}*) of an obstacle is reduced to account for earth curvature. This reduced value is termed the obstacle effective MSL elevation (*O_{EE}*). Calculate *O_{EE}* using formula 2-4 and compare to GQS height above THRe or LTP.

Formula 2-4. EC Adjusted Obstacle MSL Elevation.

$$O_{EE} = OBS_{MSL} - (r + F) \cdot \left(\frac{1}{\cos\left(\frac{OBS_Y}{r}\right)} - 1 \right)$$

where

OBS_{MSL} = obstacle MSL elevation
r = mean earth radius (ft)
F = THRe or LTP elevation
cos = cosine
OBS_Y = perpendicular dist.(ft) from runway centerline to obstacle

- 2.11.1 d. (2) Obstacles permitted by AC 150/5300-13, Airport Design (or equivalent DoD airport design standard at military airfields) are excluded from GQS evaluation as follows.
- 2.11.1 d. (2) a. Obstacles with an effective height at or below an 80:1 surface (or DoD equivalent) originating at RWT coordinates (at THRe) and extending a distance of 1,000-ft (figure 2-5g) are considered acceptable obstacles.

- 2.11.1 d. (2) b. Above-ground objects permitted by the airport design standard (e.g., AC 150/5300-13 paragraphs 305 and 308 or applicable DoD directive) are considered acceptable obstacles and are excluded from GQS evaluation.

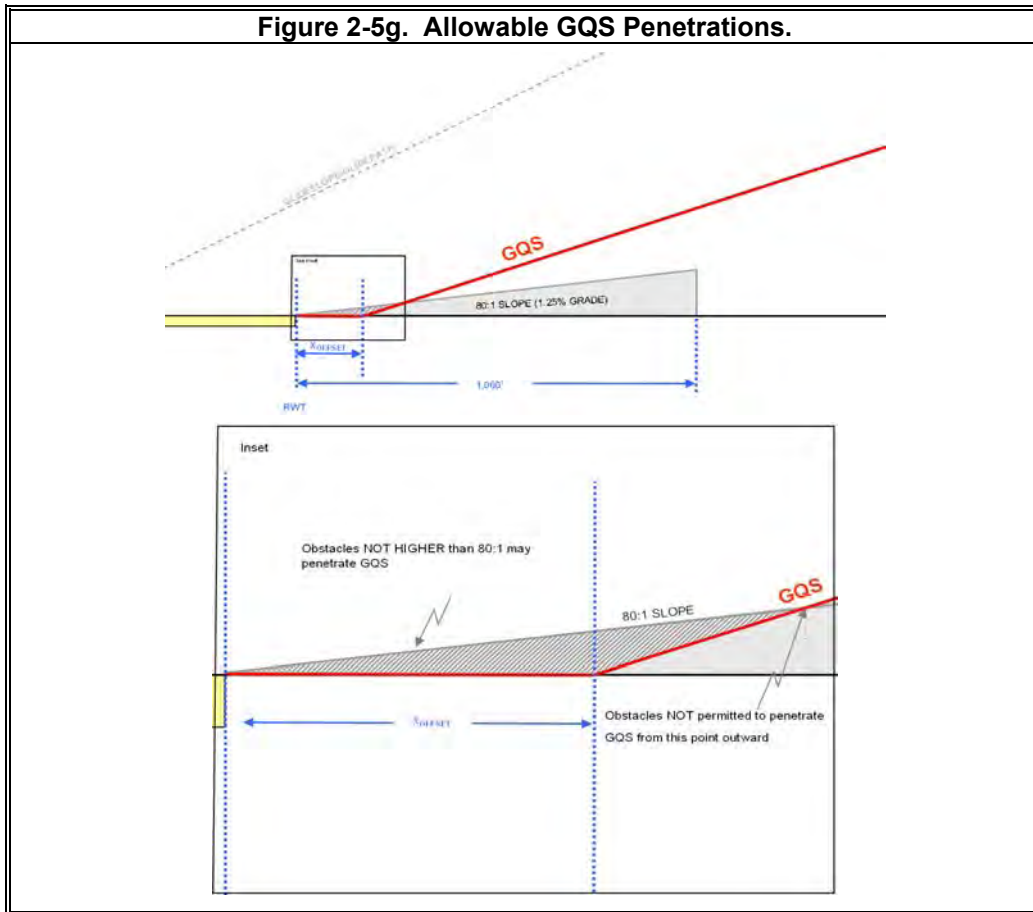

2. 12 **ILS ANTENNA MAST HEIGHT LIMITATIONS FOR OBSTACLE CLEARANCE.**
 The standard for locating the ILS antenna mast or monitor is a MINIMUM distance of 400 ft from the runway measured perpendicular to RCL. The antenna mast should not exceed 55 ft in height above the elevation of the runway centerline nearest it (see figure 2-6). At locations where it is not feasible for technical or economic reasons to meet this standard, the height and location of the antenna is restricted according to the following formula:

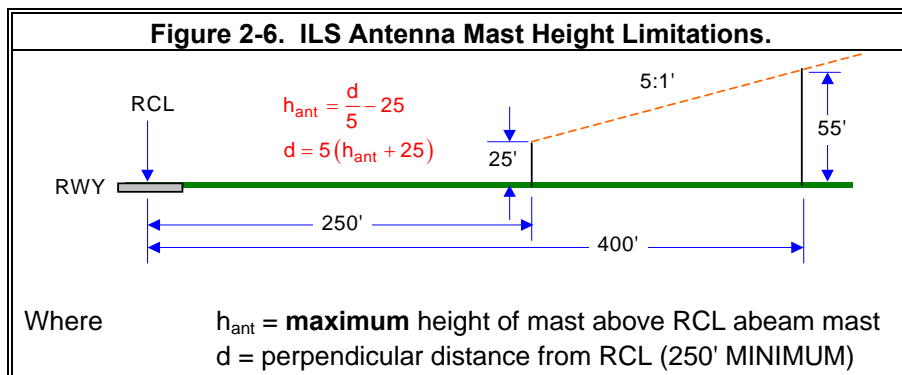

Order 8260.3B, Volume 3, Chapter 2
Formulas Addendum

Formula 2-1. Sloping OCS Origin
X_{OFFSET} (TCH<40).

$$X_{OFFSET} = \frac{40 - TCH}{\tan\left(\theta \cdot \frac{\pi}{180}\right)}$$

where

TCH = Threshold Crossing Height associated with procedure

tan = tangent

θ = GPA

$(40 - TCH) / \tan(\theta * \pi / 180)$

Calculator

TCH		Click here to calculate
θ		
X _{OFFSET}		

Back

Formula 2-2a. GQS Half-Width at DA.

$$E = 0.036D + 392.8$$

where

D = RWT to DA point dist (ft) measured along RCL extended

$$0.036 * D + 392.8$$

Calculator

D	<input type="text"/>	Click here to calculate
E	<input type="text"/>	
Back		

Formula 2-2b. GQS Half-Width at RWT.

$$k = \frac{RWY_{width}}{2} + 100$$

where

RWY_{width} = Runway width (ft)

$$RWY_{width} / 2 + 100$$

Calculator

RWY_{width}	<input type="text"/>	Click here to calculate
k	<input type="text"/>	
Back		

Formula 2-2c. GQS Half-Width, any distance (d).

$$w = \left(\frac{E - k}{D} d \right) + k$$

where

D = RWT coordinates to DA point dist.(ft)

d = desired distance(ft)from RWT coordinates

E = Formula 2-2a output

k = Formula 2-2b output

$$((E-k)/D*d)+k$$

Calculator

<i>E</i>	<input type="text"/>	Click here to calculate
<i>k</i>	<input type="text"/>	
<i>D</i>	<input type="text"/>	
<i>d</i>	<input type="text"/>	
<i>w</i>	<input type="text"/>	

Back

Formula 2-2d. GQS Offset Side Width, any distance (d).

$$W_{\text{OFFSET}} = d \left(\frac{\cos\left(\theta \cdot \frac{\pi}{180}\right) \left[\sin\left(\theta \cdot \frac{\pi}{180}\right) (D - i) + E \right] - k}{D - \sin\left(\theta \cdot \frac{\pi}{180}\right) \left[\sin\left(\theta \cdot \frac{\pi}{180}\right) (D - i) + E \right]} \right) + k$$

where

d = desired distance (ft) from RWT coordinates

cos = Cosine

sin = Sine

θ = FAC offset (degrees)

D = RWT coordinates to Point "B" distance (ft)

i = RWT coordinates to FAC intersect. dist.(ft)

E = Formula 2-2a output

k = Formula 2-2b output

$$d * ((\cos(\theta * \pi / 180) * (\sin(\theta * \pi / 180) * (D - i) + E) - k) / (D - \sin(\theta * \pi / 180) * (\sin(\theta * \pi / 180) * (D - i) + E))) + k$$

Calculator

<i>d</i>	<input type="text"/>	Click here to calculate
θ	<input type="text"/>	
<i>D</i>	<input type="text"/>	
<i>i</i>	<input type="text"/>	
<i>E</i>	<input type="text"/>	
<i>k</i>	<input type="text"/>	
<i>W_{OFFSET}</i>	<input type="text"/>	

Back

**Formula 2-3a. GQS Elevation
ILS/GLS/MLS/TLS or LPV.**

$$Z_{ILS} = \frac{(r + F + V_{OFFSET}) \cos\left(\frac{2\theta}{3} \cdot \frac{\pi}{180}\right)}{\cos\left(\frac{d - X_{OFFSET}}{r} + \frac{2\theta}{3} \cdot \frac{\pi}{180}\right)} - r$$

where

r = mean earth radius (ft)

F = THRe or LTP elevation

V_{OFFSET} = per paragraph 2.11.1a, otherwise θ

\cos = cosine

d = desired distance (ft) from RWT coordinates

X_{OFFSET} = per paragraph 2.11.1a, otherwise θ

θ = GPA

$$\frac{((r+F+V_{OFFSET}) * \cos(2*\theta/3*\pi/180))}{(\cos((d-X_{OFFSET})/r+2*\theta/3*\pi/180))-r}$$

Calclator

F	<input type="text"/>	Click here to calculate
V_{OFFSET}	<input type="text"/>	
d	<input type="text"/>	
θ	<input type="text"/>	
X_{OFFSET}	<input type="text"/>	
r	20890537	
Z_{ILS}	<input type="text"/>	

Back

**Formula 2-3b. GQS Elevation
LNAV/VNAV or RNP.**

$$Z_{Baro} = e^{\frac{(d - X_{OFFSET}) \cdot \tan\left(\frac{2\theta}{3} \cdot \frac{\pi}{180}\right)}{r}} \cdot (r + LTP_{elev} + V_{OFFSET}) - r$$

where

e = base of the natural logarithm (Napier's constant)

d = desired distance (ft) from RWT coordinates

X_{OFFSET} = per paragraph 2.11.1a, otherwise θ

tan = tangent

θ = GPA

r = mean earth radius (ft)

LTP_{elev} = LTP elevation

V_{OFFSET} = per paragraph 2.11.1a, otherwise θ

$$e^{((d-X_{OFFSET})*\tan(2*\theta/3*\pi/180)/r)*(r+LTP_{elev}+V_{OFFSET})-r}$$

Calculator

<i>d</i>		Click here to calculate
<i>X_{OFFSET}</i>		
θ		
<i>r</i>	20890537	
<i>LTP_{elev}</i>		
<i>V_{OFFSET}</i>		
<i>Z_{BARO}</i>		

Back

Formula 2-4. EC Adjusted Obstacle MSL Elevation.

$$O_{EE} = OBS_{MSL} - (r + F) \cdot \left(\frac{1}{\cos\left(\frac{OBS_Y}{r}\right)} - 1 \right)$$

where

OBS_{MSL} = obstacle MSL elevation

r = mean earth radius (ft)

F = THRe or LTP elevation

cos = cosine

OBS_Y = perpendicular dist.(ft)from Rwy centerline to obstacle

$$OBS_{MSL} - (r+F) * (1/\cos(OBS_Y/r) - 1)$$

Calculator

OBS_{MSL}		Click here to calculate
r	20890537	
F		
OBS_Y		
O_{EE}		

Back

THIS PAGE INTENTIONALLY LEFT BLANK

CHAPTER 3. PRECISION FINAL AND MISSED APPROACH SEGMENTS

3.0 FINAL SEGMENT.

The area originates 200 feet from LTP or FTP and ends at the PFAF (see figure 3-1). The primary area consists of the "W" and "X" OCS, and the secondary area consists of the "Y" OCS.

Figure 3-1. Precision Obstacle Clearance Areas

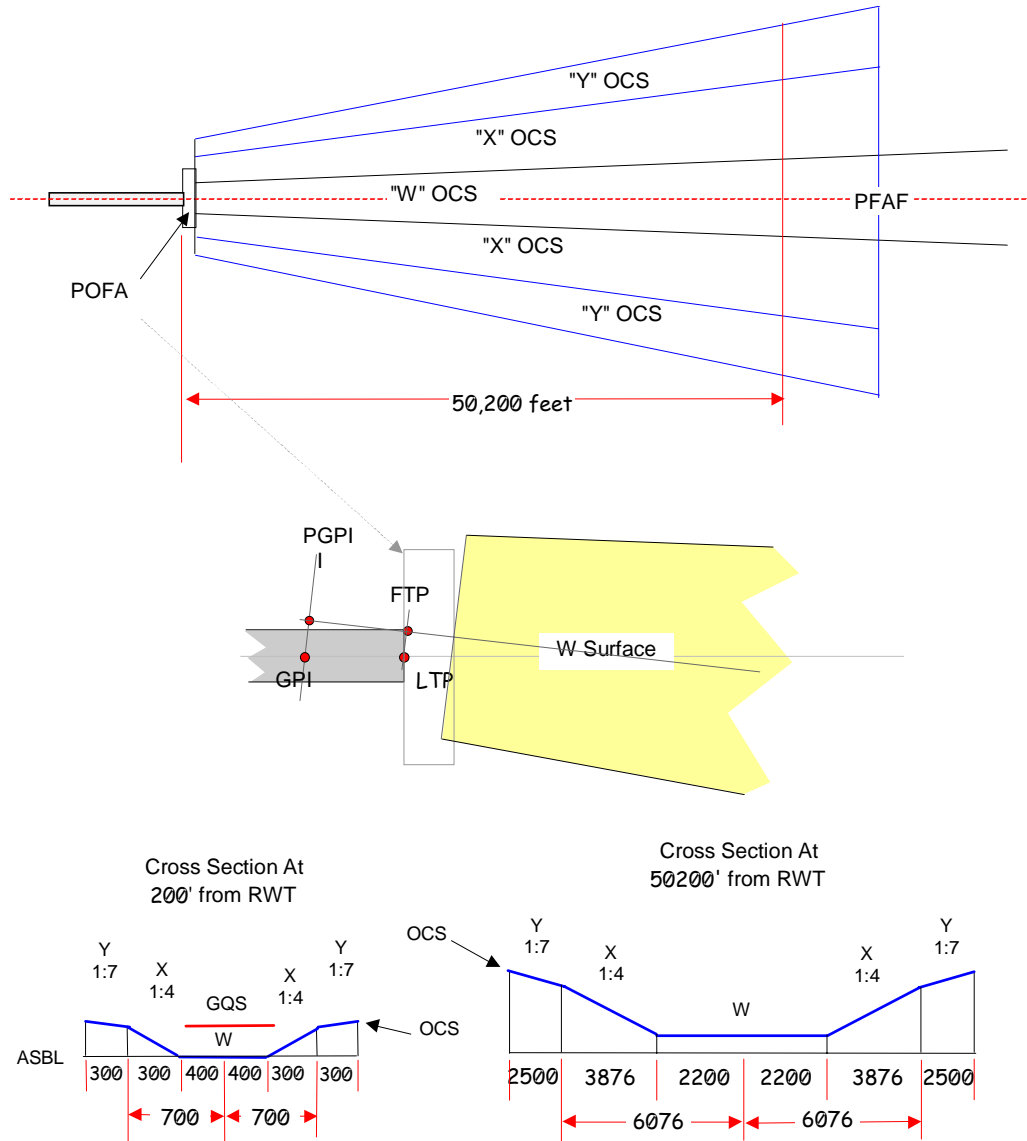

3.1 ALIGNMENT.

The final course is normally aligned with the runway centerline extended ($\pm 0.03^\circ$) through the LTP/RWT (± 5 feet). Where a unique operational requirement indicates a need for an offset course, it may be approved provided the offset does not exceed 3° . Where the course is not aligned with the RCL, the MINIMUM HAT is 250 feet, and MINIMUM RVR is 2,400 feet. Additionally, the course must intersect the runway centerline at a point 1,100 to 1,200 feet toward the LTP/RWT from the DA point (see figure 3-2).

Figure 3-2. Offset Final

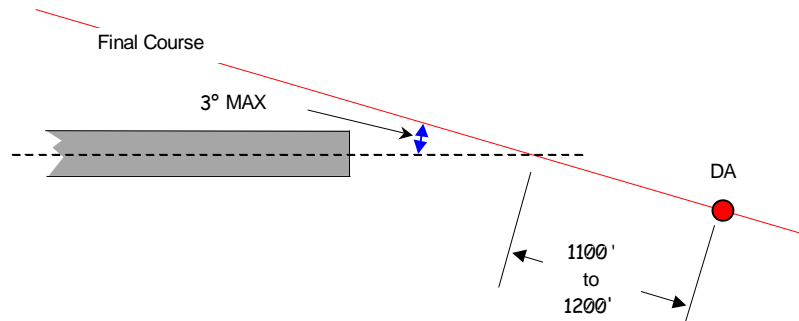

3.2 OCS SLOPE(S).

In this document, slopes are expressed as rise over run; e.g., 1:34. Determine the OCS slope associated with a specific GPA using the following formula:

$$S = \frac{102}{\text{GPA}} \quad \text{example: } \frac{102}{3} = 34$$

3.2.1 Origin.

The OCS begins at 200 feet from LTP or FTP, measured along course centerline and extends to the PFAF. The rising slope normally begins at the OCS origin. However, when the GPI to RWT distance is less than 954 feet, the slope is zero from its origin to distance 'd' from the origin. The slope associated with the glidepath begins at this point (see figure 3-3). Use the following formula to determine distance 'd':

$$d = 954 - \text{GPI} \quad \text{Example: } 954 - 801.41 = 152.59$$

$$\text{Where GPI} = 801.41$$

Figure 3-3. OCS Slope Origin When GPI < 954'

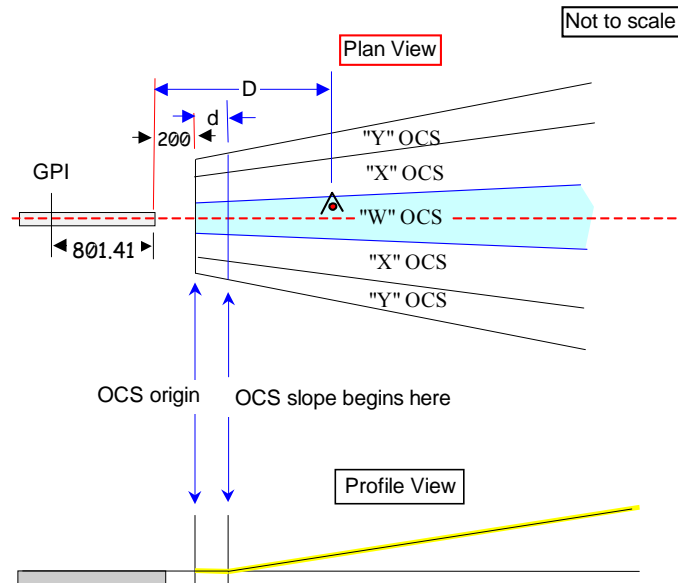

3.2.2 Revising GPA For OCS Penetrations.

Raising the glidepath angle may eliminate OCS penetrations. To determine the revised minimum glidepath angle, use the following formula:

$$\frac{102 \left[\frac{D - (200 + d)}{s} + p \right]}{D - (200 + d)} = \text{Revised Angle} \quad \text{Example: } \frac{102 \left[\frac{2200 - (200 + 0)}{34} + 2.18 \right]}{2200 - (200 + 0)} = 3.12^\circ^*$$

Where D = distance (ft) from RWT
 d = d from paragraph 3.2.1 for
 GPI < 954', 0 for GPI 954'
 or greater
 s = "W" surface slope
 p = penetration in feet

Where D = 2200
 d = 0
 s = 34
 p = 2.18

*Actual answer is 3.1118°. Always round to the next higher hundredth (0.01) degree. This prevents rounding errors in amount of penetration causing miniscule penetration values using the revised angle.

3.3 PRECISION OBJECT FREE AREA (POFA).

The POFA is an area centered on the runway centerline extended, beginning at the RWT, 200 feet long, and ± 400 feet wide. The airport sponsor is responsible for maintaining POFA obstruction requirements in AC 150/5300-13 (see figure 3-4). If the POFA is not clear, the minimum HAT/visibility is 250 feet/ 3/4 SM.

Figure 3-4. POFA

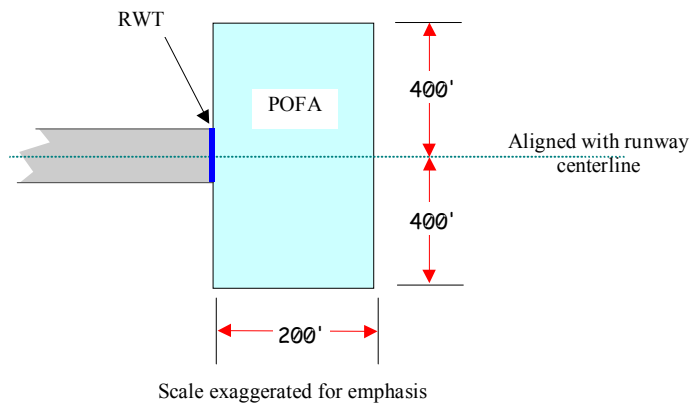

3.4 "W" OCS. See figure 3-5.

Figure 3-5. "W" OCS

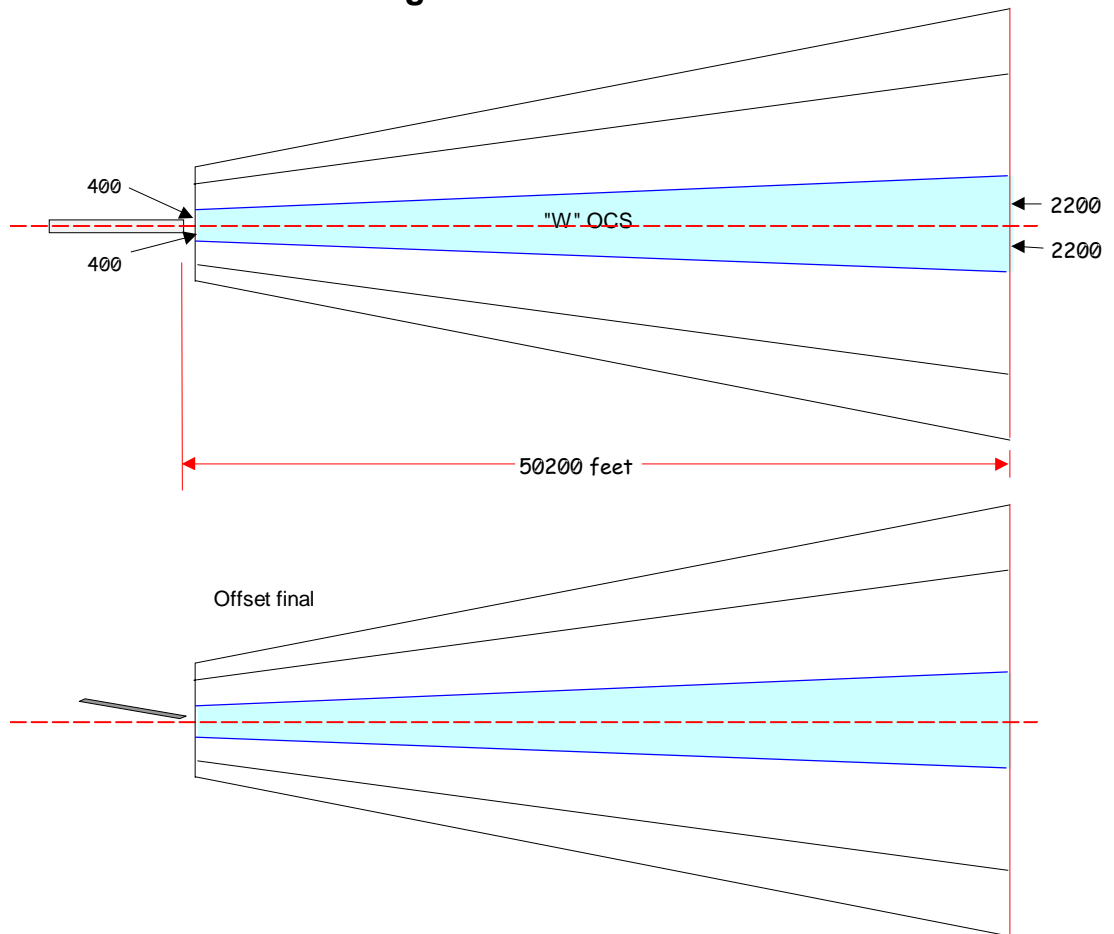

3.4.1 Width. The width is 400 feet either side of course at the beginning, and expands uniformly to 2,200 feet either side of course 50,200 feet from LTP or FTP, as defined by the formula:

$$D_W = 0.036(D - 200) + 400$$

Where D = the distance in feet from LTP or FTP.

D_W = Perpendicular distance in feet from course centerline to "W" surface outer boundary.

3.4.2 Height. The height (Z_W) of the "W" OCS above ASBL is defined by the formula:

$$Z_W = \frac{D - (200 + d)}{S}$$

Where D = the distance in feet from RWT

d = d from paragraph 3.2.1 for GPI < 954', 0 for GPI ≥ 954' or greater

S = "W" surface slope

3.4.3 "W" OCS Penetrations. Lowest minimums are achieved when the "W" surface is clear. If the surface is penetrated by an existing obstacle, adjust obstruction height, raise the GPA (see paragraph 3.2.2), or displace the RWT to eliminate the penetration. If the penetration cannot be eliminated, adjust the DA (see paragraph 3.8).

3.5 "X" OCS. See figure 3-6.

Figure 3-6. "X" OCS

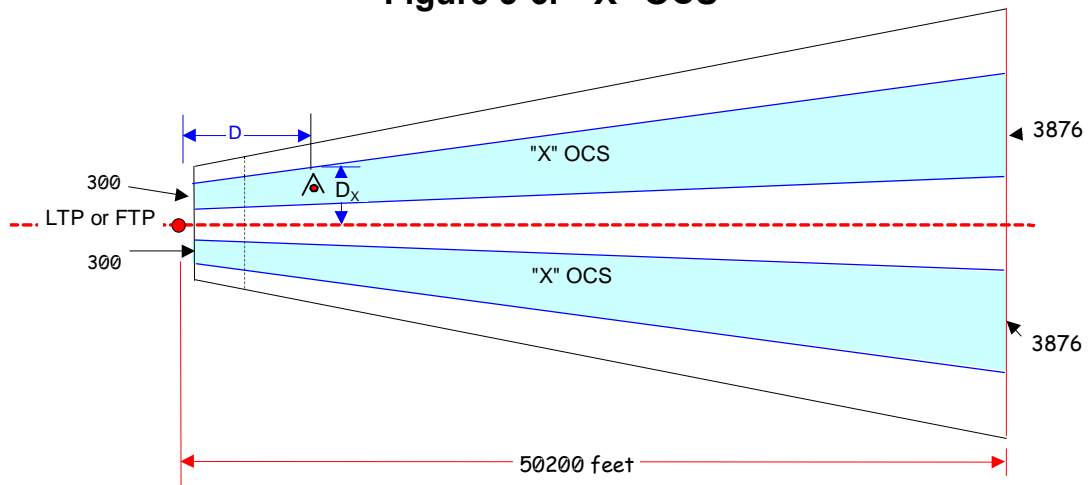

3.5.1 Width. The perpendicular distance (D_x) from the course to the outer boundary of the "X" OCS is defined by the formula:

$$D_x = 0.10752(D - 200) + 700$$

Where D = distance (ft) from LTP or FTP

3.5.2 Height. The "X" OCS begins at the height of the "W" surface at distance "D" from LTP or FTP, and rises at a slope of 1:4 in a direction perpendicular to the final approach course. Determine the height (Z_x) above ASBL for a specific location of the "X" OCS using the following formula:

$$Z_x = \frac{\text{Height of "W" Sfc}}{S} + \frac{\text{Rise of "X" Sfc}}{4}$$

$$Z_x = \frac{D - (200 + d)}{S} + \frac{D_o - D_w}{4}$$

Where D = the distance in feet from LTP or FTP,

d = d from paragraph 3.2.1 for GPI < 954', 0 for GPI 954' or greater

D_o = the perpendicular distance in feet between course centerline and a specific point in the "X" surface

D_w = the perpendicular distance between course centerline and the "W" surface boundary.

$$S = \text{Slope associated with GPA} \left[\frac{102}{\text{GPA}} \right]$$

3.5.3 "X" OCS Penetrations. Lowest minimums can be achieved when the "X" OCS is clear. To eliminate, avoid, or mitigate a penetration, take one of the following actions listed in the order of preference.

3.5.3 a. Remove or adjust the obstruction location and/or height.

3.5.3 b. Displace the RWT.

3.5.3 c. Raise the GPA (see paragraph 3.2.2) within the limits of table 2-2A.

3.5.3 d. Adjust DA (for existing obstacles only). (See paragraph 3.8).

3.6 "Y" OCS. See figure 3-7.

Figure 3-7. "Y" OCS

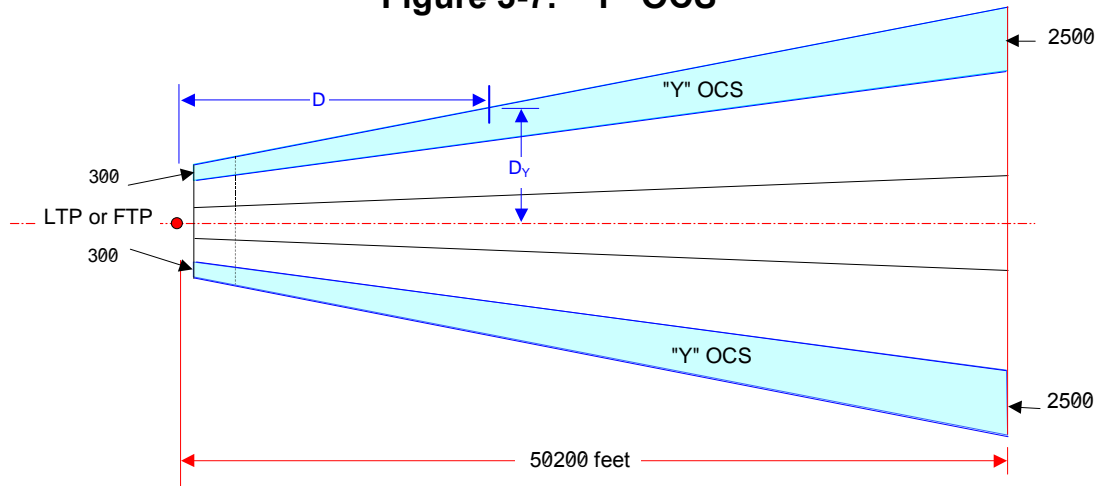

3.6.1 Width. The perpendicular distance (D_Y) from the runway centerline extended to the outer boundary of the "Y" OCS is defined by the formula:

$$D_Y = 0.15152(D - 200) + 1000$$

Where D = distance (ft) from LTP or FTP

3.6.2 Height. The "Y" OCS begins at the height of the "X" surface at distance "D" from LTP or FTP, and rises at a slope of 1:7 in a direction perpendicular to the final approach course. The height (Z_Y) of the "Y" surface above ASBL is defined by the formula:

$$D_Y = \frac{\text{Height of "W" Sfc} - (200 + d)}{S} + \frac{\text{Rise of "X" Sfc} - D_X - D_W}{4} + \frac{\text{Rise of "Y" Sfc} - D_0 - D_X}{7}$$

Where D = the distance in feet from the LTP or FTP,

d = d from paragraph 3.2.1 for GPI < 954', 0 for GPI 954' or greater

D_X = the perpendicular distance in feet between course centerline and "X" surface outer boundary,

D_0 = perpendicular distance in feet between course centerline and an obstruction in the "Y" surface.

3.6.3 "Y" OCS Penetrations. Lowest minimums can be achieved when the "Y" OCS is clear. When the OCS is penetrated, remove the obstruction or reduce its height to clear the OCS. If this is not possible, a subjective evaluation is necessary. Consider the obstruction's physical nature, the amount of penetration, obstruction location with respect to the "X" surface boundary, and density of the obstruction environment to determine if the procedure requires adjustment. (**USAF:** Adjustment mandatory if obstruction cannot be removed, height adjust, or options in paragraphs 3.6.3 b-d cannot be accomplished.) If an adjustment is required, take the appropriate actions from the following list:

- 3.6.3 a. Adjust DA** for existing obstacles (see paragraph 3.8).
- 3.6.3 b. Displace threshold.**
- 3.6.3 c. Offset final course.**
- 3.6.3 d. Raise GPA** (see paragraph 3.2.2).
- 3.6.3 e. If an adjustment is not required,** CHART the obstruction.

3.7 DECISION ALTITUDE (DA) AND HEIGHT ABOVE TOUCHDOWN (HAT).

The DA value may be derived from the HAT. The MINIMUM HAT for Category I operations is 200 feet. Calculate the DA using the formula:

$$DA = HAT + TDZE$$

3.8 ADJUSTMENT OF DA FOR FINAL APPROACH OCS PENETRATIONS. See figure 3-8.

The distance from GPI to the DA may be increased to ensure DA occurs at a height above ASBL providing sufficient obstruction clearance. This adjustment is available for existing obstacles only. Proposed obstructions shall not penetrate the OCS.

- 3.8.1 GPI Distance.** Determine the distance from LTP to the adjusted DA point using the formula:

$$D_{\text{adjusted}} = \frac{102h}{\text{GPA}} + (200 + d)$$

Where D_{adjusted} = adjusted distance (ft) from LTP to DA
 $D=d$ from paragraph 3.2.1 for $\text{GPI} < 954'$, 0 for $\text{GPI} \geq 954'$
 H = obstacle height (ft) above ASBL

*NOTE: If obstacle is in the "X" surface, subtract "X" surface rise from h .
 If obstacle is in the "Y" surface, subtract "X" and "Y" surface rise from h .*

Figure 3-8. DA Adjustment

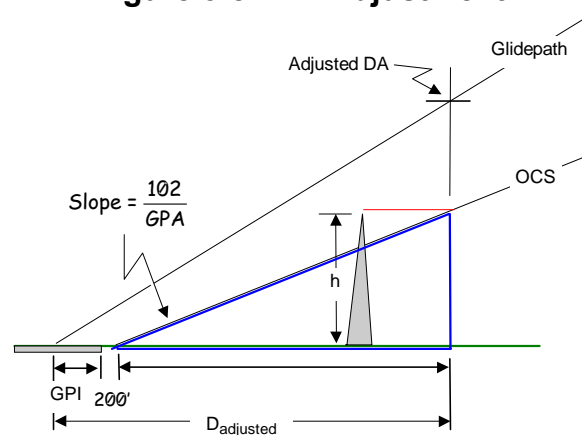

- 3.8.2 Calculate the adjusted DA and HAT:**

$$DA = \tan \left(\left[\frac{102h}{\text{GPA}} + (200 + d) \right] + \frac{\text{TCH}}{\tan(\text{GPA})} \right) + \text{LTP}_{\text{elevation}}$$

$$\text{HAT} = DA - \text{TDZE}$$

- 3.8.3 Calculate the revised minimum HAT/maximum ROC using the formula:**

$$\text{Min Hat and Max ROC} = \frac{\text{GPA}}{3} 250$$

- 3.8.4 Compare HAT and Minimum HAT.** Publish the higher of the two values.

- 3.8.5 Mark and Light.** Initiate action to mark and light obstruction(s) that would require DA adjustment when they are located between the DA and the LTP/FTP.

3.9 MISSED APPROACH.

The missed approach segment begins at DA and ends at the clearance limit. It is comprised of section 1 (initial climb) and section 2 (from end of section 1 to the clearance limit). Section 2 is constructed under criteria contained in Order 8260.44 for RNAV procedures. Section 2 beginning width is ± 0.5 NM.

The 40:1 OCS begins at the elevation of section 1b at centerline. The MA procedure is limited to two turn fixes (see figure 3-9A).

3.9.1 Section 1. Section 1 is aligned with the final approach course. It is comprised of 3 subsections, beginning at DA and extending 9860.69 feet.

Figure 3-9A. Missed Approach Sections 1a,b,c

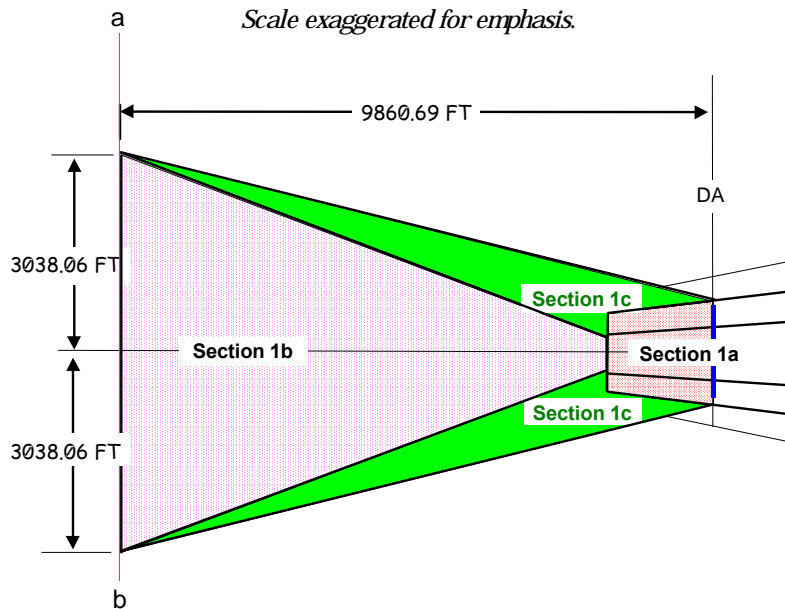

3.9.1 a. Section 1a.

Policy 3.9.1
Memo
Nov 16
2010

a. (1) Area. Section 1a begins at the DA point and overlies the final approach primary ("W" and "X" surfaces) OCS, extending 1,460 feet in the direction of the missed approach. This section is always aligned with the final approach course (see figures 3-9B and 3-9C).

3.9.1 a. (2) OCS. The height of the section 1a surface is equal to the underlying "W" or "X" surface as appropriate. If this section is penetrated, adjust DA per figure 3-9C to mediate the penetration.

Figure 3-9B . Section 1a

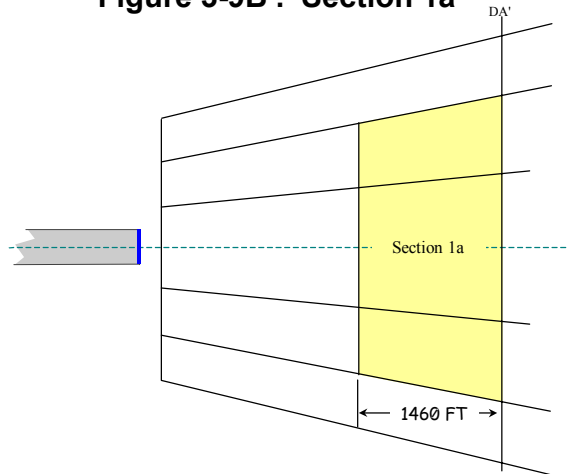
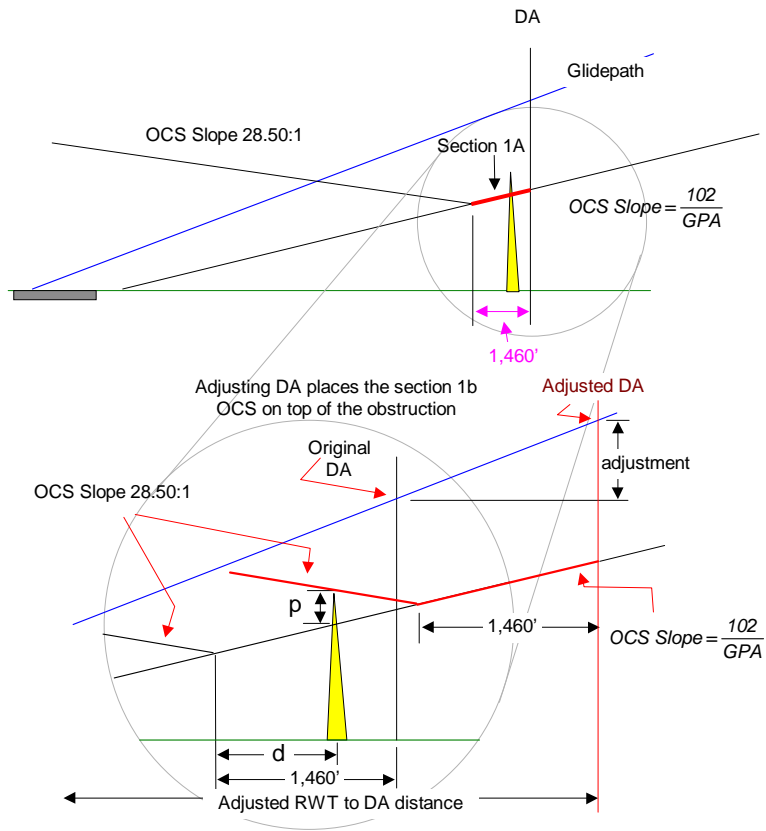

Figure 3-9C. Penetration of Section 1a OCS



$$d = x_O - (\text{RWT to DA Distance} - 1,460)$$

$$\text{adjustment} = \tan(\text{GPA}) \times \left[\left(\frac{p}{\frac{1}{28.50} + \frac{\text{GPA}}{102}} \right) + d \right]$$

adjusted DA (MSL) = original DA + adjustment

$$\text{adjusted RWT to DA Distance} = \frac{\text{Adjusted DA (MSL)} - (\text{RWT MSL Elevation} + \text{TCH})}{\tan(\text{GPA})}$$

where p = penetration (ft)
 GPA = glidepath angle
 x_O = distance from RWT to obstruction
 d = distance (ft) from obstruction to point
 where the 28.50 : 1 OCS originates

3.9.1

b. Section 1b.

3.9.1

b. (1) Area. Section 1b begins at the end of section 1a, extends to a point 9860.69 feet from DA, and splays along the extended final course to a total width of 1 NM. This section is always aligned with the final approach course (see figures 3-9A, 3-9D).

3.9.1

b. (2) OCS. Section 1b OCS is a 1:28.5 inclined plane rising in the direction of the missed approach. The height of the beginning of section 1b is equal to the height of the "W" OCS at the end of section 1a (see figure 3-9D). Evaluate obstructions using the shortest distance of the obstruction from the end of section 1a. Adjust DA per figure 3-9E to mediate penetrations in this section.

Figure 3-9D. Section 1b

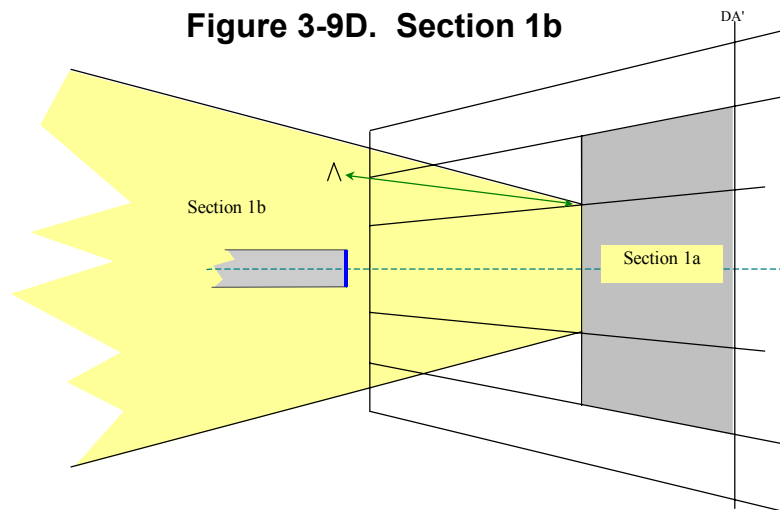
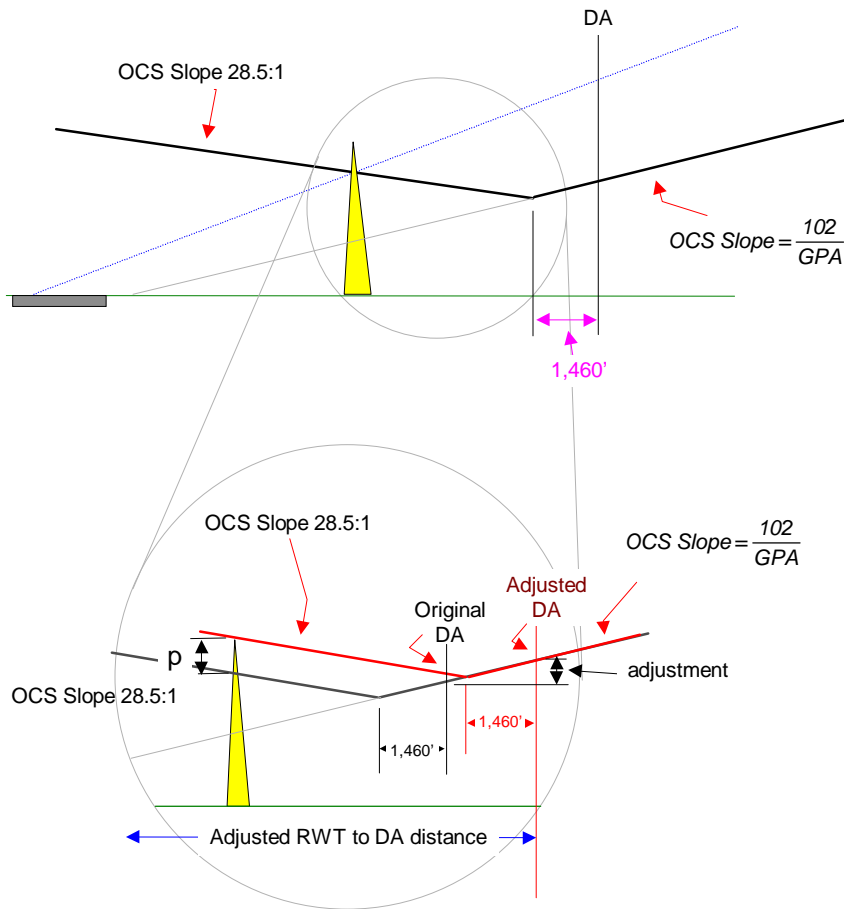

Figure 3-9E. Penetration of Section 1b OCS



$$\text{adjustment} = \tan(\text{GPA}) \times \left(\frac{p}{\frac{1}{28.5} + \frac{1}{102}} \right)$$

$$\text{adjusted DA (MSL)} = \text{original DA} + \text{adjustment}$$

$$\text{adjusted RWT to DA Distance} = \frac{\text{adjusted DA (MSL)} - (\text{RWT MSL Elevation} + \text{TCH})}{\tan(\text{GPA})}$$

where p = penetration (ft)
 GPA = glide path angle

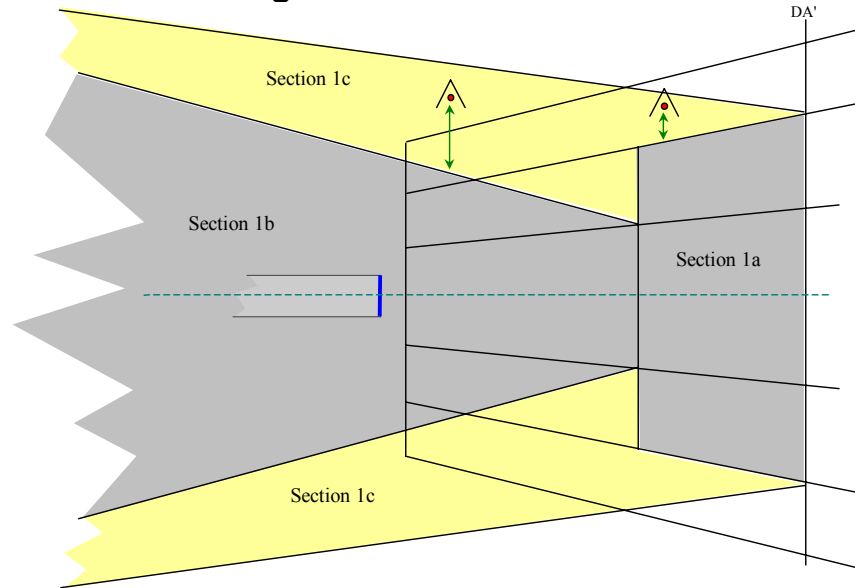
Figure 3-9F. Section 1c

- 3.9.1 c. Section 1c** (see figure 3-9F).
- 3.9.1 c. (1) Area.** These are 1:7 secondary areas that begin at the DA point. These sections splay to a point on the edge and at the end of section 1b.
- 3.9.1 c. (2) OCS.** An inclined plane starting at the DA point and sloping 1:7, perpendicular to the MA course. The inner boundaries originate at the elevation of the outer edges of the "W" surface at the beginning of section 1b. The outer boundaries originate at the elevation of the outer edges of the "X" surfaces at the DA point. These inner and outer boundaries converge at the end of section 1b (9860.69 feet from the DA point). Obstacles in section 1c, adjacent to the "X" surfaces, are evaluated with a 1:7 slope from the elevation of the outer boundaries of the "X" surfaces. Obstacles in section 1c, adjacent to section 1b, are evaluated using the 1:7 slope, beginning at the elevation at the outer edge of section 1b (see figures 3-9A and 3-9F). Reduce the obstruction height by the amount of 1:7 surface rise from the edge of section 1a or 1b (measured perpendicular to section 1 course). Then evaluate the obstruction as if it were in section 1a or 1b.
- 3.9.1 d. Section 2. [RNAV Only]** Apply Order 8260.44 criteria in this section. Instead of the departure trapezoid originating at DER altitude at the DER, it originates at the elevation of the end of section 1b OCS at centerline, with a width of ± 0.5 NM (along the ab line). It ends at the plotted position of the clearance limit. The primary and secondary widths shall be the appropriate width from the distance flown. Establish a fix on the continuation of the final approach course at least 0.5 NM from the end of section 1 (ab line). If the fix is a fly-by turning waypoint, locate the fix at least DTA+0.5 NM from the ab line (see figures 3-10A and 3-10B). Use table 3-1 airspeeds to determine turn radii from Order 8260.44, table 2. Establish the outer boundary radius of a turning procedure based on the highest category aircraft authorized to use the approach.

Table 3-1

Category	MA Altitude < 10,000' MSL	MA Altitude ≥ 10,000' MSL
A, B	200 KIAS	200 KIAS
C, D, E	250 KIAS	310 KIAS

Figure 3-10A. Turning Missed Approach with Turning Fix at the Minimum Required Distance

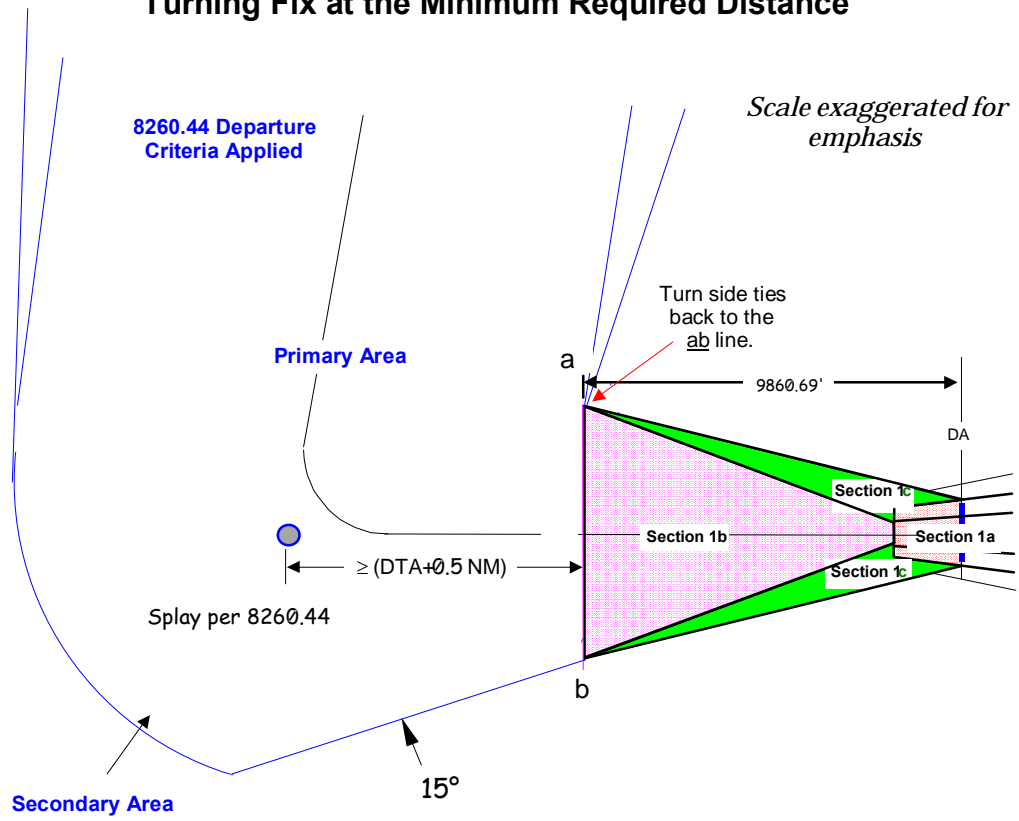
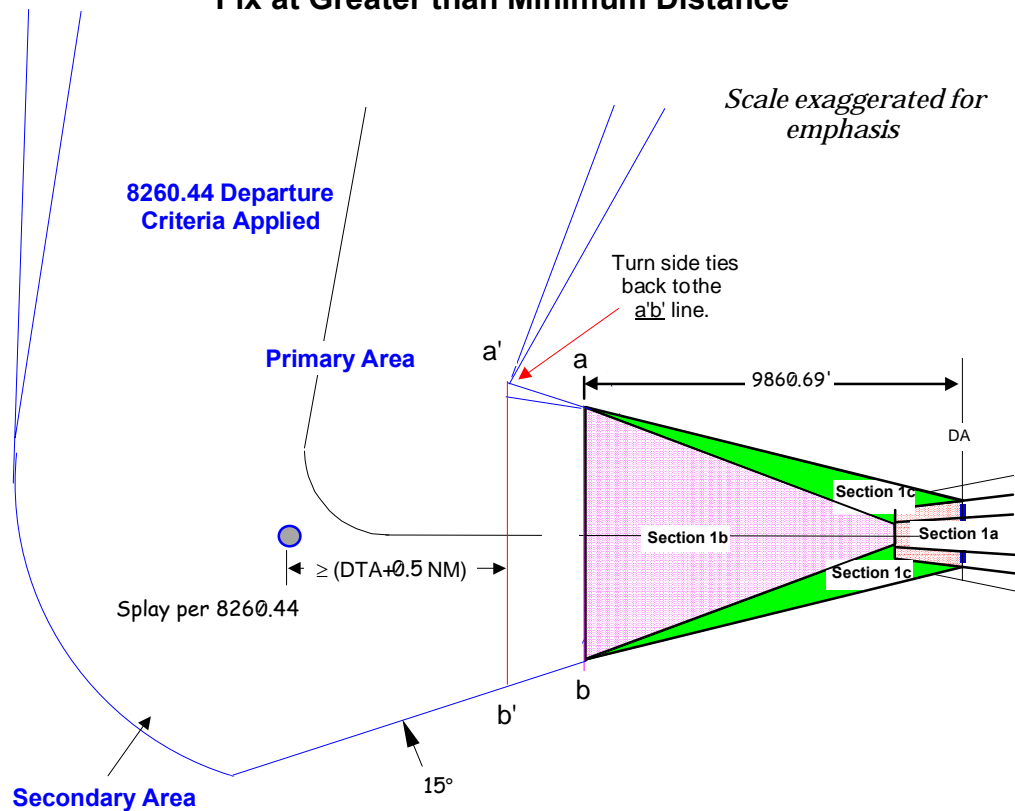
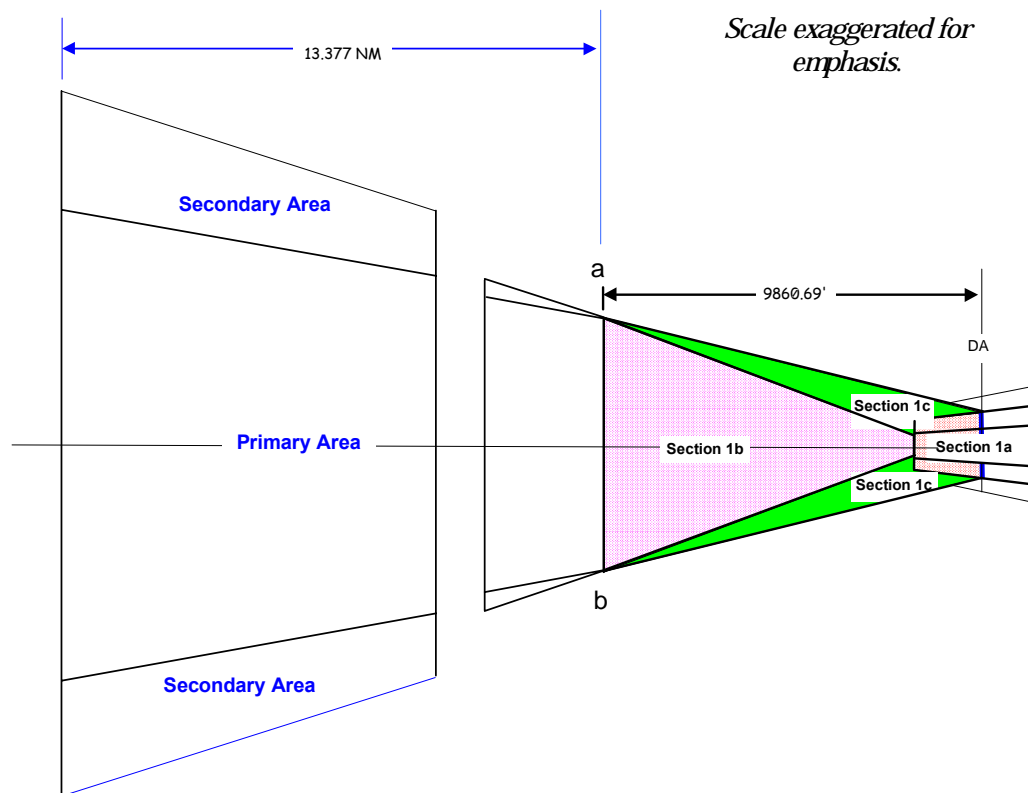

Figure 3-10B. Turning Missed Approach with Turn Fix at Greater than Minimum Distance



3.9.1 e. Section 2. [Non-RNAV]

3.9.1 e. (1) Straight-Ahead (15° or less of final course heading). Section 2 is a 40:1 OCS that starts at the end of section 1 and is centered on the missed approach course. The width increases uniformly from 1 mile at the beginning to 12 miles at a point 13.377 miles from the beginning. A secondary area for reduction of obstacle clearance is identified within section 2. The secondary area begins at zero miles wide and increases uniformly to 2 miles wide at the end of section 2. PCG is required to reduce obstacle clearance in the secondary areas (see figure 3-11A). Use TERPS Volume 1, paragraph 277e, to determine if a climb-in-holding evaluation is required.

Figure 3-11A. Straight Missed Approach

3.9.1

e. (2) Turning Missed Approach. Where turns of MORE than 15° are required, design the procedure to begin the turn at an altitude at least 400 feet above the elevation of the TDZ. Assume the aircraft will be 175 feet above DA at the end of section 1b. Extend section 1b 30.39 feet for each additional foot of altitude necessary before a turn can commence. This point is where section 2 40:1 OCS begins. Specify the “climb to” altitude in the published missed approach procedure. The flight track and outer boundary radii used shall be as specified in TERPS Volume 1, table 5, paragraph 275. The inner boundary line shall commence at the edge of section 1 opposite the MAP. The outer and inner boundary lines shall expand to the width of the initial approach area 13.377 miles from the beginning of section 2. Secondary areas for reduction of obstacle clearance are identified within section 2. The secondary areas begin after completion of the turn (see figure 3-11B). They begin at zero miles wide and increase uniformly to 2 miles wide at the end of section 2. PCG is required to reduce obstacle clearance in the secondary area.

Figure 3-11B. Turning Missed Approach

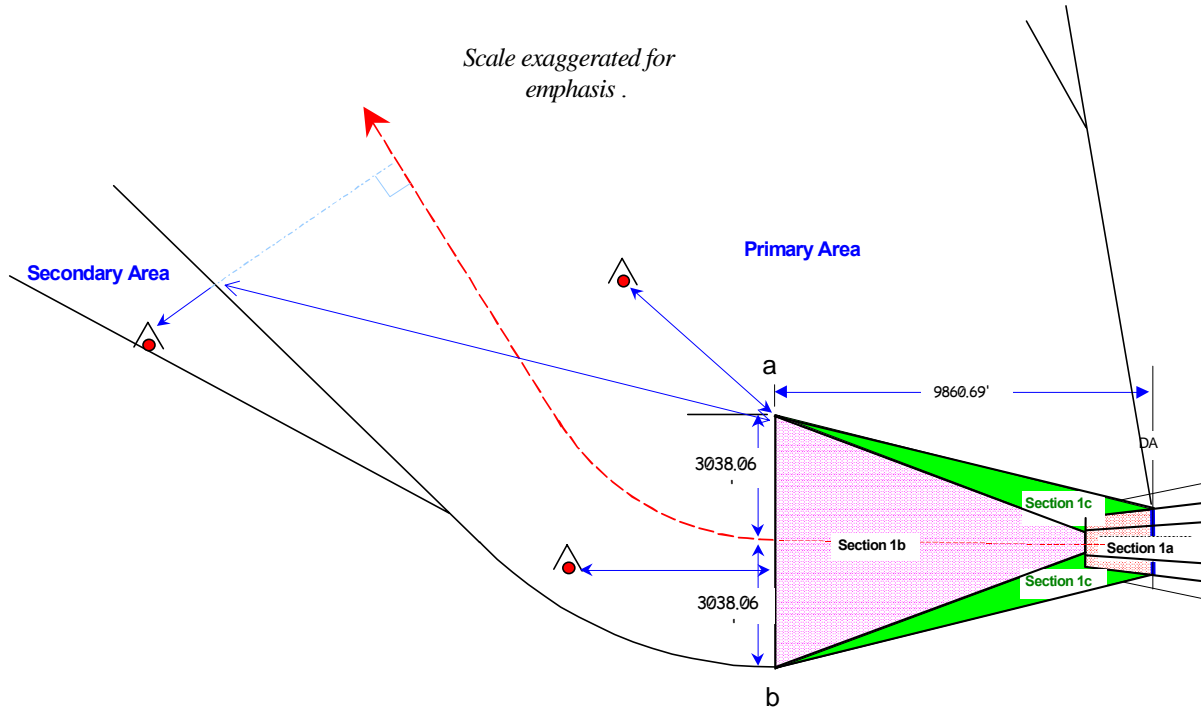

3.9.1 **e. (3) Combination Straight-Turning Missed Approach Procedures.** Use TERPS Volume 1, paragraphs 277d and f to establish the charted missed approach altitude. Use TERPS Volume 1, paragraph 277e to determine if a climb-in-holding evaluation is required.

3.9.2 Missed Approach Climb Gradient (DOD Only).

Where the 40:1 OCS is penetrated and the lowest HAT is required, a mandatory missed approach climb gradient may be specified to provide ROC over the penetrating obstruction. Use the following formula to calculate the climb gradient (CG) in feet per NM.

$$\frac{o - (DA - \tan(\theta)(1460) + 276.52)}{0.76d} = CG \quad \text{Example: } \frac{1849 - (613 - \tan(3)(1460) + 276.52)}{(0.76)(5.26)} = 259.15 \approx 260$$

Where o = MSL height of obstruction
 d = shortest distance (NM) from end of section 1B to obstacle
 θ = glidepath angle

3.9.3 Missed Approach ROC Rationale.

The obstacle clearance concept applied to the departure and missed approach climb maneuver in instrument procedures design is to enable the aircraft to gain sufficient altitude to supply at least the minimum ROC for the subsequent level surface segments of the procedure. The obstacle evaluation method for a climb maneuver is the application of a rising OCS below the minimum climbing flight path. The vertical distance between the climbing flight path and the OCS is ROC. The ROC and OCS slope values are dependent on a minimum aircraft

climb performance of 200 ft/NM (see figure 3-12). Whether the climb is for departure or missed approach is immaterial. The standard for determining OCS slope is that 76% $\left(\frac{19}{25}\right)$ of the altitude gained defines the OCS slope; 24% $\left(\frac{6}{25}\right)$ of the altitude gained defines the ROC value.

Figure 3-12. ROC and OCS Slope Values

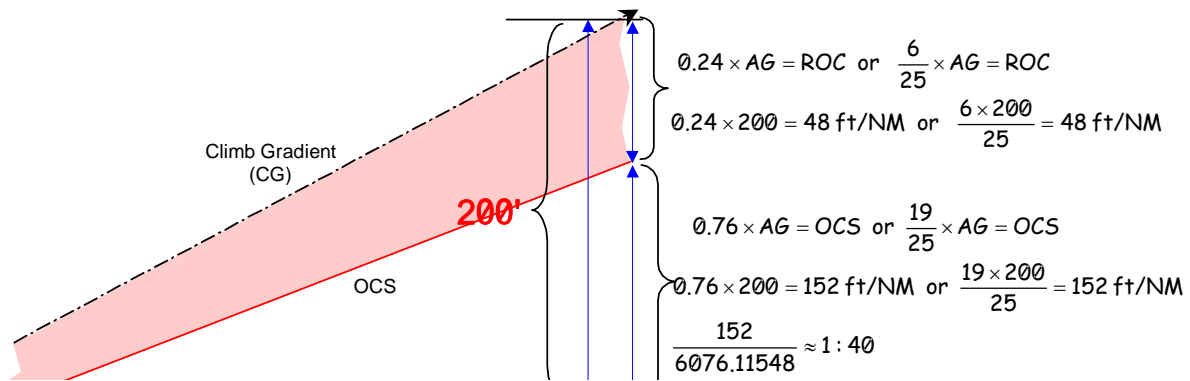

The amount of ROC increases as the aircraft climbs until the point en route or initial segment ROC (1,000/2,000 feet as appropriate) is realized. After this point, application of a sloping surface for obstacle clearance purposes is not required. Where an obstacle penetrates the OCS, a greater than normal climb gradient (greater than 200 ft/NM) is required to provide adequate ROC. Since the climb gradient will be greater than 200 ft/NM, the ROC requirement will be greater than 48 ft/NM ($0.24 \times [Y > 200] = [Z > 48]$). The ROC expressed in ft/NM can be calculated using the formula: $\frac{0.24h}{0.76d}$ or $\frac{6h}{19d}$ where "h" is the height of the obstacle above the altitude from which the climb is initiated, and "d" is the distance in NM from the initiation of climb to the obstacle.

CHAPTER 4.

BAROMETRIC VERTICAL NAVIGATION (BARO VNAV)

4.0 GENERAL.

Design LNAV/VNAV approach procedures under these criteria. Baro VNAV operations are not authorized where remote altimeter is used, or in areas of precipitous terrain. The allowable range of glidepath angles is:

MINIMUM glidepath angle is 2.75°;
OPTIMUM glidepath angle is 3.00°;
MAXIMUM glidepath angle is 3.5°.

4.1 PUBLISHING ON RNAV CHARTS.

When published on an RNAV approach chart that depicts multiple lines of minima (LNAV/VNAV, LNAV, etc.), the TCH, GPA, course alignment, PFAF/FAF, and missed approach route and altitudes shall be identical for all depicted procedures. When minimums are based on remote altimeter and/or temperature settings, or the final segment overlies precipitous terrain, annotate the chart with a note to indicate Baro VNAV is not authorized. Where Baro VNAV is authorized, publish the minimum temperature for which the procedure was designed.

4.2 GROUND INFRASTRUCTURE.

If the airport obstacle free zones or the POFA are penetrated, LOWEST minimums are 300-foot ceiling and 3/4 mile visibility.

4.3 GLIDEPATH QUALIFICATION SURFACE (GQS).

Penetrations of the GQS are not authorized. Apply paragraph 2.12.

4.4 FINAL APPROACH SEGMENT.

LNAV/VNAV procedures are based on the LNAV trapezoid. The Baro VNAV vertical surfaces conform to the LNAV trapezoid.

4.4.1 Area. See figure 4-1A.

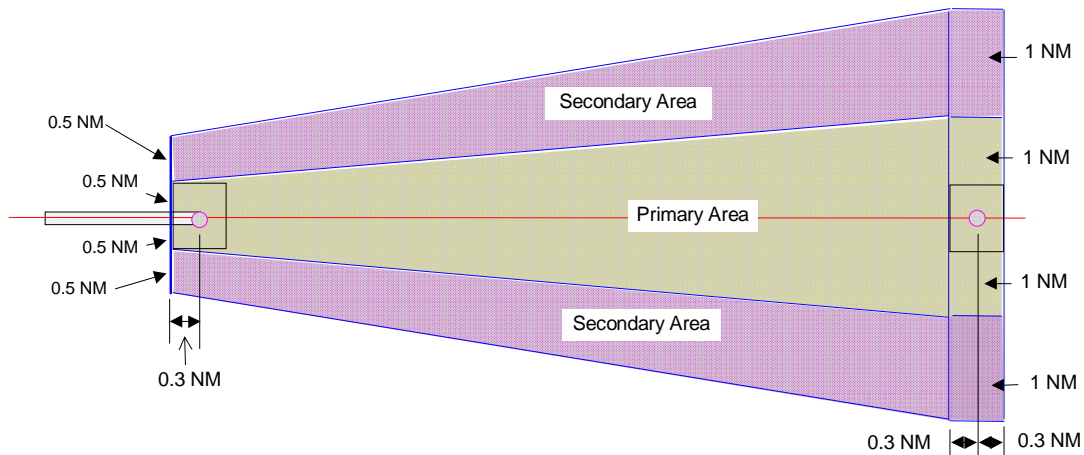
Figure 4-1A. LNAV-VNAV Primary and Secondary Areas**4.4.2 Alignment.**

The default final course aiming point is the LTP/FTP. OPTIMUM alignment is with the runway centerline (RCL) extended. The MAXIMUM offset from RCL is 15°. Approaches serving category A and B aircraft only may be designed with the offset course passing through the LTP/FTP regardless of degree of offset (see figure 4-1B). Where larger aircraft categories (CAT C, D, and E) are accommodated, the offset course must cross the RCL extended at least a MINIMUM distance from the RWT determined by the degree of offset, except as noted below:

- 4.4.2 a. Where the FAC is $\leq 5^\circ$ from the RCL alignment, the FAC shall cross the RCL at or outside the RWT.**
- 4.4.2 b. When the FAC is $> 5^\circ$ from RCL alignment, the FAC shall cross the RCL at least 1,500 feet from the RWT.**
- 4.4.2 c. When the FAC is $> 10^\circ$ from RCL alignment, the FAC shall cross the RCL at least 3,000 feet from the RWT.**

NOTE: A FAC that intersects the RCL inside RWT, does not intersect the RCL extended or intersects at a distance greater than 3,000 feet from RWT may be established provided that the course lies laterally within 500 feet of the extended RCL at a point 3,000 feet outward from the RWT.

Figure 4-1B. Offset Final Course and RCL Extended Crossing Points

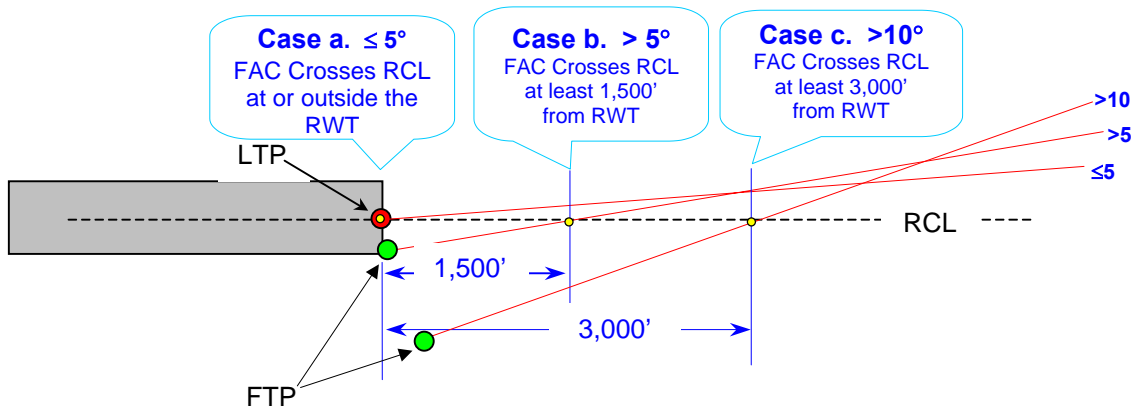

4.4.3 Length.

The primary OCS begins at the earliest point the FAF can be received and extends 0.3 NM past the RWT or FTP (see figures 4-1A, 4-1B, and 4-2).

Figure 4-2. End of Final Trapezoid, 15° Offset

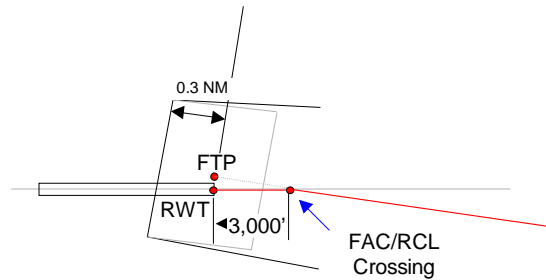

4.4.4 Width.

4.4.4 a. Primary Area.

Calculate the perpendicular distance (D_Y) from the course extended to the outer boundary of the primary area for any distance (D) from RWT or FTP using the following formula:

$$D_Y = \frac{0.5 \text{ NM}}{L} \times (D + 1822.83) + 3038.06$$

Where D = the distance in feet from RWT or FTP along course centerline

L = the final length in NM from plotted position of FAF to plotted position of RWT or FTP

4.4.4 b. Secondary Area.

The width of the secondary area is equal to the 1/2 width of the primary at any distance "D" from RWT or FTP (see paragraph 4.4.4a).

4.4.5 Obstacle Clearance Between RWT and 250' ASBL Point (see figure 4-3).

Figure 4-3. Baro VNAV OCS's

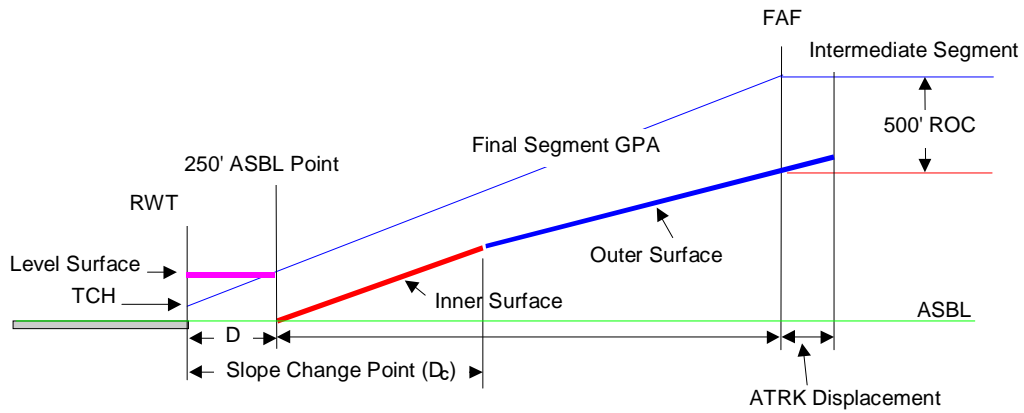

The area between the RWT or FTP and the 250 feet above ASBL point consists of primary and secondary ROC areas. Apply ROC in the appropriate shaded area below to arrive at a preliminary DA (pDA) (see figure 4-4).

Figure 4-4. Obstacle Clearance Inside the 250 Feet Above ASBL Point

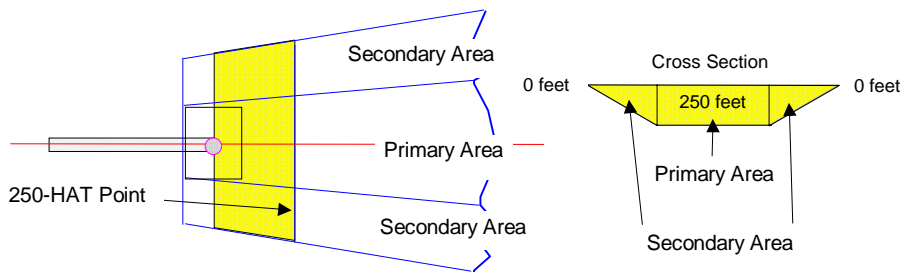

In the primary area, apply 250 feet ROC to the highest obstruction (see figure 4-4). Calculate secondary area ROC using the following formulae:

$$D_P = \frac{3,038.06}{L} \times (D_X + 1,822.83) + 3,038.06$$

$$\text{Example: } \frac{3,038.06}{28,557.74} \times (3,000 + 1,822.83) + 3,038.06 = 3,551.13$$

$$D_S = D_P$$

$$ROC_S = \frac{250}{D_S} \times ([2 \times D_S] - D_Y)$$

$$\text{Example: } \frac{250}{3,551.15} \times ([2 \times 3,551.13] - 4,200) = 204.32$$

Where

L = final length in feet (plotted position of FAF to plotted position of RWT or FTP).

DP = the distance in feet from course centerline to the primary area outer boundary.

D_S = the width of the secondary area at distance D_X.

D_X = the distance in feet from RWT or FTP to the obstacle measured along course centerline.

D_Y = the perpendicular distance in feet from course centerline to the obstacle.

Determine the pDA by adding the appropriate ROC value to the controlling obstruction height and round up to the next higher 20-foot increment.

4.4.6 Inner Surface.

The inner surface originates at the point on the ASBL corresponding distance from RWT that the glidepath reaches 250 feet above ASBL (see figure 4-3). Calculate the distance (D₂₅₀) from RWT or FTP to the OCS origin using the following formula:

$$D_{250} = \frac{250 - TCH}{\tan(\theta)} \quad \text{Example: } \frac{250 - 53}{\tan(3)} = 3758.98$$

Where θ = glidepath angle

Determine the slope of the inner surface (S_V) as follows:

STEP 1: Obtain the mean low temperature of the coldest month of the year for the last five years of data. If the data is given in Fahrenheit (°f), convert the temperature to Celsius (°c) and enter table 4-1. Use the following formulae to convert between Celsius and Fahrenheit temperatures:

$$^{\circ}\text{C} = \frac{^{\circ}\text{F} - 32}{1.8} \quad \text{Example: } \frac{76 - 32}{1.8} = 24.44^{\circ}\text{C}$$

$$^{\circ}\text{F} = (1.8 \times ^{\circ}\text{C}) + 32 \quad \text{Example: } (1.8 \times 24.44) + 32 = 75.99^{\circ}\text{F}$$

STEP 2: Convert the mean temperature into a deviation from ISA using the following formula:

$$\text{deviation} = ^{\circ}\text{C} - \left[15^{\circ}\text{C} - \left(\frac{\text{Airport Elevation}}{500} \right) \right] \quad \text{Example: } -28 - \left[15^{\circ}\text{C} - \left(\frac{1,528}{500} \right) \right] = -39.9^{\circ}$$

Round deviation to the next lower 5°C increment. Use this rounded deviation or -15°C, whichever is lower, and the GPA to find the surface slope from table 4-1.

Table 4-1. S_V Considering GPA and International Standard Atmosphere (ISA) Temperature Deviation

ISA (C) DEV	2.7	2.8	2.9	3.0	3.1	3.2	3.3	3.4	3.5	3.6	3.7	3.8
-10	23.2	22.4	21.7	21.0	20.4	19.8	19.3	18.8	18.3	17.8	17.4	17.0
-15	23.8	23.0	22.2	21.6	20.9	20.3	19.8	19.3	18.8	18.3	17.9	17.5
-20	24.4	23.6	22.9	22.2	21.5	20.9	20.3	19.8	19.3	18.8	18.4	18.0
-25	25.1	24.3	23.5	22.8	22.1	21.5	20.9	20.4	19.9	19.4	18.9	18.5
-30	25.8	25.0	24.2	23.4	22.8	22.1	21.5	21.0	20.5	20.0	19.5	19.1
-35	26.6	25.7	24.9	24.1	23.4	22.8	22.2	21.6	21.1	20.6	20.1	19.6
-40	27.4	26.5	25.7	24.9	24.2	23.5	22.9	22.3	21.7	21.2	20.7	20.3
-45	28.2	27.3	26.5	25.7	24.9	24.2	23.6	23.0	22.4	21.9	21.4	20.9
-50	29.1	28.2	27.3	26.5	25.8	25.0	24.4	23.8	23.2	22.6	22.1	21.6

NOTE: IF the glidepath angle falls between table values, use the higher value.

4.4.7 Outer Surface.

Calculate the slope of the outer surface (S_W) appropriate for the glidepath angle (θ) using the following formula: $S_W = \frac{102}{\theta}$ The outer surface begins at point "c"

and ends at the earliest point the FAF can be received (see figure 4-3).

Calculate the distance (D_C) from RWT or FTP to point C using the following formula

$$D_C = \frac{(a \times S_W) - (200 \times S_V)}{(S_W - S_V)}$$

Where a=distance from RWT or FTP
to OCS origin ($D_{25\theta}$)

4.4.8 Height of the OCS.

4.4.8 a. Calculate the height (I_z) above ASBL of the inner surface using the following formula:

$$Iz = \frac{D_o - D_{250}}{S_V}$$

Where D_o = the distance in feet from the RWT or FTP to the obstacle

D_{250} = the distance from the RWT or FTP origin to the inner surface origin

- 4.4.8 b. Calculate the height (O_z) above ASBL of the outer OCS using the following formula:**

$$O_z = \frac{(D_o - 200) \times \text{GPA}}{102}$$

- 4.4.8 c. The secondary OCS has a slope of 7:1 measured perpendicular to the segment centerline. To evaluate the height of a secondary OCS obstruction, reduce the obstruction height by the amount of secondary surface rise from the edge of the primary OCS (see figure 4-5). Then evaluate the revised height of the obstruction against the height of the primary OCS abeam the obstruction.**

Figure 4-5. Secondary OCS Evaluation

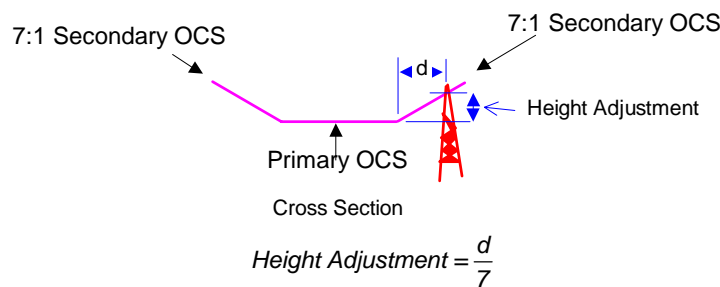

Where d = distance in feet from edge of primary OCS measured perpendicular to the segment centerline.

4.4.9 OCS Penetrations.

Obstructions should not penetrate the OCS. If the OCS is clear, publish the pDA value. If the OCS is penetrated, take one of the following actions. These actions are listed in order of preference.

ACTION 1: Remove or adjust the obstruction location and/or height.

ACTION 2: Raise glidepath angle.

ACTION 3: Adjust DA.

4.4.9 a. Adjustment of DA for Penetration of INNER SURFACE.

CASE 1: If elevation (revised elevation if paragraph 4.4.8c applied) of the obstacle is less than the elevation of point C ($C_{\text{elevation}}$):

$$C_{\text{elevation}} = E + \frac{D_C - D_{250}}{S_V}$$

$$DA_{\text{adjusted}} = E + \tan(\theta) \left(\left(D_O + \frac{TCH}{\tan(\theta)} \right) + (p \times S_V) \right)$$

Where θ = glidepath angle

D_O = distance (ft) to obstacle from LTP measured parallel to FAC

p = amount of penetration (ft)

S_V = slope of inner surface

E = LTP elevation (ft)

CASE 2: If the elevation (revised elevation if paragraph 4.4.8c applied) of the obstacle is equal to or greater than the elevation of point C:

$$DA_{\text{adjusted}} = E + \tan(\theta) \left[([h-c]S_W) + D_C + \frac{TCH}{\tan(\theta)} \right]$$

Where h = obstacle MSL elevation (revised elevation if para 4.4.8c applied)

c = elevation (MSL) of point C

4.4.9

b. Adjustment of DA for penetration of OUTER SURFACE (see figure 4-6):

$$DA_{\text{adjusted}} = E + \tan(\theta) \left[(pS_W) + D_O + \frac{TCH}{\tan(\theta)} \right]$$

$$\text{Distance LTP to } DA_{\text{adjusted}} = \frac{DA_{\text{adjusted}} - E}{\tan(\theta)} - \frac{TCH}{\tan(\theta)}$$

Where DA_{adjusted} = Adjusted DA (MSL)

Figure 4-6. DA ADJUSTMENT

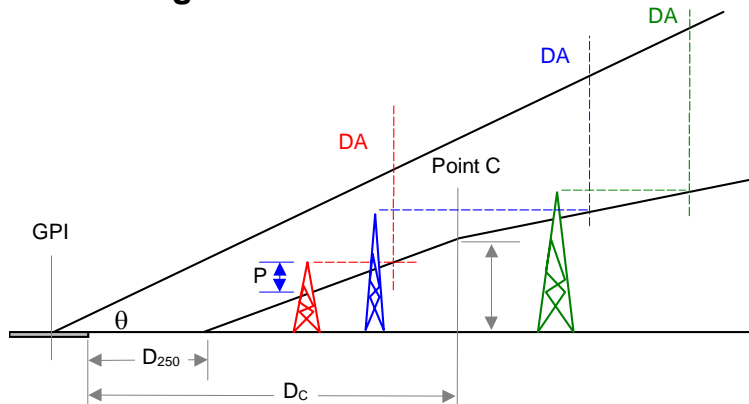

4.5

VISIBILITY MINIMUMS.

To determine visibility minimums, refer to TERPS Volume 1, chapter 3 for localizer procedures.

4.6 MISSED APPROACH SEGMENT.

Height loss is assumed after DA. The missed approach area begins at the cd line prior to the DA point. Apply RNAV departure criteria (Order 8260.44) from the segment origin to the missed approach holding fix. Locate the first fix encountered after DA at least 9,114 feet from the ab line and a maximum of 5 NM. If a turn is associated with a fly-by fix, the minimum distance is 9,114+DTA (see figures 4-7 and 4-8A and 4-8B).

Figure 4-7. Straight Missed Approach Surfaces

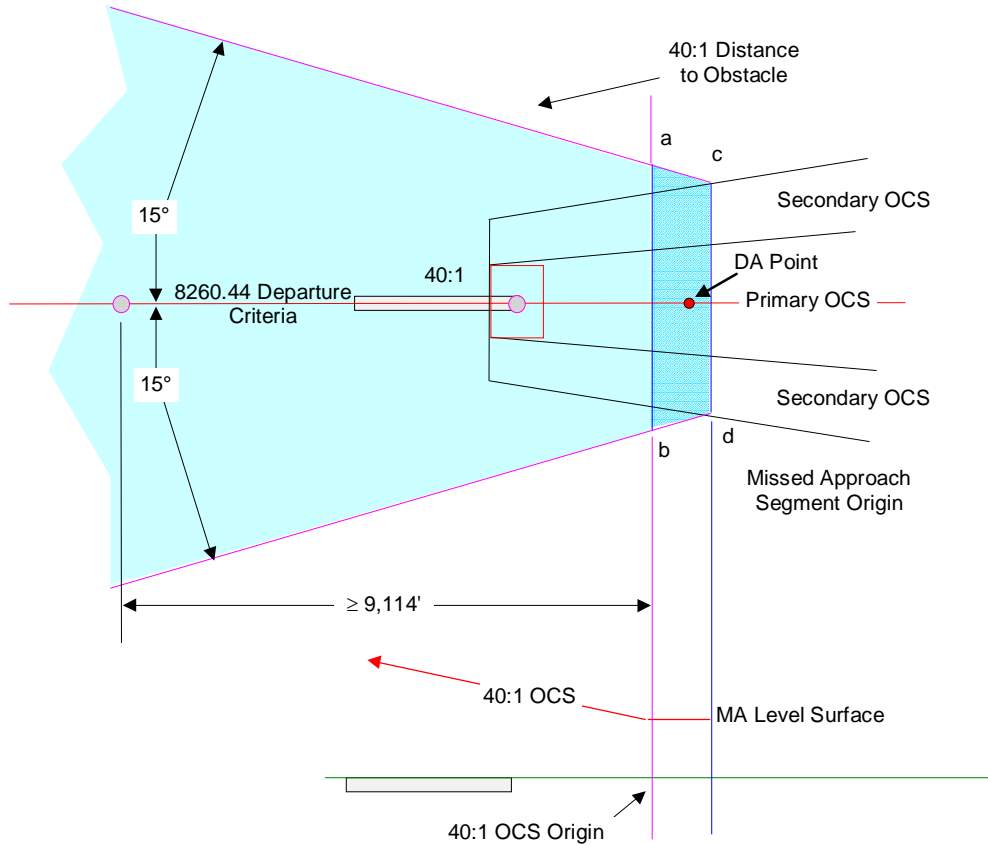

**Figure 4-8A. Turning Approach Surfaces
Minimum Distance from DA to Turn Fix**

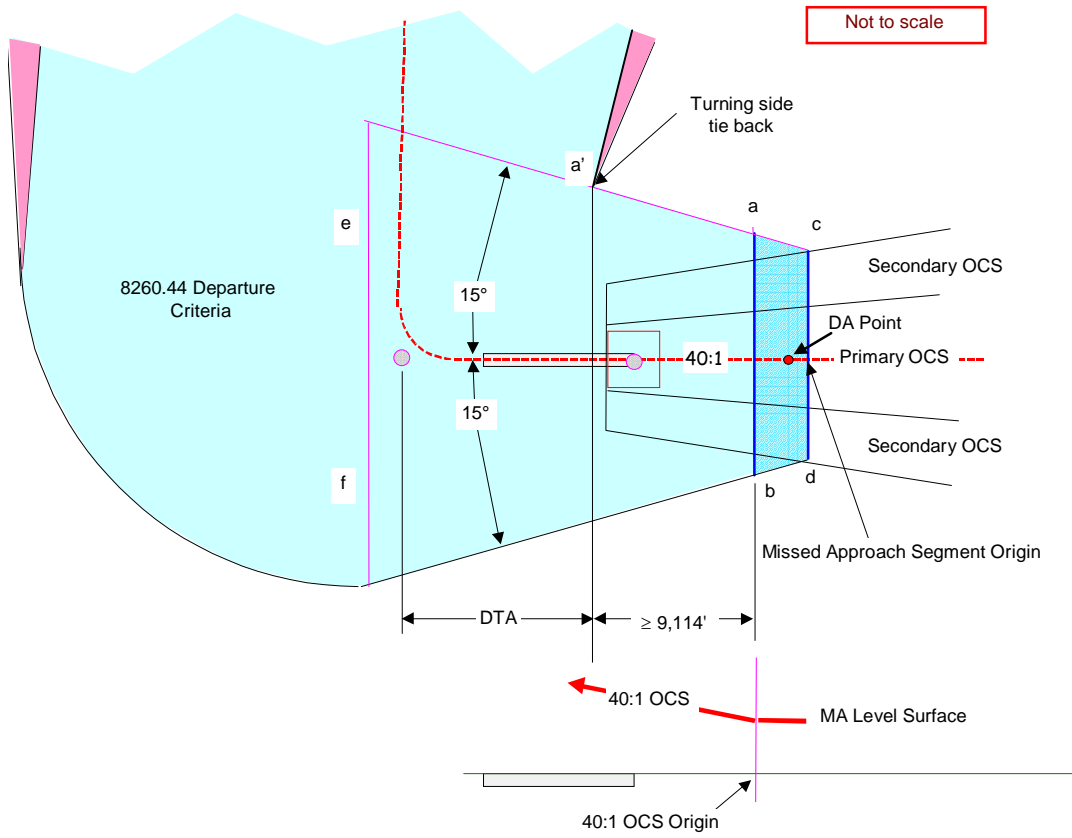
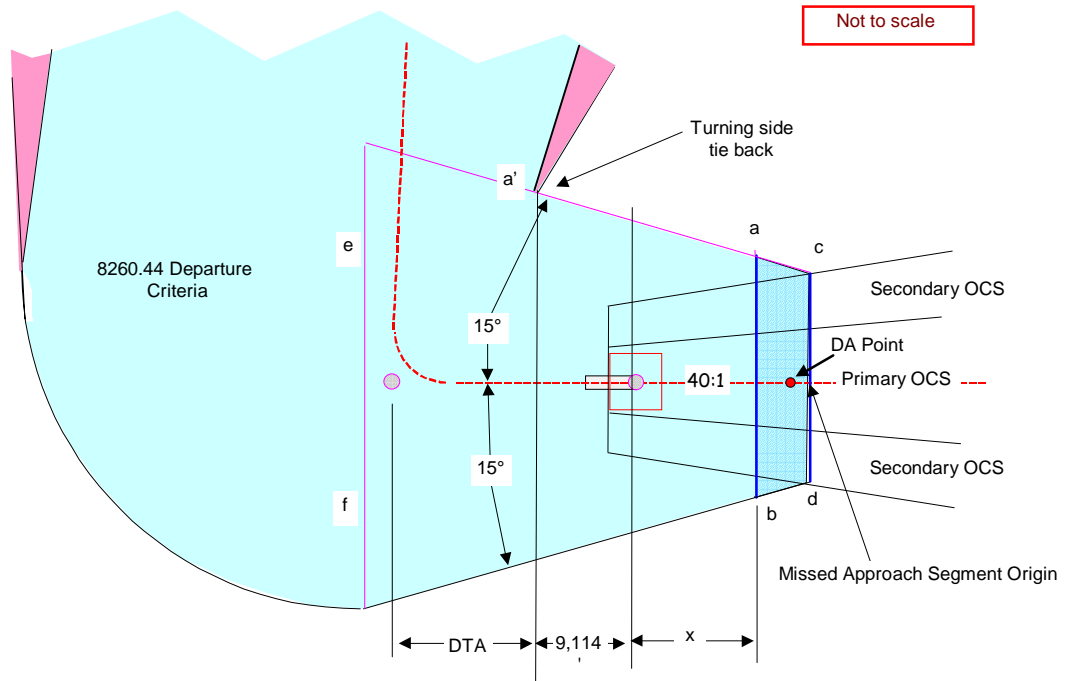

Figure 4-8B. Turning Approach Surfaces Greater than Minimum Distance from DA to Turn Fix



4.6.1 Area.

4.6.1 a. Level Surface. See figure 4-9.

The level surface accounts for possible along track errors inherent with barometric altimetry and allows an aircraft to lose (dip down) 50 feet prior to commencing climb.

4.6.1 a. (1) Length. Calculate the distance (D_{cd}) from RWT to the **origin** of the MA segment (cd line), and the distance (D_{ab}) from RWT to the end of the level surface (ab line), using the following formulae:

$$D_{cd} = \frac{DA - (E + TCH)}{\tan(\theta)} - \frac{50}{\tan(\theta)} + 1822.83$$

$$D_{ab} = D_{cd} - 3645.66$$

Where E = RWT elevation
 θ = GPA

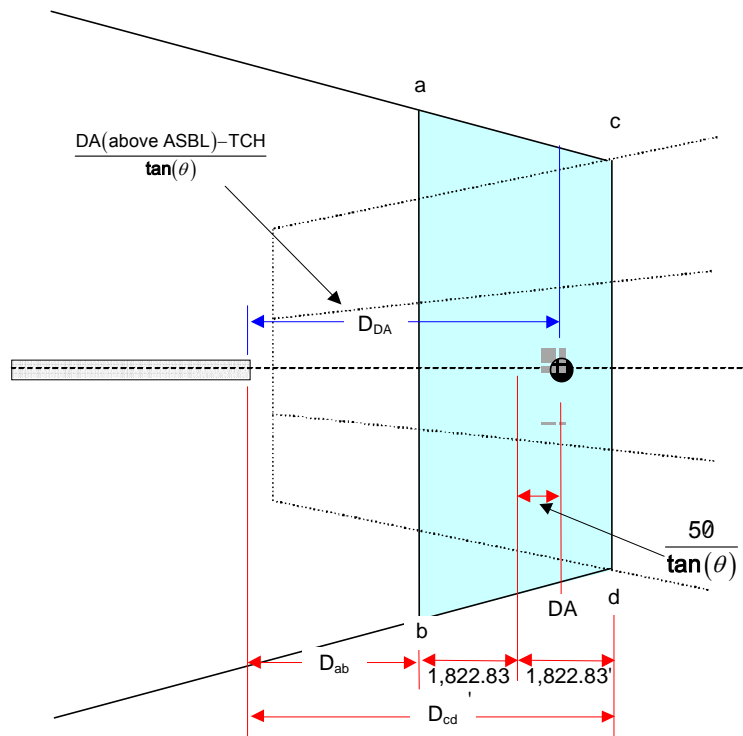
Figure 4-9. Level Surface

4.6.1 **a. (2) Width.** The area splays at 15° relative to the MA course beginning at the secondary outer boundary at the cd line (see figure 4-9).

4.6.1 **a. (3) OCS.** A level surface overlies the primary area. Where obstructions penetrate the OCS, increase the DA by the value of the penetration. The height of the MA LEVEL OCS (MSL) is determined by the formula:

$$h_{mas} = DA - ROC$$

4.6.1 **b. 40:1 Surface.** Apply Order 8260.44 criteria.

4.6.1 **b. (1) Length.** The 40:1 surface begins at the ab and extends along the MA course until the clearance limit.

4.6.1 **b. (2) Width.** The primary area splays as specified in Order 8260.44 relative to the MA course beginning at the final primary outer boundary at the cd line (see figure 4-9).

4.6.1 **b. (3) OCS.** Where obstructions penetrate the OCS, increase the DA by the value ($DA_{\text{adjustment}}$) calculated by the following formula:

$$DA_{\text{adjustment}} = \frac{\theta(40p)}{102}$$

Where p = amount of penetration in feet

4.6.1 c. Missed Approach Altitude.

4.6.1 **c. (1) Straight Missed Approach Procedures.** Use TERPS paragraphs 274b and d to establish the charted missed approach altitude. Use TERPS paragraph 274c to determine if a climb-in-holding evaluation is required.

4.6.1 **c. (2) Combination Straight Turning Missed Approach Procedures.** Use TERPS paragraphs 277d and f to establish the charted missed approach altitude. Use TERPS paragraph 277e to determine if a climb-in-holding evaluation is required.

THIS PAGE INTENTIONALLY LEFT BLANK

5/15/02

8260.3B CHG 19
Appendix 1

Policy Memo
Dec 21 2007

**APPENDIX 1. CATEGORY (CAT) II AND III
PRECISION MINIMUMS REQUIREMENTS**

RESERVED

THIS PAGE INTENTIONALLY LEFT BLANK

Appendix 2
Simultaneous Independent Parallel
Instrument Approaches [SIPIA] – Widely Spaced Runways

1. Overview. This appendix defines requirements for approaches used to support SIPIA operations to parallel runways where the runway centerlines are separated by 4,300 ft or more. See JO 7210.3, Facility Operation and Administration, and JO 7110.65, Air Traffic Control for operational and equipment requirements. See the Pilot/Controller Glossary for definition of a parallel runway. Requirements for other simultaneous parallel approach operations are defined in ATC directives or other Flight Standards criteria.

2. Radar monitoring/Instrument Approaches. SIPIA operations require

a. Radar, communications, and procedures as specified by the applicable ATC directives.

b. Approaches designed to support SIPIA operations with at least one line of vertically guided minima and which include all chart notes specified by Order 8260.19, Flight Procedures and Airspace. The following types of approaches support SIPIA operations:

(1) ILS. When localizer minimums are on the same chart, SIPIA operations may continue during a temporary glide slope outage. Continued use during outages exceeding 29 days requires AFS-400 approval.

(2) RNAV (GPS) with LPV and/or LNAV/VNAV minimums.

(3) RNAV (RNP).

3. Runway Spacing. The required spacing between runways/procedure final approach courses (FAC) for dual/triple widely spaced SIPIA operations is in accordance with Air Traffic Directives as established by FAA Flight Standards. Quadruple SIPIA operations are not covered by this directive and require a site-specific Flight Standards Flight Systems Laboratory (AFS-450) safety analysis.

4. Approach Procedures. Instrument approach procedures used for widely spaced SIPIA operations must comply with the applicable design standard(s), except as follows:

a. Missed approaches with radius-to-fix (RF) turns require AFS-400 approval.

b. Dual widely spaced SIPIA operations. Missed approach courses must have a combined divergence of at least 45 degrees.

c. Triple widely spaced SIPIA operations. The missed approach course for the center runway is a continuation of the FAC. The course for each 'outboard' runway must diverge at least 45 degrees from the center runway in opposite directions. At least one outside parallel shall have a turn height specified that is not greater than 500 ft above the TDZE/THLD elevation for that runway.

have a turn height specified that is not greater than 500 ft above the TDZE/THLD elevation for that runway.

d. Quadruple widely spaced SIPIA operations. Course divergence is as specified by AFS-450 safety analysis.

e. Where an alternate missed approach has been established for an approach authorized for use during widely spaced SIPIA operations, it must also comply with the preceding restrictions.

5. No Transgression Zone (NTZ) and Normal Operating Zones (NOZ) are established by ATC for each adjacent runway pair used during widely spaced SIPIA operations.

a. The NTZ is 2,000 ft wide equidistant between the approach courses for the runway pair. It begins at the farthest point in the adjacent runway pair where any aircraft established on the approach is permitted to lose vertical/lateral separation (point "S"). It ends 0.5 NM past the farthest departure end runway (DER) in the pair or where the missed approach tracks diverge, whichever occurs last (see figures A2-1 and A2-2).

Note: The NTZ dimensions are not affected by the point where ATC is permitted to discontinue radar monitoring.

b. The area remaining between the approach courses and the edge of the NTZ is the NOZ.

Figure A2-1. No Transgression and Normal Operating Zones (Dual Approach).

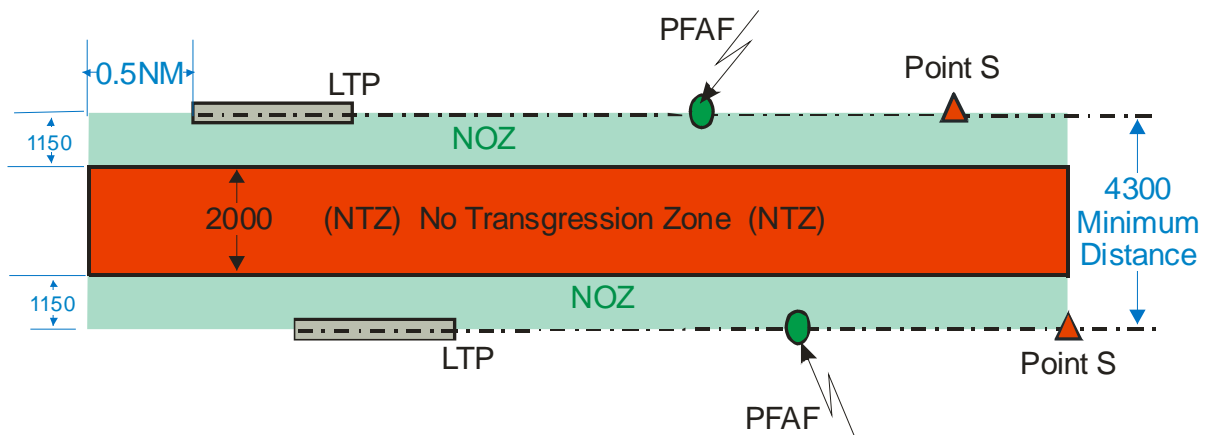
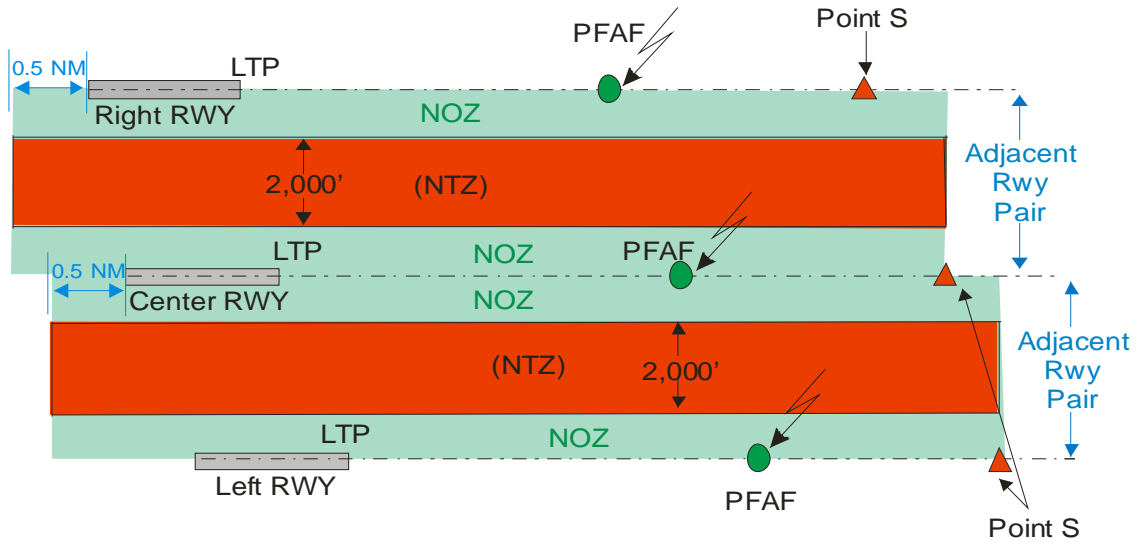

Figure A2-2. No Transgression and Normal Operating Zones (Triple Approach).



THIS PAGE INTENTIONALLY LEFT BLANK

APPENDIX 3. CLOSE PARALLEL ILS/MLS APPROACHES

1.0 BACKGROUND.

Extensive tests have disclosed that under certain conditions, capacity at the nation's busiest airports may be significantly increased with independent simultaneous parallel approaches to runways that are more closely spaced than the minimum of 4,300 feet. Tests have shown that a reduction in minimum separation between parallel runways may be achieved by use of high update radar with high-resolution displays and automated blunder alerts.

2.0 TERMINOLOGY.

2.1 AUTOMATED ALERT.

A feature of the PRM that provides visual and/or audible alerts to the monitor controller when an aircraft is projected to enter or has entered the NTZ. Paragraph 3.1.2 defines the precision runway monitor (PRM) systems alerts.

2.2 BREAKOUT.

A technique to direct aircraft out of the approach stream. In the context of close parallel operations, a breakout is used to direct threatened aircraft away from a deviating aircraft.

2.3 CLOSE PARALLELS.

Two parallel runways whose extended centerlines are separated by at least 3,400 feet, but less than 4,300 feet, having a precision runway monitoring system that permits simultaneous independent ILS/MLS approaches. Runways are separated by less than 3,400 to 3,000 feet with a localizer offset of not more than 3.0°.

2.4 E-SCAN RADAR.

An electronically scanned phased array radar antenna that is cylindrical and stationary. It consists of interrogators and a surveillance processor providing an azimuth accuracy of at least 1 milliradian (0.057°) remote monitoring subsystem (RMS) and an update interval of not more than 1.0 second.

2.5 LOCALIZER/AZIMUTH OFFSET.

An angular offset of the localizer/azimuth from the runway extended centerline in a direction away from the no transgression zone (NTZ) that increases the normal operating zone (NOZ) width.

2.6 MONITOR ZONE.

The monitor zone is the volume of airspace within which the final monitor controllers are monitoring close parallel approaches and PRM system automated alerts are active.

2.7 NO TRANSGRESSION ZONE (NTZ).

The NTZ is a 2,000-foot wide zone, located equidistant between parallel runway final approach courses in which flight is not allowed (see figure A3-1).

2.8 NORMAL OPERATING ZONE (NOZ).

The NOZ is the operating zone within which aircraft flight remains during normal independent simultaneous parallel approaches (see figure A3-1.)

2.9 PRECISION RUNWAY MONITOR (PRM).

A specialized ATC radar system providing continuous surveillance throughout the monitoring control zone. It includes a high accuracy, high update rate sensor system, and for each runway, a high resolution color FMA with automated alerts. The PRM system provides each monitor controller with a clear, precise presentation of aircraft conducting approaches.

3.0 GENERAL.

Criteria contained in this appendix are designed for independent simultaneous precision ILS or MLS operations to dual parallel runways with centerlines separated by at least 3,000 feet, but less than 4,300 feet. Simultaneous close parallel operations at airport elevations above 1,000 feet MSL and deviations from these criteria or glidepath angles above the U.S. civil standard of 3.0° shall not be established without approval from the Flight Standards Service, FAA, Washington, DC. When runway spacing is less than 3,400 feet, but not less than 3,000 feet, the localizers/azimuth stations in the close runway pair must be aligned at least 2-1/2° divergent from each other, but not more than 3.0°, and an electronically scanned (E-Scan) radar with an update interval of 1.0 second must be employed. All close parallel ILS/MLS operations require final approach radar monitoring, accurate to within 1.0 milliradian, an update interval of 1.0 second, and a final monitor aid (a high resolution display with automated blunder alerts). In these criteria, ILS "glide slope/localizer" terms are synonymous to and may be used inter-changeably with MLS "elevation/azimuth" terms. Independent simultaneous close parallel approaches without altitude separation should not be authorized at distances greater than 10 NM from threshold. If Air Traffic Control (ATC) systems and procedures are established which assure minimal NTZ intrusions, this distance may be extended up to 12.5 NM. A separate instrument approach chart described as a special close parallel ILS/MLS procedure shall be published for each runway in the close parallel pair of runways. This special close parallel ILS/MLS procedure is to be identified in accordance with paragraph 3.1. A standard ILS/MLS procedure

may also exist or be published for each of the runways. During close parallel ILS/MLS operations, the close parallel ILS/MLS may overlay the existing standard ILS/MLS procedure, provided that spacing localizer/azimuth alignment is less than 3,400 feet and the missed approaches diverge. A breakout obstacle assessment specified in Volume 3, appendix 4, Obstacle Assessment Surface Evaluation for Simultaneous Parallel Precision Operations, shall be completed as part of the initial evaluation for parallel operations.

3.1 SYSTEM COMPONENTS.

Simultaneous close parallel approach procedures are not authorized if any component of the PRM system is inoperative. System requirements for simultaneous close parallel approach procedures are:

3.1.1 **ILS/MLS.** A full ILS or MLS on each runway.

3.1.2 **PRM.** A PRM system includes the following:

3.1.2 **a. Radar.** Phased array electronically scanned (E-Scan) antenna; update intervals of 1.0 second.

3.1.2 **b. Final Monitor Aid (FMA).** Large (not less than 20" x 20"), high resolution (100 pixels/inch minimum), color monitors with associated visual and audible alerts.

3.1.2 **b. (1) Caution Alert.** A caution alert when the system predicts that an aircraft will enter the NTZ within 10 seconds (e.g., the target symbol and data block change from green to yellow and a voice alert sounds).

3.1.2 **b. (2) Warning Alert.** A warning alert when the aircraft has penetrated the NTZ (e.g., the target symbol and data block change to red).

3.1.2 **b. (3) A Surveillance Alert.** A surveillance alert when the track for a monitored aircraft inside the monitor zone has been in a coast state for more than three consecutive updates (e.g., the target symbol and data block change to red).

3.2 PROCEDURE CHARTING.

Volume 1, paragraph 161, applies, except where a separate procedure is published. In this case, "**ILS/MLS PRM**" should precede the approach title identification; e.g., "**ILS PRM, RWY 27R**" (simultaneous close parallel). Notes for approach charts for use in the close parallel operation shall be published in bold and caps as follows: "**SIMULTANEOUS CLOSE PARALLEL APPROACHES AUTHORIZED WITH RUNWAYS (NUMBER) L/R**" and "**LOCALIZER ONLY NOT AUTHORIZED DURING CLOSE-PARALLEL OPERATIONS.**" The following shall also be noted: "**DUAL VHF COMM**

REQUIRED,” “MONITOR PRM CONTROLLER (FREQ) ON RWY () L, (FREQ) ON RWY () R,” and “SEE ADDITIONAL REQUIREMENTS ON ADJACENT INFORMATION PAGE.”

4.0 FEEDER ROUTES AND INITIAL APPROACH SEGMENT.

Volume 3, chapter 2, paragraph 2.3 applies, except as stated in this order. The initial approach shall be made from a NAVAID, fix, or radar vector. Procedure turns and high altitude penetration procedures shall not be authorized.

4.1 ALTITUDE SELECTION.

Altitudes selected shall provide obstacle clearance requirements and a minimum of 1,000 feet vertical separation between aircraft on the two parallel final approach courses in the interval from localizer intercept to glide slope capture.

4.2 LOCALIZER INTERCEPT POINT.

Apply chapter 2 of this Volume, except optimum localizer intercept angles are 20° or less and the maximum intercept angle shall not exceed 30°.

4.3 NTZ.

An NTZ is established and depicted on the FMA as a protected zone 2,000 feet wide, equidistant between parallel runway centerlines, beginning from the point where adjacent inbound aircraft first lose 1,000 feet of vertical separation, and extends to 0.5 NM beyond the farthest departure end of runway (DER), or the point where a combined 45° divergence occurs, whichever is farthest. The beginning of the NTZ for the final segment should begin at the most distant PFAF (see figure A3-1). Where an offset localizer is determined to provide operational advantage, the NTZ shall be established for the final segment equidistant between adjacent final approach courses beginning and ending as stated above.

4.4 NOZ.

An NOZ is established so that the NOZ for each close parallel runway is not less than 700 feet wide on each side of the approach course at any point. The width of the NOZ is equal on each side of the final approach course centerline, and the half-width is defined by the distance from the nearest edge of the NTZ to the final approach course centerline. The length of the NOZ equals the length of the NTZ. Each parallel runway provides an NOZ for the final and missed approach segments that equal the length of the NTZ (see figure A3-1)

Figure A3-1. Examples of Close Parallel Finals and Missed Approach Segments, Runway Spacing 3,000' and 3,400'

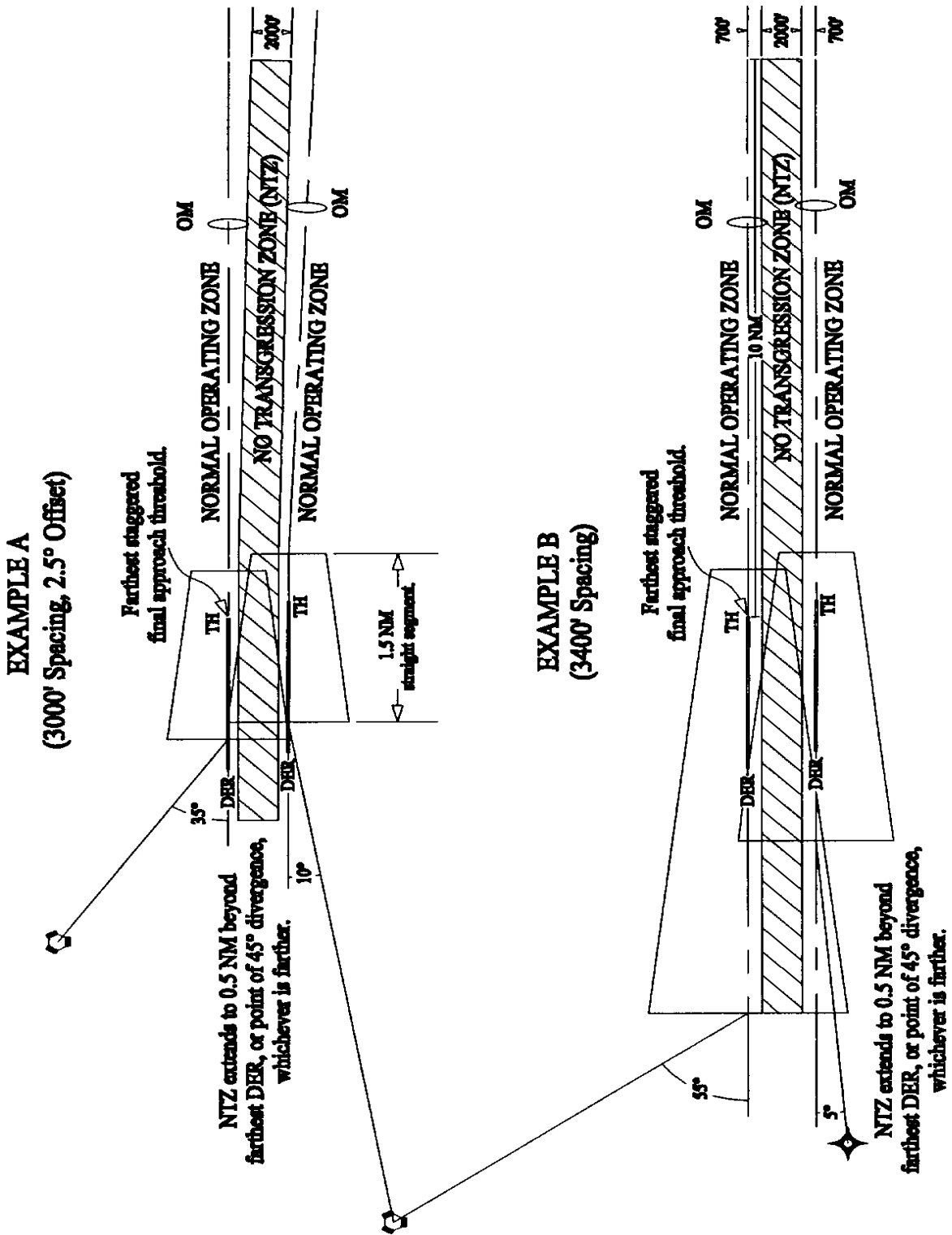

5.0 INTERMEDIATE APPROACH SEGMENT.

Chapter 2, paragraph 2.3, of this Volume applies, except where close parallel procedures have a straight intermediate segment aligned with the final approach course. Where an existing ILS/MLS procedure is published with a transition intercept angle greater than 30° which cannot be reduced, a separate close parallel procedure shall be established with intercept angles of less than 30°.

6.0 FINAL APPROACH SEGMENT.

Volume 3 chapter 3 applies. In addition to these criteria, independent simultaneous approaches to close parallels runways require the following:

6.1 CLOSE PARALLEL APPROACH RUNWAY SEPARATION.

Approaches shall have a minimum of 3,400 foot separation between the parallel final approach courses.

6.2 PRM.

A PRM system must be in operation and providing service in accordance with paragraph 3.1.2.

6.3 NTZ.

An appropriate NTZ shall be established between close parallel final approach courses as described in paragraph 4.3 (see figure A3-1).

6.4 NOZ.

Appropriate NOZ's shall be established for each parallel final approach segment as described in paragraph 4.4 (see figure A3-1).

6.5 STAGGERED RUNWAY THRESHOLDS.

Where thresholds are staggered, the glide slope intercept point from the most distant runway approach threshold should not be more than 10 NM. It is recommended that the approach with the higher intercept altitude be the runway having the most distant approach threshold (from the point of view of an aircraft on approach).

6.6 LOCALIZER/AZIMUTH OFFSET.

Where an offset localizer is utilized, apply chapter 3 of this Volume. Where approach thresholds are staggered, the offset localizer course should be to the runway having the nearest approach threshold (from the point of view of an aircraft on approach). An offset requires a 50-foot increase in decision height

(DH) and is not authorized for Category II and III approaches. (Autopilots with autoland are programmed for localizers to be on runway centerline only.) The NTZ shall be established equidistant between final approach courses.

6.7 MONITOR ZONE.

This zone is a radar-monitored volume of airspace within which the PRM system automated alerts are active. The extent of the monitor zone is:

6.7.1 Monitor Zone Length. The PRM monitor zone begins where aircraft conducting simultaneous parallel approaches reach less than 1,000-foot vertical separation during final approach (typically at glide slope intercept for the higher altitude localizer intercept) and extends to 0.5 NM beyond the farthest DER, or the point where a 45° divergence occurs, whichever generates the greatest length for the monitor zone.

6.7.2 Monitor Zone Width. The PRM monitor zone (automated alerts) includes all of the area between the final approach courses and extends 0.5 NM outboard of each final approach course centerline.

6.7.3 Monitor Zone Height. The PRM monitor zone height may be defined in as many as five separate segments, each having an independent maximum height. Each segment covers the entire monitor zone width, and a portion of the monitor zone length. Within each segment, the monitor zone height extends from 50 feet above ground level to a minimum of 1,000 feet above the highest point within that segment of the glide slope, the runway surface, or the missed approach course, whichever attains the highest altitude.

7.0 MINIMUMS.

For close parallel procedures, only straight-in precision minimums apply.

8.0 MISSED APPROACH SEGMENT.

Volume 3 chapter 3 applies, except as stated in this appendix. Missed approach procedures for close parallels shall specify a turn as soon as possible after reaching a minimum of 400 feet above the touchdown zone, and diverge at a minimum of 45°. The turn points specified for the two parallel procedures should be established at the end of the straight segment minimum of 1.5 NM.

A 45° divergence shall be established by 0.5 NM past the most distant DER. Where an offset localizer is used, the first missed approach turn point shall be established so that the applicable flight track radius (table 5 in Volume 1, chapter 2), constructed in accordance with Volume 1, chapter 2, section 7, for the fastest category aircraft expected to utilize the offset course, shall not be less than 700 feet from the NTZ.

8.1 NTZ.

The NTZ shall be continued into the missed approach segment, as defined in paragraph 4.3 of this appendix (see figure A3-1).

8.2 NOZ.

The NOZ shall be continued into the missed approach segment, as defined in paragraph 4.4 of this appendix (see figure A3-1).

APPENDIX 4. OBSTACLE ASSESSMENT SURFACE EVALUATION FOR SIMULTANEOUS PARALLEL PRECISION OPERATIONS

1.0 BACKGROUND.

One of the major aviation issues is the steady increase in the number and duration of flight delays. Airports have not been able to expand to keep pace with traffic growth. The Federal Aviation Administration (FAA) has taken a variety of measures to increase airport capacity. These include revisions to air traffic control procedures; addition of landing systems, taxiways and runways; and application of new technology. The precision radar monitor (PRM) program is one of these new initiatives. PRM is an advanced radar monitoring system intended to increase the use of multiple, closely-spaced parallel runways in instrument meteorological conditions (IMC) weather by use of high resolution displays with alert algorithms and higher aircraft position update rate. Monitor controllers are required for both standard and closely-spaced runway separations. The primary purpose of radar monitoring during simultaneous, independent approach operations is to ensure safe separation of aircraft on the parallel approach courses. This separation may be compromised if an aircraft blunders off course toward an aircraft on the adjacent approach. For close parallel operations (3,400 feet but less than 4,300 feet) and for standard parallel operations (4,300 feet and above), the radar monitoring allows controllers to direct either aircraft off the approach course to avoid a possible collision. Resolution of a blunder is a sequence of events: the monitor alerts and displays the blunder, the controllers intervene, and the pilots comply with controller instructions; thus, increasing the operational safety, flyability, and airport capacity.

2.0 DEFINITIONS.

2.1 COURSE WIDTH (CW).

The angular course deviation required to produce a full scale (\pm) course deviation indication of the airborne navigation instrument. This width is normally tailored to a parameter of not greater than $\pm 3^\circ$. For precision runways longer than 4,000 feet, a linear sector width parameter of ± 350 feet each side of centerline at RWT applies. Few Category I localizers operate with a course sector width less than 3° ($\pm 1\frac{1}{2}^\circ$). Tailored width may be determined by the formula:

$$W = \text{ArcTan} \left(\frac{350}{D} \right) \text{ Total Course Width at RWT} = 2 \times W$$

Where: W = Half Width (in degrees) at RWT

D = Distance from localizer antenna to RWT (in feet)

2.2 PARALLEL APPROACH OBSTRUCTION ASSESSMENT (PAOA).

An examination of obstruction identification surfaces, in addition to the ILS TERPS surfaces, in the direction away from the NTZ and adjacent parallel ILS runway, into which an aircraft on an early ILS breakout could fly.

2.3 PARALLEL APPROACH OBSTRUCTION ASSESSMENT SURFACES (PAOAS).

PAOA assessment surfaces for identifying obstacles that may impact simultaneous precision operations.

2.4 PARALLEL APPROACH OBSTRUCTION ASSESSMENT SURFACE PENETRATION.

One or more obstructions that penetrate the PAOAS.

2.5 PARALLEL APPROACH OBSTRUCTION ASSESSMENT CONTROLLING OBSTRUCTION (PAOACO).

The obstruction within the boundaries of the PAOAS which constitutes the maximum penetration of that surface.

2.6 NO TRANSGRESSION ZONE (NTZ).

See Volume 3, appendix 3, paragraph 4.3.

2.7 NORMAL OPERATIONAL ZONE (NOZ).

See Volume 3, appendix 3, paragraph 4.4.

3.0 GENERAL.

This order characterizes criteria used during the interim test phase of evaluating close parallel operations where early turnout obstacle assessments were accomplished by contractual means using terrestrial photometric techniques combined with survey methods of surface evaluation. This assessment technique is recommended for future evaluations of all independent simultaneous parallel approach operations. Facility information (glidepath angle (GPA), threshold crossing heights (TCH), touchdown zone elevation (TDZE), threshold elevations, etc.) may be obtained from air traffic planning and automation, flight procedures offices, and/or the systems management organizations for the regions in which independent simultaneous parallel operations are planned.

3.1 PARALLEL RUNWAY SIMULTANEOUS ILS APPROACHES.

The procedures for airports with multiple parallel runways must ensure that an aircraft approach on one runway is safely separated from those approaching the adjacent parallel runway. An example of such procedures is depicted in figure A4-1. Aircraft are directed to the two intermediate segments at altitudes which differ by at least 1,000 feet. Vertical separation is required when lateral separation becomes less than 3 nautical miles (NM), as aircraft fly to intercept and stabilize on their respective localizers (LOC). This 1,000-foot vertical separation is maintained until aircraft begin descent on the glidepath. This 1,000-foot vertical separation is maintained until aircraft begin descent on the glidepath.

3.1.1 When lateral radar separation is less than the 3 NM and the 1,000-foot altitude buffer is lost, the aircraft must be monitored on radar. The controllers, on separate and discrete frequencies, will observe the parallel approaches, and if an aircraft blunders from the NOZ into a 2,000-foot NTZ, the monitor controller can intervene so that threatened aircraft on the adjacent approach are turned away in time to prevent a possible encounter. This maneuver, on the part of the threatened aircraft, is termed a "breakout" because the aircraft is directed out of the approach stream to avoid the transgressor aircraft. A controller for each runway is necessary so that one can turn the transgressing aircraft back to its course centerline while the other directs the breakout (see figure A4-1).

Figure A4-1. Simultaneous precision parallel Runway Approach Zones

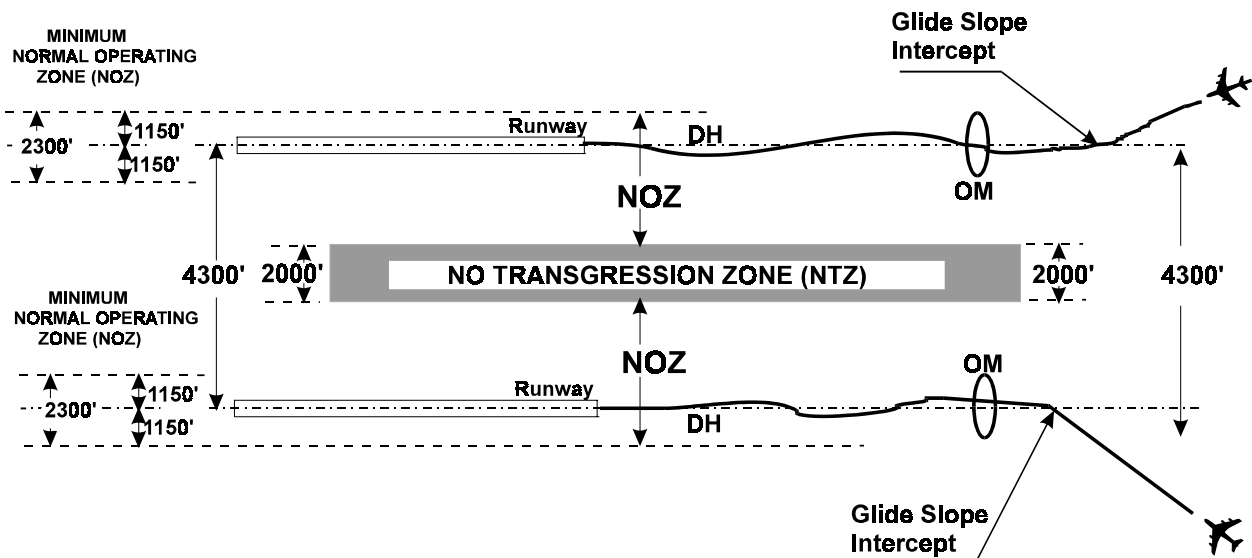

3.1.2 The 2,000-foot NTZ, flanked by two equal NOZ's, provides strong guidance to the monitor controller and maneuvering room for the aircraft to recover before entering the adjoining NOZ. Aircraft are required to operate on or near the approach course within the limits of the NOZ. If an aircraft strays into the NTZ or turns to a heading that will take it into the NTZ, it is deemed a threat to an aircraft on the adjacent course and appropriate corrective action or breakout instructions are issued (see figure A4-2).

Figure A4-2. Simultaneous ILS No Transgression Zone and Normal Operating Zone

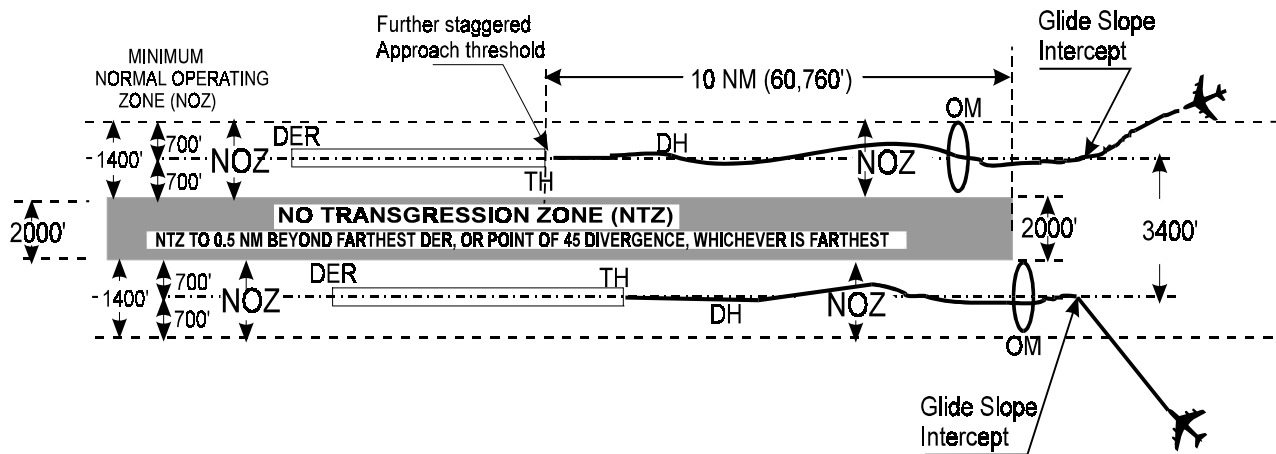

4.0 PAOA EVALUATION.

The PAOA evaluation shall be conducted to identify penetrating obstacles as part of a coordinated assessment for all independent simultaneous approach operations to parallel ILS/MLS runways. In these criteria, ILS glidepath/localizer terms are synonymous to and may be used interchangeably with MLS elevation glidepath/azimuth (GP/AZ) terms. The surface dimensions for the obstacle assessment evaluation are defined as follows:

4.1 SURFACE 1.

A final approach course descent surface which is coincident with the glide slope/glidepath (GS/GP) beginning at runway threshold with the width point abeam the threshold 350 feet from runway centerline opposite the NTZ, with lateral boundaries at the outer edge of the LOC/AZ CW, and ending at the farthest GS/GP intercept (see figure A4-3).

Figure A4-3. Final Approach Descent Surface 1

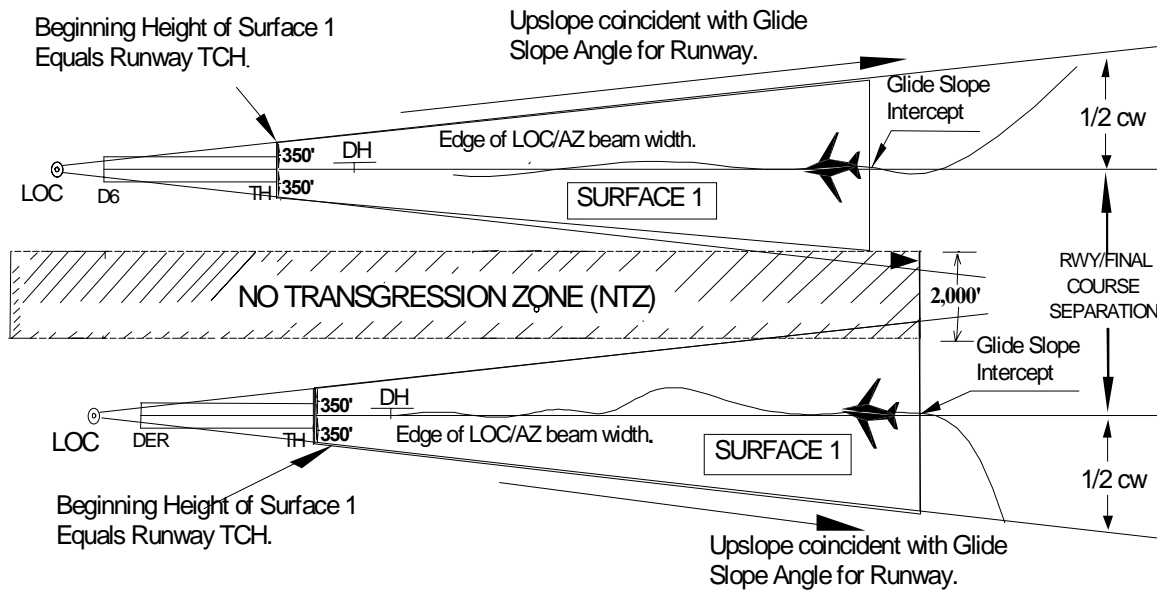

1/2 CW = Perpendicular distance from runway/extended C_L to edge of course beam width.

1/2 CW = Distance from Threshold in feet along C_L X TAN (1/2 Course Beam Angle) + 350'.
OR

1/2 CW = Distance from LOC/AZ Antenna in feet along C_L X TAN (LOC/AZ Beam Angle) / 2

Surface 1 Height – Distance from TH in feet along C_L X TAN of the GS/GP angle + TCH.

4.1.1 Length. Surface 1 begins over the runway threshold at a height equal to the TCH for the runway, and continues outward and upward at a slope that is coincident with the GS/GP, to its ending at the GS/GP intercept point.

4.1.2 Width. Surface 1 has a width equal to the lateral dimensions of the LOC/AZ course width. The Surface 1 half-width (see figure A4-2) is calculated using the following formula:

$$\frac{1}{2}W = A \times \tan\left(\frac{B}{2}\right) + 350$$

Where W = Width of Surface 1

A = Distance from RWT measured parallel to course

B = Course Width Beam Angle

OR

$$\frac{1}{2}W = L \times \tan\left(\frac{B}{2}\right)$$

Where W = Width of Surface 1

L = Distance from Azimuth antenna (in feet)

B = Course Width Beam Angle

4.1.3 Surface 1 Height. Surface height at any given centerline distance (d), may be determined in respect to threshold elevation, by adding the TCH to the product of centerline distance in feet from threshold times the tangent of the GS/GP angle.

$$h1 = [d \times \text{Tan}(GPA)] + TCH$$

Where: *h1* = surface 1 height above ASBL

4.2 SURFACE 2.

4.2.1 Length. Same as paragraph 4.1.1.

4.2.2 Width and Height. Surface 2 shares a common boundary with the outer edge of surface 1 on the side opposite the NTZ, and slopes upward and outward from the edge of the descent surface 1 at a slope of 11:1, measured perpendicular to the LOC/AZ extended course centerline. Further application is not required when the 11:1 surface reaches a height of 1,000 feet below the MVA, MSA, or MOCA, whichever is lowest (see figure A4-4).

Figure A4-4. Parallel Approach Obstacle Assessment Surface 2

Further application not required where the 11:1 Surface reaches a height of 1,000' below the MVA, MSA, or MOCA, whichever is lower.
The outer edge of Surface 2 may not typically be parallel to final course centerline.

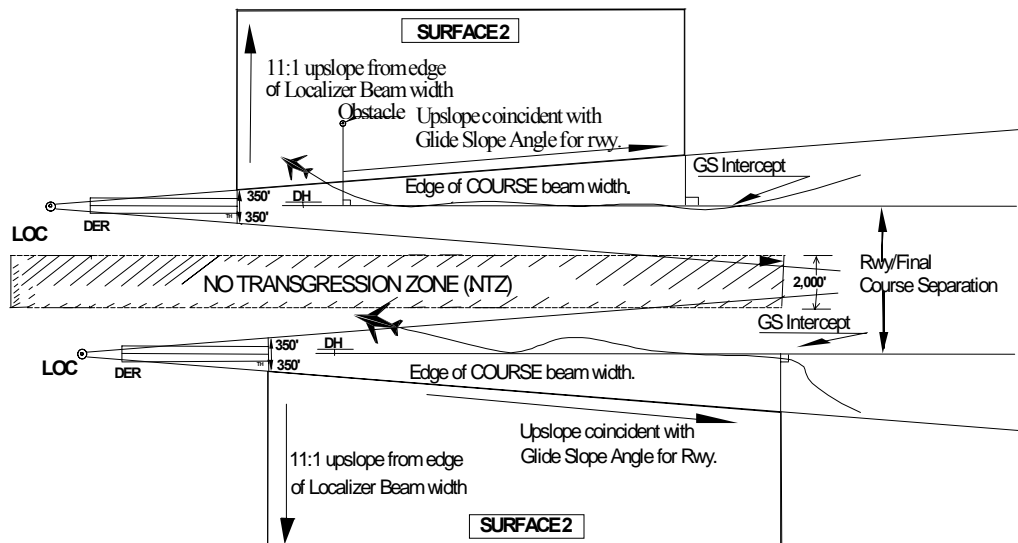

Further application not required where the 11:1 Surface reaches a height of 1,000' below the MVA, MSA, or MOCA, whichever is lowest.
Surface 2 Height = Surface 1 height + Height of 11:1 Slope measured from nearest edge of the LOC/AZ CW perpendicular to the course centerline.

4.3 SURFACE 3 (CATEGORY I).

4.3.1 Length. For category I operations, surface 3 begins at the point where surface 1 reaches a height of 200 feet above the TDZE and extends to the point the 40:1 and 11:1 slopes reach a height of 1,000 feet below the MVA, MSA, or MOCA, whichever is lowest.

4.3.2 Width. From the beginning point, the edge of surface 3 area splays at a 15° angle from a line parallel to the runway centerline.

4.3.3 Surface Height. Surface 3 begins at a height of 100 feet above TDZE (100 feet lower than surface 1). The surface rises longitudinally at a 40:1 slope along the 15° splay line CD while continuing laterally outward and upward at an 11:1 slope (line CE is perpendicular to the 15° splay line CD). Further application is not required when the 40:1 and 11:1 slopes reach a height of 1,000 feet below the MVA, MSA, or MOCA, whichever is lowest (see figure A4-5).

Figure A4-5. CAT I Missed Approach Early Breakout Parallel Approach Obstacle Assessment Surface 3.

The outer edges of Surfaces 2 or 3 may not typically be parallel to each other or runway C_L. Further application not required when the 40:1 and 11:1 surfaces reach a height of 1,000' below MVA, MSA or MOCA, whichever is lower.

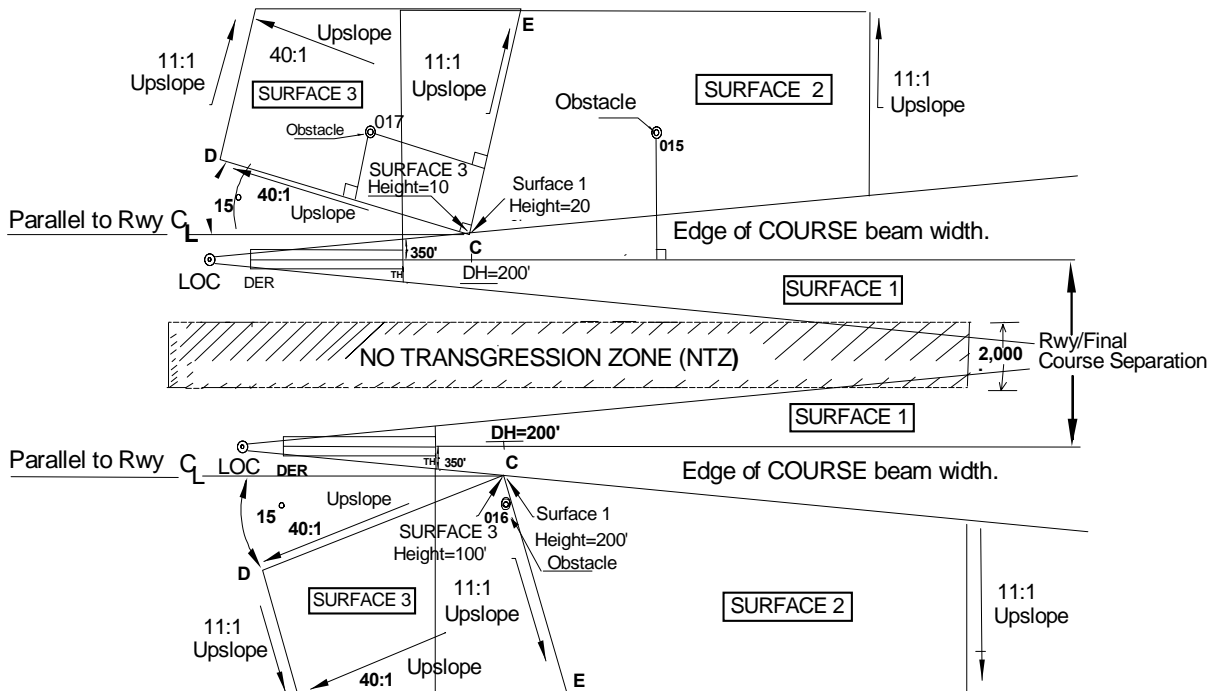

Further application not required when the 40:1 and 11:1 surfaces reach a height of 1,000' below MVA, MSA, or MOCA, whichever is lower. Surface 3 Height = Height of 11:1 Slope measured (fr. Obs.) perpendicular to Line CD + Height of 40:1 Slope measured (fr. Obs.) perpendicular to Line CE + 100 feet.

4.4 SURFACE 4 (CATEGORY II).

4.4.1 Length. Surface 4 begins at the point where surface 1 reaches a height of 100 feet above the runway TDZE and extends to the point 40:1 and 11:1 slopes reach a height of 1,000 feet below the MVA, MSA, or MOCA, whichever is lowest.

4.4.2 Width. From the point of beginning, the edge of surface 4 area splays at a 15° angle from a line parallel to the runway centerline.

4.4.3 Surface Height. Surface 4 begins at the point where surface 1 reaches a height of 100 feet above the runway TDZE and rises longitudinally at a 40:1 slope along the 15° splay line CD, while continuing laterally outward and upward at an 11:1 slope (line CE is perpendicular to the 15° splay line CD). Further application is not required when the 40:1 and 11:1 slopes reach a height of 1,000 feet below the MVA, MSA, or MOCA, whichever is lowest (see figure A4-6).

Figure A4-6. CAT II Missed Approach Early Breakout Parallel Approach Obstacle Assessment Surface 4

The outer edges of Surface 2 or 4 may not typically be parallel to each other or runway C_L .
Further application not required when the 40:1 and 11:1 surfaces reach a height of 1,000' below MVA, MSA, or MOCA, whichever is lower.

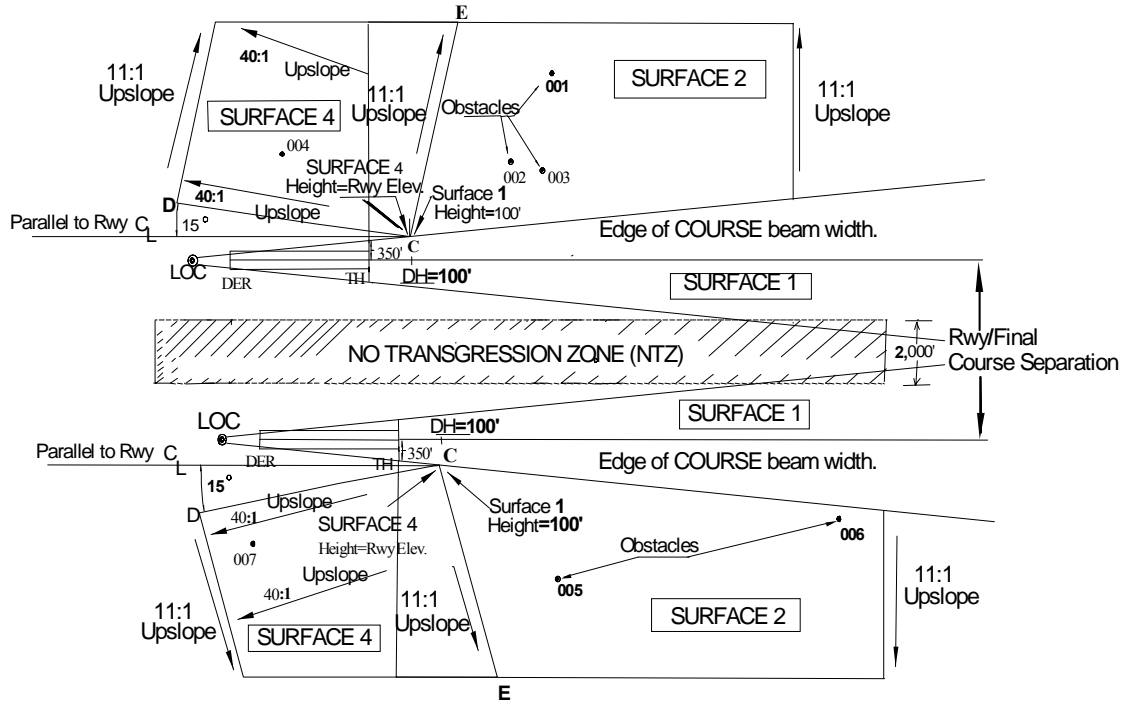

Further application not required when the 40:1 and 11:1 surfaces reach a height of 1,000' below MVA, MSA, or MOCA, whichever is lower. Surface 4 Height = Height of 11:1 Slope measured (fr. Obs.) perpendicular to Line CD + Height of 40:1 Slope measured (fr. Obs.) perpendicular to Line CE.

4.5 ESTABLISH A LATITUDE-LONGITUDE LIST for all obstacles penetrating PAOA surfaces 2, 3, and 4. Identify locations of surface penetration within the surface areas (see figures A4-3, A4-4, and A4-5).

4.6 PARALLEL OPERATIONS APPLICATION REQUIREMENTS.

PAOA obstacle penetrations shall be identified and, through coordinated actions of those affected, considered for electronic mapping on controller radar displays. If possible, penetrations should be removed by facilities considering independent simultaneous approach operations to parallel precision runways. Where

obstacle removal is not feasible, air traffic operational rules shall be established to avoid obstacles. If a significant number of penetrations occur, a risk assessment study shall be required to provide guidance as to whether independent simultaneous ILS/MLS operations to parallel runways should be approved or denied.

THIS PAGE INTENTIONALLY LEFT BLANK

APPENDIX 5.
THRESHOLD CROSSING HEIGHT
GROUND POINT OF INTERCEPT
RUNWAY POINT OF INTERCEPT
TCH/GPI/RPI CALCULATION

The following spreadsheets are a part of this appendix and can be found on the internet "<http://terps.faa.gov>"

Figure A5-1. Non-Radar Precision TCH/GPI/RPI

Figure A5-2. Precision Approach Radar (PAR) (Scanning Radar)

Figure A5-3. Precision Radar TCH/GPI/RPI

THIS PAGE INTENTIONALLY LEFT BLANK

Version 1.0

Figure A5-1. Non-Radar Precision TCH/GPI/RPI

1,016.00	A=Distance (ft) from GS antenna to RWT
100.00	a=RWT elevation (MSL)
98.00	c=Elevation (MSL) of runway crown at RPI/TDP
90.00	h=ILS antenna base elevation (MSL)
107.20	p=Phase center (MSL) of elevation antenna
3.00	e=Glidepath angle

STEP 1: CALCULATE OR SPECIFY TCH

51.25 ILS (smooth terrain) $\tan(e) \times A - (a - c)$

43.25 ILS (rapidly dropping terrain) $\tan(e) \times A - (a - h)$

60.45 MLS $\tan(e) \times A + (p - a)$

50.00 LAAS/WAAS Specify TCH

STEP 2: CALCULATE GPI

977.84 ILS (smooth terrain)

825.19 ILS (rapidly dropping terrain) $\frac{TCH}{\tan(e)}$

1,153.38 MLS

954.06 LAAS/WAAS

STEP 3: CALCULATE RPI

1,016.00 ILS (smooth terrain)

863.35 ILS (rapidly dropping terrain) $\frac{TCH + (a - c)}{\tan(e)}$

1,191.55 MLS

992.22 LAAS/WAAS

**Figure A5-2.
Precision Approach Radar (PAR)
(Scanning Radar)**

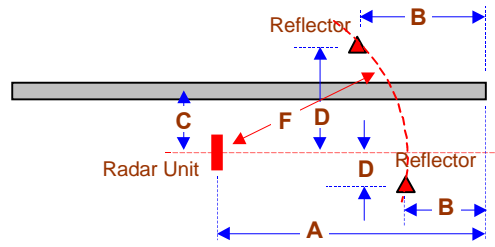

Version 1.0

ELEVATIONS (MSL):		DISTANCES (FT):	
Threshold [a]:	100	AZ antenna to threshold [A]:	4500
Touchdown Reflector [b]:	105	TD reflector to threshold [B]:	750
RWY Crown in TDZE [c]:	100.7	AZ antenna to centerline [C]:	450
RPI (if known) [d]:	100.5	TD reflector to CLA line [D]:	475
Glidepath Angle [e]:	3	RWY gradient (if required) [E]:	0.00023333

STEP 1: Determine distance from AZ antenna to TD reflector [F].

3,779.96 $F = \sqrt{(A-B)^2 + D^2}$

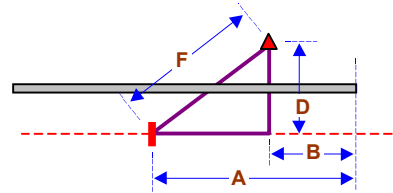

STEP 2: Determine threshold crossing height [TCH].

44.14 $TCH = \tan(e) \times (A - \sqrt{F^2 - C^2}) + (b - a)$

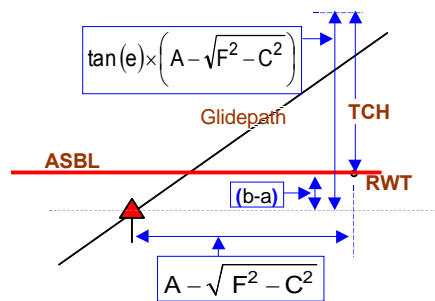
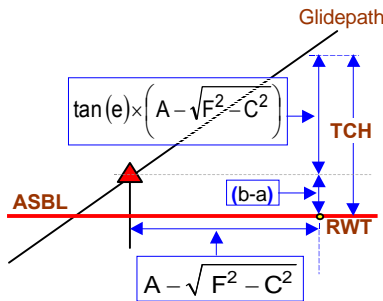

STEP 3: Determine ground point of intercept [GPI].

842.32 $GPI = \frac{TCH}{\tan(e)}$

STEP 4: Determine runway point of intercept [RPI].

[d] known
832.78 $RPI = \frac{TCH - (d - a)}{\tan(e)}$

[d] unknown
838.59 $RPI = \frac{TCH}{\tan(e) + E}$ for up sloping runway

[d] unknown
846.09 $RPI = \frac{TCH}{\tan(e) - E}$ for down sloping runway

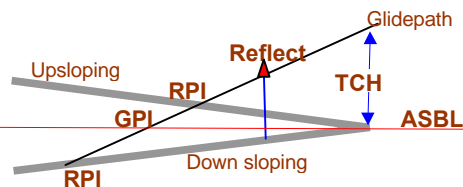

Version 1.0

Figure A5-3. Precision Radar TCH/GPI/RPI (Tracking Radar)

100.00	a=RWT elevation (MSL)
98.00	c=Elevation (MSL) of runway crown at RPI/TDP
3.00	e=Glidepath angle

STEP 1: SPECIFY TCH

50.00 <== TCH

STEP 2: CALCULATE GPI

954.06 <== GPI $\frac{\text{TCH}}{\tan(e)}$

STEP 3: CALCULATE RPI

992.22 <== RPI $\frac{\text{TCH} + (a - c)}{\tan(e)}$

THIS PAGE INTENTIONALLY LEFT BLANK

FAA ORDER

8260.3B

Army
Navy
Coast Guard
Air Force

TM 95-226
OPNAV Inst. 3722.16C
CG 318
AFMAN 11-226(I)

**UNITED STATES STANDARD
FOR
TERMINAL
INSTRUMENT
PROCEDURES
(TERPS)**



Policy Memo
Dec 28 2007

VOLUME 4

**DEPARTURE PROCEDURE
CONSTRUCTION**

**U. S. DEPARTMENT OF TRANSPORTATION
FEDERAL AVIATION ADMINISTRATION**

VOLUME 4. TABLE OF CONTENTS

DEPARTURE PROCEDURE CONSTRUCTION

	Page
CHAPTER 1. GENERAL CRITERIA	
1.0 General -----	1-1
1.1 Terminology, Abbreviations, and Definitions -----	1-1
1.1.1 Climb Gradient (CG) -----	1-1
1.1.2 Course -----	1-1
1.1.3 Dead Reckoning (DR) -----	1-1
1.1.4 Departure End of Runway (DER) -----	1-1
1.1.5 Departure Reference Line (DRL) -----	1-1
1.1.6 Departure Reference Point (DRP) -----	1-1
1.1.7 Departure Route -----	1-2
1.1.8 Departure Sector -----	1-2
1.1.9 Diverse Vector Area (DVA) -----	1-2
1.1.10 Diverse Departure -----	1-2
1.1.11 Diverse Departure Evaluation to Establish Sector(s) for Prescribed Departure Routes -----	1-2
1.1.12 Initial Climb Area (ICA) -----	1-2
1.1.13 ICA Baseline (ICAB) -----	1-3
1.1.14 ICA End-Line (ICAE) -----	1-3
1.1.15 Instrument Flight Rules (IFR) -----	1-3
1.1.16 Instrument Meteorological Conditions (IMC) -----	1-3
1.1.17 Obstacle -----	1-3
1.1.18 Obstacle Clearance Surface (OCS) -----	1-3
1.1.19 Obstruction Evaluation Area (OEA) -----	1-3
1.1.20 Positive Course Guidance (PCG) -----	1-3
1.1.21 Required Obstacle Clearance (ROC) -----	1-3
1.1.22 Standard Climb Gradient (SCG) -----	1-3
1.1.23 Start End of Runway (SER) -----	1-4
1.1.24 Takeoff Runway Available (TORA) -----	1-4
1.1.25 Visual Flight Rules (VFR) -----	1-4
1.1.26 Visual Meteorological Conditions (VMC) -----	1-4
1.1.27 Visual Climb Area (VCA) -----	1-4
1.1.28 Visual Climb over Airport (VCOA) -----	1-4
1.2 Departure Criteria Application -----	1-4
1.2.1 Perform a Diverse Departure Evaluation -----	1-4
1.2.2 Develop Departure Routes -----	1-4
1.2.3 Develop a VCOA Procedure -----	1-5
1.2.4 At Locations Served by Terminal Radar -----	1-5
1.3 Departure OCS Application -----	1-5
1.3.1 Low, Close-in OCS Penetrations -----	1-5
1.3.2 Calculating OCS Height -----	1-5
1.4 Climb Gradients -----	1-6
1.4.1 Calculating Climb Gradients to Clear Obstacles -----	1-6
1.4.2 Calculating the CG Termination Altitude -----	1-7
1.4.3 Climb Gradients to Altitudes for other than Obstacles, i.e., ATC -----	1-7

VOLUME 4. TABLE OF CONTENTS (Continued)

		Page
1.4.4	Multiple Climb Gradients Application -----	1-7
1.4.5	Limiting TORA to Reduce Climb Gradient-----	1-8
1.4.6	Effect of DER-to-Obstacle Distance-----	1-8
1.5	Ceiling and Visibility -----	1-9
1.5.1	Ceiling-----	1-9
1.5.2	Visibility-----	1-9
1.6	Initial Climb Area (ICA) -----	1-9
1.6.1	ICA Terms -----	1-9
1.6.2	Area -----	1-9
CHAPTER 2.	DIVERSE DEPARTURE	
2.0	General-----	2-1
2.1	Area -----	2-1
2.1.1	Initial Climb Area -----	2-1
2.1.2	Diverse "A" Area -----	2-2
2.1.3	Diverse "B" Area -----	2-2
2.2	Departure Sectors -----	2-3
2.2.1	Boundary Based on the ICA -----	2-3
2.2.2	Defining Sector Boundaries -----	2-4
2.2.3	Sector Limitations-----	2-5
2.3	DVA Evaluation (ASR Required)-----	2-6
2.3.1	ICA-----	2-6
2.3.2	DVA "A" and "B" Areas -----	2-6
CHAPTER 3.	DEPARTURE ROUTES	
3.0	Straight Route Departure Segments -----	3-1
3.1	Dead Reckoning (DR) Departure -----	3-1
3.2	Positive Course Guidance (PCG) Departure, 15° or Less-----	3-2
3.3	Localizer Guidance -----	3-2
3.3.1	NDB Guidance-----	3-3
3.3.2	VOR/TACAN Guidance -----	3-3
3.3.3	Secondary Area Obstructions -----	3-4
3.4	RESERVED -----	3-4
3.5	Turning Segment Construction -----	3-5
3.5.1	General -----	3-5
3.6	RESERVED -----	3-6
3.7	Turn to PCG-----	3-6
3.7.1	Extend the ICA Boundaries -----	3-6
3.7.2	Specify a Course-----	3-6
3.8	Multiple Turns-----	3-8
3.8.1	Climb to Altitude and Turn; Turns less than 90° -----	3-8
3.8.2	Climb to Intercept a Course -----	3-10
3.8.3	Figure 3-10 Illustrates Multiple Turns more than 90° -----	3-11

VOLUME 4. TABLE OF CONTENTS (Continued)

	Page
3.8.4 Figure 3-11 Illustrates Multiple Turns more than 90° -----	3-13
3.8.5 Figure 3-12 Illustrates the 2-Mile Lead -----	3-15
3.8.6 Evaluation of Multiple Turn Areas -----	3-15
CHAPTER 4. VISUAL CLIMB OVER AIRPORT (VCOA)	
4.0 General -----	4-1
4.1 Basic Area -----	4-1
4.2 VCOA Evaluation -----	4-2
4.2.1 Diverse VCOA -----	4-2
4.2.2 Departure Routes -----	4-3
4.2.3 Published Annotations -----	4-4
4.3 Ceiling and Visibility -----	4-5

THIS PAGE INTENTIONALLY LEFT BLANK

CHAPTER 1. GENERAL CRITERIA

1.0 GENERAL.

IFR departure procedures may be designed and published for all runways authorized by the approving authority. For civil procedures, runway/taxiway separations, and airport obstacle free zones (OFZ) must meet the standards in Advisory Circular (AC) 150/5300-13, Airport Design, or appropriate military directives for military procedures for specified departure visibility minimums. Criteria for RNAV-equipped aircraft are provided in Orders 8260.44, Civil Utilization of Area Navigation (RNAV) Departure Procedures, and 8260.40, Flight Management System (FMS) Instrument Procedures Development.

1.1 TERMINOLOGY, ABBREVIATIONS, AND DEFINITIONS.

1.1.1 Climb Gradient (CG).

A climb requirement expressed in ft/NM (gradient greater than 200 ft/NM).

1.1.2 Course.

A specified track measured in degrees from magnetic north.

1.1.3 Dead Reckoning (DR).

The navigation of an airplane solely by means of computations based on airspeed, course, heading, wind direction, speed, ground speed, and elapsed time.

1.1.4 Departure End of Runway (DER).

The end of the runway opposite the landing threshold. It is sometimes referred to as the stop end of runway (SER).

1.1.5 Departure Reference Line (DRL).

An imaginary line of indefinite length perpendicular to runway centerline at the DRP.

1.1.6 Departure Reference Point (DRP).

A point on the runway centerline 2,000 feet from the SER (see figure 1-1).

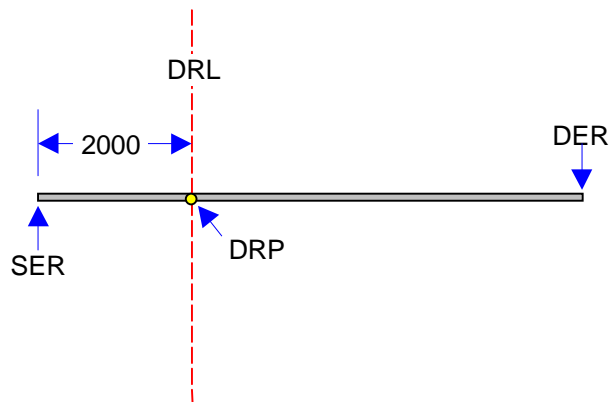
Figure 1-1. Runway Terms**1.1.7 Departure Route.**

A specified course and altitude along a track defined by positive course guidance (PCG) to a clearance limit, fix, or altitude.

1.1.8 Departure Sector.

Airspace defined by a heading or a range of headings for aircraft departure operations.

1.1.9 Diverse Vector Area (DVA).

An area in which a prescribed departure route is not required. Radar vectors may be issued below the minimum vectoring or minimum IFR altitude. It can be established for diverse departure, departure sectors, and/or video map radar areas portraying obstacles and terrain.

1.1.10 Diverse Departure.

A departure without restrictions to the route of flight.

1.1.11 Diverse Departure Evaluation to Establish Sector(s) for Prescribed Departure Routes.

An evaluation of a diverse area to establish an unrestricted area or sector for purposes of publishing departure routes, including multi-turns and legs.

1.1.12 Initial Climb Area (ICA).

An area beginning at the DER to provide unrestricted climb to at least 400 feet above DER elevation.

1.1.13 ICA Baseline (ICAB).

A line at DER, perpendicular to runway centerline, denoting the beginning of the ICA.

1.1.14 ICA End-Line (ICAE). A line at end of ICA perpendicular to the departure course.**1.1.15 Instrument Flight Rules (IFR).**

Rules governing the conduct of flight under instrument meteorological conditions.

1.1.16 Instrument Meteorological Conditions (IMC).

Meteorological conditions expressed in terms of visibility, distance from clouds, and ceiling less than the minima specified for visual meteorological conditions.

1.1.17 Obstacle.

TIL99-003 Synonymous with natural or man-made obstacles, obstructions, or obstructing terrain.

1.1.18 Obstacle Clearance Surface (OCS).

An inclined surface associated with a defined area for obstacle evaluation.

1.1.19 Obstruction Evaluation Area (OEA).

Areas requiring obstacle evaluation.

1.1.20 Positive Course Guidance (PCG).

A continuous display of navigational data, which enables an aircraft to be flown along a specific course, e.g., radar vector, RNAV, ground-based NAVAID's.

1.1.21 Required Obstacle Clearance (ROC).

Required vertical clearance expressed in feet between an aircraft and an obstruction.

1.1.22 Standard Climb Gradient (SCG).

Departure and missed approach obstacle clearance is based on the assumption that an aircraft will climb at a gradient of at least 200 feet per NM. This is the standard climb gradient.

1.1.23 Start End of Runway (SER).

The beginning of the takeoff runway available.

1.1.24 Takeoff Runway Available (TORA).

The length of runway declared available and suitable for satisfactory takeoff run requirements.

1.1.25 Visual Flight Rules (VFR).

Rules that govern the procedures for conducting flight under visual conditions.

1.1.26 Visual Meteorological Conditions (VMC).

Meteorological conditions expressed in terms of visibility, distance from clouds, and ceiling equal to or better than specified minima.

1.1.27 Visual Climb Area (VCA).

Areas around the airport reference point (ARP) to develop a VCOA procedure.

1.1.28 Visual Climb over Airport (VCOA).

Option to allow an aircraft to climb over the airport with visual reference to obstacles to attain a suitable altitude from which to proceed with an IFR departure.

1.2 DEPARTURE CRITERIA APPLICATION.

Evaluate runways for IFR departure operations by applying criteria in the sequence listed below (paragraphs 1.2.1 through 1.2.3).

1.2.1 Perform a diverse departure evaluation to each runway authorized for IFR takeoff. Diverse departure is authorized if the appropriate OCS is clear. If the OCS is penetrated, consider development of departure sectors and/or climb gradients.

1.2.2 Develop departure routes where obstacles prevent diverse departure operations.

Memo

1.2.3 **Develop a VCOA procedure** where obstacles more than 3 statute miles from DER require climb gradients greater than 200 ft/NM (see chapter 4).

1.2.4 **At locations served by terminal radar**, air traffic control may request development of diverse vector areas to aid in radar vectoring departure traffic (see chapter 2, paragraph 2.3).

1.3 DEPARTURE OCS APPLICATION.

Policy Memo
Mar 17 2005

The OCS begins at the DER at DER elevation. EXCEPTION: Adjust the origin height up to 35 feet above DER as necessary to clear existing obstacles (see figure 1-2). Evaluate proposed obstacles assuming the OCS origin is at DER elevation.

Figure 1-2. OCS Starting Elevation

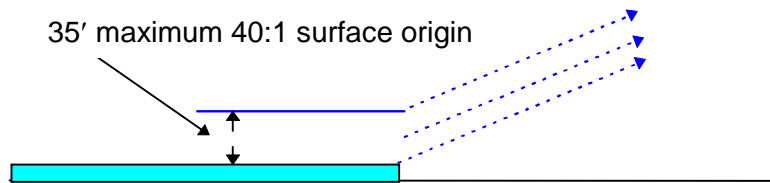

1.3.1 Low, Close-In OCS Penetrations.

Policy Memo
Nov 16 2010

Do not publish a CG to a height of 200 feet or less above the DER elevation. Annotate the location and height of any obstacles that cause such climb gradients.

1.3.2 Calculating OCS Height.

The OCS height is based on the distance measured from the OCS origin along the shortest distance to an obstacle within the segment.

1.3.2 a. Primary Area. The OCS slope is 40:1. Use the following formula to calculate the OCS height:

$$h_{OCS} = \frac{d}{40} + e$$

where d=shortest distance (ft) from the OCS origin to the obstacle
e=OCS origin elevation

Example: $\frac{8923}{40} + 1221 = 1444.08 \text{ ft}$

- 1.3.2 b. Secondary Area.** (Applicable only when PCG is identified.) The OCS slope is 12:1. The secondary OCS elevation is the sum of the 40:1 OCS rise (a) in the primary area to a point the obstacle is perpendicular to the departure course, and the secondary OCS rise (b) from the edge of the primary OCS to the obstacle (see figure 1-3).

Figure 1-3. Secondary OCS

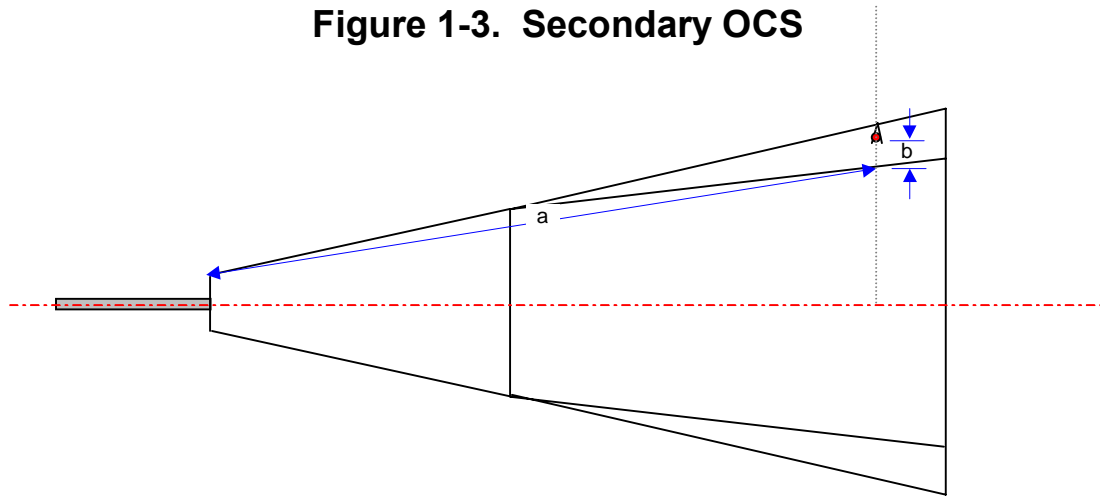

$$h_{\text{SECONDARY}} = \frac{a}{40} + \frac{b}{12}$$

Example: $\frac{21191}{40} + \frac{318}{12} = 556.28$

1.4 CLIMB GRADIENTS.

Departure procedure obstacle clearance is based on a minimum climb gradient performance of 200 ft/NM (see figure 1-4).

Figure 1-4. Standard Climb Gradient

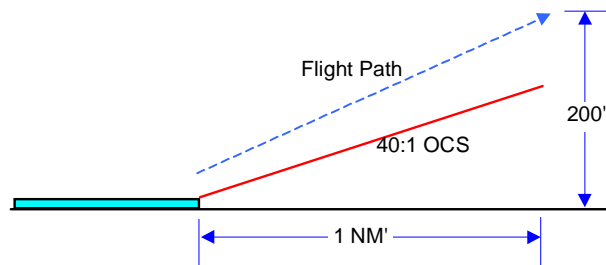

1.4.1 Calculating Climb Gradients to Clear Obstacles.

Climb gradients in excess of 500 ft/NM require approval of the Flight Standards Service or the appropriate military authority. Calculate climb gradients using the following formula::

Standard Formula

$$CG = \frac{O - E}{0.76 D}$$

DoD Option*

$$CG = \frac{(48D + O) - E}{D}$$

where O = obstacle MSL elevation

E = climb gradient starting MSL elevation

D = distance (NM) from DER to the obstacle

Examples:

$$\frac{2049 - 1221}{0.76 \times 3.1} = 351.44$$

Round to 352 ft/NM

$$\frac{(48 \times 3.1 + 2049) - 1221}{3.1} = 315.10$$

Round to 316 ft/NM

* For use by military aircraft only. Not for civil use.

1.4.2 Calculating the CG Termination Altitude.

When the aircraft achieves an altitude that provides the required obstacle clearance, the CG restriction may be lifted. This altitude is called the "climb to" altitude (A). Calculate the climb-to altitude using the following formula:

$$A = E + (CG \times D)$$

$$\text{Example: } 1221 + (352 \times 3.1) = 2312.20 \text{ Round to } 2400$$

1.4.3 Climb Gradients to Altitudes for Other than Obstacles, i.e., ATC.

Calculate the climb gradient to the stated "climb to" altitude using the following formula where (D) is the distance from the beginning of the climb to the point where the altitude is required:

$$CG = \frac{A - E}{D}$$

$$\text{Example: } \frac{3000 - 1221}{5} = 355.8 \text{ round to } 356 \text{ ft/NM}$$

NOTE: The climb gradient must be equal to or greater than the gradient required for obstacles along the route of flight.

1.4.4 Multiple Climb Gradients Application.

Do not publish a number of different gradients for a series of segments. Consider only one climb gradient, which is the most efficient gradient to represent the entire length of the climb gradient distance that encompasses all of the climb gradients required.

1.4.5 Limiting TORA to Reduce Climb Gradient.

Limiting the available length of the departure runway during takeoff is an option that can be used to reduce departure climb gradients. Use of this option requires approval of FAA Flight Standards or the appropriate military authority. Use the following formula to determine the TORA for a given desired climb gradient (DCG):

$$\text{TORA} = L - \left(\frac{A}{\text{DCG}} - \frac{A}{\text{CG}} \right) 6076.11548$$

Where A=Altitude above DER elevation where CG ends

CG=Required climb gradient before adjustments

DCG=Desired climb gradient

L=Full length of runway available for departure
before adjustments

$$\text{Example: } 10000 - \left(\frac{1000}{250} - \frac{1000}{300} \right) 6076.11548 = 5949.26'$$

1.4.6 Effect of DER-To-Obstacle Distance.

1.4.6 a. **Where obstacles 3 statute miles or less** from the DER penetrate the OCS:

1.4.6 a. **(1) Publish** a note identifying the obstacle(s) type, location relative to DER, AGL height, and MSL elevation, and

1.4.6 a. **(2) Publish** standard takeoff minimums with a required CG to a specified altitude, and

1.4.6 a. **(3) Publish** a ceiling and visibility to see and avoid the obstacle(s), and/or

1.4.6 a. **(4) Develop** a specific textual or graphic route to avoid the obstacle(s).

NOTE: Where low, close-in obstacles result in a climb gradient to an altitude 200 feet or less above DER elevation, only paragraph 1.4.6a(1) applies.

1.4.6 b. **Where obstacles more than 3 statute miles** from the DER penetrate the OCS:

1.4.6 b. **(1) Publish** standard takeoff minimums with a required CG to a specified altitude, and

1.4.6 **b. (2) Develop** a VCOA procedure to an altitude that will provide obstacle clearance without a CG, and/or

1.4.6 **b. (3) Develop** a specific textual or graphic departure route to avoid the obstacle(s).

1.5 **CEILING AND VISIBILITY.**

1.5.1 **Ceiling.**

Specify a ceiling value equal to the height of the obstruction above the airport elevation rounded to the next higher 100-foot increment.

1.5.2 **Visibility.**

Specify a visibility value equal to the distance measured directly from the DER to the obstruction rounded to the next higher reportable value. Limit the visibility to a distance of 3 statute miles.

1.6 **INITIAL CLIMB AREA (ICA).**

The ICA is an area centered on the runway centerline extended used to evaluate obstacle clearance during the climb to 400 feet above DER (minimum climb gradient 200 ft/NM).

1.6.1 **ICA Terms.**

1.6.1 **a. ICA baseline (ICAB).** The ICAB is a line extending perpendicular to the runway centerline ± 500 at DER. It is the origin of the ICA (see figure 1-5).

1.6.1 **b. ICA end-line (ICAE).** The ICAE is a line at the end of the ICA perpendicular to the runway centerline extended. The splay of 15° and length of the ICA determine its width (see figure 1-5).

1.6.2 **Area.**

1.6.2 **a. Length.** The ICA length is normally 2 NM, measured from the ICAB to the ICAE along runway centerline extended. It may be less than 2 NM in length for early turns by publishing a climb gradient, or a combination of climb gradient and reduction in TORA. The ICA may be extended beyond 2 NM to maximum length of 10 NM. A specified altitude (typically 400' above DER) or the interception of PCG route must identify the ICAE.

- 1.6.2 b. Width.** The ICA origin is 1,000 feet (± 500 perpendicular to runway centerline) wide at the DER. The area splays outward at a rate of 15° relative to the departure course (normally runway centerline).

Figure 1-5. ICA

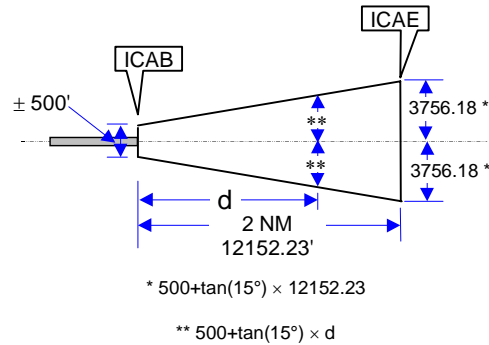

- 1.6.2 c. OCS.** The OCS originates at the ICAB, normally at DER elevation (see paragraph 1.3). Apply the OCS by measuring the shortest distance from the ICAB to the obstacle and evaluate per paragraph 1.3. The MSL elevation of the ICAE is calculated using the following formula:

$$\text{MSL ICAE elevation} = a + b + 303.81$$

where a=DER elevation
 b=OCS origin height above DER elevation
 (nominally 0)

Example: $\text{ICAE elevation} = 987.24 + 0 + 303.81 = 1291.05$

CHAPTER 2. DIVERSE DEPARTURE

2.0 GENERAL.

Evaluate diverse "A" and "B" areas to a distance of 25 NM for nonmountainous areas (see figure 2-1) and 46 NM for mountainous areas. If obstacles do not penetrate the OCS, unrestricted diverse departure may be authorized; publish standard takeoff minimums.

2.1 AREA. The diverse departure evaluation covers three areas:

Initial Climb Area. See chapter 1, paragraph 1.6.

Diverse A. All areas on the DER side of the DRL.

Diverse B. All areas on the SER side of the DRL.

Figure 2-1. Diverse "A" and "B" Areas

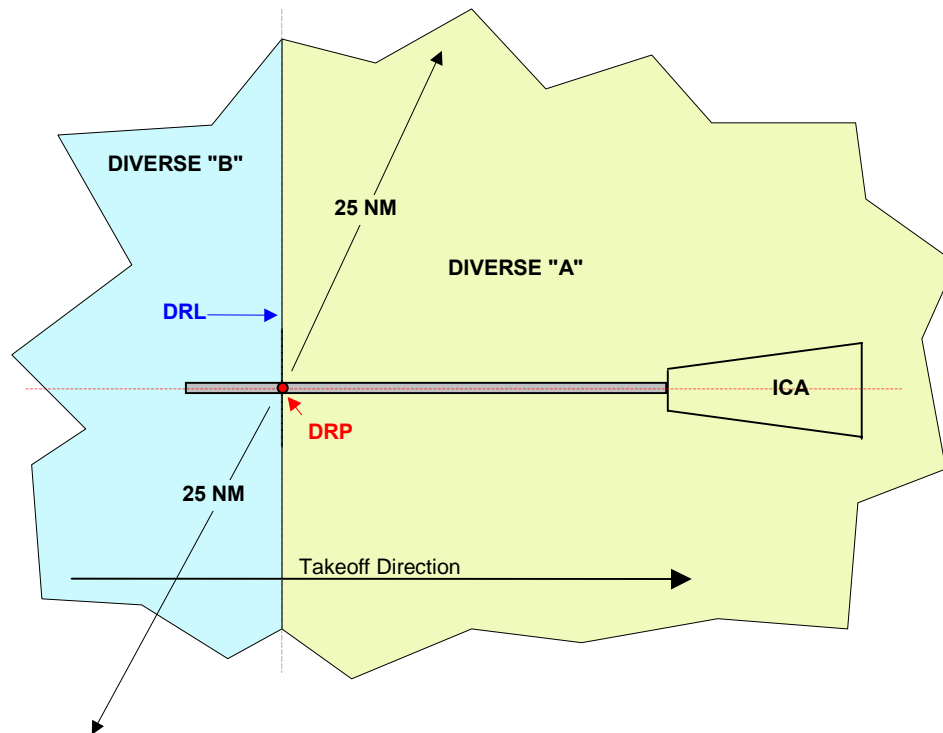

2.1.1 Initial Climb Area (ICA).

Evaluate the ICA under paragraph 1.6.

2.1.2 Diverse "A" Area.

Calculate the height of the OCS at any given location in the diverse "A" area by measuring the distance from the obstacle to the closest point on the centerline of the runway between the DRP and DER, or the closest point on ICA boundary lines as appropriate (see figure 2-2). The beginning OCS elevation is equal to the MSL elevation of the ICAE.

$$h = a + \frac{d}{40}$$

where h=OCS MSL elevation at obstacle

d=distance (ft) from obstacle to closest point

a=ICAE MSL elevation

Example: $h = 1309.77 + \frac{18002.33}{40} = 1759.83$

Figure 2-2. Diverse "A" Area Evaluation

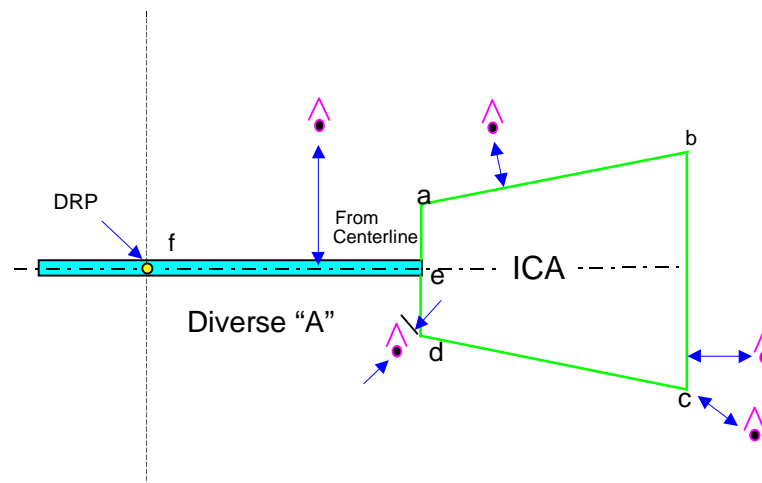

2.1.3 Diverse "B" Area.

Evaluate obstacles in the Diverse "B" area by measuring the distance in feet from the obstacle to the DRP (see figure 2-3). Calculate the OCS MSL elevation at the obstacle using the following formula:

$$h = \frac{d}{40} + (b + 400)$$

where h=OCS MSL elevation at obstacle

d=distance (ft) from obstacle to DRP

b=Airport MSL elevation

Example: $h = \frac{8500}{40} + (1283.22 + 400) = 1895.72$

Figure 2-3. Diverse "B" Area

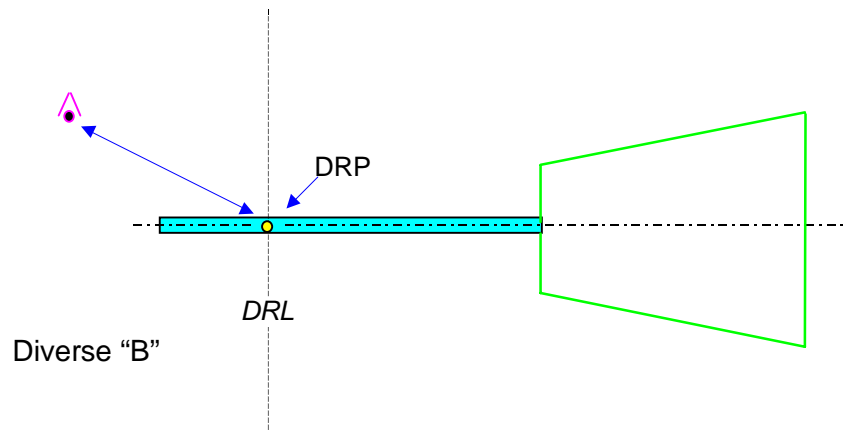

2.2 DEPARTURE SECTORS.

Where OCS penetrations prevent unrestricted diverse departure, consider constructing sectors within the diverse areas where departure flight is prohibited. Departure instructions must assure the aircraft will maneuver clear of the prohibited sector boundaries. Separate sector boundaries from obstacles via a buffer established by the 20° splay from the DRP. The minimum angle between sector boundaries is 30°. The ICA must be protected at all times (see figure 2-4).

Figure 2-4. Minimum Sector Area

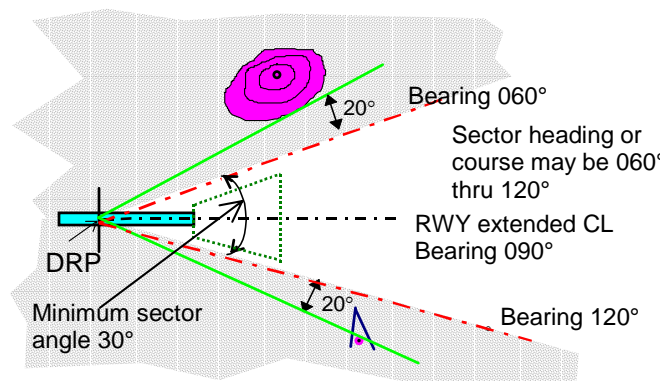

2.2.1 Boundary Based on the ICA.

When the 20° splay from the DRP cuts across the ICA, construct a line 20° relative to the side of the ICA. To protect the ICA, no obstacle may lie inside this line (see figure 2-5).

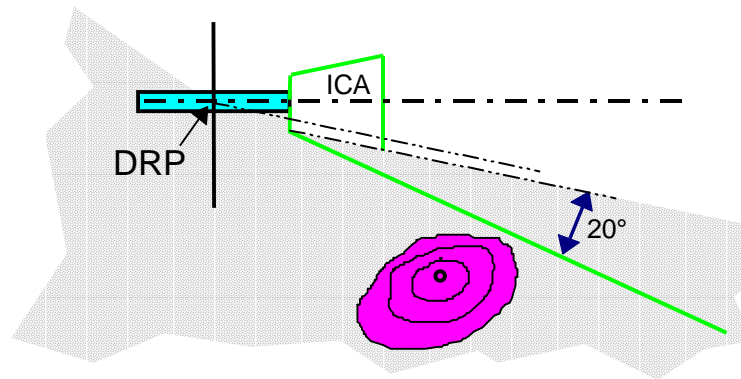
Figure 2-5. Boundary Based on ICA

- 2.2.1 a. Outer Boundary involving a Turn.** Locate the turn point on runway centerline (extended) and establish the ICAE. Construct the outer boundary from the ICAE, using table 1-1 for selection of the outer boundary radius. Construct a line from the obstacle tangent to the outer boundary radius. Establish the outer boundary buffer 20° from this line on the maneuvering side. Begin the 20° buffer at the tangent point where the obstacle line intercepts the arc (see figure 2-6).

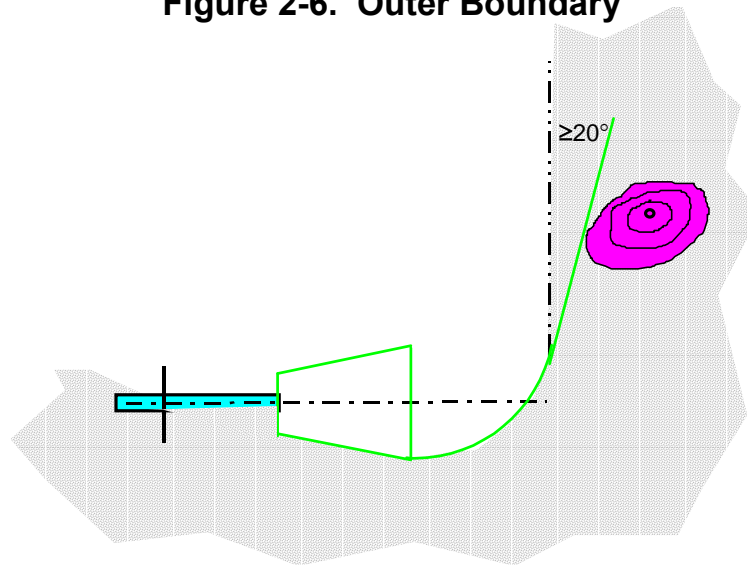
Figure 2-6. Outer Boundary

2.2.2 Defining Sector Boundaries.

Construct boundaries to define each sector. Sector boundaries originate at the DRP, or are defined tangentially from the outer boundary radius (see figure 2-7A). Define and publish sector boundaries by reference to aircraft magnetic headings. Sector "headings" shall be equivalent to the magnetic bearing of the sector boundaries from their origins.

2.2.3 Sector Limitations.

- 2.2.3 a. The maximum turn** from the takeoff runway in any one direction is 180° relative to takeoff runway heading.

Figure 2-7A. Sector Limitations

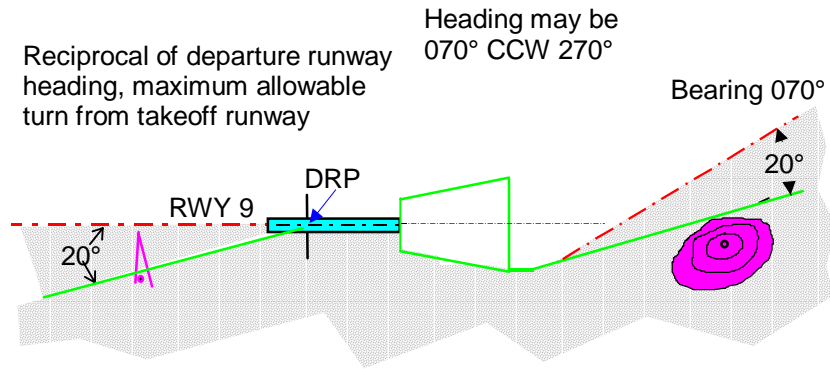
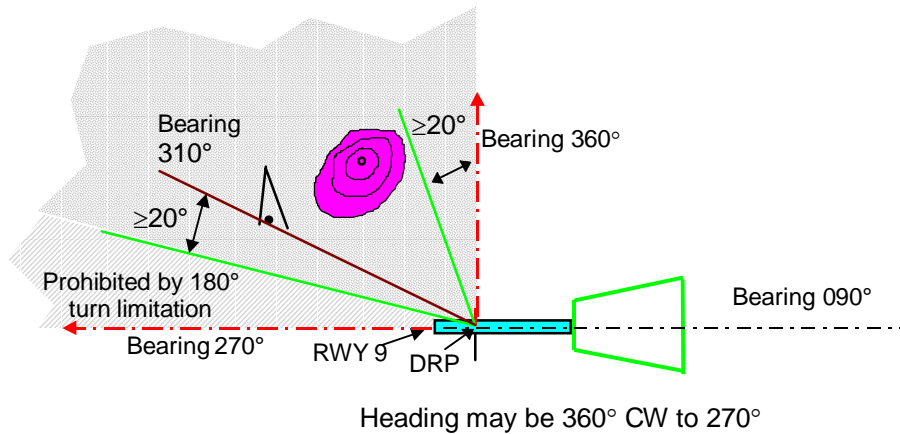
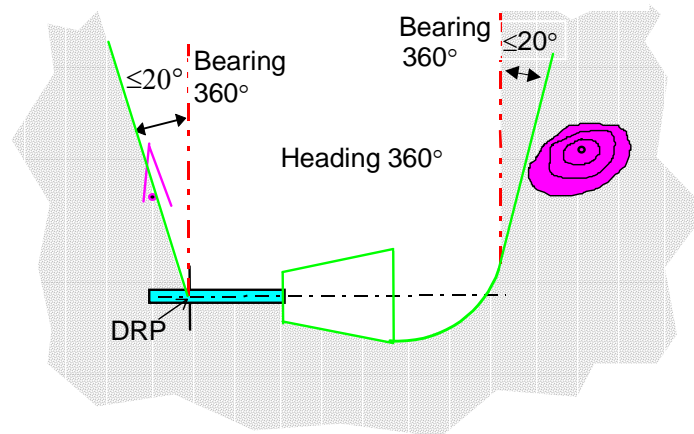

Figure 2-7B shows a sector of 360° clockwise, 270° could be assigned; however, the maximum turn to the right is a heading not in excess of the reciprocal of the takeoff runway heading.

Figure 2-7B. Maximum Heading Limitation



- 2.2.3 b. Assign a single heading for a sector** which has parallel boundaries. The heading must parallel the boundaries. Figure 2-8 shows heading 360° as the only heading allowable.

Figure 2-8. Parallel Boundaries

- 2.2.3** **c. Do not establish a sector** if the boundaries converge. Example: In figure 2-8, if the bearing from the DRP had been 001° or greater or the outer bearing 359° or less, the sector could not be established.

2.3 DVA EVALUATION (ASR Required).

A DVA area based on diverse departure criteria may be established at the request of the AT manager and developed for any airport within the radar facility's area of jurisdiction and radar coverage. When established, reduced separation from obstacles is provided by application of the 40:1 OCS which will be used to radar vector departing IFR aircraft below the MVA/MIA. DVA's should not be developed that require climb gradients greater than 200 ft/NM unless there is no other suitable means to avoid obstacles except in situations where high volumes of high performance aircraft routinely make accelerated climbs.

2.3.1 ICA.

See chapter 1, paragraph 1.6.

2.3.2 DVA "A" and "B" Areas.

Where obstacles penetrate the 40:1 OCS, construct a prohibited sector containing the obstruction(s) so it may be avoided by appropriate radar separation standards. Identify prohibited sectors with boundary lines 3/5 NM, as appropriate, from the penetrating obstacle(s). See figure 2-9.

Figure 2-9. Typical DVA Areas

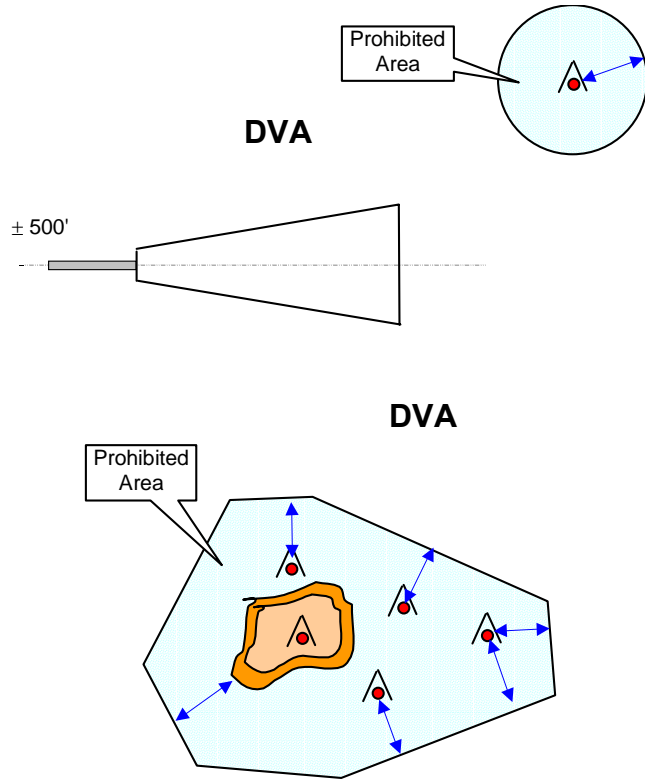

THIS PAGE INTENTIONALLY LEFT BLANK

CHAPTER 3. DEPARTURE ROUTES

3.0 STRAIGHT ROUTE DEPARTURE SEGMENTS.

Straight departures are aligned within 15° of the runway centerline. The initial climb area (ICA) is aligned along the runway centerline for at least 2 NM (see paragraph 1.6). If a turn at the departure end of runway (DER) is desired, expand the obstacle clearance area in the direction of the turn an amount equal to the departure course degree of offset from runway centerline (see figure 3-1). Reduce the obstacle clearance area following the ICA on the side opposite the turn an amount equal to the expansion on the opposite side.

Figure 3-1. Turn $\leq 15^\circ$ at DER

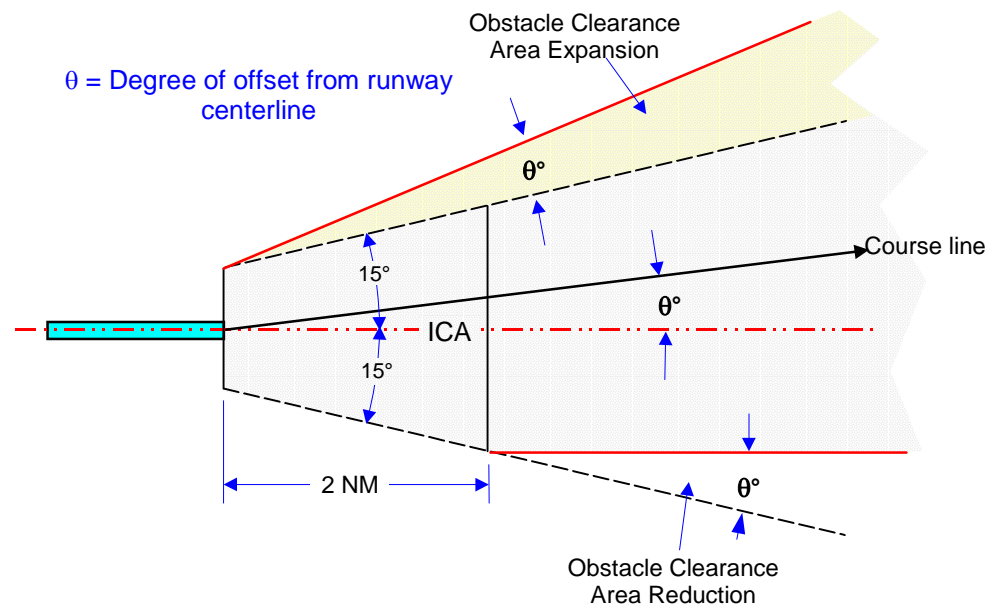

3.1 DEAD RECKONING (DR) DEPARTURE.

The boundary lines of the departure obstacle clearance surface (OCS) splay outward 15° relative to the departure course from the end of the ICA (see figures 3-1 and 3-2). Limit the DR segment to a maximum distance of 10 NM from DER.

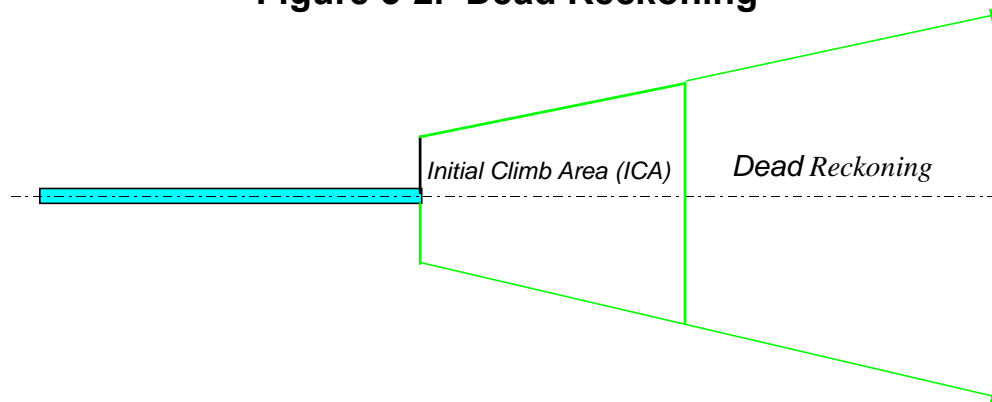
Figure 3-2. Dead Reckoning

3.2 POSITIVE COURSE GUIDANCE (PCG) DEPARTURE, 15° OR LESS.

Calculating Obstruction Area Half Widths. Apply the values from table 3-1 to the following formulae to calculate the obstruction primary area half-width ($1/2 W_p$), and the width of the secondary area (W_s).

$$\begin{aligned} \frac{1}{2} W_p &= k \times D + A \\ W_s &= f_s \times D + A \end{aligned}$$

Table 3-1

$\frac{1}{2}$ Width	k	f_s	D	A
Dep DR	0.267949	none	Distance (ft) from DER	500'
Localizer	0.139562	none	Distance (ft) from ICAE	3756.18'
NDB	0.0333	0.0666	Distance (NM) from facility	1.25 NM
VOR / TACAN	0.059	0.099	Distance (NM) from facility	1 NM

3.3 LOCALIZER GUIDANCE.

The obstruction evaluation area (OEA) begins at the initial climb area end-line (ICAE). The maximum length of the segment is 15 NM from DER. Evaluate for standard climb gradient (SCG) in accordance with paragraph 1.4.1. If necessary, calculate the required minimum climb gradient using the formula in paragraph 1.4.2 where D is the shortest distance to the initial climb area baseline (ICAB) (see figure 3-3).

Figure 3-3. Localizer Area

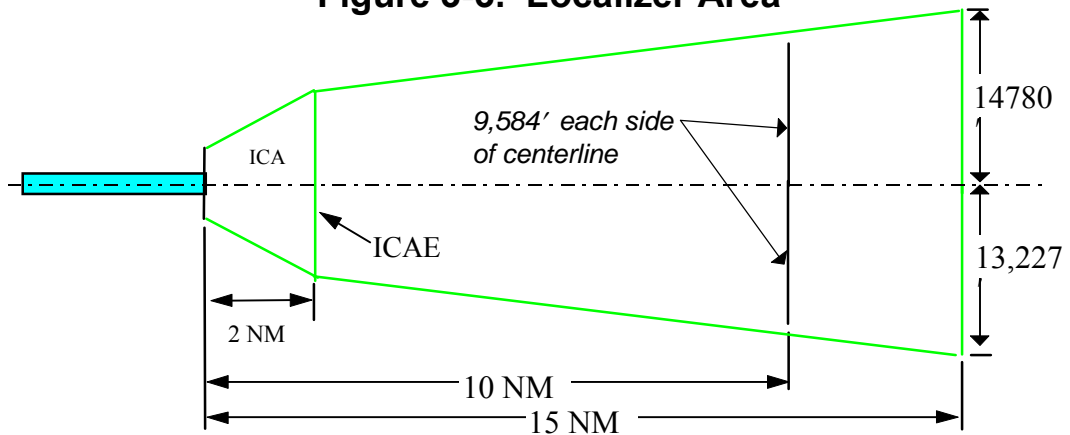

3.3.1 NDB Guidance. Evaluate for SCG in accordance with paragraph 1.4.1. If necessary, calculate the required minimum climb gradient using the formula in paragraph 1.4.2. Figures 3-5, 3-6, and 3-7 illustrate possible facility area configurations.

3.3.2 VOR/TACAN Guidance. Evaluate for SCG in accordance with paragraph 1.4.1. If necessary, calculate the required minimum climb gradient using the formula in paragraph 1.4.2. Figures 3-4, 3-5, and 3-6 illustrate possible facility area configurations.

Figure 3-4. Facility Area and DR Area Relationship

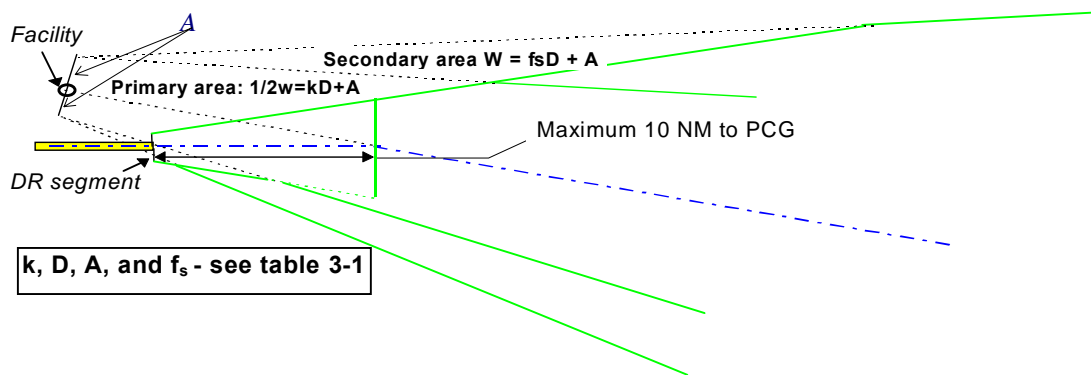
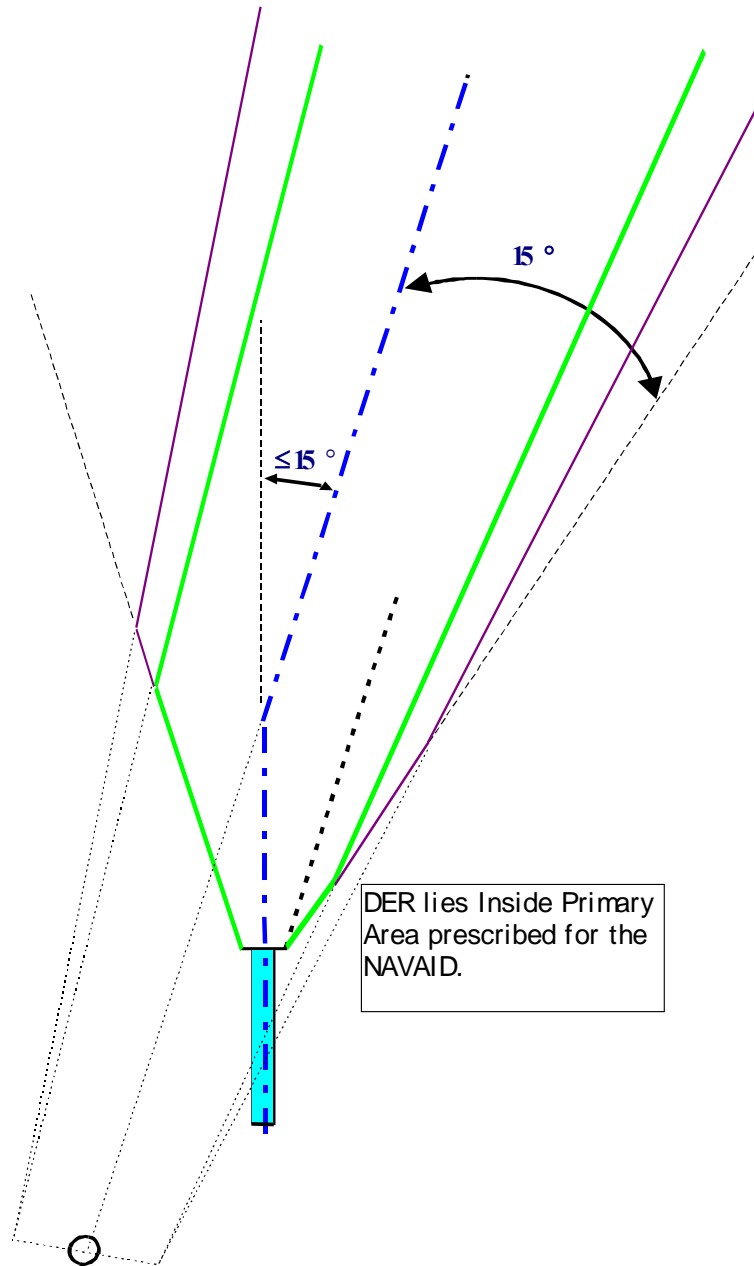

Figure 3-5. DER within Primary Area Facility



3.3.3 Secondary Area Obstructions. Secondary areas may be constructed and employed where PCG is provided.

3.4 RESERVED.

Table 3-2

	<u>Primary Area Outer Boundary radius (R1)</u>			
<u>Aircraft Speeds</u>	<u>90</u>	<u>120</u>	<u>150</u>	<u>175</u>
<u>Turn radii:</u>				
Below 10,000' MSL	0.9	1.4	1.9	2.4
10,000' MSL and above	1.4	2.0	2.7	3.3
<u>Aircraft Speeds</u>	<u>180</u>	<u>210</u>	<u>240</u>	<u>250</u>
<u>Turn radii:</u>				
Below 10,000' MSL	2.5	3.2	3.9	4.2
10,000' MSL and above	3.4	4.3	5.2	5.5
<u>Aircraft speeds</u>	<u>270</u>	<u>300</u>	<u>310</u>	<u>350</u>
<u>Turn radii:</u>				
Below 10,000' MSL	4.7	5.6	6.0	7.3
10,000' MSL and above	6.2	7.3	7.7	9.3

(Speeds include 60-knot omni winds below 10,000' MSL; 90-knot omni winds at 10,000' and above; bank angle 23°.)

3.6 RESERVED.

3.7 TURN TO PCG.

3.7.1 Extend the ICA boundaries as necessary to intersect the boundaries appropriate to the PCG provided. Where the ICA outer boundary will not intersect the PCG boundary, construct an outer boundary radius from the outer edge of the ICA to intersect the PCG boundary. For the radius length, use table 3-2 or the width of the end of ICA, whichever is longer (see figure 3-7).

3.7.2 Specify a course, not aligned with the runway centerline, to intersect a PCG course. The amount of turn is not restricted.

Figure 3-7. ICA Joining PCG Area

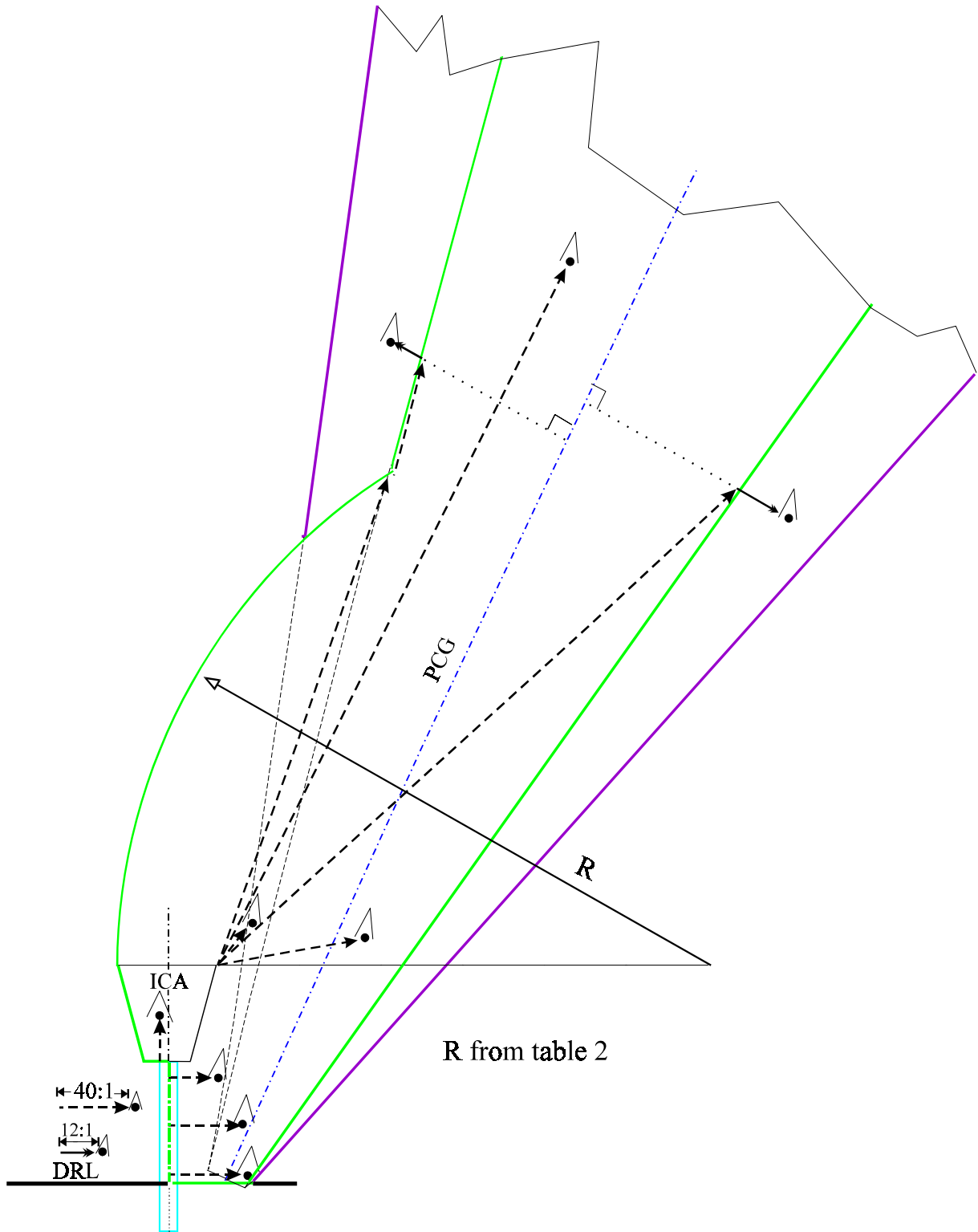

3.8 MULTIPLE TURNS.

Use table 3-1 to establish dimensions of basic trapezoids.

- 3.8.1 Climb to Altitude and Turn; Turns less than 90°.** See figure 3-8. Construct a line from departure reference point (DRP) to edge of obstacle area at the fix denoting the second turn point. Extend splay of ICA to line A,B, (perpendicular to runway centerline extended), where altitude is reached for the turn. Measure out runway centerline extended using SCG.
- 3.8.1 a. Align the centerline** of trapezoid alpha, through point C (end of ICA on runway centerline extended).
- 3.8.1 b. Construct an arc from point A** using radius R1 (table 3-2) centered on point B. Construct a tangent from the arc to the boundary of the secondary area of the next segment, (trapezoid beta), 30° relative to trapezoid alpha centerline.
- 3.8.1 c. Construct trapezoid beta.** Extend the outer boundary area, radius “d”, to join trapezoid cocoa. Inside boundaries join at the primary and secondary intersections.
- 3.8.1 d. Construct trapezoid cocoa** and its associated segment, if necessary, to join en route structure.

Figure 3-8. Climb to an Altitude and Turn Direct to Fix with Multiple Turns.

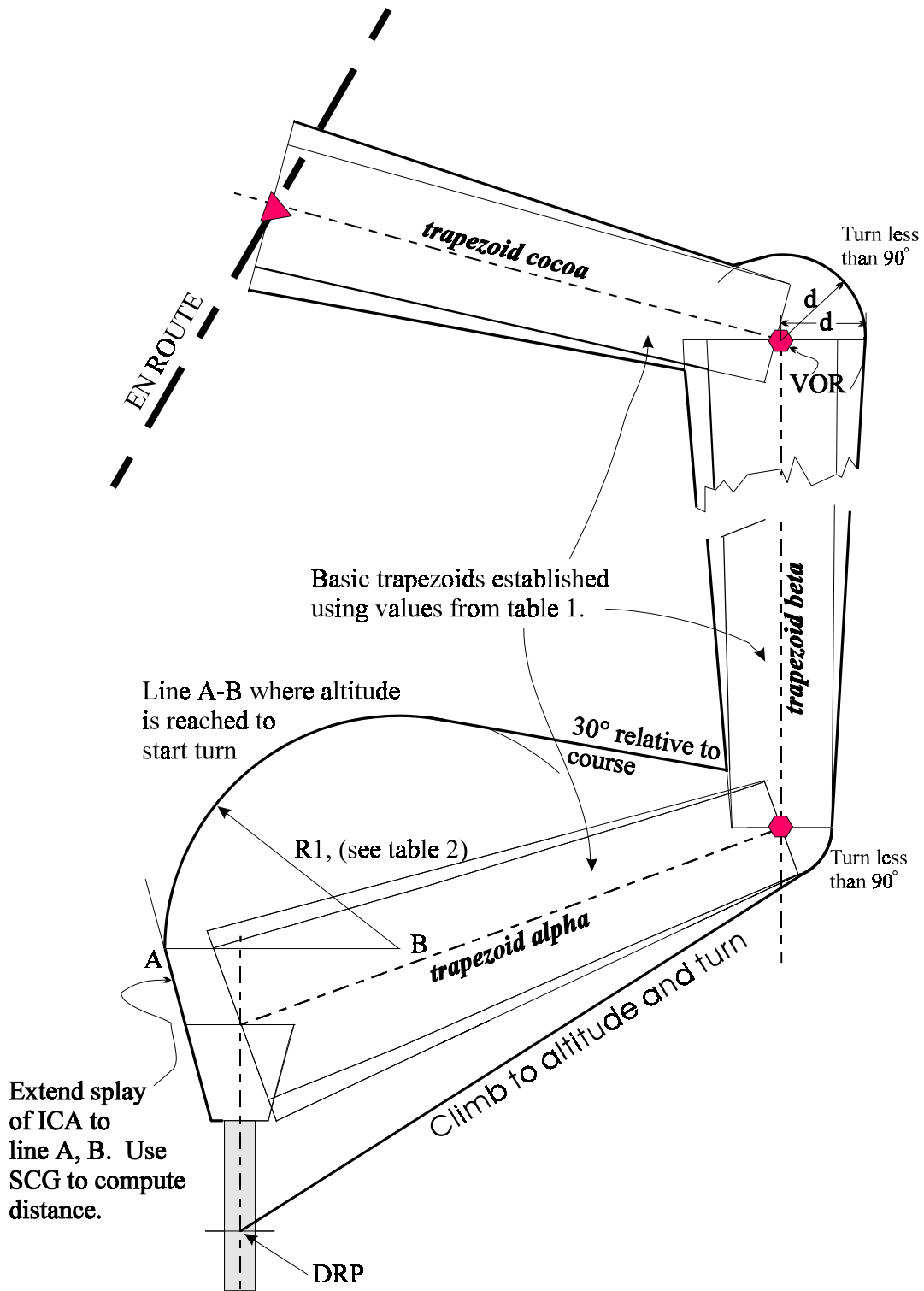

- 3.8.2** **Climb to Intercept a Course.** See figure 3-9. Construct a 15° splay relative to runway centerline from the departure reference point (DRP) to the secondary boundary of trapezoid delta (inside of turn) area. System accuracy line of delta must intercept runway centerline at or beyond DER.
- 3.8.2** **a. Extend the splay of ICA to line A, B.** System accuracy line of trapezoid delta (outside of turn) intercepts the ICA splay at point A.
- 3.8.2** **b. Construct an arc from point A** using radius R1 (table 3-2) centered on point B. Construct a tangent from the arc to the boundary of next segment (trapezoid echo) 30° relative to trapezoid delta centerline.
- 3.8.2** **c. Construct trapezoids echo and fox** as necessary. Provide a 2-NM lead area when turns are more than 90°, prior to the “VOR” turning into trapezoid fox. Specify a 2-mile lead when possible with a radial, bearing, or DME. When unable to identify the lead point, construct and provide a 2-mile lead area for evaluation of obstacles. Outside protection arc must be as large as the end of the trapezoid, i.e., "d" at fix jiffy. In the segment containing trapezoid fox, note primary “line papa” and secondary “line sandy” originate from the 2-mile lead of trapezoid echo.

Figure 3-9. Climb RWY Heading to Intercept a Course With Multiple Turns.

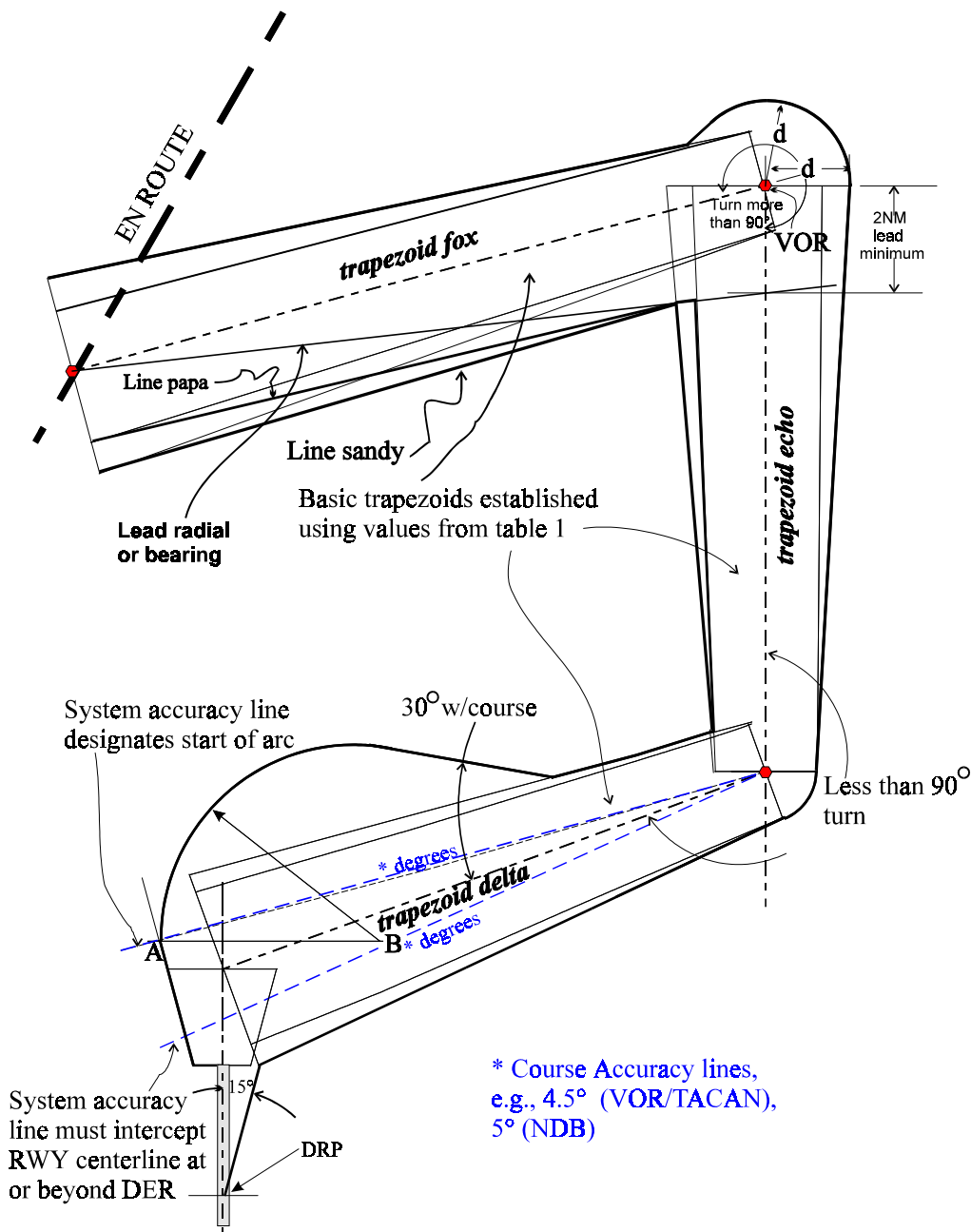

3.8.3

Figure 3-10 illustrates multiple turns more than 90°. Initial course intercepts positive course of trapezoid gulf after takeoff from DER. The obstacle area radius is constructed from point A with a tangent 30° relative to the course in trapezoid gulf. The area formed around the intersection of E with trapezoid hotel takes precedence over the 2-NM lead requirement. Primary and secondary areas can be established on the inside of the turn in trapezoid hotel because the 2-mile lead does not cut off any of the primary area.

Figure 3-10. Climb to Intercept Course.

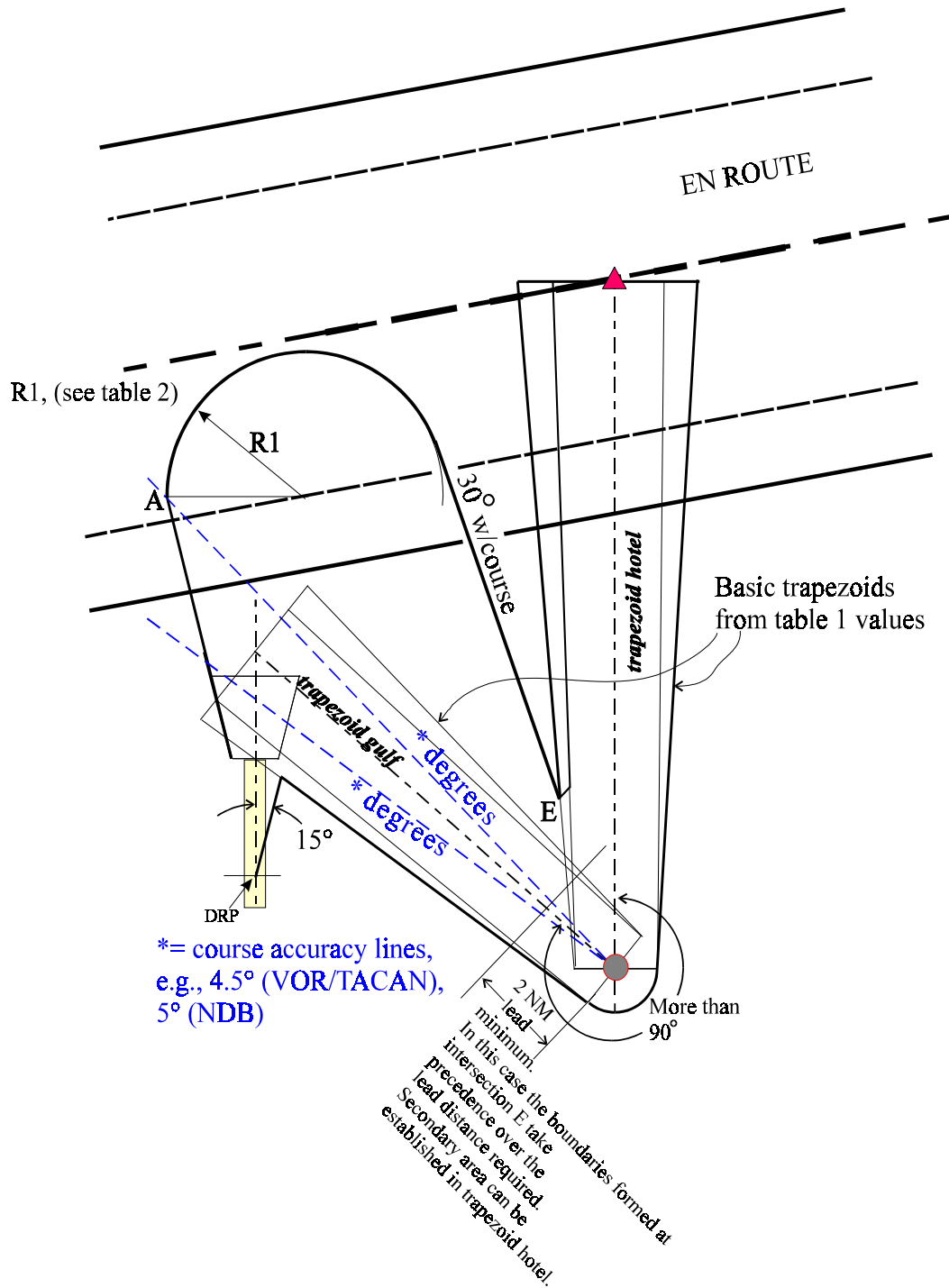

3.8.4

Figure 3-11 illustrates multiple turns more than 90°. Publish either a radial, bearing, or a DME when available. Construct a 2-NM lead even though no radial, bearing, nor DME is available. This provides a lead area for the pilot's early turn. Note how the intersections at E and F form the boundaries of obstacle clearance areas. Point E is established abeam the 2-mile lead. The dark lines around point E form a primary area boundary. A secondary area cannot be established on the inside area of trapezoid juniper because the 2-mile lead forms the area that takes precedence over the normal primary and secondary areas at "e".

Figure 3-11. Multiple turns.

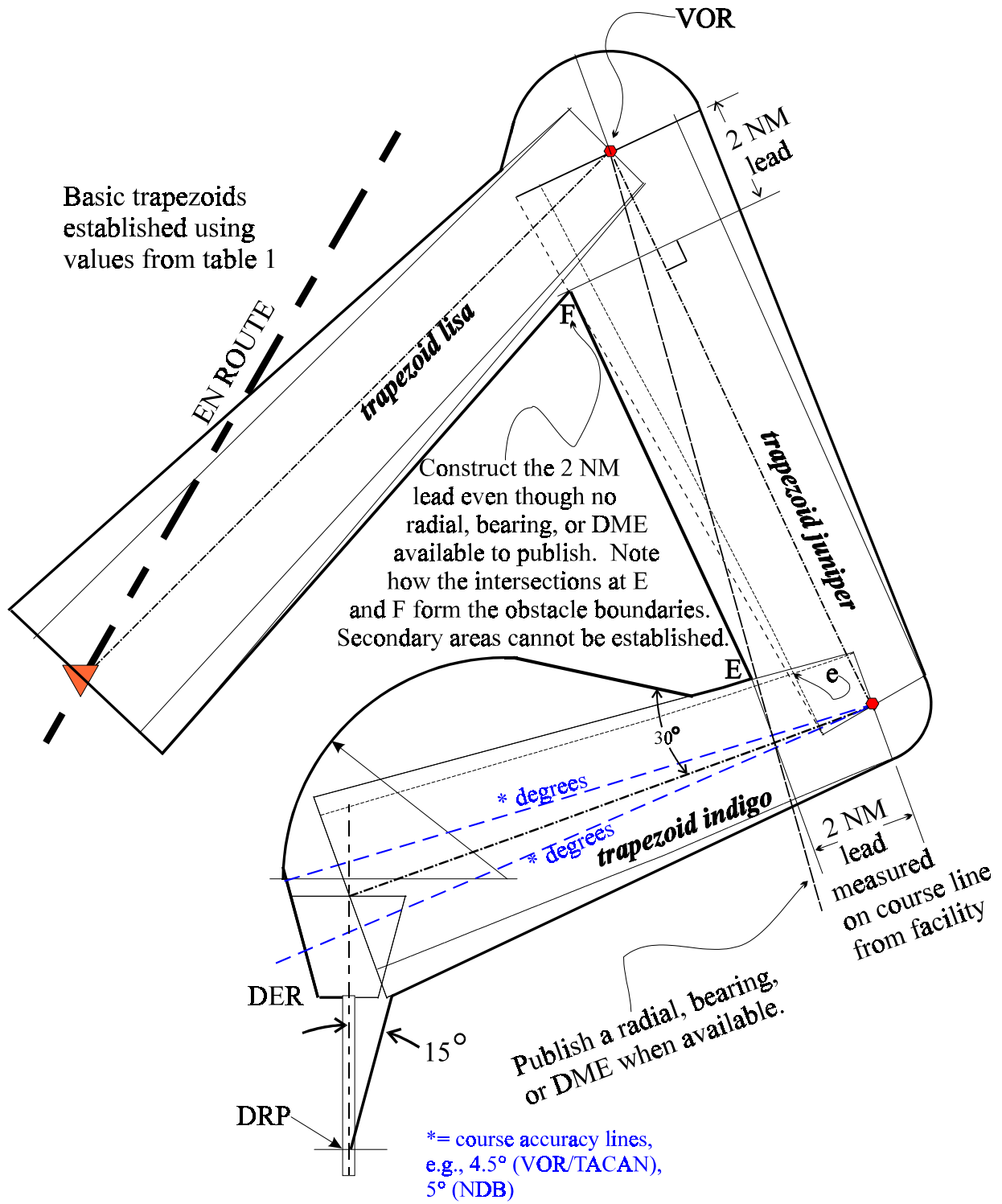

- 3.8.5** **Figure 3-12 illustrates the 2-mile lead** not required when lead point is within primary area of en route course.

Figure 3-12. Turn on to En Route Course.

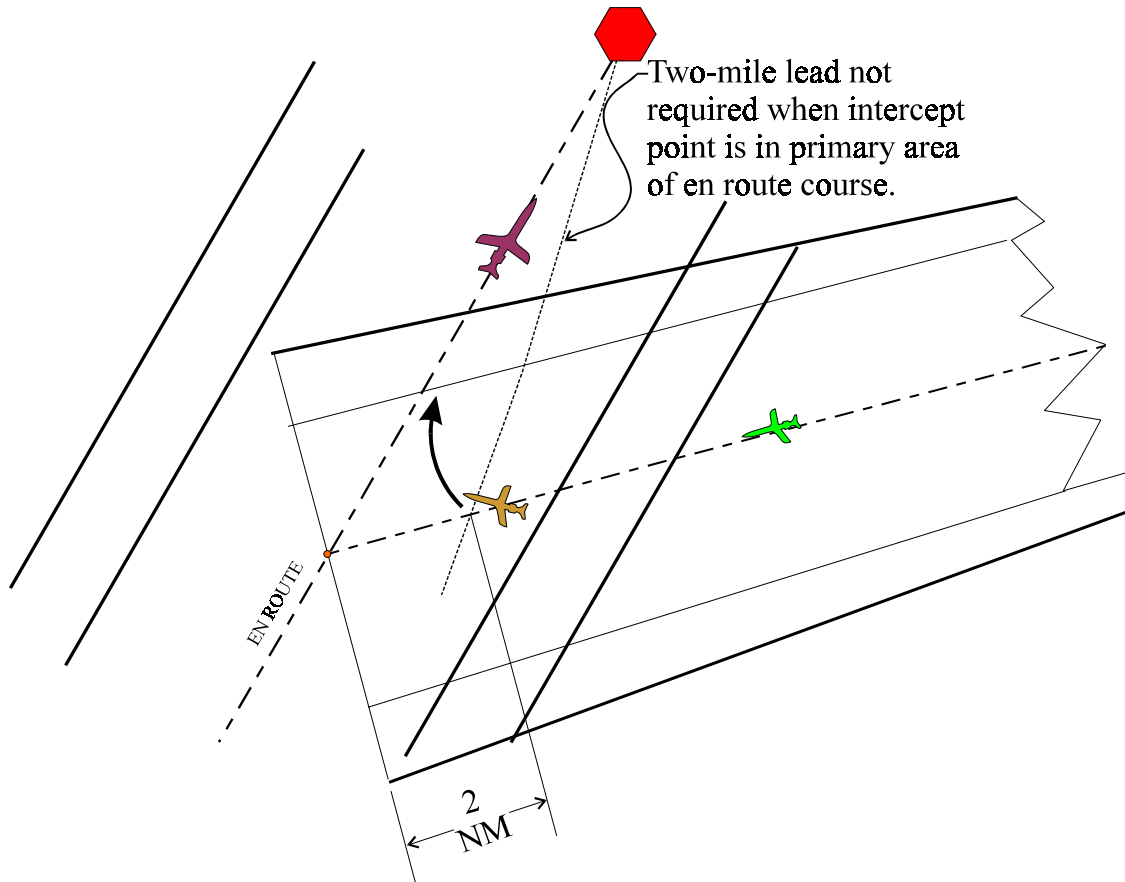

- 3.8.6** **Evaluation of Multiple Turn Areas.** See figures 3-13 and 3-14.

- 3.8.6 a. Measure 40:1 straight-line distance** from lines d-c-b of the ICA directly to the obstacles outside of the ICA associated with trapezoid alpha in figure 3-13 and trapezoid gulf in figure 3-14. Measure 40:1 from runway centerline to obstacles abeam the runway between the DRP and the DER. Points b and c are at the end of the ICA, a and d at corners of the ICA abeam the DER. In figure 3-13, no secondary areas exist in trapezoid alpha's segment, and in figure 3-14, no secondary evaluation is allowed for the far turn from DER because the beginning of PCG cannot be determined. However, on the inside turn area a secondary area evaluation could be allowed for trapezoid gulf's segment.

- 3.8.6 b. Measure 40:1 to point E for obstacles** in trapezoids beta, figure 3-13, and hotel, figure 3-14, segments, respectively. Measure 12:1 into secondary area from edge of primary area perpendicular to the segment's course. Convert the secondary area obstacles to primary equivalent at edges of primary area. Measure 40:1 to the conversion points to assess appropriate obstacle clearance.
- 3.8.6 c. Measure 40:1 to E, then 40:1 down the edge** of the primary area of trapezoid beta from E to F to obstacles in trapezoid cocoa's segment. From F measure 40:1 to obstacles in primary area of trapezoid cocoa, figure 3-13. Measure along edge of primary area to a point abeam the obstacles in secondary area. Measure 12:1 from edge of primary area to the obstacle in secondary area perpendicular to applicable course line. Perform secondary area obstacle evaluation.
- 3.8.6 d. Climbing in a Holding Pattern.** When a climb in a holding pattern is used, no obstacle shall penetrate the holding pattern obstacle clearance surface. This surface begins at the end of the segment, F-G, figure 3-14, leading to the holding fix. Its elevation is that of the departure OEA at the holding fix. It rises 40:1 from the nearest point of the F-G line to the obstacle in the primary area. It also rises 40:1 to the edge of the primary area of the holding pattern abeam an obstacle in the secondary area of the holding pattern. In the secondary area, the surface rises 12:1 to the obstacle measuring the shortest distance between the obstacle and the edge of the primary area (see figure 3-14). The holding pattern altitude must have a level surface evaluation of 1,000 feet.

Figure 3-13. Climb to an Altitude and Turn Direct to Facility with Multiple Turns.

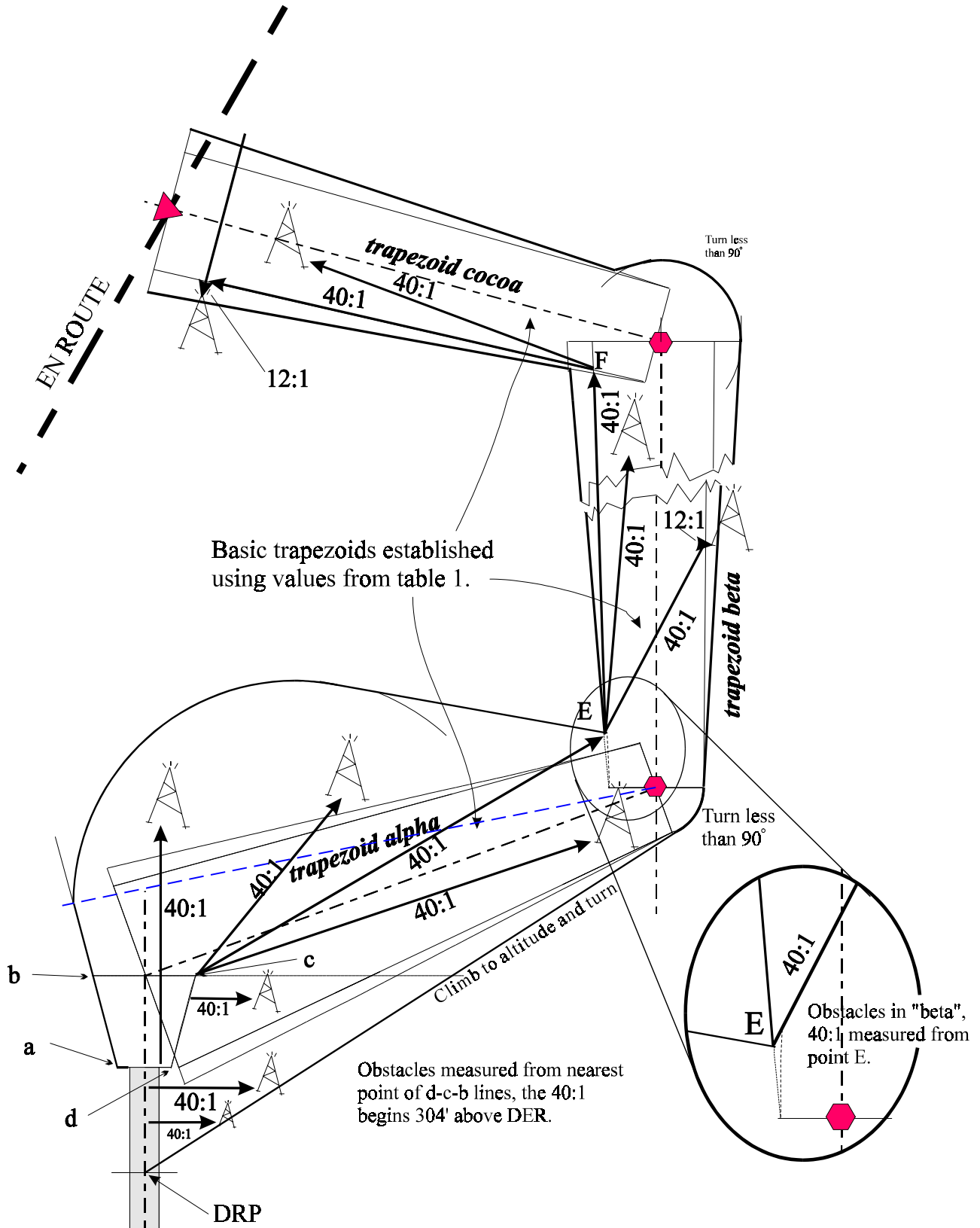
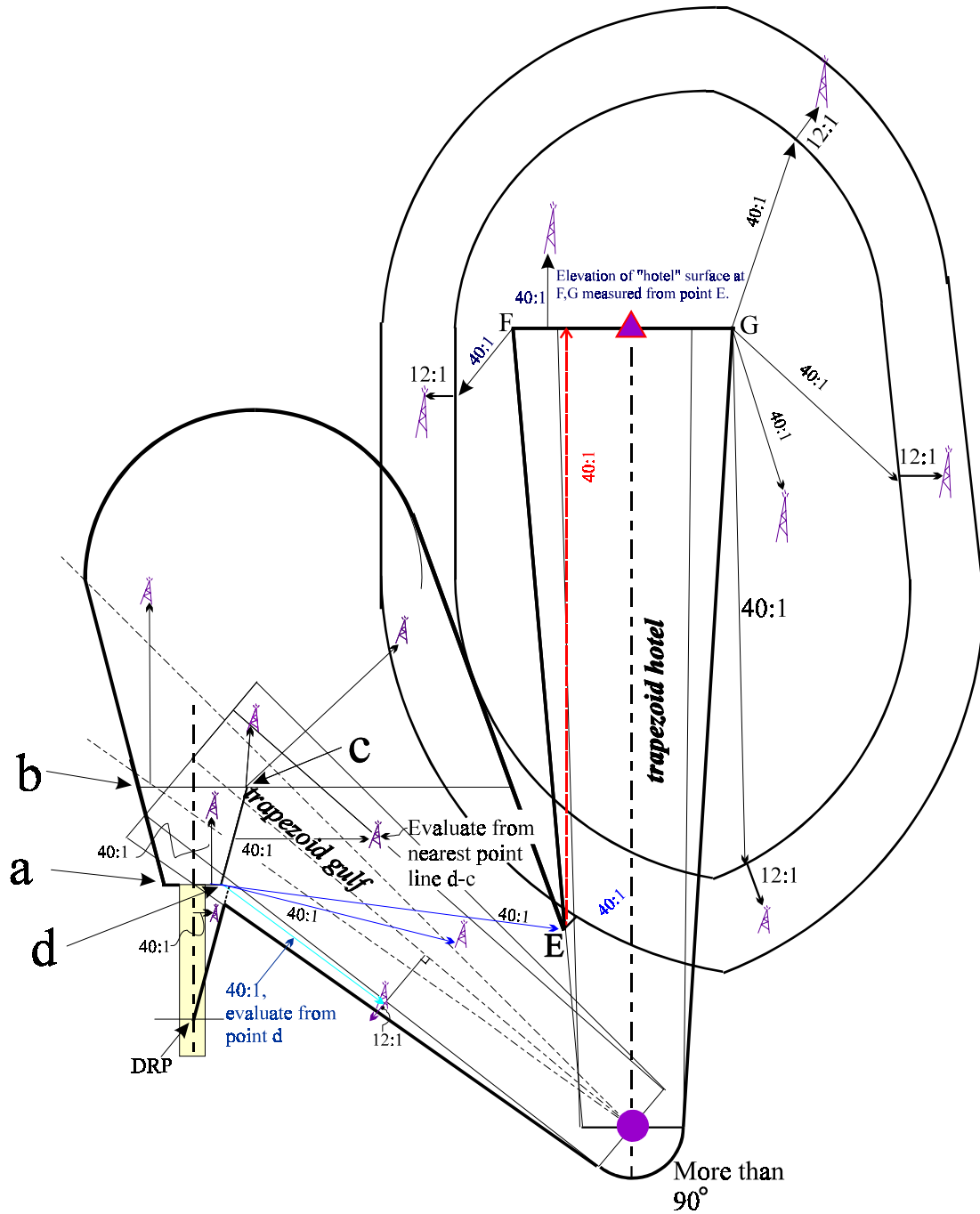

Figure 3-14. Climb in a Holding Pattern, Turns More Than 90 Degrees Evaluation.



CHAPTER 4. VISUAL CLIMB OVER AIRPORT (VCOA)

4.0 GENERAL.

VCOA is an alternative method for pilots to depart the airport where aircraft performance does not meet the specified climb gradient. Development of a VCOA is mandatory when obstacles more than 3 statute miles from the departure end of runway (DER) require a greater than 200 ft/NM climb gradient.

4.1 BASIC AREA.

Construct a visual climb area over the airport using the airport reference point (ARP) as the center of a circle (see figure 4-1). Use R1 in table 4-1 plus the distance ARP to the most distant runway end as the radius for the circle.

Figure 4-1. VCA

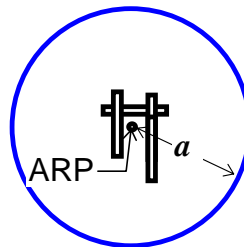

$a = R1$ (table 1-3) plus the Distance from ARP to most distant DER

Select 250 KIAS as the standard airspeed and apply the appropriate MSL altitude to determine the R1 value. Use other airspeeds in table 4-1, if specified on the procedure, using the appropriate radius for the selected airspeed. Altitude must equal or exceed field elevation. The VCA must encompass the area of the ICA from the departure runway(s). Expand the VCA radius if necessary to include the ICA (see figure 4-2).

Figure 4-2. VCA Expanded

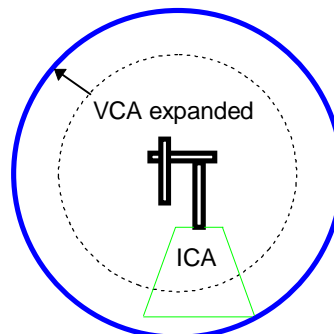

The VCA must completely encompass the ICA.

Table 4-1. Radius Values

Altitudes MSL	2,000'	5,000'	10,000'
Speed KIAS			
90	2.0	2.0	2.0
120	2.0	2.0	2.0
180	2.0	2.0	2.5
210	2.1	2.5	3.2
250	2.8	3.4	4.2
310	4.2	4.9	6.0
350	5.2	6.0	7.3

(Table 4-1 speeds include 30-knot tail winds up to 2,000' MSL, 45-knot tail winds up to 5,000' MSL, and 60-knot tail winds at 10,000' MSL; bank angle: 23°.)

4.2 VCOA EVALUATION.

4.2.1 Diverse VCOA.

Policy Memo
Dec 28 2007

Identify the highest obstruction within the visual climb area (VCA). This is the preliminary height of the VCA level surface. Evaluate a 40:1 surface from the edge of the level surface. If the 40:1 surface is penetrated, raise the VCA level surface height by the amount of the greatest penetration (see figure 4-3). Determine the VCOA "climb-to" altitude using the following formula:

climb to altitude = level surface MSL height + 250' ROC + adjustments (vol. 1, para 323a)

Example : $5124 + 250 + 0 = 5374$ rounds to 5400'

Where OCS height = 5124

adjustments = 0

Figure 4-3. Diverse VCOA Evaluation

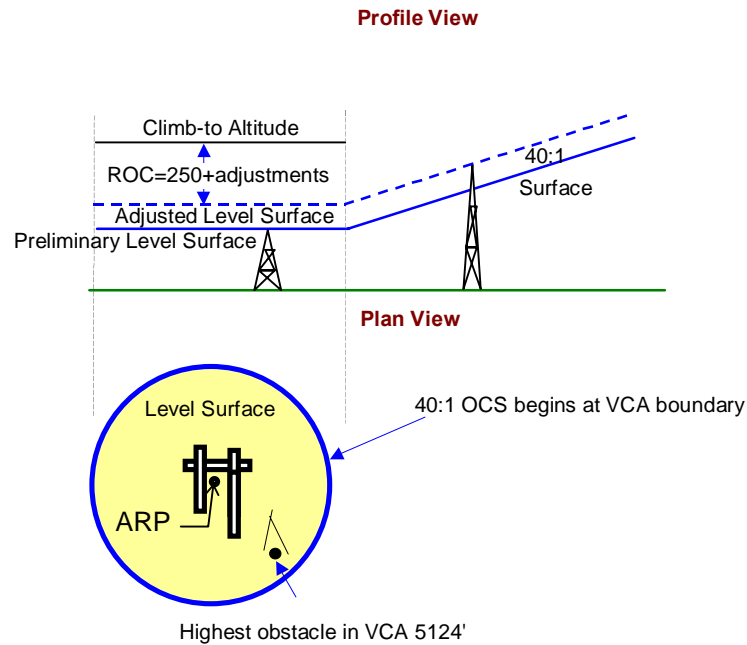

4.2.2 Departure Routes.

Where VCOA Diverse Departure is not feasible, construct a VCOA departure route.

- 4.2.2 a. Construct** the VCA per paragraph 4.1.
- 4.2.2 b. Determine** the preliminary level surface height as in paragraph 4.2.1.
- 4.2.2 c. Locate**, within the VCA, the beginning point of the route.
- 4.2.2 d. Construct** the departure route using criteria for the navigation system desired. The 40:1 surface rise begins along a line perpendicular to the route course and tangent to the VCA boundary (see figure 4-4).
- 4.2.2 e. OCS Evaluation.** Where obstacles penetrate the route 40:1 OCS:
 - 4.2.2 e. (1)** Raise the VCA level surface the amount of penetration. Determine the climb-to altitude using the formula below, **or...**

$$\text{climb to altitude} = \text{level surface MSL height} + 250' \text{ ROC} + \text{adjustments (vol. 1, para 323a)}$$

$$\text{Example : } 5124 + 250 + 0 = 5374 \text{ rounds to } 5400'$$

$$\begin{aligned} \text{Where OCS height} &= 5124 \\ \text{adjustment} &= 0 \end{aligned}$$

4.2.2 e. (2) Determine a climb gradient that will clear the obstacle using the formula:

$$CG = \frac{a - b}{0.76 \times d}$$

where a = obstacle MSL altitude
 b = VCA climb - to altitude
 d = distance (NM) from 40 : 1 origin to obstacle

Example : $CG = \frac{3379 - 2100}{0.76 \times 5.34} = 315.15 \text{ ft/NM}$

Calculate altitude (alt) that the CG may be discontinued :

$$alt = b + (d \times CG)$$

Example :

$$alt = 2100 + (5.34 \times 316) = 3787.44 \text{ round up to } 3800'$$

Figure 4-4. Route Out of VCA

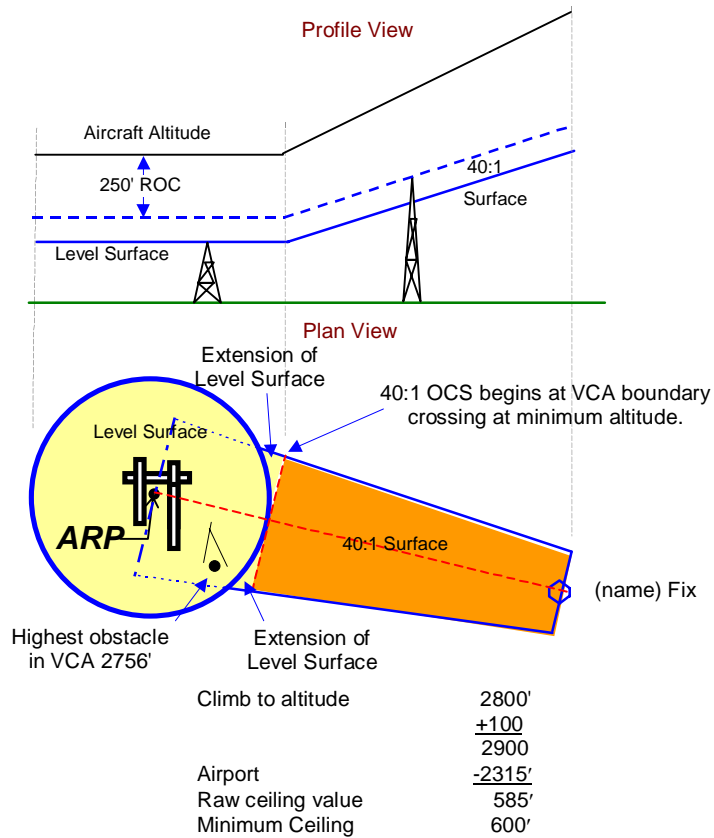

4.2.3 Published Annotations.

The procedure must include instructions specifying an altitude to cross a fix/location over the airport, followed by routing and altitude instructions to the en route system. Example: "Climb in visual conditions to cross Wiley Post airport

westbound at or above 6,000', then climb to FL180 via AMA R-098 to AMA VORTAC", "Climb in visual conditions to cross DXTER eastbound at 5,000', then via LEX R-281 to LEX." (see figure 4-5).

Figure 4-5. VCOA Departure Route

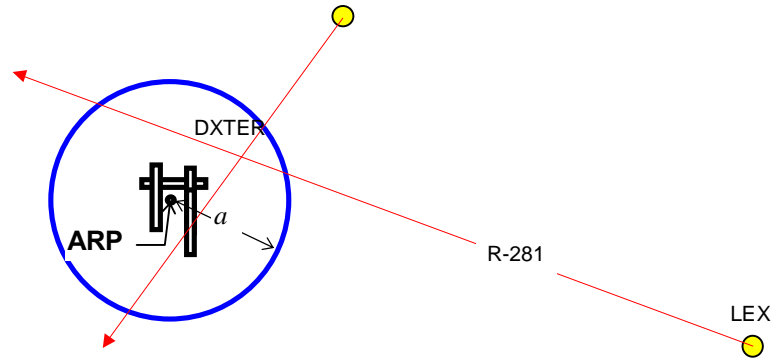

4.3 CEILING AND VISIBILITY.

Publish a ceiling that is the 100-foot increment above the "climb-to" altitude over the VCA. Obstacles inside the VCA are subject to see and avoid maneuvers. Obstacles outside the VCA may be avoided by publishing a ceiling above an altitude that must be attained inside the VCA over a specified fix or identifiable point. From this altitude, a 40:1 OCS from the VCA boundary clears all obstacles outside the VCA omni-directionally, or along a route of flight (see figures 4-3, 4-4). Determine the published visibility from table 4-2.

Table 4-2. Visibility

Altitudes MSL	2,000'	5,000'	10,000'
<u>Speed KIAS</u>			
90	1	1	1
120	1	1	1 1/4
180	1 1/2	2	2 1/2
210	2	2 1/2	2 3/4
250	2 1/2	3	3
310	3	3	3
350	3	3	3

THIS PAGE INTENTIONALLY LEFT BLANK

FAA ORDER

8260.3B

Army
Navy
Coast Guard
Air Force

TM 95-226
OPNAV Inst. 3722.16C
CG 318
AFMAN 11-226(I)

**UNITED STATES STANDARD
FOR
TERMINAL
INSTRUMENT
PROCEDURES
(TERPS)**



VOLUME 5

**HELICOPTER AND
POWERED LIFT
INSTRUMENT PROCEDURE
CONSTRUCTION**

RESERVED

U. S. DEPARTMENT OF TRANSPORTATION
FEDERAL AVIATION ADMINISTRATION

CHANGE

**DEPARTMENT OF TRANSPORTATION
FEDERAL AVIATION ADMINISTRATION**

8260.3B CHG 1

2/6/79

Army TM 95-226
Navy OPNAV Inst 3722.16C
Air Force AFM 55-9
Coast Guard CG 318

**Cancellation
Date: RETAIN**

SUBJ: UNITED STATES STANDARD FOR TERMINAL INSTRUMENT PROCEDURES (TERPS)

PURPOSE. In addition to minor revisions, clarifications, and editorial corrections, this change transmits a new Table 6, Effect of HAT/HAA on Visibility Minimums (chapter 2), and adds new Chapter 12, Departure Procedures.

PAGE CONTROL CHART

Remove Pages	Dated	Insert Pages	Dated
iii thru vi	7/76	iii thru vi	2/79
xvii thru xx	7/76	xvii thru xxi	2/79
1 thru 8	7/76	1	7/76
		2 thru 8	2/79
11 thru 16	7/76	11 and 12	2/79
		13	7/76
		14 thru 16	2/79
19 thru 30	7/76	19 thru 29	2/79
		30	7/76
33 and 34	7/76	33	2/79
		34	7/76
39 thru 44	7/76	39 thru 44	2/79
53 and 54	7/76	53	7/76
		54	2/79
75 thru 92	7/76	75 thru 92	2/79
95 thru 102	7/76	95 thru 102	2/79
105 thru 110	7/76	105	7/76
		106 thru 110	2/79
113 (and 114)	7/76	113 thru 124	2/79
Appendix 2		Appendix 2	
Pages 1 and 2	7/76	Pages 1 and 2	2/79
5 and 6	7/76	5 and 6	2/79
11 and 12	7/76	11 and 12	2/79
Appendix 4		Appendix 4	
Pages 1 thru 6	7/76	Pages 1 thru 6	2/79
Appendix 6		Appendix 6	
Pages 11 and 12	7/76	Page 11	7/76
		12	2/79

J. A. Ferrarese

J. A. FERRARESE, Acting Director, Flight Standards Service

Distribution: ZFS-827

Initiated By: AFS-700

THIS PAGE INTENTIONALLY LEFT BLANK

CHANGE

**DEPARTMENT OF TRANSPORTATION
FEDERAL AVIATION ADMINISTRATION**

8260.3B CHG 2

Army TM 95-226
Navy OPNAV Inst 3722.16C
Air Force..... AFM 55-9
Coast Guard CG 318

10/22/79

**Cancellation
Date: Retain**

SUBJ: UNITED STATES STANDARD FOR TERMINAL INSTRUMENT PROCEDURES (TERPS)

PURPOSE. Provide artwork for Figure 101 and related page revisions inadvertently omitted in the initial printing process of Change 1.

PAGE CONTROL CHART

Remove Pages	Dated	Insert Pages	Dated
7 and 8	2/79	7 8	2/79 10/79
91 thru 94	7/76	91 92 and 93 94	7/76 10/79 7/76

**KENNETH S. HUNT
Director of Flight Operations**

Distribution: ZFS-827

Initiated By: AFO-700

THIS PAGE INTENTIONALLY LEFT BLANK

CHANGE

**DEPARTMENT OF TRANSPORTATION
FEDERAL AVIATION ADMINISTRATION**

8260.3B CHG 3

ArmyTM 95-226
Navy ... OPNAV Inst 3722.16C
Air Force AFM 55-9
Coast Guard CG 318

6/3/80

**Cancellation
Date:** Retain

SUBJ: UNITED STATES STANDARD FOR TERMINAL INSTRUMENT PROCEDURES (TERPS)

PURPOSE. This change incorporates a new Chapter 17, Enroute Criteria into the TERPs handbook and is concurred in by the TERPs signatories. These criteria formerly were contained in FAA Handbook 8260.19, Flight Procedures and Airspace, Chapter 8, Criteria. This administrative action focalizes all instrument procedures related criteria into the TERPs handbook for reasons of homogeneity. A change to 8260.19 will be issued to withdraw Chapter 8. TERPS Chapters 13, 14, 15, and 16 are reserved for future use.

PAGE CONTROL CHART

<u>Remove Pages</u>	<u>Dated</u>	<u>Insert Pages</u>	<u>Dated</u>
xvii thru xviii	2/79	xvii thru xxiii	6/80
xix	7/76	Chapter 17	
xx thru xxi	2/79	Pages 173 thru 187	6/80
Appendix 6		Appendix 6	
Pages 1 thru 11	7/76	Pages 1 thru 20	6/80
12	2/79		
13 thru 20	7/76		

KENNETH S. HUNT
Director of Flight Operations

THIS PAGE INTENTIONALLY LEFT BLANK

CHANGE**DEPARTMENT OF TRANSPORTATION
FEDERAL AVIATION ADMINISTRATION**

8260.3B CHG 4

4/1/83

SUBJ: UNITED STATES STANDARD FOR TERMINAL INSTRUMENT PROCEDURES (TERPS)

PURPOSE. This change updates references to responsible FAA organizations; defines the use of shall, should, and may; removes reference to L/MFR; adds Chapter 14 SDF Procedures; adds Figure 129B PAR, corrects minor typographical errors; and completely updates Appendix 5, Approach Lighting Systems and Appendix 6, Alphabetical Index.

PAGE CONTROL CHART			
Remove Pages	Dated	Insert Pages	Dated
v thru xvi	7/76	v thru xxv	4/1/83
xvii thru xxiii	6/80		
1	7/76	1 thru 26	4/1/83
2 and 3	2/79	29 thru 34	4/1/83
4	7/76	37 and 38	4/1/83
5 (and 6)	2/79	39 thru 44-1 (and 44-2)	4/1/83
7	2/79	65 thru 68	4/1/83
8	10/79	77 and 78	4/1/83
9 thru 11	7/76	87 thru 90	4/1/83
12	2/79	99 and 100	4/1/83
13	7/76	137 and 138	4/1/83
14 thru 16	2/79	175 and 176	4/1/83
17 and 18	7/76	181 and 182	4/1/83
19 and 20	2/79		
21 and 22	7/76		
23 thru 26	2/79		
29	2/79		
30 thru 32	7/76		
33	2/79		
34	7/76		
37 and 38	7/76		
39 thru 44	2/79		
65 thru 68	7/76		
77	7/76		
78	2/79		
87	2/79		
88	7/76		
89 and 90	2/79		
99	7/76		
100	2/79		
175 and 176	6/80		
181 and 182	6/80		

Distribution: ZVS-827

Initiated By: AVN-200/AFO-700

PAGE CONTROL CHART CONTINUED

Remove Pages	Dated	Insert Pages	Dated
APPENDIX 2		APPENDIX 2	
3 and 4	7/76	3 and 4	4/1/83
9 and 10	7/76	9 thru 17(and 18)	4/1/83
11	2/79		
12	7/76		
13 thru 16	7/76		
APPENDIX 5		APPENDIX 5	
1 thru 10	7/76	1 thru 8	4/1/83
APPENDIX 6		APPENDIX 6	
1 thru 20	6/80	1 thru 19(and 20)	4/1/83

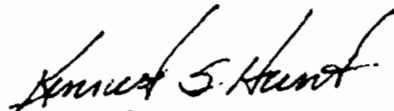
Kenneth S. Hunt
Director of Flight Operations

CHANGE

**DEPARTMENT OF TRANSPORTATION
FEDERAL AVIATION ADMINISTRATION**

8260.3B CHG 5

Army. TM 95-226
Navy. OPNAV Inst 3722.16C
Air Force. AFM 55-9
Coast Guard. CG 318

11/15/83

SUBJ: UNITED STATES STANDARD FOR TERMINAL INSTRUMENT PROCEDURES (TERPS)

PURPOSE. This change updates references to Federal agencies, corrects distribution lists, and makes minor changes to criteria references which were made necessary by the automation of procedures development. Several minor typographical errors are also corrected.

PAGE CONTROL CHART

Remove Pages	Dated	Insert Pages	Dated
iii - iv	2/79	iii - iv	11/15/83
v - vi	4/1/83	v	11/15/83
		vi	4/1/83
5 (and 6)	4/1/83	5 (and 6)	11/15/83
17 and 18	4/1/83	17	11/15/83
		18	4/1/83
23 and 24	4/1/83	23	4/1/83
		24	11/15/83
27 and 28	2/79	27	11/15/83
		28	2/79
31 and 32	4/1/83	31	11/15/83
		32	4/1/83
33 and 34	4/1/83	33 through 34-2	11/15/83
181 and 182	4/1/83	181	4/1/83
		182	11/15/83

William T. Brennan
Acting Director of Flight Operations

Distribution: ZVS-827

Initiated By: AVN-200/AFU-200

THIS PAGE INTENTIONALLY LEFT BLANK

1/27/84

Army. TM 95-226
Navy. OPNAV Inst 3722.16C
Air Force. AFM 55-9
Coast Guard. CG 318

SUBJ: UNITED STATES STANDARD FOR TERMINAL INSTRUMENT PROCEDURES (TERPS)

PURPOSE. This change corrects three errors included in previous changes. It deletes the requirement to apply excessive length of final penalty to circling procedures, includes the formula for one-half the width of the primary area in figure 65, and replaces incorrect NATO STANDARD (C) lighting figure with figures showing the two systems being used.

PAGE CONTROL CHART

Remove Pages	Dated	Insert Pages	Dated
37 and 38	4/1/83	37 38	4/1/83 1/27/84
65 and 66	4/1/83	65 66	4/1/83 1/27/84
APPENDIX 5 1 and 2	4/1/83	APPENDIX 5 1 and 2	1/27/84

William T. Brennan
William T. Brennan
Acting Director of Flight Operations

THIS PAGE INTENTIONALLY LEFT BLANK

CHANGE

**DEPARTMENT OF TRANSPORTATION
FEDERAL AVIATION ADMINISTRATION**

8260.3B CHG 7

Army TM 95-226
Navy OPNAV Inst 3722 16C
Air Force AFM 55-9
Coast GuardCG 318

12/6/84

SUBJ: UNITED STATES STANDARD FOR TERMINAL INSTRUMENT PROCEDURES (TERPS)

PURPOSE. This change updates Navy distribution requirements, updates portions of the Table of Contents, revises reference to aircraft categories, provides easier to follow instructions on dead reckoning (DR) initial segments, gives revised criteria on step-down fixes, revised holding areas/obstacle clearance, revised standard alternate minimums, a revised Section 1 for PAR straight missed approach, and corrects several typographical errors in references in Chapter 17.

PAGE CONTROL CHART

Remove Pages	Dated	Insert Pages	Dated
v	11/15/83	v	12/6/84
vi	4/1/83	vi	12/6/84
vii	4/1/83	vii	4/1/83
viii	4/1/83	viii	12/6/84
xxi & xxii	4/1/83	xxi & xxii	12/6/84
xxiii	4/1/83	xxiii	4/1/83
xxiv	4/1/83	xxiv	12/6/84
xxv (and xxvi)	4/1/83	xxv (and xxvi)	12/6/84
7	4/1/83	7	12/6/84
8	4/1/83	8	4/1/83
11 through 14	4/1/83	11 through 14	12/6/84
33	11/15/83	33	12/6/84
34	11/15/83	34	12/6/84
35 & 36	7/76	35 & 36	12/6/84
41 & 42	4/1/83	41 & 42	12/6/84
89	4/1/83	89	4/1/83
90	4/1/83	90	12/6/84
173	6/80	173	12/6/84
174	6/80	174	6/80
177	6/80	177	12/6/84
178	6/80	178	6/80
179	6/80	179	12/6/84
180	6/80	180	6/80

Kenneth S. Hunt
Kenneth S. Hunt
Director of Flight Operations

Distribution: ZVS-827

Initiated By: AVN-200/AFO-200

THIS PAGE INTENTIONALLY LEFT BLANK

CHANGE

**DEPARTMENT OF TRANSPORTATION
FEDERAL AVIATION ADMINISTRATION**

8260.3B CHG 8

Army. TM 95-226
Navy. OPNAV Inst 3722.16C
Air Force. AFM 55-9
Coast Guard. CG 318

3/24/86

SUBJ: UNITED STATES STANDARD FOR TERMINAL INSTRUMENT PROCEDURES (TERPS)

PURPOSE. This change adds new criteria to TERPS to permit course reversal using non-collocated navigational aids and procedure turn criteria where the turn fix is other than the facility or final approach fix (FAF).

PAGE CONTROL CHART

Remove Pages	Dated	Insert Pages	Dated
vii	4/1/83	vii	4/1/83
viii	12/6/84	viii	3/24/86
xxi and xxii	12/6/84	xxi and xxii	3/24/86
15 and 16	4/1/83	15 and 16	3/24/86
		16-1	3/24/86
		16-2	3/24/86
17	11/15/83	17	3/24/86
18	4/1/83	18	3/24/86
19 and 20	4/1/83	19 and 20	3/24/86
		20-1	3/24/86
		20-2	3/24/86
21 and 22	4/1/83	21	3/24/86
		22	4/1/83

William T. Brennan
Acting Director of Flight Standards

Distribution: ZVS-827

Initiated By: AFO-200/AVN-200

THIS PAGE INTENTIONALLY LEFT BLANK

CHANGE

8260.3B CHG 9

ARMY TM 11-2557-26
NAVY . . OPNAV INST 3722.16B
USAF AFM 55-9
USCG UNNUMBERED

7/26/90

SUBJ: UNITED STATES STANDARD FOR TERMINAL INSTRUMENT PROCEDURES (TERPS)

1. **PURPOSE.** This change transmits Chapter 15, Area Navigation (RNAV), to the United States Standard for Terminal Instrument Procedures (TERPS), Order 8260.3B; Department of the Army Technical Manual, TM 11-2557-26; Department of the Navy, OPNAV INST 3722.16B; Department of the Air Force Manual, AFM 55-9; and the United States Coast Guard manual, unnumbered.

2. **SUMMARY OF CHANGES.** Chapter 15, Area Navigation (RNAV), is a major change and addition of criteria. Appendix 6 is revised to include additional terminology. The Table of Contents is revised to include chapter 15 with additional figures and tables.

3. **DISPOSITION OF TRANSMITTAL.** Retain this page after changed pages have been filed.

PAGE CONTROL CHART

REMOVE PAGES	DATED	INSERT PAGES	DATED
vii	4/1/83	vii thru xxix (and xxx)	7/26/90
viii	3/24/86		
ix thru xx	4/1/82		
xxi, xxii	3/24/86		
xxiii	4/1/83		
xxiv thru xxv (and xxvi)	12/6/84		
		15-1 thru 15-32	7/26/90
Appendix 6 1 thru 19 (and 20)	4/1/83	Appendix 6 1 thru 21 (and 22)	7/26/90

DC Beaudette
Daniel C. Beaudette
Director, Flight Standards Service

THIS PAGE INTENTIONALLY LEFT BLANK

CHANGE

U.S. DEPARTMENT OF TRANSPORTATION
FEDERAL AVIATION ADMINISTRATION

8260.3B CHG 10

ARMY TM 11-2557-26
NAVY .. OPNAV INST 3722.16B
USAF AFM 55-9
USCG UNNUMBERED

12/4/90

SUBJ: UNITED STATES STANDARD FOR TERMINAL INSTRUMENT PROCEDURES (TERPS)

1. PURPOSE. This change makes minor changes to table 9, chapter 3, Civil Straight-In Minimums, as a follow-up to Action Notice A8260.6. The change removes reference to middle marker (MM) in note 3 under nonprecision minimums; references operations specifications regarding MM under precision approach (line 14); and reduces "D" category runway visual range (RVR) in line 13, precision approach.

2. DISPOSITION OF TRANSMITTAL. Retain this page after changed page has been filed.

PAGE CONTROL CHART

REMOVE PAGES	DATED	INSERT PAGES	DATED
43-44	4/1/83	43	12/4/90
		44	4/1/83

William C. Witnycombe
William C. Witnycombe
Acting Director, Flight Standards Service

Distribution: ZVS-827

Initiated By: AVN-540/AFS-420

THIS PAGE INTENTIONALLY LEFT BLANK

CHANGE

U.S. DEPARTMENT OF TRANSPORTATION
FEDERAL AVIATION ADMINISTRATION

8260.3B CHG 11

ARMY TM 11-2557-26
NAVY .. OPNAV INST 3722.16B
USAF AFM 55-9
USCG UNNUMBERED

5/7/92

SUBJ: UNITED STATES STANDARD FOR TERMINAL INSTRUMENT PROCEDURES (TERPS)

1. **PURPOSE.** This change refines criteria in paragraph 323b for adjustments to minimums required for obstacle clearance necessary when utilizing a remote altimeter setting source (RASS). The method in which procedures specialists apply required adjustments is changed. The concepts of non-homogeneous weather and precipitous terrain are absorbed within the computational formula and further adjustments for those situations are not required. Figure 37B on page 41 was renumbered 37D to accommodate two new figures, 37B and 37C, page 38-2.

2. **DISPOSITION OF TRANSMITTAL.** Retain this page after changed page has been filed.

PAGE CONTROL CHART

REMOVE PAGES	DATED	INSERT PAGES	DATED
xxv-xxvi	7/26/90	xxv	
		xxvi	7/26/90
37	4/1/83	37	4/1/83
38	1/27/84	38	
		38-1	
		38-2	
41	12/6/84	41	
42	12/6/84	42	12/6/84

Thomas C. Accardi
Director, Flight Standards Service

Distribution: ZVS-827

Initiated By: AVN-540/AFS-420

THIS PAGE INTENTIONALLY LEFT BLANK

CHANGE

U.S. DEPARTMENT OF TRANSPORTATION
FEDERAL AVIATION ADMINISTRATION

8260.3B CHG 12

ARMY TM 11-2557-26
NAVY . . OPNAV INST 3722.16B
USAF AFM 55-9
USCG UNNUMBERED

5/21/92

SUBJ: UNITED STATES STANDARD FOR TERMINAL INSTRUMENT PROCEDURES (TERPS)

1. **PURPOSE.** This change provides a descent gradient table for high altitude jet penetrations using arcs of less than 15 miles (par 232a). Table 10 is changed to provide 1/4 mile credit for ODALS on a precision straight-in. Appendix 2 is changed to provide specific guidance to computed required procedural parameters for some military PAR systems.

2. **DISPOSITION OF TRANSMITTAL.** Retain this page after changed page has been filed.

PAGE CONTROL CHART

REMOVE PAGES	DATED	INSERT PAGES	DATED
11-12	12/6/84	11	5/21/92
		12	12/6/84
		12-1 (and 12-2)	12/6/84
43-44	12/4/90	43	12/4/90
	4/1/83	44	5/21/92
Appendix 2		Appendix 2	
11-12	4/1/83	11	4/1/83
		12	5/21/92

Thomas C. Accardi
Director, Flight Standards Service

Distribution:

ZVS-827

Initiated By:

AVN-540/AFS-420

THIS PAGE INTENTIONALLY LEFT BLANK

CHANGE

U.S. DEPARTMENT OF TRANSPORTATION
FEDERAL AVIATION ADMINISTRATION

8260.3B CHG 13

3/12/93

ARMY TM 95-226
NAVY OPNAV INST 3722.16C
USAF AFM 55-9
USCG UNNUMBERED

SUBJ: UNITED STATES STANDARD FOR TERMINAL INSTRUMENT PROCEDURES (TERPS)

1. **PURPOSE.** This change adds criteria to chapter 9, section 9, for triple simultaneous ILS procedures. Previously, this section covered only dual simultaneous ILS procedures. Existing figure 96 becomes figure 96A. Figure 96B is new. Existing figure 97 becomes figure 97A. In figure 97A, coverage of normal operating zones has been increased for clarity. Figure 97B is new. This change also includes corrections to change 12, published 5/21/92.

2. **DISPOSITION OF TRANSMITTAL.** Retain this page after changed page has been filed.

PAGE CONTROL CHART

REMOVE PAGES	DATED	INSERT PAGES	DATED
xv	7/26/90	xv	3/12/93
xvi	7/26/90	xvi	7/26/90
xxiii	7/26/90	xxiii	3/12/93
xxiv	7/26/90	xxiv	3/12/93
xxv	5/7/92	xxv	5/7/92
xxvi	7/26/90	xxvi	3/12/93
xxix (and xxx)	7/26/90	xxix (and xxx)	3/12/93
11	5/21/92	11	3/12/93
12	5/21/92	12	5/21/92
12-1 (and 12-2)	12/6/84	12-1 (and 12-2)	5/21/92
13	12/6/84	13	12/6/84
14	12/6/84	14	3/12/93
83	7/76	83	7/76
84-85 (and 86)	2/79	84-87 (and 88)	3/12/93
Appendix 2		Appendix 2	
11	4/1/83	11	4/1/83
12	5/21/92	12	4/1/83
		12-1 (and 12-2)	3/12/93

Thomas C. Accardi
Director, Flight Standards Service

THIS PAGE INTENTIONALLY LEFT BLANK

CHANGE

U.S. DEPARTMENT OF TRANSPORTATION
FEDERAL AVIATION ADMINISTRATION

8260.3B CHG 14

3/12/93

ARMY TM 95-226
NAVY OPNAV INST 3722.16C
USAF AFM 55-9
USCG CG 318

SUBJ: UNITED STATES STANDARD FOR TERMINAL INSTRUMENT PROCEDURES (TERPS)

1. **PURPOSE.** This change refines criteria in chapter 11, section 3, Takeoff and Landing Minimums, to more closely align with FAR 97.3(d.1) and applicable military regulations. Separate criteria have been developed for computing visibility for "copter-to-runway" approaches to minimum visibility values of one-half the corresponding Cat "A" fixed-wing value.

2. **DISPOSITION OF TRANSMITTAL.** Retain this page after changed page has been filed.

PAGE CONTROL CHART

REMOVE PAGES	DATED	INSERT PAGES	DATED
101	2/79	101	2/79
102	2/79	102	3/12/93
103	7/76	103	3/12/93
104	7/76	104	3/12/93

Thomas C. Accardi
Director, Flight Standards Service

Distribution: ZVS-827

Initiated By: AVN-540/
AFS-420

THIS PAGE INTENTIONALLY LEFT BLANK

CHANGE

U.S. DEPARTMENT OF TRANSPORTATION
FEDERAL AVIATION ADMINISTRATION

8260.3B CHG 15

ARMY TM 95-226
NAVY..... OPNAV INST 3722.16C
USAF..... AFM 55-9
USCG..... CG 318

9/10/93

SUBJ: UNITED STATES STANDARDS TERMINAL INSTRUMENT PROCEDURES (TERPS)

- PURPOSE.** This change deletes the TERPS requirement for middle markers for precision ILS approaches, thereby, removing the 50-foot penalty for all users of this instrument landing system.
- DISPOSITION OF TRANSMITTAL:** Retain this page after changed pages have been filed.

PAGE CONTROL CHART

REMOVE PAGES	DATED	INSERT PAGES	DATED
ix	7/26/90	ix	7/26/90
x	7/26/90	x	9/10/93
xiii	7/26/90	xiii	7/26/90
xiv	7/26/90	xiv	9/10/93
xxi	7/26/90	xxi	7/26/90
xxii	7/26/90	xxii	9/10/93
xxiii	3/12/93	xxiii	9/10/93
xxiv	3/12/93	xxiv	3/12/93
xxv	5/7/92	xxv	5/7/92
xxvi	3/12/93	xxvi	9/10/93
xxix (and xxx)	3/12/93	xxix	9/10/93
		xxx	9/10/93
29	4/1/83	29	9/10/93
30	4/1/83	30	4/1/83
43	12/4/90	43	9/10/93
44	5/21/92	44	5/21/92
75	2/79	75	9/10/93
76	2/79	76	2/79
77	4/1/83	77	9/10/93
78	4/1/83	78	9/10/93
85	3/12/93	85	3/12/93
86	3/12/93	86	9/10/93
87 (and 88)	3/12/93	86-1 (and 86-2)	9/10/93
9, Appendix 2	4/1/83	9, Appendix 2	9/10/93
10, Appendix 2	4/1/83	10, Appendix 2	4/1/83
13, Appendix 2	4/1/83	13, Appendix 2	4/1/83
14, Appendix 2	4/1/83	14, Appendix 2	9/10/93
15, Appendix 2	4/1/83	15, Appendix 2	4/1/83
16, Appendix 2	4/1/83	16, Appendix 2	9/10/93

Thomas C. Accardi
Director, Flight Standards Service

Distribution: ZVS-827

Initiated By: AFS-420

THIS PAGE INTENTIONALLY LEFT BLANK

CHANGE

**DEPARTMENT OF TRANSPORTATION
FEDERAL AVIATION ADMINISTRATION**

8260.3B CHG 16

ARMY..... TM 95-226
NAVY..... OPNAV INST 3722.16C
USAF..... AFM 55-9
USCG CG 318

2/18/94

SUBJ: UNITED STATES STANDARD FOR TERMINAL INSTRUMENT PROCEDURES (TERPS)

1. **PURPOSE.** This change further refines criteria in Order 8260.3B, chapter 3, section 2, paragraph 323b, Remote Altimeter Setting Source (RASS). This change also incorporates any editorial requirements occurring in chapter 9 from previous changes.
2. **DISTRIBUTION.** This change is distributed to all addressees on special distribution list ZVS-827.
3. **EXPLANATION OF CHANGES.** This change provides relief to the stringent requirements published in change 11 to this order while still meeting the basic tenants of safety in the RASS study on which this change is based. The concept of nonhomogeneous weather and terrain differentials is absorbed within the computational formula, and further adjustments for those situations are not required in the application of RASS adjustments. This change also updates the U.S. Navy addressees for Department of Defense distribution.
4. **DISPOSITION OF TRANSMITTAL.** Retain this page after changed pages have been filed.

PAGE CONTROL CHART

REMOVE PAGES	DATED	INSERT PAGES	DATED
v	12/6/84	v	2/18/94
vi	12/6/84	vi	12/6/84
37	4/1/83	37	4/1/83
38	5/7/92	38	2/18/94
38-1	5/7/92	38-1	2/18/94
38-2	5/7/92	38-2	2/18/94
75	9/10/93	75	2/18/94
76	2/79	76	2/79

William J. White
Deputy Director, Flight Standards Service

THIS PAGE INTENTIONALLY LEFT BLANK

CHANGE

**U. S. DEPARTMENT OF TRANSPORTATION
FEDERAL AVIATION ADMINISTRATION**

8260.3B CHG 17

2/13/98

ARMY TM 95-226
NAVY OPNAVINST 3722.16C
USAF AFJMAN 11-226
USCG CG 318

SUBJ: UNITED STATES STANDARD FOR TERMINAL INSTRUMENT PROCEDURES (TERPS)

1. **PURPOSE.** This change incorporates criteria contained in AVN Supplements to TERPS. It also corrects and updates criteria for evaluating the visual portion of an instrument approach, computing descent gradient, descent angle, and Visual Descent Point (VDP). Area navigation (RNAV) criteria are updated.
2. **DISTRIBUTION.** This change is distributed in Washington Headquarters to the division level of Flight Standards Service; Air Traffic Service; the Offices of Airport Safety and Standards; and Communications, Navigation, and Surveillance Systems; to the National Flight Procedures Office; the Regulatory Standards and Compliance Division at the Mike Monroney Aeronautical Center; to the regional Flight Standards divisions; and to special Military and Public Addressees.
3. **EFFECTIVE DATE.** April 20, 1998.
4. **EXPLANATION OF CHANGES.** This change incorporates all AVN Supplements to TERPS, provides a method for evaluating the visual portion of an instrument approach, and introduces criteria for determining final segment length based on descent angle. It revises ILS and PAR obstacle clearance calculations; adds criteria contained in FAA Order 8260.34, Glide Slope Threshold Crossing Height Requirements, to chapter 9; and updates chapter 15.
5. **DISPOSITION OF TRANSMITTAL.** After filing, this change transmittal should be retained.

PAGE CONTROL CHART

REMOVE PAGES	DATED	INSERT PAGES	DATED
vii (thru ix)	7/26/90		
x	9/10/93		
xi (thru xiii)	7/26/90		
xiv	9/10/93		
xv	3/12/93		
xvi (thru xx)	7/26/90	vii (thru xix)	2/13/98
1 (thru 4)	4/1/83		
5 (and 6)	11/15/83	1 (thru 5 and 6)	2/13/98
7	12/6/84		
8 (thru 10)	4/1/83		
11	3/12/93		
12 (thru 12-2)	5/21/92		
13	12/6/84		

Distribution: A-W(FS/AT/AS/ND)-2; AVN-100 (100 cys); AMA-200 (80 cys)
A-X(FS)-2; and Special Military and Public Addressees

Initiated By: AFS-420

PAGE CONTROL CHART (Continued)

REMOVE PAGES	DATED	INSERT PAGES	DATED
14	3/12/93		
15 (thru 21)	3/24/86		
22 (and 23)	4/1/83		
24	11/15/83		
25 (and 26)	4/1/83		
27	11/15/83		
28	2/79		
29	9/10/93		
30	4/1/83		
31	11/15/83		
32	4/1/83		
33 (and 34)	12/6/84		
34-1 (and 34-2)	11/15/83		
35 (and 36)	12/6/84	7 (thru 36-4)	2/13/98
39 (and 40)	4/1/83		
41	5/7/92		
42	12/6/84		
43	9/10/93	39 (thru 43)	2/13/98
44	5/21/92	44	5/21/92
45 (thru 47)	7/76	45 (thru 47)	2/13/98
48	7/76	48	7/76
49 (and 50)	7/76	49 (and 50)	2/13/98
55 (thru 57 and 58)	7/76	55 (thru 57 and 58)	2/13/98
59 (thru 63 and 64)	7/76	59 (thru 63 and 64)	2/13/98
67 (and 68)	4/1/83	67 (and 68)	2/13/98
77 (and 78)	9/10/93		
79 (thru 82)	2/79		
83	7/76		
84 (and 85)	3/12/93	77 (thru 85)	2/13/98
86	9/10/93	86	9/10/93
87 (thru 89)	4/1/83		
90	12/6/84	87 (thru 89 and 90)	2/13/98
15-1 (thru 15-3)	7/26/90	15-1 (thru 15-3)	2/13/98
15-4 (and 5)	7/26/90	15-4 (and 5)	7/26/90
15-6 (thru 15-32)	7/26/90	15-6 (thru 15-27)	2/13/98
APPENDIX 2		APPENDIX 2	
1 (and 2)	2/79		
3 (and 4)	4/1/83		
5	2/79		
6 (thru 8)	7/76		

PAGE CONTROL CHART (Continued)

REMOVE PAGES	DATED	INSERT PAGES	DATED
APPENDIX 2		APPENDIX 2	
9	9/10/93		
10 (thru 12)	4/1/83		
12-1 (and 12-2)	3/12/93		
13	4/1/83		
14	9/10/93		
15	4/1/83		
16	9/10/93		
17 (and 18)	4/1/83	1 (thru 6)	2/13/98

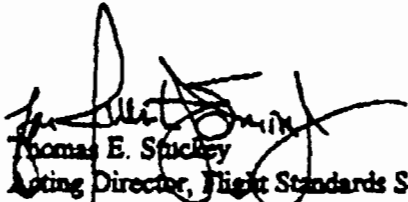
 Thomas E. Stuckey
 Acting Director, Flight Standards Service

THIS PAGE INTENTIONALLY LEFT BLANK

CHANGE

**U. S. DEPARTMENT OF TRANSPORTATION
FEDERAL AVIATION ADMINISTRATION**

8260.3B CHG 18

11/12/99

ARMY..... TM 95-226
NAVYOPNAVINST 3722.16C
USAF AFMAN 11-226(1)
USCG.....CG 318

SUBJ: UNITED STATES STANDARD FOR TERMINAL INSTRUMENT PROCEDURES (TERPS)

1. PURPOSE. This change transmits revised pages to Order 8260.3B, United States Standard for Terminal Instrument Procedures (TERPS).

2. DISTRIBUTION. This change is distributed in Washington Headquarters to the branch level in the Offices of Airport Safety and Standards; and Communications, Navigation, and Surveillance Systems; to Flight Standards, Air Traffic, and Airway Facilities Services; the National Flight Procedures Office and the Regulatory Standards Division at the Mike Monroney Aeronautical Center; to the branch level in the regional Flight Standards, Airway Facilities, and Air Traffic Divisions; special mailing list ZVS-827, and to special Military and Public Addressees.

3. EFFECTIVE DATE. January 20, 2000.

4. EXPLANATION OF CHANGES. Significant areas of new direction, guidance, and policy included in this change are as follows:

a. Paragraph 122a adds wording to ensure requirements in AC-150/5340-1, Marking of Paved Areas on Airports, and AC 150/5300-13, Airport Design, are met during instrument procedure design and review. The changes in these AC's will impact instrument procedures.

b. Paragraph 161 changes the approach procedure naming convention. Instrument landing system (ILS) procedures utilizing distance measuring equipment (DME) will no longer have DME in the procedure name. If DME is required to support ILS localizer minimums, the chart will be noted to indicate DME is required for localizer (LOC) final. The naming scheme for multiple approaches of the same type to the same runway is changed to use alphabetical suffixes. The procedure title "area navigation (RNAV)" indicates wide area augmentation system (WAAS), lateral navigation (LNAV)/ vertical navigation (VNAV), Flight Management System (FMS), or global positioning system (GPS) approach systems define the final segment. The title for these procedures is RNAV RWY.XX, etc.

c. Paragraph 234b changes the procedure turn protected airspace to allow it to vary according to the entry altitude. As the altitude increases, so does true airspeed. This change ensures the obstruction area will contain the PT maneuver regardless of initiation altitude.

d. Paragraph 251 increases the visual segment obstacle clearance surface (OCS) starting width associated with straight-in approaches from a total width of 400 feet (\pm 200 feet) to 800 feet (\pm 400 feet).

Distribution: A-W(AS/ND/FS/AT/AF)-3; AVN-100(150CYS); AMA-200 (80 CYS);
A-X(FS/AF/AT)-3; ZVS-827; Special Military and Public Addressees

Initiated By: AFS-420

e. Paragraph 252 publishes actual descent gradient to threshold crossing height (TCH) where straight-in minimums are prohibited because of excessive descent gradient. Publishing this value aids pilots in determining whether or not to attempt a straight-in landing and provides methodology for accommodating S/D fix altitudes above the final approach fix (FAF) to TCH descent.

f. Paragraph 253 adds requirement for the visual descent point (VDP) DME to be collocated with the facility providing final approach course guidance (U.S. Navy/U.S. Army/U.S. Air Force/U.S. Coast Guard NA). Wording is changed to clarify the requirement, but the meaning is not changed.

g. Paragraph 277b provides the "appropriate final required obstacle clearance (ROC)." Previous version required 250 feet of ROC regardless of facility type.

h. Paragraph 282c adds guidance to ensure marker beacons are used as fixes ONLY when associated with the facility providing course instructions.

i. Paragraph 334c adds the new guidance in AC 150/5300-13 that requires precision instrument runway markings for visibility minimums less than 3/4 statute mile, and requires touchdown zone lighting and runway centerline (TDZ/CL) for runway visual range (RVR) less than 2,400 feet.

j. Paragraph 1028 changes the wording to allow military operations with 100-foot category I height above touchdown (HAT) on precision approach radar (PAR) procedures.

5. INFORMATION CURRENCY.

a. Forward for consideration any deficiencies found, clarification needed, or suggested improvements regarding the contents of this order to:

DOT/FAA
Flight Procedure Standards Branch, AFS-420
P.O. Box 25082
Oklahoma City, OK 73125

b. Your assistance is welcome. FAA Form 1320-9, Directive Feedback Information, is included at the end of this change for your convenience. If an interpretation is needed immediately, you may call the originating office for guidance. However, you should use FAA Form 1320-9 as a follow-up to the verbal conversation.

c. Use the "Other Comments" block of this form to provide a complete explanation of why the suggested change is necessary.

6. DISPOSITION OF TRANSMITTAL. This change transmittal should be retained after changed pages are filed.

PAGE CONTROL CHART

REMOVE PAGES	DATED	INSERT PAGES	DATED
1 thru 6	2/13/98	1	2/13/98
		2 thru 5 (and 6)	11/12/99
13 and 14	2/13/98	12-1 thru 14	11/12/99
21 thru 26	2/13/98	21	2/13/98
		22 thru 26-1	11/12/99
31 thru 34	2/13/98	31	11/12/99
		32	2/13/98
		33	11/12/99
		34	2/13/98
37	4/1/83	37 thru 38-1	11/12/99
38 thru 38-2	2/18/94	38-2	2/18/94
39 thru 43	2/13/98	39 and 40	11/12/99
		41	2/13/98
		42	11/12/99
		43	2/13/98
44	5/21/92	44	5/21/92
44-1 (and 44-2)	4/1/83	44-1 (and 44-2)	4/1/83
89 (and 90)	2/13/98	89 (and 90)	11/12/99
15-11 and 12	2/13/98	15-11	11/12/99
		15-12	2/13/98

L. Nicholas Lacey
 Director, Flight Standards Service

THIS PAGE INTENTIONALLY LEFT BLANK

CHANGE

U.S. DEPARTMENT OF TRANSPORTATION
FEDERAL AVIATION ADMINISTRATION

8260.3B CHG 19

5/15/02

ARMY TM 95-226
NAVY OPNAV INST 3722.16C
USAF AFMAN 11-226(1)
USCG CG 318

**SUBJ: UNITED STATES STANDARD FOR TERMINAL INSTRUMENT PROCEDURES
(TERPS)**

1. PURPOSE. Change 19 divides Order 8260.3B into five volumes to aid in the efficiency of its use. The conversion from one volume in revision B to five volumes will be completed in four steps consisting of Changes 19 through 22. Change 22 will complete the conversion process, and the document will then be identified as revision "C." Cross referencing between volumes will be minimal. This change also transmits new and revised sections of this order (Volume 1).

2. DISTRIBUTION: This change is distributed in Washington Headquarters to the branch level in the Offices of Airport Safety and Standards; and Communications, Navigation, and Surveillance Systems; to Flight Standards, Air Traffic, and Airway Facilities Services; to the National Flight Procedures Office and the Regulatory Standards Division at the Mike Monroney Aeronautical Center; to the branch level in the regional Flight Standards, Airway Facilities, Air Traffic, and Airports Divisions; special mailing list ZVS-827, and to special Military and Public Addressees.

3. CANCELLATION. With the publication of Change 19, the following orders will be canceled: Orders 8260.36A, Civil Utilization of Microwave Landing System (MLS), dated January 19, 1996; 8260.39A, Close Parallel ILS/MLS Approaches, dated December 29, 1999; 8260.41, Obstacle Assessment Surface Evaluation for Independent Simultaneous Parallel Precision Operations, dated September 15, 1995; and 8260.47, Barometric Vertical Navigation (VNAV) Instrument Procedures Development, dated May 26, 1998.

4. EFFECTIVE DATE: June 14, 2002

5. EXPLANATION OF CHANGES. This is the first change to Order 8260.3B that contains volumes. The volume and paragraph numbers are identified on the inside bottom corner of the page and chapter and page numbers (example 1-1) are on the outside bottom corner of the page. Significant areas of new direction, guidance, and policy included in this change are as follows:

a. VOLUME 1, General Criteria (current TERPS order). Installs the current TERPS Manual as Volume 1 (insert all changes to this portion of the order before adding the other volumes). This volume contains information and criteria applicable to any instrument approach

procedure; e.g. administrative, en route, initial, intermediate, terminal fixes, holding, etc. Volume 1 will be completed with the implementation of Change 21.

(1) Chapter 1.

(a) Paragraph 6a. Adds the word "must" to convey that application of the criteria is mandatory.

(b) Paragraph 122a. Includes appendix number to the reference.

(c) Paragraph 161a. Clarifies directions for adding the suffix "DME" and noting the chart accordingly.

(d) Paragraph 173. Adds guidance for TERPS mathematics.

(e) Paragraph 174. Includes information for providing directive feedback.

(2) Chapter 2.

(a) Paragraphs 201, 202, and 203. Adds information and drawings concerning the TERPS concept of primary required obstacle clearance (ROC) and sloping and level obstacle clearance surfaces (OCS).

(b) Paragraph 234e(1). Provides guidance for establishing the minimum published holding altitude.

(c) Table 3 in Paragraph 242b(2). Changes minimum intermediate course lengths.

(d) Paragraph 251a(2)(b). Corrects information in this paragraph.

(e) Paragraph 253. Changes application of the visual descent point (VDP).

(f) Paragraph 274d. Brings up to date figures 17 and 18.

(g) Paragraph 275. Adds requirement for construction of turning or combination straight and turning missed approach areas. Adds note for clarification.

(h) Paragraph 287b(4)(b). Deletes example and figure 30 which is no longer required.

(i) Paragraph 287c(2). Changes figure 31-2 to reflect the current fix displacement calculations.

(3) Chapter 3.

(a) Paragraph 324. Adds current guidance concerning decision altitude (DA).

(b) Paragraph 325. Explains decision height (DH) as it relates to DA.

(c) Paragraph 350. Changes the title of table 9. TERPS Volume 3 now contains information for PRECISION minimums.

(4) Chapter 8, paragraph 813c(1). Updates reference to paragraph 523b(3) as all charts and explanations for solving secondary area obstacle problems have been deleted from appendix 2.

(5) Chapter 9. This change deletes chapter 9 with the exception of section 5 which becomes chapter 9, Localizer and Localizer Type Directional Aids (LDA). Paragraphs 951 through 957 become paragraphs 900 through 907. Volume 3 replaces most of chapter 9.

(6) Chapter 10. Volume 3 provides guidance that supersedes information in sections 2 and 3 of this chapter.

(7) Chapter 11, Paragraph 1105. Clarifies procedure identification of helicopter-only procedures.

(8) Chapter 12. This chapter becomes Volume 4 with four chapters; therefore, chapter 12 in this volume is reserved.

(9) Chapter 15.

(a) Paragraph 1513d(2). Updates reference to 1413d(1) as the ROC applied for this circling approach should be the same as the criteria applied to other chapters.

(b) Paragraph 1513f. Updates reference to chapter 2, section 8 as section 2 no longer contains criteria for the use of radio fixes.

(10) Chapter 17, paragraph 1731b. Updates reference to paragraph 1721 as all charts and explanations for solving secondary area obstacle problems have been deleted from appendix 2.

(11) Appendix 1. Adds title to appendix and an alphabetical listing of all the acronyms and abbreviations for old and new aviation terms used frequently throughout this order.

(12) Appendix 2. Deletes appendix 2 as this information is now in Volume 3, appendix 5.

(13) This change also provides guidance that supersedes chapter 3, section 1 of Order 8260.48, Area Navigation (RNAV) Approach Construction Criteria, dated April 8, 1999. The direction and guidance published in this change supersedes RELATED information in Order 8260.48. A major portion of Order 8260.48 remains in effect.

b. VOLUME 2, Nonprecision Approach Procedure (NPA) Construction, is reserved for Change 21. It will contain criteria central to nonprecision final approach segment construction. VHF omnidirectional range (VOR), VOR/distance measuring equipment (DME), nondirectional beacon (NDB), tactical air navigation (TACAN), airport surveillance radar (ASR), airborne radar approaches (ARA), localizer, simplified directional facility (SDF), localizer directional aid (LDA), direction finder (DF), area navigation (RNAV), and lateral navigation (LNAV) systems are supported. Criteria applicable to the initial missed approach climb unique to nonprecision approaches will be included in this volume.

c. VOLUME 3, Precision Approach (PA) and Barometric Vertical Navigation (Baro VNAV) Approach Procedure Construction. Replaces criteria originally located in chapter 9 and guidance from Orders 8260.36A, 8260.39A, 8260.41, and 8260.48, chapter 2, paragraphs 2.1, 2.3, 2.5-2.10, 2.12, and chapter 3, sections 1 and 2. This volume contains the final segment construction criteria for navigational systems that provide vertical guidance, instrument landing system (ILS), microwave landing system (MLS), transponder landing system (TLS), precision approach radar (PAR), Global Navigation Satellite landing system (GLS), wide area augmentation system (WAAS), local area augmentation system (LAAS), and Baro-VNAV. Obstruction clearance criteria applicable to simultaneous parallel, simultaneous converging, and Category II/III operations are included. Intermediate segment requirements and initial missed approach climb criteria unique to precision and Baro VNAV approaches are also contained in this volume.

d. VOLUME 4, Departure Procedure Construction. Replaces criteria originally located in chapter 12 of the TERPS order. This volume contains criteria departure obstruction supporting VOR, NDB, TACAN, ASR, localizer, and RNAV (in Change 21) navigation systems. Diverse departure, climb visually over the airport, and Air Traffic Control diverse vector areas are also covered. These criteria will be amended for use in the missed approach segment in Change 21.

e. VOLUME 5, Helicopter and Powered Lift Instrument Procedure Construction, is reserved for Change 21. It will contain all guidance for instrument procedure construction (en route, departure, approach) criteria.

6. PUBLICATION FORMAT. The double column, traditional paragraph numbering scheme of the TERPS document is changing to a single column, decimal number system more consistent with RTCA and the International Civil Aviation Organization (ICAO). The print is clear and illustrations are larger.

7. DISPOSITION OF TRANSMITTAL. The transmittal must be **RETAINED AND FILED IN THE BACK OF THIS MANUAL** until it is superseded by a revised order.

PAGE CONTROL CHART

REMOVE PAGES	DATED	INSERT PAGES	DATED
vii thru xix (and xx)	2/13/98	vii thru x	5/15/02
xxi	7/26/90		
xxii thru xxiii	9/10/93		
xxiv	3/12/93		
xxv	5/7/92		
xxvi	9/10/93		
xxvii thru xxviii	7/26/90		
xxix thru xxx	9/10/93		

PAGE CONTROL CHART

REMOVE PAGES	DATED	INSERT PAGES	DATED
		VOLUME 1	
		i thru xiv	5/15/02
1	2/13/98	1	5/15/02
2 thru 5	11/12/99	2	5/15/02
		3	11/12/99
		4 thru 6-1 (and 6-2)	5/15/02
7 thru 8	2/13/98	7-1 thru 7-4	5/15/02
		8	5/15/02
13 (and 14)	11/12/99	13 (and 14)	5/15/02
17 thru 18	2/13/98	17 thru 18	5/15/02
21	2/13/98	21	2/13/98
22 thru 26	11/12/99	22 thru 23	5/15/02
		24	11/12/99
		25 thru 26	5/15/02
27 thru 28	2/13/98	27	2/13/98
		28	5/15/02
33	11/12/99	33	5/15/02
34	2/13/98	34	2/13/98
35 thru 36	2/13/98	35 thru 36	5/15/02
38-1	11/12/99	38-1	5/15/02
38-2	2/18/94	38-2	2/18/94
41	2/13/98	41 thru 44	5/15/02
42	11/12/99		
43	2/13/98		
44	5/21/92		
69 thru 70	7/76		
71 thru 73 (and 74)	7/76	71 thru 73 (and 74)	5/15/02
75	2/18/94	9-1 (and 9-2)	5/15/02
76	2/79		
77 thru 85	2/13/98		
86 thru 86-1 (and 86-2)	9/10/93		
99 thru 100	4/1/83	99	5/15/02
		100	4/1/83
137 thru 138	4/1/83	137	4/1/83
		138	5/15/02
183 thru 184	6/80	183	5/15/02
		184	6/80
APPENDIX 1		APPENDIX 1	
1 thru 3	7/76	1 thru 6	5/15/02
APPENDIX 2			
1 thru 6	2/13/98 (Information from Appendix 2 can be found in Volume 3, Appendix 5)		

VOLUME 2 - RESERVED

PAGE CONTROL CHART

REMOVE PAGES	DATED	INSERT PAGES	DATED
		VOLUME 3	
		Table of Contents, (i thru vi)	5/15/02
		Chapter 1, 1-1 thru 1-8	5/15/02
		Chapter 2, 2-1 thru 2-15 (and 16)	5/15/02
		Chapter 3, 3-1 thru 3-18	5/15/02
		Chapter 4, 4-1 thru 4-13 (and 14)	5/15/02
		APPENDIX 1 - RESERVED	
		APPENDIX 2, 1 thru 5 (and 6)	5/15/02
		APPENDIX 3, 1 thru 8	5/15/02
		APPENDIX 4, 1 thru 9 (and 10)	5/15/02
		APPENDIX 5, 1 thru 5 (and 6)	5/15/02
		VOLUME 4	
		Table of Contents (i thru iii)	5/15/02
		Chapter 1, 1-1 thru 1-10	5/15/02
		Chapter 2, 2-1 thru 2-7 (and 8)	5/15/02
		Chapter 3, 3-1 thru 3-18	5/15/02
		Chapter 4, 4-1 thru 4-5 (and 6)	5/15/02
		VOLUME 5 Page - RESERVED	

James J. Ballough
 Director, Flight Standards Service

CHANGE

U.S. DEPARTMENT OF TRANSPORTATION
FEDERAL AVIATION ADMINISTRATION

8260.3B
CHG 20

National Policy

Effective Date:
12/07/07

SUBJ: United States Standard for Terminal Instrument Procedures (TERPS)

1. Purpose. Order 8260.3B, United States Standard for Terminal Instrument Procedures (TERPS), contains criteria that must be used to formulate, review, approve, and publish procedures for instrument approach and departure of aircraft to and from civil and military airports. These criteria are for application at any location over which the Federal Aviation Administration (FAA) or Department of Defense (DoD) exercises jurisdiction. *This change replaces criteria in Volume 1, chapter 3 with internationally harmonized minimums standards.*

2. Distribution. This change is distributed in Washington Headquarters to the branch level in the Offices of Aviation Research and Airport Safety and Standards, the Air Traffic Organization (Safety, En Route and Oceanic Services, Terminal Services, and Technical Operation Services), and Flight Standards Service; to the National Flight Procedures Office and the Regulatory Standards Division at the Mike Monroney Aeronautical Center; to the branch level in the regional Flight Standards and Airports Divisions; to the Technical Operations Service Areas and Air Traffic Service Areas; special mailing list ZVS-827, and to special military and public addressees.

3. Effective Date. December 21, 2007

4. Explanation of Changes. Significant areas of new direction, guidance, policy, and criteria as follows:

a. VOLUME 1, General Criteria. Chapter 3, Takeoff and Landing Minimums. The entire chapter has been revised to reflect the new standard for determining landing minima, the result of extensive coordination with European aviation authorities aimed at harmonizing landing minima affecting United States and European operators. The chapter has also been reformatted to improve clarity and ease of understanding. Highlights of the major changes in each section of the chapter are as follows:

(1) Section One, General Information.

(a) Added new groupings for approach lighting systems, aligned with international specifications;

Distribution: A-W(AR/AS/ND/FS/AT/AF)-3; AJW-32 (200 Cys); **Initiated By:** AFS-420
AMA-200 (12 Cys); A-X(FS/AF/AT/AS)-3; ZVS-827;
Special Military and Public Addressees

(b) Replaced the term Height Above Touchdown (HAT) with Height Above Threshold (HATh).

(c) Added a table establishing threshold crossing height (TCH) limits for allowing visibility credit for authorized lighting systems.

Note: Addition of this table rescinds table 2-6 of Order 8260.54A and table 2-2c of Order 8260.3. Volume 3.

(2) Section Two, Establishing Minimum Altitudes/Heights.

(a) Revised paragraphs on establishing Decision Altitudes/Heights and Minimum Descent Altitudes;

(b) Added a table prescribing the minimum height above threshold, based on glide-path angle.

(3) Section Three, Visibility Minimums.

(a) Developed completely new tables and methodology for establishing straight-in approach visibility minimums;

(b) Authorized minimums to 1800 runway visual range (RVR) to runways without touchdown zone or centerline lights; authorization is contingent upon the pilot's use of a flight director, coupled autopilot, or head-up display (HUD) system during the instrument approach;

(c) Revised requirements for authorizing "fly visual to airport" on approach charts;

(d) Expanded the HATh range within which minimums of 1800 RVR are authorized with operable touchdown zone and centerline lights;

(e) Expanded the methodology for establishing circling visibility minimums.

(4) Section Four, Alternate Minimums.

(a) Provided an expanded description of the process for establishing other-than-standard alternate minimums;

(b) Modified the alternate minimums table and added an example computation.

PAGE CONTROL CHART

Remove Pages	Dated	Insert Pages	Dated
VOLUME 1		VOLUME 1	
i thru ii	05/15/02	i thru ii	12/07/07
Vol 1, i thru xvi	05/15/02	Vol 1, i thru xvi	12/07/07
37 thru 44-2	11/12/99	3-1 thru 3-28	12/07/07

James J. Ballough
Director, Flight Standards Service

THIS PAGE INTENTIONALLY LEFT BLANK

CHANGE

**U.S. DEPARTMENT OF TRANSPORTATION
FEDERAL AVIATION ADMINISTRATION**

**8260.3B
CHG 21**

National Policy

Effective Date:
June 5, 2009

SUBJ: United States Standard for Terminal Instrument Procedures (TERPS)

1. Purpose. Order 8260.3B, United States Standard for Terminal Instrument Procedures (TERPS), contains criteria that must be used to formulate, review, approve, and publish procedures for instrument approach and departure of aircraft to and from civil and military airports. These criteria are for application at any location over which the Federal Aviation Administration (FAA) or Department of Defense (DoD) exercises jurisdiction.

Note: This change revises criteria in Volume 1, chapter 2 regarding final approach segment descent angles and circling maneuvering areas, updates table 3-5a in Volume 1, Chapter 3, replaces criteria in Volume 1, chapter 10 for Radar approaches and Minimum Vectoring Altitude Charts (MVAC), and revises Volume 3, chapter 3 criteria relating to the Glideslope Qualification Surface (GQS).

2. Distribution. This change is distributed in Washington Headquarters to the branch level in the Offices of Aviation Research and Airport Safety and Standards, the Air Traffic Organization (Safety, En Route and Oceanic Services, Terminal Services, and Technical Operation Services), and Flight Standards Service; to the National Flight Procedures Office and the Regulatory Standards Division at the Mike Monroney Aeronautical Center; to the branch level in the regional Flight Standards and Airports Divisions; to the Technical Operations Service Areas and Air Traffic Service Areas; special mailing list ZVS-827, and to special military and public addressees.

3. Effective Date. August 27, 2009.

4. Explanation of Changes. Significant areas of new direction, guidance, policy, and criteria as follows:

a. Volume 1, Chapter 2, General Criteria. The chapter has been revised to incorporate guidance from TERPS Instruction Letters (TILs) 99-014 and 00-012A which are rescinded. Additionally, it revises circling approach area criteria to resolve Government/Industry Aeronautical Charting Forum (ACF) issue #92-02-105. The criteria also includes the recommendations of the United States Instrument Flight Procedures Panel (US-IFPP) Change 21 Working Group to improve internal consistency and coherence.

(1) Section 5, Final Approach.

(a) Provides clarification of intent related to vertical descent angle (VDA) and removes redundant requirements related to final approach segment descent gradient.

(b) Provides updated guidance related to the range of acceptable VDAs and revises/clarifies criteria and figures for VDA calculations in straight-in and circling aligned approach cases (with and without stepdown fix) incorporating updated terminology and formulas.

(c) Updates guidance for establishing, calculating, and marking the Visual Descent Point (VDP), with consideration to procedures with multiple lines of NPA minima.

(2) Section 6, Circling Approach.

(a) Updates requirements related to the Circling Approach Area, revising the method of determining the size of the Obstacle Evaluation Area (OEA) to more closely align with ICAO methodology based ACF issue #92-02-105.

(b) Clarifies intent related to OEA evaluation when circling area restrictions are established based on ACF issue #92-02-105 and US-IFPP Change 21 Working Group recommendations.

(3) Section 7, Missed Approach. Updates terminology and clarifies design elements specified in the missed approach.

b. Volume 1, Chapter 3, Takeoff and Landing Minimums. The chapter has been revised to incorporate guidance from the March 14, 2008 memorandum subject: Equivalent Meter Runway Visual Range (RVR) and Visibility with RVR less than 2400 Authorized, which is rescinded. The revision replaces table 3-5a (including footnotes) in its entirety.

c. Volume 3, Chapter 10, Radar Procedures. The chapter has been revised in its entirety to incorporate guidance from the canceled Notice 8260.64, Radar Approaches and Minimum Vectoring Altitudes - Current Guidance and Criteria. It also includes guidance from the July 21, 2008 AFS-400 memorandum subject: Use of Automated Precipitous Terrain Algorithms for Minimum Vectoring Altitude (MVA) and Minimum Instrument Flight Rules (IFR) Altitude (MIA) Required Obstacle Clearance (ROC) Reductions and the September 10, 2008 AFS-400 memorandum subject: Interim Criteria for Radar Approaches and Minimum Vectoring Altitudes and Guidelines for Application of Glidepath Qualification Surface. These memorandums are rescinded. The criteria also includes the recommendations of the United States Instrument Flight Procedures Panel (US-IFPP) Change 21 Working Group to improve internal consistency and coherence.

d. Volume 3, Chapter 2, General Criteria. The chapter has been revised to incorporate guidance from the canceled Notice 8260.65, Guidelines for Application of Glidepath Qualification Surface (GQS) and the September 10, 2008 AFS-400 memorandum subject: Interim Criteria for Radar Approaches and Minimum Vectoring Altitudes and Guidelines for Application of Glidepath Qualification Surface which is rescinded. The criteria also includes the

recommendations of the United States Instrument Flight Procedures Panel (US-IFPP) Change 21 Working Group to improve internal consistency and coherence.

(1) Paragraph 2.9.1, Distance Measure Equipment (DME) incorporates guidance from the December 12, 2005 AFS-420 memorandum subject: Clarification of Issues Related to Criteria Coordination Committee Agenda Items related to issue 04-CCC-010.

(2) Paragraph 2.11 , Clear Areas and Obstacle Free Zones (OFZ) has been intentionally deleted in its entirety.

(3) Paragraph 2.12, Glidepath Qualification Surface (GQS) has been renumbered paragraph 2.11, and:

(a) All criteria and figures revised to clarify that the GQS area originates at the runway threshold, even when the sloping OCS is offset (i.e., low TCH case).

(b) Paragraph 2.11.1 text and formulas updated to accommodate vertically guided RNAV procedures (especially those with multiple lines of minima). It specifies that the assessment(s) of a GQS sloping surface be consistent with the vertical characteristics of each glidepath associated with the procedure/line of minima.

(c) Paragraph 2.11.1d(2) and figure 2-5g clarifies intent regarding permitted obstacles (i.e., excluded from consideration during GQS evaluation).

(4) Paragraph 2.13, ILS/MLS Critical Areas was deemed irrelevant to TERPS evaluations and intentionally deleted.

PAGE CONTROL CHART

Remove Pages	Dated	Insert Pages	Dated
Volume 1, Chapter 2		Volume 1, Chapter 2	
21	02/13/1998	21 thru 26-2	06/05/2009
22, 23	05/15/2002		
24	11/12/1999		
25, 26	05/15/2002		
26-1, 26-2	11/12/1999		
Volume 1, Chapter 3		Volume 1, Chapter 3	
3-21 thru 3-22	12/07/2007	3-21 thru 3-22	06/05/2009
Volume 1, Chapter 10		Volume 1, Chapter 10	
87 thru 98		10-1 thru 10-18	06/05/2009
Volume 3, Chapter 2		Volume 3, Chapter 2	
2-11 thru 2-16	05/15/2002	2-11 thru 2-18	06/05/2009

Original Signed By

John H. Allen
 Director, Flight Standards Service

CHANGE

**U.S. DEPARTMENT OF TRANSPORTATION
FEDERAL AVIATION ADMINISTRATION**

8260.3B
CHG 22

National Policy

Effective Date:
04/01/2011

SUBJ: United States Standard for Terminal Instrument Procedures (TERPS)

1. Purpose. Order 8260.3B, United States Standard for Terminal Instrument Procedures (TERPS), contains criteria that must be used to formulate, review, approve, and publish procedures for instrument approach and departure of aircraft to and from civil and military airports. These criteria are for application at any location over which the Federal Aviation Administration (FAA) or Department of Defense (DoD) exercises jurisdiction.

2. Audience. The primary audience for this notice is Department of Defense (DoD), Federal Aviation Administration (FAA), and designated third party designers of instrument procedures. The secondary audience includes other Air Traffic Organization (ATO) Service Area offices and Flight Standards headquarters and regional office Divisions/Branches.

3. Explanation of Changes. Significant areas of new direction, guidance, policy, and criteria as follows:

a. Volume 1, Chapter 10, Radar Approach Procedures and Vectoring Charts. This chapter has been revised to incorporate guidance from the Flight Systems Laboratory (AFS-450) safety analysis report, Technical Memorandum on Risk Associated with Minimum Vectoring Altitude/Minimum Instrument Altitude (MVA/MIA) Rounding Methods, dated October 6, 2010 with December 15, 2010 addendum. This report concluded that under certain conditions there is no appreciable increase in risk when the final result of altitude calculations is rounded to the nearest 100-ft increment. This change rescinds and replaces all previous draft guidance related to the referenced safety analysis report and has intentionally limited applicability to ATC radar Vectoring Charts. This guidance does not support altitude selection for any other TERPS application

4. Distribution. We will distribute this Order to Washington headquarters to the Group and Team level in the Air Traffic Organization (Safety, En Route and Oceanic Services, Terminal Services, System Operations Services, Technical Operations Services, and Mission Support Services), Offices of Airport Safety and Standards, and Offices of Air Traffic Oversight; to the branch level in Offices of Airport Safety and Standards; Flight Standards Service; to the Aeronautical Navigation Products Office (AeroNav Products, AJV-3), and to the Regulatory Standards Division (AMA-200), at the Mike Monroney Aeronautical Center; to the branch level in the regional Flight Standards and Airport Divisions; to all Flight Standards District Offices (FSDOs); to the Team level in the Air Traffic Organization Service Areas (En-Route and

Oceanic, Terminal, and Technical Operations); to special mailing list ZVN-826; and Special Military and Public Addressees.

PAGE CONTROL CHART

Remove Pages	Dated	Insert Pages	Dated
Volume 1, Chapter 10 10-17 and 10-18	06/05/2009	Volume 1, Chapter 10-17 thru 10-20	04/01/2011



John M. Allen
Director, Flight Standards Service

CHANGE

**U.S. DEPARTMENT OF TRANSPORTATION
FEDERAL AVIATION ADMINISTRATION**

8260.3B
CHG 23

National Policy

Effective Date:
08/17/2011

SUBJ: United States Standard for Terminal Instrument Procedures (TERPS)

1. Purpose. Order 8260.3B, United States Standard for Terminal Instrument Procedures (TERPS), contains the criteria used to formulate, review, approve, and publish procedures for instrument flight operations to and from civil and military airports. The purpose of this change is to incorporate Notice 8260.70 and the June 27, 2009 AFS-400 policy memorandum and to revise/reformat to clarify policies relating to the establishment of takeoff/landing minimums introduced by Change 20. This revision is not intended to modify or rescind any previous agreements relating to implementation.

2. Audience. The audience for this Order is the FAA organization responsible for instrument flight procedure (IFP) development. The secondary audience includes third party service providers, Air Traffic Organization (ATO) Service Area offices, Flight Standards headquarters and Regional office Divisions/Branches, and the applicable elements in the United States Army, Navy, Air Force, and Coast Guard (hereafter referred to as the U.S. Military or Military).

3. What this Order Cancels.

a. AFS-400 Memorandum dated June 27, 2009, “Establishing Straight-in and Circling Visibility Minimums; Clarification of Order 8260.3B, United States Standard for Terminal Instrument Procedures (TERPS), Volume 1, chapter 3, paragraph 3.3.2, 3.3.3, and Table 3-5a as clarified in AFS-400 Policy Memo dated March 14, 2008.”

b. Notice 8260.70, Change to the FAA Order 8260.3, Vol. 1, chapter 3, table 3-5a.

4. Explanation of Changes. Significant areas of new direction, guidance, policy, and criteria as follows:

a. Volume 1, Chapter 2, paragraph 210. This paragraph has been revised to delete reference to calculating nautical mile (NM) visibility in overseas locations.

b. Volume 1, Chapter 3, Section 3, Visibility Minimums. This section has been revised to address inconsistencies with other FAA guidance.

c. Volume 1, Chapter 3, Section 4, Alternate Minimums. This section has been revised to clarify policies and incorporate guidance from Order 8260.19, Flight Procedures and Airspace.

d. Volume 1, Chapter 3, Section 5, Takeoff Minimums. This section has been revised to add helicopter values to table 3-12.

5. Distribution. We will distribute this Order to Washington headquarters to the Group and Team level in the Air Traffic Organization (Safety, En Route and Oceanic Services, Terminal Services, System Operations Services, Technical Operations Services, and Mission Support Services), Offices of Airport Safety and Standards, and Offices of Air Traffic Oversight; to the branch level in Offices of Airport Safety and Standards; Flight Standards Service; to the Aeronautical Navigation Products Office (AeroNav Products, AJV-3), and to the Regulatory Standards Division (AMA-200), at the Mike Monroney Aeronautical Center; to the branch level in the regional Flight Standards and Airport Divisions; to all Flight Standards District Offices (FSDOs); to the Team level in the Air Traffic Organization Service Areas (En-Route and Oceanic, Terminal, and Technical Operations); special mailing list ZVN-826; and Special Military and Public Addressees.

PAGE CONTROL CHART

Remove Pages	Dated	Insert Pages	Dated
Table of Contents, Vol. 1 vii thru viii	12/07/07	Table of Contents, Vol. 1 vii thru viii	08/17/11
Volume 1, Chapter 2 7-3 through 7-4	05/12/02	Volume 1, Chapter 2 7-3 through 7-4	08/17/11
Volume 1, Chapter 3 3-13 through 3-28	12/07/07	Volume 1, Chapter 3 3-13 through 3-26	08/17/11

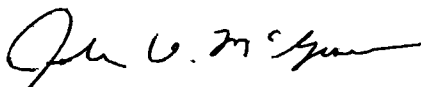
 John M. Allen
 Director, Flight Standards Service

CHANGE

**U.S. DEPARTMENT OF TRANSPORTATION
FEDERAL AVIATION ADMINISTRATION**

**8260.3B
CHG 24**

National Policy

Effective Date:
08/31/2011

SUBJ: United States Standard for Terminal Instrument Procedures (TERPS)

1. Purpose. Order 8260.3B, United States Standard for Terminal Instrument Procedures (TERPS), contains the criteria used to formulate, review, approve, and publish procedures for instrument flight operations to and from civil and military airports. The purpose of this change is to incorporate Notice 8260.68 and 8260.69 into the order.

2. Audience. The audience for this Order is the FAA organization responsible for instrument flight procedure (IFP) development. The secondary audience includes third party service providers, Air Traffic Organization (ATO) Service Area offices, Flight Standards headquarters and Regional office Divisions/Branches, and the applicable elements in the United States Army, Navy, Air Force, and Coast Guard (hereafter referred to as the U.S. Military or Military).

3. What this Order Cancels.

a. Notice 8260.68, Publication of Circling Minima on Vertically-Guided Instrument Approaches.

b. Notice 8260.69, Simultaneous Independent Parallel Instrument Approaches [SIPIA] – Widely Spaced Runways.

c. AFS-400 January 26, 2005 Memorandum, Standard for Decision Altitude (DA) Rounding Convention

4. Distribution. We will distribute this Order to Washington headquarters to the Group and Team level in the Air Traffic Organization (Safety, En Route and Oceanic Services, Terminal Services, System Operations Services, Technical Operations Services, and Mission Support Services), Offices of Airport Safety and Standards, and Offices of Air Traffic Oversight; to the branch level in Offices of Airport Safety and Standards; Flight Standards Service; to the Aeronautical Navigation Products Office (AeroNav Products, AJV-3), and to the Regulatory Standards Division (AMA-200), at the Mike Monroney Aeronautical Center; to the branch level in the regional Flight Standards and Airport Divisions; to all Flight Standards District Offices (FSDOs); to the Team level in the Air Traffic Organization Service Areas (En-Route and Oceanic, Terminal, and Technical Operations); special mailing list ZVN-826; and Special Military and Public Addressees.

PAGE CONTROL CHART

Remove Pages	Dated	Insert Pages	Dated
Table of Contents vii thru x	05/15/02	Table of Contents vii thru x	08/31/11
Volume 1, Chapter 3 Section Two 3-7 thru 3-13	12/07/07	Volume 1, Chapter 3 Section Two 3-7 thru 3-13	08/31/11
Volume 1, Chapter 3 Section Three 3-14	08/17/11	Volume 1, Chapter 3 Section Three 3-14	08/31/11
Volume 3, Appendix 2 1 thru 6	05/15/02	Volume 3, Appendix 2 A2-1 thru A2-4	08/31/11

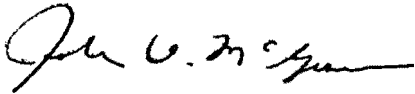

John M. Allen
Director, Flight Standards Service

CHANGE

**U.S. DEPARTMENT OF TRANSPORTATION
FEDERAL AVIATION ADMINISTRATION**

8260.3B
CHG 25

National Policy

Effective Date:
03/09/2012

SUBJ: United States Standard for Terminal Instrument Procedures (TERPS)

1. Purpose. Order 8260.3B, United States Standard for Terminal Instrument Procedures (TERPS), contains the criteria used to formulate, review, approve, and publish procedures for instrument flight operations to and from civil and military airports.

2. Who this change affects. The audience for this Order is the FAA organization responsible for instrument flight procedure (IFP) development. The secondary audience includes third party service providers, Air Traffic Organization (ATO) Service Area offices, Flight Standards headquarters and Regional office Divisions/Branches, and the applicable elements in the United States Army, Navy, Air Force, and Coast Guard (hereafter referred to as the U.S. Military or Military).

3. Where You Can Find This Order. You can find this order on the Federal Aviation Administration's (FAA) Web site at http://www.faa.gov/regulations_policies/orders_notices.

4. Explanation of changes.

a. Volume 3, Appendix 2. Updated paragraphs 1 and 2 for consistency with revisions to Air Traffic Directives based on study DOT-FAA-AFS-450-73, Comparative Evaluation of Lateral Flight Technical Error for Instrument Landing System and Localizer Only Approaches, which allows for the conditional use of localizer approach during a temporary glideslope outage.

5. Distribution. We will distribute this Order to Washington headquarters to the Group and Team level in the Air Traffic Organization (Safety, En Route and Oceanic Services, Terminal Services, System Operations Services, Technical Operations Services, and Mission Support Services), Offices of Airport Safety and Standards, and Offices of Air Traffic Oversight; to the branch level in Offices of Airport Safety and Standards; Flight Standards Service; to the Aeronautical Navigation Products Office (AeroNav Products, AJV-3), and to the Regulatory Standards Division (AMA-200), at the Mike Monroney Aeronautical Center; to the branch level in the regional Flight Standards and Airport Divisions; to all Flight Standards District Offices (FSDOs); to the Team level in the Air Traffic Organization Service Areas (En-Route and Oceanic, Terminal, and Technical Operations); special mailing list ZVN-826; and Special Military and Public Addressees.

PAGE CONTROL CHART

Remove Pages	Dated	Insert Pages	Dated
Volume 3, Appendix 2 A2-1 thru A2-2	08/31/11	Volume 3, Appendix 2 A2-1 thru A2-2	03/09/12

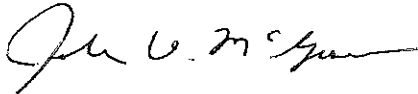

John M. Allen
Director, Flight Standards Service

Directive Feedback Information

Please submit any written comments or recommendation for improving this directive, or suggest new items or subjects to be added to it. Also, if you find an error, please tell us about it.

Subject: Order 8260.3B, United States Standard for Terminal Instrument Procedures

To: Directive Management Officer, _____

(Please check all appropriate line items)

- An error (procedural or typographical) has been noted in paragraph _____ on page _____ .
- Recommend paragraph _____ on page _____ be changed as follows:
(attached separate sheet if necessary)

- In a future change to this order, please include coverage on the following subject
(briefly describe what you want added):

Other comments:

I would like to discuss the above. Please contact me.

Submitted by: _____ Date: _____

Telephone Number: _____ Routing Symbol: _____